

High Speed Detection [≥40 mph (64 km/hr)]

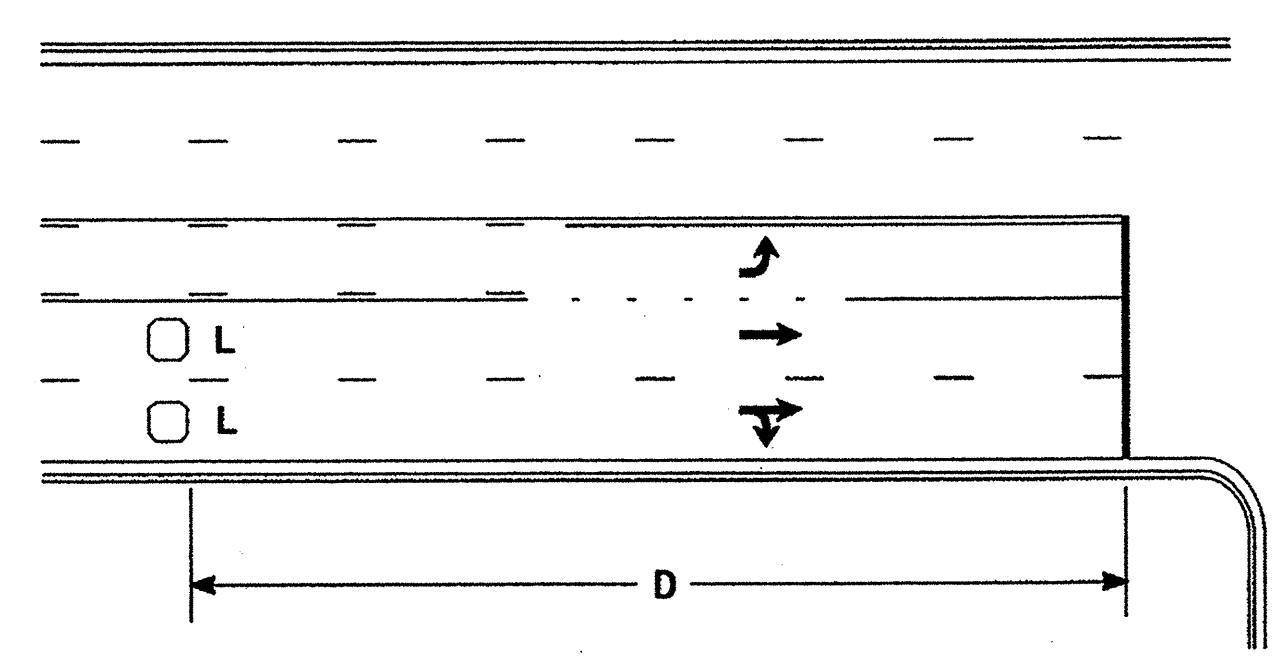

Speed Limit mph (km/hr)	D ft (m)
40 (64)	250 (75)
45 (72)	300 (90)
50 (80)	355 (110)
55 (88)	420 (130)

L = 6ft X 6ft (1.8m X 1.8m)
Wired in series for TS1
Controllers
Wired separately for TS2,
170, and 2070L Controllers

Volume Density Operation

OR

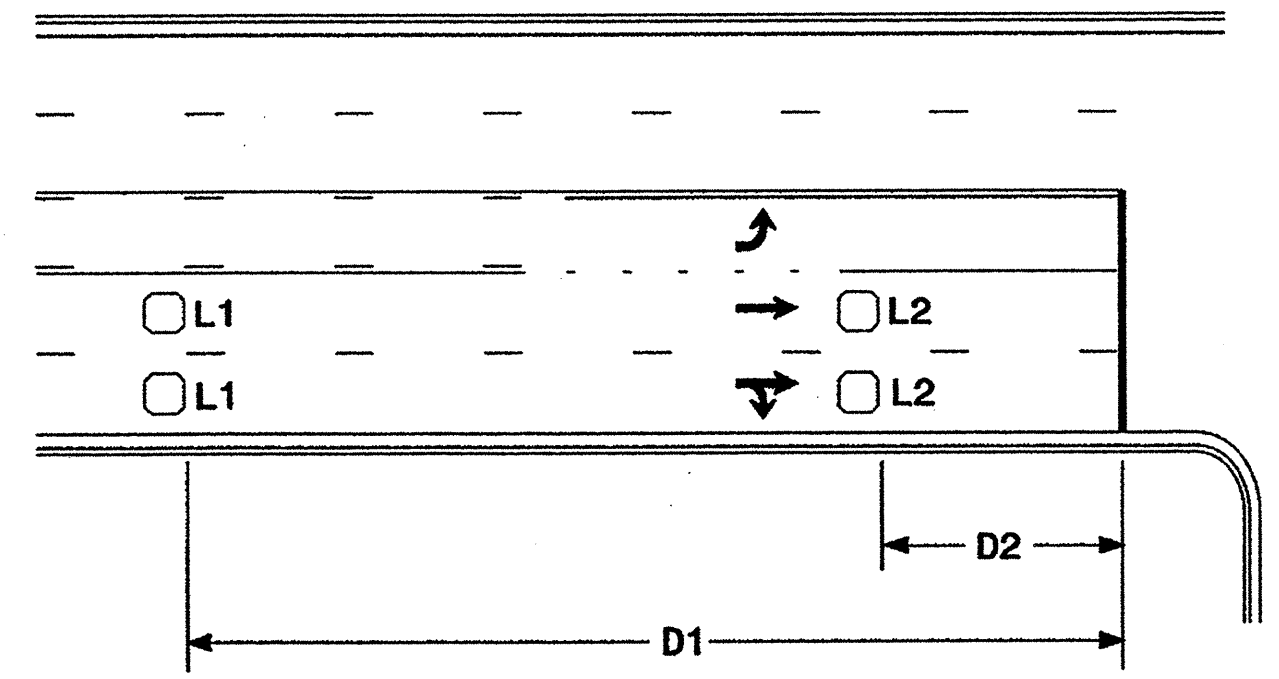

Speed Limit mph (km/hr)	D1 ft (m)	D2 ft (m)
40 (64)	250 (75)	80 (25)
45 (72)	300 (90)	90 (27)
50 (80)	355 (110)	100 (30)
55 (88)	420 (130)	110 (35)

L1 = 6ft X 6ft
(1.8m X 1.8m)
Wired in series
L2 = 6ft X 6ft
(1.8m X 1.8m)
Wired in series

"Stretch" Operation

Low Speed Detection [≤35 mph (56 km/hr)]

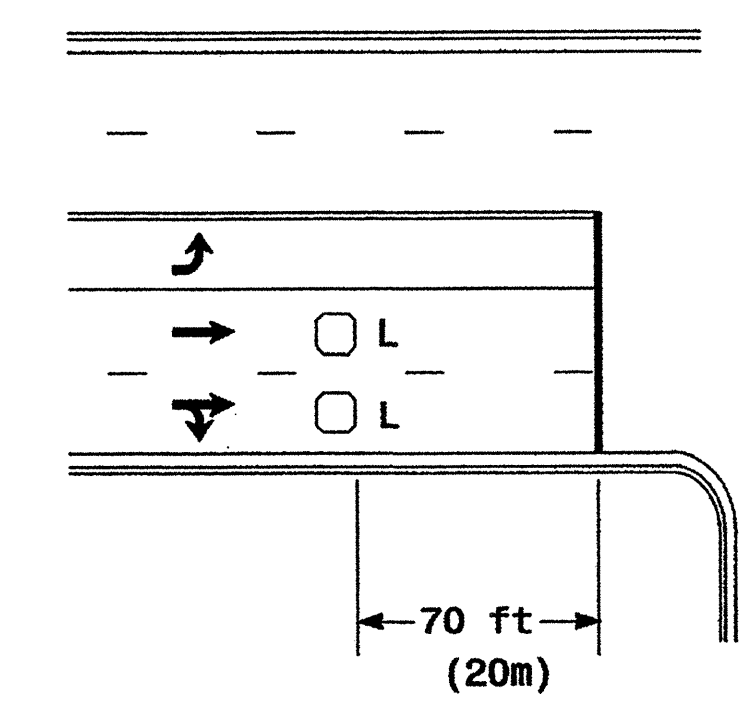

L = 6ft X 6ft (1.8m X 1.8m)
Wired in series

OR

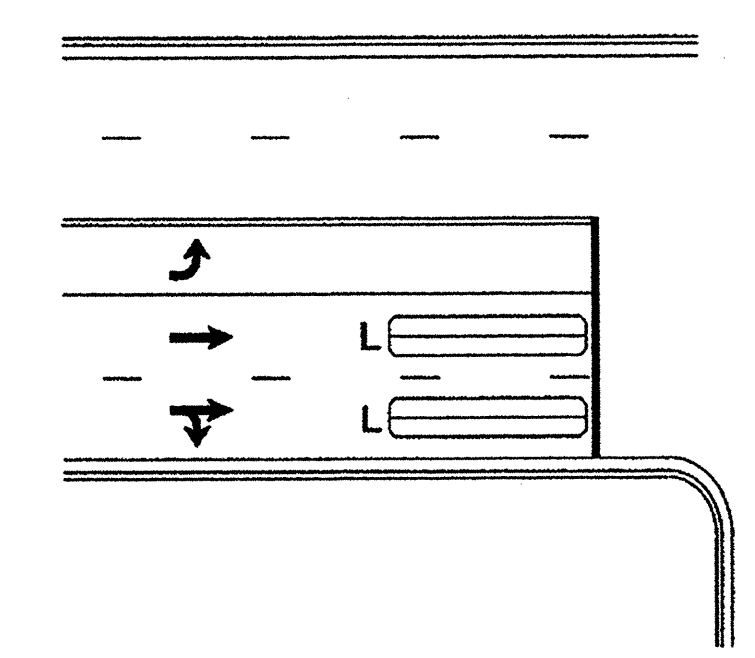

L = 6ft X 40ft (1.8m X 12.0m)
Quadrupole loop, wired separately

Left Turn Lane Detection

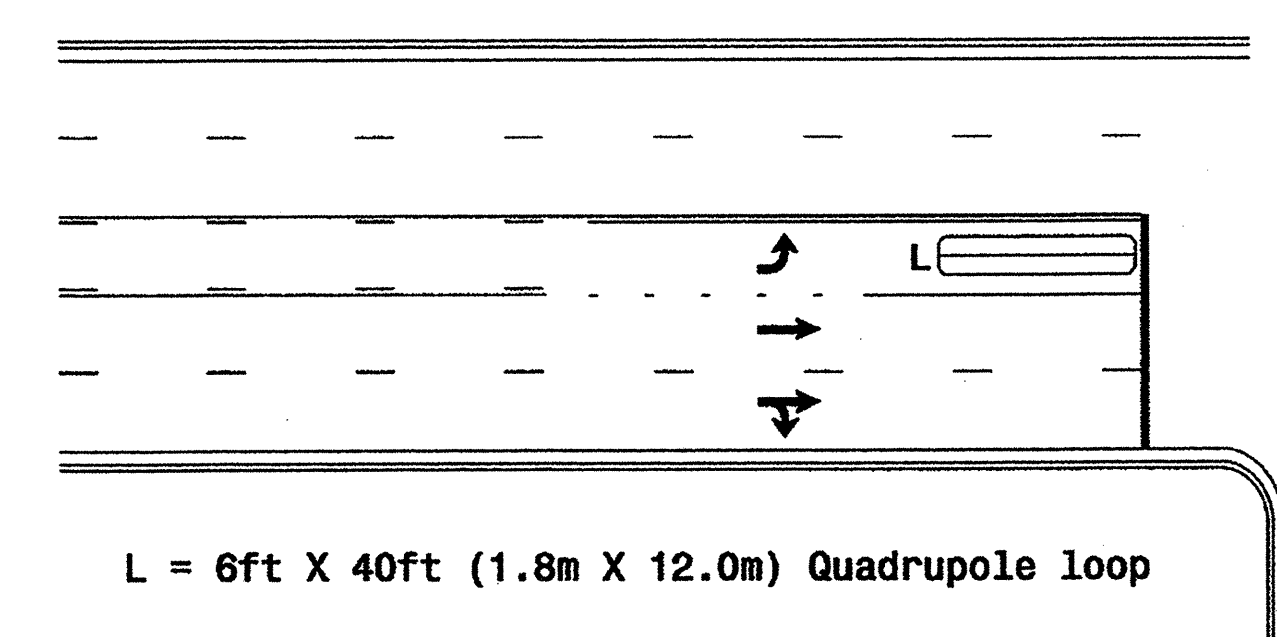

L = 6ft X 40ft (1.8m X 12.0m) Quadrupole loop

Presence Loop Detection

OR

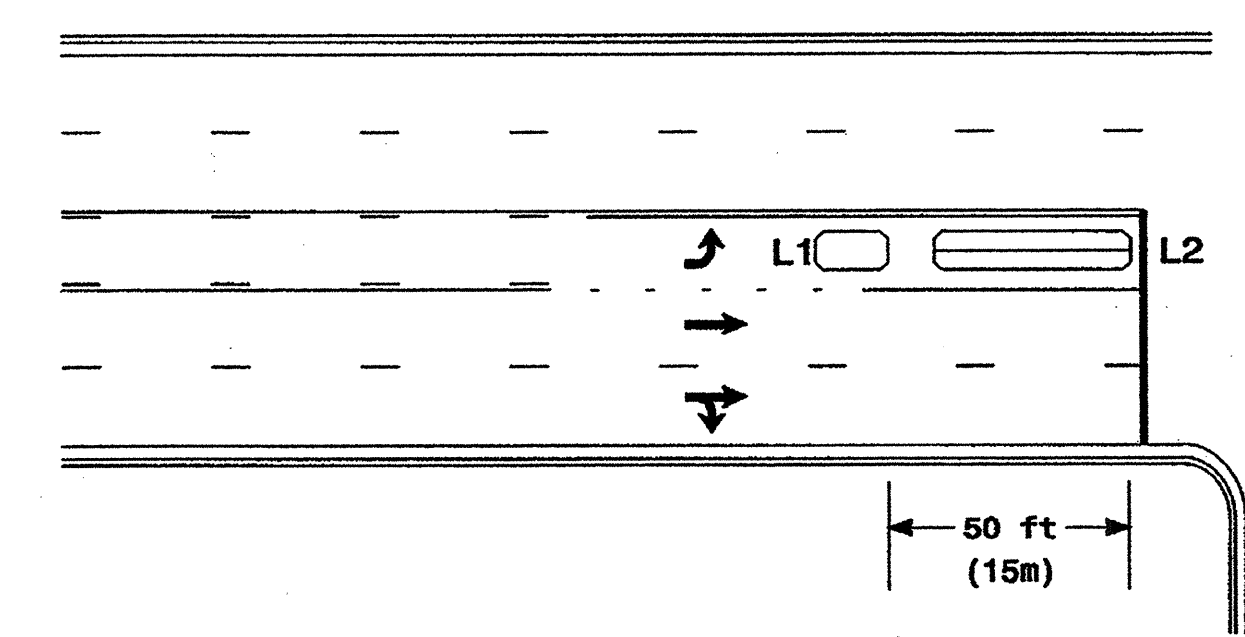

L1 = 6ft X 15ft (1.8m X 4.6m) Queue detector
L2 = 6ft X 40ft (1.8m X 12.0m) Quadrupole loop

Queue Loop Detection

Right Turn Lane Detection

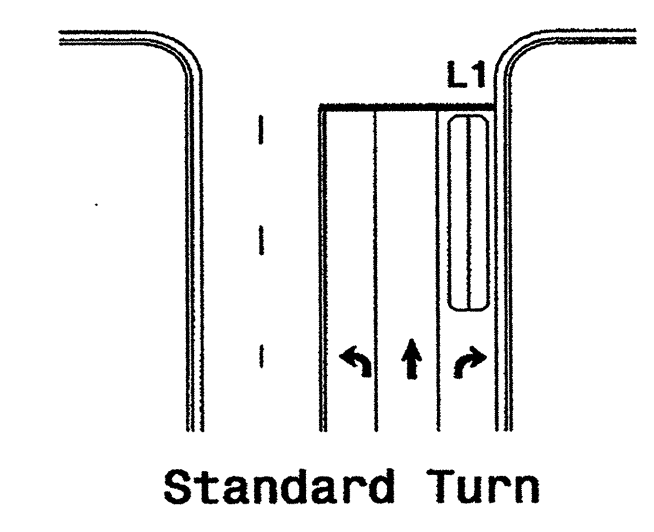

Standard Turn

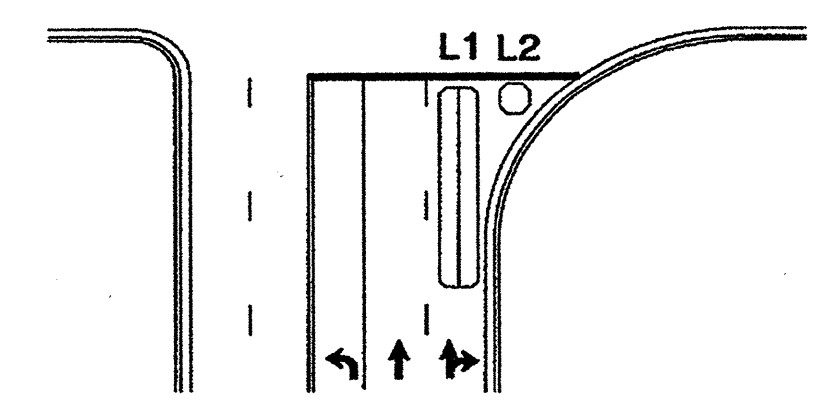

Wide Radius Turn

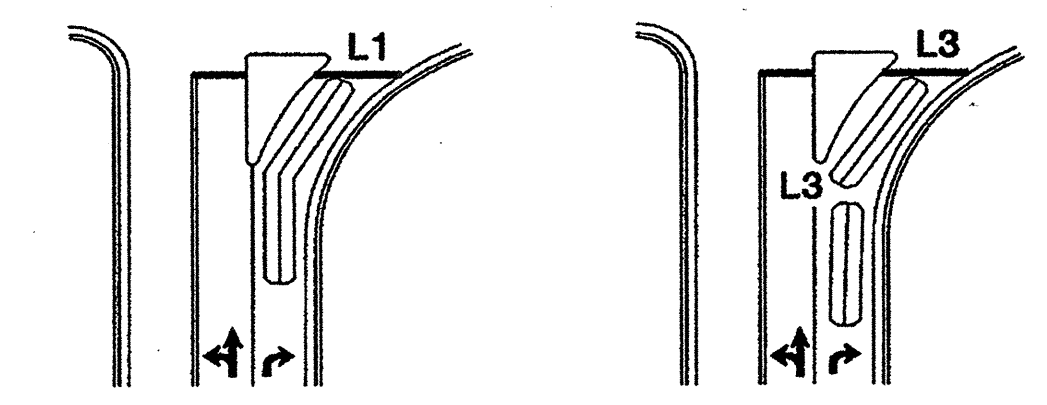

Channelized Turn

L1 = 6ft X 40ft (1.8m X 12.0m) Quadrupole loop
L2 = 6ft X 6ft (1.8m X 1.8m) [Minimum] Presence Loop
Wired separately
L3 = 6ft X 20ft (1.8m X 6.0m) Quadrupole loop
Wired in series

Side Street Detection

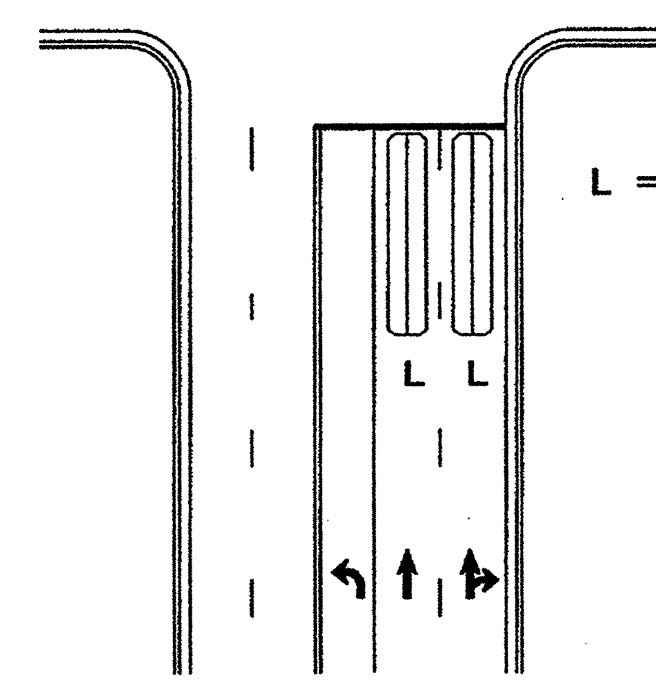

L = 6ft X 40ft (1.8m X 12.0m)
Quadrupole loop
Wired to separate
detectors/channels

Presence Loop Placement at Stop Lines

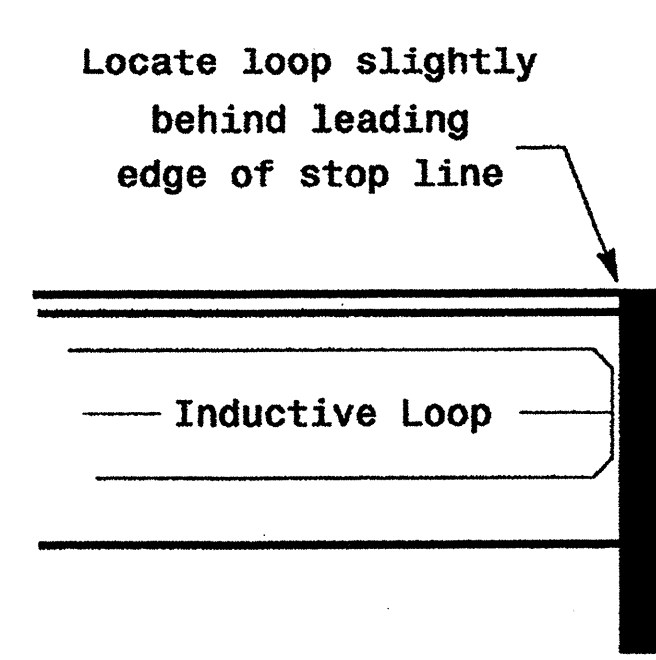

Locate loop slightly
behind leading
edge of stop line

Inductive Loop

Note:
Loop may be located in advance
of stop line when stop line is
greater than 15' (4.5m) from edge
of intersecting roadway; or, when
loop detects a permissive or
protected/permissive left turn.

Recommended Number of Turns

Single 6' X 6' (1.8m X 1.8m)
loop (wired separately):

Length of Lead-in ft (m)	Number of Turns
< 250 (75)	3
250-375 (75-115)	4
375-525 (115-160)	5
> 525 (160)	6

Quadrupole loops: Use 2-4-2 turns
6' X 15' (1.8m X 4.6m) Loops:
Lead-in < 150' (45 m), use 2 turns
Lead-in > 150' (45 m), use 3 turns

	Typical Loop Locations		
	PLAN DATE: June 2006 PREPARED BY: P L Alexander	REVIEWED BY:	
REVISIONS:		INIT. DATE	SIGNATURE DATE
REVISIONS:		INIT. DATE	SIGNATURE DATE