

PLAN - McDOWELL STREET TUNNEL

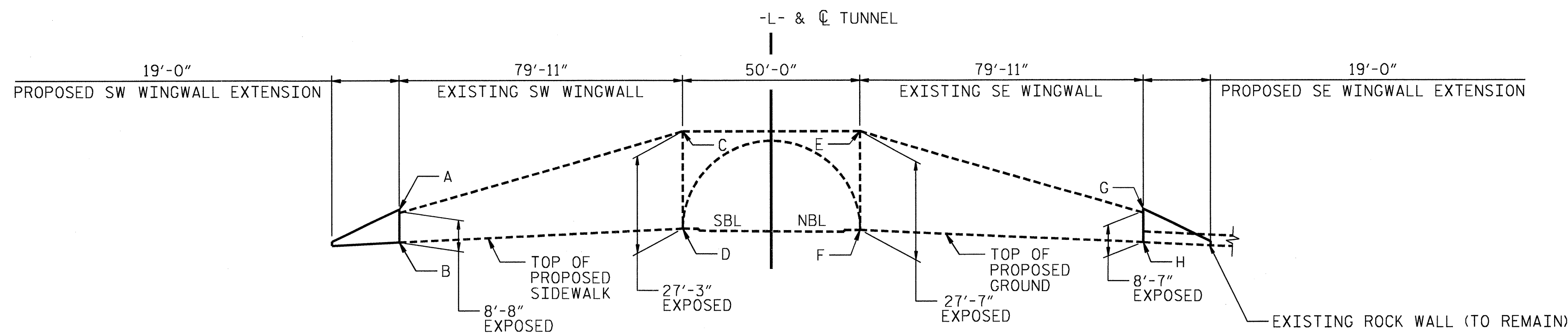

UNFOLDED SOUTH ELEVATION VIEW

(EXISTING END WALLS, PROPOSED COPING, RAILING, LIGHTING & VENEER NOT SHOWN)

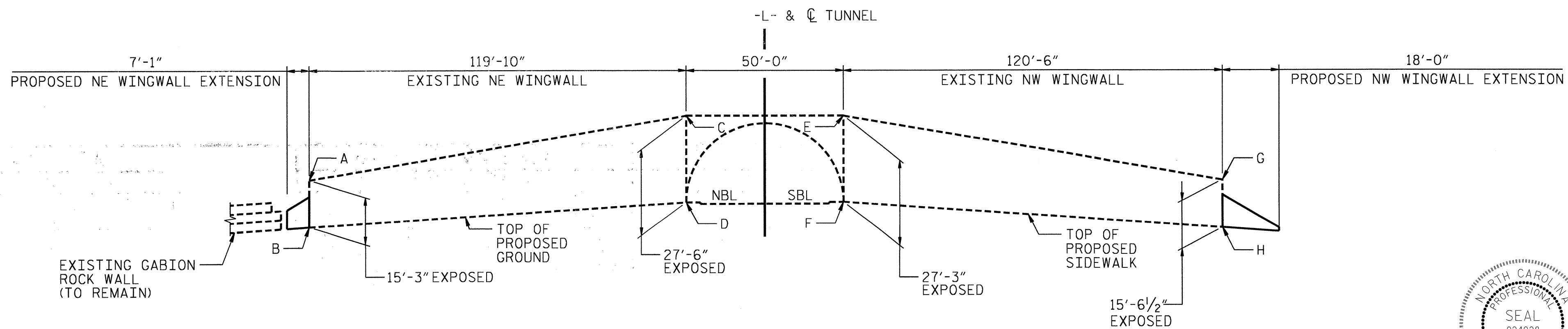

UNFOLDED NORTH ELEVATION VIEW

(EXISTING END WALLS, PROPOSED COPING, RAILING, LIGHTING & VENEER NOT SHOWN)

* EXISTING WINGWALL ELEVATIONS		
EL.	SOUTH	NORTH
A	2154.22	2149.88
B	2145.56	2134.58
C	2176.51	2170.06
D	2149.26	2142.56
E	2176.48	2169.98
F	2148.90	2142.73
G	2153.97	2149.69
H	2145.39	2134.15

* FOR PROPOSED WINGWALL EXTENSION ELEVATIONS, SEE PROPOSED WINGWALL SHEETS.

PROJECT NO. U-4014
 BUNCOMBE COUNTY
 STATION: _____



STATE OF NORTH CAROLINA
 DEPARTMENT OF TRANSPORTATION
 RALEIGH
 GENERAL DRAWING
 TUNNEL PLAN AND
 ENTRANCE ELEVATIONS

REVISIONS						SHEET NO. S-1
NO.	BY:	DATE:	NO.	BY:	DATE:	
1			3			TOTAL SHEETS 30
2			4			

DRAWN BY: M.J. SELLS DATE: 05/11
 CHECKED BY: J.B. TAYLOR DATE: 05/11

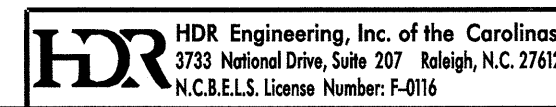

PLOT DRIVER: NCDDOT\pdf_mono_eng_50.plt
 USER: msells
 FILE: North Carolina Dept. of Transportation\NCDDOT\U-4014_McDowell_Street\1300_CAD\U-4014_Structures\U4014_S01_CD_01.dgn
 PENTABLE: MDT_pen.tbl
 DATE: 9/7/2012
 TIME: 1:40:43 PM

DESIGN AND CONSTRUCTION SPECIFICATIONS

STANDARD SPECIFICATIONS FOR ROADS AND STRUCTURES (2012)

NCDOT ROADWAY STANDARD DRAWINGS (2012)

AASHTO LRFD BRIDGE DESIGN SPECIFICATIONS (2010)

ACI 530-08 BUILDING CODE REQUIREMENTS AND SPECIFICATION FOR MASONRY STRUCTURES

GENERAL

EXISTING TUNNEL AND REPAIR INFORMATION INDICATED ON THE PLANS IS FROM THE BEST INFORMATION AVAILABLE. SINCE THIS INFORMATION IS SHOWN FOR THE CONVENIENCE OF THE CONTRACTOR, THE CONTRACTOR SHALL HAVE NO CLAIM WHATSOEVER AGAINST THE DEPARTMENT OF TRANSPORTATION FOR ANY DELAYS OR ADDITIONAL COST INCURRED BASED ON DIFFERENCES BETWEEN THE EXISTING TUNNEL AND REPAIR INFORMATION SHOWN ON THE PLANS AND THE ACTUAL SITE CONDITIONS AT THE PROJECT SITE.

THE CONTRACTOR SHALL VERIFY THE INFORMATION SHOWN ON THE PLANS AND NOTIFY THE ENGINEER IF ACTUAL DIMENSIONS AND CONDITIONS DIFFER.

THE LOCATION AND EXTENT OF REPAIRS SHOWN ON THE PLANS ARE GENERAL IN NATURE. THE ENGINEER WILL DETERMINE THE EXACT EXTENT OF REPAIRS BASED ON AN EVALUATION OF THE PROJECT SITE.

CONSTRUCTION METHODS, PROCEDURES AND SEQUENCES ARE THE CONTRACTOR'S RESPONSIBILITY AND THE CONTRACTOR SHALL TAKE ALL NECESSARY MEANS TO MAINTAIN AND PROTECT THE STRUCTURAL INTEGRITY AT ALL STAGES.

THE MANUFACTURER'S CERTIFIED DRAWINGS AND SPECIFICATION FOR EQUIPMENT ANCHORAGE AND DETAILS SHALL BE SUBMITTED FOR APPROVAL.

FOR FALSEWORK AND FORMWORK, SEE SPECIAL PROVISIONS.

FOR ADHESIVELY ANCHORED DOWELS AND ANCHOR BOLTS, SEE STANDARD SPECIFICATIONS.

REPAIR AREAS INACCESSIBLE BY POWER TOOLS SHALL BE PREPARED WITH HAND TOOLS.

CONCRETE REPAIRS

THE REPAIR PLANS INDICATE FOUR TYPES OF CONCRETE REPAIR AREAS. TYPES 1, 2, AND 3 IDENTIFY APPROXIMATE LOCATIONS WHERE THE CONCRETE SURFACE IS TO BE PREPARED FOR APPLICATION OF SHOTCRETE REPAIRS IN ACCORD WITH THE SPECIAL PROVISIONS. TYPE 1 INDICATES DELAMINATION, TYPE 2 INDICATES SPALLING, TYPE 3 INDICATES SPALLING WITH EXPOSED REINFORCEMENT OR CONDUIT, TYPE 4 INDICATES AREAS WITHIN THE TUNNEL WHERE THE EXISTING GUNNITE COATING IS DELAMINATING OR IN A WEAKENED STATE AS DETERMINED USING HAMMER SOUNDINGS. ALL NON-SOUND GUNNITE COATING WITHIN THE TUNNEL SHALL BE REMOVED. SEE ADDITIONAL "TUNNEL SURFACE TREATMENT" NOTES BELOW.

FOR SHOTCRETE REPAIR, SEE SPECIAL PROVISIONS.

FOR EPOXY RESIN INJECTIONS, SEE SPECIAL PROVISIONS.

THE CONTRACTOR SHALL PROTECT TRAFFIC (VEHICULAR AND PEDESTRIAN) FROM FALLING DEBRIS, SHOTCRETE OVERSPRAY AND TUNNEL COATING MATERIAL.

EXISTING FENCE POSTS SHALL BE CUT OFF AT THE CONCRETE SURFACE AND BACKFILLED WITH MORTAR OR CONCRETE.

TUNNEL SURFACE TREATMENT

AREAS WHERE EXISTING GUNNITE COATING HAVE BEEN REMOVED (TYPE 4 REPAIR AREAS) SHALL NOT RECEIVE NEW GUNNITE OR SHOTCRETE COATING.

FOLLOWING ALL CONCRETE REPAIR WORK AND PRIOR TO INSTALLATION OF THE LIGHTING SYSTEM, THE INTERIOR SURFACE OF THE TUNNEL SHALL BE CLEANED AND COATED WITH GRAFFITI-RESISTANT COATING. SEE SPECIAL PROVISIONS.

ANCHORED VENEER

FOR ANCHORED VENEER, SEE SPECIAL PROVISIONS.

SAFETY FENCE

FOR VINYL COATED CHAIN LINK FENCE, SEE SPECIAL PROVISIONS.

REFER TO RDWY, STD. DWG. NO. 866.01 FOR ALL CHAIN LINK FENCE PARTS, SPACING AND DIMENSIONS.

SAFETY FENCE SHALL BE A MINIMUM OF 4'-0" TALL.

FENCE POSTS SHALL BE INSTALLED VERTICALLY.

FOR FENCE CONNECTION DETAILS, REFER TO SHEET 2.

REFER TO PLAN SHEETS S-1 FOR LIMITS OF FENCE INSTALLATION.

REFER TO PLAN SHEETS S-19, S-21, S-22 AND S-23 FOR TYPICAL SECTIONS OF FENCE INSTALLATION.

PROPOSED VINYL COATED CHAIN LINK FENCE

LOCATION	FABRIC LENGTH	LINE POSTS	TERMINAL POSTS	REMARKS
SW WING WALL EXTENSION	21'-0"	2	2	SEE SHEET 2 FOR FENCE CONNECTION DETAILS
SW WING WALL	83'-0"	7	0	
SE WING WALL EXTENSION	21'-0"	2	2	
SE WING WALL	83'-0"	7	0	
NW WING WALL EXTENSION	21'-0"	2	2	
NW WING WALL	122'-3"	10	1	
NE WING WALL EXTENSION	8'-4"	0	2	
NE WING WALL	121'-6"	10	1	
SOUTH PORTAL HEADWALL	51'-0"	4	2	
NORTH PORTAL HEADWALL	51'-0"	4	2	
TOTAL	583'-1"	48	14	

COPING AND END PANELS

AT THE CONTRACTOR'S DISCRETION, COPING AND END PANELS MAY BE CAST-IN-PLACE OR PRECAST. THE PLANS DETAIL THE CAST-IN-PLACE OPTION.

ALL CAST-IN-PLACE CONCRETE IN THE COPING AND END PANELS SHALL BE CLASS A.

CONSTRUCTION JOINTS IN COPING ARE PERMITTED AT 30 FOOT SPACING.

EXPANSION JOINTS IN COPING SHALL BE PROVIDED AT 90 FOOT MAX. SPACING.

EXISTING WINGWALLS HAVE PERIODIC COUNTERFORTS / BUTTRESSES PROJECTING FROM THE FILL FACE. FILL FACE PORTIONS OF COPING SHALL BE TERMINATED WHERE COUNTERFORTS INTERSECT THE COPING.

AT THE CONTRACTOR'S DISCRETION, LUMINAIRE SUPPORT BLOCKS MAY BE CLASS A CONCRETE OR SHOTCRETE.

UTILITY COORDINATION

THE CONTRACTOR SHALL VERIFY THE LOCATION OF DRAINAGE STRUCTURES AND UTILITIES PRIOR TO COMMENCING EXCAVATION OR PILE INSTALLATION.

SOIL NAIL WINGWALL EXTENSIONS

FOR SOIL NAIL RETAINING WALLS, SEE SPECIAL PROVISIONS.

CAST-IN-PLACE CONCRETE CONSTRUCTION AT EXISTING PORTALS AND WINGWALLS

CAST-IN-PLACE CORBEL AND OPTIONAL VENEER LEDGE ALONG EXISTING WINGWALLS SHALL BE CLASS A.

TOTAL BILL OF MATERIAL

SHOTCRETE REPAIRS	EPOXY RESIN INJECTION	GRAFFITI RESISTANT COATING	UNCLASSIFIED STRUCTURE EXCAVATION	PILE EXCAVATION IN SOIL	PILE EXCAVATION NOT IN SOIL	SOLDIER PILE RETAINING WALLS	CLASS 'A' CONCRETE (1)	REINFORCING STEEL (2)	4" CONCRETE SIDEWALK (3)	ANCHORED VENEER (4)	VINYL COATED CHAIN LINK FENCE, 48" FABRIC
CU. FT.	L.F.	SQ. FT.	LUMP SUM	L.F.	L.F.	SQ. FT.	CU. YDS.	LBS.	SQ. YDS.	SQ. FT.	L.F.
587	146	19,800	LUMP SUM	98	20.5	435	66.5	9,003	205	9,000	583

- (1) INCLUDES 10.0 CU. YDS. CLASS 'A' CONCRETE FOR OPTIONAL WINGWALL VENEER LEDGE.
- (2) INCLUDES 1800 LBS. REINFORCING STEEL FOR OPTIONAL WINGWALL VENEER LEDGE.
- (3) INCLUDES REMOVAL OF EXISTING SIDEWALK FROM STA. 11+00 -L- TO STA. 15+89 -L-.
- (4) ASSUMES OPTIONAL WINGWALL VENEER LEDGE IS UTILIZED. VENEER ASSUMED TO HAVE AVG. DEPTH OF 1.0 FT BELOW PROPOSED GROUNDLINE.

PROJECT NO. U-4014

BUNCOMBE COUNTY

STATION: _____



STATE OF NORTH CAROLINA
DEPARTMENT OF TRANSPORTATION
RALEIGH

GENERAL NOTES & TOTAL BILL OF MATERIAL

REVISIONS						SHEET NO. S-2
NO.	BY:	DATE:	NO.	BY:	DATE:	
1			3			TOTAL SHEETS 30
2			4			

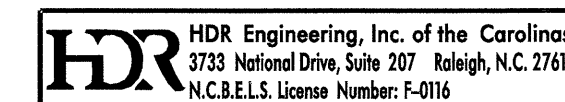

DRAWN BY : M. SELLS DATE : 07/12
CHECKED BY : J. TAYLOR DATE : 07/12

PLOT DRIVER: NCDOT_pdf_mono_eng_50.plt
USER: msells DATE: 9/10/2012
FILE: North Carolina Dept. of Transportation\NCDOT_U-4014_McDowell\Structure\U4014_SD_0N_01.dgn

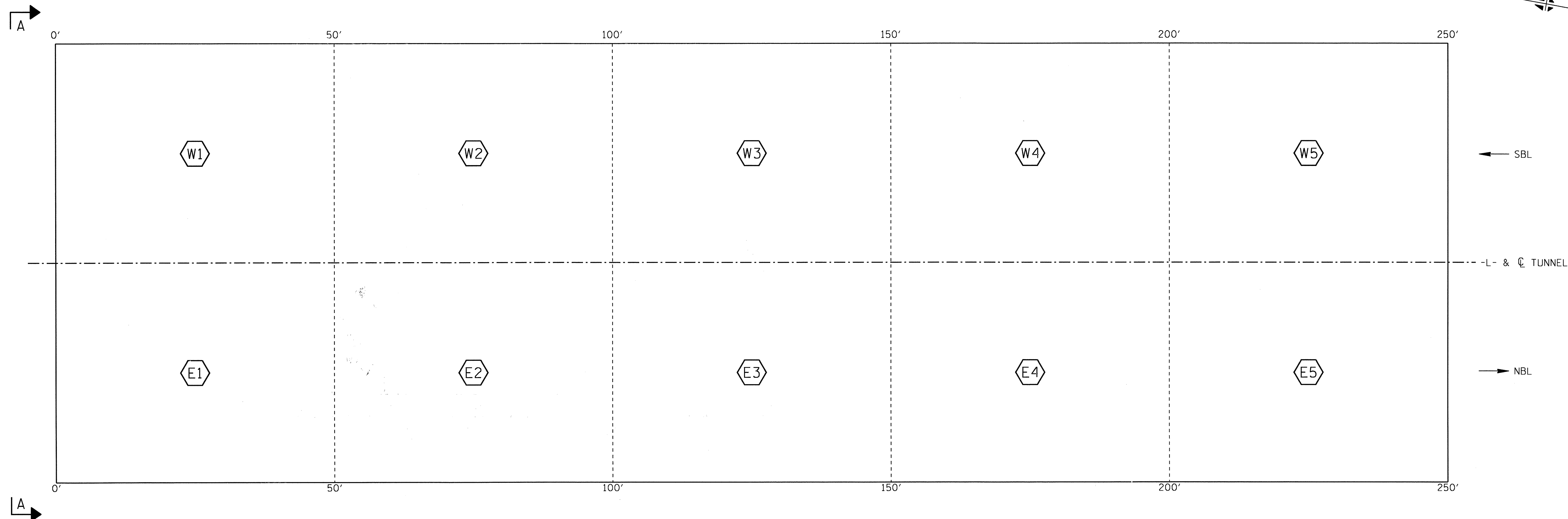

PLAN-REPAIR SEGMENT LAYOUT

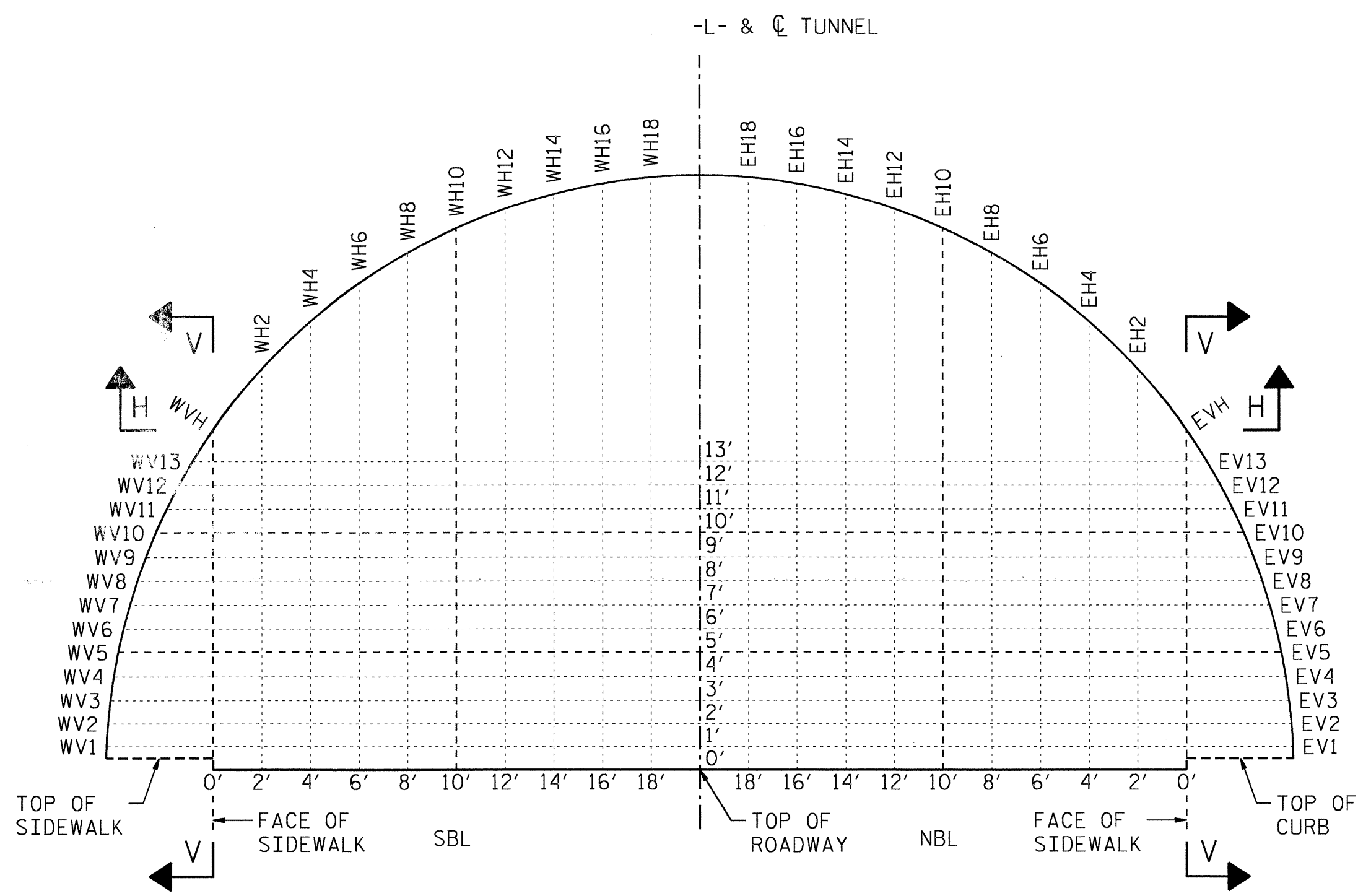

VIEW A-A

REPAIR GRID REFERENCE DETAIL

PROJECT NO. U-4014
BUNCOMBE COUNTY
 STATION: _____



STATE OF NORTH CAROLINA
 DEPARTMENT OF TRANSPORTATION
 RALEIGH
 TUNNEL REPAIR AREAS
 SEGMENT LAYOUT &
 GRID REFERENCE DETAIL

REVISIONS						SHEET NO. S-3
NO.	BY:	DATE:	NO.	BY:	DATE:	
1			3			TOTAL SHEETS 30
2			4			

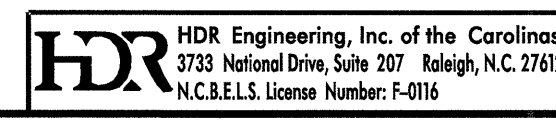

DRAWN BY : M.J. SELLS DATE : 05/11
 CHECKED BY : J.B. TAYLOR DATE : 05/11

PLOT DRIVER: NCDOT_pdf_mono_eng_50.plt
 USER: msells
 FILE: North Carolina Dept. of Transportation\NCDOT_U-4014_McDowell_Sheet\13.00_CAD\U-4014\Structures\U4014_SD_RA01_01.dgn
 PENTABLE: MDT_pen.tbl
 DATE: 9/7/2012
 TIME: 1:41:02 PM

PLOT DRIVER: NCDOT_pdf_mono_eng_50.plt
 USER: msells
 DATE: 9/7/2012
 TIME: 1:41:11 PM
 FILE: North Carolina Dept. of Transportation\NCDOT_U_4014_Medwell_Strip\13.00_CAD\U-4014_Structures\U4014_SD_RA02_01.dgn

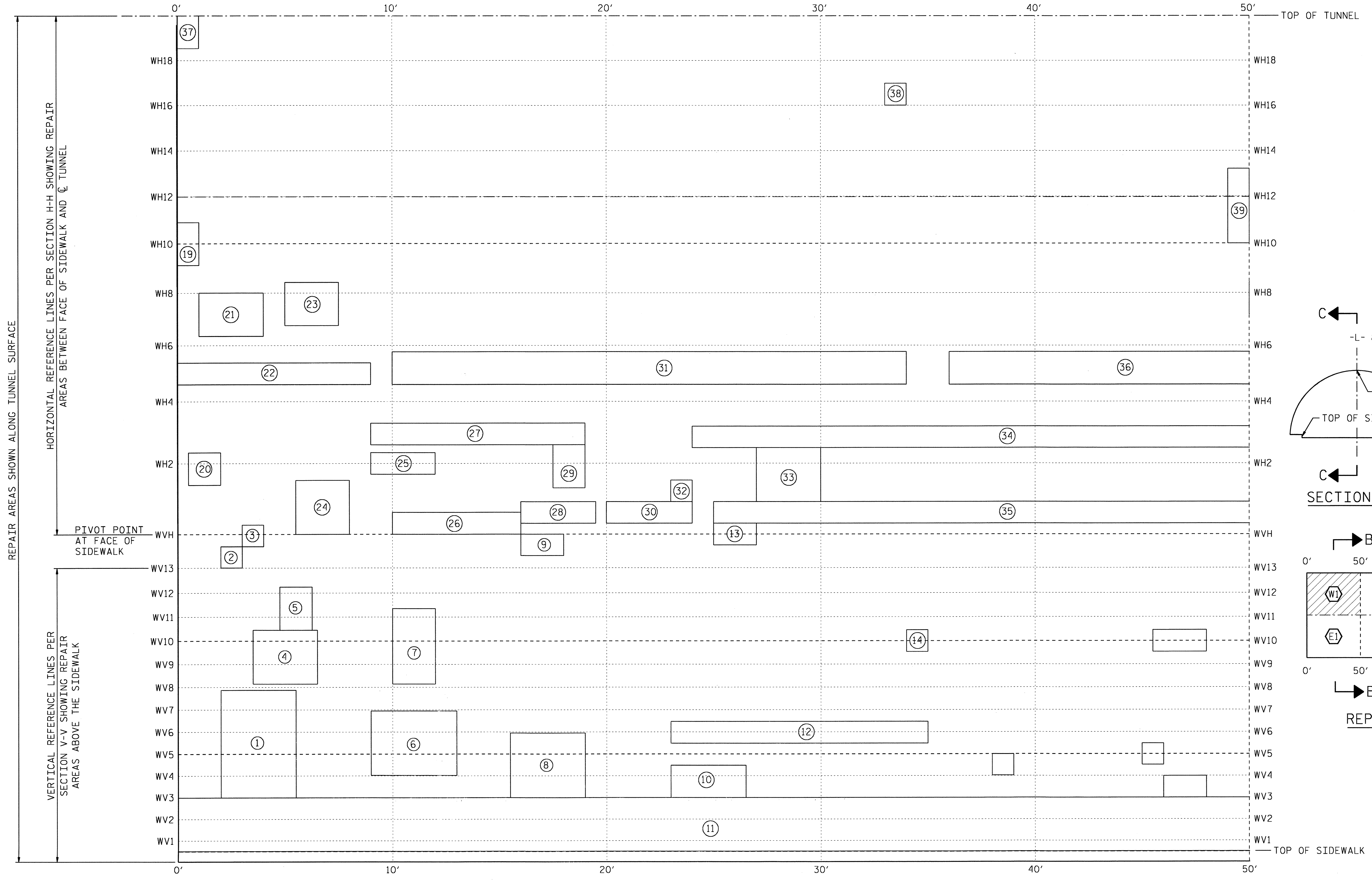

CONCRETE REPAIR AREAS				
NO.	TYPE	WIDTH	LENGTH	AREA (SF)
1	1	3'-6"	5'-0"	17.5
2	1	1'-0"	1'-0"	1.0
3	1	1'-0"	1'-0"	1.0
4	1	3'-0"	2'-6"	7.5
5	1	1'-6"	2'-0"	3.0
6	1	4'-0"	3'-0"	12.0
7	1	2'-0"	3'-6"	7.0
8	1	3'-6"	3'-0"	10.5
9	1	2'-0"	1'-0"	2.0
10	1	3'-6"	1'-6"	5.3
11	1	50'-0"	3'-0"	150.0
12	1	12'-0"	1'-0"	12.0
13	1	2'-0"	1'-0"	2.0
14	1	1'-0"	1'-0"	1.0
15	1	1'-0"	1'-0"	1.0
16	1	1'-0"	1'-0"	1.0
17	1	2'-6"	1'-0"	2.5
18	1	2'-0"	1'-0"	2.0
19	3	1'-0"	2'-0"	2.0
20	1	1'-6"	1'-6"	2.3
21	1	3'-0"	2'-0"	6.0
22	1	9'-0"	1'-0"	9.0
23	1	2'-6"	2'-0"	5.0
24	1	2'-6"	2'-6"	6.3
25	1	3'-0"	1'-0"	3.0
26	1	6'-0"	1'-0"	6.0
27	1	10'-0"	1'-0"	10.0
28	1	3'-6"	1'-0"	3.5
29	1	1'-6"	2'-0"	3.0
30	1	4'-0"	1'-0"	4.0
31	1	24'-0"	1'-6"	36.0
32	1	1'-0"	1'-0"	1.0
33	1	3'-0"	2'-6"	7.5
34	1	26'-0"	1'-0"	26.0
35	1	25'-0"	1'-0"	25.0
36	1	14'-0"	1'-6"	21.0
37	3	1'-0"	1'-6"	1.5
38	1	1'-0"	1'-0"	1.0
39	1	1'-0"	3'-6"	3.5
TYPE 1 CNCT. REPAIR AREA = 417.3				
TYPE 2 CNCT. REPAIR AREA = 0.0				
TYPE 3 CNCT. REPAIR AREA = 3.5				
TYPE 4 CNCT. REPAIR AREA = 0.0				

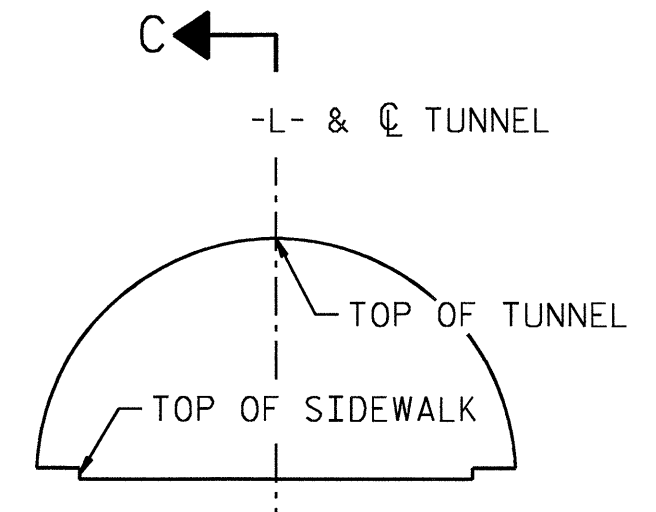

SECTION B-B

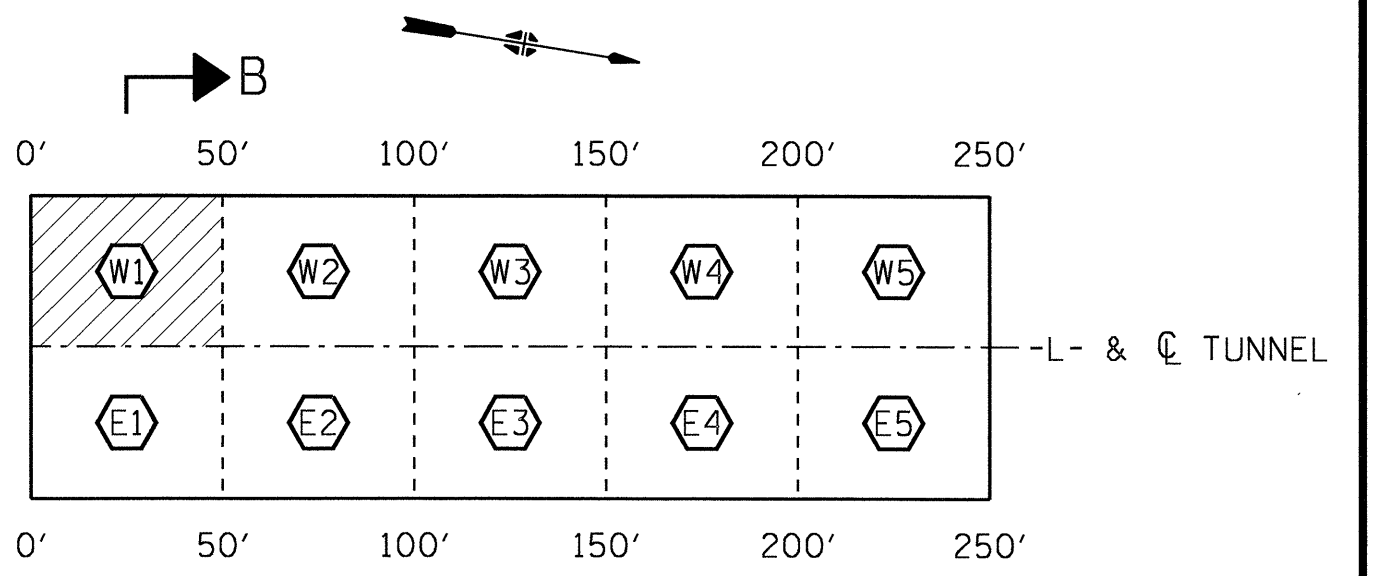

REPAIR SEGMENT LEGEND

PROJECT NO. U-4014
 BUNCOMBE COUNTY
 STATION: _____

NOTES
 FOR SECTIONS V-V AND H-H, SEE VIEW A-A ON "SEGMENT LAYOUT & GRID REFERENCE DETAIL" SHEET.

VIEW C-C: REPAIR SEGMENT W1 - TUNNEL SURFACE ELEVATION

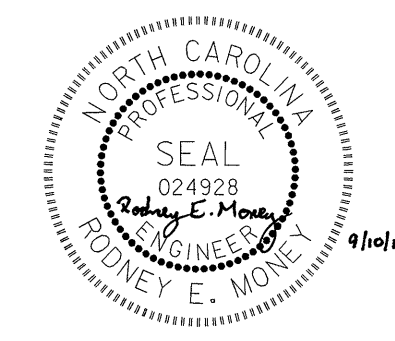

STATE OF NORTH CAROLINA
 DEPARTMENT OF TRANSPORTATION
 RALEIGH

**TUNNEL REPAIR
 AREAS SEGMENT W1**

DRAWN BY: M.J. SELLS DATE: 09/12
 CHECKED BY: J.B. TAYLOR DATE: 09/12

HDR HDR Engineering, Inc. of the Carolinas
 3733 National Drive, Suite 207 Raleigh, N.C. 27612
 N.C.B.E.L.S. License Number: F-0116

REVISIONS						SHEET NO. S-4
NO.	BY:	DATE:	NO.	BY:	DATE:	
1			3			TOTAL SHEETS 30
2			4			

CONCRETE REPAIR AREAS				
NO.	TYPE	WIDTH	LENGTH	AREA (SF)
1	1	1'-0"	1'-6"	1.5
2	1	2'-6"	3'-0"	7.5
3	1	9'-0"	1'-0"	9.0
4	1	1'-6"	1'-6"	2.3
5	1	1'-0"	1'-0"	1.0
6	1	3'-6"	1'-0"	3.5
7	1	5'-0"	2'-0"	10.0
8	1	3'-6"	1'-6"	5.3
9	1	2'-0"	1'-0"	2.0
10	1	50'-0"	3'-0"	150.0
11	1	1'-0"	1'-0"	1.0
12	1	1'-0"	1'-0"	1.0
13	1	2'-0"	1'-0"	2.0
14	1	3'-6"	2'-0"	7.0
15	1	1'-0"	4'-6"	4.5
16	1	7'-0"	1'-0"	7.0
17	1	1'-6"	1'-6"	2.3
18	1	1'-6"	1'-6"	2.3
19	1	34'-0"	1'-0"	34.0
20	1	38'-0"	1'-6"	57.0
21	1	8'-0"	1'-0"	8.0
22	1	1'-0"	1'-0"	1.0
23	4	10'-0"	18'-0"	180.0
TYPE 1 CNCT. REPAIR AREA =				319.0
TYPE 2 CNCT. REPAIR AREA =				0.0
TYPE 3 CNCT. REPAIR AREA =				0.0
TYPE 4 CNCT. REPAIR AREA =				180.0

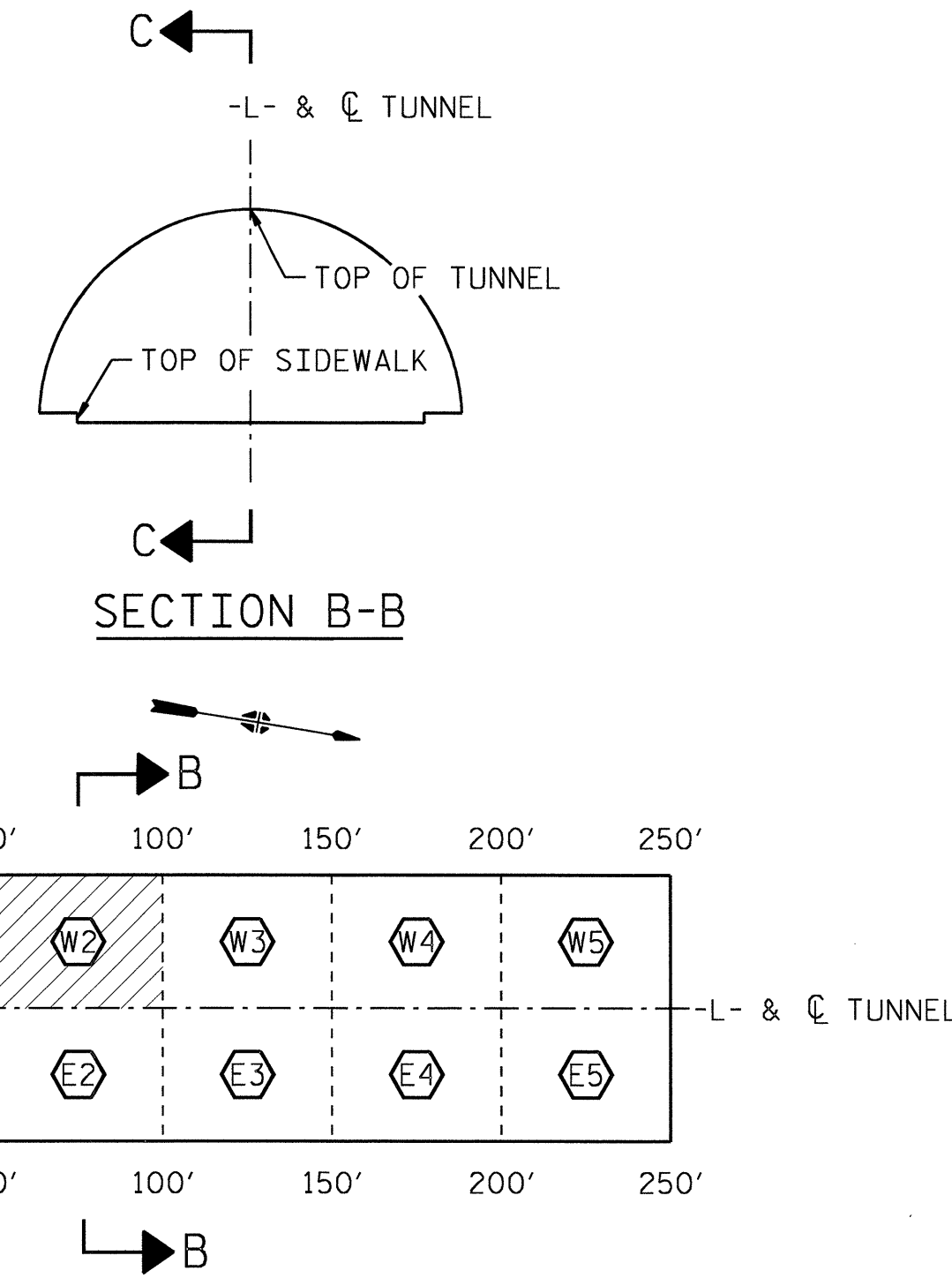
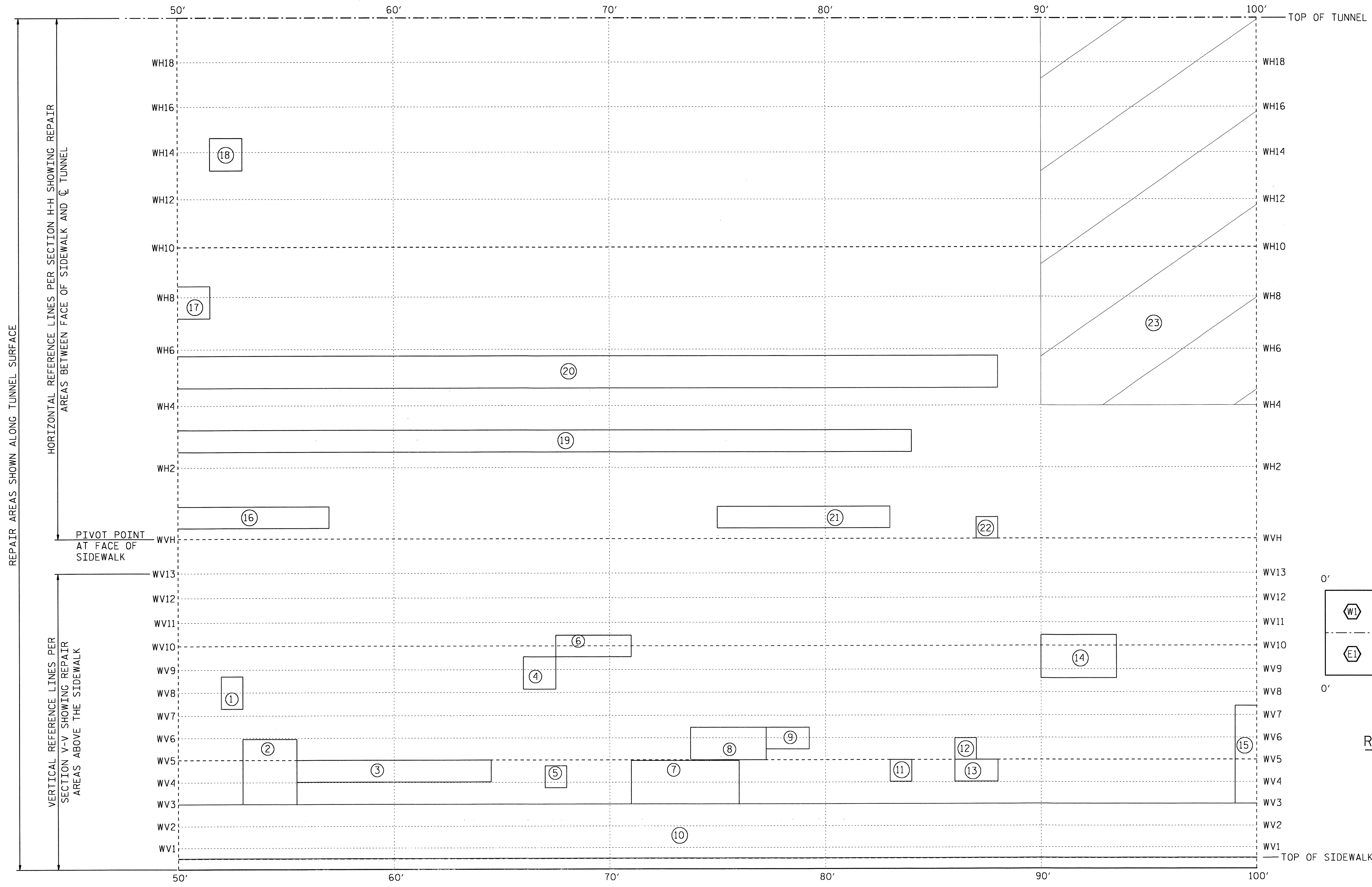

PROJECT NO. U-4014
 BUNCOMBE COUNTY
 STATION: _____

NOTES
 FOR SECTIONS V-V AND H-H, SEE VIEW A-A ON "SEGMENT LAYOUT & GRID REFERENCE DETAIL" SHEET.
 HATCHED REPAIR AREA CONSISTS OF DELAMINATING GROUT FINISH.

VIEW C-C: REPAIR SEGMENT W2 - TUNNEL SURFACE ELEVATION



STATE OF NORTH CAROLINA
 DEPARTMENT OF TRANSPORTATION
 RALEIGH

TUNNEL REPAIR AREAS SEGMENT W2

DRAWN BY: M.J. SELLS DATE: 09/12
 CHECKED BY: J.B. TAYLOR DATE: 09/12

HDR Engineering, Inc. of the Carolinas
 3733 National Drive, Suite 207 Raleigh, N.C. 27612
 N.C.B.E.L.S. License Number: F-0116

REVISIONS						SHEET NO. 5-5
NO.	BY:	DATE:	NO.	BY:	DATE:	
1			3			TOTAL SHEETS 30
2			4			

PLOT DRIVER: NCDOT_pdf_mono_eng_50.plt
 USER: msells
 FILE: North Carolina Dept. of Transportation\NCDOT_U_4014_McDowell_Street\13.00_CAD\U-4014_Structures\U4014_SD_RA03_01.dgn
 PENTABLE: MDT_pen.tbl
 DATE: 9/7/2012
 TIME: 1:41:22 PM

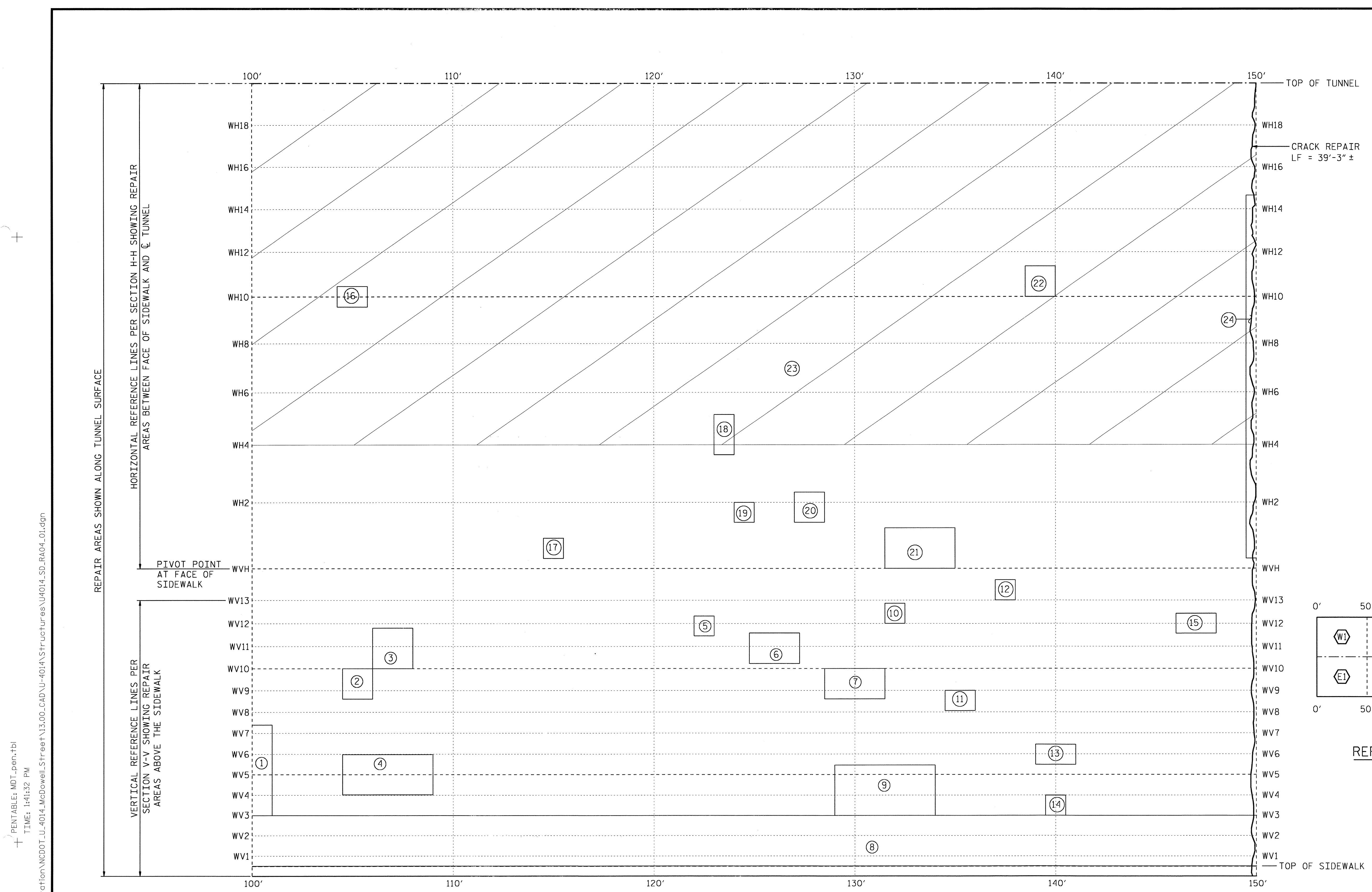

CONCRETE REPAIR AREAS				
NO.	TYPE	WIDTH	LENGTH	AREA (SF)
1	1	1'-0"	4'-6"	4.5
2	1	1'-6"	1'-6"	2.3
3	1	2'-0"	2'-0"	4.0
4	1	4'-6"	2'-0"	9.0
5	1	1'-0"	1'-0"	1.0
6	1	2'-6"	1'-6"	3.8
7	1	3'-0"	1'-6"	4.5
8	1	50'-0"	3'-0"	150.0
9	1	5'-0"	2'-6"	12.5
10	1	1'-0"	1'-0"	1.0
11	1	1'-6"	1'-0"	1.5
12	1	1'-0"	1'-0"	1.0
13	1	2'-0"	1'-0"	2.0
14	1	1'-0"	1'-0"	1.0
15	1	2'-0"	1'-0"	2.0
16	1	1'-6"	1'-0"	1.5
17	1	1'-0"	1'-0"	1.0
18	1	1'-0"	2'-0"	2.0
19	1	1'-0"	1'-0"	1.0
20	1	1'-6"	1'-6"	2.3
21	1	3'-6"	2'-0"	7.0
22	1	1'-6"	1'-6"	2.3
23	4	50'-0"	18'-0"	900.0
24	1	0'-6"	18'-0"	9.0
TYPE 1 CNCT. REPAIR AREA = 226.0				
TYPE 2 CNCT. REPAIR AREA = 0.0				
TYPE 3 CNCT. REPAIR AREA = 0.0				
TYPE 4 CNCT. REPAIR AREA = 900.0				

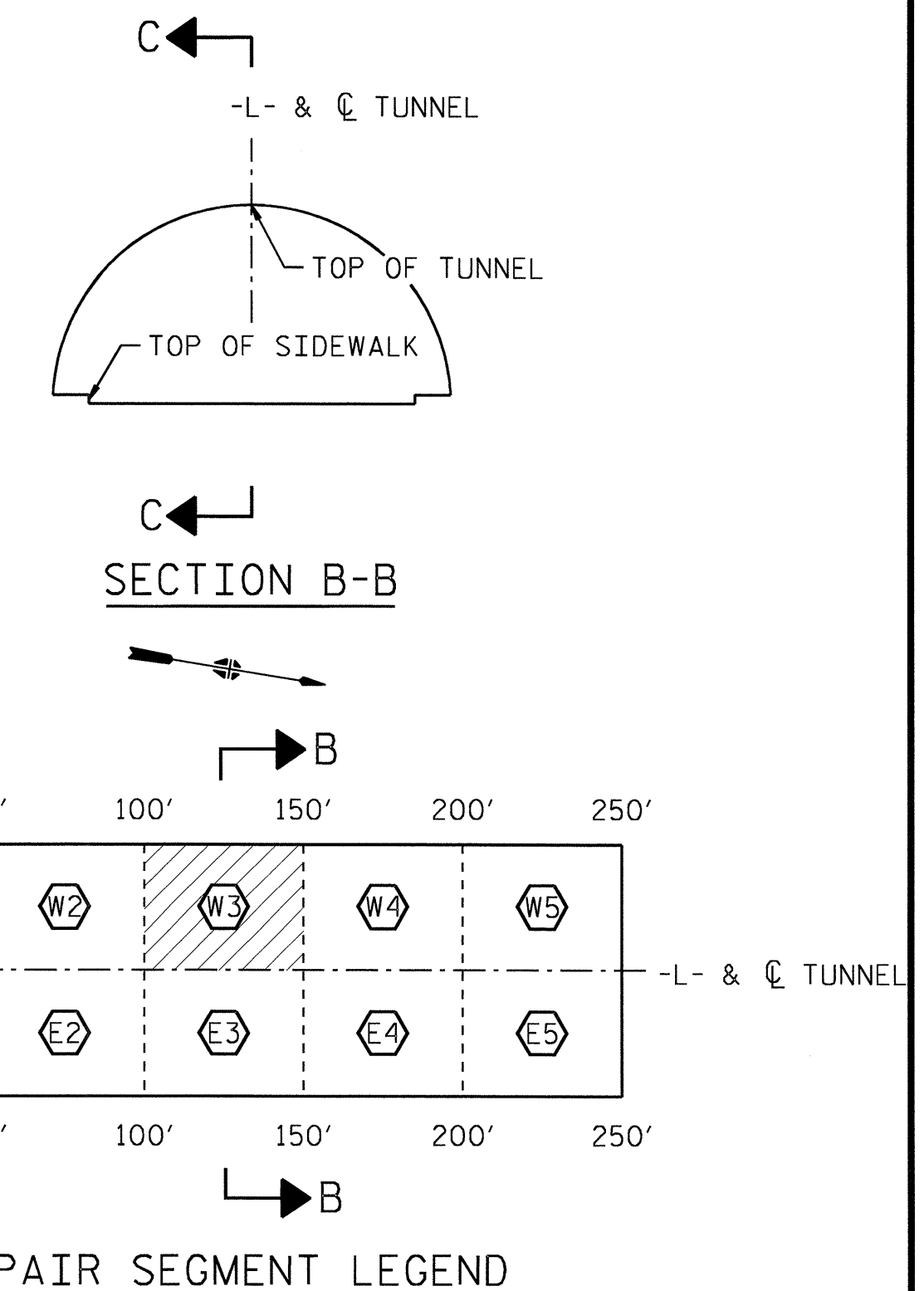

PROJECT NO. U-4014
 BUNCOMBE COUNTY
 STATION: _____

NOTES
 FOR SECTIONS V-V AND H-H, SEE VIEW A-A ON "SEGMENT LAYOUT & GRID REFERENCE DETAIL" SHEET.

HATCHED REPAIR AREA CONSISTS OF DELAMINATING GROUT FINISH. SMALLER REPAIR AREAS INDICATED WITHIN THE HATCHED REPAIR AREA REPRESENT AREAS WHERE DAMAGE TO THE UNDERLYING TUNNEL CONCRETE HAS BEEN IDENTIFIED.

VIEW C-C: REPAIR SEGMENT W3 - TUNNEL SURFACE ELEVATION

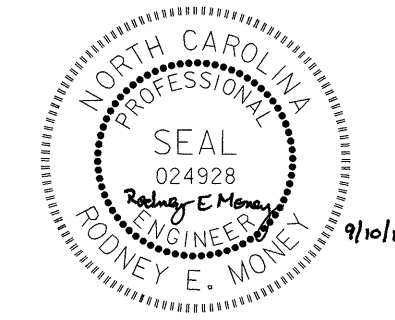

STATE OF NORTH CAROLINA
 DEPARTMENT OF TRANSPORTATION
 RALEIGH

TUNNEL REPAIR AREAS SEGMENT W3

DRAWN BY: M.J. SELLS DATE: 09/12
 CHECKED BY: J.B. TAYLOR DATE: 09/12

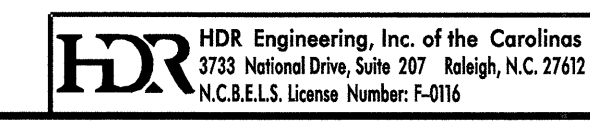

REVISIONS					
NO.	BY:	DATE:	NO.	BY:	DATE:
1			3		
2			4		

SHEET NO. 56
 TOTAL SHEETS 30

PLOT DRIVER: NCDOT_pdf_mono_eng_50.pht
 USER: msells
 FILE: North Carolina Dept. of Transportation\NCDOT_U-4014_McDowell_Strip\13000_CAD\U-4014_Structures\U4014_SD_RA04_01.dgn
 DATE: 9/7/2012
 TIME: 1:41:32 PM

PLOT DRIVER: NCDOT_pdf_mono_eng_50.plt
 USER: msells
 PENTABLE: MDT_pen.tbl
 DATE: 9/7/2012
 TIME: 1:41:41 PM
 FILE: North Carolina Dept. of Transportation\NCDOT_U_4014_McDowell\Structure\U4014_SD_RA05_01.dgn

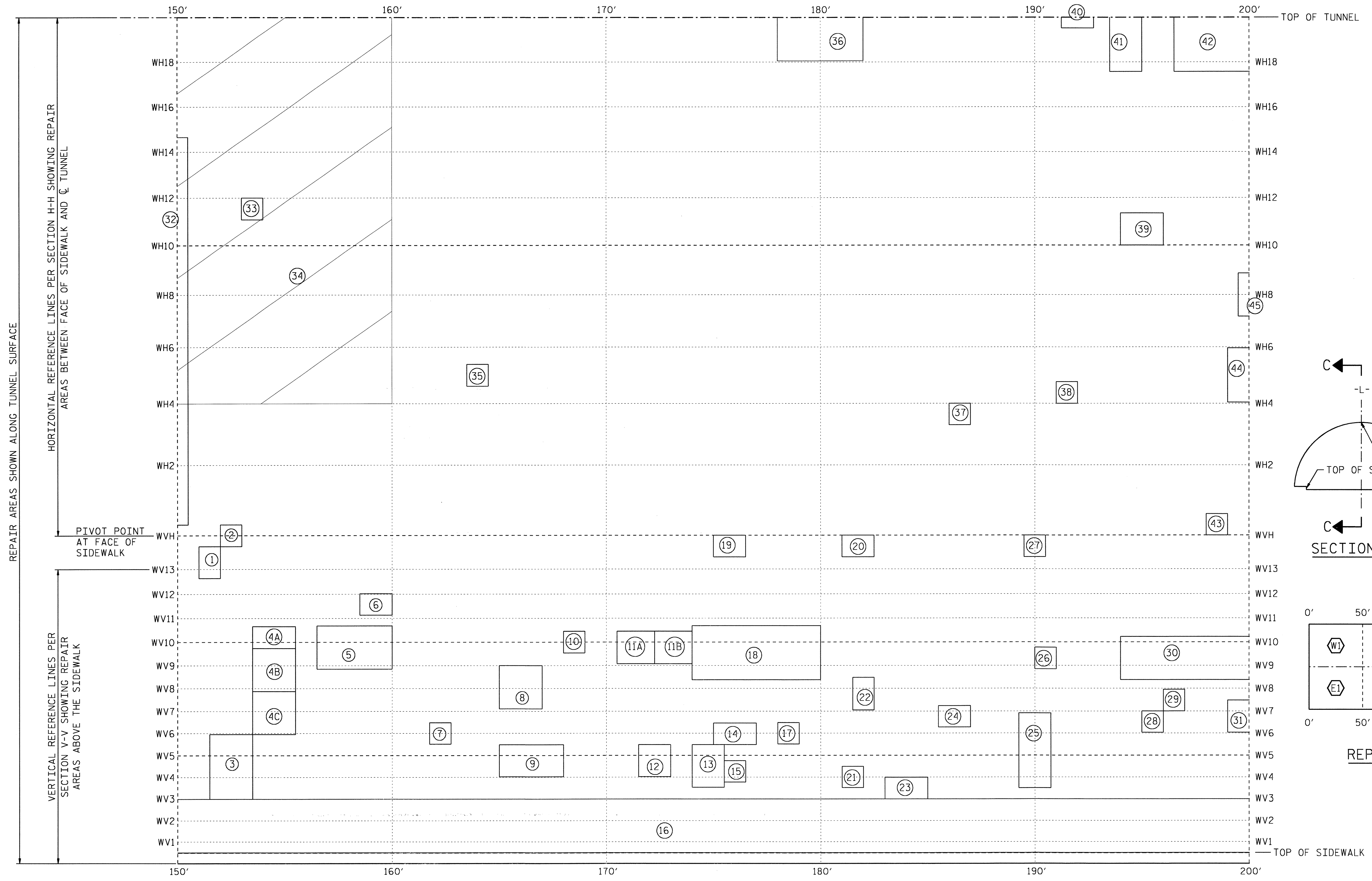

CONCRETE REPAIR AREAS				
NO.	TYPE	WIDTH	LENGTH	AREA (SF)
1	1	1'-0"	1'-6"	1.5
2	1	1'-0"	1'-0"	1.0
3	1	2'-0"	3'-0"	6.0
4A	3	2'-0"	1'-0"	2.0
4B	1	2'-0"	2'-0"	4.0
4C	1	2'-0"	2'-0"	4.0
5	1	3'-6"	2'-0"	7.0
6	1	1'-6"	1'-0"	1.5
7	1	1'-0"	1'-0"	1.0
8	1	2'-0"	2'-0"	4.0
9	1	3'-0"	1'-6"	4.5
10	1	1'-0"	1'-0"	1.0
11A	1	1'-9"	1'-6"	2.6
11B	3	1'-9"	1'-6"	2.6
12	1	1'-6"	1'-6"	2.3
13	1	1'-6"	2'-0"	3.0
14	1	2'-0"	1'-0"	2.0
15	1	1'-0"	1'-0"	1.0
16	1	50'-0"	3'-0"	150.0
17	1	1'-0"	1'-0"	1.0
18	3	6'-0"	2'-6"	15.0
19	1	1'-6"	1'-0"	1.5
20	1	1'-6"	1'-0"	1.5
21	1	1'-0"	1'-0"	1.0
22	1	1'-0"	1'-6"	1.5
23	1	2'-0"	1'-0"	2.0
24	1	1'-6"	1'-0"	1.5
25	1	1'-6"	3'-6"	5.3
26	1	1'-0"	1'-0"	1.0
27	1	1'-0"	1'-0"	1.0
28	1	1'-0"	1'-0"	1.0
29	1	1'-0"	1'-0"	1.0
30	3	6'-0"	2'-0"	12.0
31	1	1'-0"	1'-6"	1.5
32	1	0'-6"	18'-0"	9.0
33	1	1'-0"	1'-0"	1.0
34	4	10'-0"	18'-0"	180.0
35	1	1'-0"	1'-0"	1.0
36	1	4'-0"	2'-0"	8.0
37	1	1'-0"	1'-0"	1.0
38	1	1'-0"	1'-0"	1.0
39	1	2'-0"	1'-6"	3.0
40	3	1'-6"	0'-6"	0.8
41	3	1'-6"	2'-6"	3.8
42	1	3'-6"	2'-6"	8.8
43	1	1'-0"	1'-0"	1.0
44	1	1'-3"	2'-0"	2.5
45	1	0'-6"	1'-6"	0.8

TYPE 1 CNCT. REPAIR AREA = 252.1
 TYPE 2 CNCT. REPAIR AREA = 0.0
 TYPE 3 CNCT. REPAIR AREA = 38.1
 TYPE 4 CNCT. REPAIR AREA = 180.0

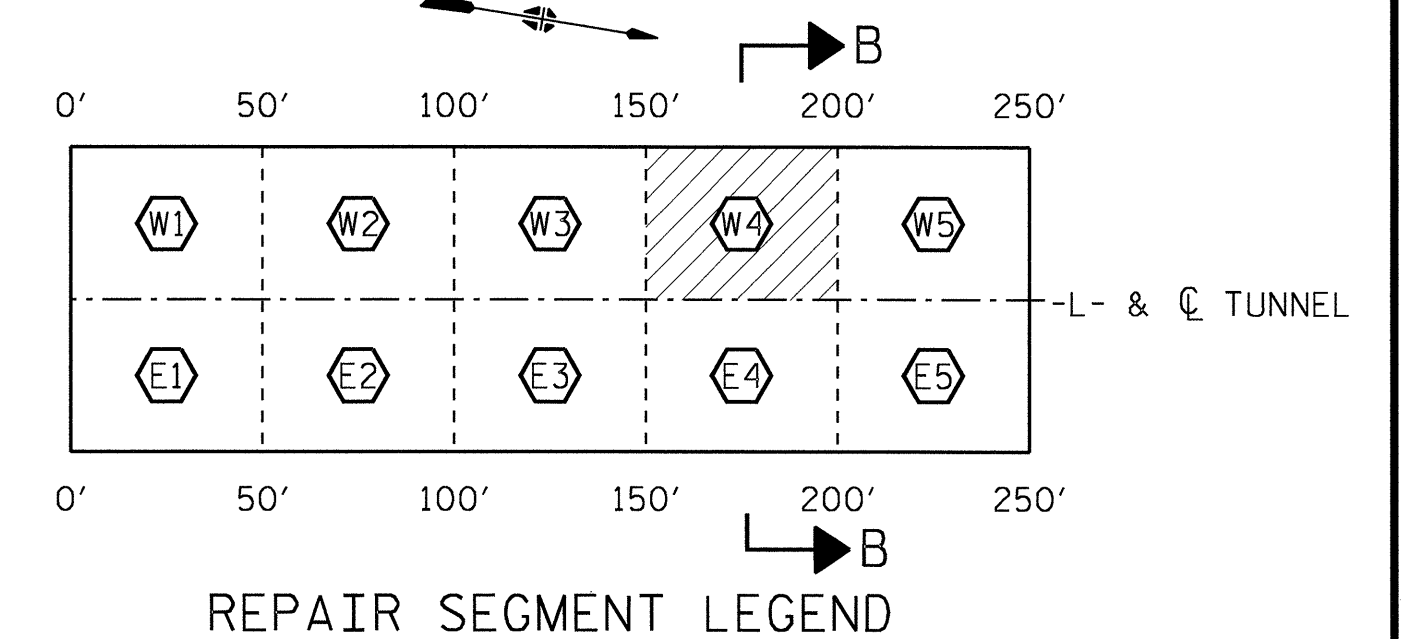
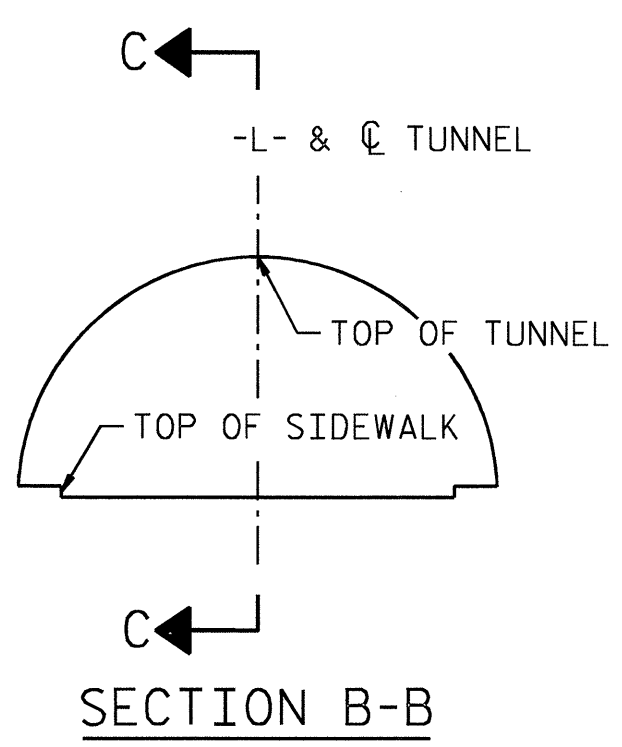

PROJECT NO. U-4014
 BUNCOMBE COUNTY
 STATION:

NOTES
 FOR SECTIONS V-V AND H-H, SEE VIEW A-A ON "SEGMENT LAYOUT & GRID REFERENCE DETAIL" SHEET.

HATCHED REPAIR AREA CONSISTS OF DELAMINATING GROUT FINISH. SMALLER REPAIR AREAS INDICATED WITHIN THE HATCHED REPAIR AREA REPRESENT AREAS WHERE DAMAGE TO THE UNDERLYING TUNNEL CONCRETE HAS BEEN IDENTIFIED.

VIEW C-C: REPAIR SEGMENT W4 - TUNNEL SURFACE ELEVATION

DRAWN BY: M.J. SELLS DATE: 09/12
 CHECKED BY: J.B. TAYLOR DATE: 09/12



STATE OF NORTH CAROLINA
 DEPARTMENT OF TRANSPORTATION
 RALEIGH
TUNNEL REPAIR AREAS SEGMENT W4

REVISIONS						SHEET NO. 7	TOTAL SHEETS 30
NO.	BY:	DATE:	NO.	BY:	DATE:		
1			3				
2			4				

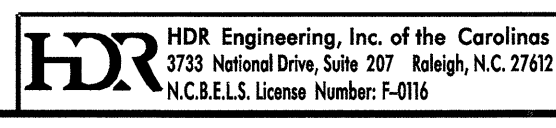

PLOT DRIVER: NCDOT_pdf_mono_eng_50.plt
 USER: msells DATE: 9/7/2012
 FILE: North Carolina Dept. of Transportation\NCDOT_U-4014_McDowell_Street\13.00_CAD\U-4014_Structures\U4014_SD_RA06_01.dgn

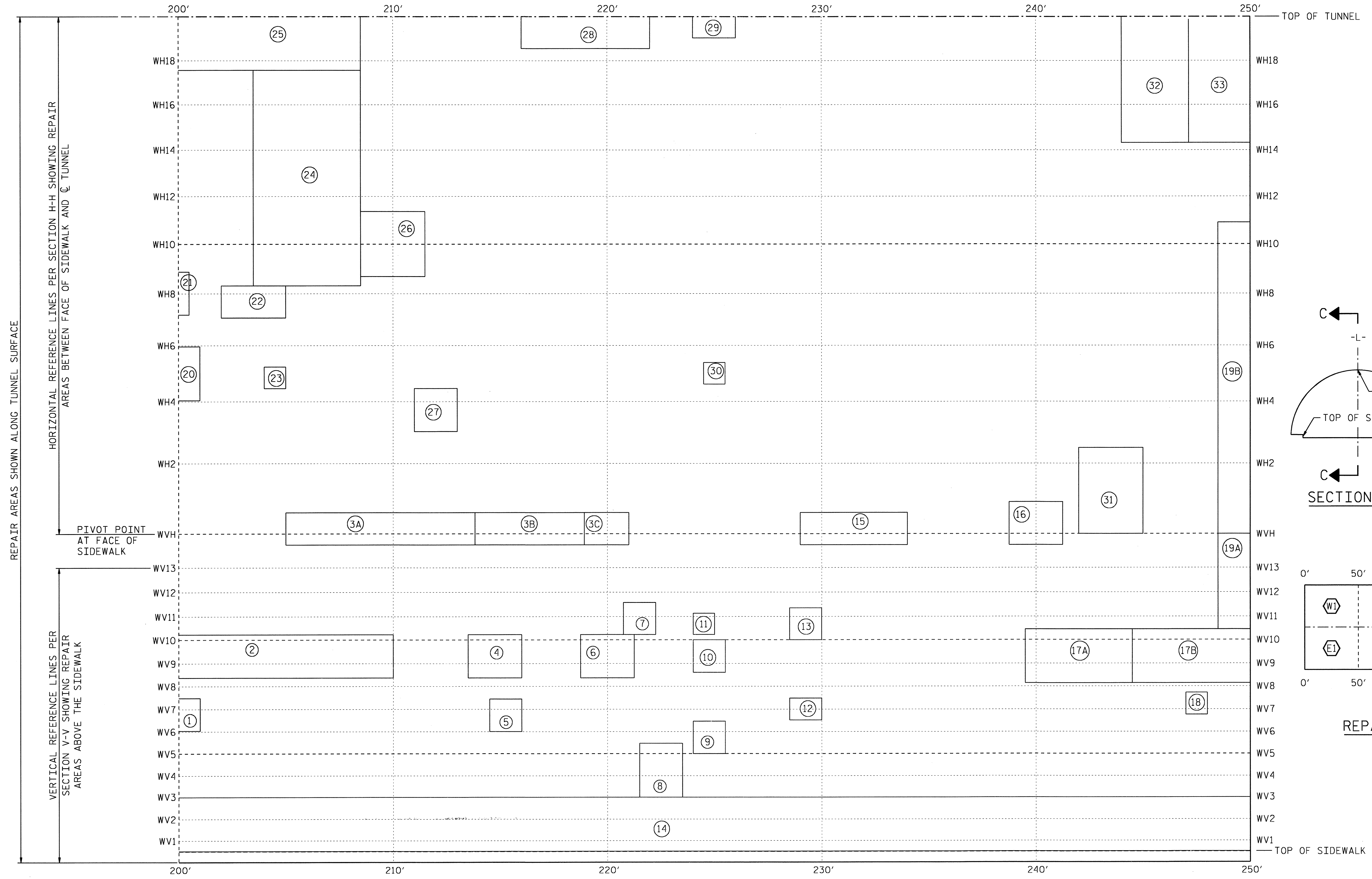

CONCRETE REPAIR AREAS				
NO.	TYPE	WIDTH	LENGTH	AREA (SF)
1	1	1'-0"	1'-6"	1.5
2	3	10'-0"	2'-0"	20.0
3A	1	9'-0"	1'-6"	13.5
3B	2	5'-0"	1'-6"	7.5
3C	1	2'-0"	1'-6"	3.0
4	1	2'-6"	2'-0"	5.0
5	1	1'-6"	1'-6"	2.3
6	1	2'-6"	2'-0"	5.0
7	1	1'-6"	1'-6"	2.3
8	1	2'-0"	2'-6"	5.0
9	1	1'-6"	1'-6"	2.3
10	1	1'-6"	1'-6"	2.3
11	1	1'-0"	1'-0"	1.0
12	1	1'-6"	1'-0"	1.5
13	1	1'-6"	1'-6"	2.3
14	1	50'-0"	3'-0"	150.0
15	1	5'-0"	1'-6"	7.5
16	1	2'-6"	2'-0"	5.0
17A	2	5'-6"	2'-6"	13.8
17B	3	5'-0"	2'-6"	12.5
18	1	1'-0"	1'-0"	1.0
19A	3	1'-6"	3'-0"	4.5
19B	1	1'-6"	16'-0"	24.0
20	1	1'-3"	2'-0"	2.5
21	1	0'-6"	1'-6"	0.8
22	1	3'-0"	1'-6"	4.5
23	1	1'-0"	1'-0"	1.0
24	1	5'-0"	10'-0"	50.0
25	1	8'-6"	2'-6"	21.3
26	1	3'-0"	3'-0"	9.0
27	1	2'-0"	2'-0"	4.0
28	1	6'-0"	1'-6"	9.0
29	1	2'-0"	1'-0"	2.0
30	1	1'-0"	1'-0"	1.0
31	1	3'-0"	4'-0"	12.0
32	1	3'-0"	6'-0"	18.0
33	1	3'-0"	6'-0"	18.0
TYPE 1 CNCT. REPAIR AREA =				387.3
TYPE 2 CNCT. REPAIR AREA =				21.3
TYPE 3 CNCT. REPAIR AREA =				37.0
TYPE 4 CNCT. REPAIR AREA =				0.0

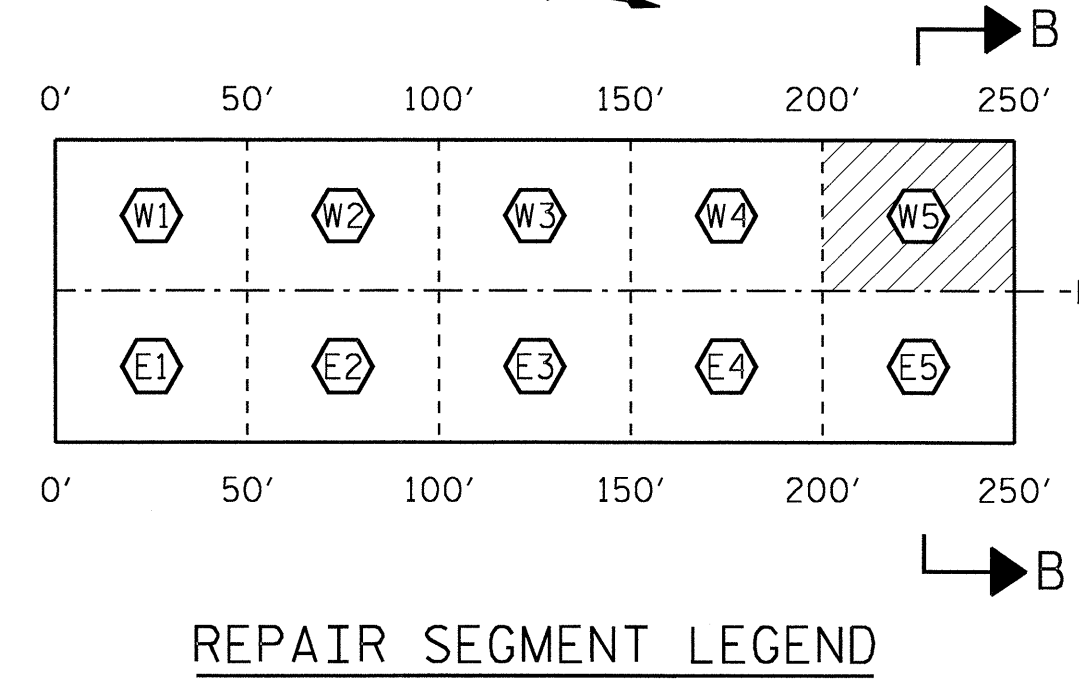
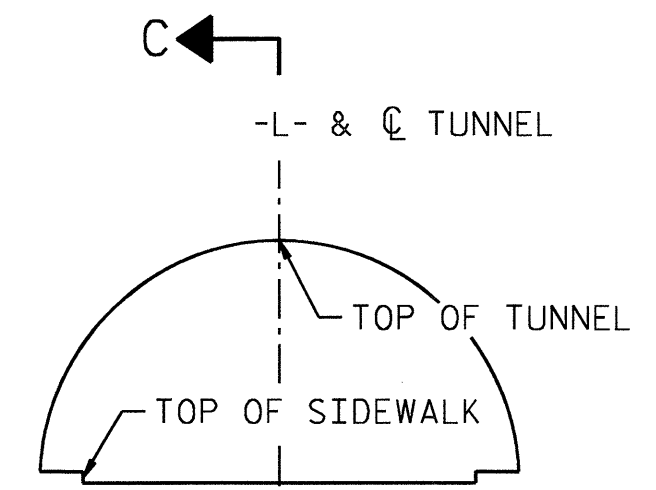

NOTES
 FOR SECTIONS V-V AND H-H, SEE VIEW A-A ON "SEGMENT LAYOUT & GRID REFERENCE DETAIL" SHEET.

VIEW C-C: REPAIR SEGMENT W5 - TUNNEL SURFACE ELEVATION

PROJECT NO. U-4014
BUNCOMBE COUNTY
 STATION: _____



STATE OF NORTH CAROLINA
 DEPARTMENT OF TRANSPORTATION
 RALEIGH

**TUNNEL REPAIR
 AREAS SEGMENT W5**

DRAWN BY: M.J. SELLS DATE: 09/12
 CHECKED BY: J.B. TAYLOR DATE: 09/12

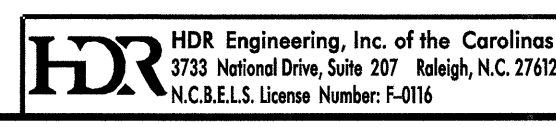

REVISIONS						SHEET NO. S-B
NO.	BY:	DATE:	NO.	BY:	DATE:	
1			3			TOTAL SHEETS 30
2			4			

CONCRETE REPAIR AREAS				
NO.	TYPE	WIDTH	LENGTH	AREA (SF)
1	1	1'-0"	6'-6"	6.5
2	3	2'-0"	1'-6"	3.0
3	3	2'-0"	1'-0"	2.0
4	1	1'-6"	1'-6"	2.3
5	1	4'-0"	2'-0"	8.0
6	1	1'-0"	1'-0"	1.0
7	1	1'-0"	1'-0"	1.0
8	1	2'-6"	2'-6"	6.3
9	1	4'-0"	2'-0"	8.0
10	1	1'-6"	1'-6"	2.3
11	1	3'-0"	1'-0"	3.0
12	2	2'-0"	1'-6"	3.0
13	2	1'-0"	1'-0"	1.0
14	1	1'-0"	1'-0"	1.0
15	1	3'-0"	1'-0"	3.0
16	1	6'-0"	2'-0"	12.0
17	1	1'-0"	1'-0"	1.0
18	3	2'-0"	1'-6"	3.0
19	2	1'-0"	1'-0"	1.0
20	1	1'-0"	1'-0"	1.0
21	1	35'-6"	1'-0"	35.5
22	1	2'-0"	1'-6"	3.0
23	1	1'-0"	1'-0"	1.0
24	1	3'-0"	1'-6"	4.5
25	1	4'-0"	2'-0"	8.0
26	1	1'-0"	1'-0"	1.0
27	1	2'-0"	1'-6"	3.0
28	1	0'-6"	1'-0"	0.5
29A	3	1'-0"	2'-0"	2.0
29B	1	1'-0"	2'-0"	2.0
30	1	4'-0"	1'-0"	4.0
31	1	1'-0"	1'-0"	1.0
32	1	1'-0"	1'-6"	1.5
33	1	1'-0"	1'-0"	1.0
34	1	2'-0"	1'-0"	2.0
35	1	1'-0"	1'-0"	1.0
36	1	2'-0"	2'-0"	4.0
37	1	3'-0"	1'-0"	3.0
38	1	36'-0"	2'-0"	72.0
39	1	3'-6"	1'-0"	3.5
40	1	1'-0"	1'-0"	1.0
41	1	1'-0"	1'-0"	1.0
42	1	0'-6"	1'-0"	0.5
43	2	1'-0"	1'-0"	1.0
44	3	1'-0"	1'-6"	1.5
45	1	2'-0"	1'-0"	2.0
46	1	0'-9"	4'-6"	3.4
TYPE 1 CNCT. REPAIR AREA =				215.6
TYPE 2 CNCT. REPAIR AREA =				6.0
TYPE 3 CNCT. REPAIR AREA =				11.5
TYPE 4 CNCT. REPAIR AREA =				0.0

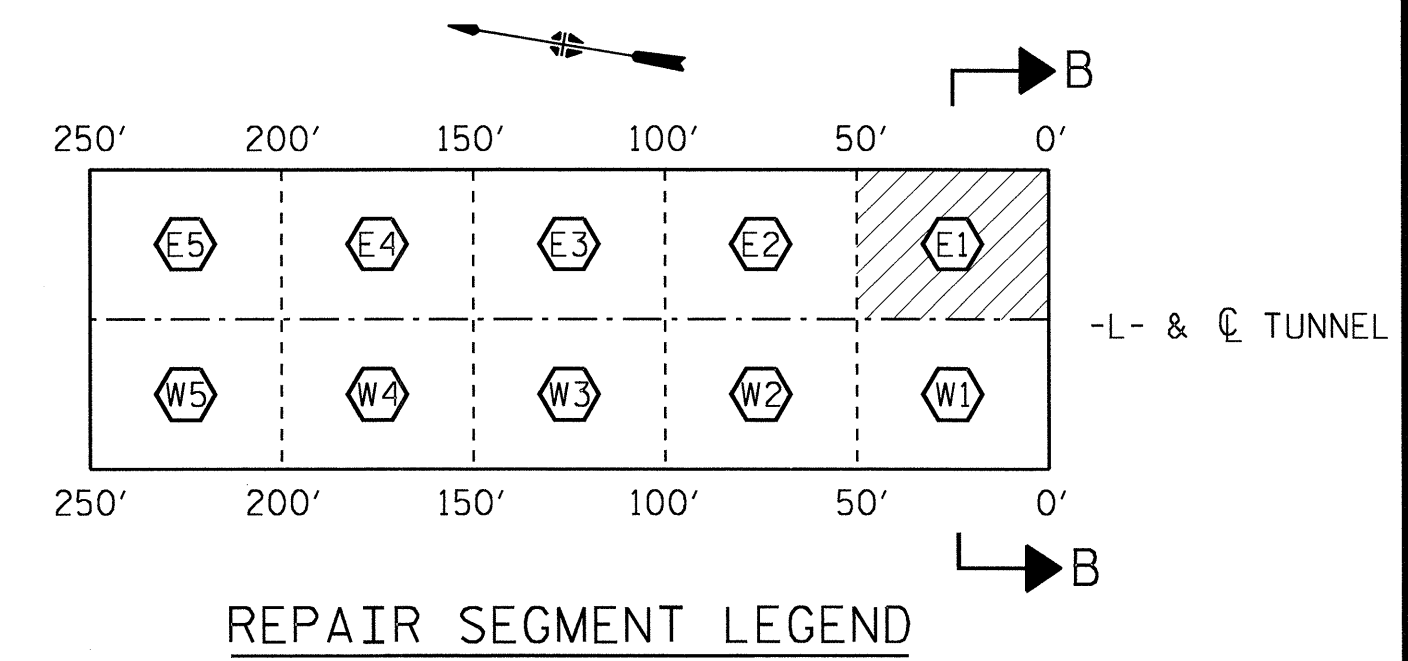
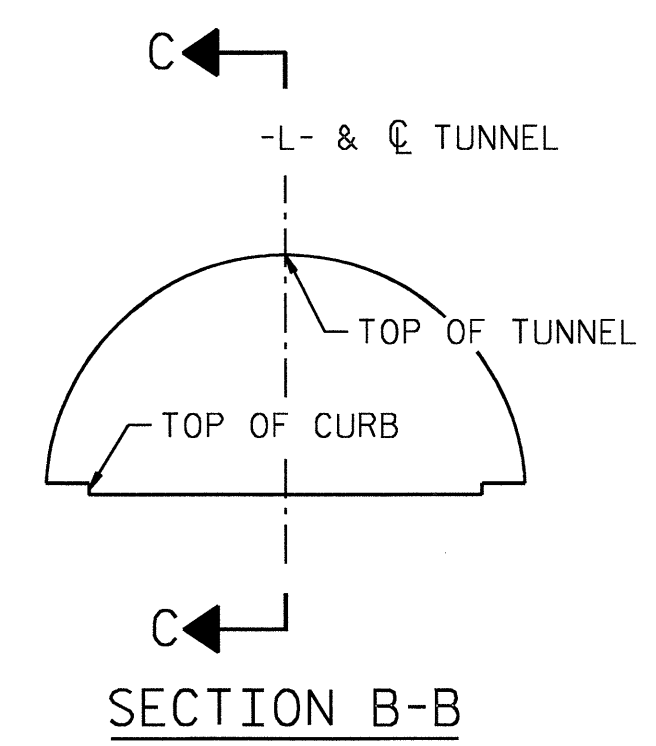

PROJECT NO. U-4014
 BUNCOMBE COUNTY
 STATION: _____



STATE OF NORTH CAROLINA
 DEPARTMENT OF TRANSPORTATION
 RALEIGH
**TUNNEL REPAIR
 AREAS SEGMENT E1**

REVISIONS					
NO.	BY:	DATE:	NO.	BY:	DATE:
1			3		
2			4		

SHEET NO. S-9
 TOTAL SHEETS 30

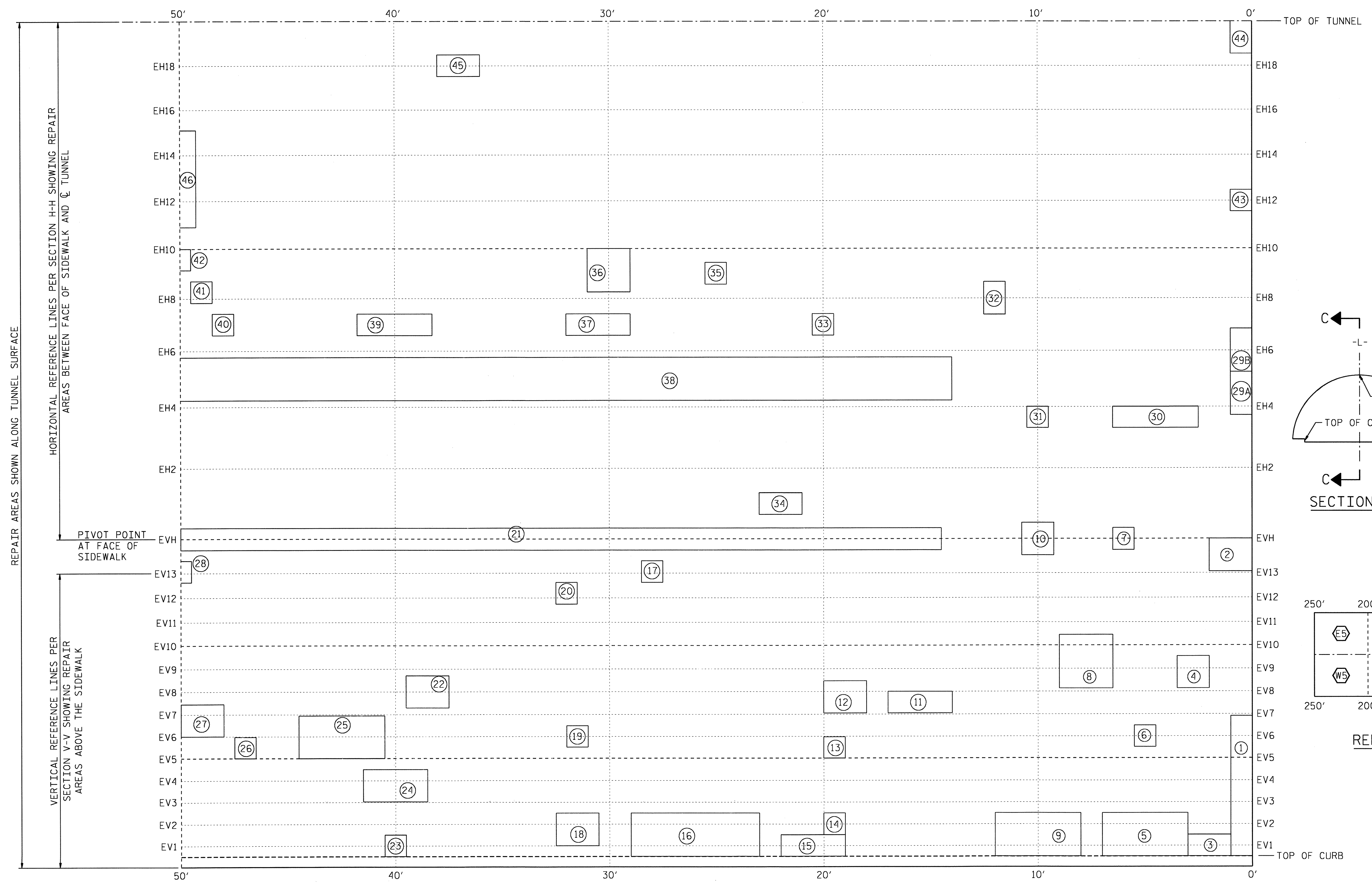

NOTES
 FOR SECTIONS V-V AND H-H, SEE VIEW A-A ON "SEGMENT LAYOUT & GRID REFERENCE DETAIL" SHEET.

VIEW C-C: REPAIR SEGMENT E1 - TUNNEL SURFACE ELEVATION

DRAWN BY: M.J. SELLS DATE: 09/12
 CHECKED BY: J.B. TAYLOR DATE: 09/12

HDR HDR Engineering, Inc. of the Carolinas
 1733 National Drive, Suite 207 Raleigh, N.C. 27612
 N.C.B.E.L.S. License Number: F-0116

PLOT DRIVER: NCDOT_pdf_mono_eng_50.plt
 USER: msells DATE: 9/7/2012
 FILE: North Carolina Dept. of Transportation\NCDOT_U-4014_McDowell Street\1300-CAD\U-4014\Structures\U4014_S01_RA07_01.dgn

PLOT DRIVER: NCDOT_pdf_mono_eng_50.plt
 USER: msells
 DATE: 9/7/2012
 TIME: 1:42:16 PM
 FILE: North Carolina Dept. of Transportation\13.00_CAD\U-4014\Structure\U4014_SD_RA08_01.dgn

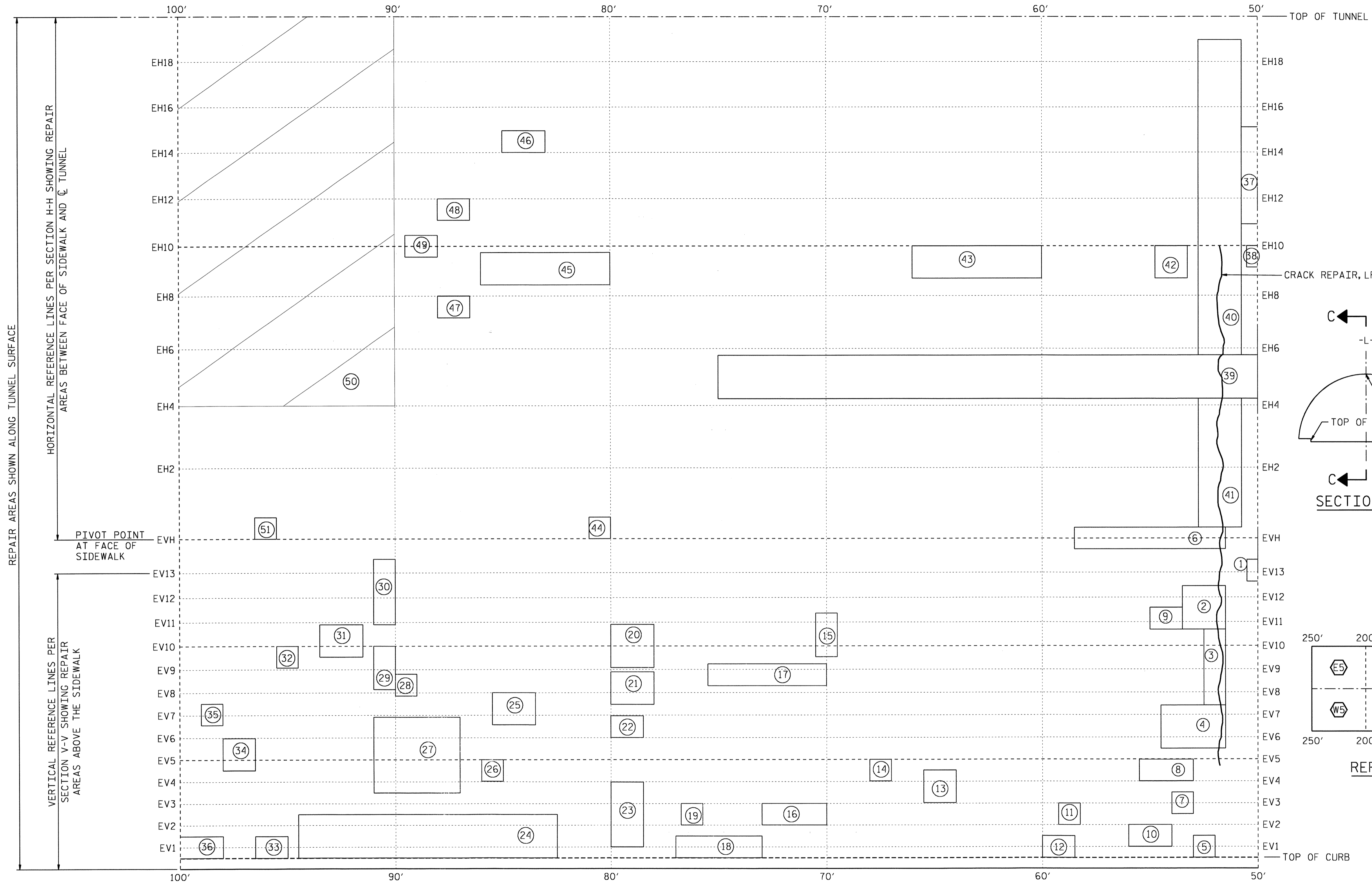

CONCRETE REPAIR AREAS				
NO.	TYPE	WIDTH	LENGTH	AREA (SF)
1	1	0'-6"	1'-0"	0.5
2	1	2'-0"	2'-0"	4.0
3	1	1'-0"	3'-6"	3.5
4	1	3'-0"	2'-0"	6.0
5	1	1'-0"	1'-0"	1.0
6	1	7'-0"	1'-0"	7.0
7	1	1'-0"	1'-0"	1.0
8	1	2'-6"	1'-0"	2.5
9	1	1'-6"	1'-0"	1.5
10	1	2'-0"	1'-0"	2.0
11	1	1'-0"	1'-0"	1.0
12	1	1'-6"	1'-0"	1.5
13	1	1'-6"	1'-6"	2.3
14	1	1'-0"	1'-0"	1.0
15	1	1'-0"	2'-0"	2.0
16	1	3'-0"	1'-0"	3.0
17	1	5'-6"	1'-0"	5.5
18	1	4'-0"	1'-0"	4.0
19	1	1'-0"	1'-0"	1.0
20	1	2'-0"	2'-0"	4.0
21	1	2'-0"	1'-6"	3.0
22	1	1'-6"	1'-0"	1.5
23	1	1'-6"	3'-0"	4.5
24	1	12'-0"	2'-0"	24.0
25	1	2'-0"	1'-6"	3.0
26	1	1'-0"	1'-0"	1.0
27	1	4'-0"	3'-6"	14.0
28	1	1'-0"	1'-0"	1.0
29	1	1'-0"	2'-0"	2.0
30	1	1'-0"	3'-0"	3.0
31	1	2'-0"	1'-6"	3.0
32	3	1'-0"	1'-0"	1.0
33	1	1'-6"	1'-0"	1.5
34	1	1'-6"	1'-6"	2.3
35	1	1'-0"	1'-0"	1.0
36	1	2'-0"	1'-0"	2.0
37	1	0'-9"	4'-6"	3.4
38	1	0'-6"	1'-0"	0.5
39	1	25'-0"	2'-0"	50.0
40	1	2'-0"	14'-6"	29.0
41	1	2'-0"	6'-0"	12.0
42	1	1'-6"	1'-6"	2.3
43	1	6'-0"	1'-6"	9.0
44	1	1'-0"	1'-0"	1.0
45	1	6'-0"	1'-6"	9.0
46	1	2'-0"	1'-0"	2.0
47	1	1'-6"	1'-0"	1.5
48	1	1'-6"	1'-0"	1.5
49	1	1'-6"	1'-0"	1.5
50	4	10'-0"	18'-0"	180.0
51	1	1'-0"	1'-0"	1.0
TYPE 1 CNCT. REPAIR AREA = 244.6				
TYPE 2 CNCT. REPAIR AREA = 0.0				
TYPE 3 CNCT. REPAIR AREA = 1.0				
TYPE 4 CNCT. REPAIR AREA = 180.0				

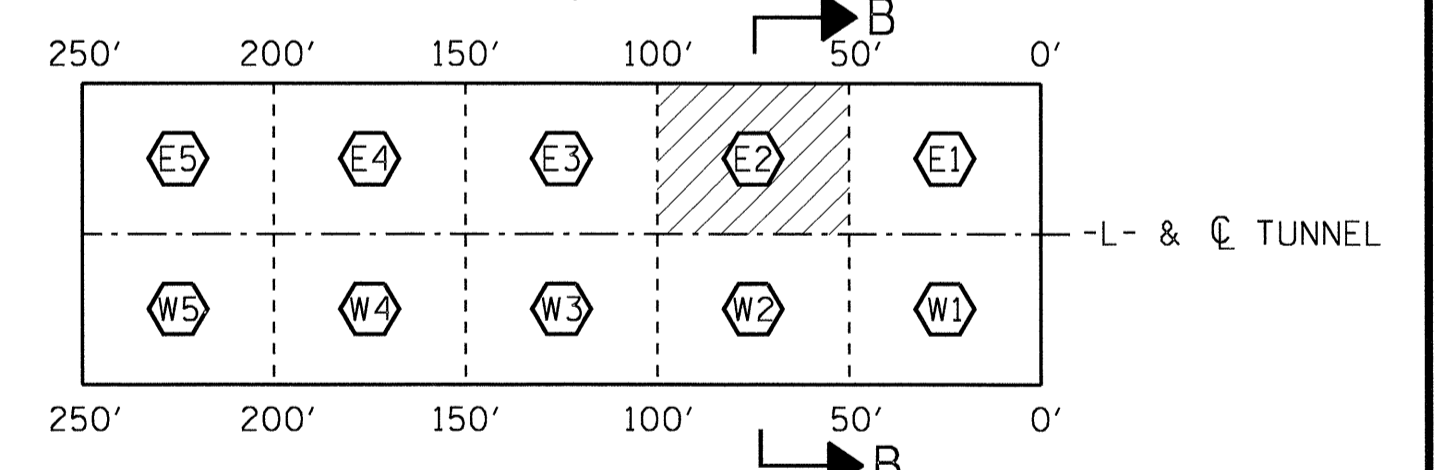
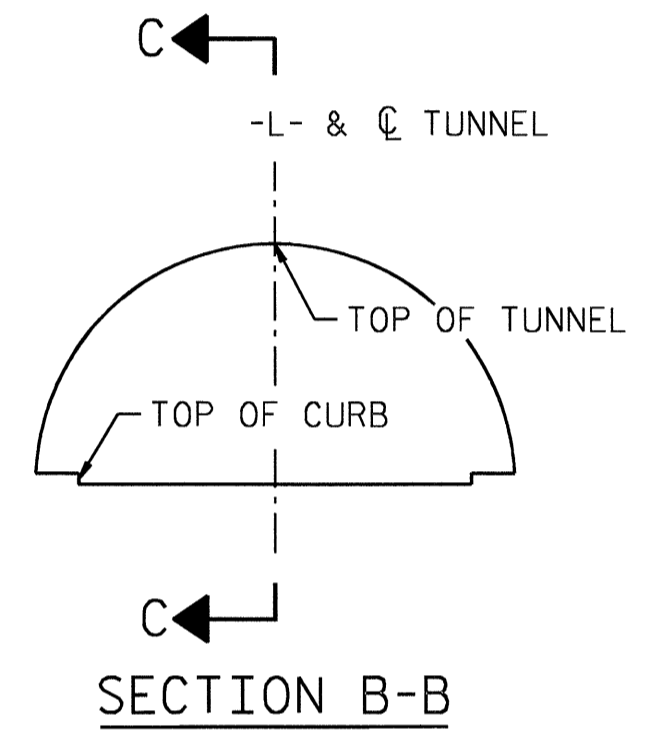

NOTES
 FOR SECTIONS V-V AND H-H, SEE VIEW A-A ON "SEGMENT LAYOUT & GRID REFERENCE DETAIL" SHEET.
 HATCHED REPAIR AREA CONSISTS OF DELAMINATING GROUT FINISH. SMALLER REPAIR AREAS INDICATED WITHIN THE HATCHED REPAIR AREA REPRESENT AREAS WHERE DAMAGE TO THE UNDERLYING TUNNEL CONCRETE HAS BEEN IDENTIFIED.

VIEW C-C: REPAIR SEGMENT E2 - TUNNEL SURFACE ELEVATION

DRAWN BY : M.J. SELLS DATE : 09/12
 CHECKED BY : J.B. TAYLOR DATE : 09/12



STATE OF NORTH CAROLINA
 DEPARTMENT OF TRANSPORTATION
 RALEIGH

TUNNEL REPAIR AREAS SEGMENT E2

REVISIONS						SHEET NO. 5-10
NO.	BY:	DATE:	NO.	BY:	DATE:	
1			3			TOTAL SHEETS 30
2			4			

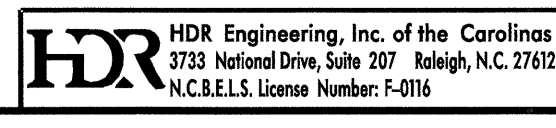

PLOT DRIVER: NCDOT.pdf_mono_eng_50.pht
 USER: msells DATE: 9/7/2012
 FILE: North Carolina Dept of Transportation\NCDOT_U-4014_McDowell\Structure\U4014_5D_RAC09_01.dgn

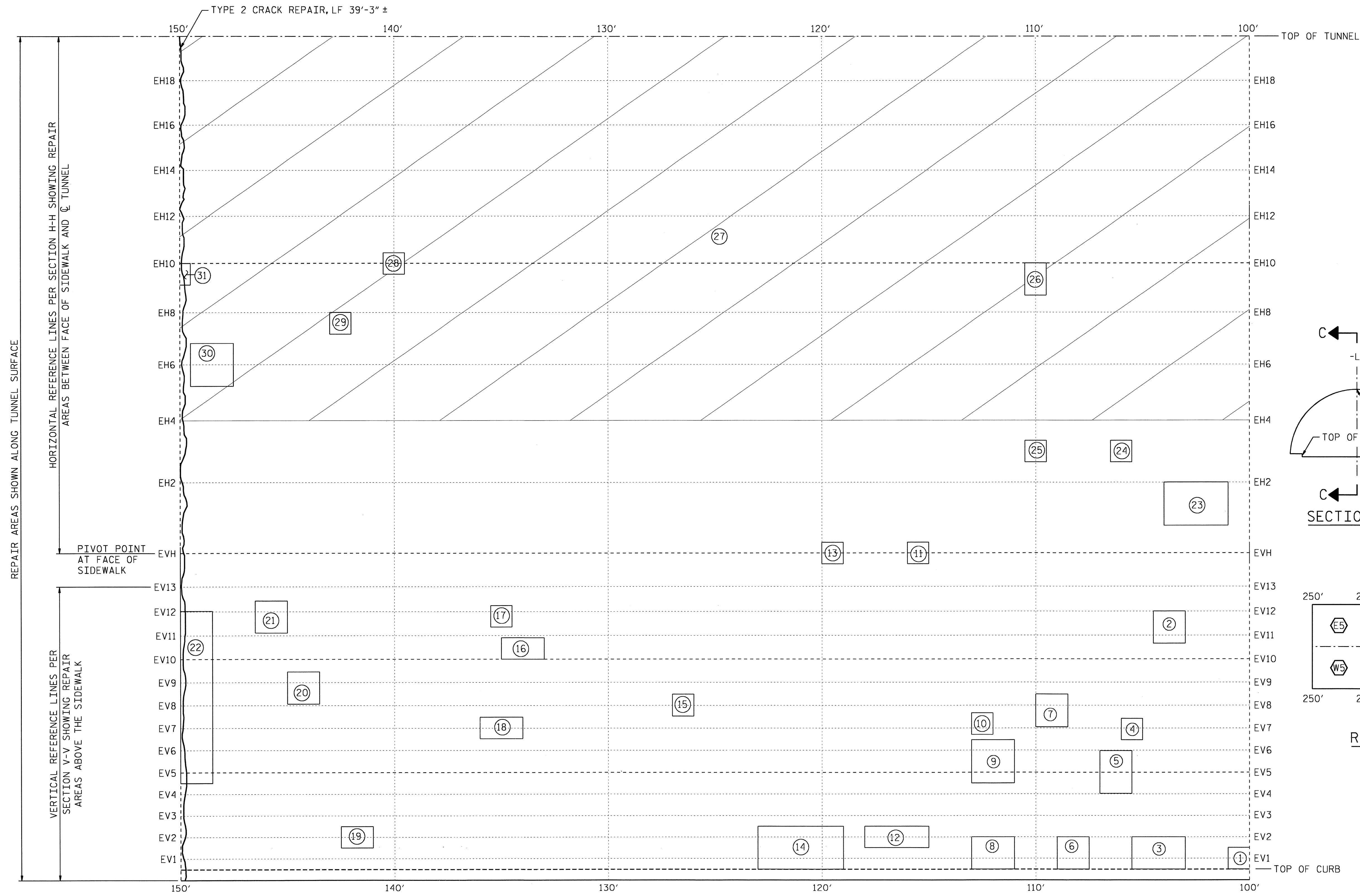

CONCRETE REPAIR AREAS				
NO.	TYPE	WIDTH	LENGTH	AREA (SF)
1	1	1'-0"	1'-0"	1.0
2	1	1'-6"	1'-6"	2.3
3	1	2'-6"	1'-6"	3.8
4	1	1'-0"	1'-0"	1.0
5	1	1'-6"	2'-0"	3.0
6	1	1'-6"	1'-6"	2.3
7	1	1'-6"	1'-6"	2.3
8	1	2'-0"	1'-6"	3.0
9	1	2'-0"	2'-0"	4.0
10	1	1'-0"	1'-0"	1.0
11	1	1'-0"	1'-0"	1.0
12	1	3'-0"	1'-0"	3.0
13	1	1'-0"	1'-0"	1.0
14	1	4'-0"	2'-0"	8.0
15	1	1'-0"	1'-0"	1.0
16	1	2'-0"	1'-0"	2.0
17	1	1'-0"	1'-0"	1.0
18	1	2'-0"	1'-0"	2.0
19	1	1'-6"	1'-0"	1.5
20	1	1'-6"	1'-6"	2.3
21	1	1'-6"	1'-6"	2.3
22	1	1'-6"	8'-0"	12.0
23	1	3'-0"	2'-0"	6.0
24	1	1'-0"	1'-0"	1.0
25	1	1'-0"	1'-0"	1.0
26	1	1'-0"	1'-6"	1.5
27	4	50'-0"	18'-0"	900.0
28	1	1'-0"	1'-0"	1.0
29	1	1'-0"	1'-0"	1.0
30	1	2'-0"	2'-0"	4.0
31	1	0'-6"	1'-0"	0.5
TYPE 1 CNCT. REPAIR AREA =				76.5
TYPE 2 CNCT. REPAIR AREA =				0.0
TYPE 3 CNCT. REPAIR AREA =				0.0
TYPE 4 CNCT. REPAIR AREA =				900.0

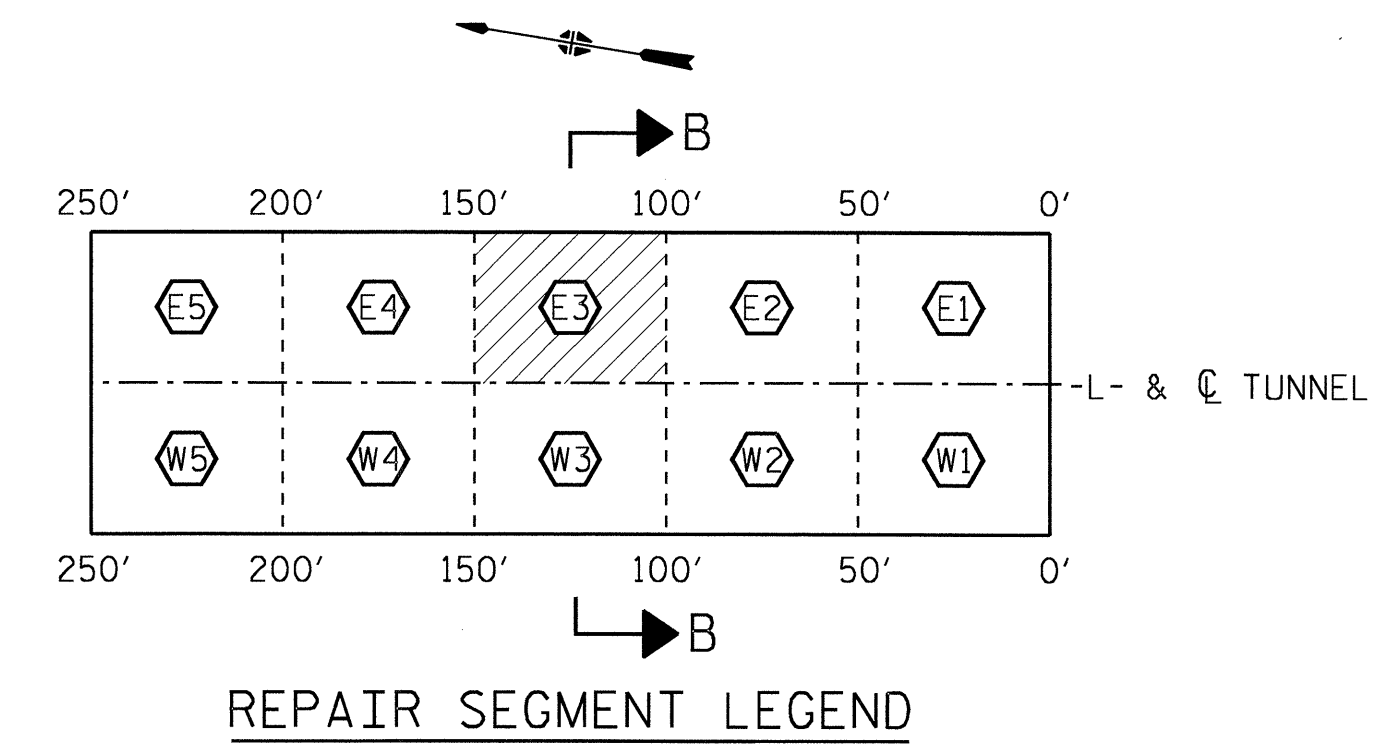
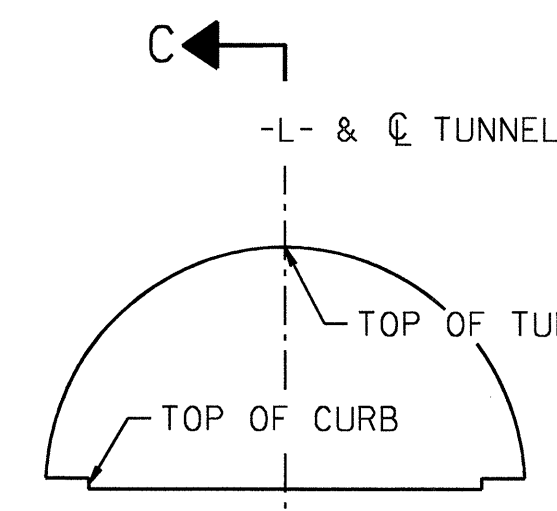

NOTES
 FOR SECTIONS V-V AND H-H, SEE VIEW A-A ON "SEGMENT LAYOUT & GRID REFERENCE DETAIL" SHEET.
 HATCHED REPAIR AREA CONSISTS OF DELAMINATING GROUT FINISH. SMALLER REPAIR AREAS INDICATED WITHIN THE HATCHED REPAIR AREA REPRESENT AREAS WHERE DAMAGE TO THE UNDERLYING TUNNEL CONCRETE HAS BEEN IDENTIFIED.

VIEW C-C: REPAIR SEGMENT E3 - TUNNEL SURFACE ELEVATION

PROJECT NO. U-4014
 BUNCOMBE COUNTY
 STATION: _____



STATE OF NORTH CAROLINA
 DEPARTMENT OF TRANSPORTATION
 RALEIGH
TUNNEL REPAIR AREAS SEGMENT E3

DRAWN BY: M.J. SELLS DATE: 09/12
 CHECKED BY: J.B. TAYLOR DATE: 09/12

REVISIONS					
NO.	BY:	DATE:	NO.	BY:	DATE:
1			3		
2			4		

SHEET NO. S-11
 TOTAL SHEETS 30

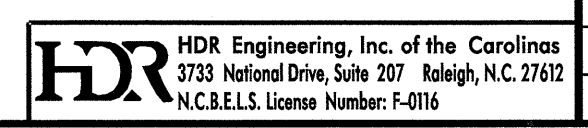

PLOT DRIVER: NCD0T.pdf_mono_eng-50.pit
 USER: msells
 FILE: North Carolina Dept. of Transportation\NCDOT_U_4014_McDowell\Structures\U4014_SD_RA10_01.dgn
 DATE: 9/7/2012
 TIME: 1:42:36 PM
 PENTABLE: MDT_pen.tbl

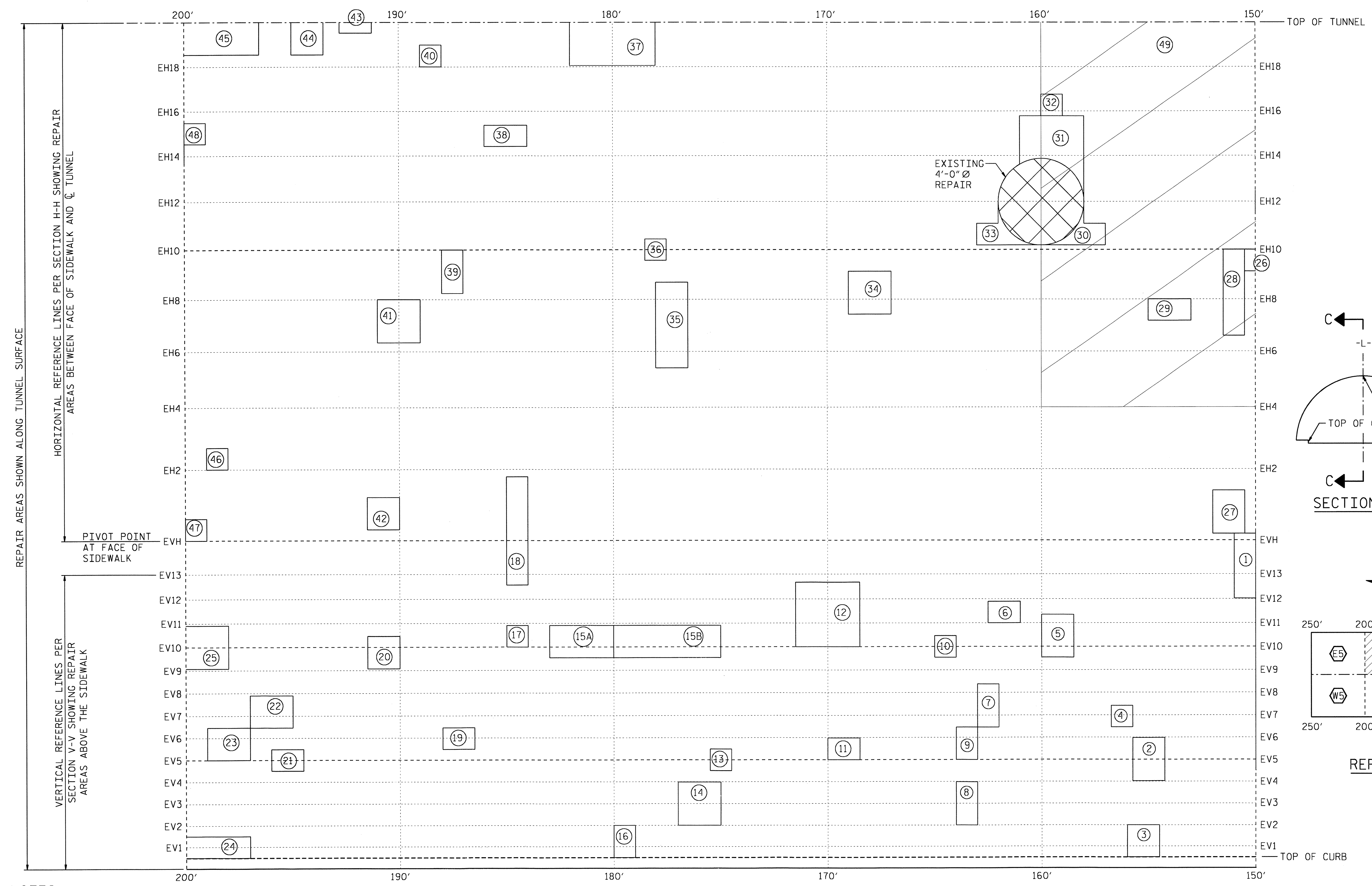

CONCRETE REPAIR AREAS				
NO.	TYPE	WIDTH	LENGTH	AREA (SF)
1	1	1'-0"	3'-0"	3.0
2	1	1'-6"	2'-0"	3.0
3	1	1'-6"	1'-6"	2.3
4	1	1'-0"	1'-0"	1.0
5	1	1'-6"	2'-0"	3.0
6	1	1'-6"	1'-0"	1.5
7	1	1'-0"	2'-0"	2.0
8	1	1'-0"	2'-0"	2.0
9	1	1'-0"	1'-6"	1.5
10	1	1'-0"	1'-0"	1.0
11	1	1'-6"	1'-0"	1.5
12	1	3'-0"	3'-0"	9.0
13	1	1'-0"	1'-0"	1.0
14	1	2'-0"	2'-0"	4.0
15A	1	3'-0"	1'-6"	4.5
15B	3	5'-0"	1'-6"	7.5
16	1	1'-0"	1'-6"	1.5
17	1	1'-0"	1'-0"	1.0
18	1	1'-0"	5'-0"	5.0
19	1	1'-6"	1'-0"	1.5
20	1	1'-6"	1'-6"	2.3
21	1	1'-6"	1'-0"	1.5
22	1	2'-0"	1'-6"	3.0
23	1	2'-0"	1'-6"	3.0
24	1	2'-6"	1'-0"	2.5
25	1	2'-0"	2'-0"	4.0
26	1	0'-6"	1'-0"	0.5
27	1	1'-6"	2'-0"	3.0
28	1	1'-0"	4'-0"	4.0
29	1	2'-0"	1'-0"	2.0
30	1	1'-0"	1'-0"	1.0
31	1	3'-0"	2'-0"	6.0
32	1	1'-0"	1'-0"	1.0
33	1	1'-0"	1'-0"	1.0
34	1	2'-0"	2'-0"	4.0
35	1	1'-6"	4'-0"	6.0
36	1	1'-0"	1'-0"	1.0
37	1	4'-0"	2'-0"	8.0
38	1	2'-0"	1'-0"	2.0
39	1	1'-0"	2'-0"	2.0
40	1	1'-0"	1'-0"	1.0
41	1	1'-0"	2'-0"	4.0
42	1	1'-6"	1'-6"	2.3
43	3	1'-6"	0'-6"	0.8
44	3	1'-6"	1'-6"	2.3
45	1	3'-6"	1'-6"	5.3
46	1	1'-0"	1'-0"	1.0
47	1	1'-0"	1'-0"	1.0
48	1	1'-0"	1'-0"	1.0
49	4	10'-0"	18'-0"	180.0

TYPE 1 CNCT. REPAIR AREA = 122.5
 TYPE 2 CNCT. REPAIR AREA = 0.0
 TYPE 3 CNCT. REPAIR AREA = 10.5
 TYPE 4 CNCT. REPAIR AREA = 180.0

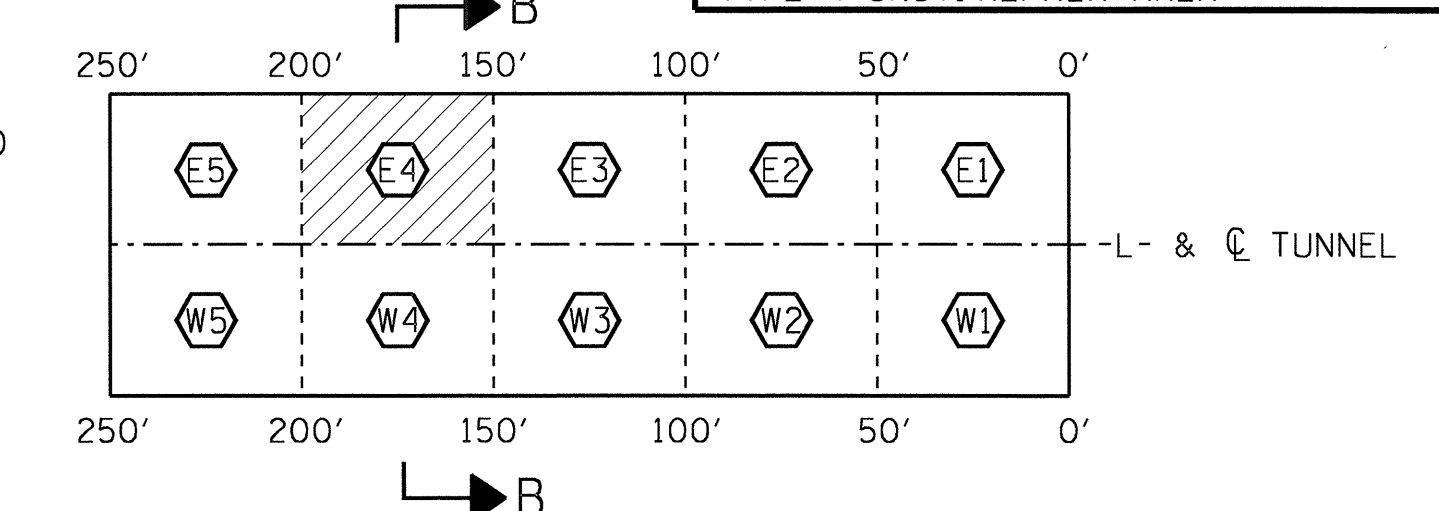
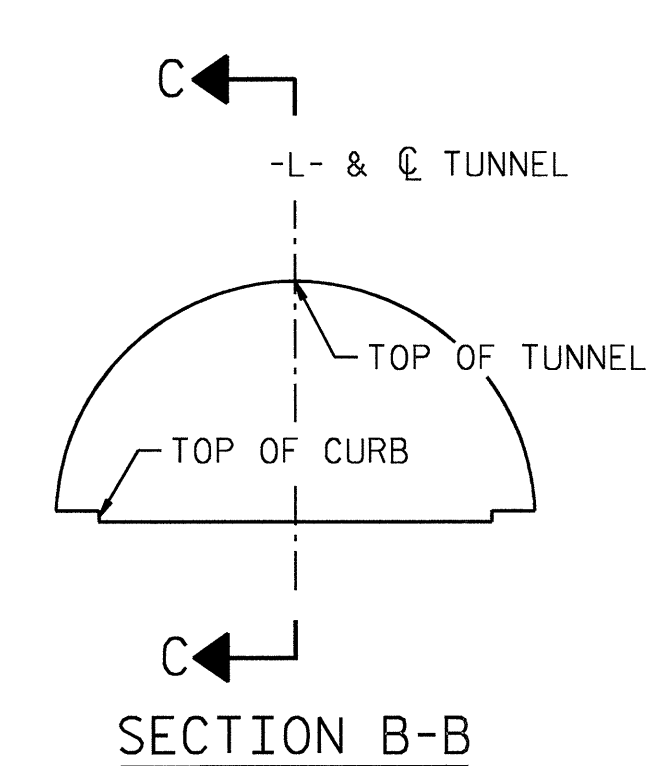

PROJECT NO. U-4014
 BUNCOMBE COUNTY
 STATION: _____

NOTES
 FOR SECTIONS V-V AND H-H, SEE VIEW A-A ON "SEGMENT LAYOUT & GRID REFERENCE DETAIL" SHEET.

HATCHED REPAIR AREA CONSISTS OF DELAMINATING GROUT FINISH. SMALLER REPAIR AREAS INDICATED WITHIN THE HATCHED REPAIR AREA REPRESENT AREAS WHERE DAMAGE TO THE UNDERLYING TUNNEL CONCRETE HAS BEEN IDENTIFIED.

VIEW C-C: REPAIR SEGMENT E4 - TUNNEL SURFACE ELEVATION

DRAWN BY: M.J. SELLS DATE: 09/12
 CHECKED BY: J.B. TAYLOR DATE: 09/12



STATE OF NORTH CAROLINA
 DEPARTMENT OF TRANSPORTATION
 RALEIGH
TUNNEL REPAIR AREAS SEGMENT E4

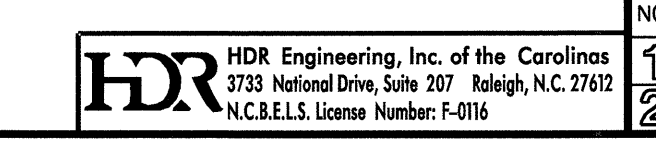

REVISIONS						SHEET NO. S-12
NO.	BY:	DATE:	NO.	BY:	DATE:	
1			3			TOTAL SHEETS 30
2			4			

PLOT DRIVER: NCDOT_pdf_mono_end_50.plt
 USER: msells
 FILE: North Carolina Dept. of Transportation\13.00_CAD\U-4014_S\Structures\U4014_S0_RA11.01.dgn
 PENTABLE: WDT_pen.tbl
 DATE: 9/7/2012
 TIME: 1:42:47 PM

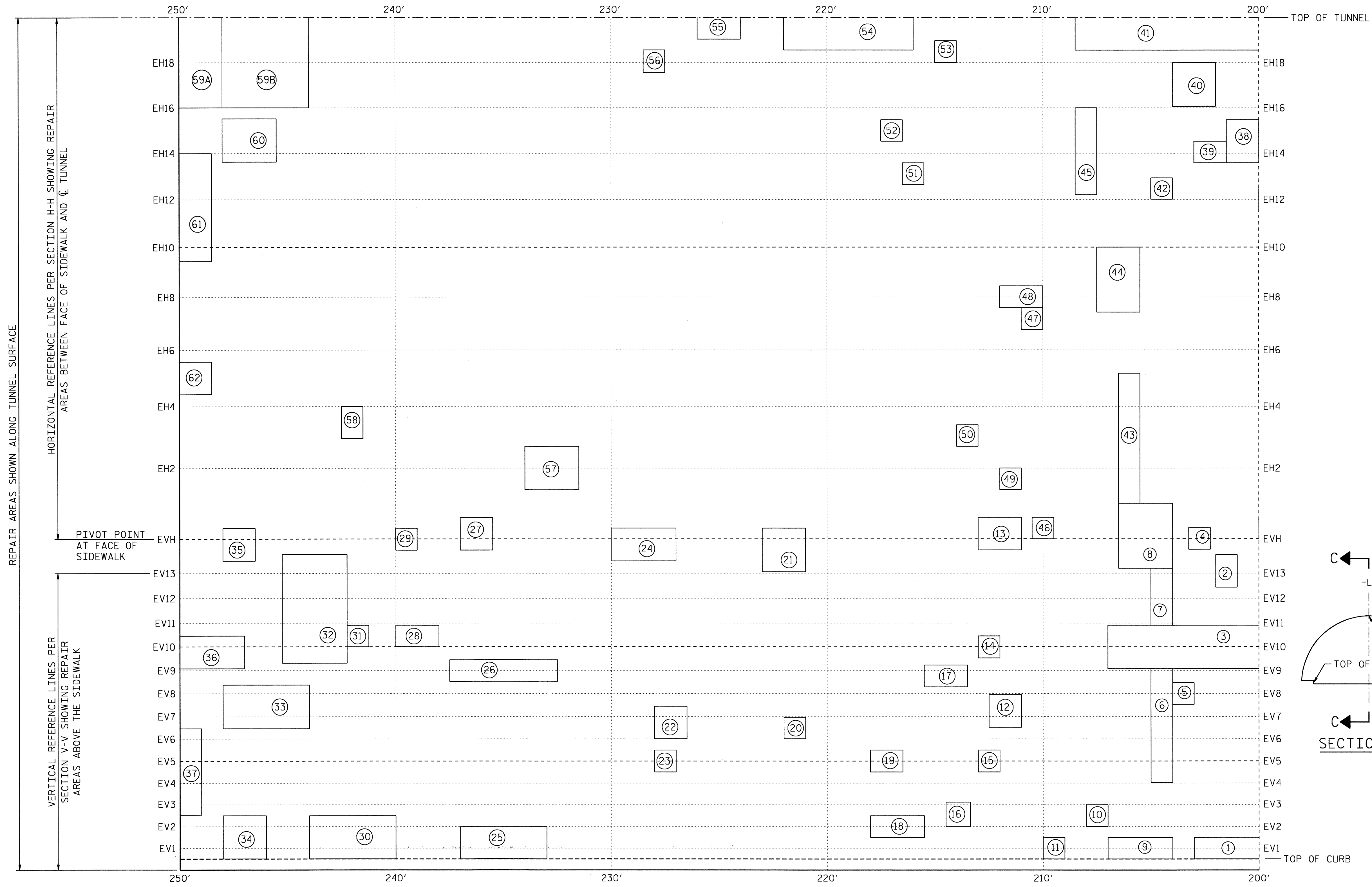

VIEW C-C: REPAIR SEGMENT E5 - TUNNEL SURFACE ELEVATION

NOTES
 FOR SECTIONS V-V AND H-H, SEE VIEW A-A ON "SEGMENT LAYOUT & GRID REFERENCE DETAIL" SHEET.

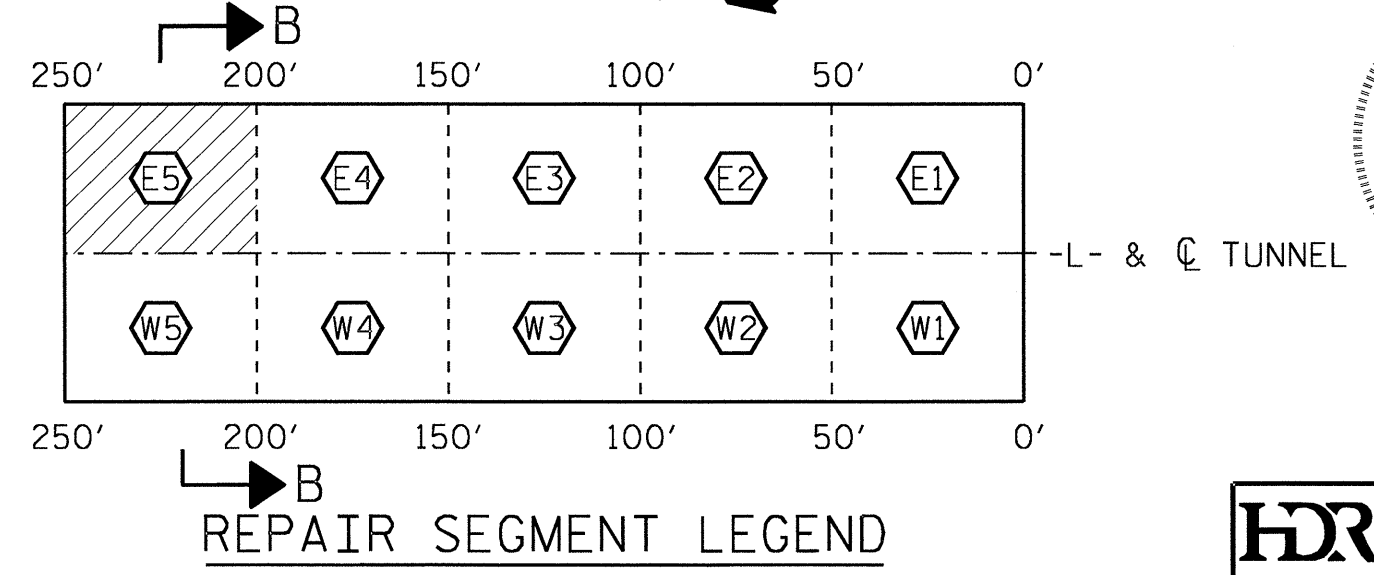

CONCRETE REPAIR AREAS				
NO.	TYPE	WIDTH	LENGTH	AREA (SF)
1	1	2'-6"	1'-0"	2.5
2	1	1'-0"	1'-6"	1.5
3	3	7'-0"	2'-0"	14.0
4	1	1'-0"	1'-0"	1.0
5	1	1'-0"	1'-0"	1.0
6	1	1'-0"	6'-6"	6.5
7	1	1'-0"	2'-6"	2.5
8	1	2'-6"	3'-0"	7.5
9	1	3'-0"	1'-0"	3.0
10	1	1'-0"	1'-0"	1.0
11	3	1'-0"	1'-0"	1.0
12	1	1'-6"	1'-6"	2.3
13	1	2'-0"	1'-6"	3.0
14	1	1'-0"	1'-0"	1.0
15	1	1'-0"	1'-0"	1.0
16	1	1'-0"	1'-0"	1.0
17	1	2'-0"	1'-0"	2.0
18	1	2'-6"	1'-0"	2.5
19	1	1'-6"	1'-0"	1.5
20	1	1'-0"	1'-0"	1.0
21	1	2'-0"	2'-0"	4.0
22	1	1'-6"	1'-6"	2.3
23	1	1'-0"	1'-0"	1.0
24	1	3'-0"	1'-6"	4.5
25	1	4'-0"	1'-6"	6.0
26	1	5'-0"	1'-0"	5.0
27	1	1'-6"	1'-6"	2.3
28	1	2'-0"	1'-0"	2.0
29	1	1'-0"	1'-0"	1.0
30	1	4'-0"	2'-0"	8.0
31	1	1'-0"	1'-0"	1.0
32	1	3'-0"	5'-0"	15.0
33	1	4'-0"	2'-0"	8.0
34	1	2'-0"	2'-0"	4.0
35	1	1'-6"	1'-6"	2.3
36	3	3'-0"	1'-6"	4.5
37	1	1'-0"	4'-0"	4.0
38	1	1'-6"	2'-0"	3.0
39	1	1'-6"	1'-0"	1.5
40	1	2'-0"	2'-0"	4.0
41	1	8'-6"	1'-6"	12.8
42	1	1'-0"	1'-0"	1.0
43	1	1'-0"	6'-0"	6.0
44	1	2'-0"	3'-0"	6.0
45	1	1'-0"	4'-0"	4.0
46	1	1'-0"	1'-0"	1.0
47	1	1'-0"	1'-0"	1.0
48	1	2'-0"	1'-0"	2.0
49	1	1'-0"	1'-0"	1.0
50	1	1'-0"	1'-0"	1.0
51	1	1'-0"	1'-0"	1.0
52	1	1'-0"	1'-0"	1.0
53	1	1'-0"	1'-0"	1.0
54	1	6'-0"	1'-6"	9.0
55	1	2'-0"	1'-0"	2.0
56	1	1'-0"	1'-0"	1.0
57	1	2'-6"	2'-0"	5.0
58	2	1'-0"	1'-6"	1.5
59A	3	2'-0"	4'-0"	8.0
59B	1	4'-0"	4'-0"	16.0
60	1	2'-6"	2'-0"	5.0
61	1	1'-6"	5'-0"	7.5
62	1	1'-6"	1'-6"	2.3

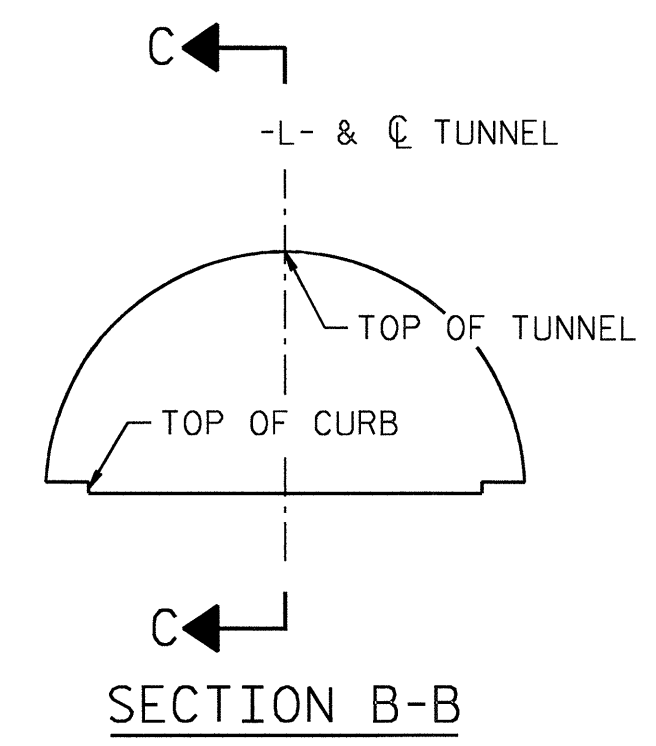

PROJECT NO. U-4014
 BUNCOMBE COUNTY
 STATION: _____

STATE OF NORTH CAROLINA
 DEPARTMENT OF TRANSPORTATION
 RALEIGH

TUNNEL REPAIR AREAS SEGMENT E5



REVISIONS					
NO.	BY:	DATE:	NO.	BY:	DATE:
1			3		
2			4		

DRAWN BY: M.J. SELLS DATE: 09/12
 CHECKED BY: J.B. TAYLOR DATE: 09/12

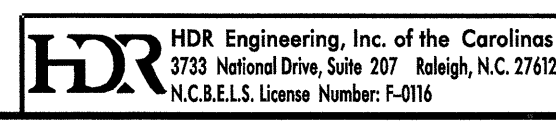

SHEET NO. S-13
 TOTAL SHEETS 30

PLOT DRIVER: NCDOT_pdf_mono_eng_50.plt
 USER: msells
 FILE: North Carolina Dept. of Transportation\NCDOT\U-4014_McDowell_Street\13.00_CAD\U-4014_Structures\U4014_SD_RA12.01.dgn
 PENTABLE: MDT_pen.tbl
 DATE: 9/7/2012
 TIME: 1:42:57 PM

CONCRETE REPAIR AREAS				
NO.	TYPE	WIDTH	LENGTH	AREA (SF)
1	3	1'-0"	9'-0"	9.0
2	3	1'-6"	1'-0"	1.5
3	2	VARIES	VARIES	52.5
4	1	VARIES	VARIES	142.0
5	3	10'-0"	1'-6"	15.0
6	3	10'-0"	VARIES	6.7
7	3	3'-0"	1'-0"	3.0
8	3	1'-0"	5'-11"	5.9
9	3	3'-0"	1'-6"	4.5
10	3	1'-0"	2'-0"	2.0
TYPE 1 CNCT. REPAIR AREA =				142.0
TYPE 2 CNCT. REPAIR AREA =				52.5
TYPE 3 CNCT. REPAIR AREA =				47.6

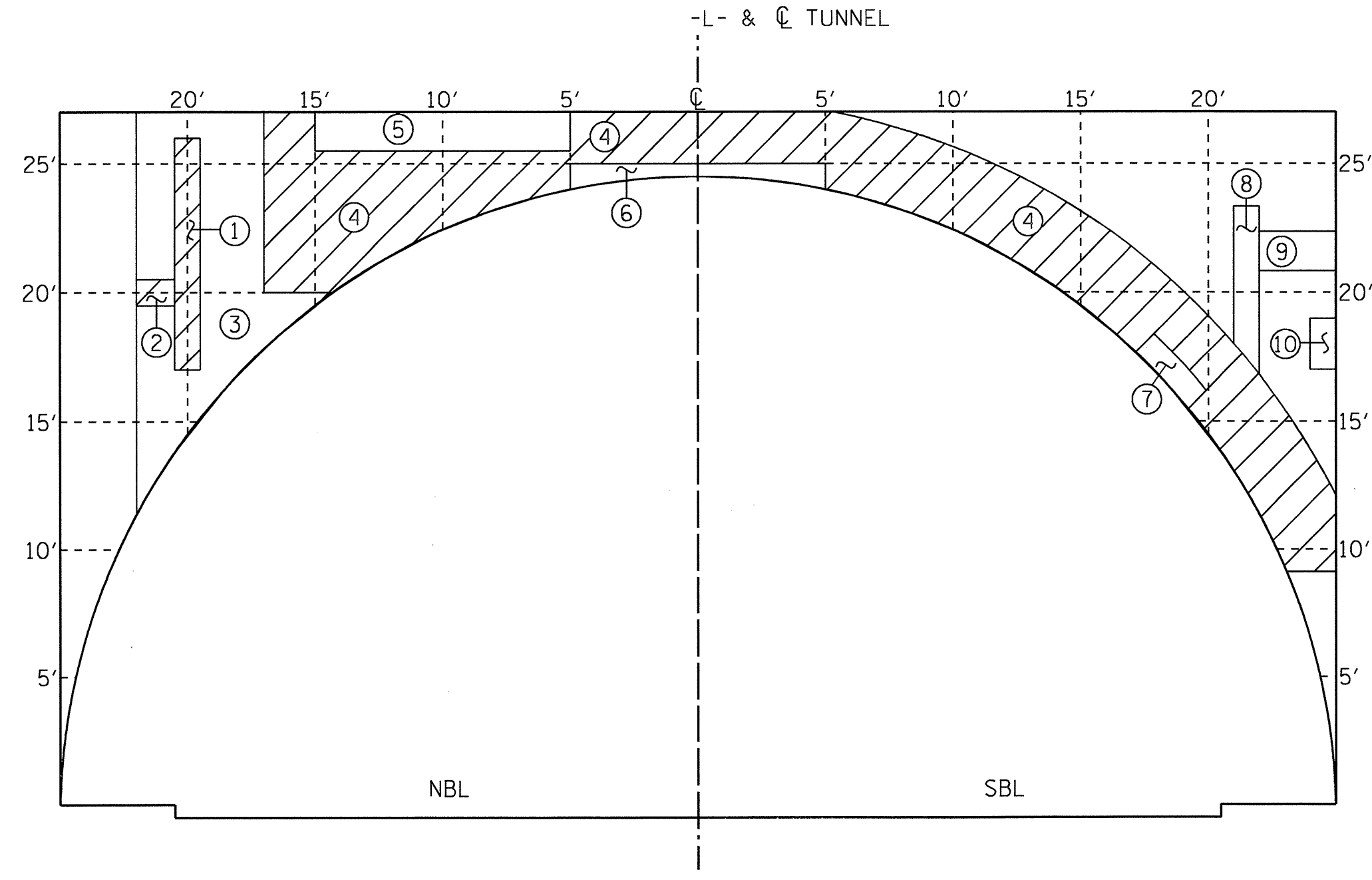

ELEVATION - NORTH PORTAL REPAIR AREAS

CONCRETE REPAIR AREAS				
NO.	TYPE	WIDTH	LENGTH	AREA (SF)
1	1	2'-6"	5'-0"	12.5
2	1	2'-0"	2'-0"	4.0
3	1	1'-6"	2'-6"	3.8
4	1	4'-6"	2'-0"	9.0
5	1	1'-0"	1'-0"	1.0
6	1	1'-0"	1'-0"	1.0
7	1	1'-0"	1'-0"	1.0
8	3	1'-0"	2'-0"	2.0
9	3	1'-0"	3'-0"	3.0
10	3	2'-0"	1'-0"	2.0
11	1	1'-0"	1'-0"	1.0
12	3	2'-0"	1'-0"	2.0
13	3	1'-0"	1'-0"	1.0
14	3	1'-6"	2'-0"	3.0
15	3	3'-0"	3'-0"	9.0
16	3	4'-0"	1'-0"	4.0
17	3	2'-6"	2'-6"	6.3
18A	3	2'-0"	2'-0"	4.0
18B	1	2'-0"	2'-0"	4.0
19	2	1'-0"	2'-0"	2.0
20	2	2'-0"	2'-6"	5.0
21	2	1'-0"	4'-0"	4.0
TYPE 1 CNCT. REPAIR AREA =				37.3
TYPE 2 CNCT. REPAIR AREA =				11.0
TYPE 3 CNCT. REPAIR AREA =				36.3

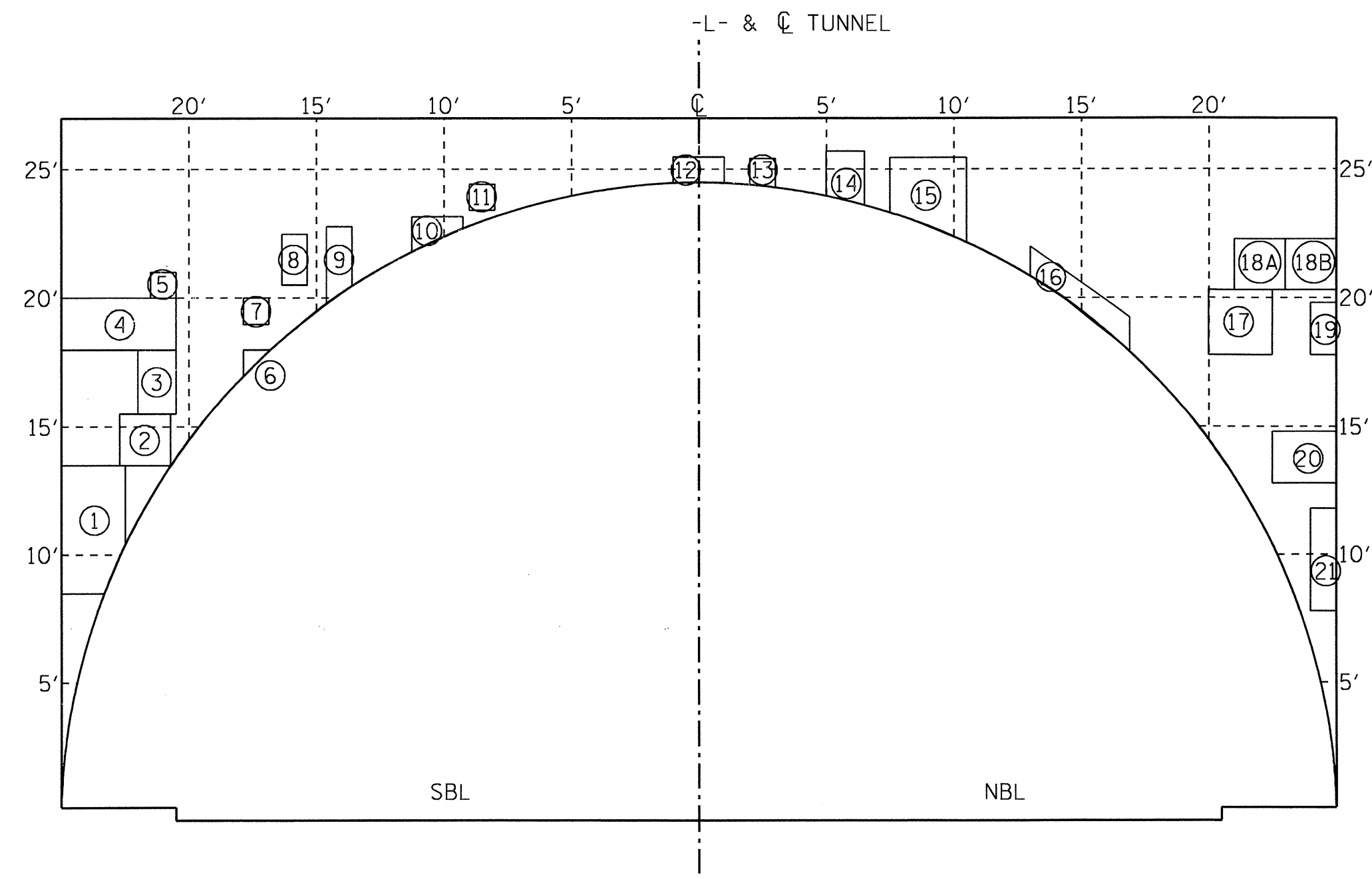

ELEVATION - SOUTH PORTAL REPAIR AREAS

PROJECT NO. U-4014
 BUNCOMBE COUNTY
 STATION: _____

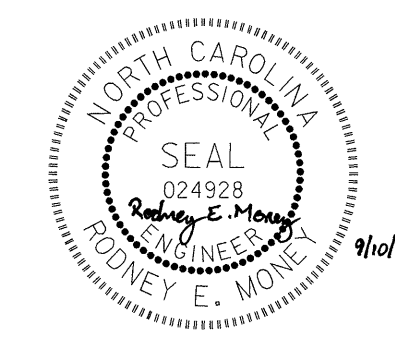

STATE OF NORTH CAROLINA
 DEPARTMENT OF TRANSPORTATION
 RALEIGH
 PORTAL REPAIR AREAS
 NORTH & SOUTH
 ENTRANCES

DRAWN BY: M.J. SELLS DATE: 05/11
 CHECKED BY: J.B. TAYLOR DATE: 05/11

HDR HDR Engineering, Inc. of the Carolinas
 3733 National Drive, Suite 207 Raleigh, N.C. 27612
 N.C.E.L.S. License Number: F-0116

REVISIONS						SHEET NO. 5-14 TOTAL SHEETS 30
NO.	BY:	DATE:	NO.	BY:	DATE:	
1			3			
2			4			

CONCRETE REPAIR AREAS				
NO.	TYPE	WIDTH	LENGTH	AREA (SF)
1	2	1'-0"	1'-0"	1.0
2	2	2'-0"	12'-0"	24.0
3	1	1'-0"	1'-0"	1.0
4	1	3'-0"	1'-6"	4.5
5	1	2'-0"	2'-0"	4.0
6	2	2'-0"	4'-0"	8.0
7	3	1'-6"	1'-6"	2.3
8	1	1'-0"	1'-0"	1.0
9	1	2'-0"	1'-0"	2.0
10	1	1'-0"	1'-0"	1.0
11	1	1'-0"	1'-0"	1.0
12	1	2'-0"	2'-0"	4.0
13	1	2'-0"	2'-0"	4.0
14	1	1'-0"	1'-0"	1.0
15	2	1'-0"	1'-0"	1.0
16	2	1'-0"	1'-0"	1.0
17	3	3'-0"	2'-0"	6.0
18	3	1'-0"	1'-0"	1.0
19	3	2'-0"	2'-0"	4.0
20	3	1'-0"	1'-0"	1.0
21	2	1'-0"	1'-0"	1.0
22	1	2'-0"	2'-0"	4.0
23	1	1'-6"	1'-6"	2.3
24	1	1'-6"	1'-6"	2.3
25	1	1'-0"	1'-0"	1.0
26	3	4'-6"	3'-6"	15.8
27	1	1'-0"	1'-0"	1.0
28	1	1'-0"	1'-0"	1.0
29	1	1'-0"	1'-0"	1.0
30	1	2'-6"	1'-6"	3.8
31	1	7'-6"	2'-0"	15.0
32	3	1'-0"	1'-0"	1.0
33	1	2'-6"	2'-0"	5.0
34	1	1'-0"	1'-0"	1.0
35	3	2'-6"	2'-0"	5.0
36	1	2'-6"	2'-0"	5.0
37	3	2'-6"	4'-0"	10.0
38	1	1'-0"	1'-0"	1.0
39	1	2'-6"	2'-0"	5.0
40	1	1'-0"	2'-0"	2.0
TYPE 1 CNCT. REPAIR AREA =		73.8		
TYPE 2 CNCT. REPAIR AREA =		36.0		
TYPE 3 CNCT. REPAIR AREA =		46.0		

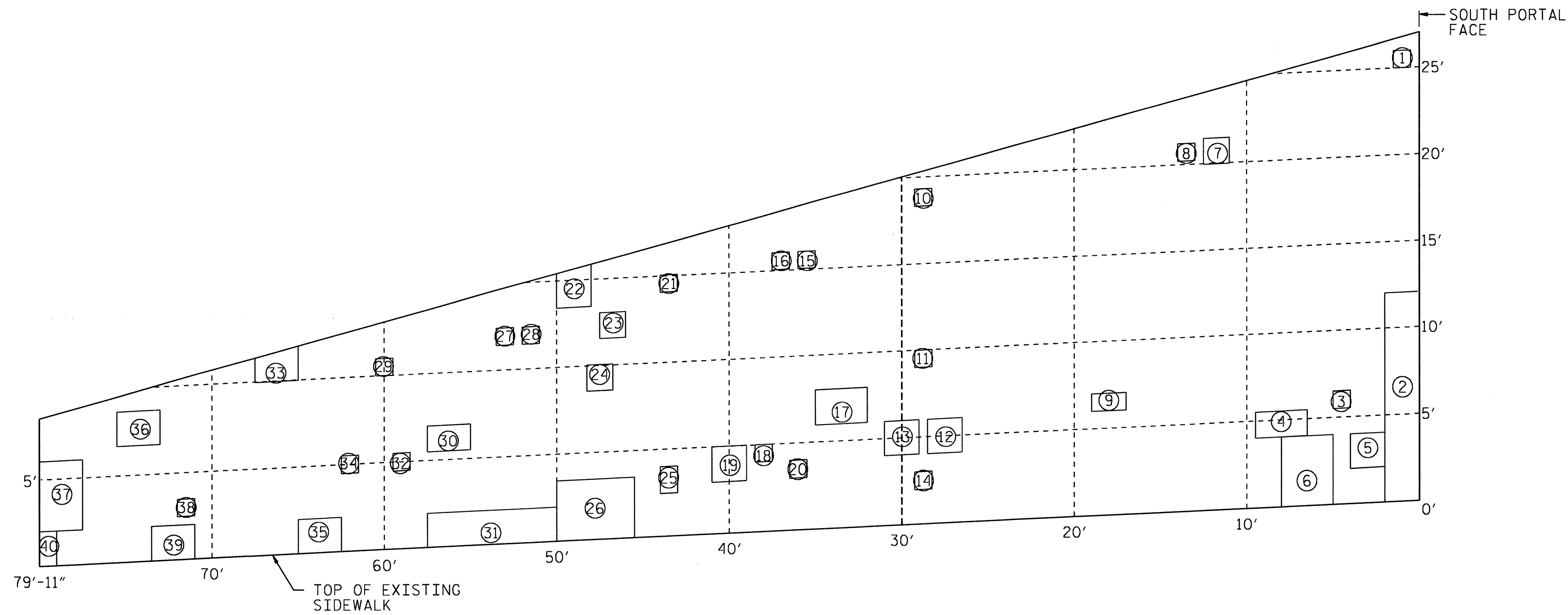

ELEVATION - SOUTHWEST WINGWALL REPAIRS AREAS

PROJECT NO. U-4014
BUNCOMBE COUNTY
 STATION: _____



STATE OF NORTH CAROLINA
 DEPARTMENT OF TRANSPORTATION
 RALEIGH

**SOUTHWEST WINGWALL
 REPAIR AREAS**

REVISIONS						SHEET NO. S-15
NO.	BY:	DATE:	NO.	BY:	DATE:	
1			3			TOTAL SHEETS 30
2			4			

DRAWN BY : M.J. SELLS DATE : 05/11
 CHECKED BY : J.B. TAYLOR DATE : 05/11



PLOT DRIVER: NCDOT... PENITABLE: MDT_pen.tbl
 USER: msells DATE: 9/7/2012 TIME: 14:31:17 PM
 FILE: North Carolina\Dept_of_Transportation\NCDOT_U_4014_McDowell_Street\13.00_CAD\U-4014_Structures\U4014_SD_RA14_01.dgn

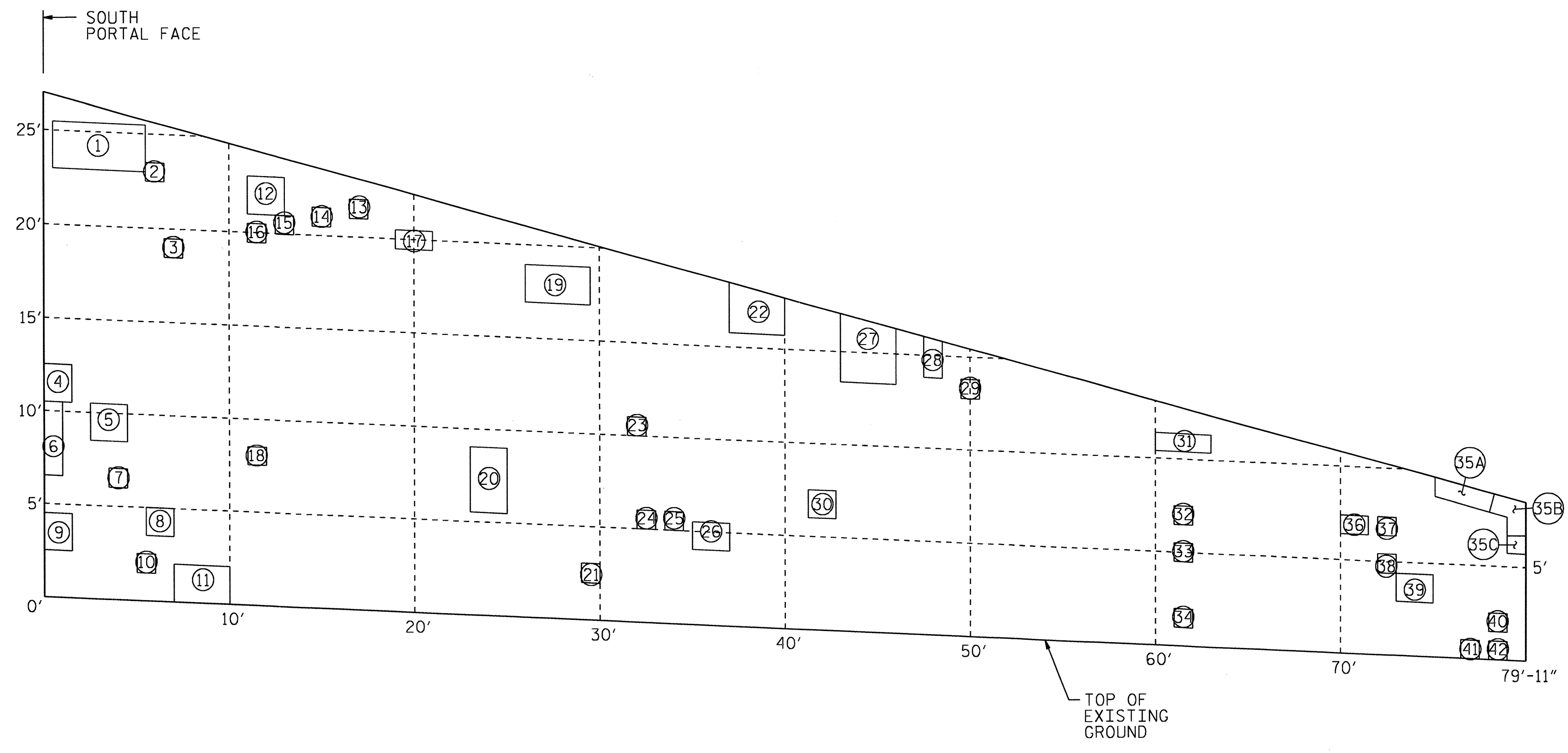

ELEVATION - SOUTHEAST WINGWALL REPAIR AREAS

CONCRETE REPAIR AREAS				
NO.	TYPE	WIDTH	LENGTH	AREA (SF)
1	2	5'-0"	2'-6"	12.5
2	2	1'-0"	1'-0"	1.0
3	2	1'-0"	1'-0"	1.0
4	3	1'-6"	2'-0"	3.0
5	3	2'-0"	2'-0"	4.0
6	3	1'-0"	4'-0"	4.0
7	2	1'-0"	1'-0"	1.0
8	2	1'-6"	1'-6"	2.3
9	2	1'-6"	2'-0"	3.0
10	2	1'-0"	1'-0"	1.0
11	2	3'-0"	2'-0"	6.0
12	3	2'-0"	2'-0"	4.0
13	2	1'-0"	1'-0"	1.0
14	2	1'-0"	1'-0"	1.0
15	2	1'-0"	1'-0"	1.0
16	2	1'-0"	1'-0"	1.0
17	2	2'-0"	1'-0"	2.0
18	2	1'-0"	1'-0"	1.0
19	2	3'-6"	2'-0"	7.0
20	2	2'-0"	3'-6"	7.0
21	2	1'-0"	1'-0"	1.0
22	2	2'-0"	3'-0"	6.0
23	2	1'-0"	1'-0"	1.0
24	1	1'-0"	1'-0"	1.0
25	1	1'-0"	1'-0"	1.0
26	1	2'-0"	1'-6"	3.0
27	2	3'-0"	3'-0"	9.0
28	1	1'-0"	2'-0"	2.0
29	1	1'-0"	1'-0"	1.0
30	1	1'-6"	1'-6"	2.3
31	3	3'-0"	1'-0"	3.0
32	2	1'-0"	1'-0"	1.0
33	3	1'-0"	1'-0"	1.0
34	2	1'-0"	1'-0"	1.0
35A	1	3'-0"	1'-0"	3.0
35B	2	2'-0"	1'-0"	2.0
35C	1	1'-0"	1'-0"	1.0
36	1	1'-6"	1'-0"	1.5
37	1	1'-0"	1'-0"	1.0
38	1	1'-0"	1'-0"	1.0
39	1	2'-0"	1'-6"	3.0
40	2	1'-0"	1'-0"	1.0
41	2	1'-0"	1'-0"	1.0
42	2	1'-0"	1'-0"	1.0
TYPE 1 CNCT. REPAIR AREA =				20.8
TYPE 2 CNCT. REPAIR AREA =				72.8
TYPE 3 CNCT. REPAIR AREA =				19.0

PROJECT NO. U-4014
 BUNCOMBE COUNTY
 STATION:



STATE OF NORTH CAROLINA
 DEPARTMENT OF TRANSPORTATION
 RALEIGH

SOUTHEAST WINGWALL
 REPAIR AREAS

REVISIONS					
NO.	BY:	DATE:	NO.	BY:	DATE:
1			3		
2			4		

SHEET NO. S-16
 TOTAL SHEETS 30

DRAWN BY: M.J. SELLS DATE: 05/11
 CHECKED BY: J.B. TAYLOR DATE: 05/11

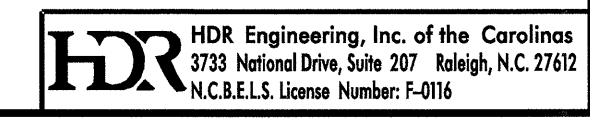

PLOT DRIVER: NCDOT_pdf_mono_eng_50.plt
 USER: msells
 FILE: North Carolina Dept. of Transportation\NCDOT_U-4014_McDowell_Street\13.00_CAD\U-4014_Structures\U4014_SD_RA15_01.dgn
 DATE: 9/7/2012
 TIME: 1:43:27 PM

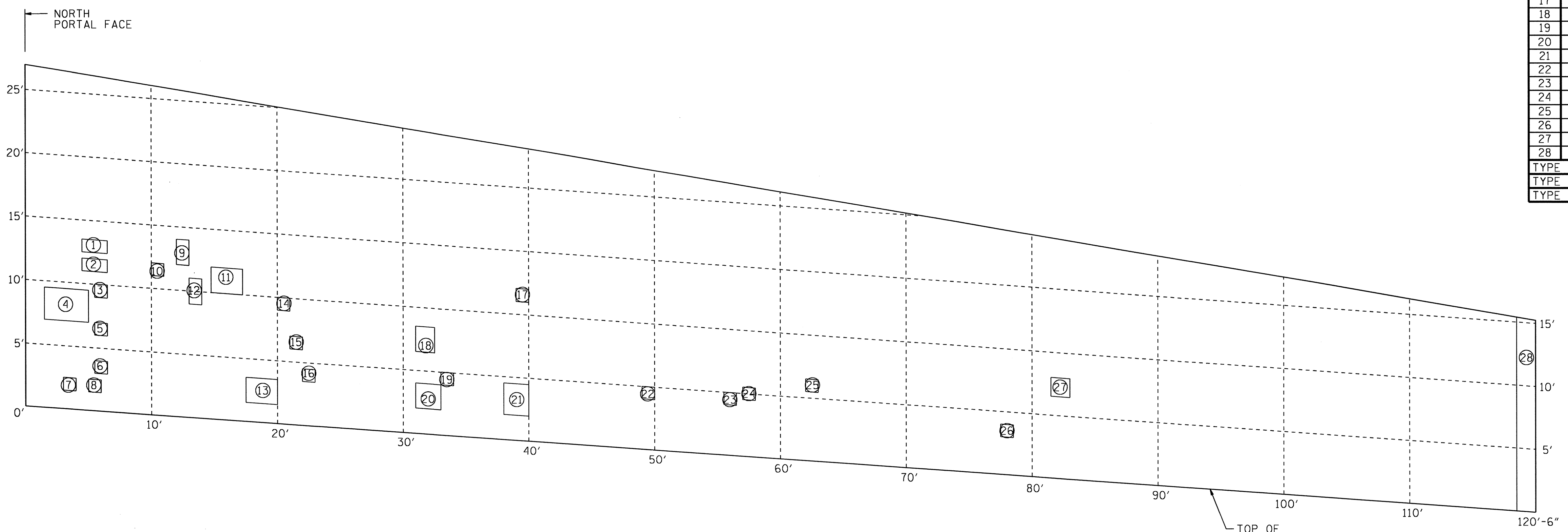

ELEVATION - NORTHWEST WINGWALL REPAIR AREAS

CONCRETE REPAIR AREAS				
NO.	TYPE	WIDTH	LENGTH	AREA (SF)
1	2	2'-0"	1'-0"	2.0
2	2	2'-0"	1'-0"	2.0
3	1	1'-0"	1'-0"	1.0
4	3	3'-6"	2'-6"	8.8
5	2	1'-0"	1'-0"	1.0
6	2	1'-0"	1'-0"	1.0
7	3	1'-0"	1'-0"	1.0
8	3	1'-0"	1'-0"	1.0
9	2	1'-0"	2'-0"	2.0
10	2	1'-0"	1'-0"	1.0
11	2	2'-6"	2'-0"	5.0
12	2	1'-0"	2'-0"	2.0
13	2	2'-6"	2'-0"	5.0
14	1	1'-0"	1'-0"	1.0
15	1	1'-0"	1'-0"	1.0
16	1	1'-0"	1'-0"	1.0
17	2	1'-0"	1'-0"	1.0
18	3	1'-6"	2'-0"	3.0
19	1	1'-0"	1'-0"	1.0
20	3	2'-0"	2'-0"	4.0
21	2	2'-0"	2'-6"	5.0
22	2	1'-0"	1'-0"	1.0
23	2	1'-0"	1'-0"	1.0
24	2	1'-0"	1'-0"	1.0
25	2	1'-0"	1'-0"	1.0
26	2	1'-0"	1'-0"	1.0
27	2	1'-6"	1'-6"	2.3
28	1	1'-6"	15'-0"	22.5
TYPE 1 CNCT. REPAIR AREA =				27.5
TYPE 2 CNCT. REPAIR AREA =				34.3
TYPE 3 CNCT. REPAIR AREA =				17.8

PROJECT NO. U-4014
BUNCOMBE COUNTY
 STATION: _____



STATE OF NORTH CAROLINA
 DEPARTMENT OF TRANSPORTATION
 RALEIGH
 NORTHWEST WINGWALL
 REPAIR AREAS

DRAWN BY : M.J. SELLS DATE : 05/11
 CHECKED BY : J.B. TAYLOR DATE : 05/11

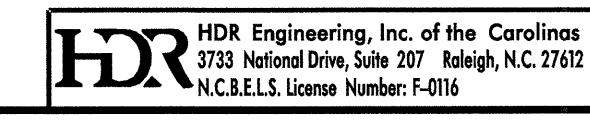

REVISIONS						SHEET NO. S-17
NO.	BY:	DATE:	NO.	BY:	DATE:	
1			3			TOTAL SHEETS 30
2			4			

CONCRETE REPAIR AREAS				
NO.	TYPE	WIDTH	LENGTH	AREA (SF)
1	3	1'-6"	1'-6"	2.3
2	3	1'-0"	1'-0"	1.0
3	1	1'-0"	1'-0"	1.0
4	1	1'-0"	1'-0"	1.0
5	1	1'-0"	3'-6"	3.5
6	3	2'-6"	2'-0"	5.0
7	3	1'-0"	1'-0"	1.0
8	3	1'-0"	1'-0"	1.0
9	1	1'-0"	1'-0"	1.0
10	3	1'-0"	1'-0"	1.0
11	3	1'-0"	1'-0"	1.0
12	1	1'-0"	1'-0"	1.0
13	1	1'-0"	1'-0"	1.0
14	1	1'-0"	1'-0"	1.0
15	1	1'-0"	2'-0"	2.0
16	1	2'-0"	1'-0"	2.0
17	1	1'-0"	1'-0"	1.0
18	1	1'-0"	1'-0"	1.0
19	1	1'-0"	1'-0"	1.0
20	1	1'-0"	1'-0"	1.0
21	1	1'-6"	1'-0"	1.5
22	1	1'-0"	1'-0"	1.0
23	3	1'-6"	1'-6"	2.3
24	1	1'-0"	1'-0"	1.0
25	3	1'-0"	1'-0"	1.0
26	1	1'-0"	2'-0"	2.0
27	1	2'-0"	1'-0"	2.0
28	1	2'-0"	1'-6"	3.0
29	1	2'-0"	1'-0"	2.0
30	1	1'-0"	1'-0"	1.0
31	1	1'-0"	1'-0"	1.0
32	1	1'-0"	1'-6"	1.5
33	1	1'-0"	1'-0"	1.0
34	1	2'-0"	2'-0"	4.0
35	1	1'-0"	1'-6"	1.5
36	1	2'-0"	1'-0"	2.0
37	3	1'-0"	11'-0"	11.0
TYPE 1 CNCT. REPAIR AREA = 42.0				
TYPE 2 CNCT. REPAIR AREA = 0.0				
TYPE 3 CNCT. REPAIR AREA = 26.5				

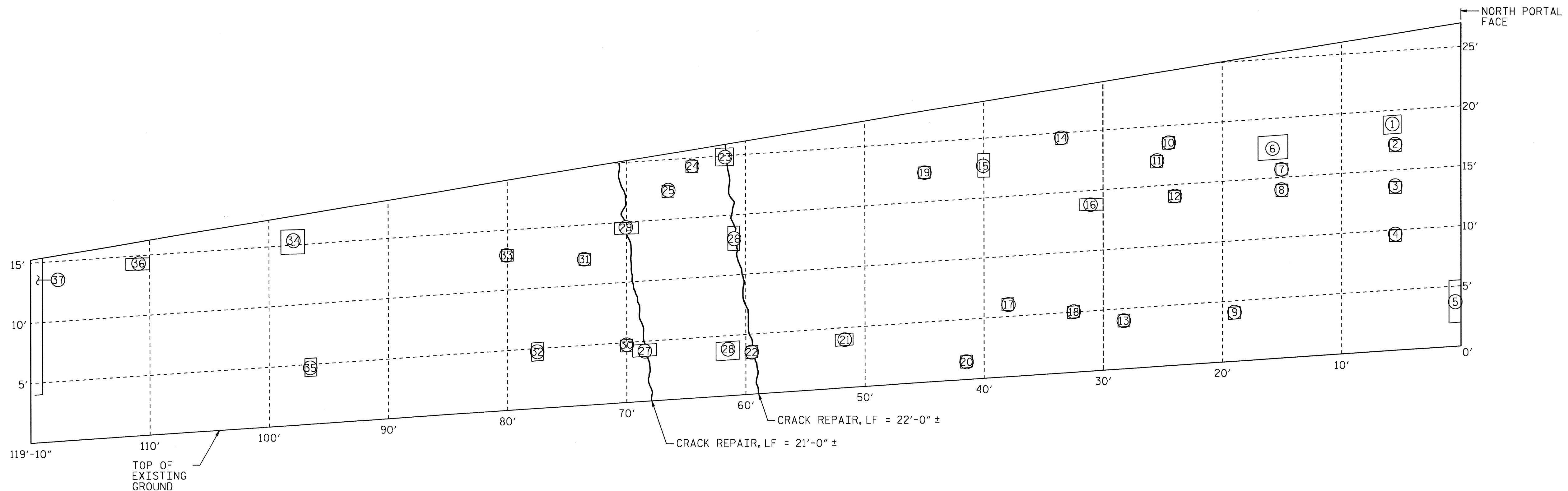

ELEVATION - NORTHEAST WINGWALL REPAIR AREAS

PROJECT NO. U-4014
BUNCOMBE COUNTY
STATION: _____

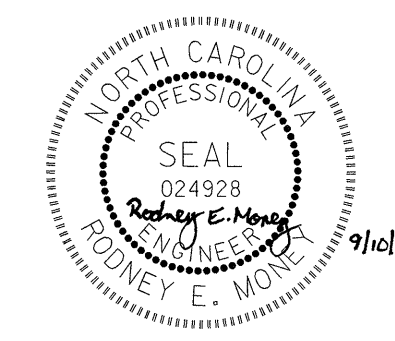

STATE OF NORTH CAROLINA
DEPARTMENT OF TRANSPORTATION
RALEIGH
NORTHEAST WINGWALL
REPAIR AREAS

REVISIONS						SHEET NO. S-18 TOTAL SHEETS 30
NO.	BY:	DATE:	NO.	BY:	DATE:	
1			3			
2			4			

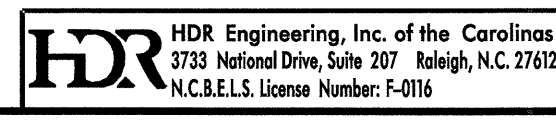

DRAWN BY : M.J. SELLS DATE : 05/11
CHECKED BY : J.B. TAYLOR DATE : 05/11

PLOT DRIVER: NCDOT_pdf_mono_eng_50.plt
USER: msells
FILE: North Carolina Dept. of Transportation\1300_CAD\U-4014\Structures\U4014_SD_RA16.01.dgn
PENTABLE: MDT_pen.tbl
DATE: 9/7/2012
TIME: 1:43:36 PM

NOTES

FOR NOTES, SEE "GENERAL NOTES AND TOTAL BILL OF MATERIAL".

FOR DETAIL 1 AND VIEW D-D (PORTAL-TO-WINGWALL TRANSITION SECTION DETAILS), SEE "AESTHETIC TREATMENTS (2 OF 6)".

FOR PORTAL COPING DETAILS, SEE "AESTHETIC TREATMENTS (5 OF 6)".

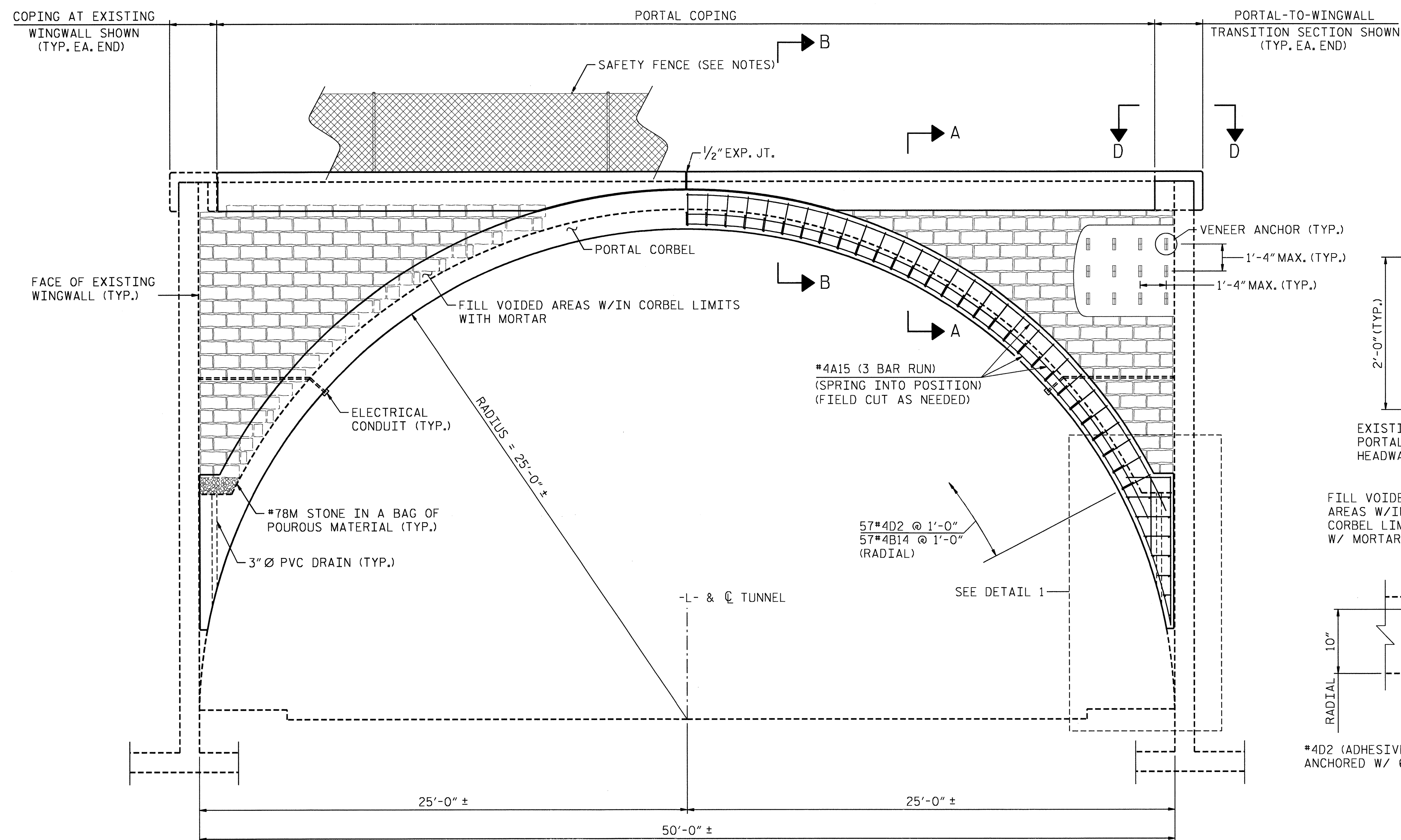

PORTAL ELEVATION

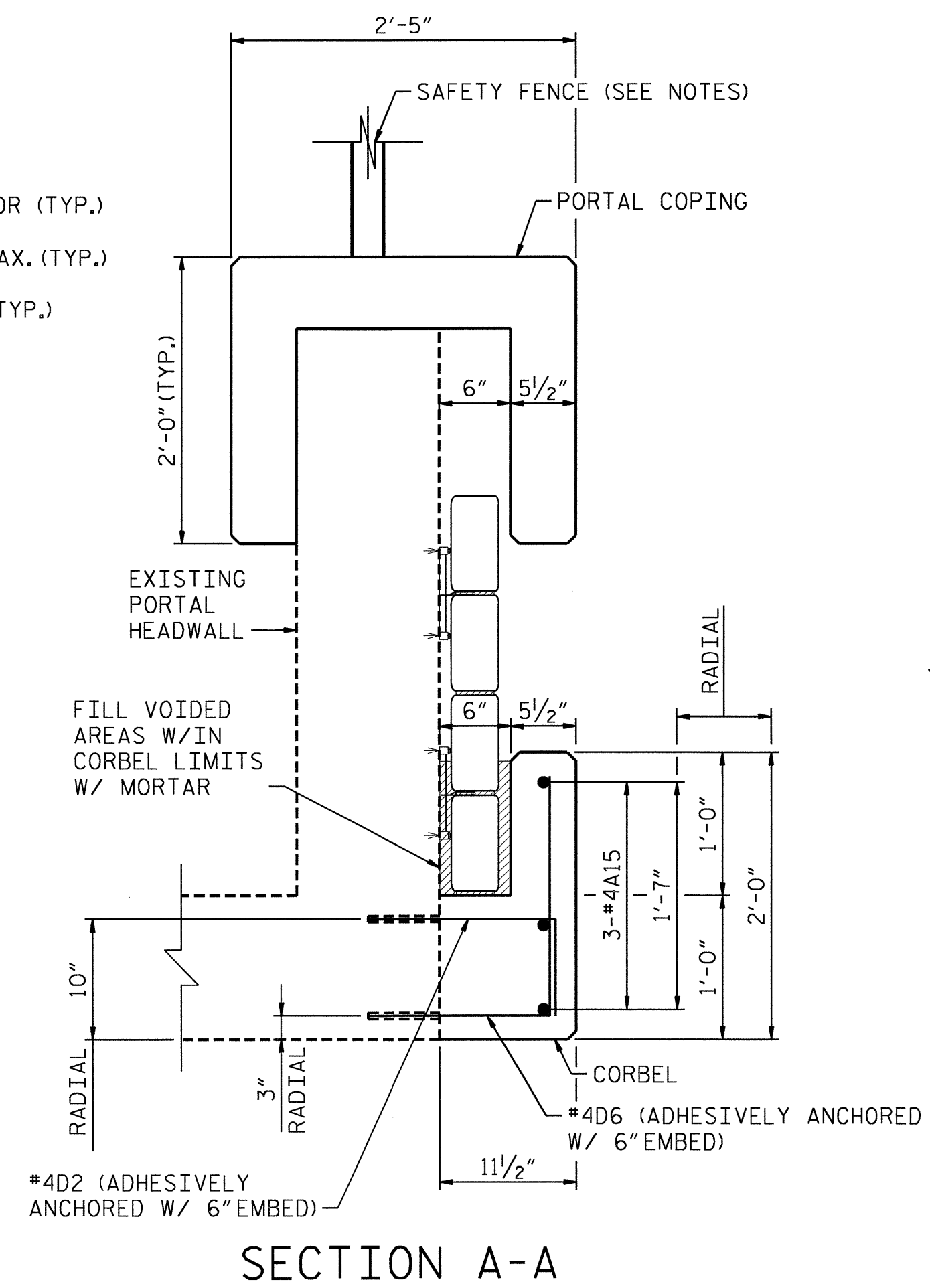

SECTION A-A

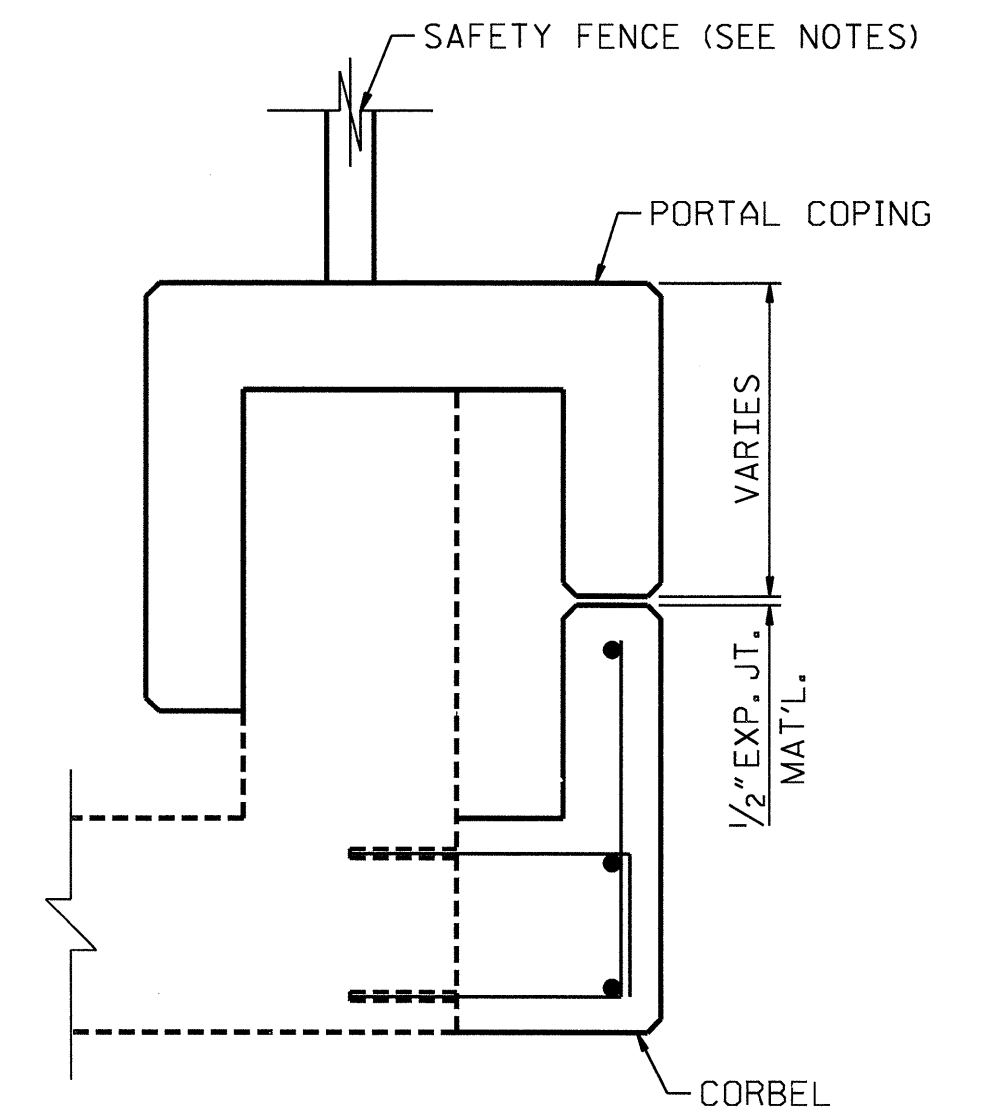

SECTION B-B

PROJECT NO. U-4014
BUNCOMBE COUNTY
 STATION: _____



STATE OF NORTH CAROLINA
 DEPARTMENT OF TRANSPORTATION
 RALEIGH

AESTHETIC TREATMENTS
 (1 OF 6)

REVISIONS						SHEET NO. S-19
NO.	BY:	DATE:	NO.	BY:	DATE:	
1			3			TOTAL SHEETS 30
2			4			

DRAWN BY : M. SELLS DATE : 06/12
 CHECKED BY : J. TAYLOR DATE : 06/12

HDR HDR Engineering, Inc. of the Carolinas
 3733 National Drive, Suite 207 Raleigh, N.C. 27612
 N.C.B.E.L.S. License Number: F-0116

PLOT DRIVER: NCDOT_pdf_mono_eng_50.plt
 USER: msells DATE: 9/7/2012 TIME: 1:43:57 PM
 FILE: North Carolina Dept. of Transportation\NCDOT_U-4014_McDowell_Street\13.00_CAD\U-4014\Structures\U4014_SD_AEL.01.dgn

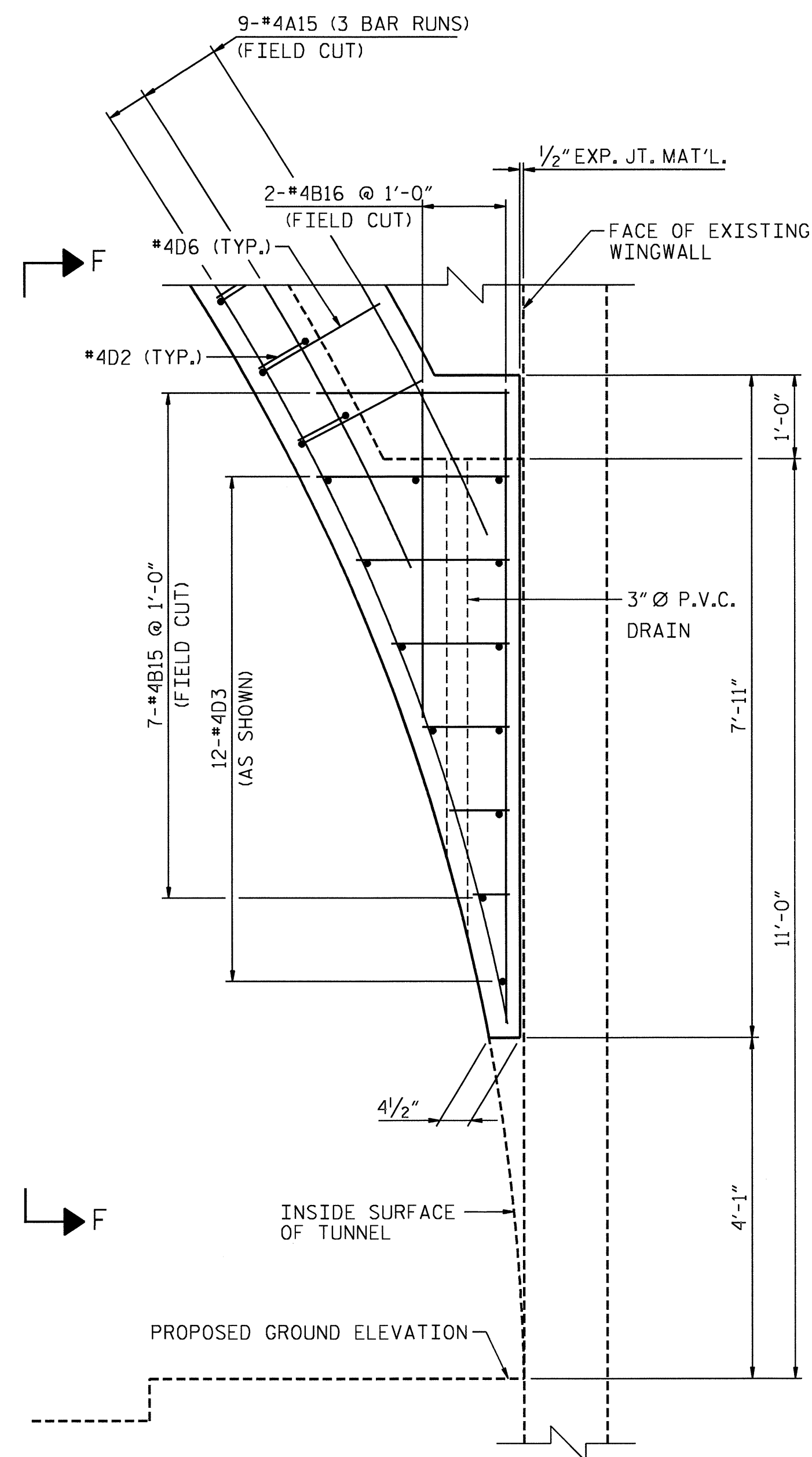

DETAIL 1

END BLOCK NOT SHOWN.
SEE "AESTHETIC TREATMENTS (3 OF 6)".

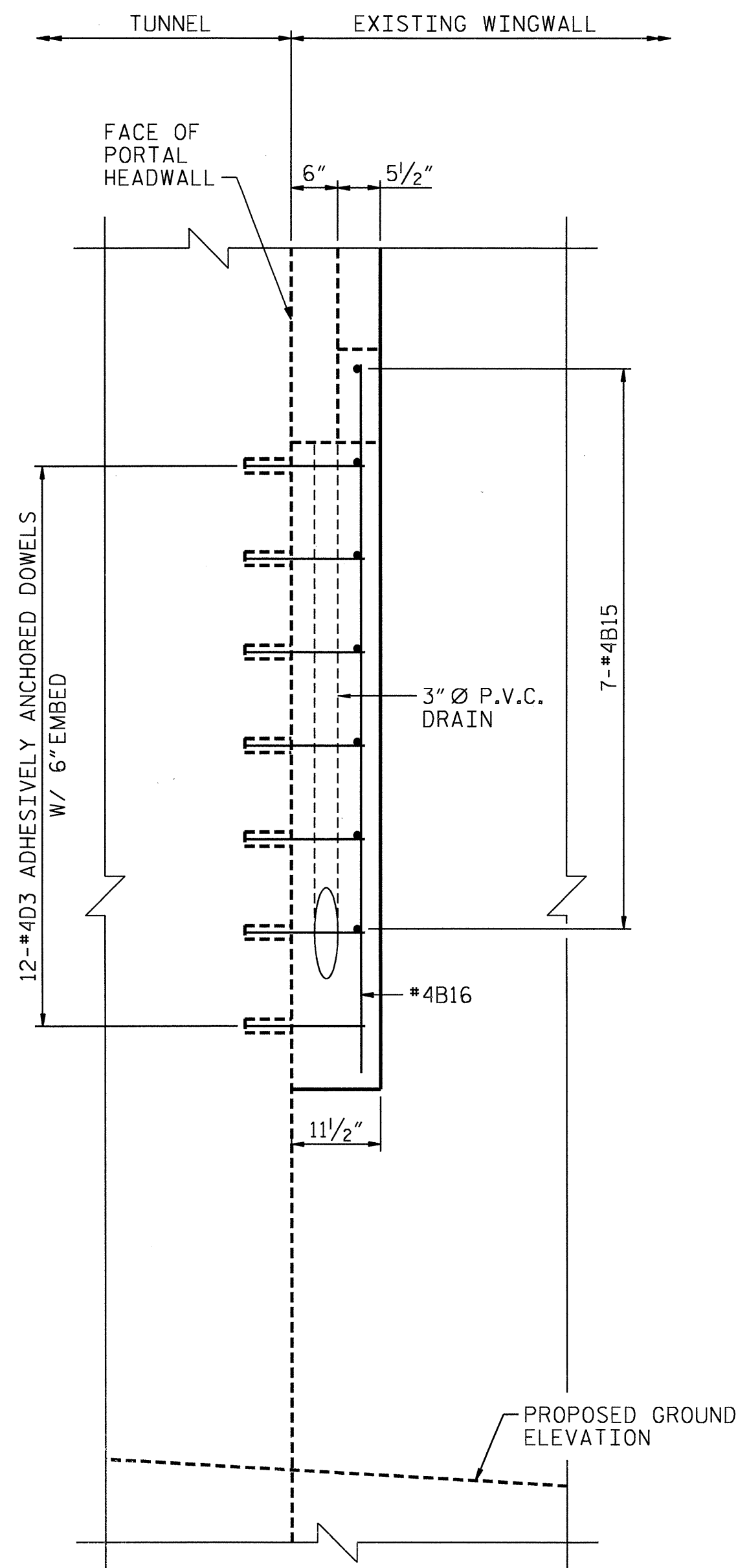

VIEW F-F

END BLOCK NOT SHOWN.
SEE "AESTHETIC TREATMENTS (3 OF 6)".

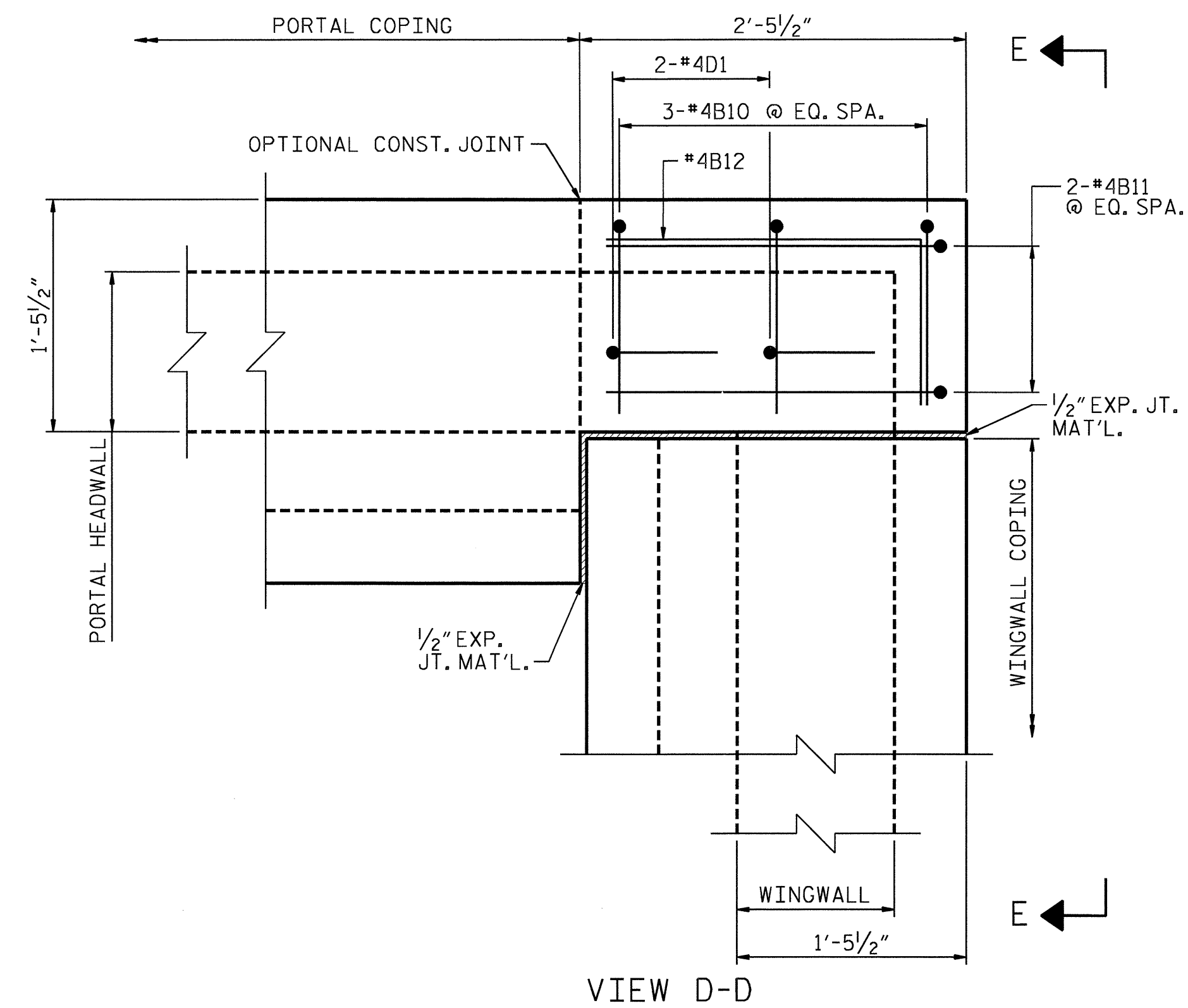

VIEW D-D

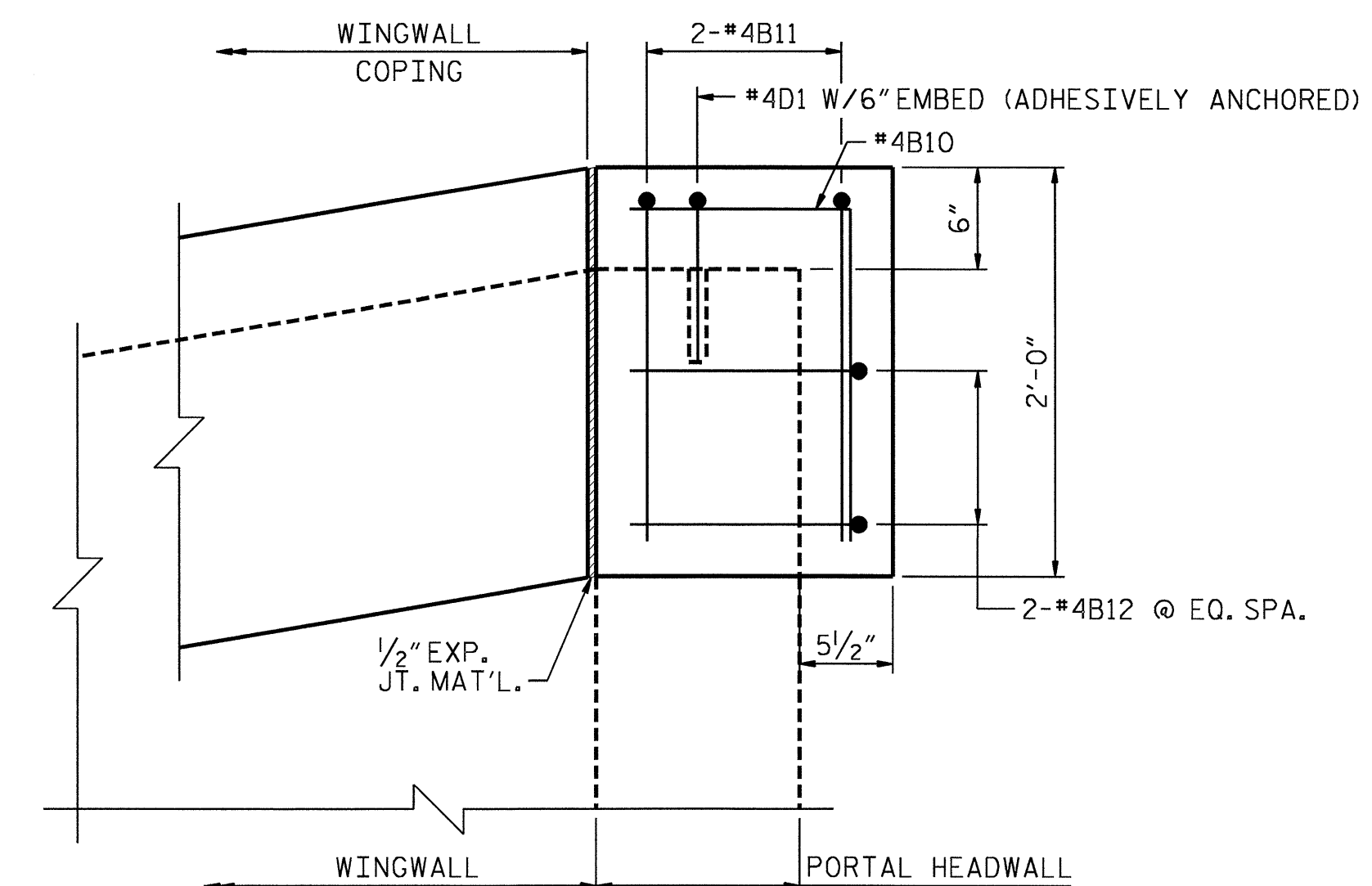

VIEW E-E

PORTAL-TO-WINGWALL TRANSITION SECTION
(4 REQ'D)

PROJECT NO. U-4014
BUNCOMBE COUNTY
STATION: _____



STATE OF NORTH CAROLINA
DEPARTMENT OF TRANSPORTATION
RALEIGH

AESTHETIC TREATMENTS
(2 OF 6)

DRAWN BY : M. SELLS DATE : 06/12
CHECKED BY : J. TAYLOR DATE : 06/12

REVISIONS						SHEET NO. S-20
NO.	BY:	DATE:	NO.	BY:	DATE:	
1			3			TOTAL SHEETS 30
2			4			

HDR HDR Engineering, Inc. of the Carolinas
3733 National Drive, Suite 207 Raleigh, N.C. 27612
N.C.E.L.S. License Number: F-016

PLOT DRIVER: NCDOT_pdf_mono_eng_50.ppt
 USER: msells DATE: 9/7/2012
 FILE: North Carolina Dept. of Transportation\NCDOT\U-4014_McDowell\Structure\U014_SD_AE2.01.dgn

NOTES
 FOR NOTES, SEE "GENERAL NOTES & TOTAL BILL OF MATERIAL."
 FOR SECTION I-I, VIEW J-J AND SECTION K-K, SEE "AESTHETIC TREATMENTS (4 OF 6)".

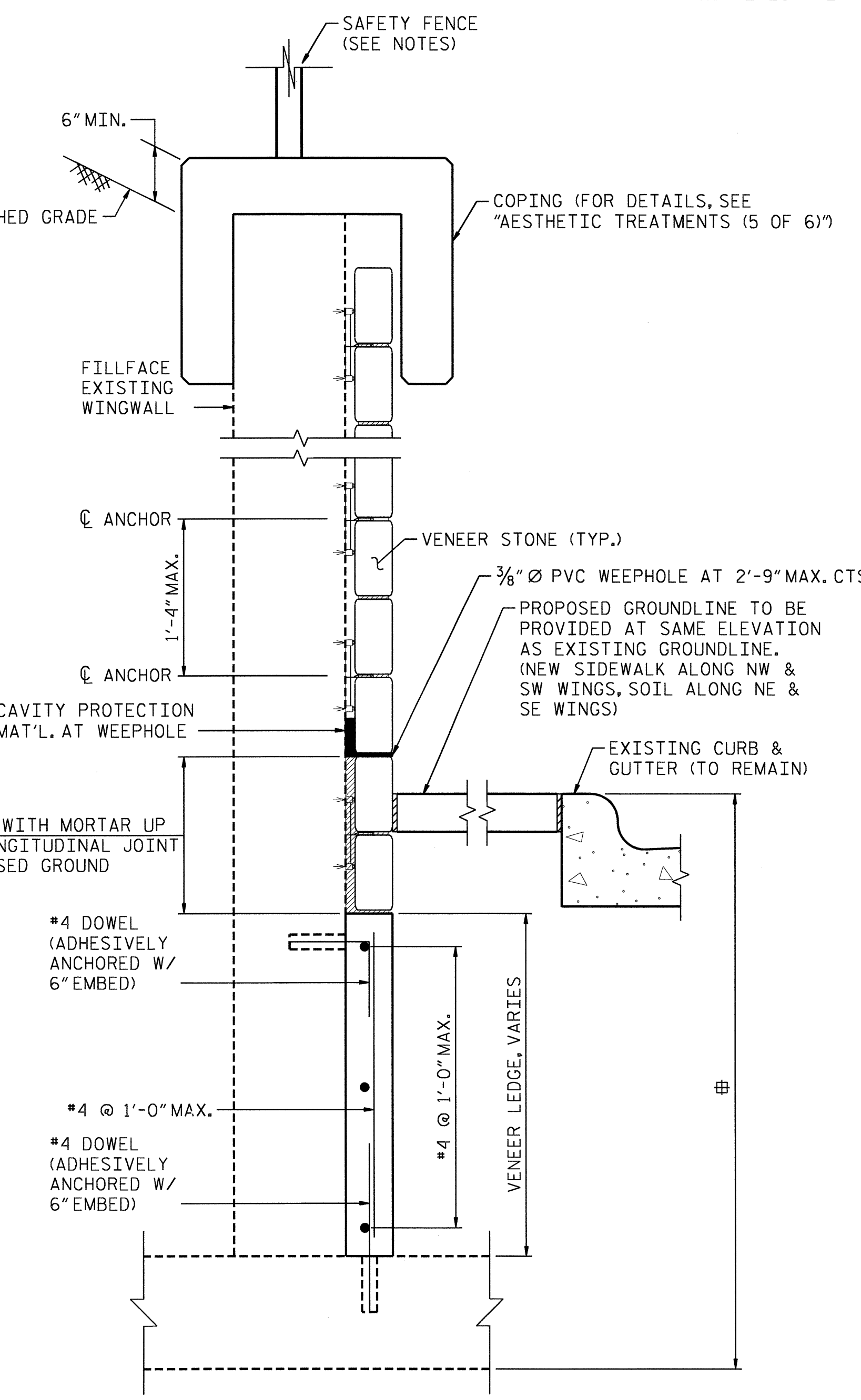
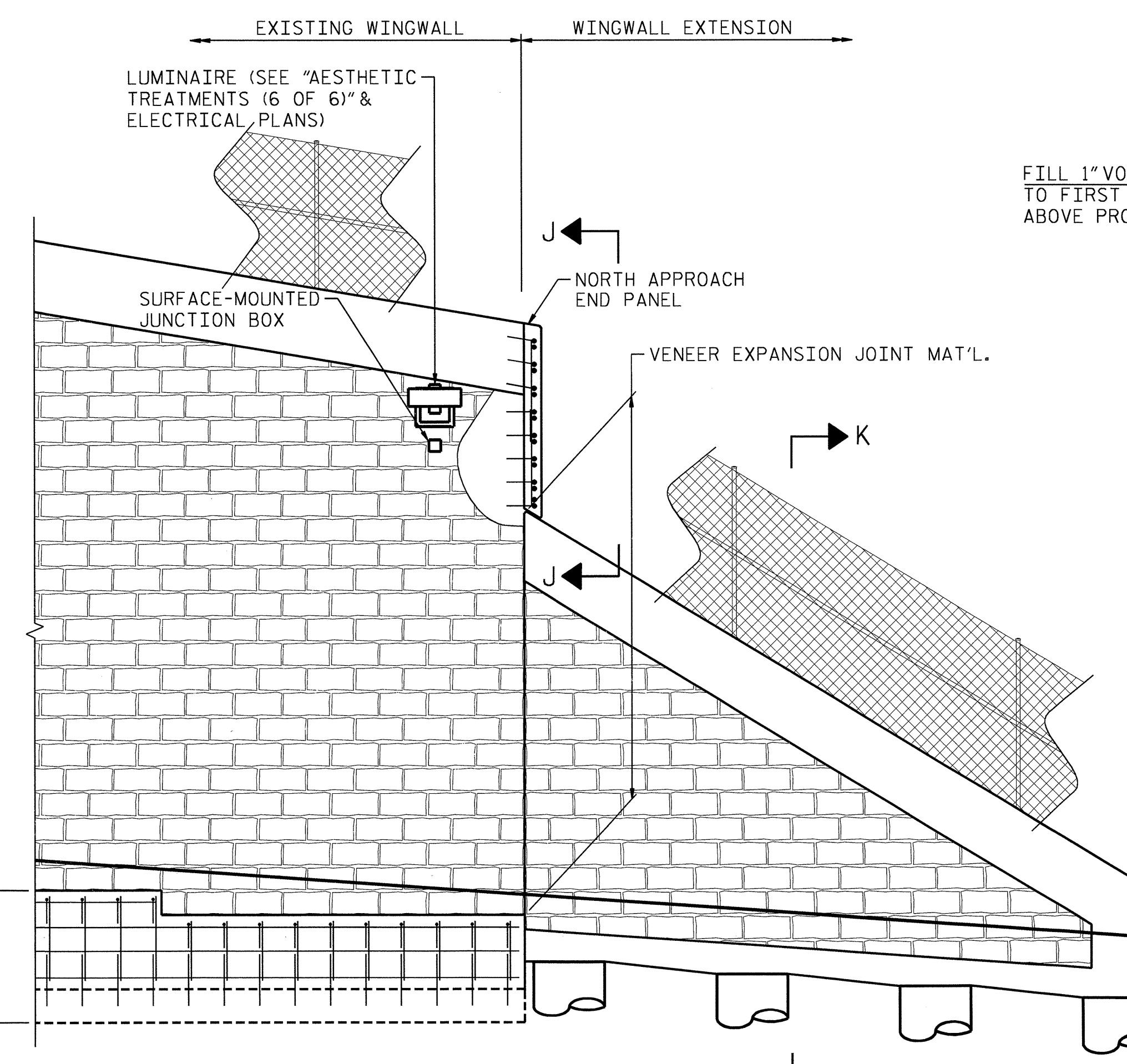
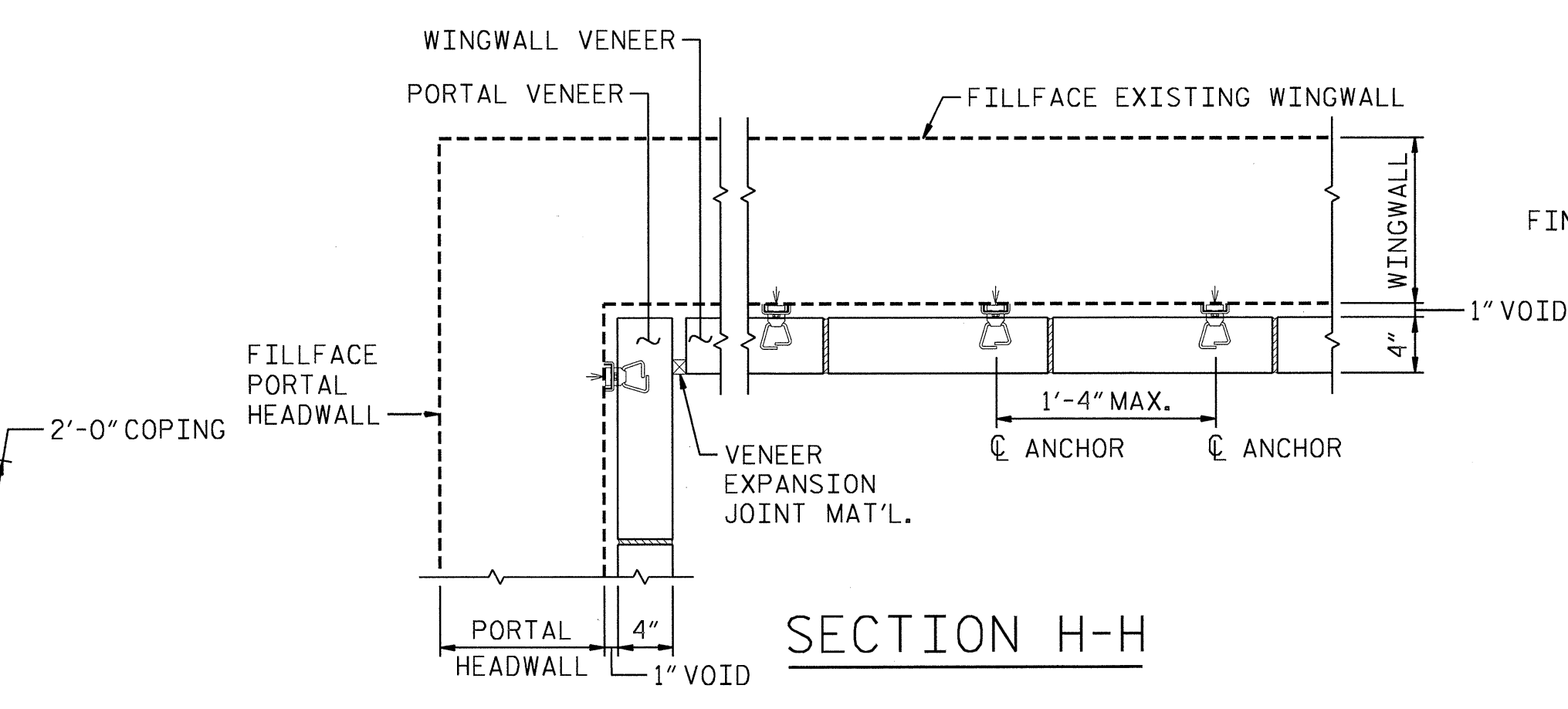
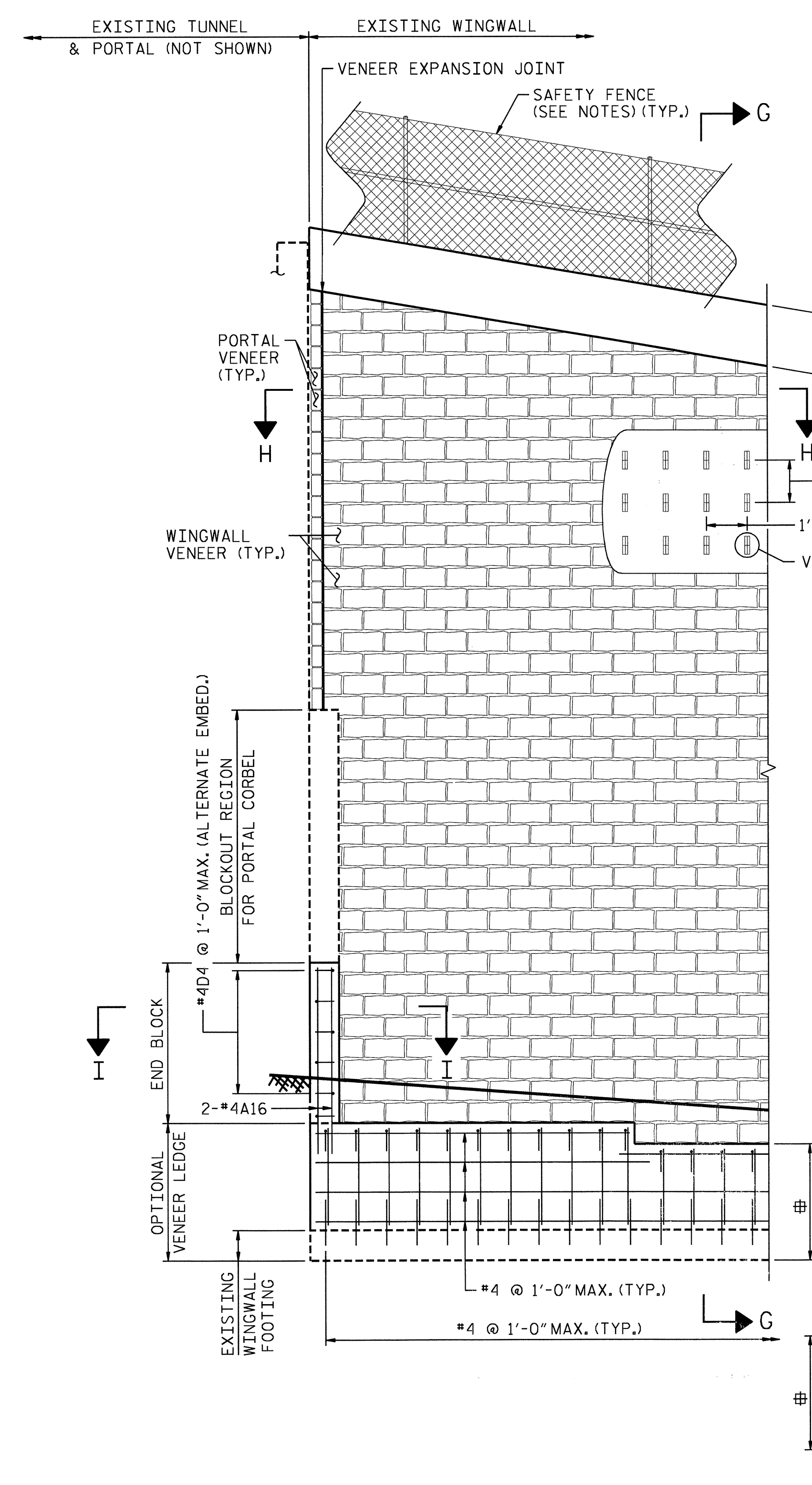

WINGWALL ELEVATION
 (NORTHWEST WINGWALL SHOWN, OTHERS SIMILAR)

PROJECT NO. U-4014
 BUNCOMBE COUNTY
 STATION: _____



STATE OF NORTH CAROLINA
 DEPARTMENT OF TRANSPORTATION
 RALEIGH
AESTHETIC TREATMENTS
 (3 OF 6)

⊕ SUBSURFACE GEOMETRY OF EXISTING WINGWALLS UNKNOWN. DETAILS SHOWN DEPICT INTENT REGARDING POSITION OF BOTTOM OF VENEER RELATIVE TO PROPOSED GROUNDLINE. AT THE CONTRACTOR'S DISCRETION, THE VENEER MAY BE EXTENDED TO TOP OF EXISTING FOOTING IN LIEU OF PROVIDING THE C.I.P. LEDGE.

DRAWN BY: M. SELLS DATE: 06/12
 CHECKED BY: J. TAYLOR DATE: 06/12

HDR Engineering, Inc. of the Carolinas
 3733 National Drive, Suite 207 Raleigh, N.C. 27612
 N.C.B.E.L.S. License Number: F-0116

REVISIONS						SHEET NO. 5-21 TOTAL SHEETS 30
NO.	BY:	DATE:	NO.	BY:	DATE:	
1			3			
2			4			

PLOT DRIVER: NCDOT_pdf_mono_eng_50.plt
 USER: msells
 DATE: 9/7/2012
 FILE: North Carolina Dept. of Transportation\NCDOT\U-4014_McDowell\Structure\U4014_SD_AE3_01.dgn

NOTES
 FOR NOTES, SEE "GENERAL NOTES & TOTAL BILL OF MATERIAL".

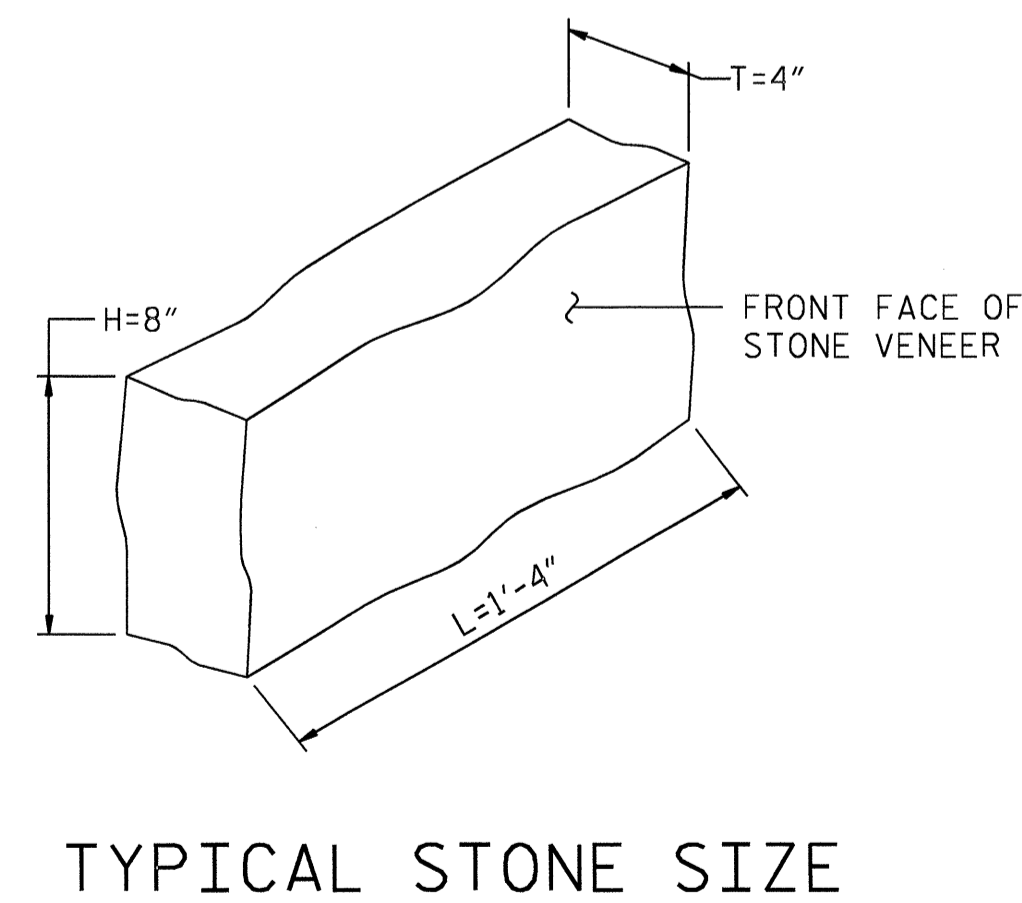
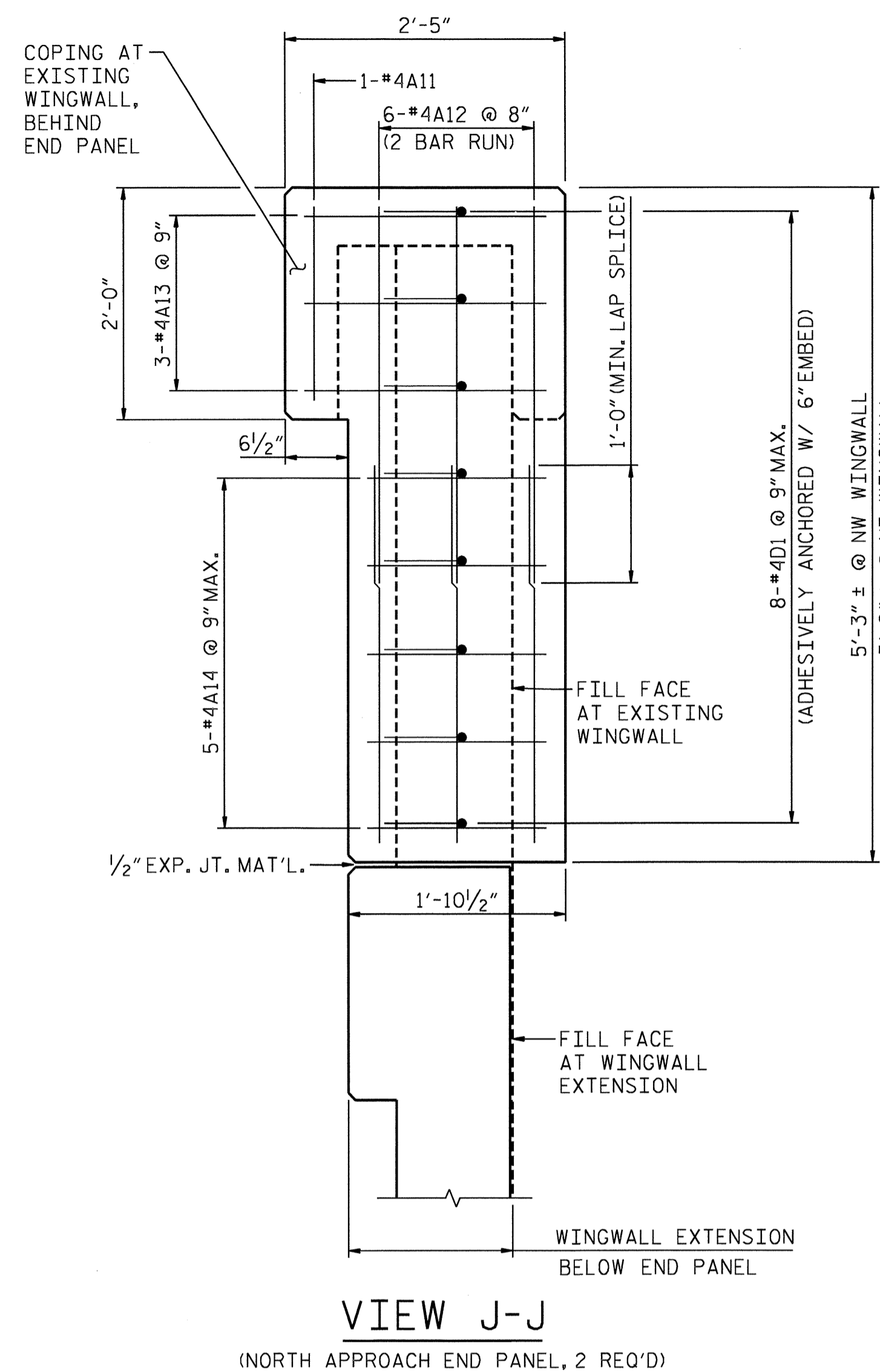
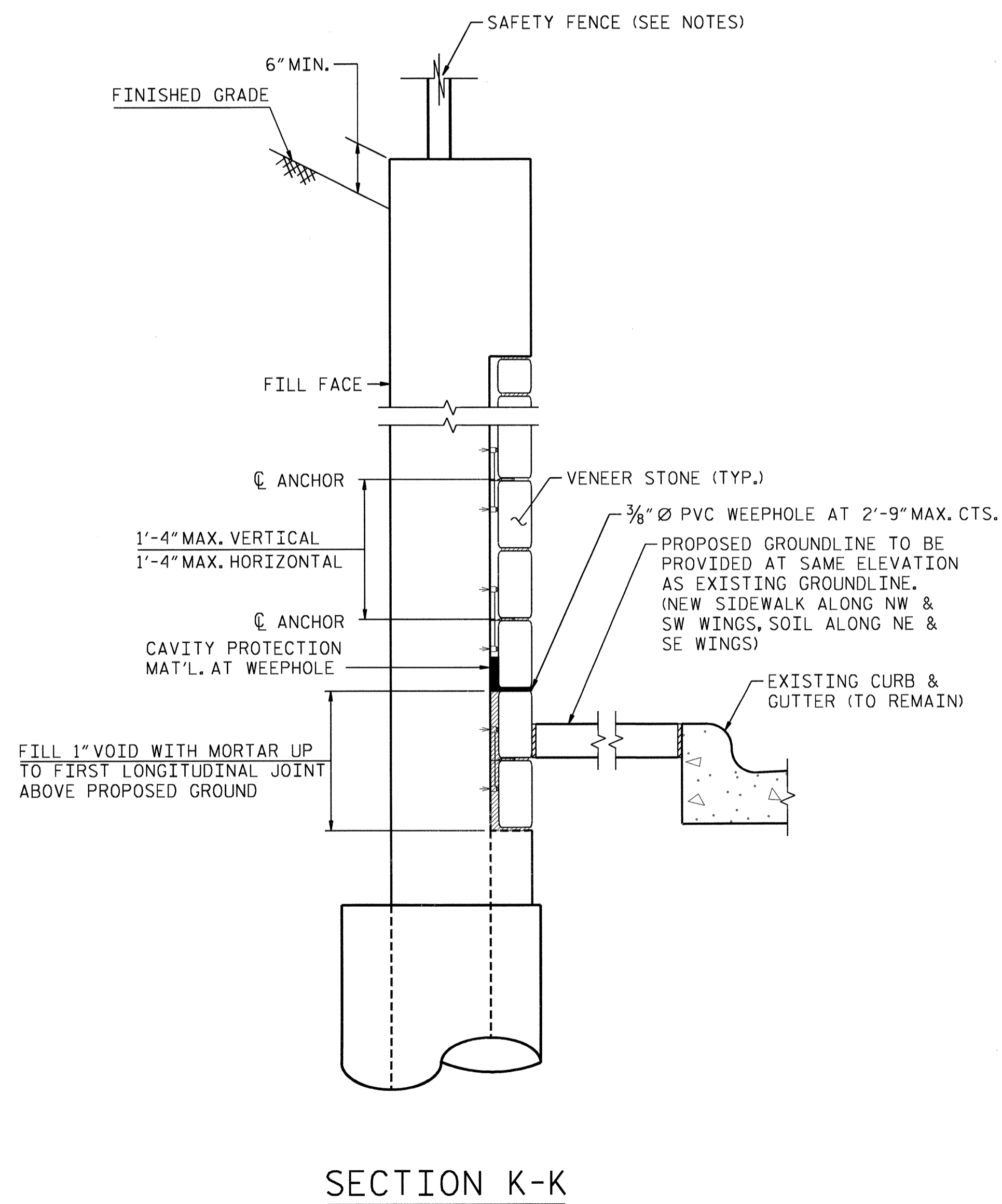
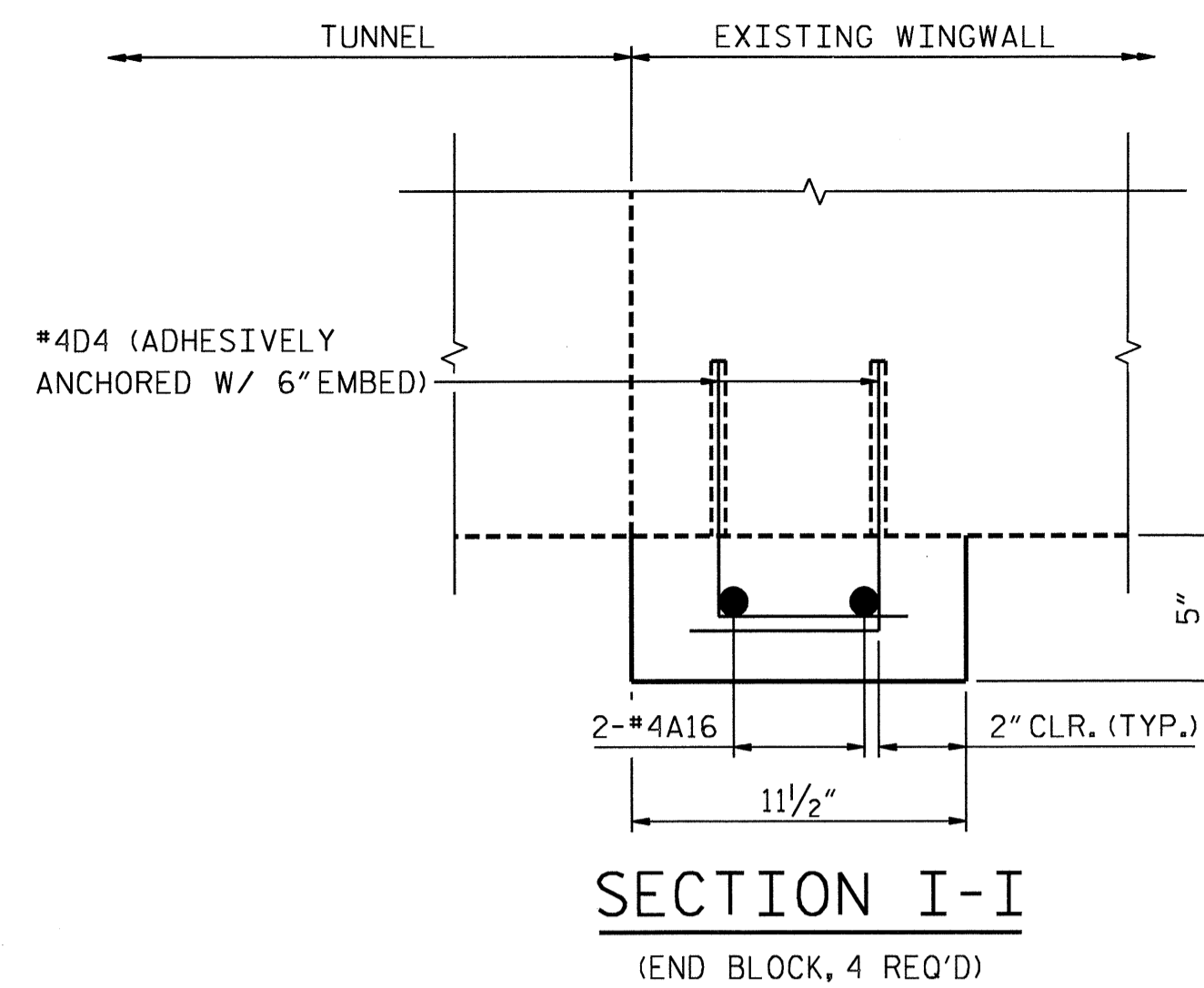

PROJECT NO. U-4014
BUNCOMBE COUNTY
 STATION: _____

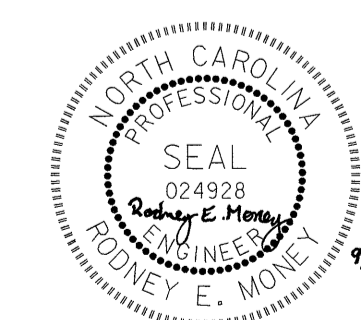

STATE OF NORTH CAROLINA
 DEPARTMENT OF TRANSPORTATION
 RALEIGH

AESTHETIC TREATMENTS
 (4 OF 6)

REVISIONS						SHEET NO. 5-22
NO.	BY:	DATE:	NO.	BY:	DATE:	
1			3			TOTAL SHEETS 30
2			4			

DRAWN BY: M. SELLS DATE: 06/12
 CHECKED BY: J. TAYLOR DATE: 06/12

HDR HDR Engineering, Inc. of the Carolinas
 3733 National Drive, Suite 207 Raleigh, N.C. 27612
 N.C.B.E.L.S. License Number: F-0116

PLOT DRIVER: NCDOT_pdf_mono_eng_50.plt
 USER: msells DATE: 9/7/2012 TIME: 1:44:37 PM
 FILE: North Carolina Dept. of Transportation\NCDOT_U-4014_McDowell_Strip\13.00_CAD\U-4014\Structures\U4014_SD_AE4_01.dgn

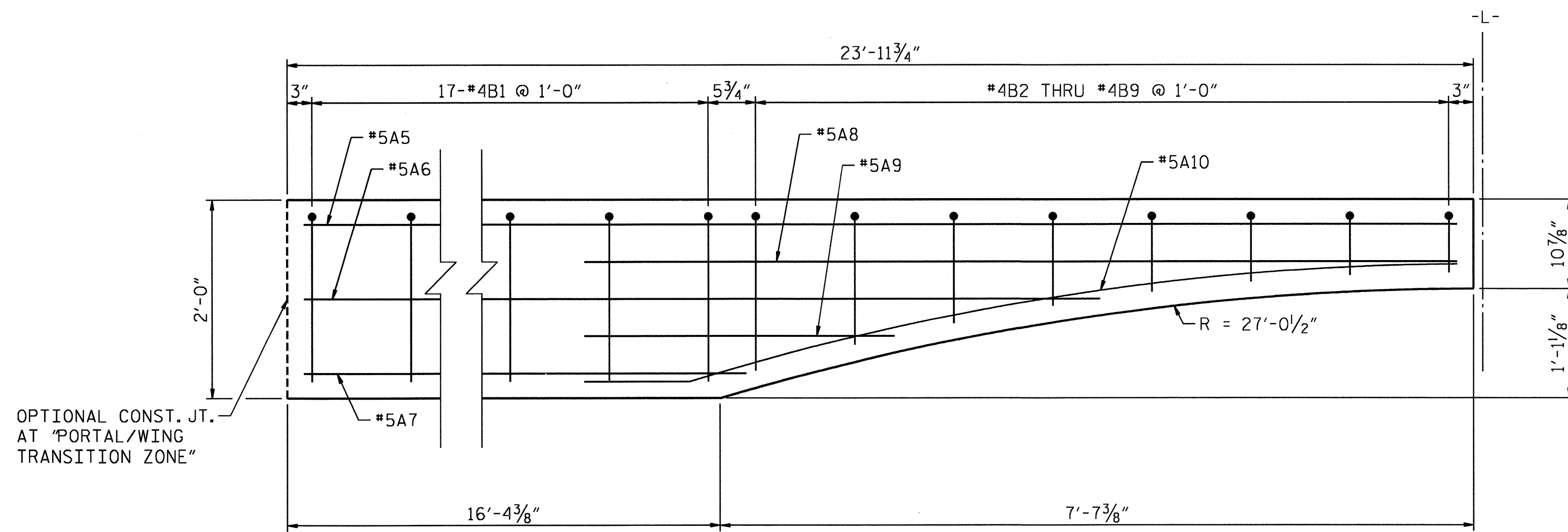

PORTAL COPING - ELEVATION

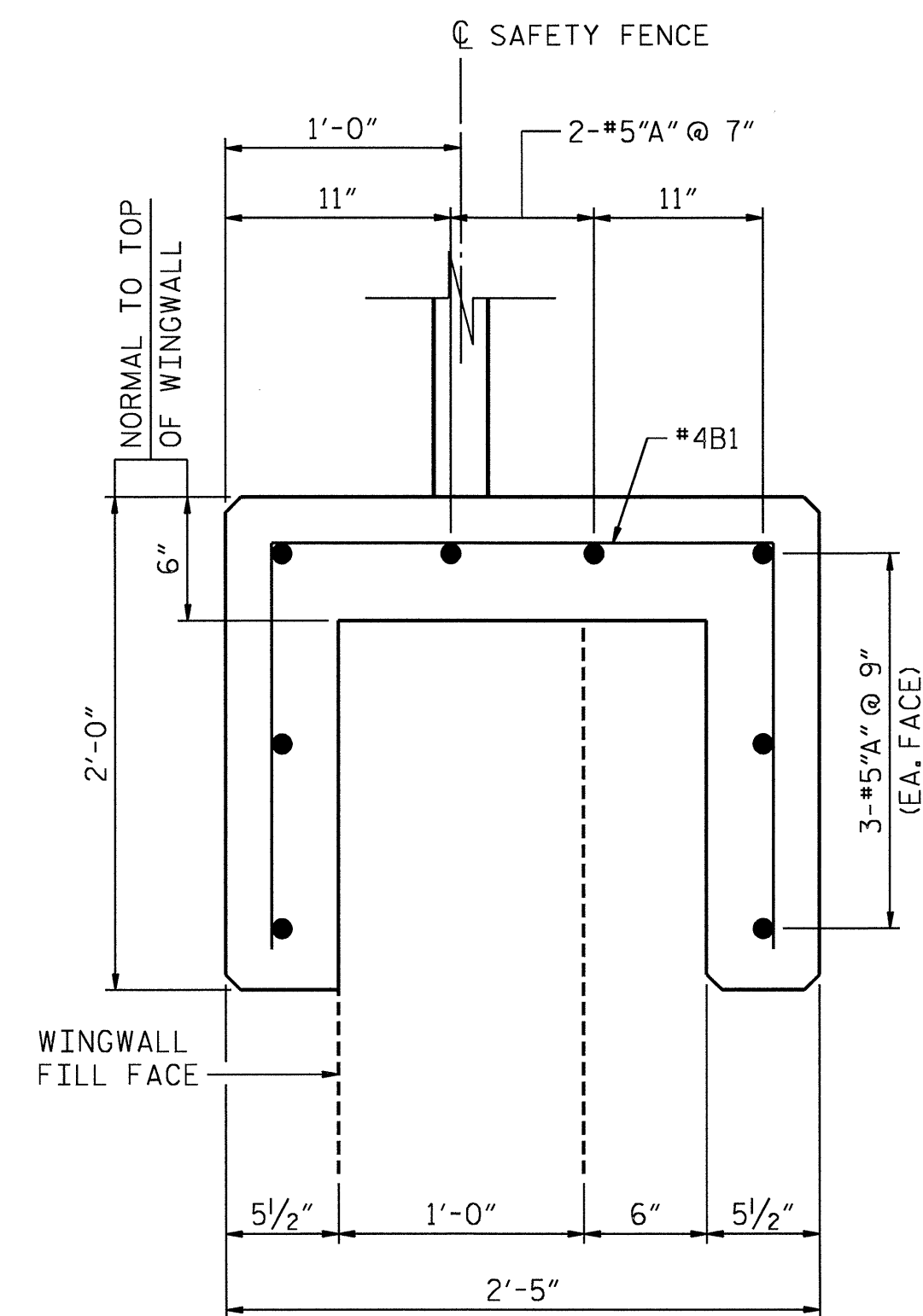

WINGWALL COPING SECTION

(PORTAL COPING SECTION SIMILAR)

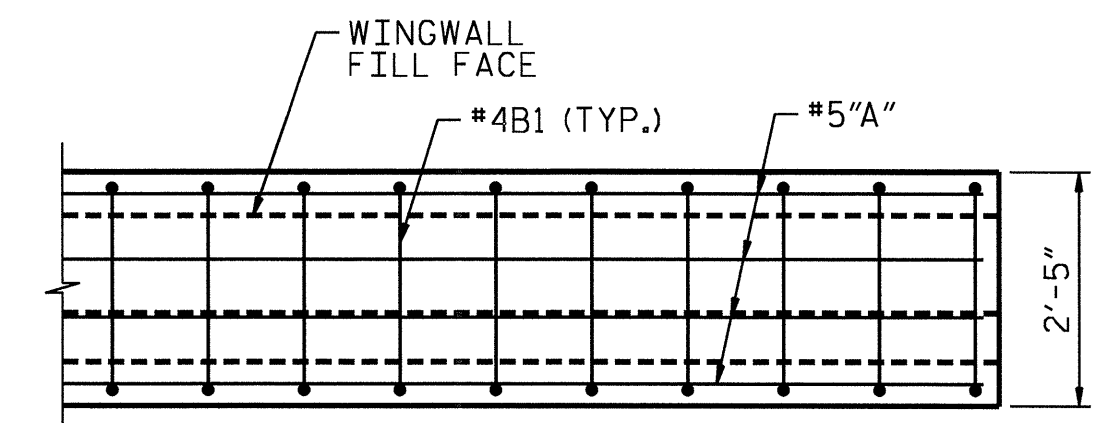

WINGWALL COPING - PART PLAN

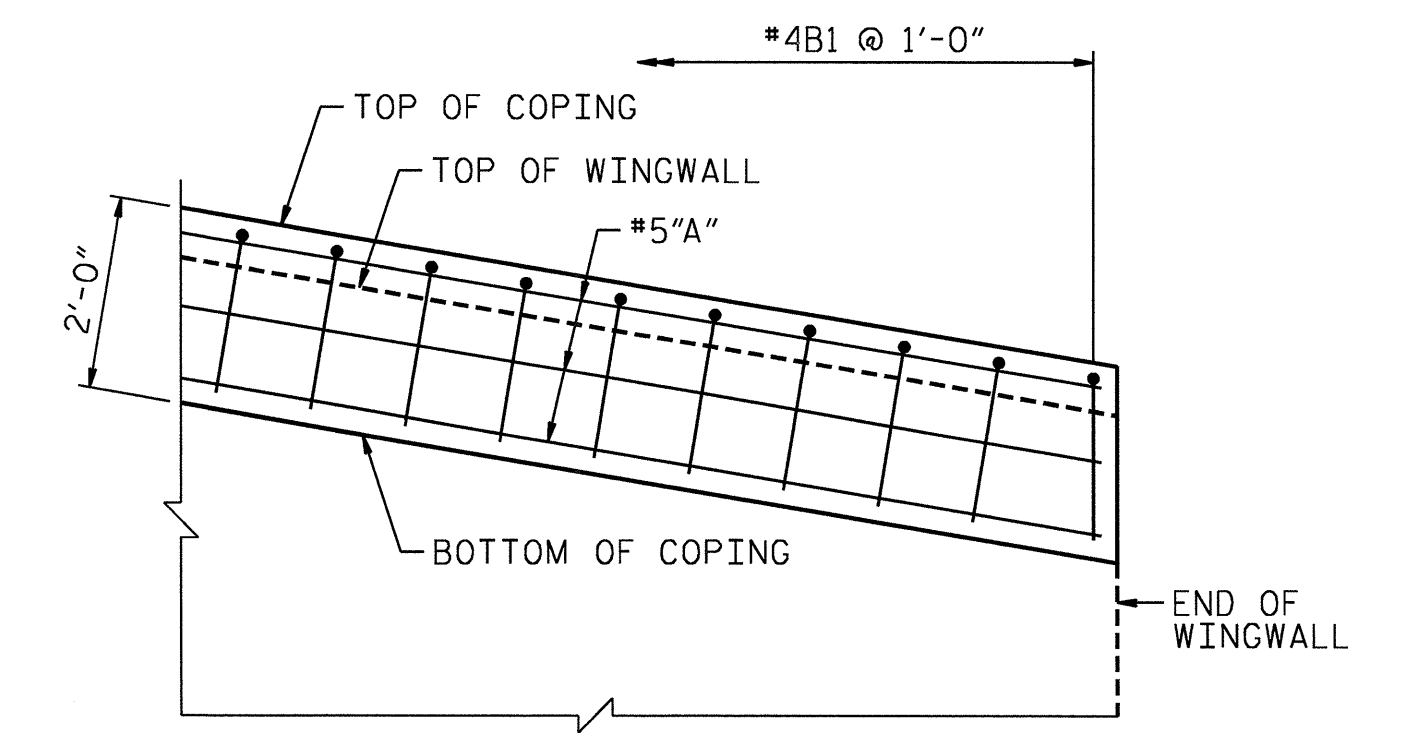

WINGWALL COPING - PART ELEVATION

#5\"/>

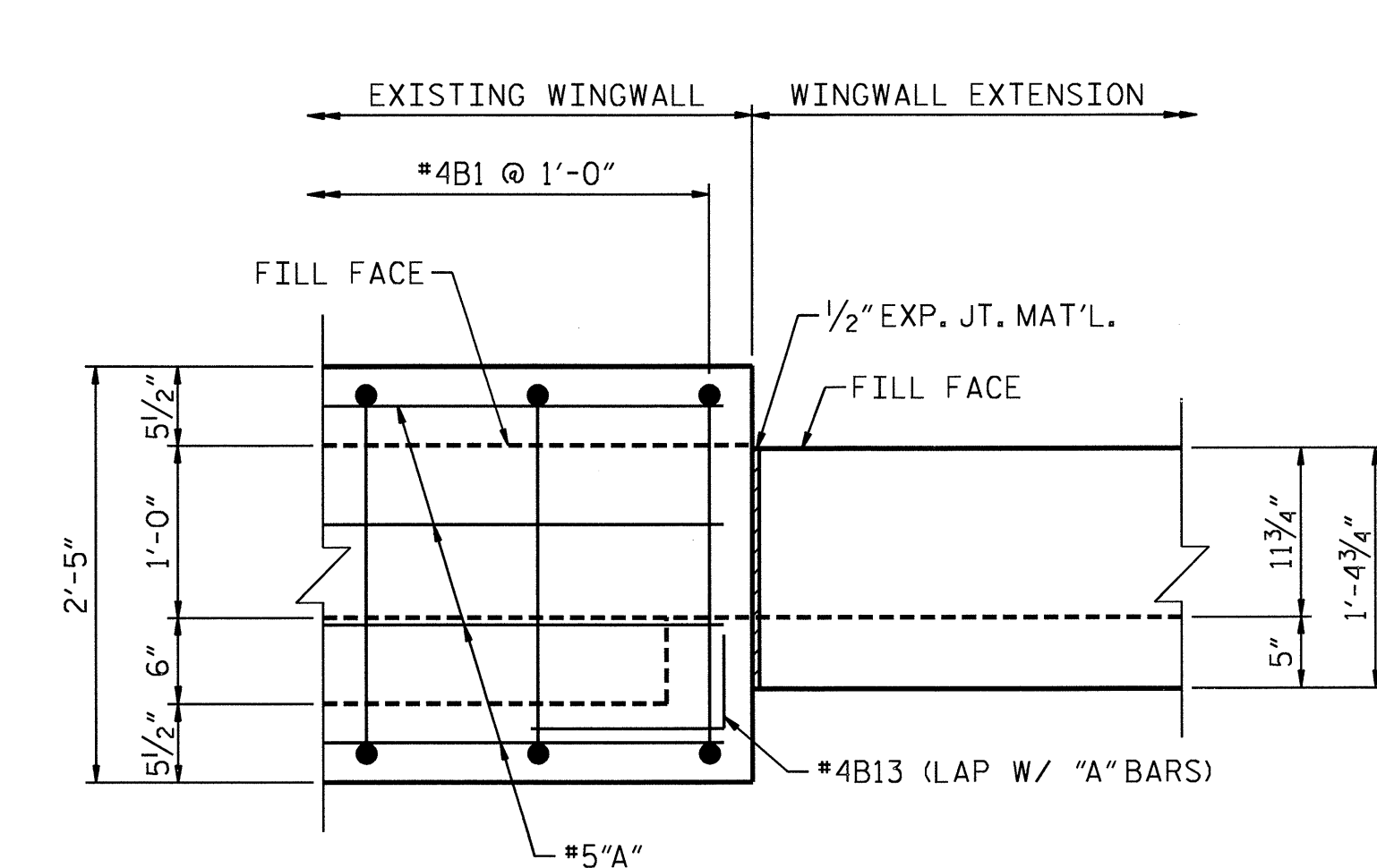

PLAN

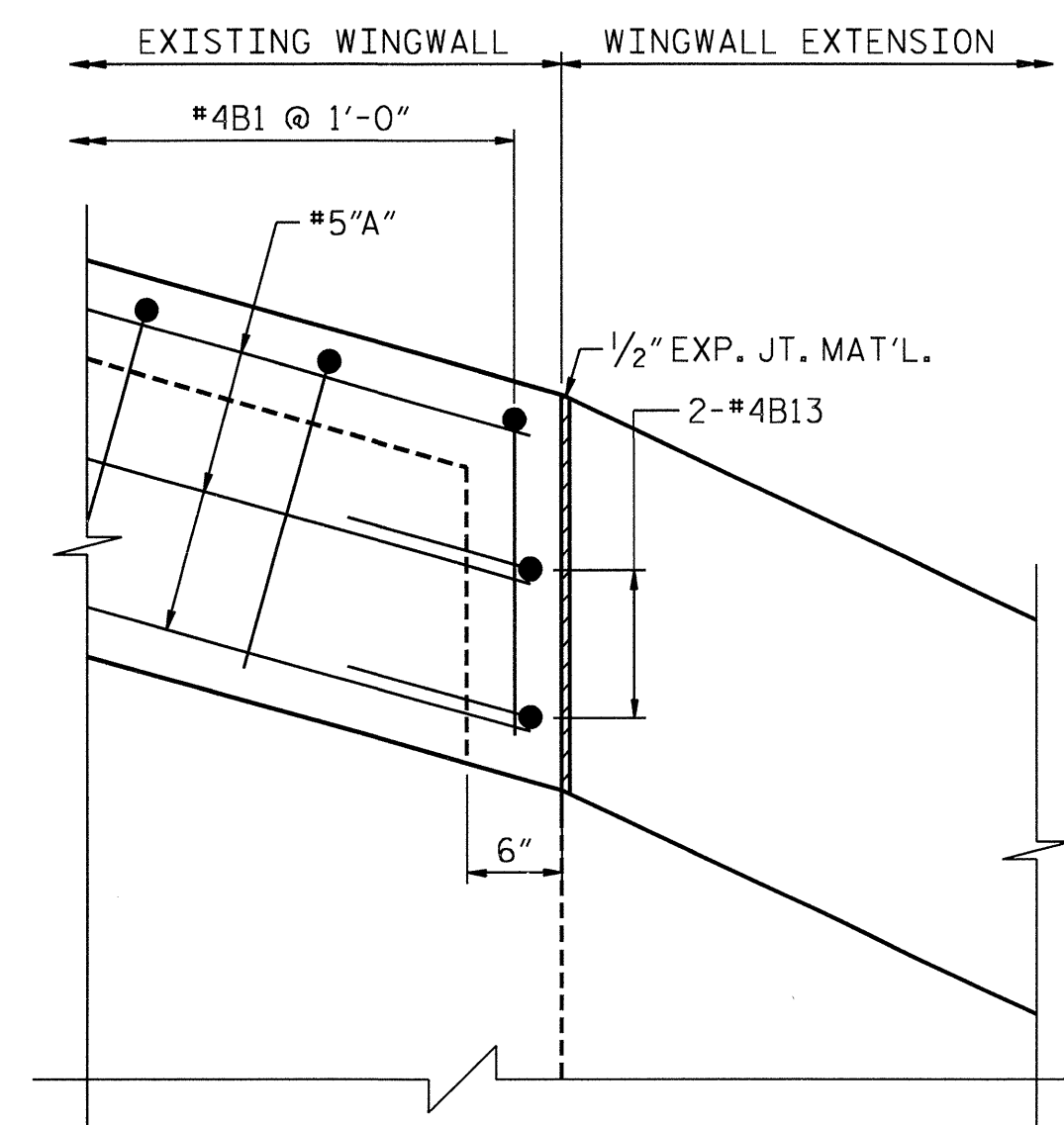

ELEVATION

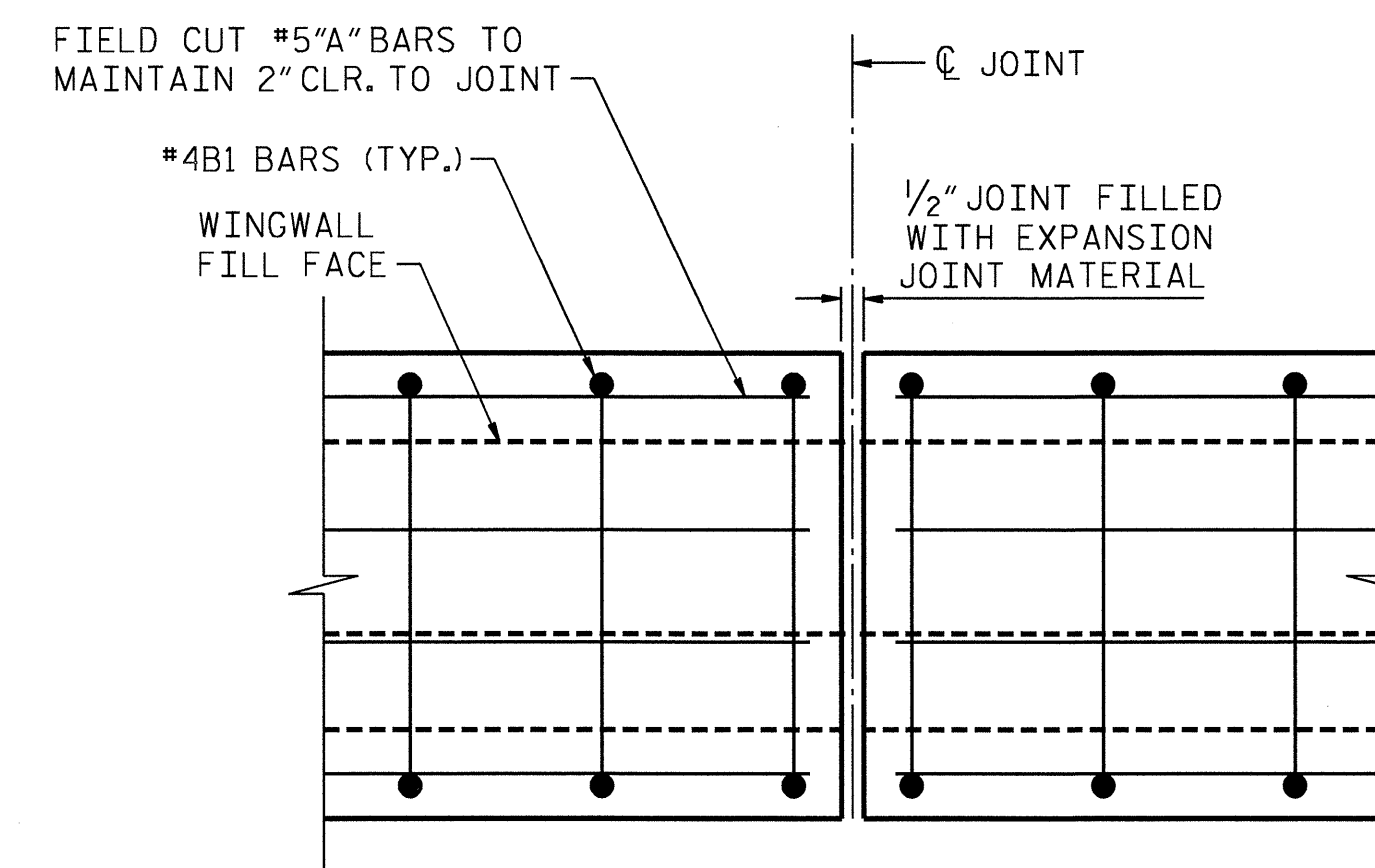

WINGWALL COPING - EXP. JT. DETAIL

PROJECT NO. U-4014
 BUNCOMBE COUNTY
 STATION: _____

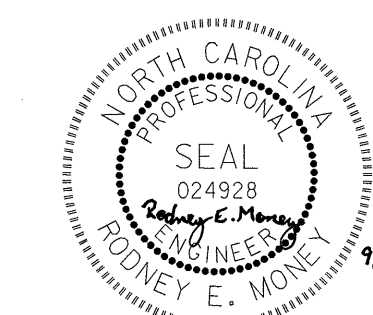

STATE OF NORTH CAROLINA
 DEPARTMENT OF TRANSPORTATION
 RALEIGH
 AESTHETIC TREATMENTS
 (5 OF 6)

REVISIONS						SHEET NO. S-23
NO.	BY:	DATE:	NO.	BY:	DATE:	
1			3			TOTAL SHEETS 30
2			4			

DRAWN BY : M. SELLS DATE : 06/12
 CHECKED BY : J. TAYLOR DATE : 06/12

HDR Engineering, Inc. of the Carolinas
 3783 National Drive, Suite 207 Raleigh, N.C. 27612
 N.C. E.L.S. License Number: F-0116

PLOT DRIVER: NCDOT_pdf_mono_eng_50.plt
 USER: msells
 PENTABLE: MDT_pen.tbl
 DATE: 9/7/2012
 TIME: 1:44:47 PM
 FILE: North Carolina Dept. of Transportation\NCDOT_U-4014_McDowell-Street\13.00_CAD\U-4014\Structures\U4014_SD_AE5_01.dgn

END OF EXISTING WINGWALL COPING DETAIL - SOUTH APPROACH

PLOT DRIVER: NCDOT_pcf_mono_eng_50.pit
 USER: msells
 DATE: 9/7/2012
 TIME: 1:44:56 PM
 FILE: North Carolina Dept. of Transportation\NCDOT_U_4014_McDowellStreet\13.00_CAD\U-4014_Structures\U4014_SD_AEG_01.dgn

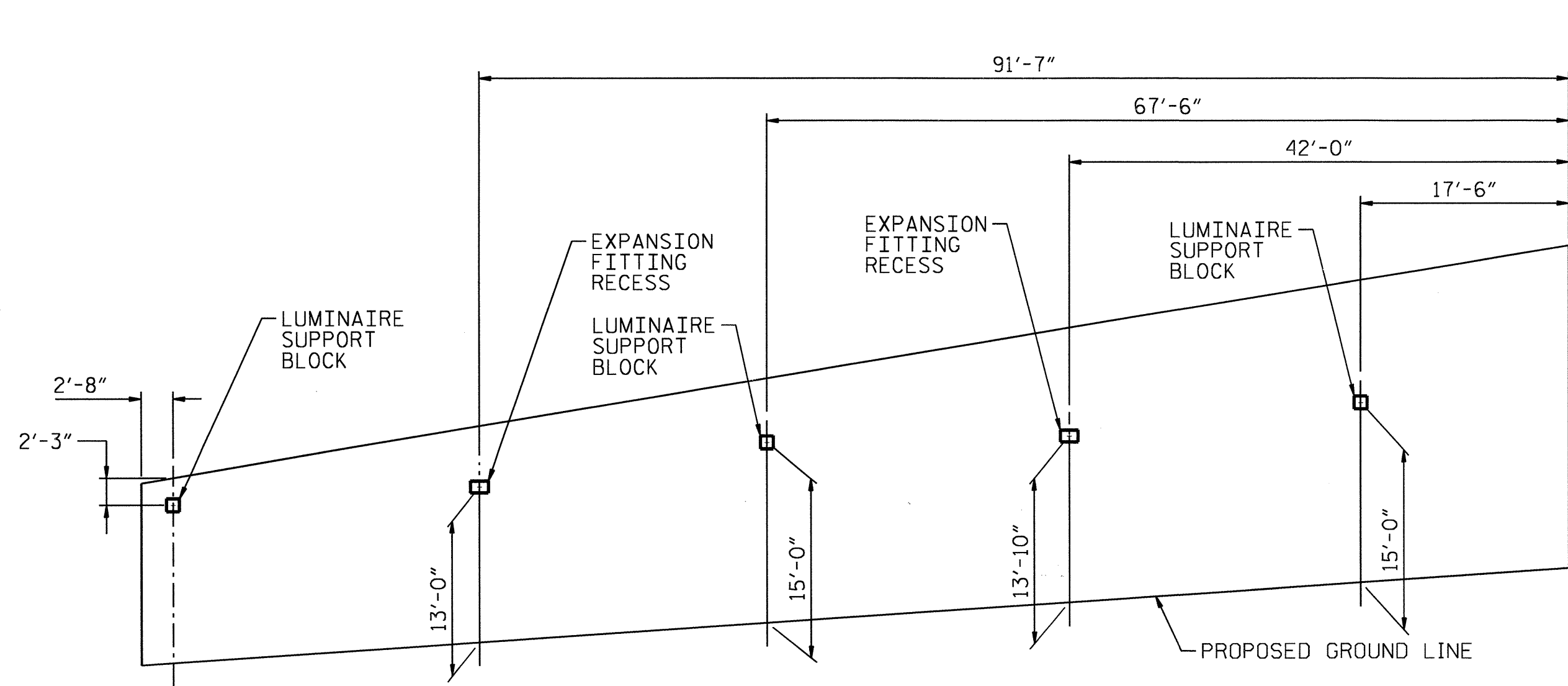

ELEVATION - NORTHEAST WINGWALL

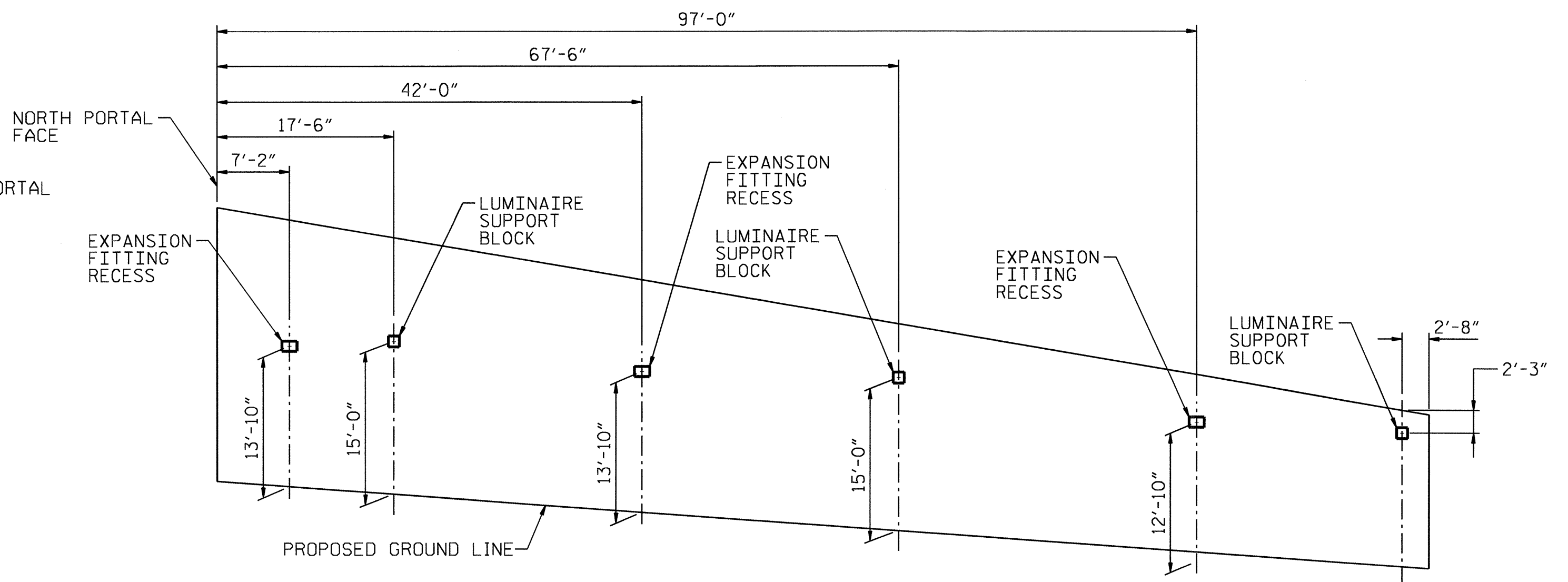

ELEVATION - NORTHWEST WINGWALL

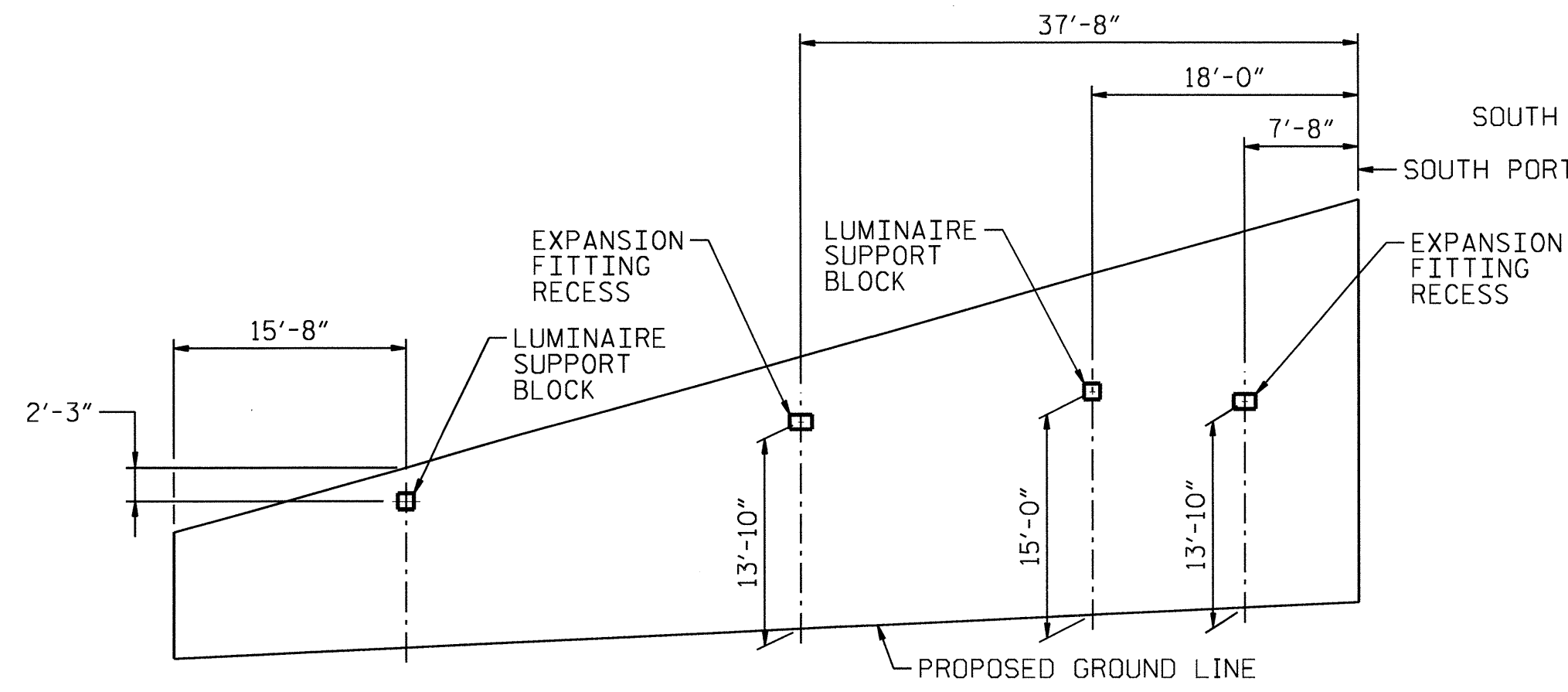

ELEVATION - SOUTHWEST WINGWALL

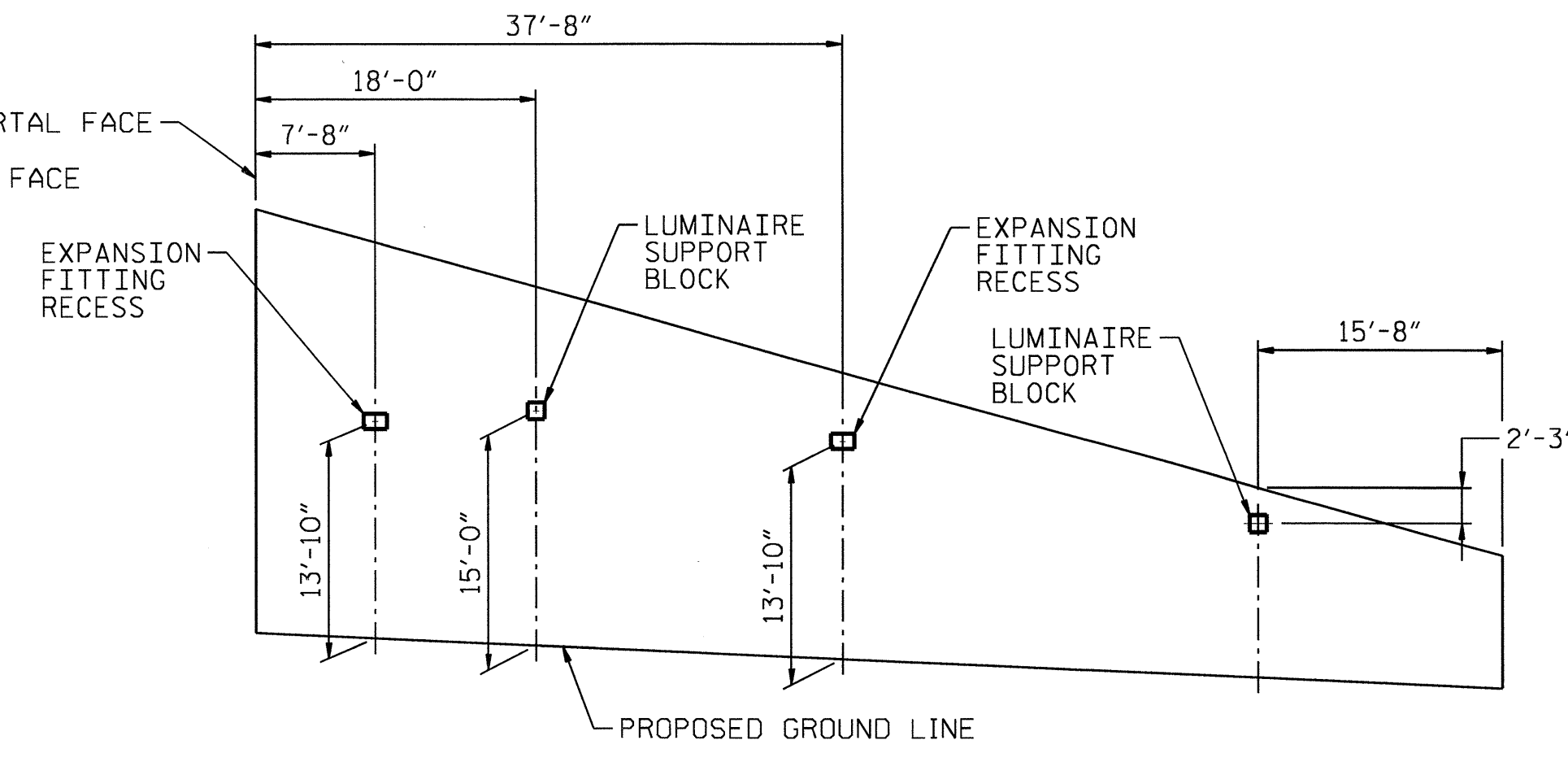

ELEVATION - SOUTHEAST WINGWALL

NOTES
 FOR GENERAL NOTES, SEE SHEET "GENERAL NOTES AND TOTAL BILL OF MATERIAL".
 FOR BILL OF MATERIALS SEE SHEET "BILL OF MATERIAL (C.I.P. CONCRETE CONSTRUCTION)".

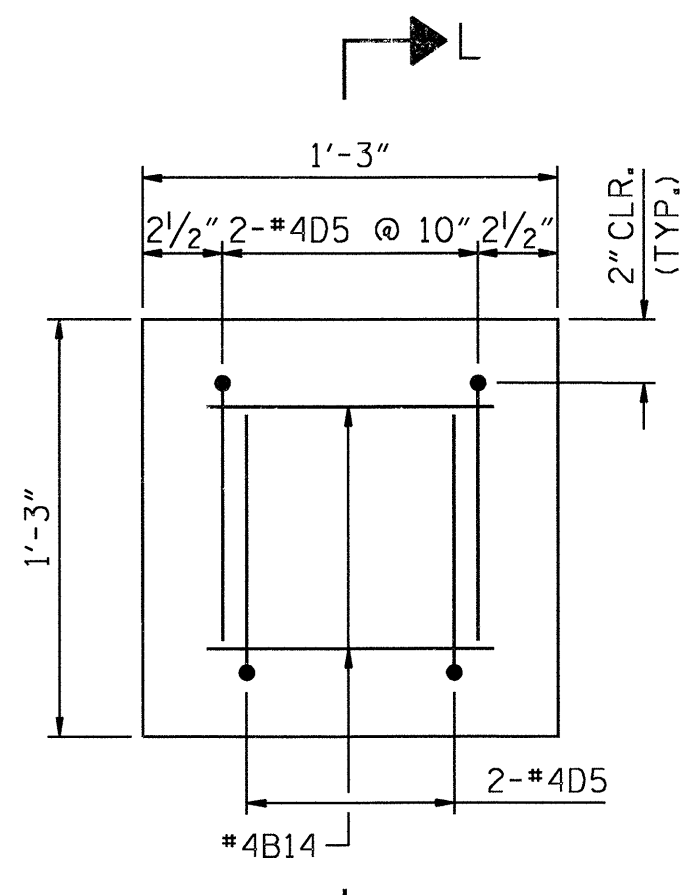

ELEVATION
LUMINAIRE SUPPORT BLOCK

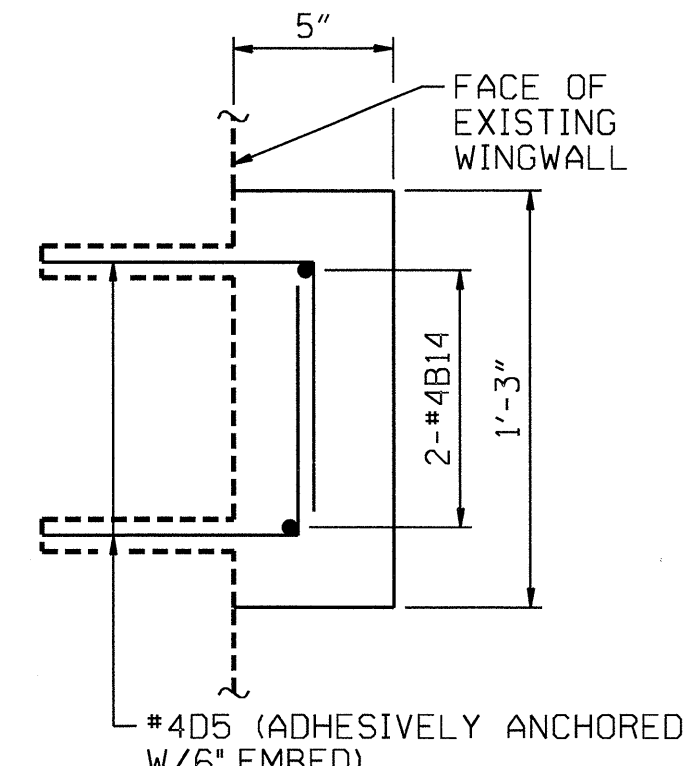

SECTION L-L

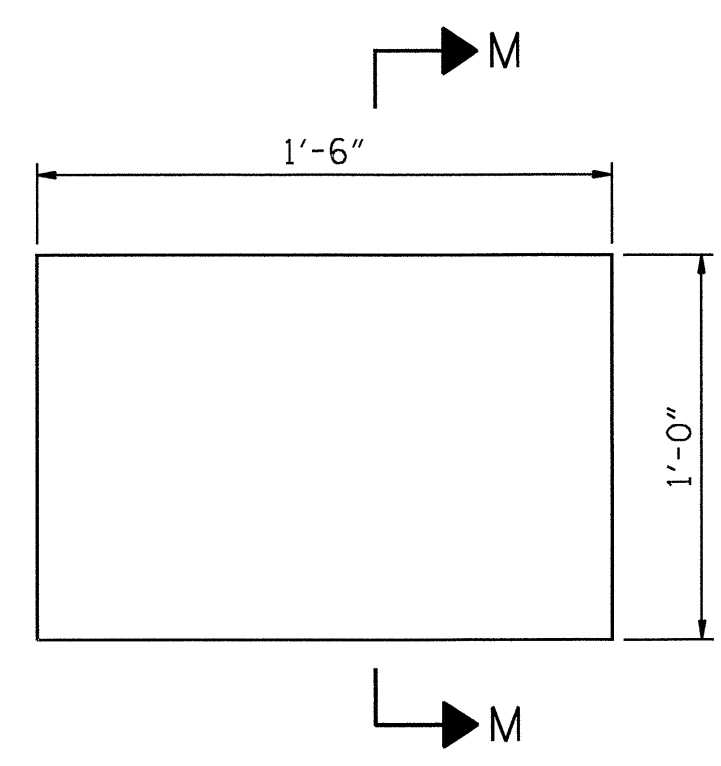

ELEVATION

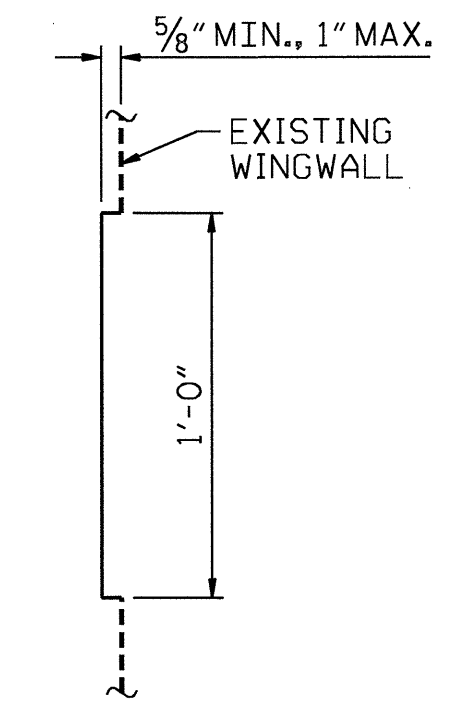

SECTION M-M

EXPANSION FITTING RECESS
 SHOTCRETE SUBCONTRACTOR SHALL PREPARE A SHOTCRETE LINED EXPANSION FITTING RECESS TO THE DIMENSIONS SHOWN.

PROJECT NO. U-4014
BUNCOMBE COUNTY
 STATION: _____



STATE OF NORTH CAROLINA
 DEPARTMENT OF TRANSPORTATION
 RALEIGH
AESTHETIC TREATMENTS
 (6 OF 6)

DRAWN BY : M. SELLS DATE : 07/12
 CHECKED BY : J. TAYLOR DATE : 07/12

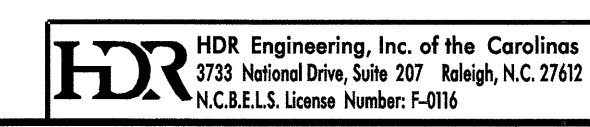

REVISIONS						SHEET NO. 5-24
NO.	BY:	DATE:	NO.	BY:	DATE:	
1			3			TOTAL SHEETS 30
2			4			

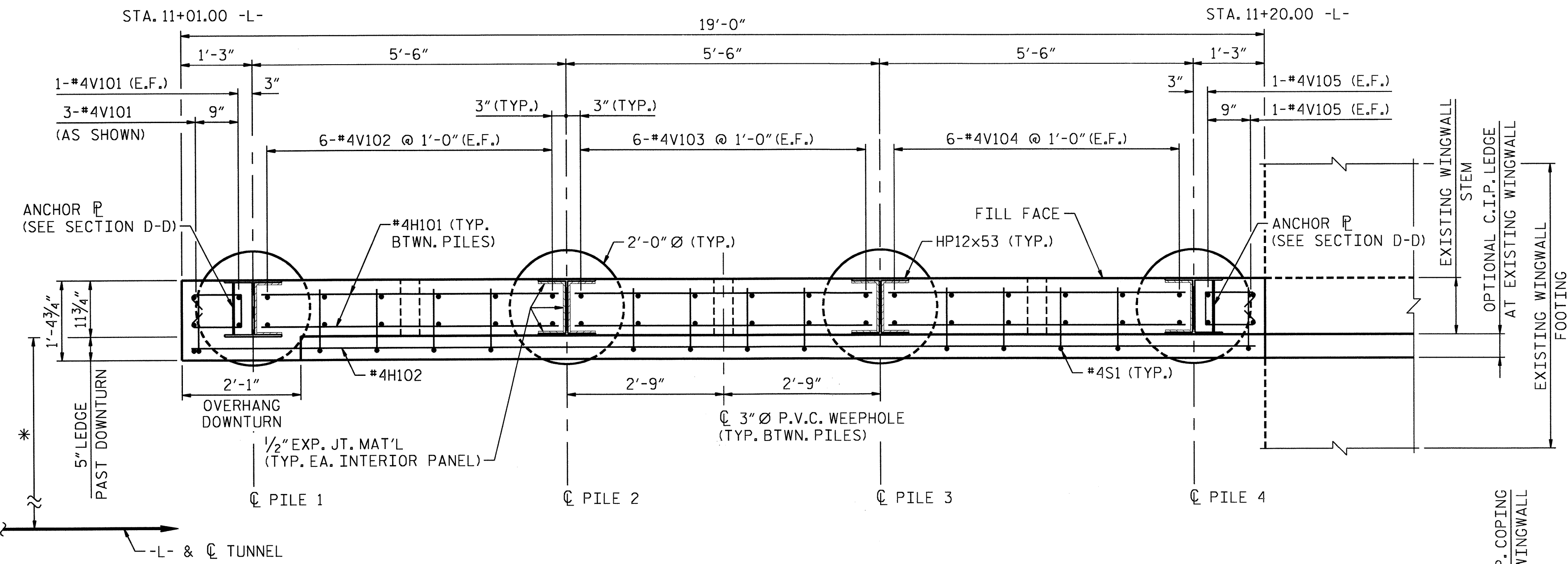

SECTION A-A

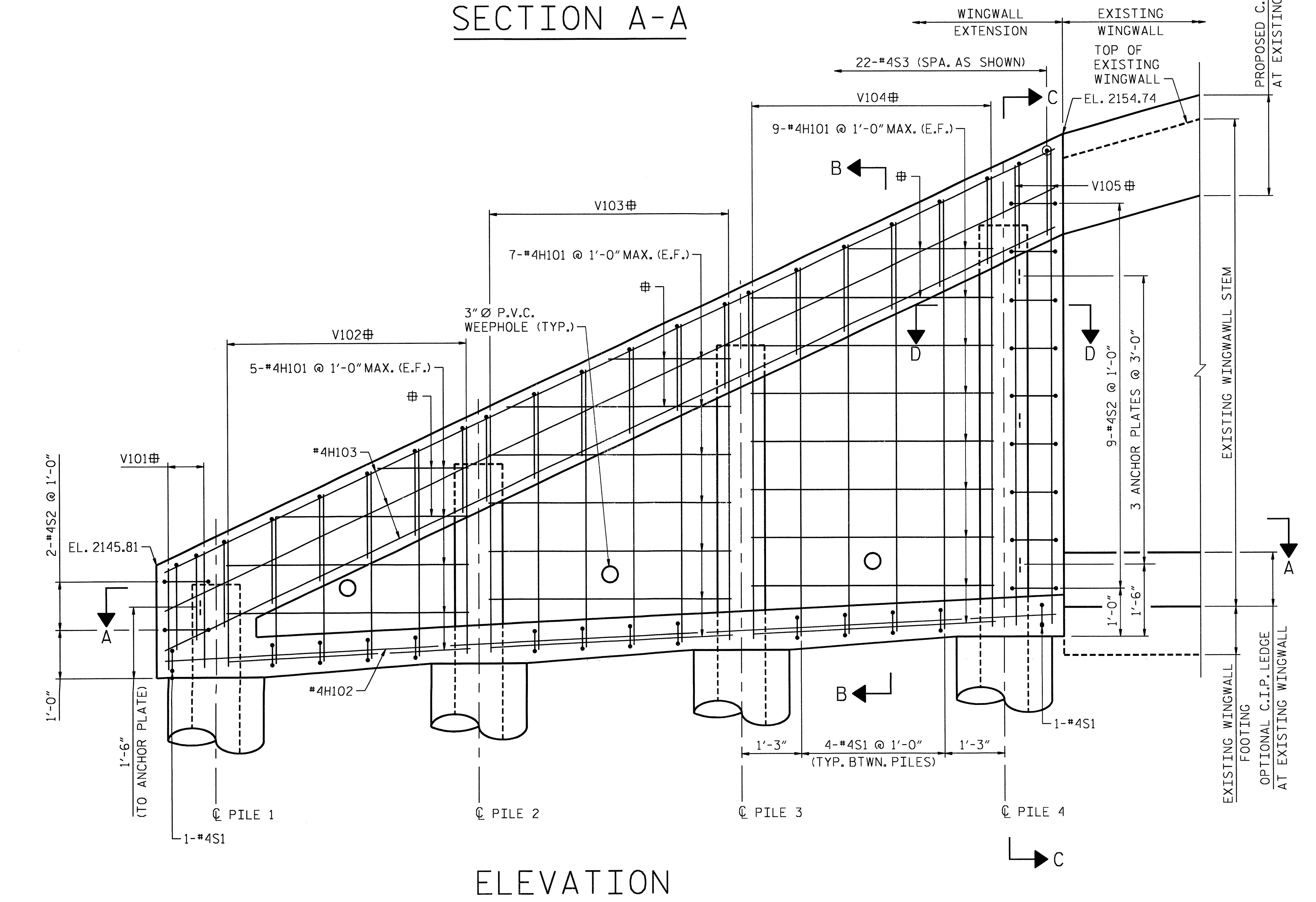

ELEVATION

"V" BARS AND "H" BARS TO BE FIELD CUT AS NECESSARY

NOTES

- FOR GENERAL NOTES, SEE SHEET "GENERAL NOTES AND TOTAL BILL OF MATERIAL".
- FOR SECTIONS C-C AND D-D, SEE SHEET "WINGWALL EXTENSION DETAILS".
- VENEER ANCHORS AND FENCING ALONG TOP OF EXISTING AND PROPOSED WINGWALL EXTENSION NOT SHOWN. FOR DETAILS, SEE "AESTHETIC TREATMENTS" SHEETS.
- FOR PROPOSED C.I.P. COPING AND OPTIONAL C.I.P. LEDGE AT EXISTING WINGWALL, SEE "AESTHETIC TREATMENTS" SHEETS.
- FOR BILL OF MATERIALS SEE SHEET "BILL OF MATERIAL (C.I.P. CONCRETE CONSTRUCTION)".

PILE DATA FOR WINGWALL EXTENSION

PILE NO.	PILE STATION	OFFSET TO PILE FLANGE	PILE SIZE	PILE LENGTH	TOP OF CONC. SHAFT EL.	CUTOFF EL.	PILE TIP EL.
1	11+02.25	*	HP12x53	5.917	2143.49	2145.40	2139.49
2	11+07.75	*	HP12x53	12.250	2143.76	2148.01	2135.76
3	11+13.25	*	HP12x53	18.583	2144.03	2150.61	2132.03
4	11+18.75	*	HP12x53	20.917	2144.30	2153.21	2132.30

* LOCATE PILES SUCH THAT THE THE ROADSIDE FACE OF THE PILE FLANGE IS ALIGNED WITH AND PARALLEL TO THE ROADSIDE FACE OF THE EXISTING WINGWALL STEM.

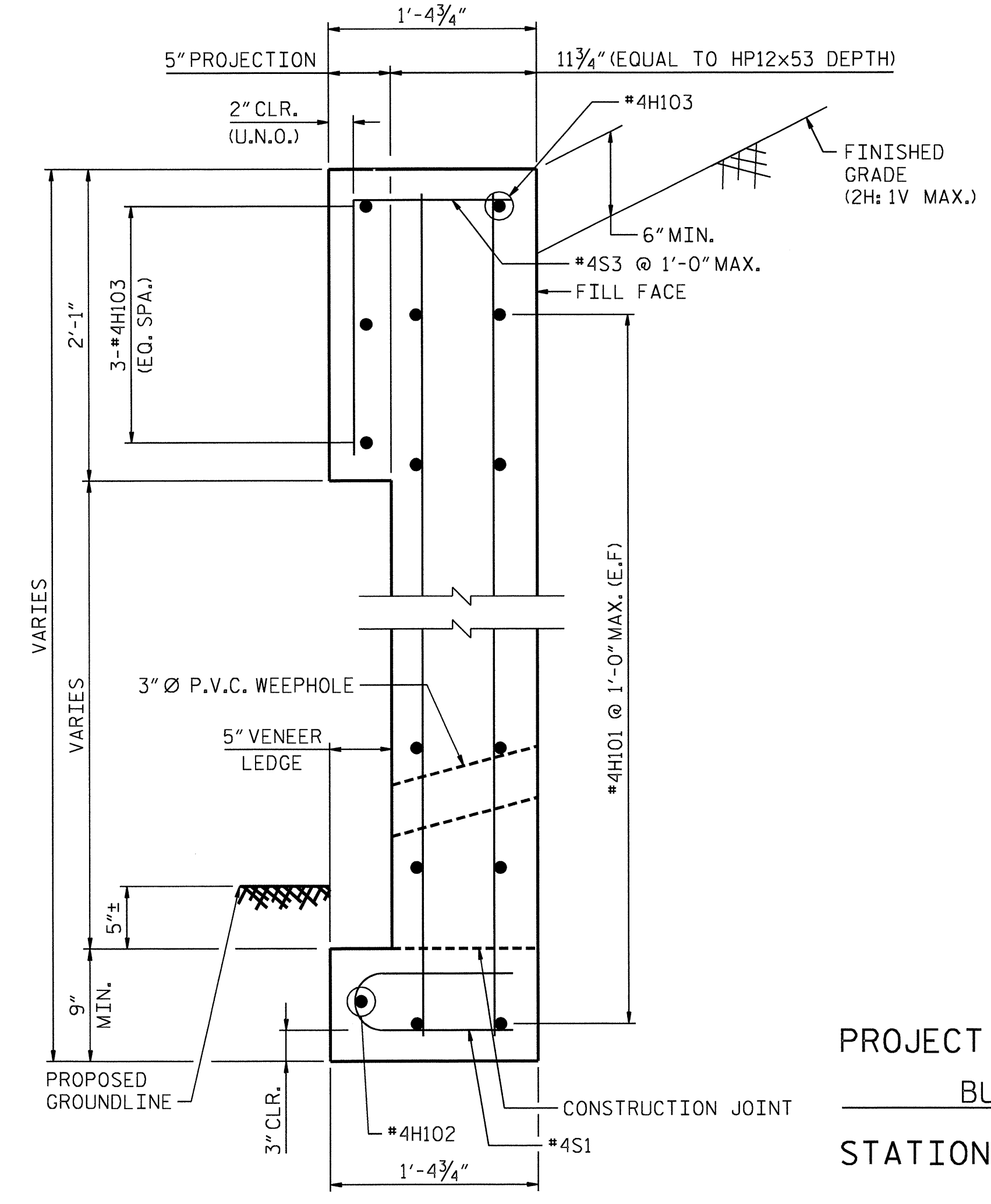

SECTION B-B

PROJECT NO. U-4014
 BUNCOMBE COUNTY
 STATION: _____



STATE OF NORTH CAROLINA
 DEPARTMENT OF TRANSPORTATION
 RALEIGH

SOUTHWEST WINGWALL EXTENSION

REVISIONS						SHEET NO. 5-25
NO.	BY:	DATE:	NO.	BY:	DATE:	
1			3			TOTAL SHEETS 30
2			4			

HDR HDR Engineering, Inc. of the Carolinas
 3733 National Drive, Suite 207 Raleigh, N.C. 27612
 N.C.B.E.L.S. License Number: F-0116

PLOT DRIVER: NCDOT_pdf_mono_eng_50.plt
 USER: msells
 CHECKED BY: J. TAYLOR
 DATE: 9/7/2012
 FILE: North Carolina Dept. of Transportation\NCDOT_U_4014_McDowell_Strip\13.00_CAD\U-4014_Structures\U4014_SD_EXT-SW_01.dgn

DRAWN BY: M. SELLS
 CHECKED BY: J. TAYLOR
 DATE: 05/12
 DATE: 05/12

PLOT DRIVER: NCDOT_pdf_mono_eng_50.plt
 USER: msells
 DATE: 9/7/2012
 FILE: North Carolina Dept. of Transportation\NCDOT_U_4014_Medowell_Strip\1300_CAD\U-4014_Structures\U4014_SD_EXT-SE-01.dgn

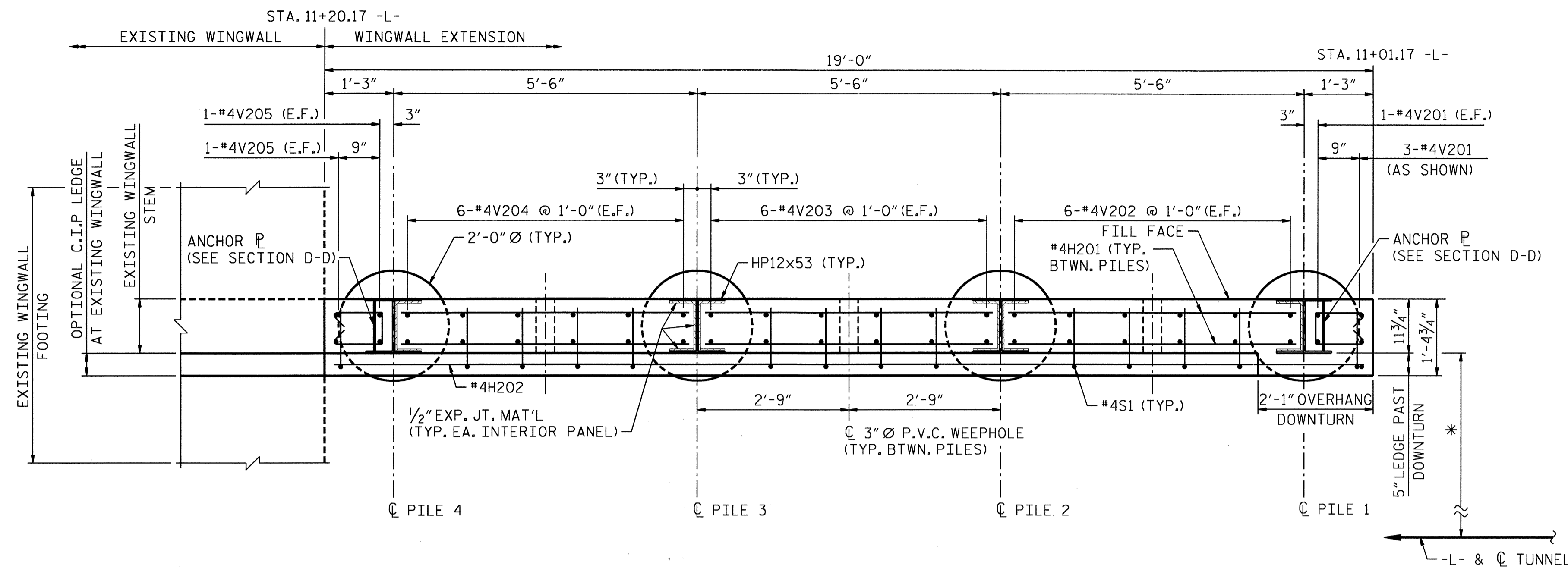

SECTION A-A

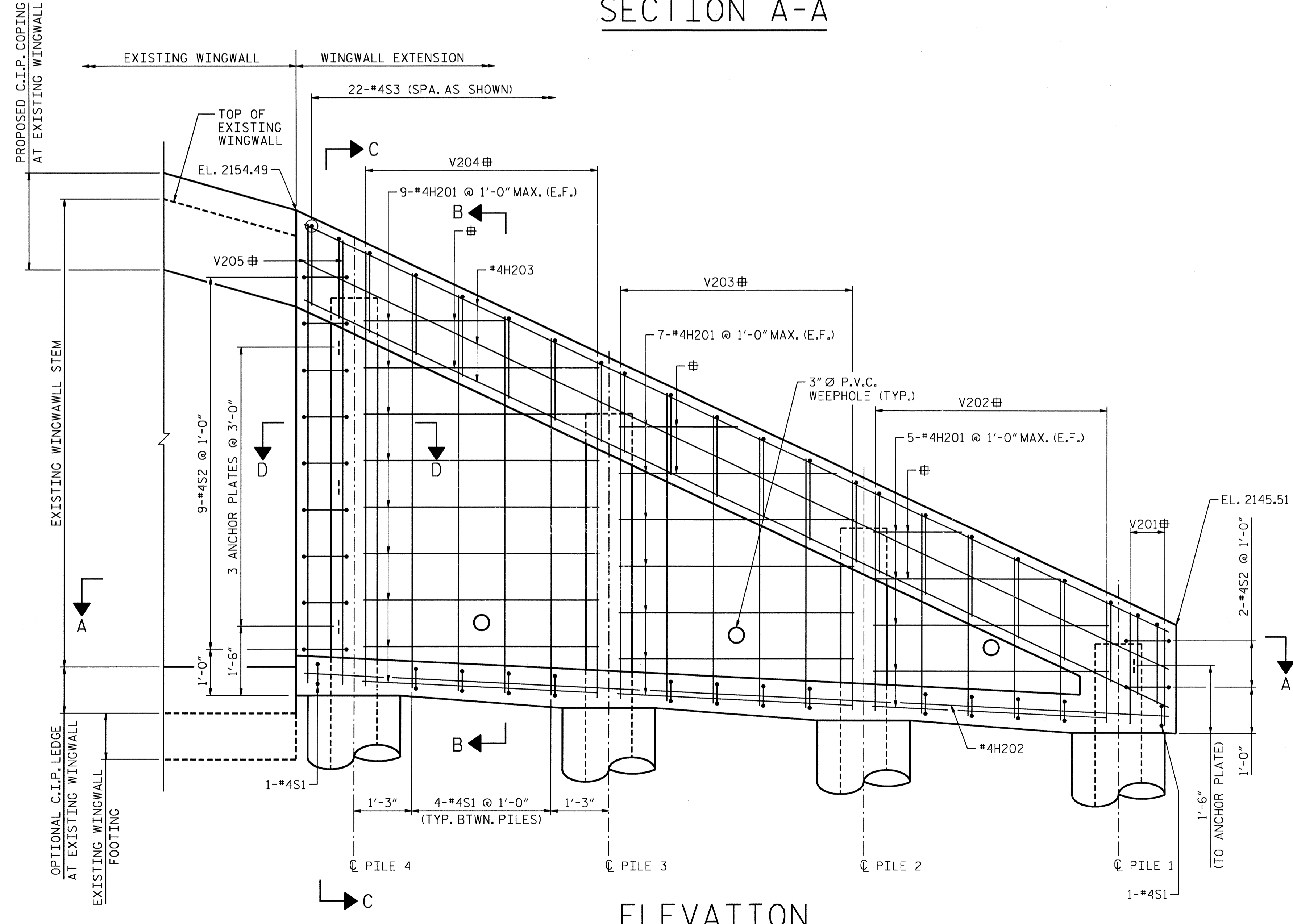

ELEVATION

"V" BARS AND "H" BARS TO BE FIELD CUT AS NECESSARY

NOTES

- FOR GENERAL NOTES, SEE SHEET "GENERAL NOTES AND TOTAL BILL OF MATERIAL".
- FOR SECTIONS C-C AND D-D, SEE SHEET "WINGWALL EXTENSION DETAILS".
- VENEER ANCHORS AND FENCING ALONG TOP OF EXISTING AND PROPOSED WINGWALL EXTENSION NOT SHOWN. FOR DETAILS, SEE "AESTHETIC TREATMENTS" SHEETS.
- FOR PROPOSED C.I.P. COPING AND OPTIONAL C.I.P. LEDGE AT EXISTING WINGWALL, SEE "AESTHETIC TREATMENTS" SHEETS.
- FOR BILL OF MATERIALS SEE SHEET "BILL OF MATERIAL (C.I.P. CONCRETE CONSTRUCTION)".

PILE DATA FOR WINGWALL EXTENSION							
PILE NO.	PILE STATION	OFFSET TO PILE FLANGE	PILE SIZE	PILE LENGTH	TOP OF CONC. SHAFT EL.	CUTOFF EL.	PILE TIP EL.
1	11+02.42	*	HP12x53	5.917	2143.19	2145.10	2139.19
2	11+07.92	*	HP12x53	12.250	2143.50	2147.75	2135.50
3	11+13.42	*	HP12x53	18.500	2143.80	2150.30	2131.80
4	11+18.92	*	HP12x53	20.833	2144.11	2152.95	2127.11

* LOCATE PILES SUCH THAT THE THE ROADSIDE FACE OF THE PILE FLANGE IS ALIGNED WITH AND PARALLEL TO THE ROADSIDE FACE OF THE EXISTING WINGWALL STEM.

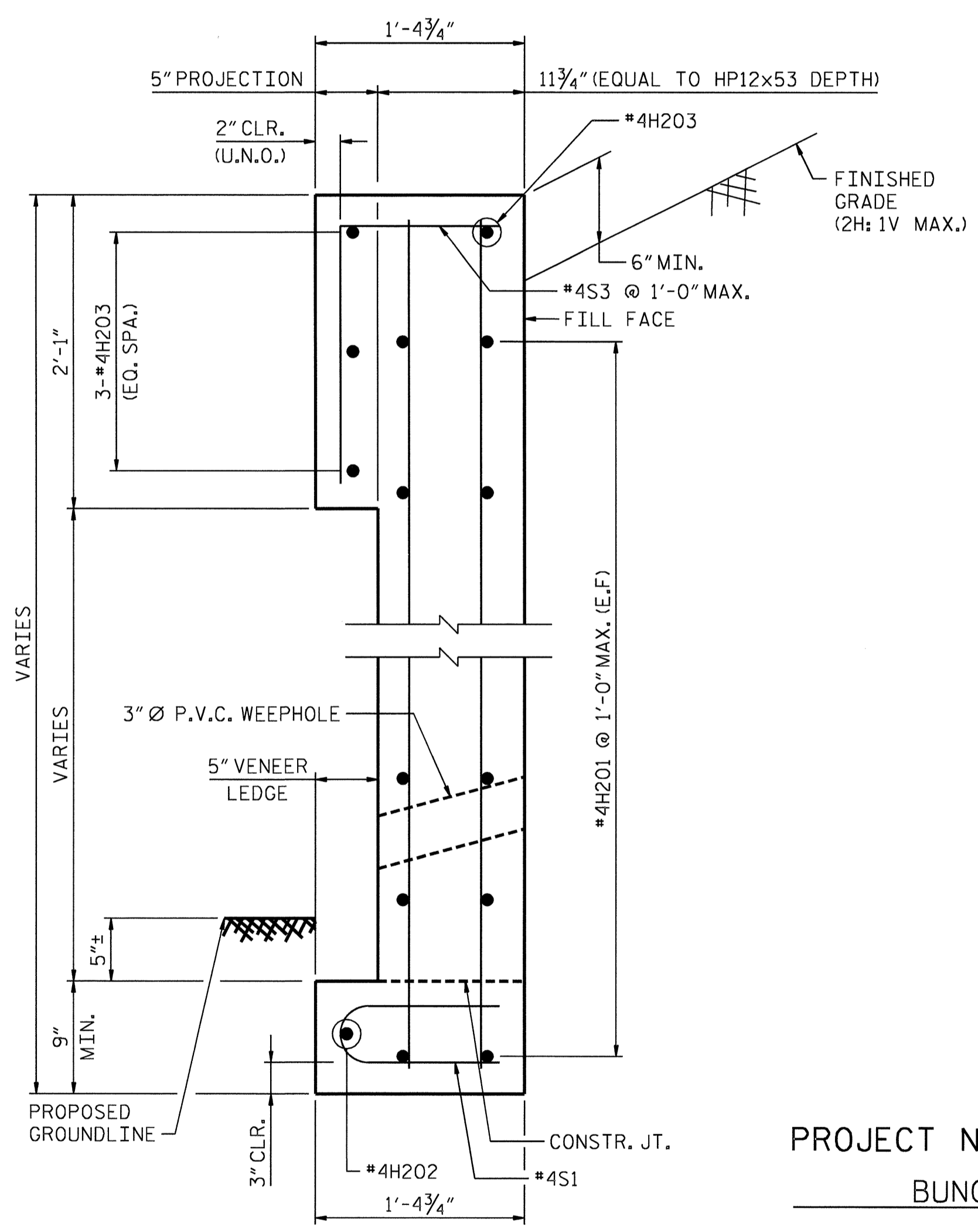

SECTION B-B

PROJECT NO. U-4014
 BUNCOMBE COUNTY
 STATION: _____



STATE OF NORTH CAROLINA
 DEPARTMENT OF TRANSPORTATION
 RALEIGH

SOUTHEAST WINGWALL EXTENSION

DRAWN BY: M. SELLS DATE: 05/12
 CHECKED BY: J. TAYLOR DATE: 05/12

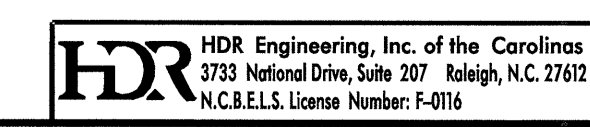

REVISIONS					
NO.	BY:	DATE:	NO.	BY:	DATE:
1			3		
2			4		

SHEET NO. S-26
 TOTAL SHEETS 30

PLOT DRIVER: NCDOT_pdf_mono_eng_50.ppt
 USER: msells
 DATE: 9/7/2012
 TIME: 1:45:33 PM
 FILE: North Carolina Dept. of Transportation\NCDOT_U_4014_McDowell\Street\13.00_CAD\U-4014_Structures\U4014_SD_EXT-NW_01.dgn

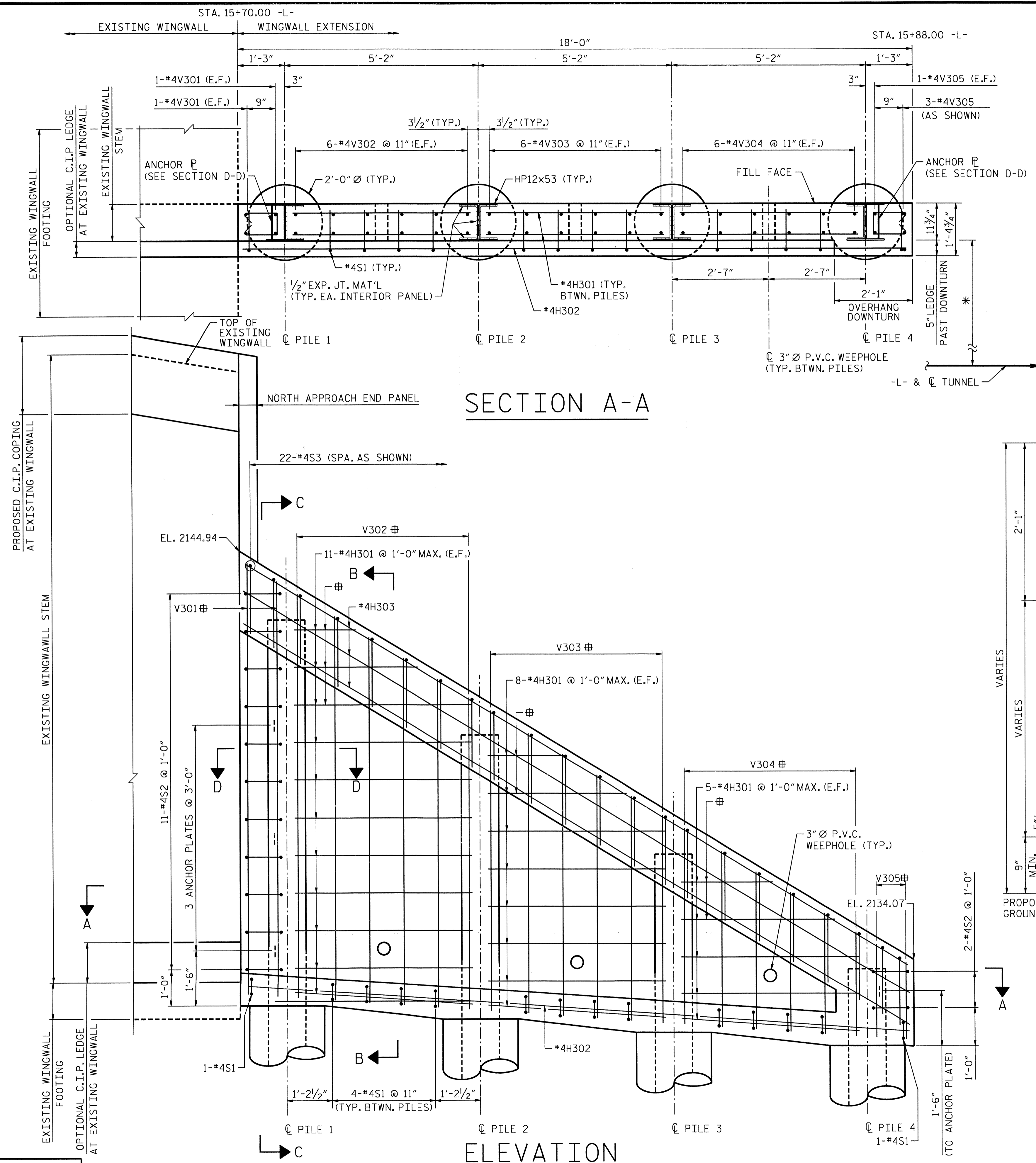

NOTES

- FOR GENERAL NOTES, SEE SHEET "GENERAL NOTES AND TOTAL BILL OF MATERIAL".
- FOR SECTIONS C-C AND D-D, SEE SHEET "WINGWALL EXTENSION DETAILS".
- VENEER ANCHORS AND FENCING ALONG TOP OF EXISTING AND PROPOSED WINGWALL EXTENSION NOT SHOWN. FOR DETAILS, SEE "AESTHETIC TREATMENTS" SHEETS.
- FOR PROPOSED C.I.P. COPING AND OPTIONAL C.I.P. LEDGE AT EXISTING WINGWALL, SEE SHEET "AESTHETIC TREATMENTS" SHEETS.
- FOR BILL OF MATERIALS SEE SHEET "BILL OF MATERIAL (C.I.P. CONCRETE CONSTRUCTION)".

PILE DATA FOR WINGWALL EXTENSION

PILE NO.	PILE STATION	OFFSET TO PILE FLANGE	PILE SIZE	PILE LENGTH	TOP OF CONC. SHAFT EL.	CUTOFF EL.	PILE TIP EL.
1	15+71.25	*	HP12x53	20.417	2132.83	2143.24	2122.83
2	15+76.42	*	HP12x53	17.167	2132.47	2140.13	2122.97
3	15+81.58	*	HP12x53	11.917	2132.11	2137.03	2125.11
4	15+86.75	*	HP12x53	6.083	2131.75	2133.83	2127.75

* LOCATE PILES SUCH THAT THE THE ROADSIDE FACE OF THE PILE FLANGE IS ALIGNED WITH AND PARALLEL TO THE ROADSIDE FACE OF THE EXISTING WINGWALL STEM.

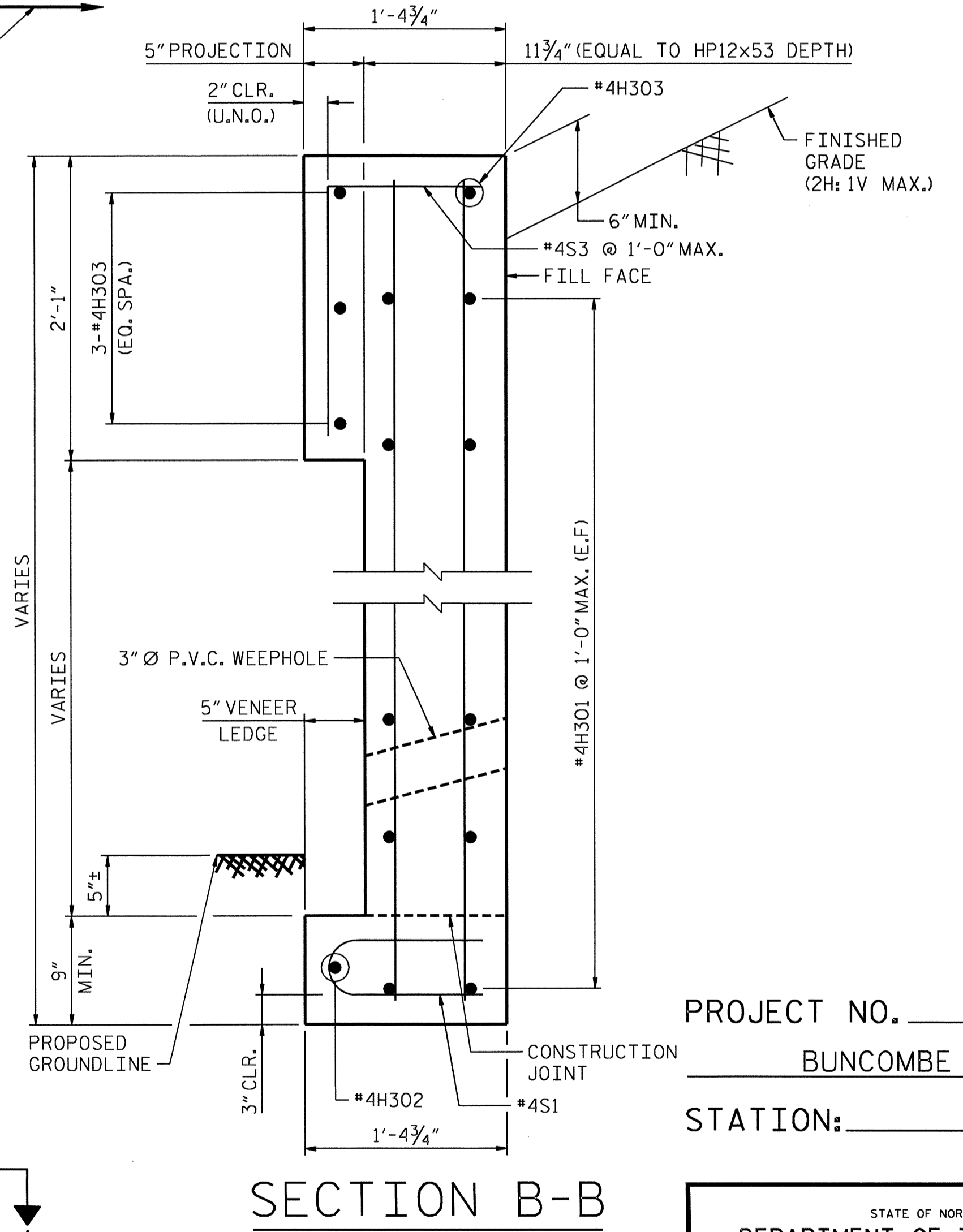

PROJECT NO. U-4014
 BUNCOMBE COUNTY
 STATION: _____



STATE OF NORTH CAROLINA
 DEPARTMENT OF TRANSPORTATION
 RALEIGH

NORTHWEST WINGWALL EXTENSION

REVISIONS						SHEET NO. S-27
NO.	BY:	DATE:	NO.	BY:	DATE:	
1			3			TOTAL SHEETS 30
2			4			

DRAWN BY: M. SELLS DATE: 05/12
 CHECKED BY: J. TAYLOR DATE: 05/12

"V" BARS AND HI BARS TO BE FIELD CUT AS NECESSARY

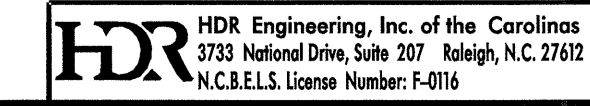

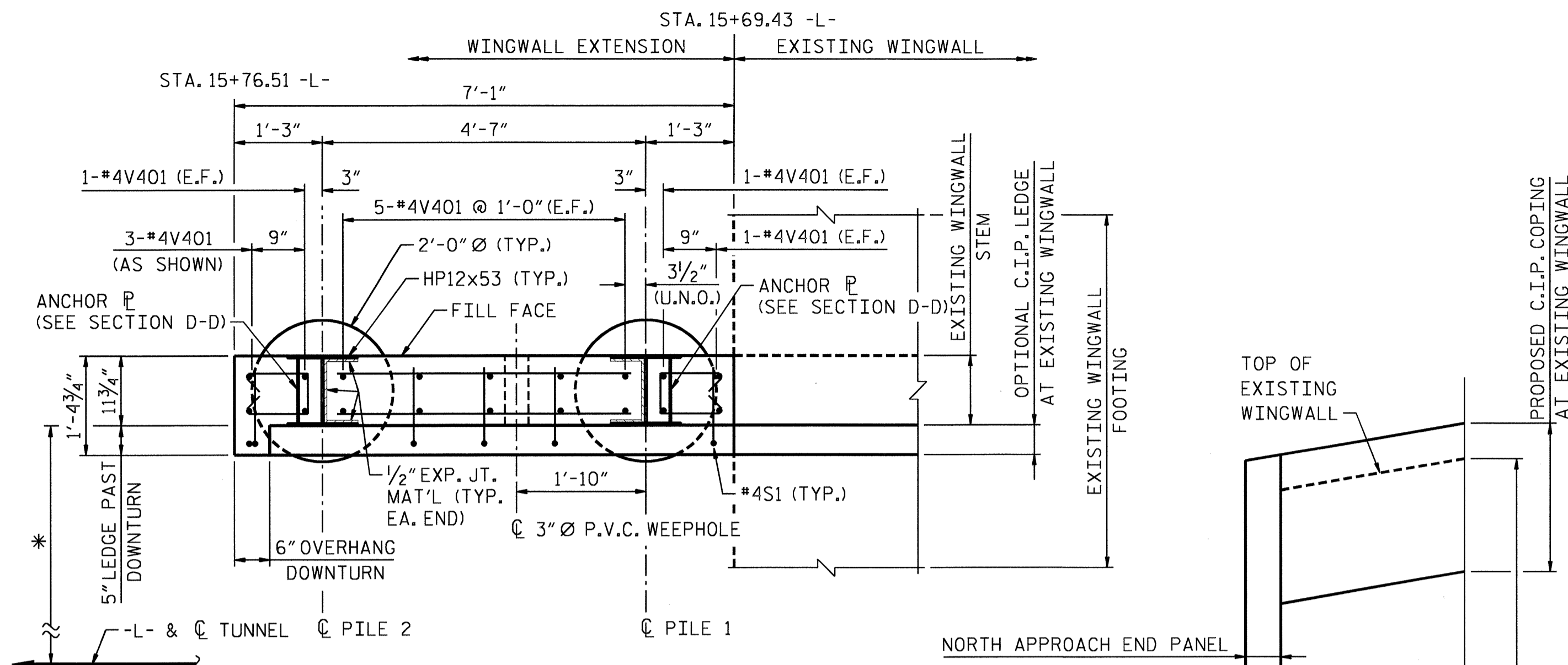

SECTION A-A

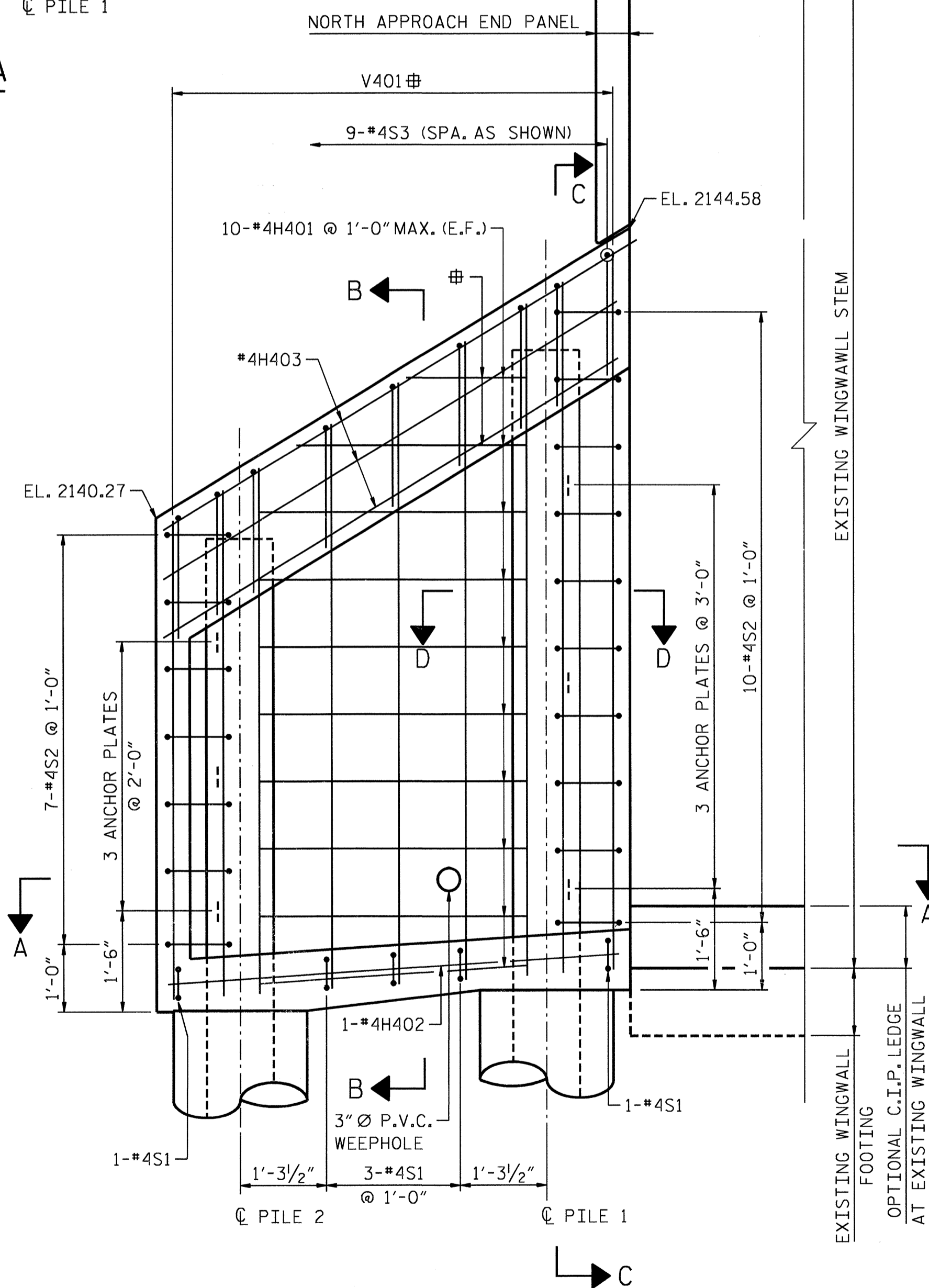

ELEVATION

"V" AND "H" BARS TO BE FIELD CUT AS NECESSARY

NOTES

- FOR GENERAL NOTES, SEE SHEET "GENERAL NOTES AND TOTAL BILL OF MATERIAL".
- FOR SECTIONS C-C AND D-D, SEE SHEET "WINGWALL EXTENSION DETAILS".
- VENEER ANCHORS AND FENCING ALONG TOP OF EXISTING AND PROPOSED WINGWALL EXTENSION NOT SHOWN. FOR DETAILS, SEE "AESTHETIC TREATMENTS" SHEETS.
- FOR PROPOSED C.I.P. COPING AND OPTIONAL C.I.P. LEDGE AT EXISTING WINGWALL, SEE "AESTHETIC TREATMENTS" SHEETS.
- FOR BILL OF MATERIALS SEE SHEET "BILL OF MATERIAL (C.I.P. CONCRETE CONSTRUCTION)".

PILE DATA FOR WINGWALL EXTENSION							
PILE NO.	PILE STATION	OFFSET TO PILE FLANGE	PILE SIZE	PILE LENGTH	TOP OF CONC. SHAFT EL.	CUTOFF EL.	PILE TIP EL.
1	15+70.68	*	HP12x53	17.583	2133.26	2142.85	2125.26
2	15+75.26	*	HP12x53	15.083	2132.96	2140.04	2124.96

* LOCATE PILES SUCH THAT THE THE ROADSIDE FACE OF THE PILE FLANGE IS ALIGNED WITH AND PARALLEL TO THE ROADSIDE FACE OF THE EXISTING WINGWALL STEM.

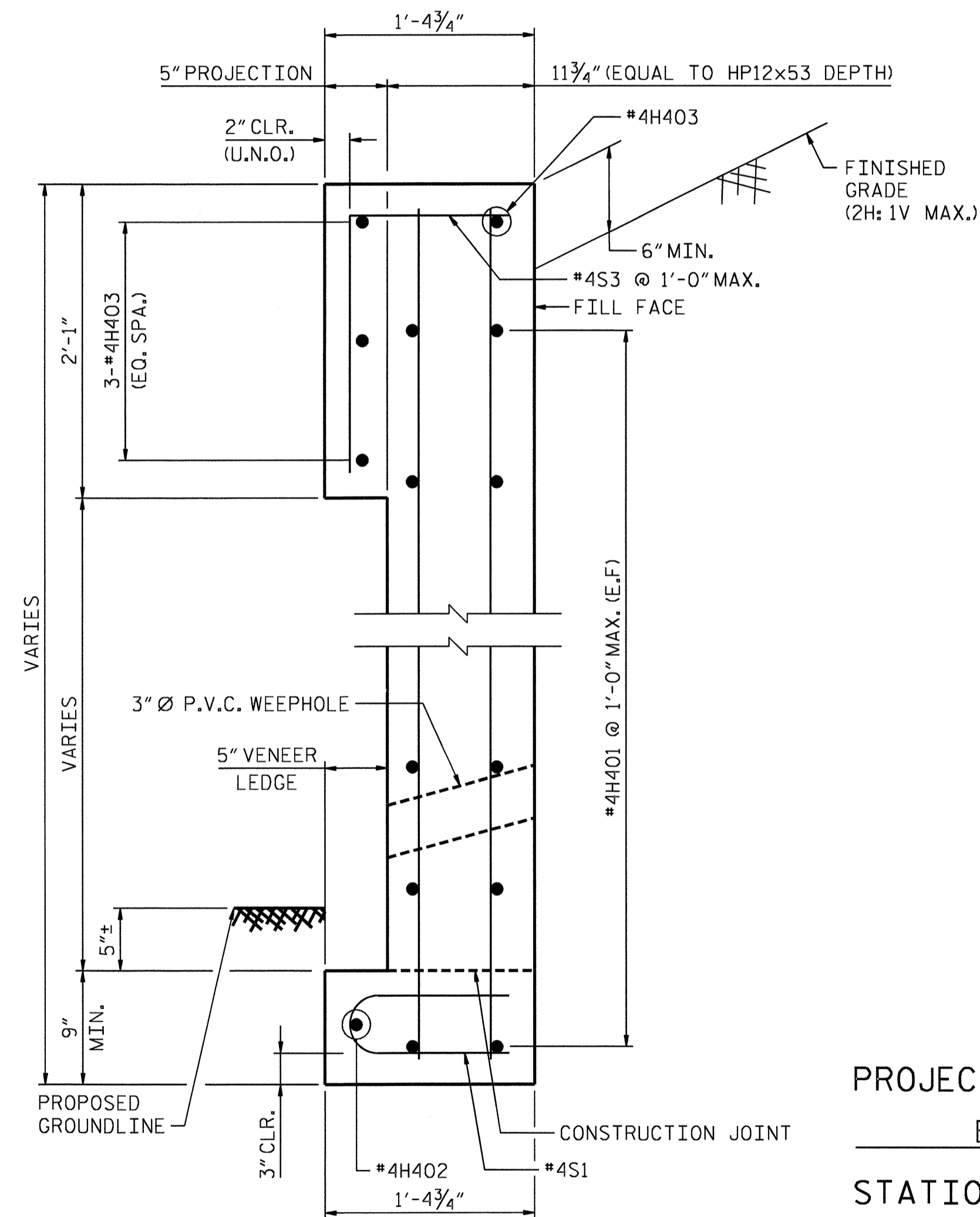

SECTION B-B

PROJECT NO. U-4014
 BUNCOMBE COUNTY
 STATION: _____



STATE OF NORTH CAROLINA
 DEPARTMENT OF TRANSPORTATION
 RALEIGH
 NORTHEAST
 WINGWALL
 EXTENSION

DRAWN BY: M. SELLS DATE: 05/12
 CHECKED BY: J. TAYLOR DATE: 05/12

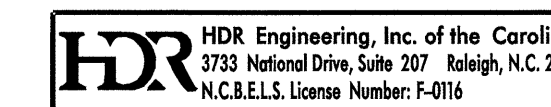

REVISIONS						SHEET NO. 5-28	TOTAL SHEETS 30
NO.	BY:	DATE:	NO.	BY:	DATE:		
1			3				
2			4				

PLOT DRIVER: NCD001.pdf_mono.eng_50.pht
 USER: msells
 DATE: 9/7/2012
 FILE: North Carolina Dept of Transportation\NCD001_U-4014_McDowell_Street\13.00_CAD\U-4014\Structures\U4014_SD_EXT-NE.01.dgn

NOTES
 FOR GENERAL NOTES, SEE SHEET "GENERAL NOTES AND TOTAL BILL OF MATERIAL".
 FOR BILL OF MATERIALS SEE SHEET "BILL OF MATERIAL (C.I.P. CONCRETE CONSTRUCTION)".

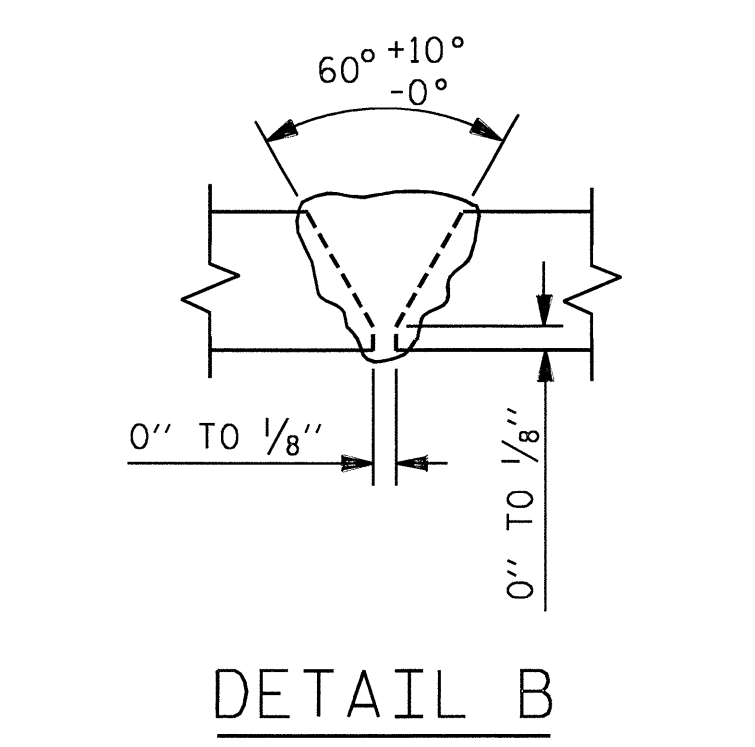
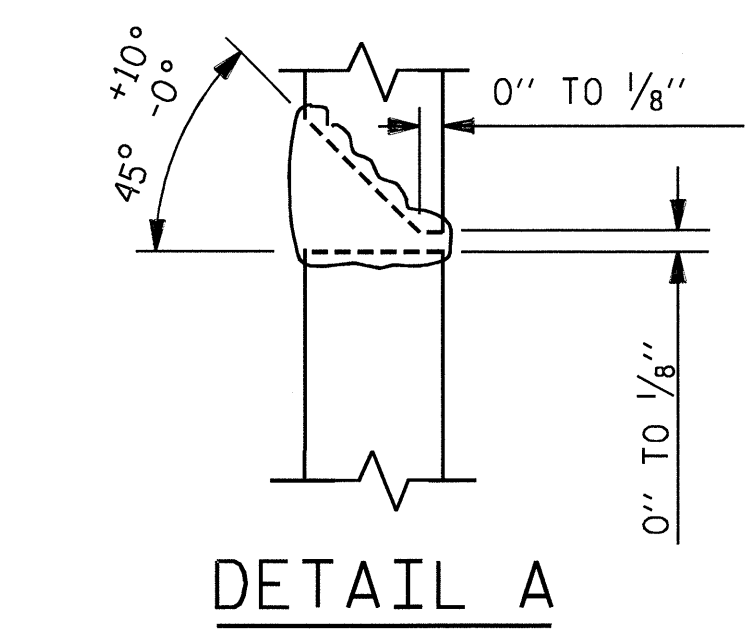
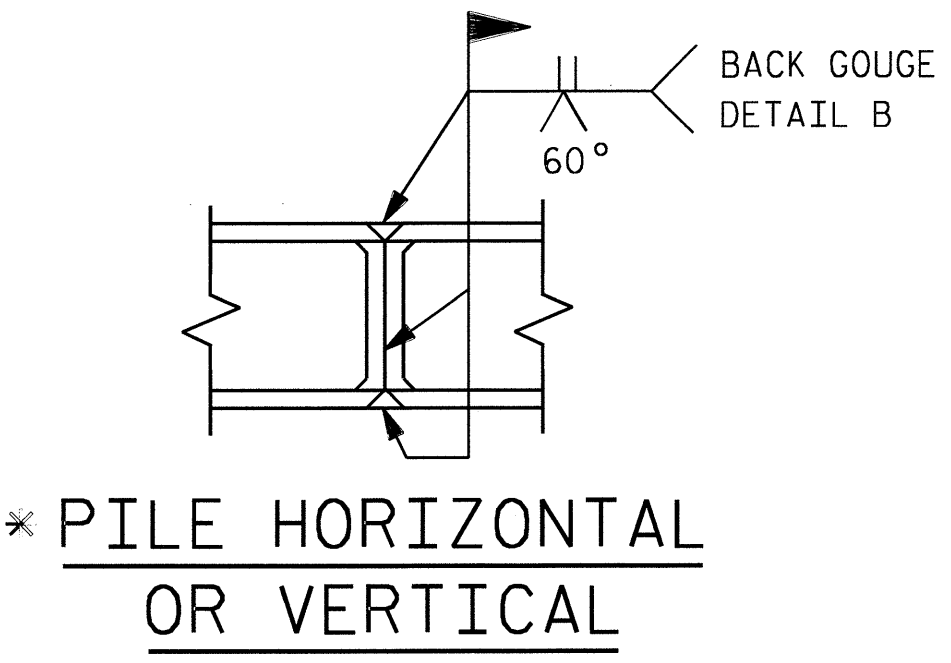
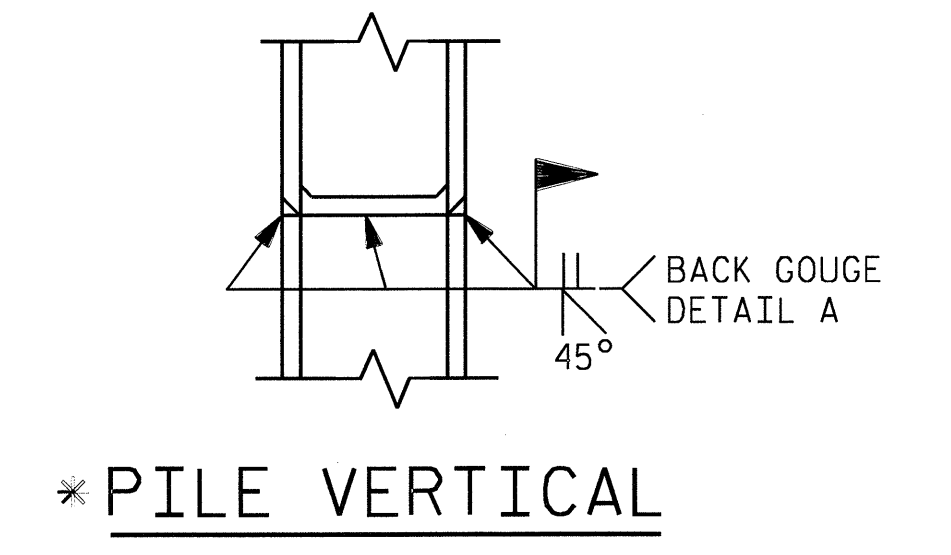

PILE SPLICE DETAILS
 ✕ POSITION OF PILE DURING WELDING.

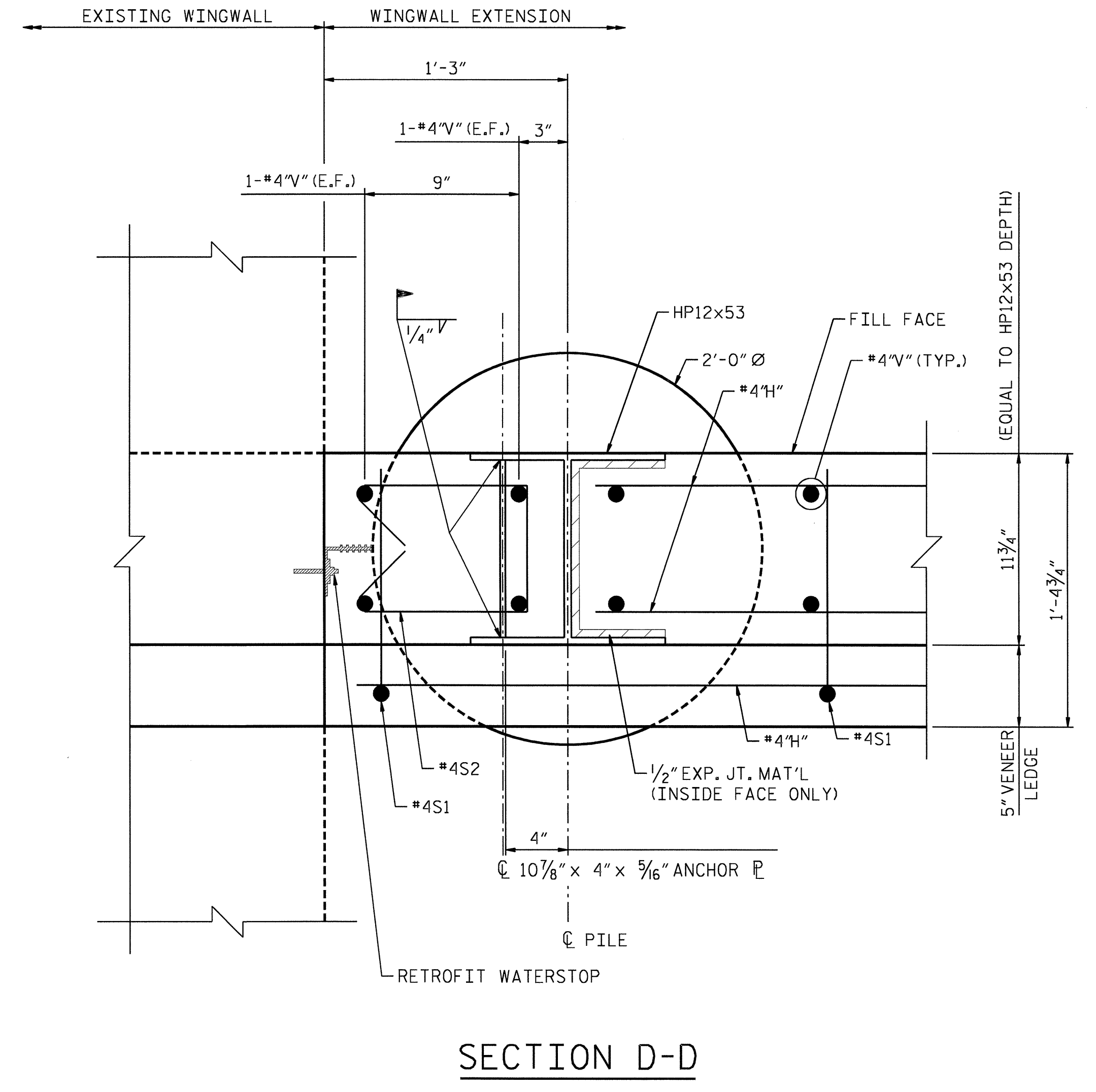
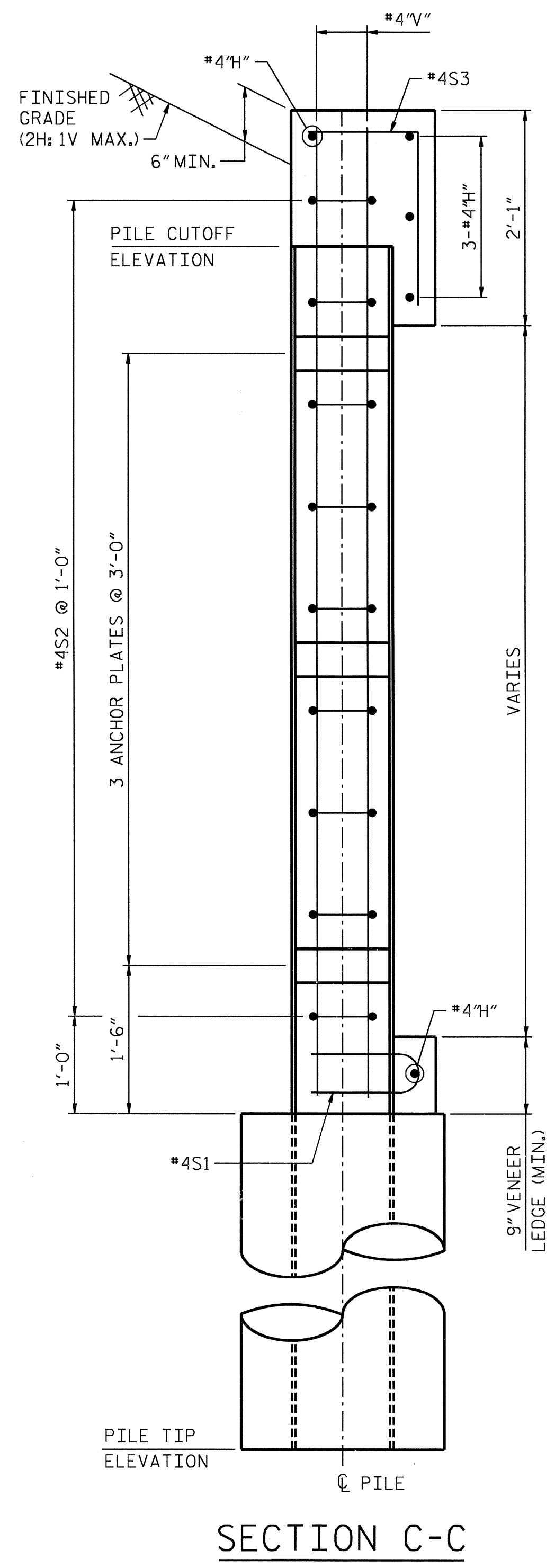

PROJECT NO. U-4014
BUNCOMBE COUNTY
 STATION: _____



STATE OF NORTH CAROLINA
 DEPARTMENT OF TRANSPORTATION
 RALEIGH
WINGWALL EXTENSION DETAILS

REVISIONS						SHEET NO. S-29
NO.	BY:	DATE:	NO.	BY:	DATE:	
1			3			TOTAL SHEETS 30
2			4			

HDR HDR Engineering, Inc. of the Carolinas
 3733 National Drive, Suite 207 Raleigh, NC 27612
 N.C.E.L.S. License Number: F-0116

DRAWN BY : M. SELLS DATE : 07/12
 CHECKED BY : J. TAYLOR DATE : 07/12

PLOT DRIVER: NCD00T_pdf_mono_eng_50.plt
 USER: msells DATE: 9/7/2012
 FILE: North Carolina Dept. of Transportation\NCD00T_U_4014_McDowell\Street\13.00_CAD\U-4014\Structures\U4014_SD_EXT_DET_01.dgn
 PENTABLE: MDT_pen.tbl
 TIME: 1:45:55 PM

**BILL OF MATERIAL
SW WW EXTENSION**

BAR	NO.	SIZE	TYPE	LENGTH	WEIGHT (LBS)
H101	42	# 4	STR	5' - 0"	140
H102	1	# 4	STR	18' - 8"	12
H103	4	# 4	STR	20' - 7"	55
V101	5	# 4	STR	2' - 3"	8
V102	12	# 4	STR	4' - 7"	37
V103	12	# 4	STR	6' - 11"	55
V104	12	# 4	STR	9' - 3"	74
V105	4	# 4	STR	9' - 9"	26
S1	14	# 4	4	2' - 3"	21
S2	11	# 4	5	3' - 2"	23
S3	22	# 4	3	2' - 9"	40

REINFORCING STEEL LBS. 491

CLASS 'A' CONCRETE

* POUR 1-DRILLED-IN PILE SHAFTS	CU.YDS.	4.2
POUR 2-LOWER WING	CU.YDS.	0.7
POUR 3-UPPER WING	CU.YDS.	4.4
TOTAL	CU. YDS.	9.3

**BILL OF MATERIAL
SE WW EXTENSION**

BAR	NO.	SIZE	TYPE	LENGTH	WEIGHT (LBS)
H201	42	# 4	STR	5' - 0"	140
H202	1	# 4	STR	18' - 8"	12
H203	4	# 4	STR	20' - 7"	55
V201	5	# 4	STR	2' - 3"	8
V202	12	# 4	STR	4' - 7"	37
V203	12	# 4	STR	6' - 10"	55
V204	12	# 4	STR	9' - 2"	73
V205	4	# 4	STR	9' - 8"	26
S1	14	# 4	4	2' - 3"	21
S2	11	# 4	5	3' - 2"	23
S3	22	# 4	3	2' - 9"	40

REINFORCING STEEL LBS. 490

CLASS 'A' CONCRETE

* POUR 1-DRILLED-IN PILE SHAFTS	CU.YDS.	4.2
POUR 2-LOWER WING	CU.YDS.	0.7
POUR 3-UPPER WING	CU.YDS.	4.4
TOTAL	CU. YDS.	9.3

**BILL OF MATERIAL
NW WW EXTENSION**

BAR	NO.	SIZE	TYPE	LENGTH	WEIGHT (LBS)
H301	48	# 4	STR	4' - 8"	150
H302	1	# 4	STR	17' - 8"	12
H303	4	# 4	STR	20' - 7"	55
V301	4	# 4	STR	11' - 4"	38
V302	12	# 4	STR	10' - 8"	86
V303	12	# 4	STR	7' - 10"	63
V304	12	# 4	STR	5' - 1"	41
V305	5	# 4	STR	2' - 4"	6
S1	14	# 4	4	2' - 3"	21
S2	13	# 4	5	3' - 2"	27
S3	22	# 4	3	2' - 9"	40

REINFORCING STEEL LBS. 539

CLASS 'A' CONCRETE

* POUR 1-DRILLED-IN PILE SHAFTS	CU.YDS.	3.5
POUR 2-LOWER WING	CU.YDS.	0.7
POUR 3-UPPER WING	CU.YDS.	4.7
TOTAL	CU. YDS.	8.9

**BILL OF MATERIAL
NE WW EXTENSION**

BAR	NO.	SIZE	TYPE	LENGTH	WEIGHT (LBS)
H401	20	# 4	STR	4' - 1"	55
H402	1	# 4	STR	6' - 9"	5
H403	4	# 4	STR	7' - 10"	21
V401	19	# 4	STR	10' - 6"	133
S1	5	# 4	4	2' - 3"	8
S2	17	# 4	5	3' - 2"	36
S3	9	# 4	3	2' - 9"	17

REINFORCING STEEL LBS. 275

CLASS 'A' CONCRETE

* POUR 1-DRILLED-IN PILE SHAFTS	CU.YDS.	1.9
POUR 2-LOWER WING	CU.YDS.	0.3
POUR 3-UPPER WING	CU.YDS.	2.4
TOTAL	CU. YDS.	4.6

* FOR DRILLED-IN PILES, USE CLASS 'A' CONCRETE THAT MEETS NCDOT STANDARD SPECIFICATION ARTICLE 1000-4 EXCEPT AS MODIFIED IN NCDOT STANDARD SPECIFICATION ARTICLE 450-2.

**BILL OF MATERIAL
COPING & PANELS**

BAR	NO.	SIZE	TYPE	LENGTH	WEIGHT (LBS)
A1	16	# 5	STR	42' - 2"	704
A2	16	# 5	STR	42' - 2"	704
A3	24	# 5	STR	41' - 9"	1045
A4	24	# 5	STR	41' - 6"	1039
A5	16	# 5	STR	23' - 7"	394
A6	8	# 5	STR	20' - 0"	167
A7	8	# 5	STR	16' - 5"	137
A8	8	# 5	STR	8' - 10"	74
A9	8	# 5	STR	3' - 2"	26
A10	8	# 5	2	8' - 10"	74
A11	2	# 4	STR	1' - 8"	2
A12	12	# 4	STR	3' - 3"	26
A13	6	# 4	STR	2' - 1"	8
A14	10	# 4	STR	1' - 6"	10

REINFORCING STEEL LBS. 6319

CLASS 'A' CONCRETE

SW WW COPING	CU.YDS.	7.9
SE WW COPING	CU.YDS.	7.9
NW WW COPING	CU.YDS.	11.7
NE WW COPING	CU.YDS.	11.6
PORTAL COPING	CU.YDS.	8.4
PORTAL-TO-WINGWALL TRANSITIONS	CU.YDS.	0.6
TOTAL	CU.YDS.	48.5

**BILL OF MATERIAL
END BLOCKS**

BAR	NO.	SIZE	TYPE	LENGTH	WEIGHT (LBS)
A16	8	# 4	STR	4' - 8"	25
D4	24	# 4	3	1' - 4"	21

REINFORCING STEEL LBS. 46

CLASS 'A' CONCRETE

END BLOCK (4 UNITS)	CU.YDS.	0.3
---------------------	---------	-----

**BILL OF MATERIAL
LUMINAIRE SUPPORT BLOCKS**

BAR	NO.	SIZE	TYPE	LENGTH	WEIGHT (LBS)
B1	481	# 4	1	5' - 5"	1740
B2	4	# 4	1	5' - 1"	14
B3	4	# 4	1	4' - 7"	12
B4	4	# 4	1	4' - 3"	11
B5	4	# 4	1	3' - 11"	10
B6	4	# 4	1	3' - 7"	10
B7	4	# 4	1	3' - 5"	9
B8	4	# 4	1	3' - 3"	9
B9	4	# 4	1	3' - 1"	8
B10	12	# 4	3	2' - 8"	21
B11	8	# 4	3	3' - 9"	20
B12	8	# 4	3	3' - 3"	17
B13	4	# 4	3	1' - 7"	4

REINFORCING STEEL LBS. 52

CLASS 'A' CONCRETE

LUMINAIRE SUPPORT BLOCKS (10 UNITS)	CU.YDS.	0.3
-------------------------------------	---------	-----

**BILL OF MATERIAL
CORBELS**

BAR	NO.	SIZE	TYPE	LENGTH	WEIGHT (LBS)
A15	18	# 4	STR	25' - 0"	301
B15	28	# 4	STR	2' - 3"	42
B16	8	# 4	STR	7' - 7"	41
D2	114	# 4	3	1' - 11"	146
D3	48	# 4	STR	1' - 3"	40
D6	114	# 4	3	2' - 10"	216

REINFORCING STEEL LBS. 786

CLASS 'A' CONCRETE

NORTH CORBEL	CU.YDS.	3.7
SOUTH CORBEL	CU.YDS.	3.7
TOTAL	CU.YDS.	7.4

**ESTIMATED QUANTITIES
OPTIONAL VENEER LEDGE AT
EXISTING WINGWALLS**

REINFORCING STEEL	LBS.	1800
CLASS 'A' CONCRETE	CU. YDS.	10.0

NOTE: SUBSURFACE GEOMETRY OF EXISTING WINGWALLS UNKNOWN. AS NOTED ON "AESTHETIC TREATMENTS (3 OF 6)", THE CONTRACTOR MAY AT HIS DISCRETION INSTALL A VENEER LEDGE. THE ABOVE ESTIMATED QUANTITIES ASSUME AN AVERAGE LEDGE HEIGHT OF 1'-6".

BAR TYPES

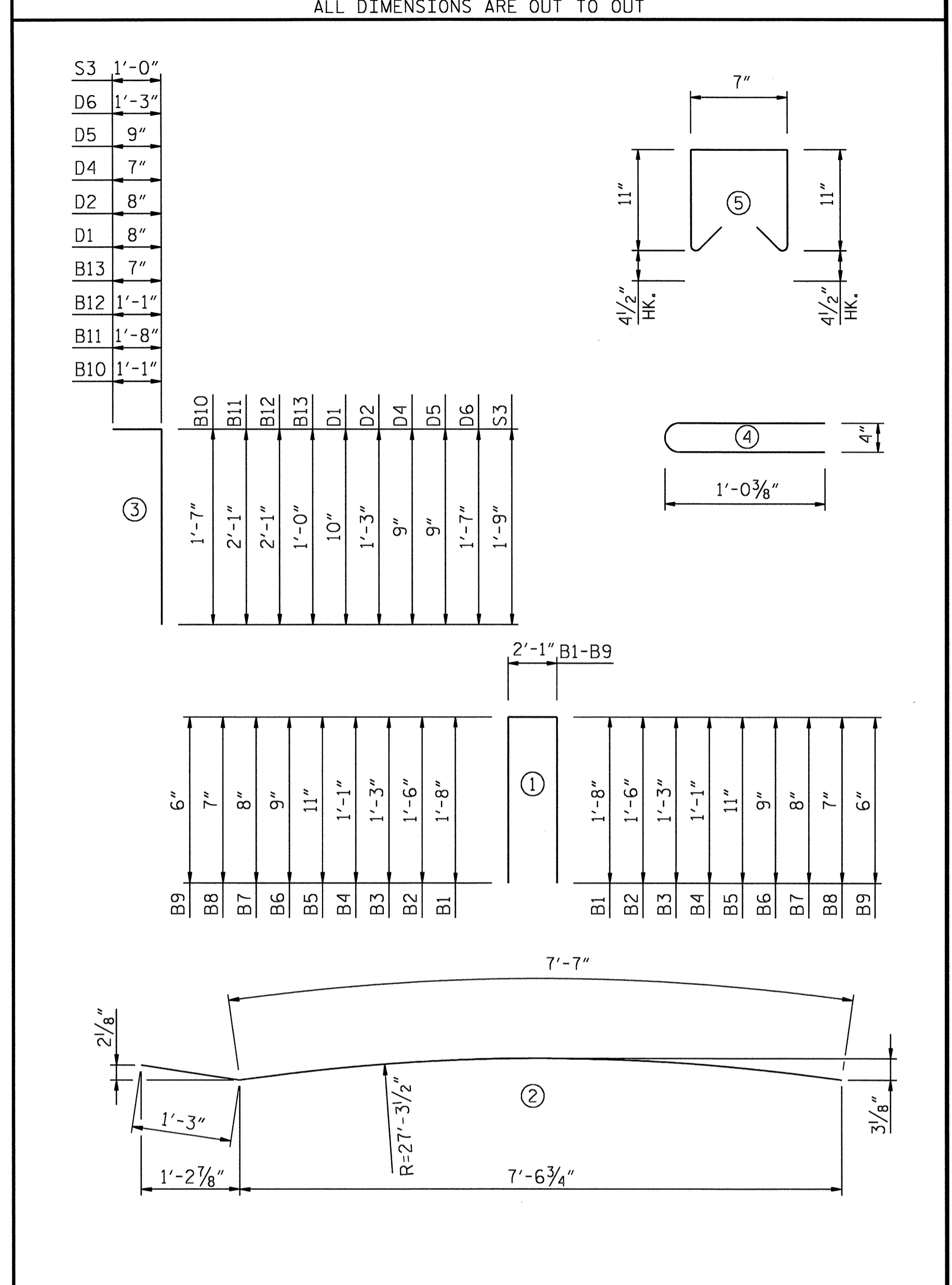

PROJECT NO. U-4014
BUNCOMBE COUNTY
 STATION: _____



STATE OF NORTH CAROLINA
 DEPARTMENT OF TRANSPORTATION
 RALEIGH
**BILL OF MATERIAL
 (C.I.P. CONCRETE
 CONSTRUCTION)**

REVISIONS						SHEET NO. 5-30
NO.	BY:	DATE:	NO.	BY:	DATE:	
1			3			TOTAL SHEETS 30
2			4			

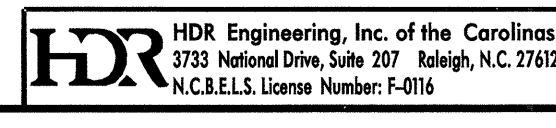

DRAWN BY: M. SELLS DATE: 06/12
 CHECKED BY: J. TAYLOR DATE: 06/12

PLOT DRIVER: NCDOT_pdf_mono_eng_50.plt
 USER: msells DATE: 9/7/2012
 FILE: North Carolina Dept. of Transportation\NCDOT\U-4014_McDowell_Street\13.00_CAD\U-4014_Structures\U4014_S0_CIP-BOM_01.DGN
 PENTABLE: MDT_pen.tbl
 TIME: 1:46:04 PM

PLANS AND DETAILS FOR PROPOSED LIGHTING / ELECTRICAL INSTALLATION

SCOPE OF WORK

PROVIDE TUNNEL AND WINGWALL LIGHTING SYSTEM. INSTALL LED LUMINAIRES, LIGHT CONTROL SYSTEM PANEL AND CIRCUITRY. CIRCUITRY INCLUDES BURIED AND SURFACE MOUNTED RGS CONDUIT.

DESIGN CRITERIA

2005 AASHTO ROADWAY LIGHTING DESIGN GUIDE
 2009 AASHTO STANDARD SPECIFICATIONS FOR STRUCTURAL SUPPORTS FOR HIGHWAY SIGNS, LUMINAIRES, AND TRAFFIC SIGNALS, 5TH EDITION, AND LATEST INTERIM SPECIFICATIONS VALID AT THE TIME OF LETTING
 2011 NATIONAL ELECTRICAL CODE
 2002 AASHTO ROADSIDE DESIGN GUIDE

ROADWAY STANDARDS

THE FOLLOWING ROADWAY ENGLISH STANDARDS AS APPEAR IN "NCDOT ROADWAY STANDARD DRAWINGS", ROADWAY DESIGN UNIT-N.C. DEPARTMENT OF TRANSPORTATION RALEIGH, N.C., DATED JANUARY 2012 ARE APPLICABLE TO THIS PROJECT AND BY REFERENCE HEREBY ARE CONSIDERED A PART OF THESE PLANS:

STD NO.	TITLE
1408D01	LIGHT CONTROL SYSTEM (USE DETAIL SHEETS 1408D01 IN LIEU OF STANDARD DRAWING 1408.01)

ALL WORK SHALL BE IN CONFORMANCE WITH DIVISION 14 OF THE STANDARD SPECIFICATIONS FOR ROADS AND STRUCTURES, DATED JANUARY 2012.

ABBREVIATIONS

BD	BURIED	C	CONDUIT
LT	LIGHT	CKT	CIRCUIT
MH	MOUNTING HEIGHT	N	NEUTRAL
Ø	PHASE	G	GROUND
PVC	PVC SCHEDULE 40 CONDUIT		
RGS	RIGID GALVANIZED STEEL		

PLAN SYMBOL		DESCRIPTION	CONTRACT ITEM
10B	1 #10Ø	1 AWG SIZE 10 CONDUCTOR (BK)	2 - 10 W/G FEEDER CIRCUIT IN 1" CONDUIT
	1 #10N	1 AWG SIZE 10 GROUNDING CONDUCTOR (WH)	
	1 #10G	1 AWG SIZE 10 GROUNDING CONDUCTOR	
	1" RGS	1" RIGID GALVANIZED STEEL CONDUIT	
10B2	1 #10Ø	1 AWG SIZE 10 CONDUCTOR (BK)	2 - 10 W/G FEEDER CIRCUIT IN 1/2" CONDUIT
	1 #10N	1 AWG SIZE 10 GROUNDING CONDUCTOR (WH)	
	1 #10G	1 AWG SIZE 10 GROUNDING CONDUCTOR	
	1/2" RGS	1/2" RIGID GALVANIZED STEEL CONDUIT	
*10B	1 #10Ø	1 AWG SIZE 10 CONDUCTOR (BK)	2 - 10 W/G FEEDER CIRCUIT IN 3/4" FLEX
	1 #10N	1 AWG SIZE 10 GROUNDING CONDUCTOR (WH)	
	1 #10G	1 AWG SIZE 10 GROUNDING CONDUCTOR	
	3/4" LIQUID TIGHT FLEXIBLE METAL CONDUIT		
*10R	1 #10Ø	1 AWG SIZE 10 CONDUCTOR (RED)	2 - 10 W/G FEEDER CIRCUIT IN 3/4" FLEX
	1 #10N	1 AWG SIZE 10 GROUNDING CONDUCTOR (WH)	
	1 #10G	1 AWG SIZE 10 GROUNDING CONDUCTOR	
	3/4" LIQUID TIGHT FLEXIBLE METAL CONDUIT		
10BR	2 #10Ø	2 AWG SIZE 10 CONDUCTOR (BK & RED)	3 - 10 W/G FEEDER CIRCUIT IN 1" CONDUIT
	1 #10N	1 AWG SIZE 10 GROUNDING CONDUCTOR (WH)	
	1 #10G	1 AWG SIZE 10 GROUNDING CONDUCTOR	
	1" RGS	1" RIGID GALVANIZED STEEL CONDUIT	
10BRR	3 #10Ø	3 AWG SIZE 10 CONDUCTOR (BK, BK & RED)	4 - 10 W/G FEEDER CIRCUIT IN 1" CONDUIT
	1 #10N	1 AWG SIZE 10 GROUNDING CONDUCTOR (WH)	
	1 #10G	1 AWG SIZE 10 GROUNDING CONDUCTOR	
	1" RGS	1" RIGID GALVANIZED STEEL CONDUIT	
10BRR	3 #10Ø	3 AWG SIZE 10 CONDUCTOR (BK, RED & RED)	4 - 10 W/G FEEDER CIRCUIT IN 1" CONDUIT
	1 #10N	1 AWG SIZE 10 GROUNDING CONDUCTOR (WH)	
	1 #10G	1 AWG SIZE 10 GROUNDING CONDUCTOR	
	1" RGS	1" RIGID GALVANIZED STEEL CONDUIT	
10BRR2	3 #10Ø	3 AWG SIZE 10 CONDUCTOR (BK, BK & RED)	4 - 10 W/G FEEDER CIRCUIT IN 1/2" CONDUIT
	1 #10N	1 AWG SIZE 10 GROUNDING CONDUCTOR (WH)	
	1 #10G	1 AWG SIZE 10 GROUNDING CONDUCTOR	
	1/2" RGS	1/2" RIGID GALVANIZED STEEL CONDUIT	
10BRR2	3 #10Ø	3 AWG SIZE 10 CONDUCTOR (BK, RED & RED)	4 - 10 W/G FEEDER CIRCUIT IN 1/2" CONDUIT
	1 #10N	1 AWG SIZE 10 GROUNDING CONDUCTOR (WH)	
	1 #10G	1 AWG SIZE 10 GROUNDING CONDUCTOR	
	1/2" RGS	1/2" RIGID GALVANIZED STEEL CONDUIT	

ESTIMATED MATERIALS

QTY	UNIT	DESCRIPTION
28	EA	LED ROADWAY LUMINAIRE
2	EA	LED ROADWAY LUMINAIRE (SPARE TURNED OVER TO NCDOT DIVISION TRAFFIC SERVICE ENGINEER)
2	EA	LED OPTICAL ASSEMBLY AND LED DRIVER FOR LED ROADWAY LUMINAIRE (SPARE TURNED OVER TO NCDOT DIVISION TRAFFIC SERVICE ENGINEER)
18	EA	LUMINAIRE MOUNTING BRACKET - TUNNEL
6	EA	LUMINAIRE MOUNTING BRACKET (STANDARD SIZE) - WINGWALL
4	EA	LUMINAIRE MOUNTING BRACKET (EXTENDED SIZE) - WINGWALL
2	EA	LUMINAIRE MOUNTING BRACKET - TUNNEL (SPARE TURNED OVER TO NCDOT DIVISION TRAFFIC SERVICE ENGINEER)
1	EA	LUMINAIRE MOUNTING BRACKET (STANDARD SIZE) - WINGWALL (SPARE TURNED OVER TO NCDOT DIVISION TRAFFIC SERVICE ENGINEER)
1	EA	LUMINAIRE MOUNTING BRACKET (EXTENDED SIZE) - WINGWALL (SPARE TURNED OVER TO NCDOT DIVISION TRAFFIC SERVICE ENGINEER)
32	EA	GALVANIZED CAST JUCTION BOX W/ BLANK COVER AND GASKET
41	EA	GALVANIZED RAIN TIGHT THREADED 1" CONDUIT HUB
28	EA	GALVANIZED RAIN TIGHT THREADED 3/4" CONDUIT HUB
21	EA	GALVANIZED RAIN TIGHT THREADED 1/2" CONDUIT HUB
420	FT	1/2" RIGID GALVANIZED STEEL CONDUIT
630	FT	1" RIGID GALVANIZED STEEL CONDUIT
70	FT	3/4" LIQUID TIGHT FLEXIBLE METAL CONDUIT
2	EA	1" GALVANIZED CAST IRON SERVICE LB CONDULET FITTING WITH THREADED HUBS
5	EA	1/2" GALVANIZED CAST IRON LB CONDULET FITTING WITH THREADED HUBS
2	EA	1" GALVANIZED CAST IRON LB CONDULET FITTING WITH THREADED HUBS
1	LOT	ZINC RICH PAINT
9	EA	GALVANIZED EXPANSION FITTING FOR 1/2" RIGID GALVANIZED CONDUIT
16	EA	GALVANIZED EXPANSION FITTING FOR 1" RIGID GALVANIZED CONDUIT

LIGHTING FIXTURE SCHEDULE

DESCRIPTION	MANUFACTURER	CATALOG NO.	LAMPS				BALLAST			FIXTURE WATTS	FIXTURE VOLTAGE
			QTY	TYPE	LUMENS	WATTS	QTY	TYPE	WATTS		
LED AREA LUMINAIRE WITH DIE-CAST ALUMINUM HOUSING AND DARK BRONZE FINISH. INTEGRAL OR SEPARATE MOUNTING ARM, NOMINALLY 8-INCHES IN LENGTH. UL LISTED FOR WET LOCATIONS AND MINIMUM RATING OF IP 65. TYPE V OPTICS WITH LED/DRIVER SYSTEM RATED FOR MINIMUM OF 50,000 HOURS AT AMBIENT TEMPERATURE OF 40 DEGREES CELSIUS. LM-79 TESTS AND REPORTS PERFORMED IN ACCORDANCE WITH IESNA STANDARDS.	LITHONIA LIGHTING	AS1 LED 1 63B350/50K SR5 SPA DDBXD	1	LED ASSEMBLY CCT >= 5000K	6,395	-	1	SOLID STATE LED DRIVER	75	75	120
	PHILIPS GARDCO	GL18 1 5 65LA CW BRP	1	LED ASSEMBLY CCT >= 5000K	5,674	-	1	SOLID STATE LED DRIVER	65	65	120
	GE LIGHTING SOLUTIONS	EAMM-A5-N-57-A-1-10-DKB2	1	LED ASSEMBLY CCT >= 5000K	6,800	-	1	SOLID STATE LED DRIVER	100	100	120
	HUBBELL-SPAULDING	CL1-A-30L-5K-5-DB	1	LED ASSEMBLY CCT >= 5000K	5,208	-	1	SOLID STATE LED DRIVER	70	70	120

PROJECT NO. U-4014
BUNCOMBE COUNTY
 STATION: _____



REVISIONS						SHEET NO. U4014-E1
NO.	BY:	DATE:	NO.	BY:	DATE:	
1			3			TOTAL SHEETS 9
2			4			

HDR HDR Engineering, Inc. of the Carolinas
 3733 National Drive, Suite 207 Raleigh, N.C. 27612
 N.C. E.L.S. License Number: F-0116

DRAWN BY: C.L. SHAW DATE: DEC. 10
 CHECKED BY: S.A. QUIN DATE: DEC. 10

PLOT DRIVER: NCDOT...
 FILE: North Carolina Dept. of Transportation\NCDOT\U-4014_McDowell\Street\1300-CAD\U-4014_LightingElectrical\Lighting_Design\Ud014_E1.dgn
 DATE: 9/6/2012
 TIME: 6:47:19 PM

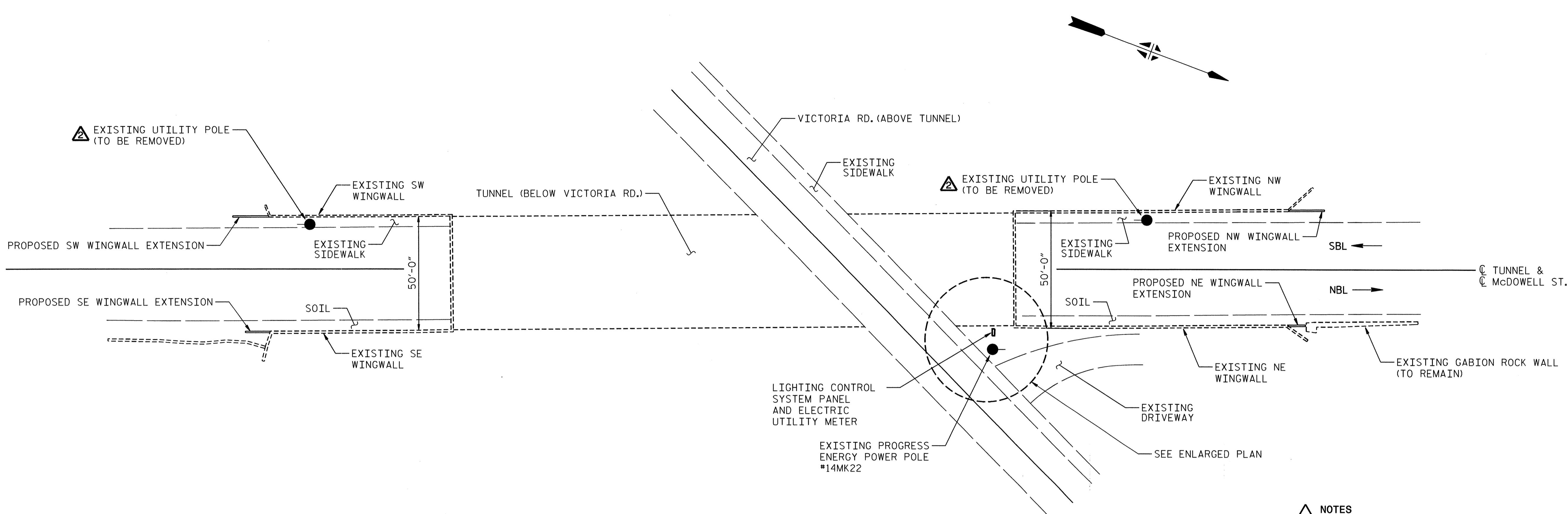

ELECTRICAL SITE PLAN ⚠

- NOTES**
- ⚠ SEE SHEET U4014-01 FOR SITE DIMENSIONS.
 - ⚠ COORDINATE REMOVAL OF EXISTING UTILITY LIGHT POLES WITH PROGRESS ENERGY. CONTACT ROBERT METCALF WITH PROGRESS ENERGY TO REQUEST REMOVAL OF POLES, OFFICE PHONE NUMBER 828-271-3596.
 - ⚠ COORDINATE WITH PROGRESS ENERGY FOR NEW ELECTRICAL SERVICE. SEE NOTE 2 FOR CONTACT INFORMATION.
 - ⚠ PROVIDE 1" GALVANIZED RIGID STEEL CONDUIT FOR CIRCUITRY. INSTALL CONDUITS 30" BELOW GRADE AND TURN UP AT WINGWALL.
 - ⚠ PROVIDE 1" GALVANIZED LB FITTINGS AND 1" GALVANIZED SERVICE LB FITTINGS TO ROUTE CONDUITS UP, OVER AND DOWN WINGWALL. EXTEND CONDUITS TO JUNCTION BOXES LOCATED ON THE NE WINGWALL. SEE SHEET E5 FOR LOCATION OF JUNCTION BOXES.

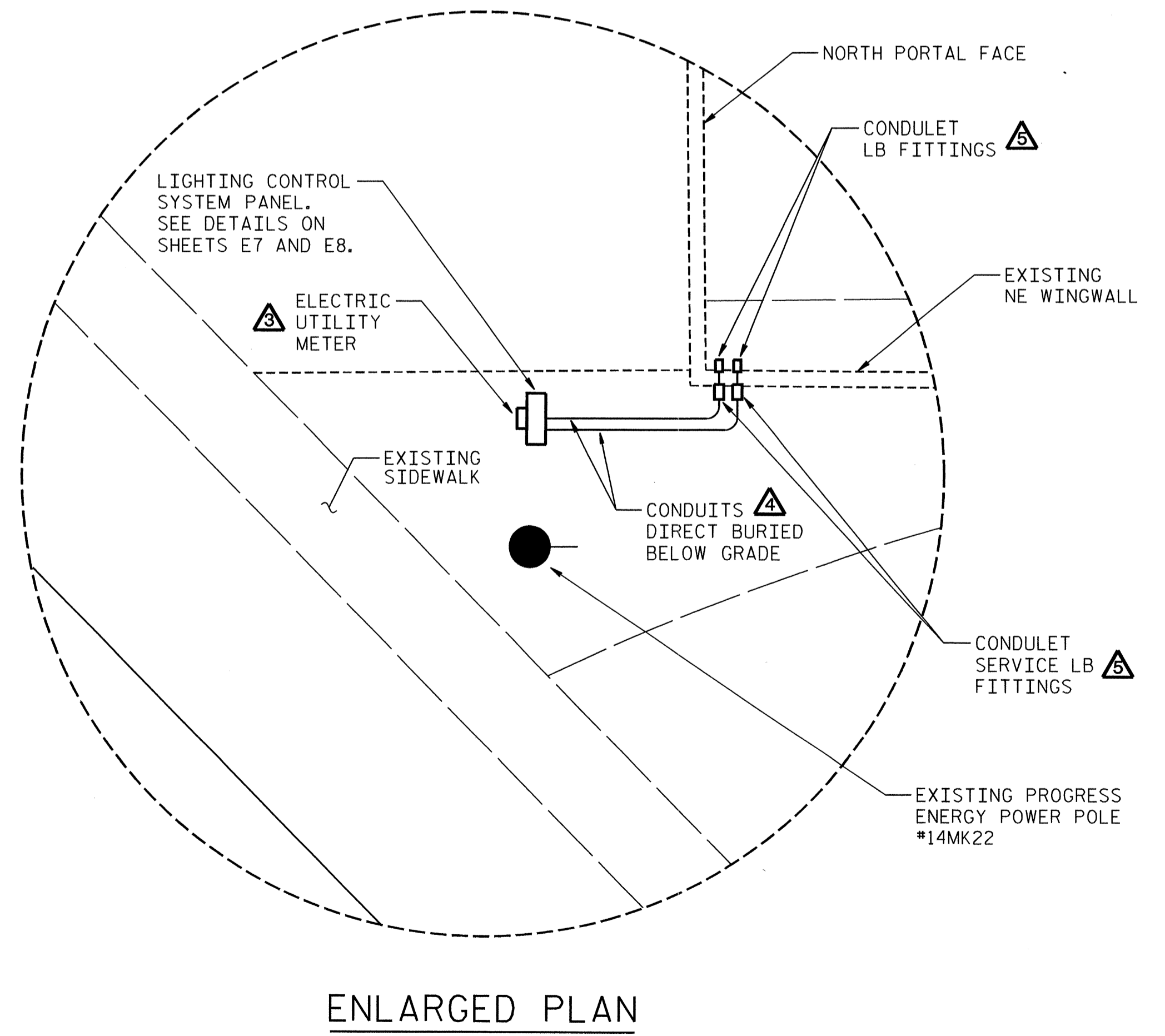

ENLARGED PLAN

PROJECT NO. U-4014
BUNCOMBE COUNTY
 STATION: _____

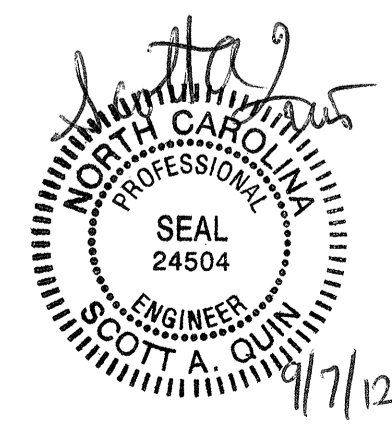

STATE OF NORTH CAROLINA DEPARTMENT OF TRANSPORTATION RALEIGH					
ELECTRICAL SITE PLAN					
REVISIONS					
NO.	BY:	DATE:	NO.	BY:	DATE:
1			3		
2			4		
					SHEET NO. U4014-E2 TOTAL SHEETS 9

DRAWN BY : C.L. SHAW DATE : _____
 CHECKED BY : S.A. QUIN DATE : _____

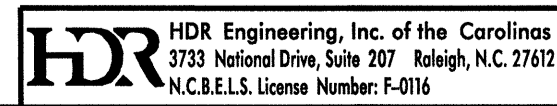

PLOT DRIVER: NCDOT_pdf_mono_eng_50.plt
 USER: awalnwr1 DATE: 9/6/2012
 FILE: North Carolina Dept. of Transportation\NCDOT_U-4014_McDowell_Street\13.00_CAD\U-4014_Lighting\Electrical\Lighting_Design\U4014-E2.dgn

PLOT DRIVER: NCDOT_pdf_mono_eng_50.pht
 USER: dwtwrf1 DATE: 9/6/2012
 FILE: North Carolina Dept. of Transportation\3.00_CAD\U-4014_McDowell_Street\Lighting_Electrical\Lighting_Design\U4014_E3.dgn

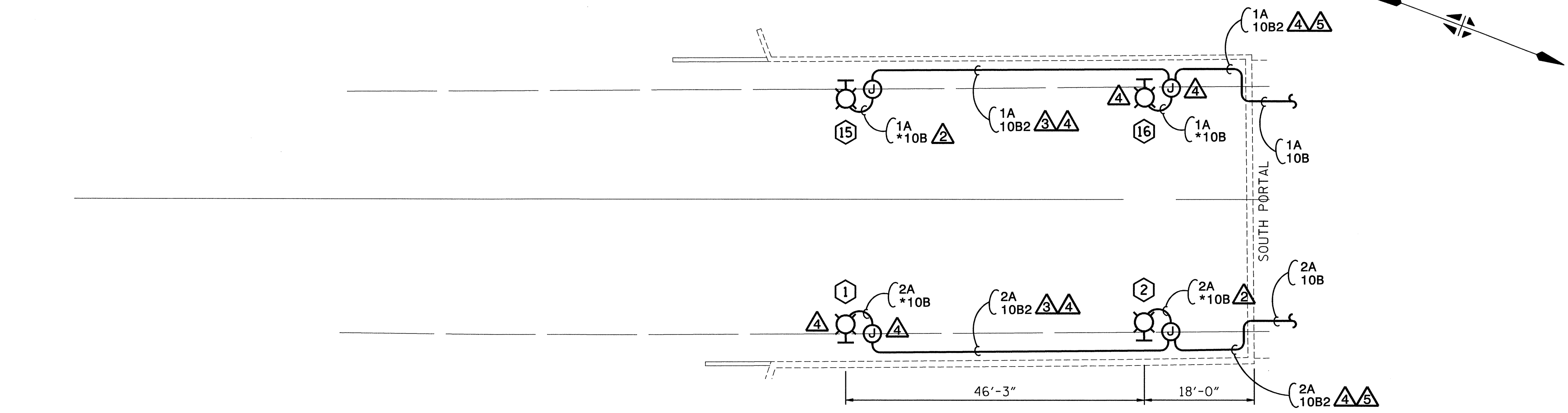

LIGHTING LAYOUT - SOUTH WINGWALLS

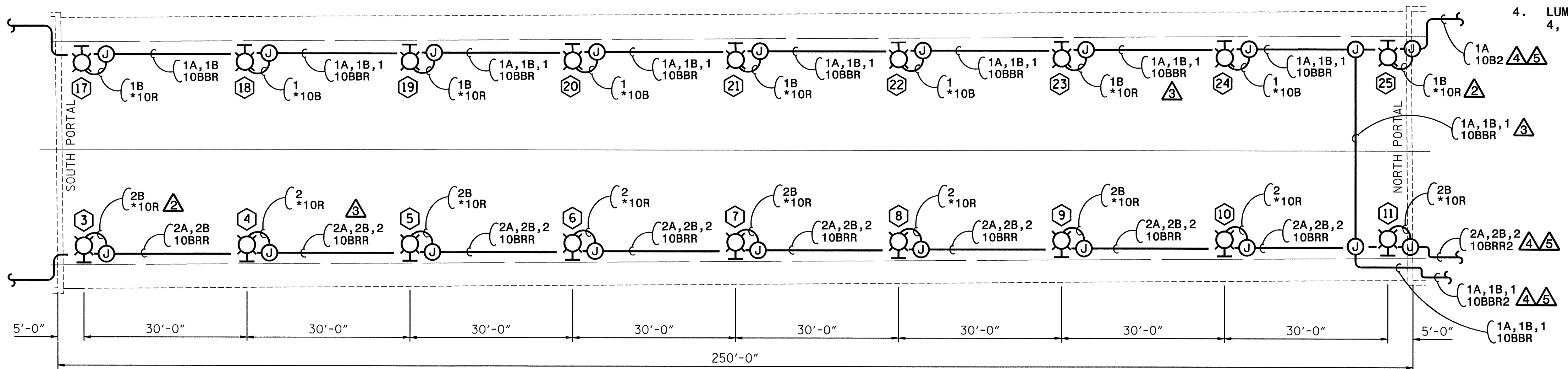

LIGHTING LAYOUT - McDOWELL STREET TUNNEL

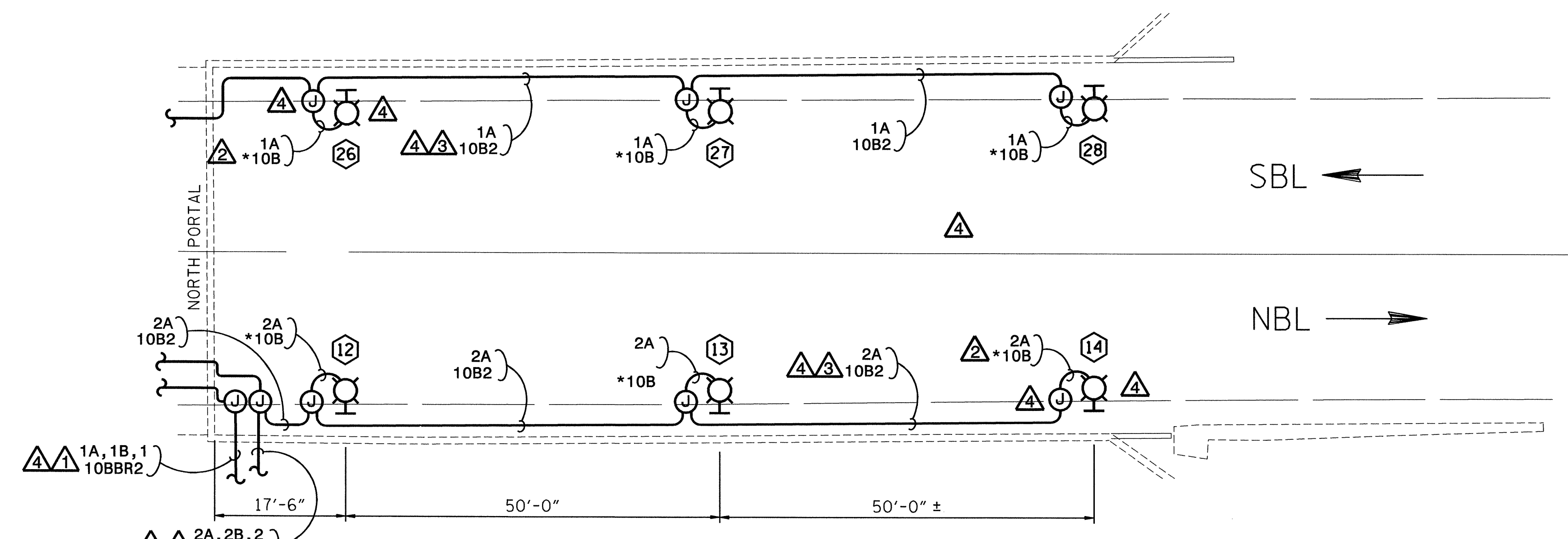

LIGHTING LAYOUT - NORTH WINGWALLS

- NOTES
- △ CONDUITS ROUTED UP WINGWALL TO LIGHTING CONTROL SYSTEM PANEL. SEE ENLARGED PLAN ON SHEET E2 FOR CONTINUATION OF CONDUITS.
 - △ PROVIDE 3/4" LIQUID TIGHT FLEXIBLE METAL CONDUIT FROM JUNCTION BOX TO LED ROADWAY LUMINAIRE, TYPICAL. SEE LUMINAIRE MOUNTING BRACKET DETAILS ON SHEET E9.
 - △ ROUTE 1" RGS CONDUIT ALONG TUNNEL AND 1/2" RGS CONDUIT ALONG WINGWALL AND PORTAL WALL SURFACES, TYPICAL. PROVIDE CONDUIT STRAPS W/BACK FOR SUPPORTING CONDUITS. INSTALL STRAPS @ 5' SPACING, MAXIMUM, AND INSTALL WITHIN 3' OF JUNCTION BOXES AND CONDULETS. PROVIDE EXPANSION FITTINGS IN EACH SECTION OF CONDUIT THAT IS GREATER THAN 20' LONG BETWEEN TERMINALS AT JUNCTION BOXES.
 - △ INSTALL 1/2" RGS CONDUIT BENEATH VENEER AND ON EXISTING WINGWALL AND PORTAL WALL SURFACES, TYPICAL. INSTALL JUNCTION BOXES AND LUMINAIRE ON FACE OF VENEER, TYPICAL. PROVIDE GROUT FILL BEHIND JUNCTION BOXES.
 - △ USE 1/2" LB CONDULET FITTING FOR TRANSITION OF CONDUIT FROM TUNNEL SURFACE TO BENEATH VENEER ON PORTAL FACE.

- GENERAL NOTES
1. LED ROADWAY LUMINAIRE, JUNCTION BOXES AND RIGID CONDUITS ARE SHOWN DIAGRAMMATICALLY. REFER TO ELEVATIONS ON SHEETS E4, E5 & E6 FOR EXACT LOCATIONS OF LUMINAIRE, JUNCTION BOXES AND CONDUITS.
 2. LUMINAIRE SWITCHED OFF BY PHOTOCELL AT NIGHT: 3, 5, 7, 9, 11, 17, 19, 21, 23, 25
 3. LUMINAIRE SWITCHED ON BY PHOTOCELL AT NIGHT: 1, 2, 12, 13, 14, 15, 16, 26, 27, 28
 4. LUMINAIRE NOT SWITCHED BY PHOTOCELL (ALWAYS ON): 4, 6, 8, 10, 18, 20, 22, 24

PROJECT NO. U-4014
 BUNCOMBE COUNTY
 STATION: _____

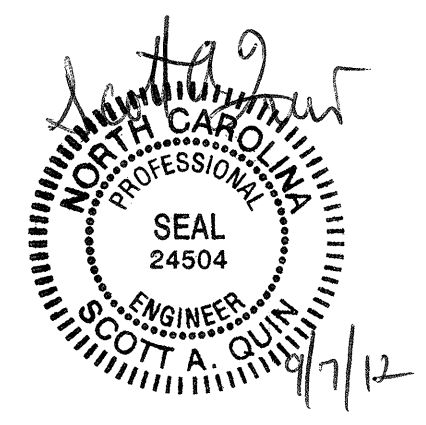

STATE OF NORTH CAROLINA
 DEPARTMENT OF TRANSPORTATION
 RALEIGH
 GENERAL DRAWING
 TUNNEL ELECTRICAL
 LIGHTING PLAN

DRAWN BY: C.L. SHAW DATE: DEC. 10
 CHECKED BY: S.A. QUINN DATE: DEC. 10

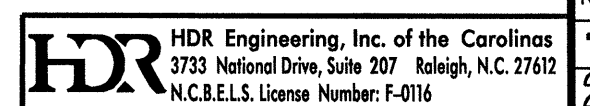

REVISIONS						SHEET NO. U4014-E3	
NO.	BY:	DATE:	NO.	BY:	DATE:	TOTAL SHEETS 9	
1			3				
2			4				

PLOT DRIVER: NCDOT_pdf_memo_eng_50.plt
 USER: dwdnwr1
 DATE: 9/6/2012
 TIME: 6:47:41 PM
 FILE: North Carolina Dept. of Transportation\NCDOT_U-4014_McDowell_Street_V13.00.CAD\U-4014_Lighting\Electrical\Lighting_Design\U4014-E4.dgn

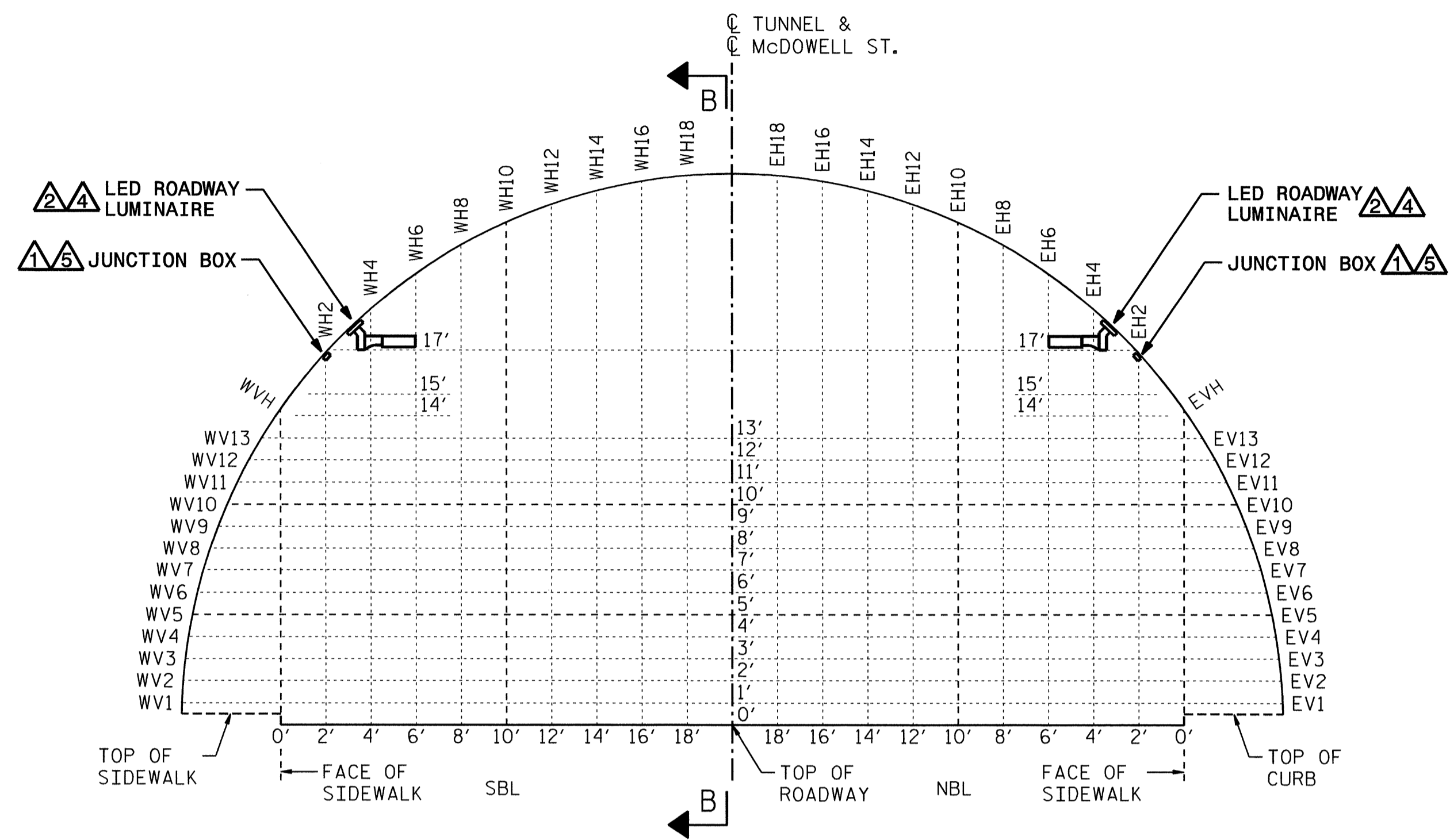

VIEW A-A

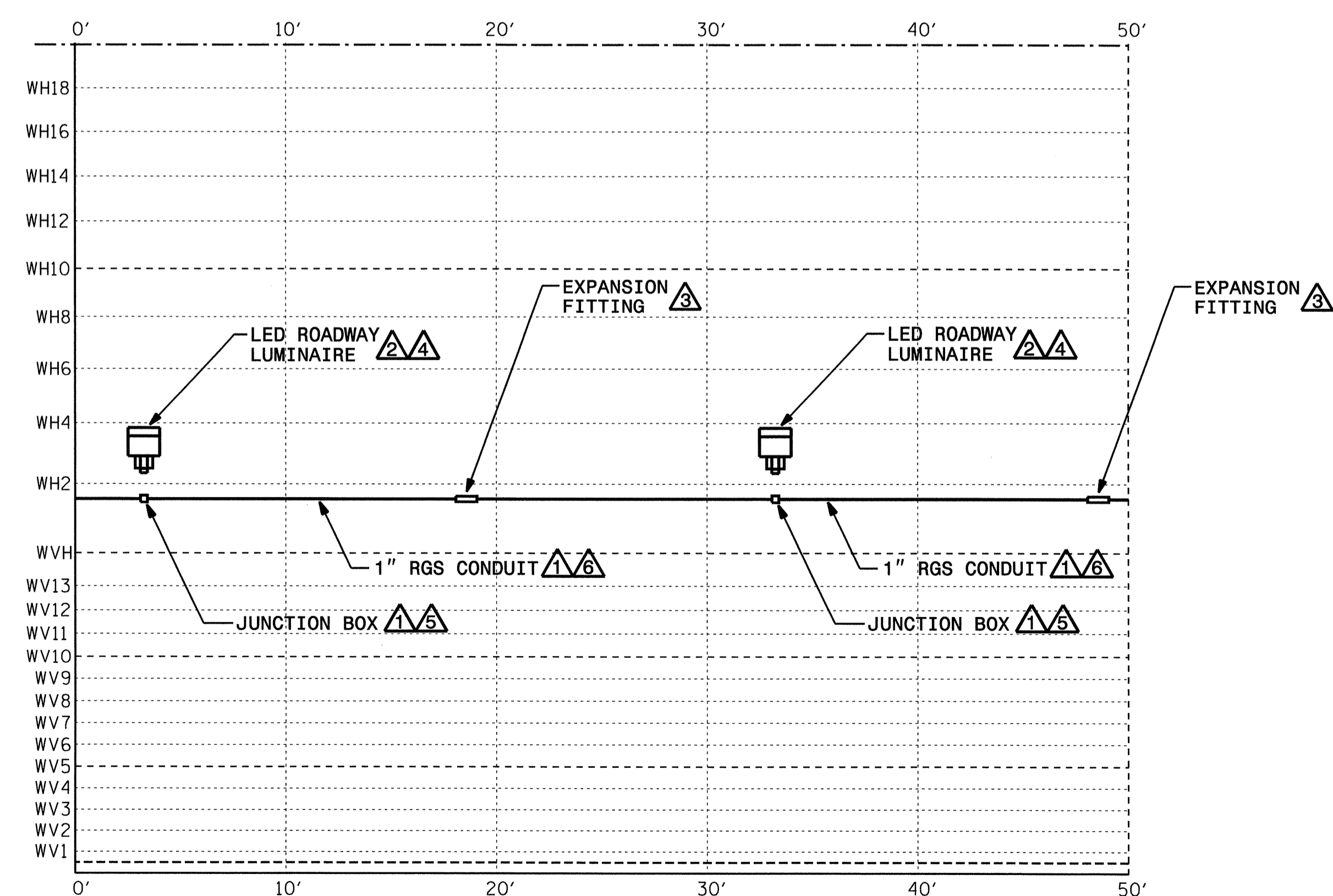

VIEW B-B

NOTES

- 1 PROVIDE 1/4" X 3 1/2" ADHESIVELY ANCHORED THREADED RODS WITH 2 1/2" EMBEDMENT TO SECURE JUNCTION BOXES AND CONDUIT STRAPS TO WALL OF TUNNEL.
- 2 MINIMUM MOUNTING HEIGHT IS 17' ABOVE ROADWAY FROM THE BOTTOM OF THE LED ROADWAY LUMINAIRE OR MOUNTING BRACKET, WHICHEVER IS LOWEST. TYPICAL FOR ALL LUMINAIRE IN TUNNEL. SEE MOUNTING BRACKET DETAILS ON SHEET E9.
- 3 PROVIDE EXPANSION FITTINGS IN EACH SECTION OF CONDUIT THAT IS GREATER THAN 20' LONG BETWEEN TERMINALS AT JUNCTION BOXES.
- 4 PROVIDE 3/8" X 3 1/2" ADHESIVELY ANCHORED THREADED RODS WITH 2 1/2" EMBEDMENT TO SECURE LUMINAIRE MOUNTING BRACKETS TO WALL OF TUNNEL.
- 5 PROVIDE GALVANIZED CAST IRON JUNCTION BOX, 4" SQUARE, 2" DEEP WITH GASKETED COVER. PROVIDE GALVANIZED, RAIN TIGHT, THREADED CONDUIT HUB FITTINGS. PROVIDE A 1" HUB ON TWO SIDES AND A 3/4" HUB ON TOP.
- 6 PROVIDE CONDUIT STRAPS W/BACK FOR SUPPORTING CONDUITS. INSTALL STRAPS @ 5' SPACING, MAXIMUM, AND INSTALL WITHIN 3' OF JUNCTION BOXES AND CONDULETS.
- 7 EQUIPMENT MOUNTING HEIGHTS AND ARRANGEMENT ARE TYPICAL FOR ALL SECTIONS OF THE TUNNEL. SEE SHEET E3 FOR LUMINAIRE LOCATIONS AND SPACING.

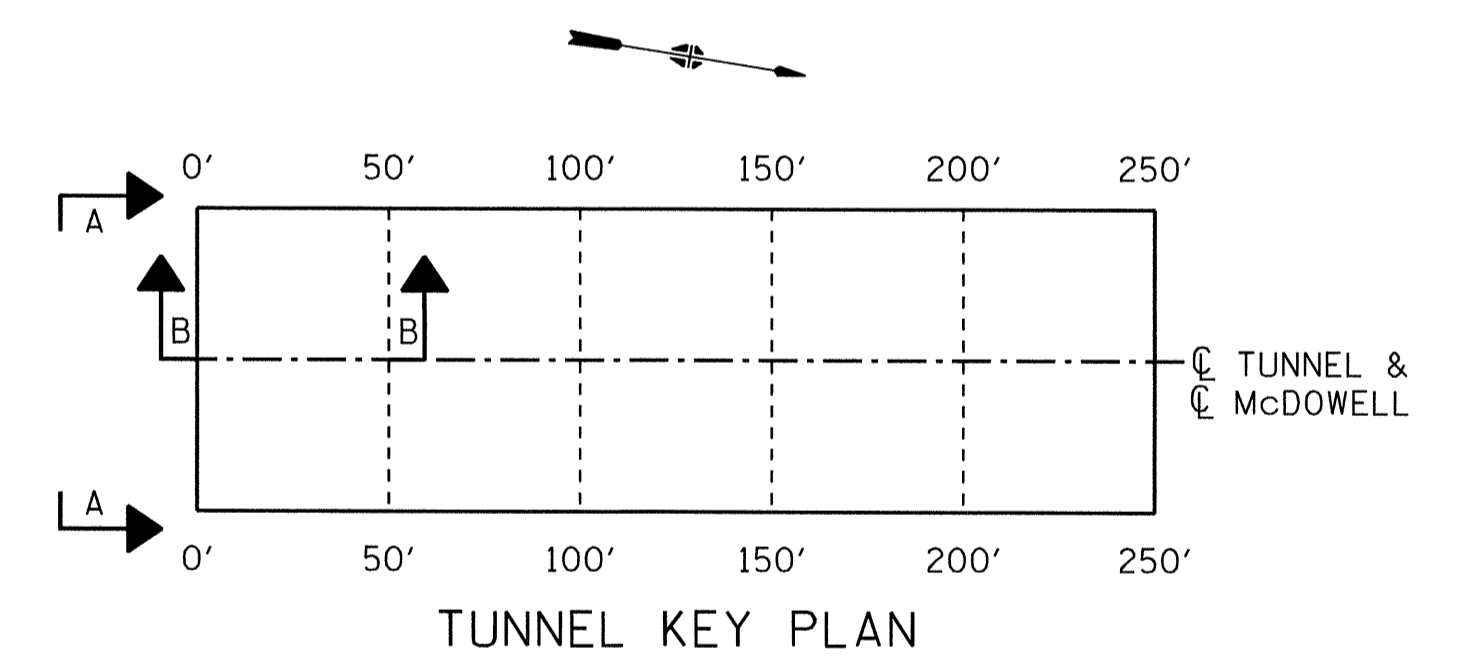

TUNNEL KEY PLAN

PROJECT NO. U-4014
 BUNCOMBE COUNTY
 STATION: _____

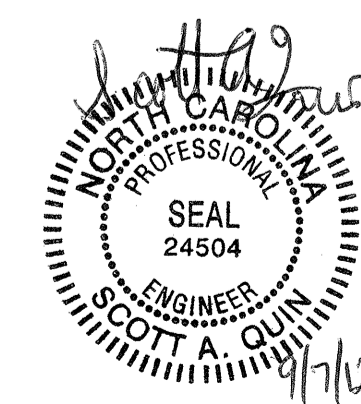

STATE OF NORTH CAROLINA
 DEPARTMENT OF TRANSPORTATION
 RALEIGH

TUNNEL LIGHTING

DRAWN BY: C.L. SHAW DATE: 07/11
 CHECKED BY: S.A. QUIN DATE: 07/11

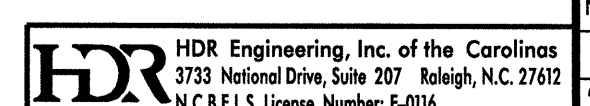

REVISIONS						SHEET NO. U4014-E4
NO.	BY:	DATE:	NO.	BY:	DATE:	
1			3			TOTAL SHEETS 9
2			4			

PLOT DRIVER: NCDOT_pdf_mono_eng_50.plt
 USER: dwainwr1
 DATE: 9/6/2012
 TIME: 6:47:51 PM
 FILE: North Carolina Dept. of Transportation\13.00.CAD\U-4014\Lighting\Local\Lighting\Design\U4014_E5.dgn

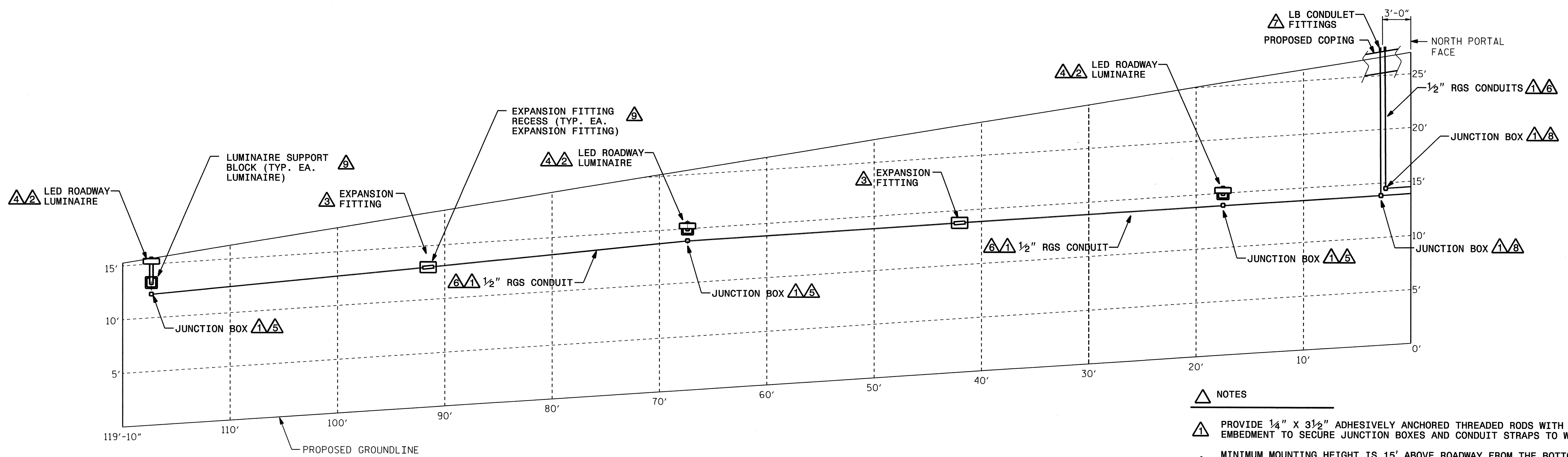

ELEVATION - NORTHEAST WINGWALL LIGHTING

- NOTES**
- 1 PROVIDE 1/4" X 3 1/2" ADHESIVELY ANCHORED THREADED RODS WITH 2 1/2" EMBEDMENT TO SECURE JUNCTION BOXES AND CONDUIT STRAPS TO WINGWALL.
 - 2 MINIMUM MOUNTING HEIGHT IS 15' ABOVE ROADWAY FROM THE BOTTOM OF THE LED ROADWAY LUMINAIRE. THIS IS TYPICAL FOR ALL LUMINAIRES ON WINGWALL. SEE MOUNTING BRACKET DETAILS ON SHEET E9.
 - 3 PROVIDE EXPANSION FITTINGS IN EACH SECTION OF CONDUIT THAT IS GREATER THAN 20' LONG BETWEEN TERMINALS AT JUNCTION BOXES. PROVIDE EXPANSION FITTINGS WITH THE FOLLOWING DIMENSIONS: 1.75" MAX O.D., 6.75" LONG.
 - 4 PROVIDE 3/8" X 3 1/2" ADHESIVELY ANCHORED THREADED RODS WITH 2 1/2" EMBEDMENT TO SECURE LUMINAIRE MOUNTING BRACKETS TO FACE OF VENEER.
 - 5 PROVIDE GALVANIZED CAST IRON JUNCTION BOX, 4" SQUARE, 2" DEEP WITH GASKETED COVER. PROVIDE GALVANIZED, RAIN TIGHT, THREADED CONDUIT HUB FITTINGS. PROVIDE 1/2" HUBS ON THE BACK AND A 3/4" HUB ON TOP. MOUNT JUNCTION BOX TO FACE OF VENEER.
 - 6 PROVIDE CONDUIT STRAPS W/BACK FOR SUPPORTING CONDUITS. INSTALL STRAPS @ 5' SPACING, MAXIMUM, AND INSTALL WITHIN 3' OF JUNCTION BOXES AND CONDULETS.
 - 7 PROVIDE LB FITTINGS TO ROUTE CONDUITS THROUGH WINGWALL COPING AND OVER WINGWALL. SEE SHEET E2.
 - 8 PROVIDE GALVANIZED CAST IRON JUNCTION BOX, 4" SQUARE, 2" DEEP WITH GASKETED COVER. PROVIDE GALVANIZED, RAIN TIGHT, THREADED CONDUIT HUB FITTINGS. PROVIDE 1/2" HUBS ON THE BACK.
 - 9 FOR LUMINAIRE SUPPORT BLOCK AND EXPANSION FITTING RECESS DETAILS, SEE STRUCTURE PLANS.

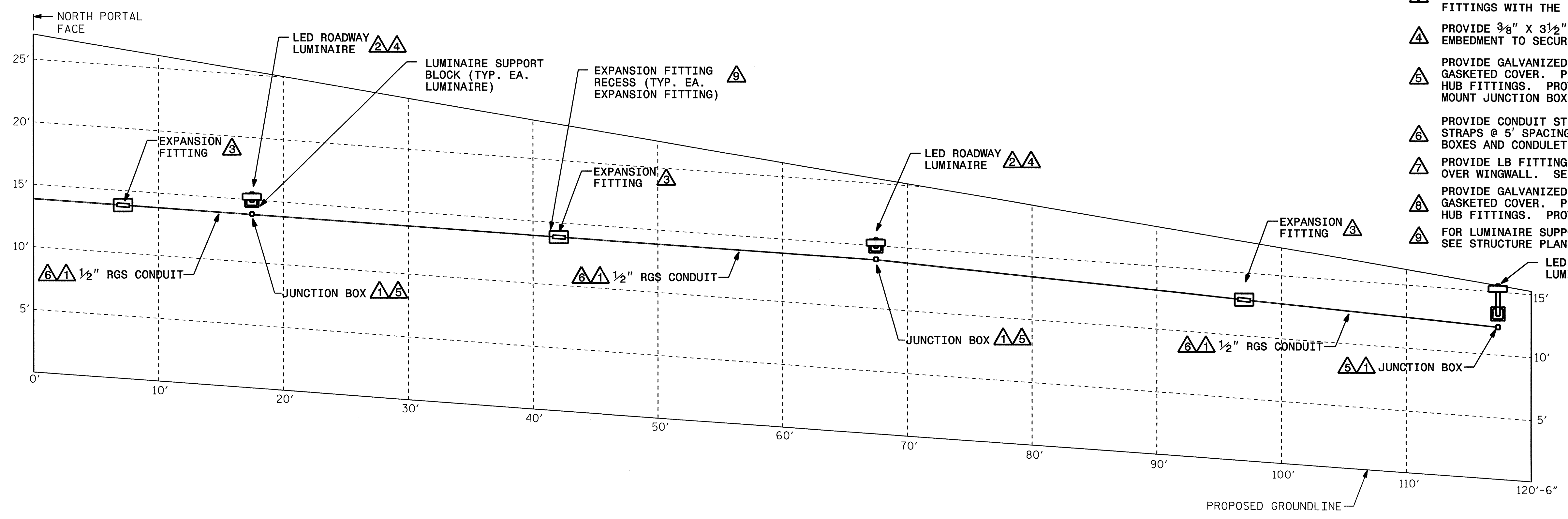

ELEVATION - NORTHWEST WINGWALL LIGHTING

PROJECT NO. U-4014
 BUNCOMBE COUNTY
 STATION: _____

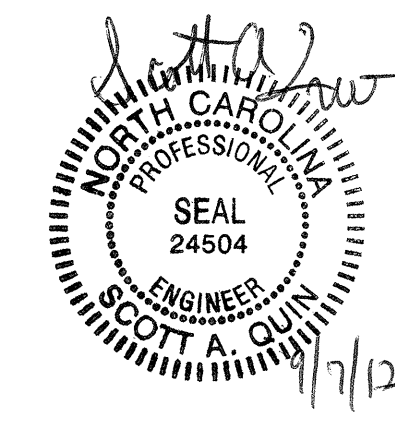

STATE OF NORTH CAROLINA
 DEPARTMENT OF TRANSPORTATION
 RALEIGH

NORTHEAST AND NORTHWEST WINGWALL ELEVATION LIGHTING

REVISIONS					
NO.	BY:	DATE:	NO.	BY:	DATE:
1			3		
2			4		

SHEET NO. U4014-E5
 TOTAL SHEETS 9

DRAWN BY: C.L. SHAW DATE: 07/11
 CHECKED BY: S.A. QUIN DATE: 07/11

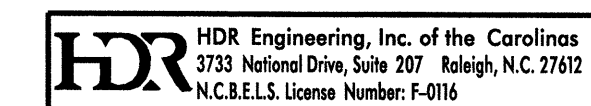

PLOT DRIVER: NCDOT_pdf_mono_eng_50.plt
 USER: dwojnwrf
 DATE: 9/6/2012
 TIME: 6:47:59 PM
 FILE: North Carolina Dept. of Transportation\NCDOT_U_4014_McDowellStreet\13.00.CAD\U-4014\Lighting\Lighting-Design\U4014_E6.dgn

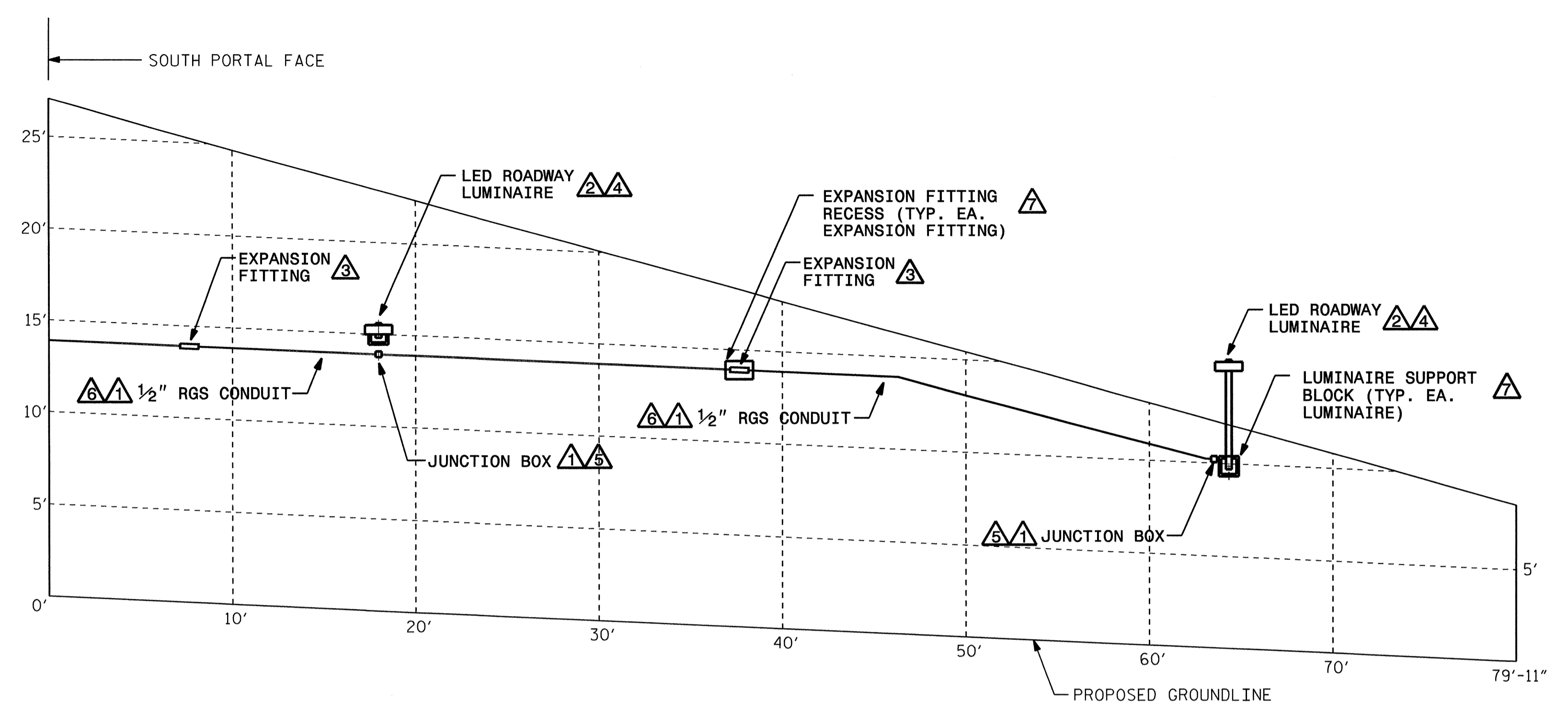

ELEVATION - SOUTHEAST WINGWALL LIGHTING

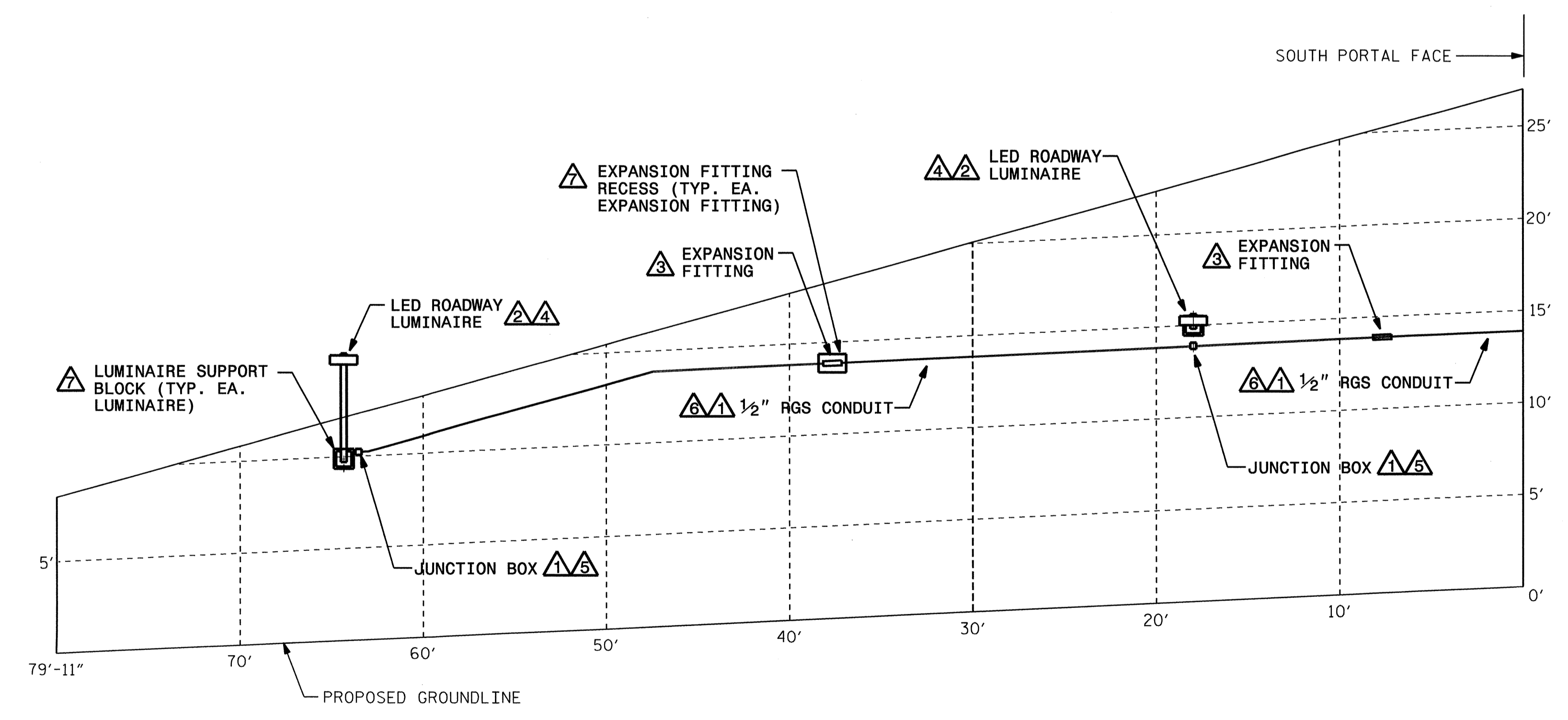

ELEVATION - SOUTHWEST WINGWALL LIGHTING

- △ NOTES
- △ PROVIDE 1/4" X 3 1/2" ADHESIVELY ANCHORED THREADED RODS WITH 2 1/2" EMBEDMENT TO SECURE JUNCTION BOXES AND CONDUIT STRAPS TO WINGWALL.
 - △ MINIMUM MOUNTING HEIGHT IS 15' ABOVE ROADWAY FROM THE BOTTOM OF THE LED ROADWAY LUMINAIRE. TYPICAL FOR ALL LUMINAIRES ON WINGWALLS. SEE MOUNTING BRACKET DETAILS ON SHEET E9.
 - △ PROVIDE EXPANSION FITTINGS IN EACH SECTION OF CONDUIT THAT IS GREATER THAN 20' LONG BETWEEN TERMINALS AT JUNCTION BOXES. PROVIDE EXPANSION FITTINGS WITH THE FOLLOWING DIMENSIONS: 1.75" MAX O.D., 6.75" LONG.
 - △ PROVIDE 3/8" X 3 1/2" ADHESIVELY ANCHORED THREADED RODS WITH 2 1/2" EMBEDMENT TO SECURE LUMINAIRE MOUNTING BRACKETS TO FACE OF VENEER.
 - △ PROVIDE GALVANIZED CAST IRON JUNCTION BOX, 4" SQUARE, 2" DEEP WITH GASKETED COVER. PROVIDE GALVANIZED, RAIN-TIGHT, THREADED CONDUIT HUB FITTINGS. PROVIDE 1/2" HUBS ON THE BACK AND A 3/4" HUB ON TOP. MOUNT JUNCTION BOX TO FACE OF VENEER.
 - △ PROVIDE CONDUIT STRAPS W/BACK FOR SUPPORTING CONDUITS. INSTALL STRAPS @ 5' SPACING, MAXIMUM, AND INSTALL WITHIN 3' OF JUNCTION BOXES AND CONDULETS.
 - △ FOR LUMINAIRE SUPPORT BLOCK AND EXPANSION FITTING RECESS DETAILS, SEE STRUCTURE PLANS.

PROJECT NO. U-4014
 BUNCOMBE COUNTY
 STATION: _____



STATE OF NORTH CAROLINA
 DEPARTMENT OF TRANSPORTATION
 RALEIGH

SOUTHEAST AND SOUTHWEST WINGWALL ELEVATION LIGHTING

REVISIONS					
NO.	BY:	DATE:	NO.	BY:	DATE:
1			3		
2			4		

SHEET NO. U4014-E6
TOTAL SHEETS 9

DRAWN BY: C.L. SHAW DATE: 07/11
 CHECKED BY: S.A. QUIN DATE: 07/11

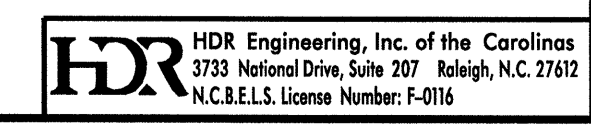

STATE OF NORTH CAROLINA
 DEPT. OF TRANSPORTATION
 DIVISION OF HIGHWAYS
 RALEIGH, N.C.

ENGLISH DETAIL DRAWING FOR
LIGHT CONTROL SYSTEM
 SCHEMATIC

SHEET 1 OF 3
1408D01

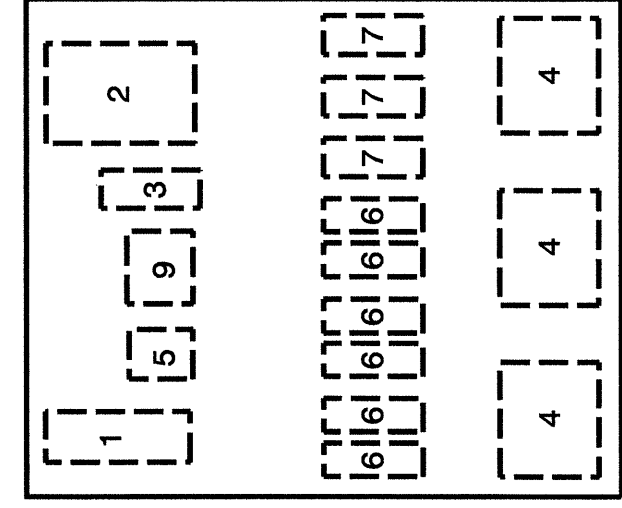
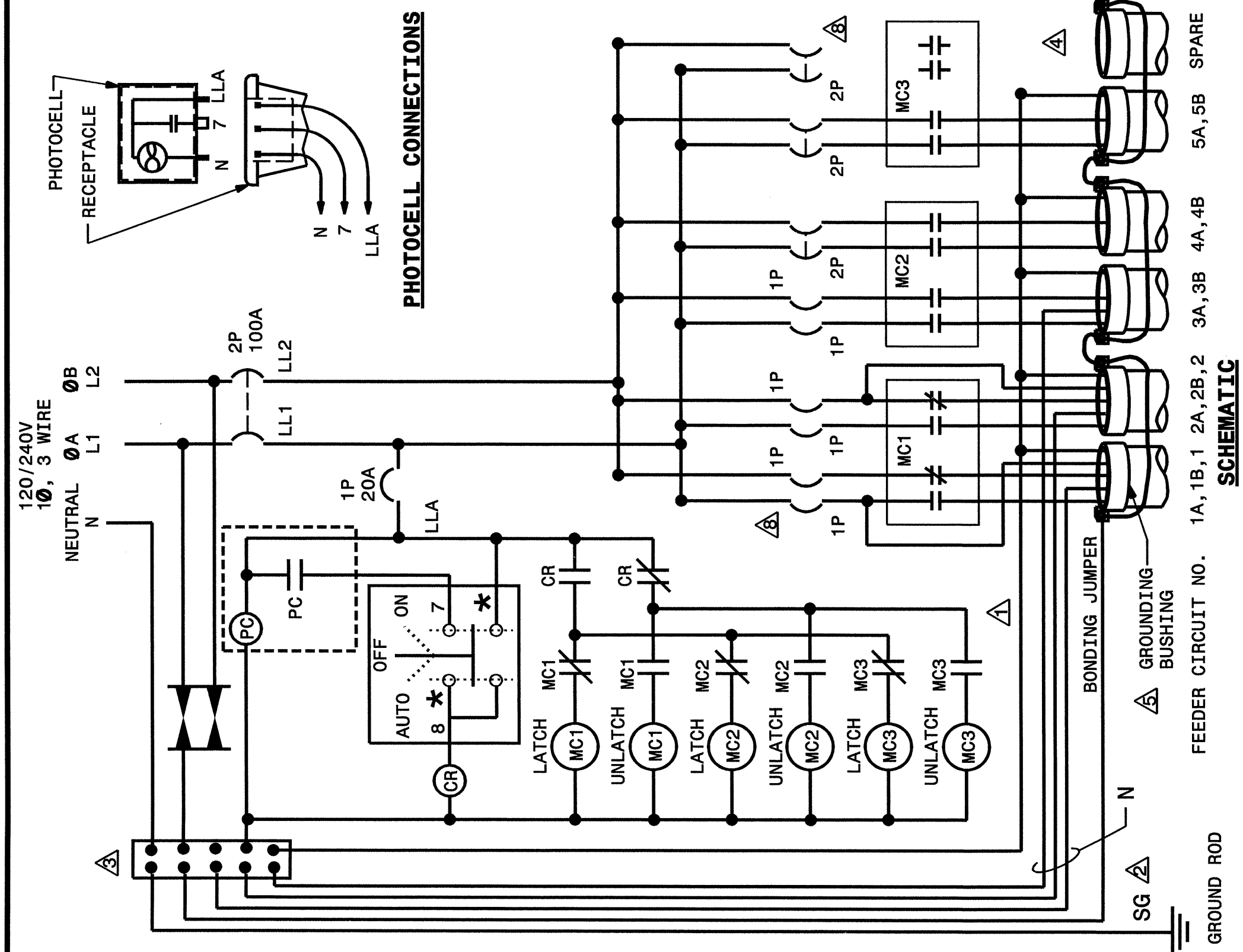

INTERIOR PANEL COMPONENT LAYOUT

#	QTY	DESCRIPTION	SPECIFICATIONS
1	1	NEUTRAL BAR	
2	1	SERVICE CIRCUIT BREAKER	2P, 240V, 100A
3	1	CONTROL CIRCUIT BREAKER	1P, 120V, 20A
4	3	MECHANICALLY HELD CONTACTORS	4P, 240V, 60A W/120V COIL
5	1	CONTROL RELAY W/NC & NO CONTACT	120V, 10A, W/120V COIL
6	6	FEEDER CIRCUIT BREAKERS	1P, 120V, 50A MAX
7	3	FEEDER CIRCUIT BREAKERS	2P, 240V, 50A MAX
8	1	LIGHTNING ARRESTER	
9	1	SELECTOR SWITCH (ON-OFF-AUTO)	120V, 10A

- NOTES**
- EQUIPMENT GROUND (G) SHALL BE SIZED ACCORDING TO NEC 250-79.
 - SYSTEM GROUND (SG) SHALL BE CONTINUOUS FROM THE NEUTRAL BAR TO THE GROUNDING ELECTRODE (GROUND ROD).
 - THE NEUTRAL BAR SHALL BE BONDED TO THE PANEL.
 - FEEDER CIRCUITS NOT SHOWN ON THE PLANS SHALL NOT BE INSTALLED, BUT CONDUIT SHALL BE INSTALLED AND CAPPED.
 - INSTALL A GROUNDING BUSHING ON EACH CONDUIT. CONNECT BONDING JUMPER AS REQUIRED BY NEC.
 - SEE SHEET 3 OF 3 FOR ENCLOSURE.
 - THE CONTROL SYSTEM SHALL BE LABELED IN ACCORDANCE WITH SECTION 90-7 OF THE NEC.
 - 20A BREAKERS, TYPICAL FOR 1P AND 2P.
 - INSTALL LIGHTNING ARRESTOR OUTSIDE OF ENCLOSURE.

ENGLISH DETAIL DRAWING FOR
LIGHT CONTROL SYSTEM
 SCHEMATIC

STATE OF NORTH CAROLINA
 DEPT. OF TRANSPORTATION
 DIVISION OF HIGHWAYS
 RALEIGH, N.C.

SHEET 1 OF 3
1408D01

STATE OF NORTH CAROLINA
 DEPT. OF TRANSPORTATION
 DIVISION OF HIGHWAYS
 RALEIGH, N.C.

ENGLISH DETAIL DRAWING FOR
LIGHT CONTROL SYSTEM
 ASSEMBLY

SHEET 2 OF 3
1408D01

- NOTES**
- CURRENT TRANSFORMER (CT) CABINET AND METER MAY BE MOUNTED ON SERVICE POLE OR BACK OF CONTROL ENCLOSURE.
 - SEE SECTION 1407 OF THE STANDARD SPECIFICATIONS FOR SERVICE POLE AND SERVICE LATERAL.
 - SEE PLANS FOR SIZE OF CONDUITS AND/OR ELECTRICAL DUCT.

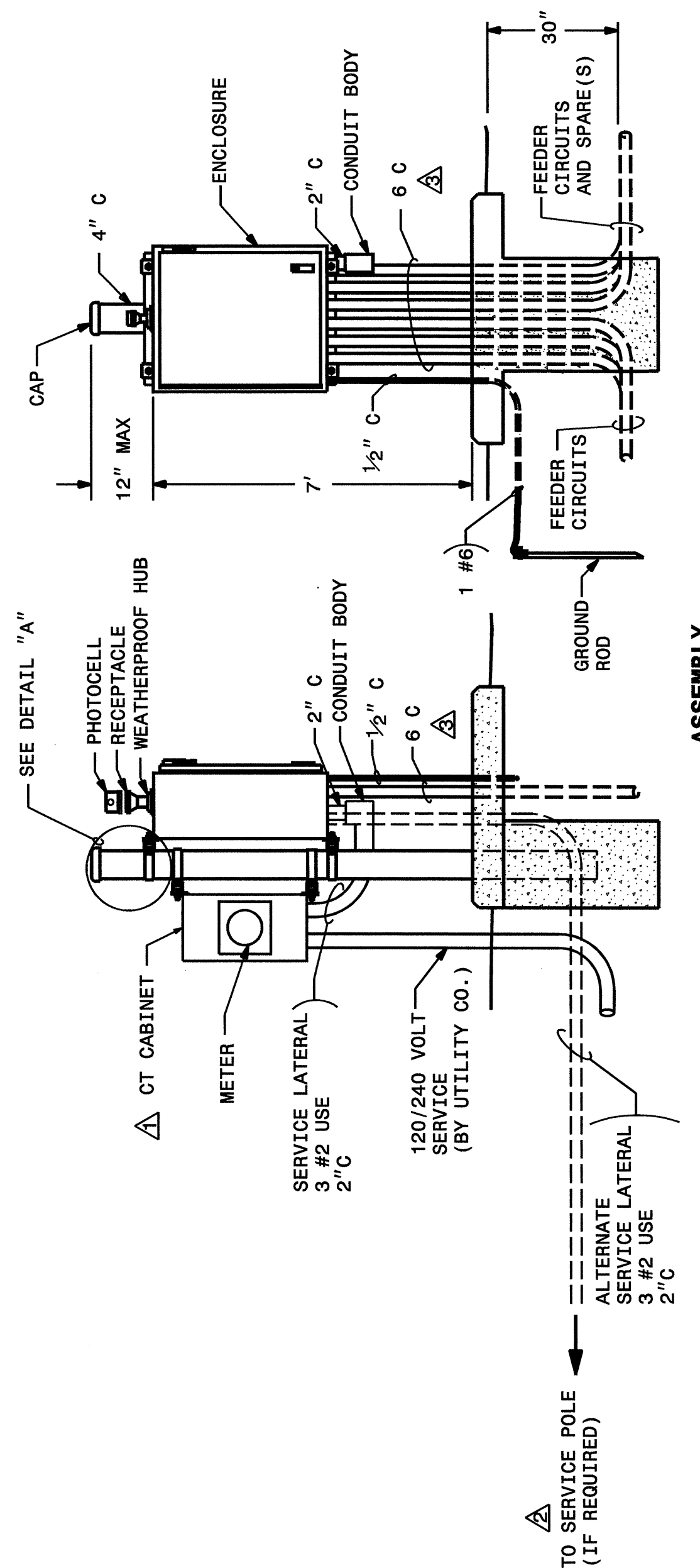
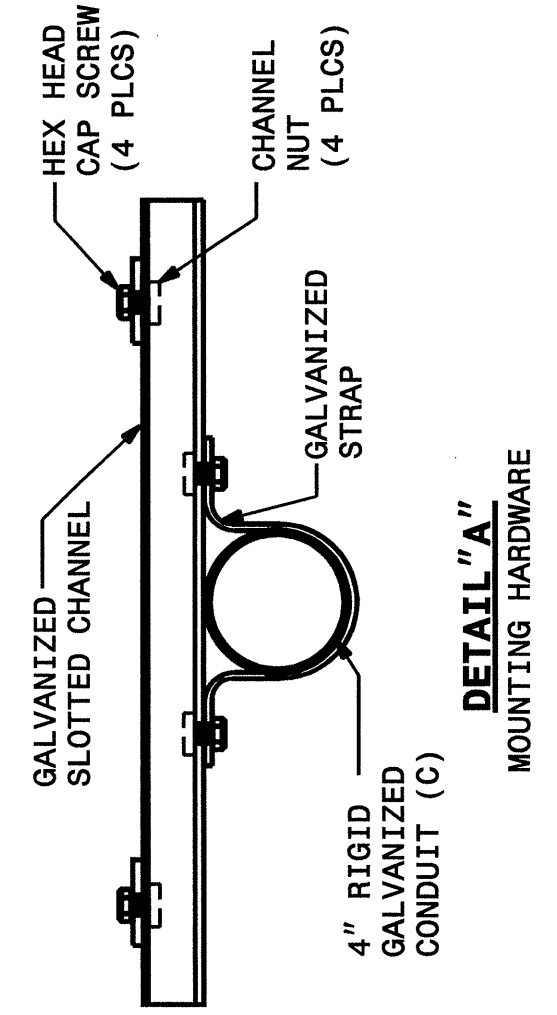

STATE OF NORTH CAROLINA
 DEPT. OF TRANSPORTATION
 DIVISION OF HIGHWAYS
 RALEIGH, N.C.

ENGLISH DETAIL DRAWING FOR
LIGHT CONTROL SYSTEM
 ASSEMBLY

SHEET 2 OF 3
1408D01

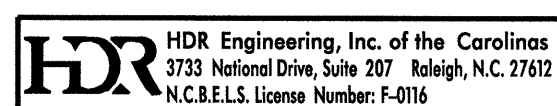

PROJECT NO. U-4014
 BUNCOMBE COUNTY
 STATION:

STATE OF NORTH CAROLINA DEPARTMENT OF TRANSPORTATION RALEIGH					
ELECTRICAL DETAILS					
REVISIONS					
NO.	BY:	DATE:	NO.	BY:	DATE:
1			3		
2			4		
					SHEET NO. U4014-E7 TOTAL SHEETS 9

PLOT DRIVER: NCDOT_pdf_mono_eng-50.plt
 USER: dwinwr1 DATE: 9/6/2012 TIME: 6:48:13 PM
 FILE: North Carolina Dept. of Transportation\NCDOT_U-4014_McDowellStreet\13.00.CAD\U-4014_LightingElectrical\Lighting_Design\U4014_EB.dgn

STATE OF NORTH CAROLINA
 DEPT. OF TRANSPORTATION
 DIVISION OF HIGHWAYS
 RALEIGH, N.C.

ENGLISH STANDARD DRAWING FOR
LIGHT CONTROL SYSTEM
 FOUNDATION AND ENCLOSURE

SHEET 3 OF 3
1408D01

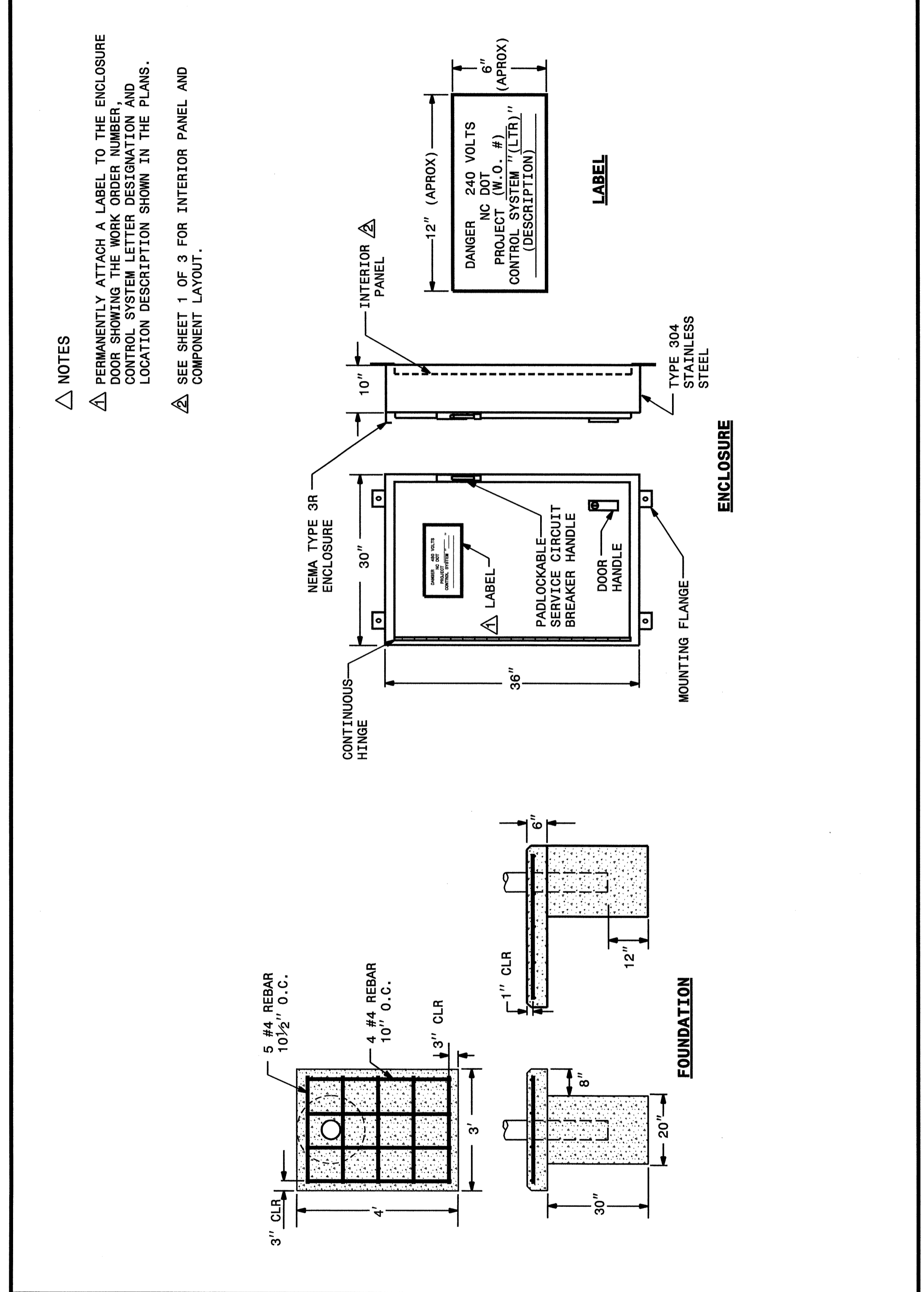

STATE OF NORTH CAROLINA
 DEPT. OF TRANSPORTATION
 DIVISION OF HIGHWAYS
 RALEIGH, N.C.

ENGLISH STANDARD DRAWING FOR
LIGHT CONTROL SYSTEM
 FOUNDATION AND ENCLOSURE

SHEET 3 OF 3
1408D01

PROJECT NO. U-4014
 BUNCOMBE COUNTY
 STATION:



STATE OF NORTH CAROLINA
 DEPARTMENT OF TRANSPORTATION
 RALEIGH

ELECTRICAL DETAILS

REVISIONS						SHEET NO. U4014-EB	
NO.	BY:	DATE:	NO.	BY:	DATE:	TOTAL SHEETS 9	
1			3				
2			4				

HDR HDR Engineering, Inc. of the Carolinas
 3723 National Drive, Suite 207 Raleigh, N.C. 27612
 N.C.B.E.L.S. License Number: F-4016

DRAWN BY: C.L. SHAW DATE: 07/11
 CHECKED BY: S.A. QUIN DATE: 07/11

GENERAL NOTES

1. DIMENSIONS AND MATERIALS ARE TYPICAL FOR ALL BRACKETS.
2. ALL DIMENSIONS FOR MOUNTING BRACKET ARE NOMINAL. PROVIDE MINOR ADJUSTMENT TO DIMENSIONS AS REQUIRED.

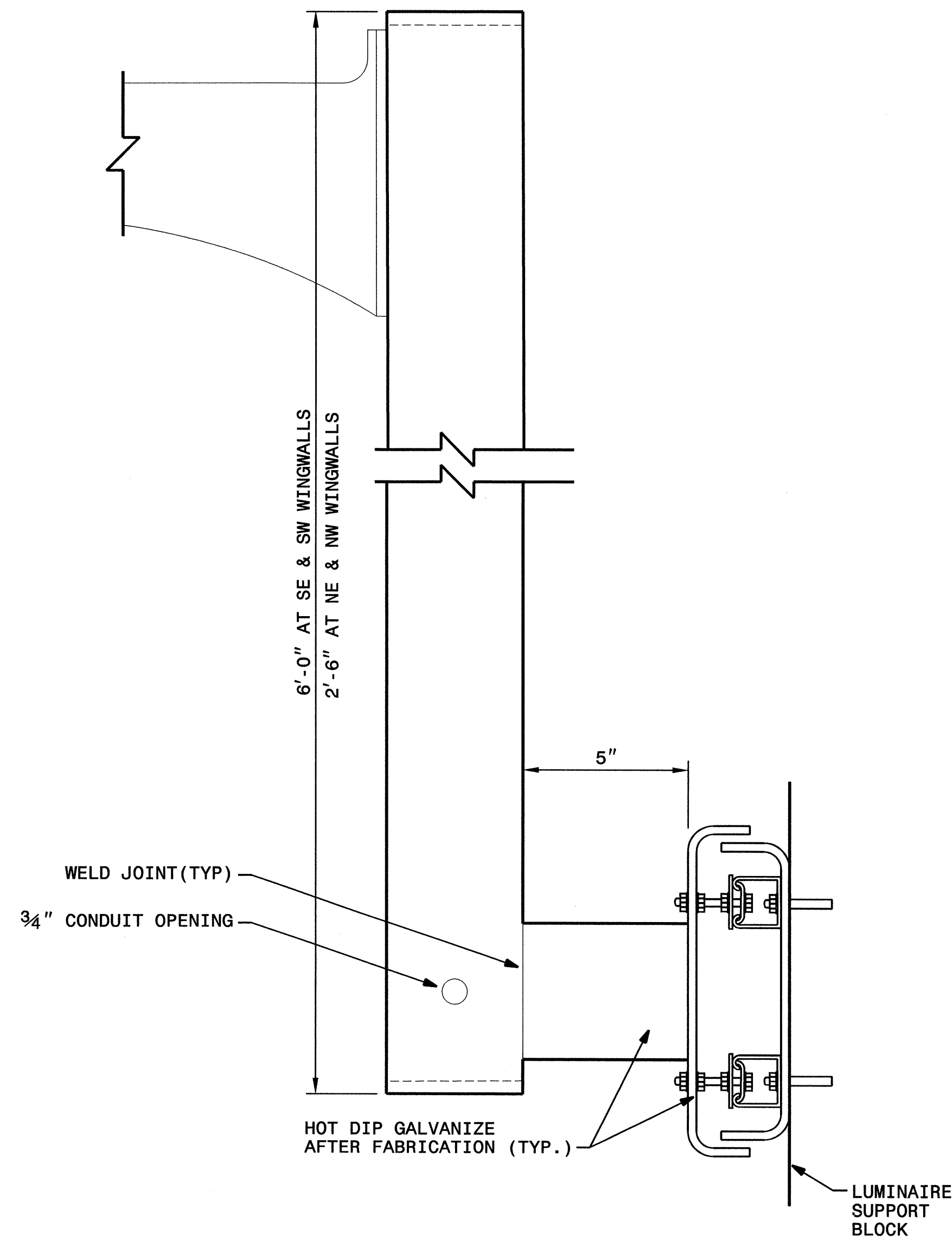

MOUNTING BRACKET (TYP. OF 4)
NOT TO SCALE

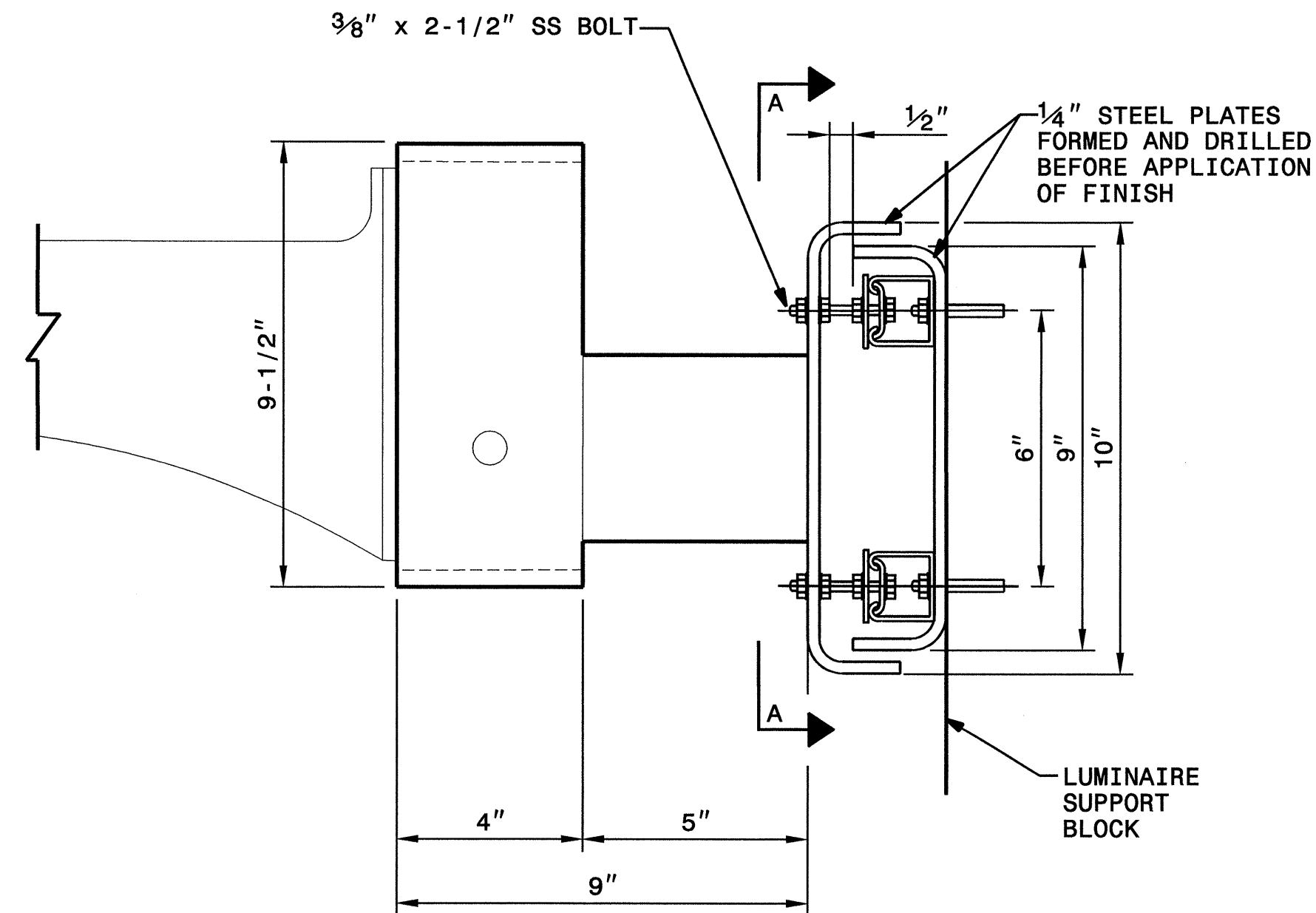

WINGWALL MOUNTING BRACKET (TYP. OF 6)
NOT TO SCALE

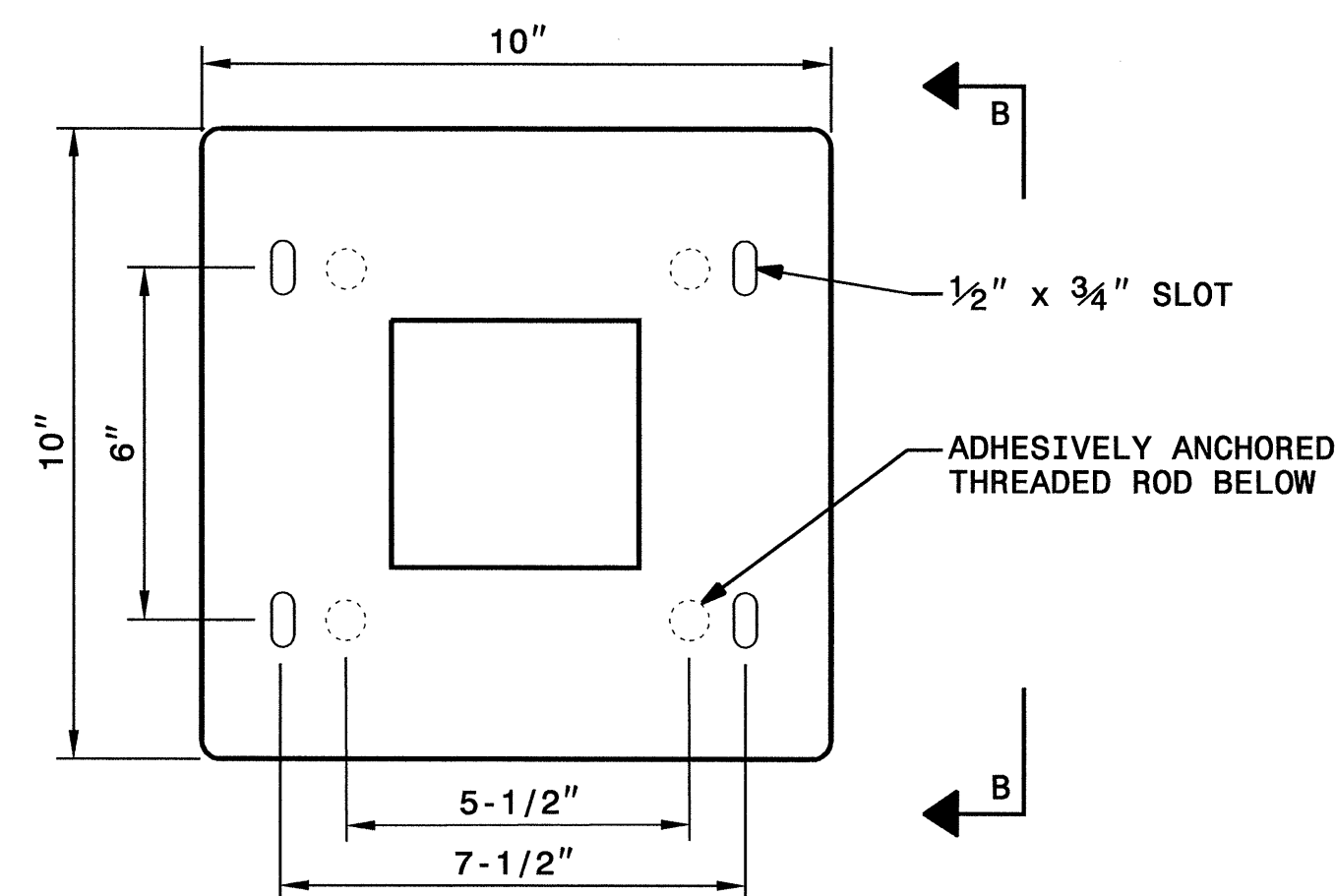

SECTION A-A
NOT TO SCALE

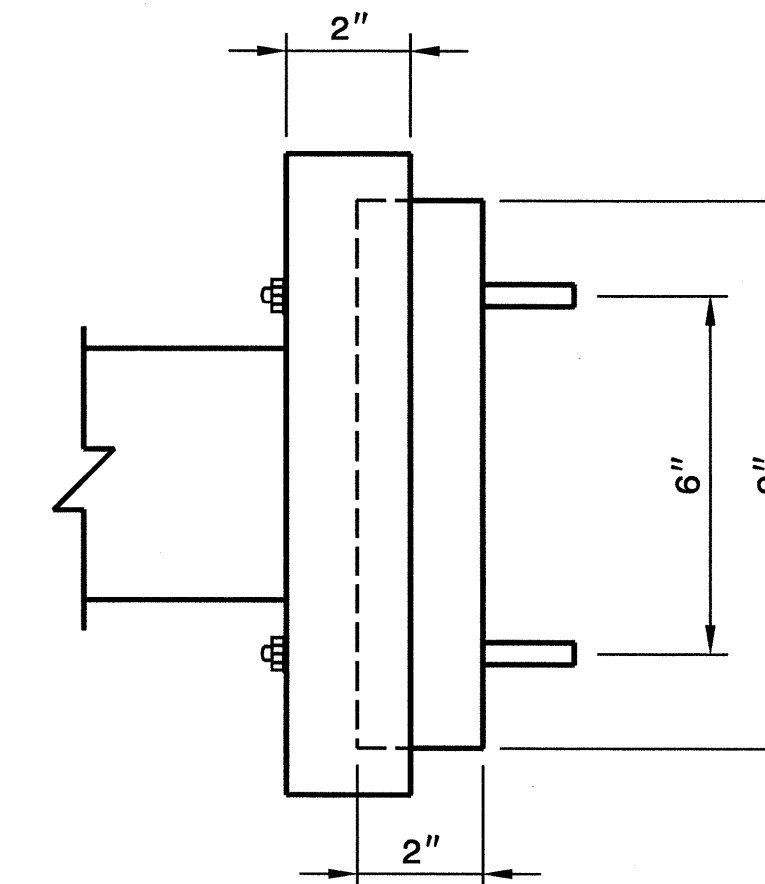

SECTION B-B
NOT TO SCALE

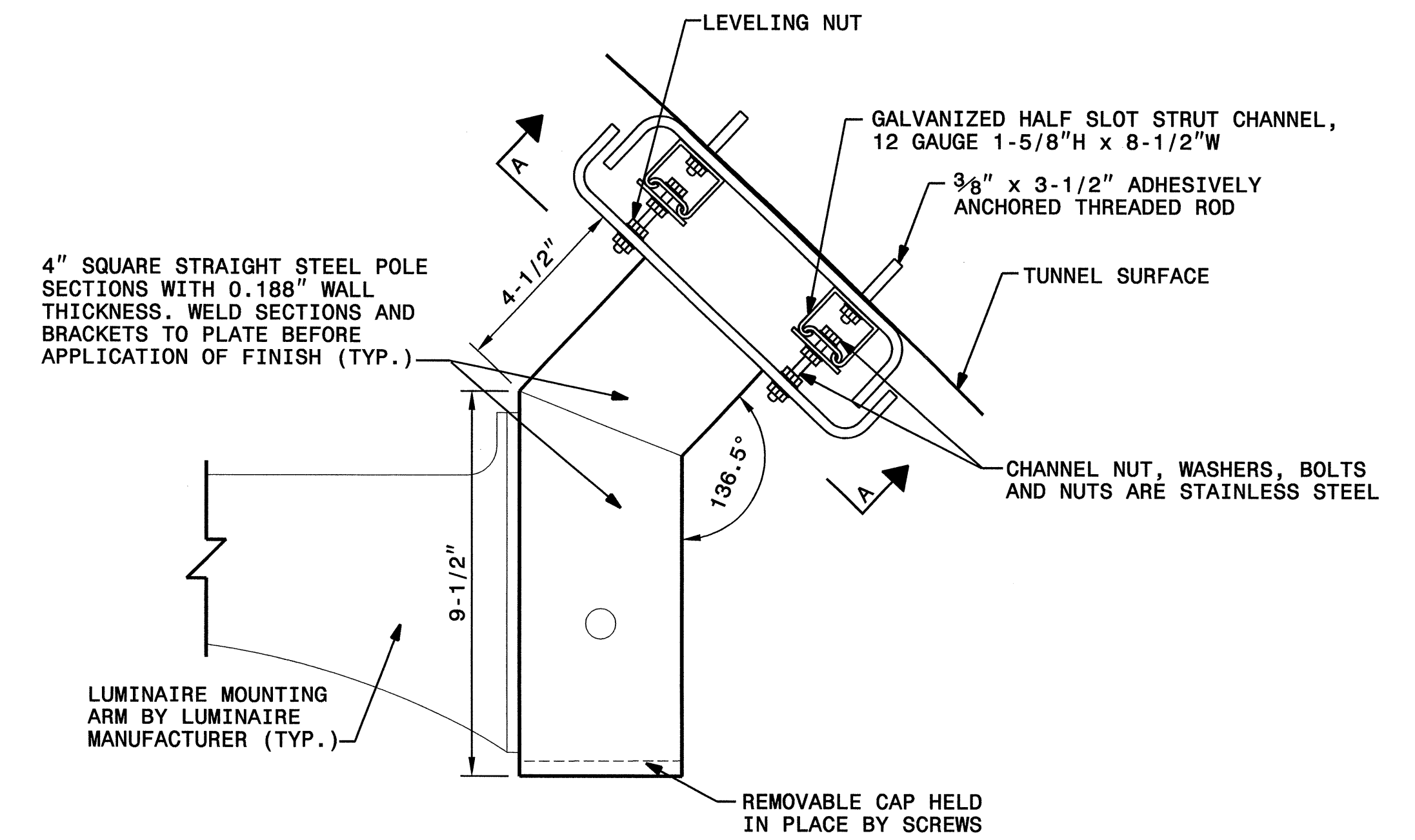

4" SQUARE STRAIGHT STEEL POLE SECTIONS WITH 0.188" WALL THICKNESS, WELD SECTIONS AND BRACKETS TO PLATE BEFORE APPLICATION OF FINISH (TYP.)

LUMINAIRE MOUNTING ARM BY LUMINAIRE MANUFACTURER (TYP.)

TUNNEL MOUNTING BRACKET (TYP. OF 18)
NOT TO SCALE

PLOT DRIVER: NCDOT_pdf_mono_eng_50.plt
 USER: dwdjwrf
 DATE: 9/6/2012
 TIME: 6:48:59 PM
 FILE: North Carolina Dept. of Transportation\NCDOT_U_4014_McDowell_Street\13.00_CAD_U-4014\Lighting\Electrical\Lighting_Design\U4014_E9.dgn

DRAWN BY : _____ DATE : _____
 CHECKED BY : S.A. QUIN DATE : 07/11

PROJECT NO. U-4014
 BUNCOMBE COUNTY
 STATION: _____



STATE OF NORTH CAROLINA DEPARTMENT OF TRANSPORTATION RALEIGH					
ELECTRICAL DETAILS					
REVISIONS					
NO.	BY:	DATE:	NO.	BY:	DATE:
1			3		
2			4		
					SHEET NO. U4014-E9 TOTAL SHEETS 9

HDR Engineering, Inc. of the Carolinas
 3783 National Drive, Suite 207 Raleigh, N.C. 27612
 N.C. E.L.S. License Number: F-0116

STANDARD NOTES

DESIGN DATA:

SPECIFICATIONS	-----	A.A.S.H.T.O. (CURRENT)
LIVE LOAD	-----	SEE PLANS
IMPACT ALLOWANCE	-----	SEE A.A.S.H.T.O.
STRESS IN EXTREME FIBER OF		
STRUCTURAL STEEL - AASHTO M270 GRADE 36	-	20,000 LBS. PER SQ. IN.
- AASHTO M270 GRADE 50W	-	27,000 LBS. PER SQ. IN.
- AASHTO M270 GRADE 50	-	27,000 LBS. PER SQ. IN.
REINFORCING STEEL IN TENSION		
GRADE 60	--	24,000 LBS. PER SQ. IN.
CONCRETE IN COMPRESSION	-----	1,200 LBS. PER SQ. IN.
CONCRETE IN SHEAR	-----	SEE A.A.S.H.T.O.
STRUCTURAL TIMBER - TREATED OR		
UNTREATED - EXTREME FIBER STRESS	-----	1,800 LBS. PER SQ. IN.
COMPRESSION PERPENDICULAR TO GRAIN OF TIMBER	-----	375 LBS. PER SQ. IN.
EQUIVALENT FLUID PRESSURE OF EARTH	-----	30 LBS. PER CU. FT.
		(MINIMUM)

MATERIAL AND WORKMANSHIP:

EXCEPT AS MAY OTHERWISE BE SPECIFIED ON PLANS OR IN THE SPECIAL PROVISIONS, ALL MATERIAL AND WORKMANSHIP SHALL BE IN ACCORDANCE WITH THE 2012 "STANDARD SPECIFICATIONS FOR ROADS AND STRUCTURES" OF THE N. C. DEPARTMENT OF TRANSPORTATION.

STEEL SHEET PILING FOR PERMANENT OR TEMPORARY APPLICATIONS SHALL BE HOT ROLLED.

CONCRETE:

UNLESS OTHERWISE REQUIRED ON PLANS, CLASS A CONCRETE SHALL BE USED FOR ALL PORTIONS OF ALL STRUCTURES WITH THE EXCEPTION THAT: CLASS AA CONCRETE SHALL BE USED IN BRIDGE SUPERSTRUCTURES, ABUTMENT BACKWALLS, AND APPROACH SLABS; AND CLASS B CONCRETE SHALL BE USED FOR SLOPE PROTECTION AND RIP RAP.

CONCRETE CHAMFERS:

UNLESS OTHERWISE NOTED ON THE PLANS, ALL EXPOSED CORNERS ON STRUCTURES SHALL BE CHAMFERED 3/4" WITH THE FOLLOWING EXCEPTIONS: TOP CORNERS OF CURBS MAY BE ROUNDED TO 1-1/2" RADIUS WHICH IS BUILT INTO CURB FORMS; CORNERS OF TRANSVERSE FLOOR EXPANSION JOINTS SHALL BE ROUNDED WITH A 1/4" FINISHING TOOL UNLESS OTHERWISE REQUIRED ON PLANS; AND CORNERS OF EXPANSION JOINTS IN THE ROADWAY FACES AND TOPS OF CURBS AND SIDEWALKS SHALL BE ROUNDED TO A 1/4" RADIUS WITH A FINISHING STONE OR TOOL UNLESS OTHERWISE REQUIRED ON PLANS.

DOWELS:

DOWELS WHEN INDICATED ON PLANS AS FOR CULVERT EXTENSIONS, SHALL BE EMBEDDED AT LEAST 12" INTO THE OLD CONCRETE AND GROUTED INTO PLACE WITH 1:2 CEMENT MORTAR.

ALLOWANCE FOR DEAD LOAD DEFLECTION, SETTLEMENT, ETC. IN CASTING SUPERSTRUCTURES:

BRIDGES SHALL BE BUILT ON THE GRADE OR VERTICAL CURVE SHOWN ON PLANS. SLABS, CURBS AND PARAPETS SHALL CONFORM TO THE GRADE OR CURVE.
ALL DIMENSIONS WHICH ARE GIVEN IN SECTION AND ARE AFFECTED BY DEAD LOAD DEFLECTIONS ARE DIMENSIONS AT CENTER LINE OF BEARING UNLESS OTHERWISE NOTED ON PLANS. IN SETTING FORMS FOR STEEL BEAM BRIDGES AND PRESTRESSED CONCRETE GIRDER BRIDGES, ADJUSTMENTS SHALL BE MADE DUE TO THE DEAD LOAD DEFLECTIONS FOR THE ELEVATIONS SHOWN. WHERE BLOCKS ARE SHOWN OVER BEAMS FOR BUILDING UP TO THE SLAB, THE VERTICAL DIMENSIONS OF THE BLOCKS SHALL BE ADJUSTED BETWEEN BEARINGS TO COMPENSATE FOR DEAD LOAD DEFLECTIONS, VERTICAL CURVE ORDINATE, AND ACTUAL BEAM CAMBER. WHERE BOTTOM OF SLAB IS IN LINE WITH BOTTOM OF TOP FLANGES, DEPTH OF SLAB BETWEEN BEARINGS SHALL BE ADJUSTED TO COMPENSATE FOR DEAD LOAD DEFLECTION, VERTICAL CURVE ORDINATE, AND ACTUAL BEAM CAMBER.
IN SETTING FALSEWORK AND FORMS FOR REINFORCED CONCRETE SPANS, AN ALLOWANCE SHALL BE MADE FOR DEAD LOAD DEFLECTIONS, SETTLEMENT OF FALSEWORK, AND PERMANENT CAMBER WHICH SHALL BE PROVIDED FOR IN ADDITION TO THE ELEVATIONS SHOWN. AFTER REMOVAL OF THE FALSEWORK, THE FINISHED STRUCTURES SHALL CONFORM TO THE PROFILE AND ELEVATIONS SHOWN ON THE PLANS AND CONSTRUCTION ELEVATIONS FURNISHED BY THE ENGINEER.
DETAILED DRAWINGS FOR FALSEWORK OR FORMS FOR BRIDGE SUPERSTRUCTURE AND ANY STRUCTURE OR PARTS OF A STRUCTURE AS NOTED ON THE PLANS SHALL BE SUBMITTED TO THE ENGINEER FOR APPROVAL BEFORE CONSTRUCTION OF THE FALSEWORK OR FORMS IS STARTED.

REINFORCING STEEL:

ALL REINFORCING STEEL SHALL BE DEFORMED. DIMENSIONS RELATIVE TO PLACEMENT OF REINFORCING ARE TO CENTERS OF BARS UNLESS OTHERWISE INDICATED IN THE PLANS. DIMENSIONS ON BAR DETAILS ARE TO CENTERS OF BARS OR ARE OUT TO OUT AS INDICATED ON PLANS.
WIRE BAR SUPPORTS SHALL BE PROVIDED FOR REINFORCING STEEL WHERE INDICATED ON THE PLANS. WHEN BAR SUPPORT PIECES ARE PLACED IN CONTINUOUS LINES, THEY SHALL BE SO PLACED THAT THE ENDS OF THE SUPPORTING WIRES SHALL BE LAPPED TO LOCK LEGS ON ADJOINING PIECES.

STRUCTURAL STEEL:

AT THE CONTRACTOR'S OPTION, HE MAY SUBSTITUTE 7/8" Ø SHEAR STUDS FOR THE 3/4" Ø STUDS SPECIFIED ON THE PLANS. THIS SUBSTITUTION SHALL BE MADE AT THE RATE OF 3 - 7/8" Ø STUDS FOR 4 - 3/4" Ø STUDS, AND STUD SPACING CHANGES SHALL BE MADE AS NECESSARY TO PROVIDE THE SAME EQUIVALENT NUMBER OF 7/8" Ø STUDS ALONG THE BEAM AS SHOWN FOR 3/4" Ø STUDS BASED ON THE RATIO OF 3 - 7/8" Ø STUDS FOR 4 - 3/4" Ø STUDS. STUDS OF THE LENGTH SPECIFIED ON THE PLANS MUST BE PROVIDED. THE MAXIMUM SPACING SHALL BE 2'-0".
EXCEPT AT THE INTERIOR SUPPORTS OF CONTINUOUS BEAMS WHERE THE COVER PLATE IS IN CONTACT WITH BEARING PLATE, THE CONTRACTOR MAY, AT HIS OPTION, SUBSTITUTE FOR THE COVER PLATES DESIGNATED ON THE PLANS COVER PLATES OF THE EQUIVALENT AREA PROVIDED THESE PLATES ARE AT LEAST 5/16" IN THICKNESS AND DO NOT EXCEED A WIDTH EQUAL TO THE FLANGE WIDTH LESS 2" OR A THICKNESS EQUAL TO 2 TIMES THE FLANGE THICKNESS. THE SIZE OF FILLET WELDS SHALL CONFORM TO THE REQUIREMENTS OF THE CURRENT ANSI/AASHTO/AWS "BRIDGE WELDING CODE". ELECTROSLAG WELDING WILL NOT BE PERMITTED.
WITH THE SOLE EXCEPTION OF EDGES AT SURFACES WHICH BEAR ON OTHER SURFACES, ALL SHARP EDGES AND ENDS OF SHAPES AND PLATES SHALL BE SLIGHTLY ROUNDED BY SUITABLE MEANS TO A RADIUS OF APPROXIMATELY 1/16 INCH OR EQUIVALENT FLAT SURFACE AT A SUITABLE ANGLE PRIOR TO PAINTING, GALVANIZING, OR METALLIZING.

HANDRAILS AND POSTS:

METAL STANDARDS AND FACES OF THE CONCRETE END POSTS FOR THE METAL RAIL SHALL BE SET NORMAL TO THE GRADE OF THE CURB, UNLESS OTHERWISE SHOWN ON PLANS. THE METAL RAIL AND TOPS OF CONCRETE POSTS USED WITH THE ALUMINUM RAIL SHALL BE BUILT PARALLEL TO THE GRADE OF THE CURB.
METAL HANDRAILS SHALL BE IN ACCORDANCE WITH THE PLANS. RAILS SHALL BE AS MANUFACTURED FOR BRIDGE RAILING. CASTINGS SHALL BE OF A UNIFORM APPEARANCE. FINIS AND OTHER DEFORMATIONS RESULTING FROM CASTING OR OTHERWISE SHALL BE REMOVED IN A MANNER SO THAT A UNIFORM COLORING OF THE COMPLETED CASTING SHALL BE OBTAINED. CASTINGS WITH DISCOLORATIONS OR OF NON-UNIFORM COLORING WILL NOT BE ACCEPTED. CERTIFIED MILL REPORTS ARE REQUIRED FOR METAL RAILS AND POSTS.

SPECIAL NOTES:

GENERALLY, IN CASE OF DISCREPANCY, THIS STANDARD SHEET OF NOTES SHALL GOVERN OVER THE SPECIFICATIONS, BUT THE REMAINDER OF THE PLANS SHALL GOVERN OVER NOTES HEREON, AND SPECIAL PROVISIONS SHALL GOVERN OVER ALL. SEE SPECIFICATIONS ARTICLE 105-4.

ENGLISH

JANUARY, 1990