

09/05/11

TIP PROJECT: B-4147

CONTRACT: C202842

See Sheet 1-A For Index of Sheets
See Sheet 1-B For Conventional Plan Sheet Symbols

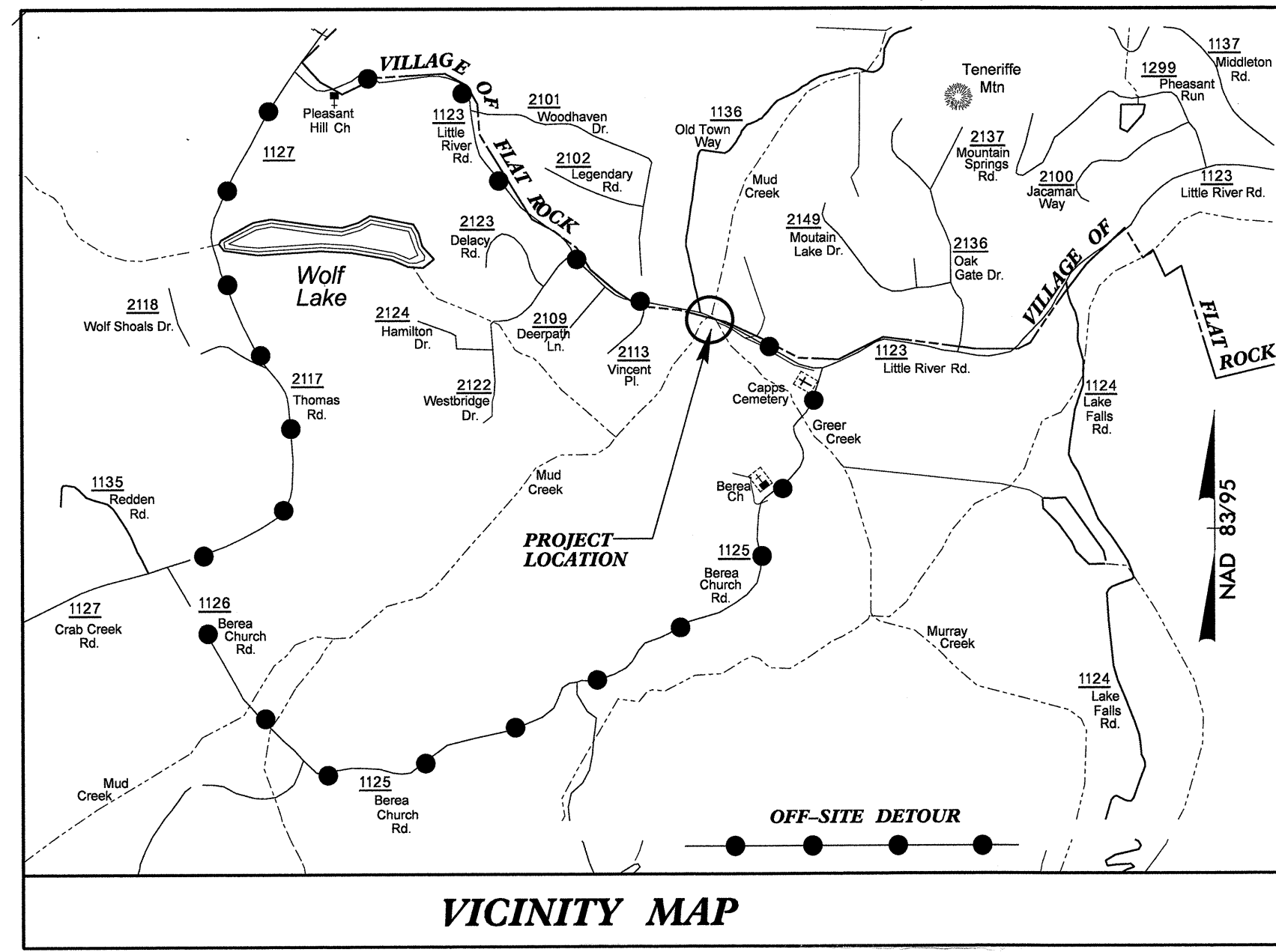

VICINITY MAP

STATE OF NORTH CAROLINA
DIVISION OF HIGHWAYS

HENDERSON COUNTY

LOCATION: BRIDGES NO. 75 & 76 OVER RIGHT PRONG MUD CREEK AND LEFT PRONG MUD CREEK ON SR 1123 (LITTLE RIVER ROAD)
TYPE OF WORK: GRADING, DRAINAGE, PAVING, RETAINING WALLS & STRUCTURES

| STATE | STATE PROJECT REFERENCE NO. | SHEET NO. | TOTAL SHEETS |
|-----------------|-----------------------------|-------------|--------------|
| N.C. | B-4147 | 1 | |
| STATE PROJ. NO. | F.A. PROJ. NO. | DESCRIPTION | |
| 33496.1.1 | BRZ-1123(11) | PE | |
| 33496.2.1 | BRZ-1123(11) | R/W & UTIL. | |
| 33496.3.1 | BRZ-1123(11) | CONST. | |

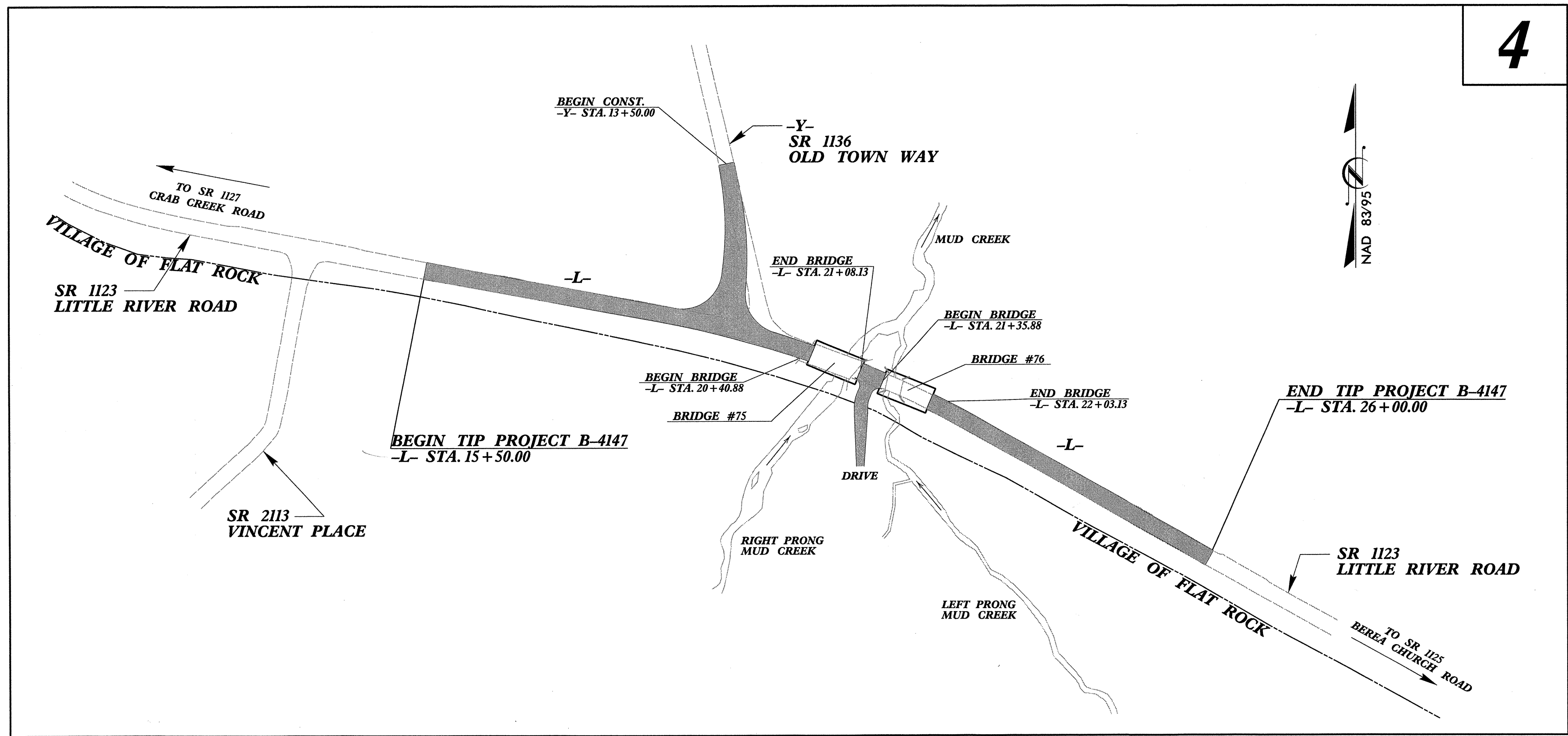

4

GRAPHIC SCALES

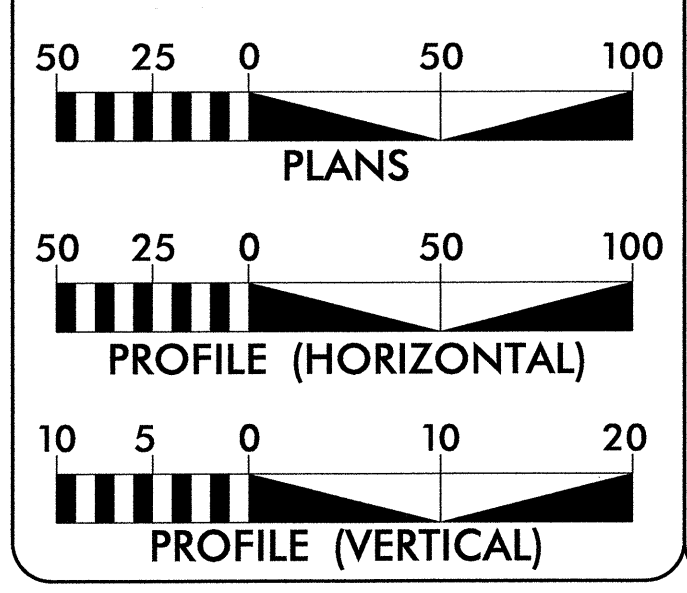

DESIGN DATA

ADT 2013 = 1785
ADT 2033 = 3710
DHV = 12 %
D = 55 %
T = 7 % *
V = 40 MPH
* TTST 1% + DUAL 6%
CLASSIFICATION: RURAL LOCAL
SUBREGIONAL TIER DESIGN

PROJECT LENGTH

TOTAL ROADWAY LENGTH TIP PROJECT B-4147 = 0.174mi
TOTAL STRUCTURE LENGTH TIP PROJECT B-4147 = 0.025mi
TOTAL LENGTH TIP PROJECT B-4147 = 0.199mi

Prepared for the North Carolina Department of Transportation in the Office of:
WETHERILL ENGINEERING
559 JONES FRANKLIN ROAD
SUITE 164
RALEIGH, N.C. 27606
LICENSE NO. F-6377
PHONE: 919 851 8077
FAX: 919 851 8107

2012 STANDARD SPECIFICATIONS

RIGHT OF WAY DATE: JUNE 17, 2011
LETTING DATE: JANUARY 15, 2013

NCDOT CONTACT: BRENDA L. MOORE, PE
PROJECT ENGINEER-ROADWAY DESIGN

EDWARD G. WETHERILL, PE
PROJECT ENGINEER
BOB A. MAY, PE
PROJECT DESIGN ENGINEER

HYDRAULICS ENGINEER
ROADWAY DESIGN ENGINEER

Signature: *Bob A. May*
SIGNATURE: Bob A. May
P.E. 10/16/12

Signature: *Edward G. Wetherill*
SIGNATURE: Edward G. Wetherill
P.E. 10/17/12

Professional Engineer Seals for Edward G. Wetherill and Bob A. May.

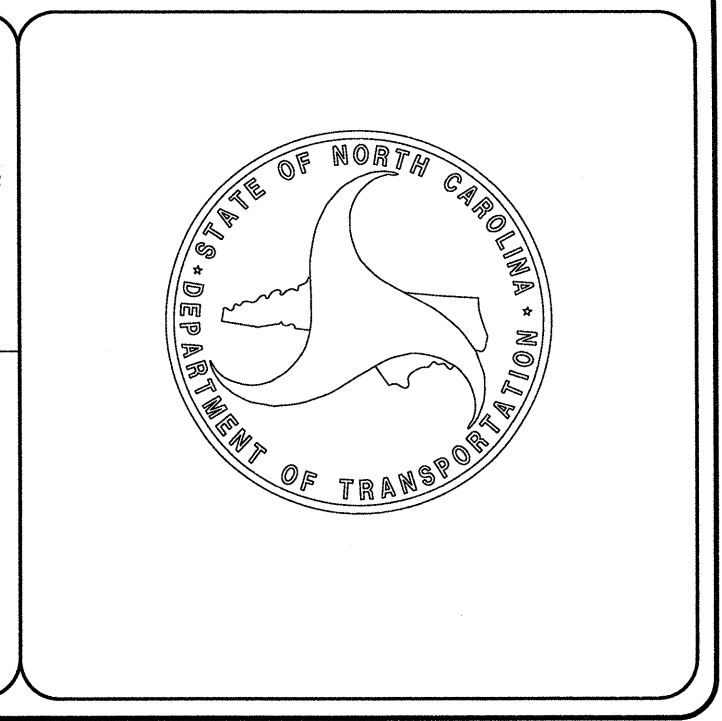

9:18:37 AM
P:\2009\B-4147\Roadway\Proj\B4147_Rdy_tsh.dgn
10/16/2012

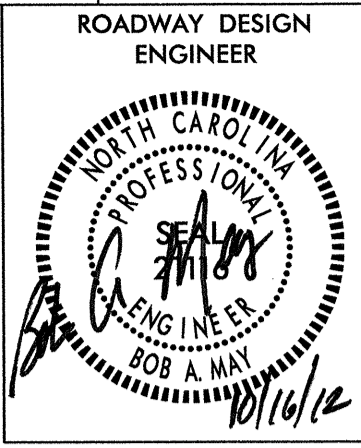

GENERAL NOTES

GENERAL NOTES: 2012 SPECIFICATIONS EFFECTIVE: 01-17-12
REVISED: 11/01/11

GRADING AND SURFACING OR RESURFACING AND WIDENING:
THE GRADE LINES SHOWN DENOTE THE FINISHED ELEVATION OF THE PROPOSED SURFACING AT GRADE POINTS SHOWN ON THE TYPICAL SECTIONS. WHERE NO GRADE LINES ARE SHOWN, THE PROFILES SHOWN DENOTE THE TOP ELEVATION OF THE EXISTING PAVEMENT ALONG THE CENTER LINE OF SURVEY ON WHICH THE PROPOSED RESURFACING WILL BE PLACED. GRADE LINES MAY BE ADJUSTED BY THE ENGINEER IN ORDER TO SECURE A PROPER TIE-IN.

CLEARING:
CLEARING ON THIS PROJECT SHALL BE PERFORMED TO THE LIMITS ESTABLISHED BY METHOD II.

SUPERELEVATION:
ALL CURVES ON THIS PROJECT SHALL BE SUPERELEVATED IN ACCORDANCE WITH STD. NO. 225.04 USING THE RATE OF SUPERELEVATION AND RUNOFF SHOWN ON THE PLANS. SUPERELEVATION IS TO BE REVOLVED ABOUT THE GRADE POINTS SHOWN ON THE TYPICAL SECTIONS.

SHOULDER CONSTRUCTION:
ASPHALT, EARTH, AND CONCRETE SHOULDER CONSTRUCTION ON THE HIGH SIDE OF SUPERELEVATED CURVES SHALL BE IN ACCORDANCE WITH STD. NO. 560.01.

SIDE ROADS:
THE CONTRACTOR WILL BE REQUIRED TO DO ALL NECESSARY WORK TO PROVIDE SUITABLE CONNECTIONS WITH ALL ROADS, STREETS, AND DRIVES ENTERING THIS PROJECT. THIS WORK WILL BE PAID FOR AT THE CONTRACT UNIT PRICE FOR THE PARTICULAR ITEMS INVOLVED.

UNDERDRAINS:
UNDERDRAINS SHALL BE CONSTRUCTED IN ACCORDANCE WITH STD. NO. 815.03 AT LOCATIONS DIRECTED BY THE ENGINEER.

GUARDRAIL:
THE GUARDRAIL LOCATIONS SHOWN ON THE PLANS MAY BE ADJUSTED DURING CONSTRUCTION AS DIRECTED BY THE ENGINEER. THE CONTRACTOR SHOULD CONSULT WITH THE ENGINEER PRIOR TO ORDERING GUARDRAIL MATERIAL.

TEMPORARY SHORING:
SHORING REQUIRED FOR THE MAINTENANCE OF TRAFFIC WILL BE PAID FOR AS "EXTRA WORK" IN ACCORDANCE WITH SECTION 104-7.

SUBSURFACE PLANS:
NO SUBSURFACE PLANS ARE AVAILABLE ON THIS PROJECT. THE CONTRACTOR SHOULD MAKE HIS OWN INVESTIGATION AS TO THE SUBSURFACE CONDITIONS.

END BENTS:
THE ENGINEER SHALL CHECK THE STRUCTURE END BENT PLANS, DETAILS, AND CROSS-SECTION PRIOR TO SETTING OF THE SLOPE STAKES FOR THE EMBANKMENT OR EXCAVATION APPROACHING A BRIDGE.

UTILITIES:
UTILITY OWNERS ON THIS PROJECT ARE Duke Power, AT&T Telephone, Public Service Gas, City of Hendersonville, Mediacom AND Utilities, Inc.
ANY RELOCATION OF EXISTING UTILITIES WILL BE ACCOMPLISHED BY OTHERS, EXCEPT AS SHOWN ON THE PLANS.

RIGHT-OF-WAY MARKERS:
ALL RIGHT-OF-WAY MARKERS ON THIS PROJECT SHALL BE PLACED BY OTHERS.

LIST OF ROADWAY STANDARD DRAWINGS

2012 ROADWAY ENGLISH STANDARD DRAWINGS
The following Roadway Standards as appear in "Roadway Standard Drawings" Highway Design Branch - N. C. Department of Transportation - Raleigh, N. C., Dated January, 2012 are applicable to this project and by reference hereby are considered a part of these plans:

| STD.NO. | TITLE |
|---|---|
| DIVISION 2 - EARTHWORK | |
| 200.02 | Method of Clearing - Method II |
| 225.02 | Guide for Grading Subgrade - Secondary and Local |
| 225.04 | Method of Obtaining Superelevation - Two Lane Pavement |
| DIVISION 3 - PIPE CULVERTS | |
| 300.01 | Method of Pipe Installation |
| 310.10 | Driveway Pipe Construction |
| DIVISION 4 - MAJOR STRUCTURES | |
| 422.11 | Reinforced Bridge Approach Fills - Sub Regional Tier |
| DIVISION 5 - SUBGRADE, BASES AND SHOULDERS | |
| 560.01 | Method of Shoulder Construction - High Side of Superelevated Curve - Method I |
| DIVISION 8 - INCIDENTALS | |
| 815.03 | Pipe Underdrain and Blind Drain |
| 840.00 | Concrete Base Pad for Drainage Structures |
| 840.18 | Concrete Grated Drop Inlet Type 'B' - 12" thru 36" Pipe |
| 840.24 | Frames and Narrow Slot Sag Grates |
| 840.27 | Brick Grated Drop Inlet Type 'B' - 12" thru 36" Pipe |
| 840.29 | Frames and Narrow Slot Flat Grates |
| 840.35 | Traffic Bearing Grated Drop Inlet - for Cast Iron Double Frame and Grates |
| 840.45 | Precast Drainage Structure |
| 840.46 | Traffic Bearing Precast Drainage Structure |
| 840.66 | Drainage Structure Steps |
| 846.01 | Concrete Curb, Gutter and Curb & Gutter |
| 846.04 | Drop Inlet Installation in Shoulder Berm Gutter |
| 850.01 | Concrete Paved Ditches |
| 862.01 | Guardrail Placement |
| 862.02 | Guardrail Installation |
| 862.03 | Structure Anchor Units |
| 876.01 | Rip Rap in Channels |
| 876.02 | Guide for Rip Rap at Pipe Outlets |
| 876.04 | Drainage Ditches with Class 'B' Rip Rap |

INDEX OF SHEETS

| Sheet Number | Sheet |
|--------------------|--|
| 1 | Title Sheet |
| 1-A | Index of Sheets, General Notes and list of Standards |
| 1-B | Conventional Symbols |
| 1-C | Survey Control Sheets |
| 2 | Typical Sections, Pavement Schedule and Miscellaneous Details not covered by Roadway Standards |
| 3 Thru 3-B | Summary of Quantities, Summary of Drainage, Summary of Guardrail, Summary of Earthwork and Summary of Pavement Removal |
| 4 Thru 5 | Plan and Profile Sheets |
| TMP-1 Thru TMP-5 | Traffic Control Plans |
| PMP-1 Thru PMP-2 | Pavement Marking Plans |
| EC-1 Thru EC-5 | Erosion Control Plans |
| SIGN-1 Thru SIGN-3 | Signing Plans |
| UC-1 Thru UC-5 | Utility Construction Plans |
| UO-1 Thru UO-2 | Utilities by Others Plans |
| X-1A | Cross-Section Summary Sheet |
| X-1 Thru X-16 | Cross-Sections |
| S-1 Thru S-39 | Structure Plans |
| W-1 Thru W-4 | Retaining Wall Plans |















B:17/99
 I:\3250 PM
 F:\2009\B-4147\Roadway\Proj\B4147_Rdwy_tsh.dgn
 10/15/2012

Note: Not to Scale











*S.U.E. = Subsurface Utility Engineering

CONVENTIONAL PLAN SHEET SYMBOLS











BOUNDARIES AND PROPERTY:

| | |
|--|--|
| State Line | _____ |
| County Line | _____ |
| Township Line | _____ |
| City Line | _____ |
| Reservation Line | _____ |
| Property Line | _____ |
| Existing Iron Pin | _____  |
| Property Corner | _____  |
| Property Monument | _____  |
| Parcel/Sequence Number | _____  |
| Existing Fence Line | _____  |
| Proposed Woven Wire Fence | _____  |
| Proposed Chain Link Fence | _____  |
| Proposed Barbed Wire Fence | _____  |
| Existing Wetland Boundary | _____  |
| Proposed Wetland Boundary | _____  |
| Existing Endangered Animal Boundary | _____  |
| Existing Endangered Plant Boundary | _____  |
| Known Soil Contamination: Area or Site | _____  |
| Potential Soil Contamination: Area or Site | _____  |





BUILDINGS AND OTHER CULTURE:

| | |
|-------------------------------|---|
| Gas Pump Vent or U/G Tank Cap | _____  |
| Sign | _____  |
| Well | _____  |
| Small Mine | _____  |
| Foundation | _____  |
| Area Outline | _____  |
| Cemetery | _____  |
| Building | _____  |
| School | _____  |
| Church | _____  |
| Dam | _____  |



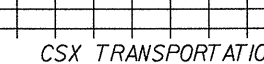

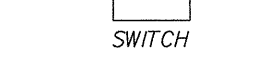







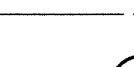

HYDROLOGY:

| | |
|------------------------------------|---|
| Stream or Body of Water | _____ |
| Hydro, Pool or Reservoir | _____  |
| Jurisdictional Stream | _____  |
| Buffer Zone 1 | _____  |
| Buffer Zone 2 | _____  |
| Flow Arrow | _____  |
| Disappearing Stream | _____  |
| Spring | _____  |
| Wetland | _____  |
| Proposed Lateral, Tail, Head Ditch | _____  |
| False Sump | _____  |

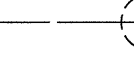
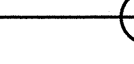
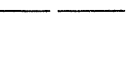



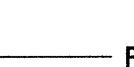
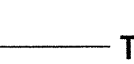
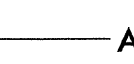





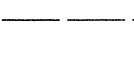

RAILROADS:

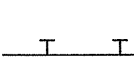
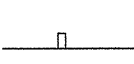
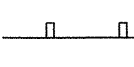
| | |
|--------------------|---|
| Standard Gauge | _____  |
| RR Signal Milepost | _____  |
| Switch | _____  |
| RR Abandoned | _____  |
| RR Dismantled | _____  |

RIGHT OF WAY:



| | |
|---|---|
| Baseline Control Point | _____  |
| Existing Right of Way Marker | _____  |
| Existing Right of Way Line | _____  |
| Proposed Right of Way Line | _____  |
| Proposed Right of Way Line with Iron Pin and Cap Marker | _____  |
| Proposed Right of Way Line with Concrete or Granite RW Marker | _____  |
| Proposed Control of Access Line with Concrete CA Marker | _____  |
| Existing Control of Access | _____  |
| Proposed Control of Access | _____  |
| Existing Easement Line | _____  |
| Proposed Temporary Construction Easement | _____  |
| Proposed Temporary Drainage Easement | _____  |
| Proposed Permanent Drainage Easement | _____  |
| Proposed Permanent Drainage / Utility Easement | _____  |
| Proposed Permanent Utility Easement | _____  |
| Proposed Temporary Utility Easement | _____  |
| Proposed Aerial Utility Easement | _____  |
| Proposed Permanent Easement with Iron Pin and Cap Marker | _____  |

ROADS AND RELATED FEATURES:

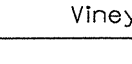



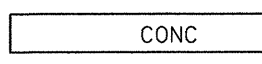
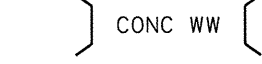
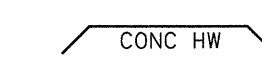
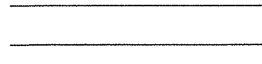
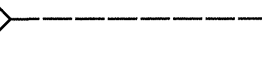
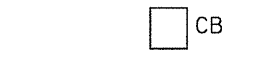

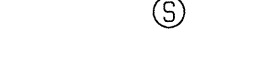
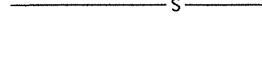
| | |
|----------------------------|---|
| Existing Edge of Pavement | _____  |
| Existing Curb | _____  |
| Proposed Slope Stakes Cut | _____  |
| Proposed Slope Stakes Fill | _____  |
| Proposed Curb Ramp | _____  |
| Existing Metal Guardrail | _____  |
| Proposed Guardrail | _____  |
| Existing Cable Guiderail | _____  |
| Proposed Cable Guiderail | _____  |
| Equality Symbol | _____  |
| Pavement Removal | _____  |
| VEGETATION: | |
| Single Tree | _____  |
| Single Shrub | _____  |
| Hedge | _____  |
| Woods Line | _____  |

| | |
|----------|---|
| Orchard | _____  |
| Vineyard | _____  |

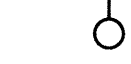

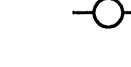
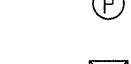
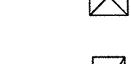

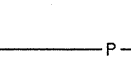
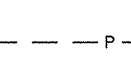

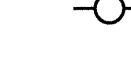
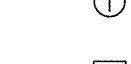
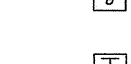

EXISTING STRUCTURES:

| | |
|--|---|
| MAJOR: | |
| Bridge, Tunnel or Box Culvert | _____  |
| Bridge Wing Wall, Head Wall and End Wall | _____  |
| MINOR: | |
| Head and End Wall | _____  |
| Pipe Culvert | _____  |
| Footbridge | _____  |
| Drainage Box: Catch Basin, DI or JB | _____  |
| Paved Ditch Gutter | _____  |
| Storm Sewer Manhole | _____  |
| Storm Sewer | _____  |

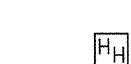
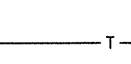

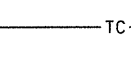



UTILITIES:

| | |
|-------------------------------------|---|
| POWER: | |
| Existing Power Pole | _____  |
| Proposed Power Pole | _____  |
| Existing Joint Use Pole | _____  |
| Proposed Joint Use Pole | _____  |
| Power Manhole | _____  |
| Power Line Tower | _____  |
| Power Transformer | _____  |
| U/G Power Cable Hand Hole | _____  |
| H-Frame Pole | _____  |
| Recorded U/G Power Line | _____  |
| Designated U/G Power Line (S.U.E.*) | _____  |









TELEPHONE:

| | |
|---|---|
| Existing Telephone Pole | _____  |
| Proposed Telephone Pole | _____  |
| Telephone Manhole | _____  |
| Telephone Booth | _____  |
| Telephone Pedestal | _____  |
| Telephone Cell Tower | _____  |
| U/G Telephone Cable Hand Hole | _____  |
| Recorded U/G Telephone Cable | _____  |
| Designated U/G Telephone Cable (S.U.E.*) | _____  |
| Recorded U/G Telephone Conduit | _____  |
| Designated U/G Telephone Conduit (S.U.E.*) | _____  |
| Recorded U/G Fiber Optics Cable | _____  |
| Designated U/G Fiber Optics Cable (S.U.E.*) | _____  |





WATER:

| | |
|-------------------------------------|---|
| Water Manhole | _____  |
| Water Meter | _____  |
| Water Valve | _____  |
| Water Hydrant | _____  |
| Recorded U/G Water Line | _____  |
| Designated U/G Water Line (S.U.E.*) | _____  |
| Above Ground Water Line | _____  |







TV:

| | |
|--|---|
| TV Satellite Dish | _____  |
| TV Pedestal | _____  |
| TV Tower | _____  |
| U/G TV Cable Hand Hole | _____  |
| Recorded U/G TV Cable | _____  |
| Designated U/G TV Cable (S.U.E.*) | _____  |
| Recorded U/G Fiber Optic Cable | _____  |
| Designated U/G Fiber Optic Cable (S.U.E.*) | _____  |













GAS:

| | |
|-----------------------------------|---|
| Gas Valve | _____  |
| Gas Meter | _____  |
| Recorded U/G Gas Line | _____  |
| Designated U/G Gas Line (S.U.E.*) | _____  |
| Above Ground Gas Line | _____  |

SANITARY SEWER:

| | |
|--|---|
| Sanitary Sewer Manhole | _____  |
| Sanitary Sewer Cleanout | _____  |
| U/G Sanitary Sewer Line | _____  |
| Above Ground Sanitary Sewer | _____  |
| Recorded SS Forced Main Line | _____  |
| Designated SS Forced Main Line (S.U.E.*) | _____  |

MISCELLANEOUS:

| | |
|--|---|
| Utility Pole | _____  |
| Utility Pole with Base | _____  |
| Utility Located Object | _____  |
| Utility Traffic Signal Box | _____  |
| Utility Unknown U/G Line | _____  |
| U/G Tank; Water, Gas, Oil | _____  |
| Underground Storage Tank, Approx. Loc. | _____  |
| A/G Tank; Water, Gas, Oil | _____  |
| Geoenvironmental Boring | _____  |
| U/G Test Hole (S.U.E.*) | _____  |
| Abandoned According to Utility Records | _____  |
| End of Information | _____  |

SURVEY CONTROL SHEET B-4147

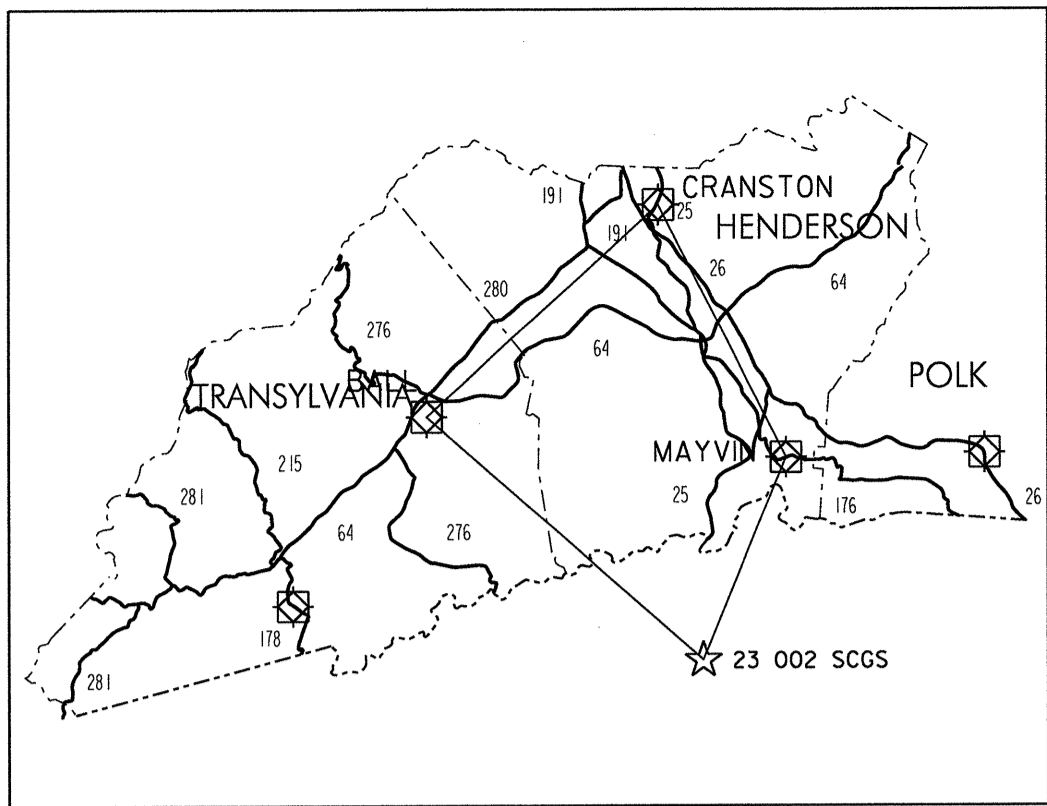

HARN VACINITY MAP

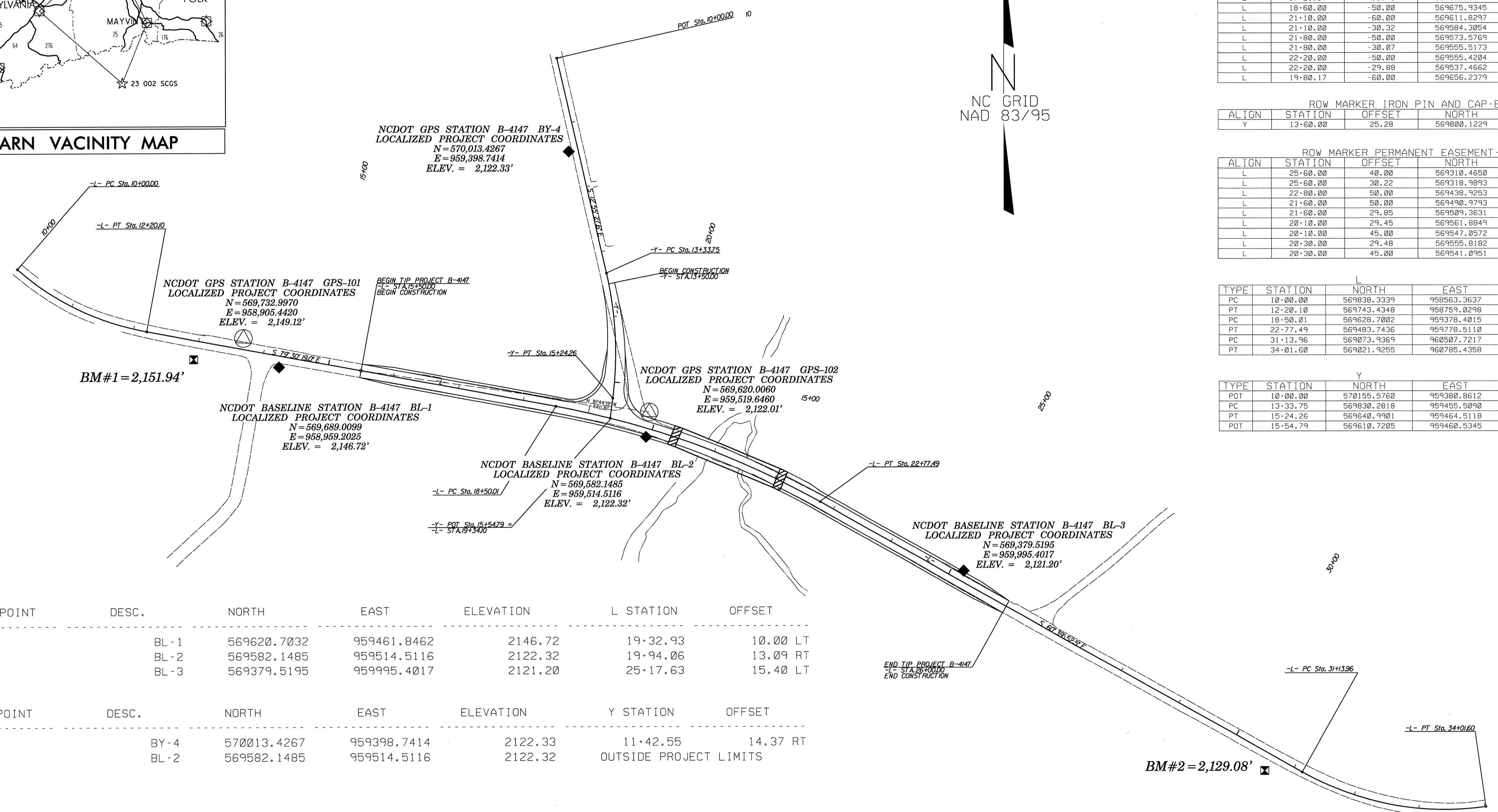

ROW MARKER IRON PIN AND CAP-E

| ALIGN | STATION | OFFSET | NORTH | EAST |
|-------|----------|--------|-------------|-------------|
| L | 17+21.57 | -30.43 | 569682.0197 | 959257.6559 |
| L | 18+60.00 | -50.00 | 569675.9345 | 959397.7047 |
| L | 21+10.00 | -60.00 | 569611.8297 | 959650.0556 |
| L | 21+10.00 | -30.32 | 569684.3054 | 959638.9610 |
| L | 21+80.00 | -50.00 | 569673.5769 | 959712.9742 |
| L | 21+80.00 | -30.07 | 569655.5173 | 959704.5380 |
| L | 22+20.00 | -50.00 | 569655.4204 | 959750.3326 |
| L | 22+20.00 | -29.88 | 569637.4662 | 959741.2626 |
| L | 19+80.17 | -60.00 | 569656.2379 | 959521.7581 |

ROW MARKER IRON PIN AND CAP-E

| ALIGN | STATION | OFFSET | NORTH | EAST |
|-------|----------|--------|-------------|-------------|
| Y | 13+60.00 | 25.28 | 569800.1229 | 959435.8602 |

ROW MARKER PERMANENT EASEMENT-E

| ALIGN | STATION | OFFSET | NORTH | EAST |
|-------|----------|--------|-------------|-------------|
| L | 25+60.00 | 40.00 | 569310.4650 | 960005.1976 |
| L | 25+60.00 | 30.22 | 569318.9893 | 960009.9881 |
| L | 22+80.00 | 50.00 | 569438.9253 | 959756.2037 |
| L | 21+60.00 | 50.00 | 569490.9793 | 959653.1657 |
| L | 21+60.00 | 29.85 | 569509.3631 | 959661.4112 |
| L | 20+10.00 | 29.45 | 569561.8849 | 959524.6518 |
| L | 20+10.00 | 45.00 | 569547.0572 | 959519.9635 |
| L | 20+30.00 | 29.48 | 569555.8182 | 959543.2330 |
| L | 20+30.00 | 45.00 | 569541.0951 | 959538.3274 |

L

| TYPE | STATION | NORTH | EAST |
|------|----------|-------------|-------------|
| PC | 10+00.00 | 569838.3339 | 958563.3637 |
| PT | 12+20.10 | 569743.4348 | 958759.0298 |
| PC | 18+50.01 | 569628.7002 | 959378.4015 |
| PT | 22+77.49 | 569483.7436 | 959778.5110 |
| PC | 31+13.96 | 569073.9369 | 960507.7217 |
| PT | 34+01.60 | 569021.9255 | 960795.4358 |

Y

| TYPE | STATION | NORTH | EAST |
|------|----------|-------------|-------------|
| POT | 10+00.00 | 570155.5760 | 959380.8612 |
| PC | 13+33.75 | 569830.2818 | 959455.5090 |
| PT | 15+24.26 | 569640.9901 | 959464.5118 |
| POT | 15+54.79 | 569610.7205 | 959460.5345 |

| BL POINT | DESC. | NORTH | EAST | ELEVATION | L STATION | OFFSET |
|----------|-------|-------------|-------------|-----------|-----------|----------|
| 1 | BL-1 | 569620.7032 | 959461.8462 | 2146.72 | 19+32.93 | 10.00 LT |
| 2 | BL-2 | 569582.1485 | 959514.5116 | 2122.32 | 19+94.06 | 13.09 RT |
| 3 | BL-3 | 569379.5195 | 959995.4017 | 2121.20 | 25+17.63 | 15.40 LT |

| BY POINT | DESC. | NORTH | EAST | ELEVATION | Y STATION | OFFSET |
|----------|-------|-------------|-------------|-----------|------------------------|----------|
| 4 | BY-4 | 570013.4267 | 959398.7414 | 2122.33 | 11+42.55 | 14.37 RT |
| Y2 | BL-2 | 569582.1485 | 959514.5116 | 2122.32 | OUTSIDE PROJECT LIMITS | |

DATUM DESCRIPTION

THE LOCALIZED COORDINATE SYSTEM DEVELOPED FOR THIS PROJECT IS BASED ON THE STATE PLANE COORDINATES ESTABLISHED BY NCDOT FOR MONUMENT "B4147 (GPS 102)" WITH NAD 83/95 STATE PLANE GRID COORDINATES OF NORTHING: 569620.0060(±) EASTING: 959519.6460(±) ELEVATION: 2122.01(±±)

THE AVERAGE COMBINED GRID FACTOR USED ON THIS PROJECT (GROUND TO GRID) IS: 0.99977615

THE N.C. LAMBERT GRID BEARING AND LOCALIZED HORIZONTAL GROUND DISTANCE FROM "B4147 (GPS 102)" TO -L- STATION 15+50.00 IS N81°44'19"W 440.81'

ALL LINEAR DIMENSIONS ARE LOCALIZED HORIZONTAL DISTANCES VERTICAL DATUM USED IS NAVD 88

 BM1 ELEVATION = 2151.94
 N 569701 E 958830
 L STATION 12+98 29 RIGHT
 NAIL IN BASE 18 IN. WHITE PINE

 BM2 ELEVATION = 2129.08
 N 569076 E 960451
 L STATION 30+63 26 RIGHT
 NAIL IN BASE 16 IN. WILD CHERRY

NOTES:

- THE CONTROL DATA FOR THIS PROJECT CAN BE FOUND ELECTRONICALLY BY SELECTING PROJECT CONTROL DATA AT:
[HTTP://WWW.NCDOT.ORG/DOH/PRECONSTRUCT/HIGHWAYLOCATION/PROJECT/](http://www.ncdot.org/DOH/PRECONSTRUCT/HIGHWAYLOCATION/PROJECT/)
 THE FILES TO BE FOUND ARE AS FOLLOWS:
 B-4147_LS_CONTROL.TXT

SITE CALIBRATION INFORMATION HAS NOT BEEN PROVIDED FOR THIS PROJECT. IF FURTHER INFORMATION IS NEEDED, PLEASE CONTACT THE LOCATION AND SURVEYS UNIT.

⊕ INDICATES GEODETIC CONTROL MONUMENTS USED OR SET FOR HORIZONTAL PROJECT CONTROL BY THE NCDOT LOCATION AND SURVEYS UNIT.
 PROJECT CONTROL ESTABLISHED USING GLOBAL POSITIONING SYSTEM.
 NETWORK ESTABLISHED FROM EXISTING HARN MONUMENTATION

NOTE: DRAWING NOT TO SCALE

6/2/09 9:23:00 AM I:\V\2010\B-4147\Roadway\Pro\B-4147-1s-1c.dgn

6/2/09

PAVEMENT SCHEDULE (FINAL PAVEMENT DESIGN)

| | |
|----|--|
| C1 | PROP. APPROX. 1 1/4" ASPHALT CONCRETE SURFACE COURSE, TYPE SF9.5A, AT AN AVERAGE RATE OF 137.5 LBS. PER SQ. YD. |
| C2 | PROP. APPROX. 2 1/2" ASPHALT CONCRETE SURFACE COURSE, TYPE SF9.5A, AT AN AVERAGE RATE OF 137.5 LBS. PER SQ. YD. IN EACH OF TWO LAYERS. |
| C3 | PROP. VAR. DEPTH ASPHALT CONCRETE SURFACE COURSE, TYPE SF9.5A, AT AN AVERAGE RATE OF 110 LBS. PER SQ. YD. PER 1" DEPTH. TO BE PLACED IN LAYERS NOT TO EXCEED 1 1/2" IN DEPTH. |
| D1 | PROP. APPROX. 2 1/2" ASPHALT CONCRETE INTERMEDIATE COURSE, TYPE I19.0B, AT AN AVERAGE RATE OF 285 LBS. PER SQ. YD. |
| D2 | PROP. VAR. DEPTH ASPHALT CONCRETE INTERMEDIATE COURSE, TYPE I19.0B, AT AN AVERAGE RATE OF 114 LBS. PER SQ. YD. PER 1" DEPTH, TO BE PLACED IN LAYERS NOT LESS THAN 2 1/2" IN DEPTH OR GREATER THAN 4" IN DEPTH. |
| E1 | PROP. APPROX. 4" ASPHALT CONCRETE BASE COURSE, TYPE B25.0B, AT AN AVERAGE RATE OF 456 LBS. PER SQ. YD. |
| E2 | PROP. VAR. DEPTH ASPHALT CONCRETE BASE COURSE, TYPE B25.0B, AT AN AVERAGE RATE OF 114 LBS. PER SQ. YD. PER 1" DEPTH. TO BE PLACED IN LAYERS NOT LESS THAN 3" IN DEPTH OR GREATER THAN 5 1/2" IN DEPTH. |
| J | 6" AGGREGATE BASE COURSE |
| R1 | SHOULDER BERM GUTTER |
| T | EARTH MATERIAL. |
| U | EXISTING PAVEMENT. |
| W | VARIABLE DEPTH ASPHALT PAVEMENT (SEE WEDGING DETAIL THIS SHEET) |

NOTE: PAVEMENT EDGE SLOPES ARE 1:1 UNLESS SHOWN OTHERWISE.

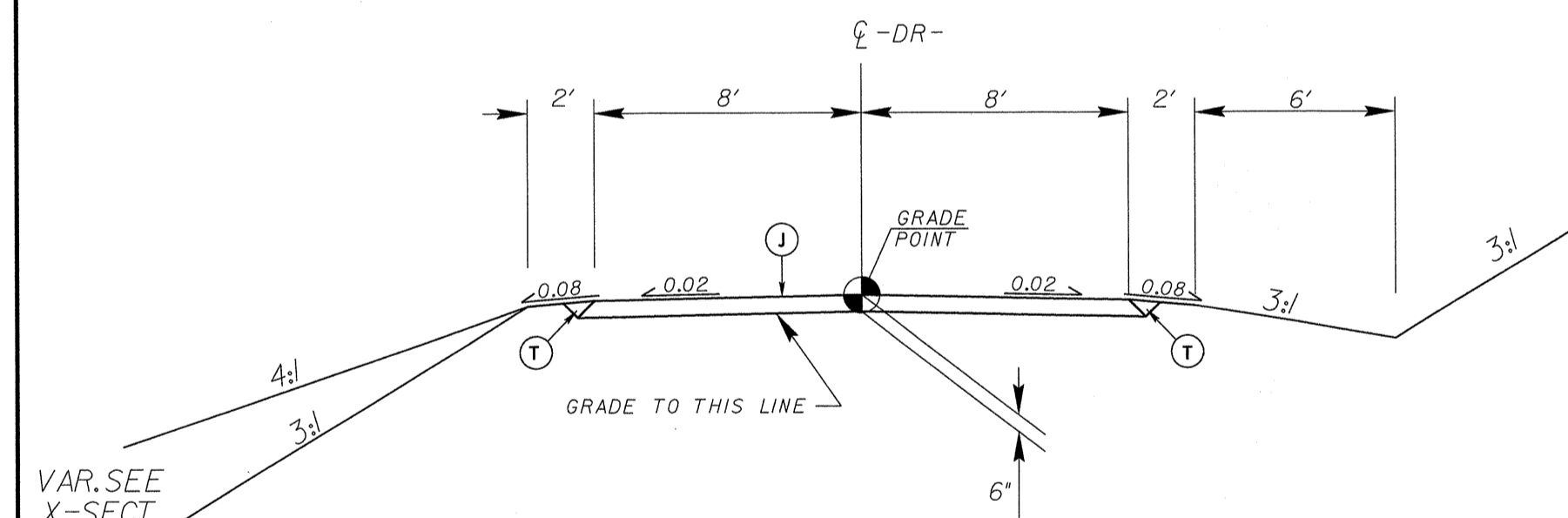

TYPICAL SECTION NO. 4

USE TYPICAL SECTION NO. 4:
-DR- STA. 10+29.61 TO -DR- STA. 11+15.00

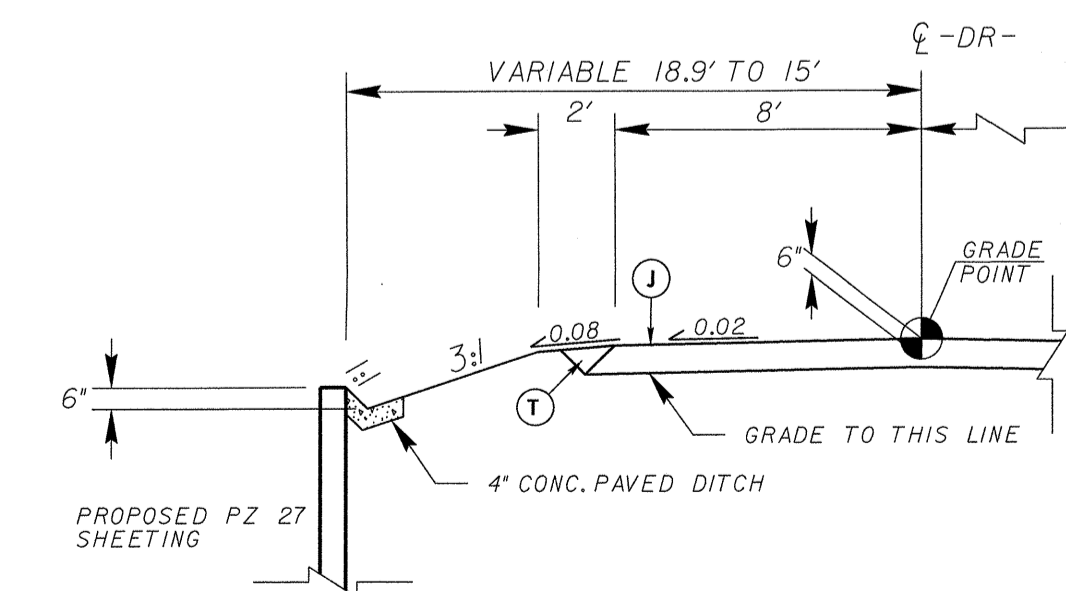

PARTIAL TYPICAL SECTION

USE IN CONJUNCTION WITH TYPICAL SECTION NO. 4
-DR- STA. 10+20.71 TO -DR- STA. 10+50.00 RT.
-DR- STA. 10+20.71 TO -DR- STA. 10+66.00 LT.

NOTE: UTILIZE MAINLINE PAVEMENT DESIGN TO BACK OF RADIUS POINT ALONG PROPOSED DRIVE.

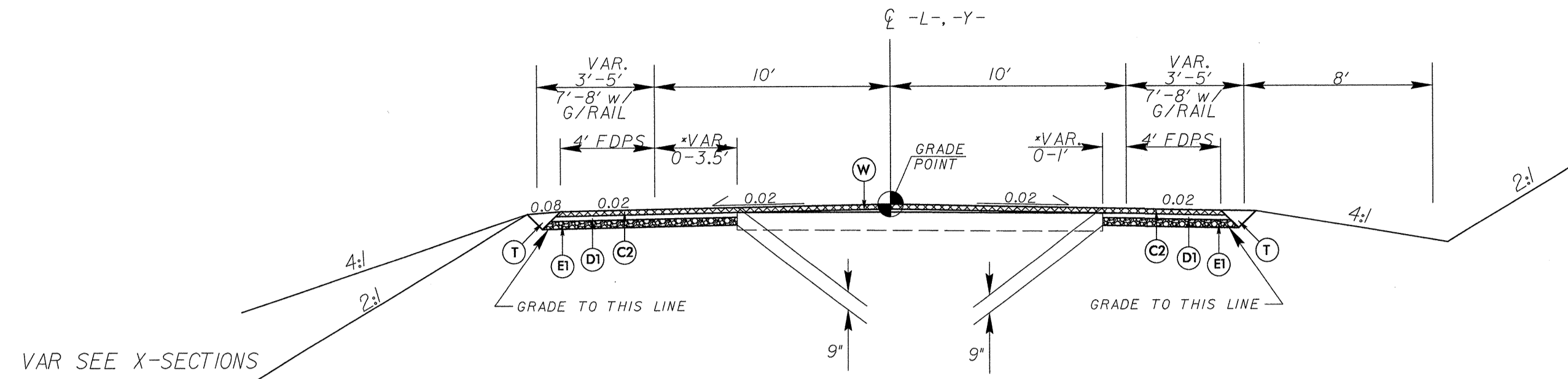

TYPICAL SECTION NO. 1

USE TYPICAL SECTION NO. 1:
FDPS = FULL DEPTH PAVED SHOULDER

-L- STA. 16+00.00 TO -L- STA. 18+18.43
-L- STA. 23+58.92 TO -L- STA. 25+50.00
*-Y- STA. 13+50.00 TO -Y- STA. 13+92.89

TRANSITION FROM EXISTING TO TYPICAL NO. 1
FROM -L- STA. 15+50.00 TO -L- STA. 16+00.00

TRANSITION FROM TYPICAL NO. 1 TO EXISTING
FROM -L- STA. 25+50.00 TO -L- STA. 26+00.00

* NOTE: PROJECTED ADT VOLUMES DO NOT WARRANT PAVED SHOULDERS FOR -Y- (ISR 1136 OLD TOWN WAY)

NOTE: INCIDENTAL MILLING IS TO BE UTILIZED AT PAVEMENT TIES.

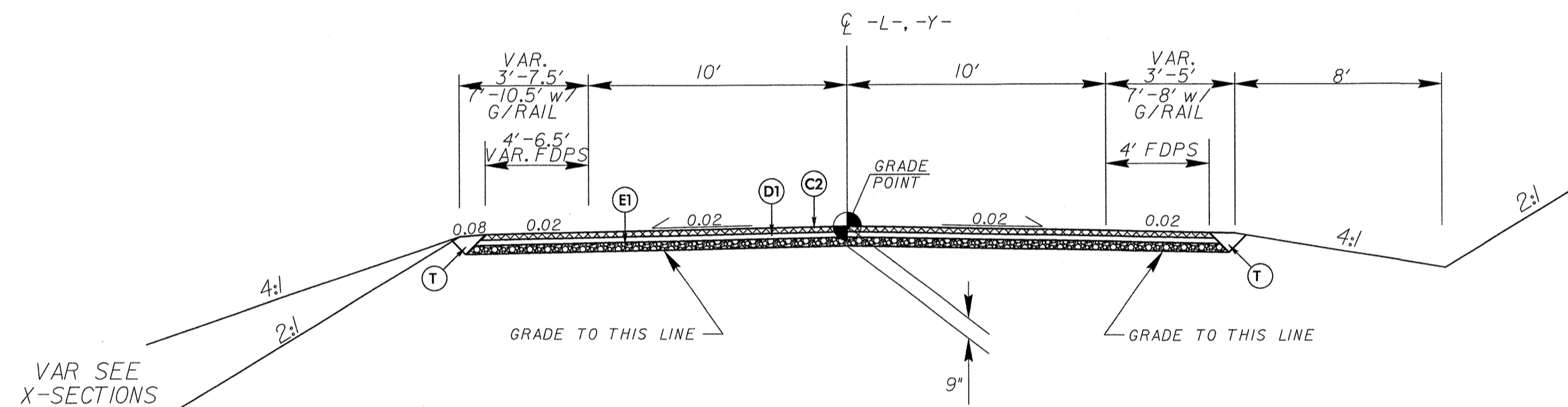

TYPICAL SECTION NO. 2

USE TYPICAL SECTION NO. 2:
FDPS = FULL DEPTH PAVED SHOULDER

-L- STA. 18+18.43 TO -L- STA. 20+40.88 (BEGIN BRIDGE)
-L- STA. 21+08.13 (END BRIDGE) TO -L- STA. 21+35.88 (BEGIN BRIDGE)
-L- STA. 22+03.13 (END BRIDGE) TO -L- STA. 23+58.92
*-Y- STA. 13+92.89 TO -Y- STA. 15+44.72

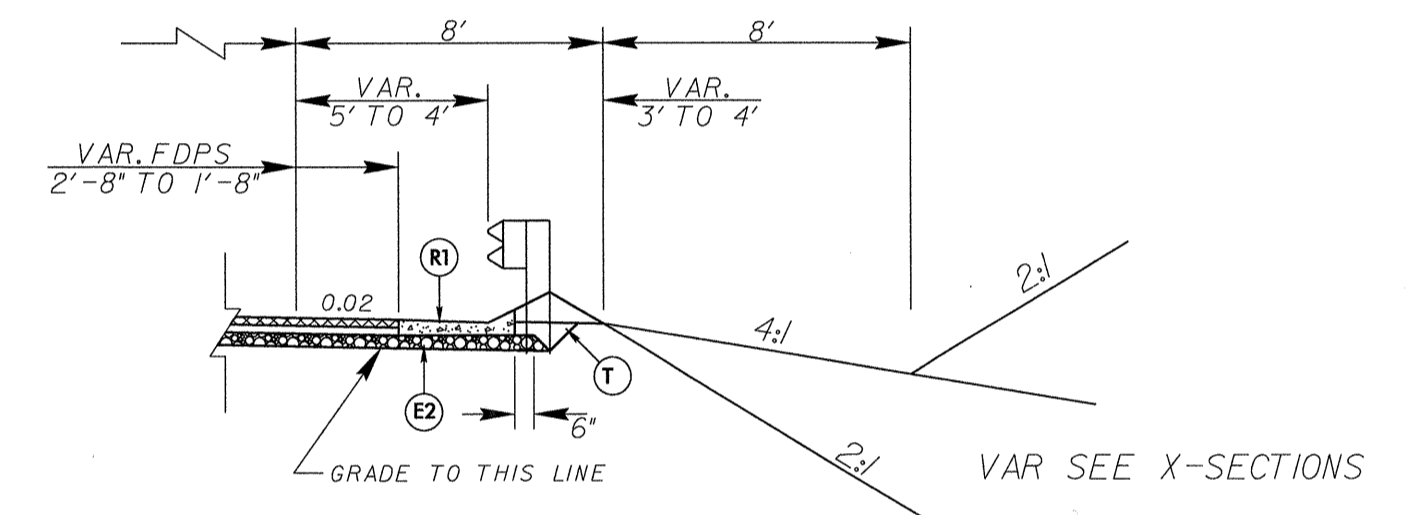

PARTIAL TYPICAL SECTION

USE IN CONJUNCTION WITH TYPICAL SECTION NO. 2

FDPS = FULL DEPTH PAVED SHOULDER
-L- STA. 19+26.00 TO -L- STA. 20+29.05
-L- STA. 22+14.96 TO -L- STA. 22+43.00

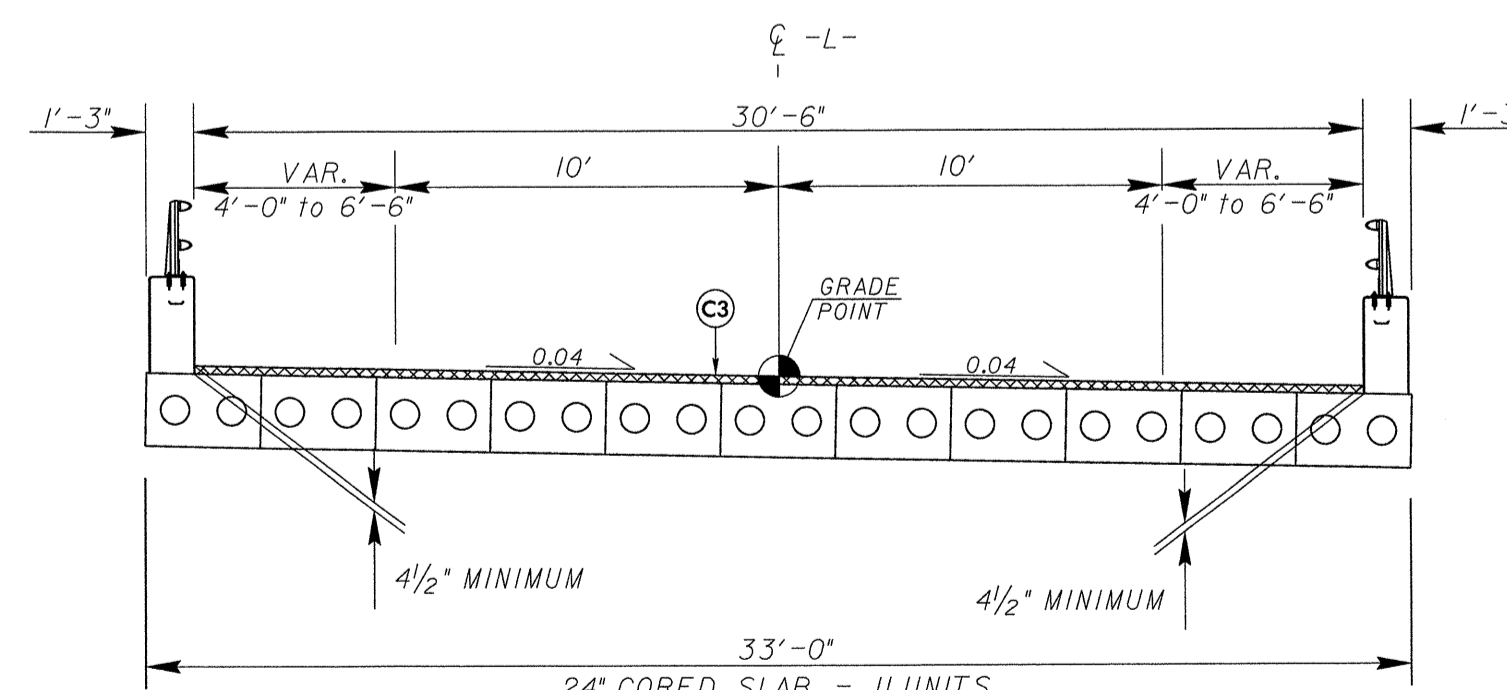

TYPICAL SECTION NO. 3

USE TYPICAL SECTION NO. 3:

-L- STA. 20+40.88 TO -L- STA. 21+08.13
-L- STA. 21+35.88 TO -L- STA. 22+03.13

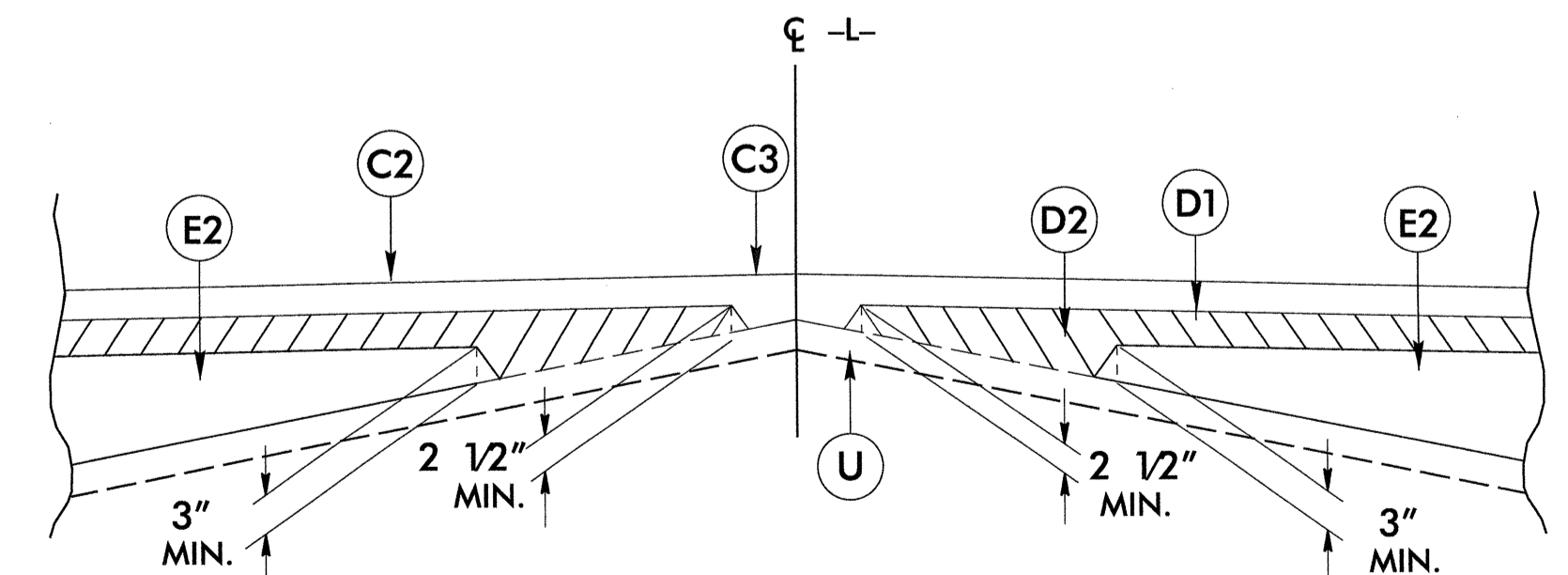

Detail Showing Method of Wedging

| | |
|---|------------------------------|
| PROJECT REFERENCE NO. B-4147 | SHEET NO. 2 |
| ROADWAY DESIGN ENGINEER | PAVEMENT DESIGN ENGINEER |
| 559 Jones Franklin Rd. Suite 164 Raleigh, N.C. 27606 License No. F-0377 Bus: 919 851 8077 Fax: 919 851 9107 | |
| TRANSPORTATION PLANNING/DESIGN - BRIDGE/STRUCTURE DESIGN CIVIL/SITE DESIGN - GIS/GPS - CONSTRUCTION OBSERVATION | |

9:30 AM 6/2/09 B-4147-Roadway\Pro\B4147_Rd\j_tup.dgn 10/16/2012

**STATE OF NORTH CAROLINA
DIVISION OF HIGHWAYS
ROADWAY SUMMARY OF QUANTITIES FOR CONTRACT - C202842**

| ItemNumber | Sec # | Quantity | Unit | Description |
|--------------|-------|----------|------|--|
| 0000100000-N | 800 | Lump Sum | | MOBILIZATION |
| 0030000000-N | SP | Lump Sum | | BRIDGE APPROACH FILL - SUB REGIONAL TIER, STATION ***** (20+74.50) |
| 0030000000-N | SP | Lump Sum | | BRIDGE APPROACH FILL - SUB REGIONAL TIER, STATION ***** (21+69.50) |
| 0050000000-E | 226 | 1 | ACR | SUPPLEMENTARY CLEARING & GRUBBING |
| 0057000000-E | 226 | 220 | CY | UNDERCUT EXCAVATION |
| 0063000000-N | SP | Lump Sum | | GRADING |
| 0106000000-E | 230 | 4,300 | CY | BORROW EXCAVATION |
| 0134000000-E | 240 | 70 | CY | DRAINAGE DITCH EXCAVATION |
| 0195000000-E | 265 | 100 | CY | SELECT GRANULAR MATERIAL |
| 0196000000-E | 270 | 300 | SY | GEOTEXTILE FOR SOIL STABILIZATION |
| 0318000000-E | 300 | 150 | TON | FOUNDATION CONDITIONING MATERIAL, MINOR STRUCTURES |
| 0320000000-E | 300 | 270 | SY | FOUNDATION CONDITIONING GEOTEXTILE |
| 0335200000-E | 305 | 52 | LF | 15" DRAINAGE PIPE |
| 0335850000-E | 305 | 2 | EA | *** DRAINAGE PIPE ELBOWS (15") |
| 0343000000-E | 310 | 20 | LF | 15" SIDE DRAIN PIPE |
| 0378000000-E | 310 | 120 | LF | 24" RC PIPE CULVERTS, CLASS III |
| 0995000000-E | 340 | 84 | LF | PIPE REMOVAL |
| 1099700000-E | 505 | 100 | TON | CLASS IV SUBGRADE STABILIZATION |
| 1121000000-E | 520 | 45 | TON | AGGREGATE BASE COURSE |
| 1220000000-E | 545 | 200 | TON | INCIDENTAL STONE BASE |
| 1330000000-E | 607 | 340 | SY | INCIDENTAL MILLING |
| 1489000000-E | 610 | 730 | TON | ASPHALT CONC BASE COURSE, TYPE B25 0B |
| 1498000000-E | 610 | 395 | TON | ASPHALT CONC INTERMEDIATE COURSE, TYPE 119.0B |

| ItemNumber | Sec # | Quantity | Unit | Description |
|--------------|-------|----------|------|----------------------------------|
| 6021000000-E | 1620 | 1.25 | TON | FERTILIZER FOR TEMPORARY SEEDING |
| 6024000000-E | 1622 | 200 | LF | TEMPORARY SLOPE DRAINS |
| 6029000000-E | SP | 400 | LF | SAFETY FENCE |
| 6030000000-E | 1630 | 410 | CY | SILT EXCAVATION |
| 6036000000-E | 1631 | 5,000 | SY | MATTING FOR EROSION CONTROL |
| 6037000000-E | SP | 50 | SY | COIR FIBER MAT |
| 6038000000-E | SP | 120 | SY | PERMANENT SOIL REINFORCEMENT MAT |
| 6042000000-E | 1632 | 60 | LF | 1/4" HARDWARE CLOTH |
| 6070000000-N | 1639 | 4 | EA | SPECIAL STILLING BASINS |
| 6071010000-E | SP | 100 | LF | WATTLE |
| 6071020000-E | SP | 35 | LB | POLYACRYLAMIDE (PAM) |
| 6071030000-E | 1640 | 200 | LF | COIR FIBER BAFFLE |
| 6071050000-E | SP | 5 | EA | *** SKIMMER (1-1/2") |
| 6084000000-E | 1660 | 1.5 | ACR | SEEDING & MULCHING |
| 6087000000-E | 1660 | 1 | ACR | MOWING |
| 6090000000-E | 1661 | 50 | LB | SEED FOR REPAIR SEEDING |
| 6093000000-E | 1661 | 0.25 | TON | FERTILIZER FOR REPAIR SEEDING |
| 6096000000-E | 1662 | 50 | LB | SEED FOR SUPPLEMENTAL SEEDING |
| 6108000000-E | 1665 | 1.5 | TON | FERTILIZER TOPDRESSING |
| 6114500000-N | 1667 | 10 | MHR | SPECIALIZED HAND MOWING |
| 6117000000-N | SP | 25 | EA | RESPONSE FOR EROSION CONTROL |

SUMMARY OF QUANTITIES - B-4147

| ItemNumber | Sec # | Quantity | Unit | Description |
|--------------|-------|----------|------|---|
| 1525000000-E | 610 | 590 | TON | ASPHALT CONC SURFACE COURSE, TYPE SF9.5A |
| 1575000000-E | 620 | 95 | TON | ASPHALT BINDER FOR PLANT MIX |
| 2022000000-E | 815 | 23 | CY | SUBDRAIN EXCAVATION |
| 2033000000-E | 815 | 17 | CY | SUBDRAIN FINE AGGREGATE |
| 2044000000-E | 815 | 100 | LF | 6" PERFORATED SUBDRAIN PIPE |
| 2070000000-N | 815 | 1 | EA | SUBDRAIN PIPE OUTLET |
| 2077000000-E | 815 | 6 | LF | 6" OUTLET PIPE |
| 2286000000-N | 840 | 3 | EA | MASONRY DRAINAGE STRUCTURES |
| 2366000000-N | 840 | 1 | EA | FRAME WITH TWO GRATES, STD 840.24 |
| 2367000000-N | 840 | 2 | EA | FRAME WITH TWO GRATES, STD 840.29 |
| 2556000000-E | 846 | 150 | LF | SHOULDER BERM GUTTER |
| 2619000000-E | 850 | 20 | SY | 4" CONCRETE PAVED DITCH |
| 3030000000-E | 862 | 250 | LF | STEEL BM GUARDRAIL |
| 3045000000-E | 862 | 75 | LF | STEEL BM GUARDRAIL, SHOP CURVED |
| 3150000000-N | 862 | 5 | EA | ADDITIONAL GUARDRAIL POSTS |
| 3165000000-N | SP | 3 | EA | GUARDRAIL ANCHOR UNITS, TYPE ***** (350, TL-2) |
| 3195000000-N | 862 | 1 | EA | GUARDRAIL ANCHOR UNITS, TYPE AT-1 |
| 3215000000-N | 862 | 4 | EA | GUARDRAIL ANCHOR UNITS, TYPE III |
| 3628000000-E | 876 | 12 | TON | RIP RAP, CLASS I |
| 3649000000-E | 876 | 16 | TON | RIP RAP, CLASS B |
| 3656000000-E | 876 | 976 | SY | GEOTEXTILE FOR DRAINAGE |
| 4072000000-E | 903 | 25 | LF | SUPPORTS, 3-LB STEEL U-CHANNEL |
| 4102000000-N | 904 | 2 | EA | SIGN ERECTION, TYPE E |
| 4116100000-N | 904 | 1 | EA | SIGN ERECTION, RELOCATE, TYPE **** (GROUND MOUNTED) (E) |

| ItemNumber | Sec # | Quantity | Unit | Description |
|--------------|-------|----------|------|---|
| 4155000000-N | 907 | 12 | EA | DISPOSAL OF SIGN SYSTEM, U-CHANNEL |
| 4400000000-E | 1110 | 568 | SF | WORK ZONE SIGNS (STATIONARY) |
| 4405000000-E | 1110 | 112 | SF | WORK ZONE SIGNS (PORTABLE) |
| 4410000000-E | 1110 | 145 | SF | WORK ZONE SIGNS (BARRICADE MOUNTED) |
| 4430000000-N | 1130 | 51 | EA | DRUMS |
| 4435000000-N | 1135 | 19 | EA | CONES |
| 4445000000-E | 1145 | 100 | LF | BARRICADES (TYPE III) |
| 4450000000-N | 1150 | 400 | HR | FLAGGER |
| 4516000000-N | 1180 | 19 | EA | SKINNY DRUM |
| 4650000000-N | 1251 | 30 | EA | TEMPORARY RAISED PAVEMENT MARKERS |
| 4810000000-E | 1205 | 22,758 | LF | PAINT PAVEMENT MARKING LINES (4") |
| 4905000000-N | 1253 | 25 | EA | SNOWPLOWABLE PAVEMENT MARKERS |
| 5325800000-E | 1510 | 1,120 | LF | 8" WATER LINE |
| 5546000000-E | 1515 | 2 | EA | 8" VALVE |
| 5672000000-N | 1515 | 2 | EA | RELOCATE FIRE HYDRANT |
| 5801000000-E | 1530 | 1,080 | LF | ABANDON 8" UTILITY PIPE |
| 5835700000-E | 1540 | 105 | LF | 16" ENCASMENT PIPE |
| 5871500000-E | 1550 | 35 | LF | TRENCHLESS INSTALLATION OF 8" IN SOIL |
| 5871510000-E | 1550 | 35 | LF | TRENCHLESS INSTALLATION OF 8" NOT IN SOIL |
| 6000000000-E | 1605 | 2,150 | LF | TEMPORARY SILT FENCE |
| 6006000000-E | 1610 | 330 | TON | STONE FOR EROSION CONTROL, CLASS A |
| 6009000000-E | 1610 | 270 | TON | STONE FOR EROSION CONTROL, CLASS B |
| 6012000000-E | 1610 | 190 | TON | SEDIMENT CONTROL STONE |
| 6015000000-E | 1615 | 2 | ACR | TEMPORARY MULCHING |
| 6018000000-E | 1620 | 100 | LB | SEED FOR TEMPORARY SEEDING |

12/06/07

COMPUTED BY: bam DATE: 4/6/2010
 CHECKED BY: DATE:

PROJECT REFERENCE NO. SHEET NO.
 B-4147 3-A

STATE OF NORTH CAROLINA
 DIVISION OF HIGHWAYS

SUMMARY OF EARTHWORK
 IN CUBIC YARDS

| STATION | STATION | UNCL. EXCAV. | EMBANK. + % | BORROW | WASTE |
|-------------------------------------|---------------|--------------|-------------|--------|-------|
| -L- 15+50.00 | -L- 20+40.88 | 187 | 1558 | 1371 | |
| -Y- 13+50.00 | -Y- 15+44.72 | 19 | 1038 | 1019 | |
| SUBTOTALS: | | 206 | 2596 | 2390 | |
| -L- 21+08.13 | -L- 21+35.88 | 6 | 247 | 241 | |
| -DR- 10+16.46 | -DR- 11+15.00 | 5 | 273 | 268 | |
| SUBTOTALS: | | 11 | 520 | 509 | |
| -L- 22+03.13 | -L- 26+00.00 | 138 | 1144 | 1006 | |
| SUBTOTALS: | | 138 | 1144 | 1006 | |
| PROJECT SUBTOTALS: | | 355 | 4260 | 3905 | |
| LOSS DUE TO CLEARING & GRUBBING | | (-10) | | 10 | |
| PROJECT TOTALS: | | 345 | 4260 | 3915 | |
| 5% TO REPLACE TOPSOIL ON BORROW PIT | | | | 196 | |
| GRAND TOTALS: | | 345 | | 4111 | |
| SAY: | | 400 | | 4300 | |

UNDERCUT EXCAVATION = 220 CY (GEOTECH MEMO DATED 9/30/2009)

APPROXIMATE QUANTITIES ONLY. UNCLASSIFIED EXCAVATION, FINE GRADING, CLEARING & GRUBBING, BREAKIN OF EXISTING PAVEMENT AND REMOVAL OF EXISTING PAVEMENT WILL BE PAID FOR AT THE LUMP SUM PRICE FOR "GRADING".

Earthwork quantities are calculated by the Roadway Design Unit. These earthwork quantities are based in part on subsurface data provided by the Geotechnical Engineering Unit.

SUMMARY OF BREAKING EXISTING ASPHALT PAVEMENT

| SURVEY LINE | STATION | STATION | LOCATION LT/RT/CL | YD ³ |
|-------------|----------|----------|-------------------|-----------------|
| -L- | 18+18.43 | 20+35.27 | CL | 504.54 |
| -L- | 21+02.36 | 21+42.49 | CL | 94.56 |
| -L- | 21+62.67 | 23+58.92 | CL | 429.52 |
| TOTAL: | | | | 1028.62 |
| SAY: | | | | 1050.00 |

SHOULDER BERM GUTTER SUMMARY

| SURVEY LINE | STATION | STATION | LENGTH |
|-------------|----------|----------|--------|
| -L- RT. | 19+26.00 | 20+29.05 | 103.05 |
| -L- RT. | 22+14.96 | 22+43.00 | 28.04 |
| -L- LT. | 20+22.00 | 20+30.35 | 8.35 |
| -L- LT. | 22+13.57 | 22+22.00 | 8.43 |
| TOTAL: | | | 147.87 |
| SAY: | | | 150.00 |

PAVEMENT REMOVAL SUMMARY

| SURVEY LINE | STATION | STATION | LOCATION LT/RT/CL | YD ³ |
|-------------|----------|----------|-------------------|-----------------|
| -Y- | 13+92.89 | 15+42.41 | LT | 386.43 |
| TOTAL: | | | | 386.43 |
| SAY: | | | | 400.00 |

9:56:04 AM 12/06/07 4147\Roadway\Proj\B4147_Rdy_sum.dgn 10/16/2012

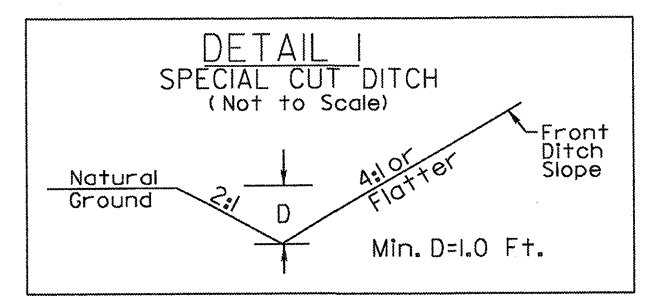

FROM STA. 16+50 TO STA. 18+00 RT. -L-

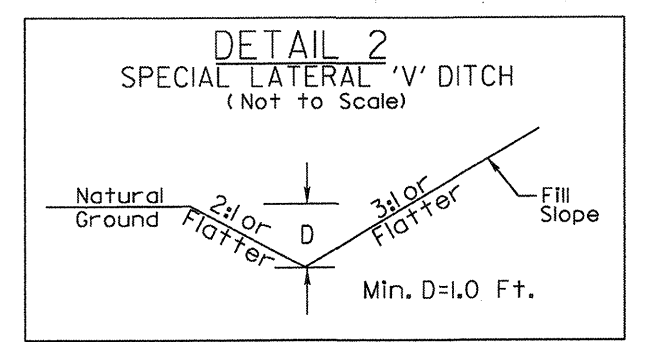

FROM STA. 14+00 TO STA. 15+00 RT. -Y-
 STA. 22+77.49 TO STA. 25+50 RT. -L-
 STA. 25+25.00 TO STA. 26+00 LT. -L-

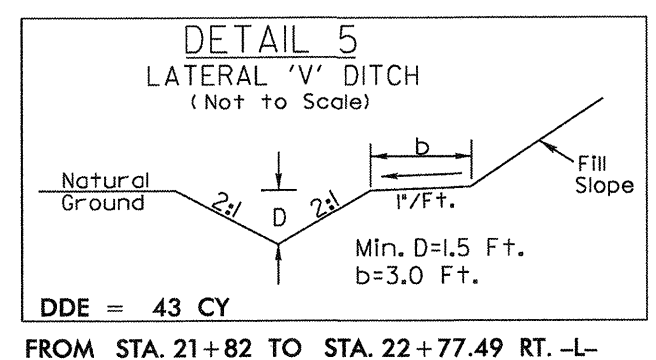

DDE = 43 CY
 FROM STA. 21+82 TO STA. 22+77.49 RT. -L-

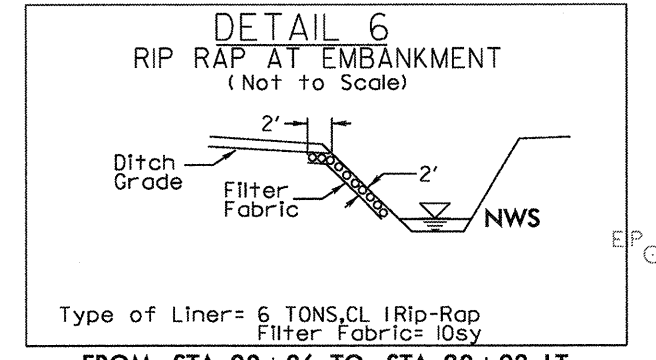

Type of Liner = 6 TONS CL Rip-Rap
 Filter Fabric: 10sy
 FROM STA. 20+86 TO STA. 20+98 LT
 FROM STA. 21+77 TO STA. 21+88 RT

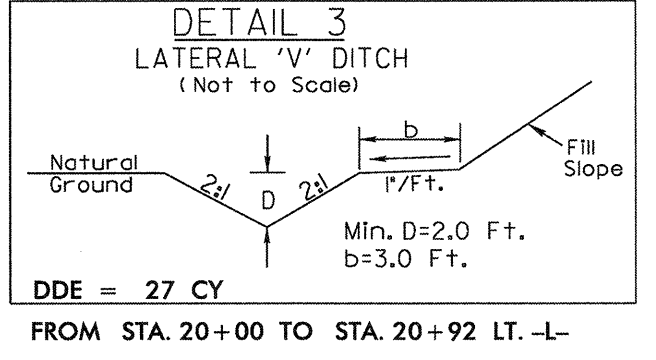

DDE = 27 CY
 FROM STA. 20+00 TO STA. 20+92 LT. -L-

| -L- | -Y- |
|--------------------------------------|--------------------------------------|
| PI Sta 20+65.70 | PI Sta 14+30.02 |
| $\Delta = 18^{\circ} 50' 26.5" (RT)$ | $\Delta = 20^{\circ} 24' 09.8" (RT)$ |
| D = 4' 24" 26.5" | D = 10' 42" 34.2" |
| L = 427.48' | L = 190.51' |
| T = 215.69' | T = 96.27' |
| R = 1,300.00' | R = 535.00' |
| SE = SEE PLANS | SE = SEE PLANS |
| RO = SEE PLANS | RO = SEE PLANS |
| V = 40mph | V = STOP CONDITION |

| -DR- |
|-------------------------------------|
| PI Sta 10+33.87 |
| $\Delta = 2^{\circ} 37' 45.3" (LT)$ |
| D = 190' 59" 09.4" |
| L = 11.33' |
| T = 5.73' |
| R = 30.00' |

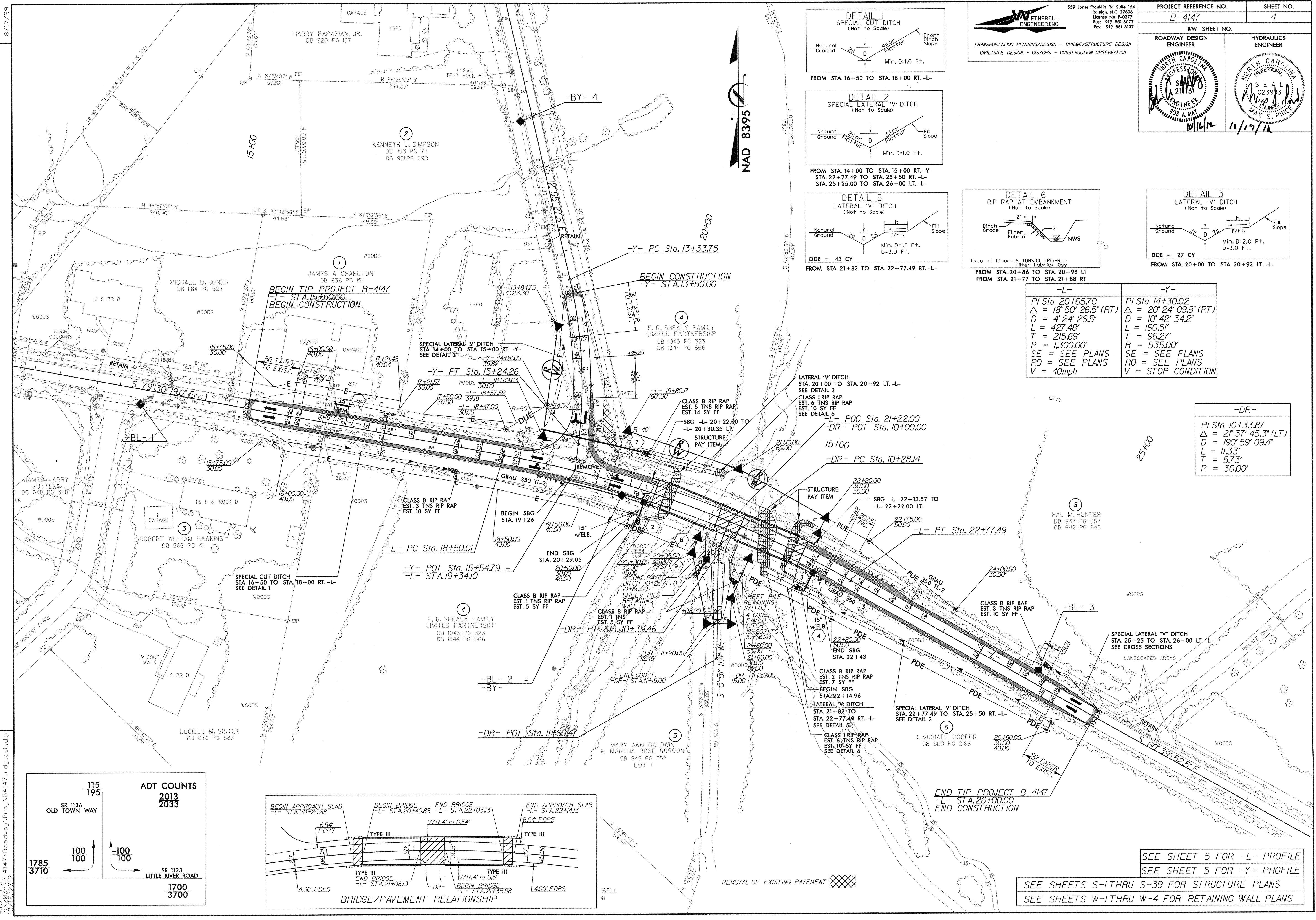

REVISIONS

| ADT COUNTS | |
|------------------------------|--------------|
| 2013 | |
| 2033 | |
| SR 1136 OLD TOWN WAY | 115 195 |
| SR 1123 LITTLE RIVER ROAD | 1700 3700 |
| SR 1123 LITTLE RIVER ROAD | 100 100 |
| SR 1123 LITTLE RIVER ROAD | 1785 3710 |

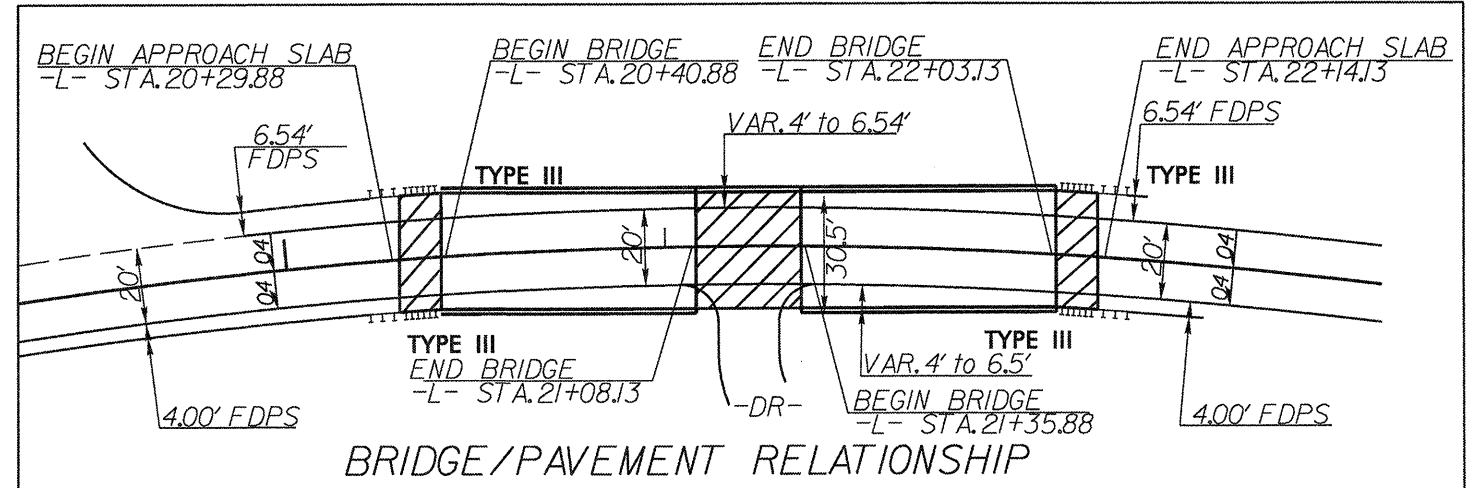

SEE SHEET 5 FOR -L- PROFILE
 SEE SHEET 5 FOR -Y- PROFILE
 SEE SHEETS S-1 THRU S-39 FOR STRUCTURE PLANS
 SEE SHEETS W-1 THRU W-4 FOR RETAINING WALL PLANS

8/17/09
 4:\28\B\B-417\Roadway\Proc\B417_r.dwg, psh,dwg
 10/16/2012

5/28/99

BM #1 N 569701 E 958830
NAIL IN BASE OF 18" WHITE PINE
-L- STA. 12+98 OFFSET = 29'
EL = 2151.94'

BM #2 N 569076 E 960451
NAIL IN BASE OF 16" WILD CHERRY
-L- STA. 30+63 OFFSET = 26'
EL = 2129.08'

WV ETHERILL ENGINEERING
559 Jones Franklin Rd. Suite 164
Raleigh, N.C. 27606
License No. F-0377
Bus: 919 851 8077
Fax: 919 851 8107

TRANSPORTATION PLANNING/DESIGN - BRIDGE/STRUCTURE DESIGN
CIVIL/SITE DESIGN - GIS/GPS - CONSTRUCTION OBSERVATION

| | |
|---------------------------------|---------------------|
| PROJECT REFERENCE NO. B-4147 | SHEET NO. 5 |
| ROADWAY DESIGN ENGINEER | HYDRAULICS ENGINEER |

Professional Engineer Seal: BOB A. HAY, No. 2116, State of North Carolina, expires 10/19/12.

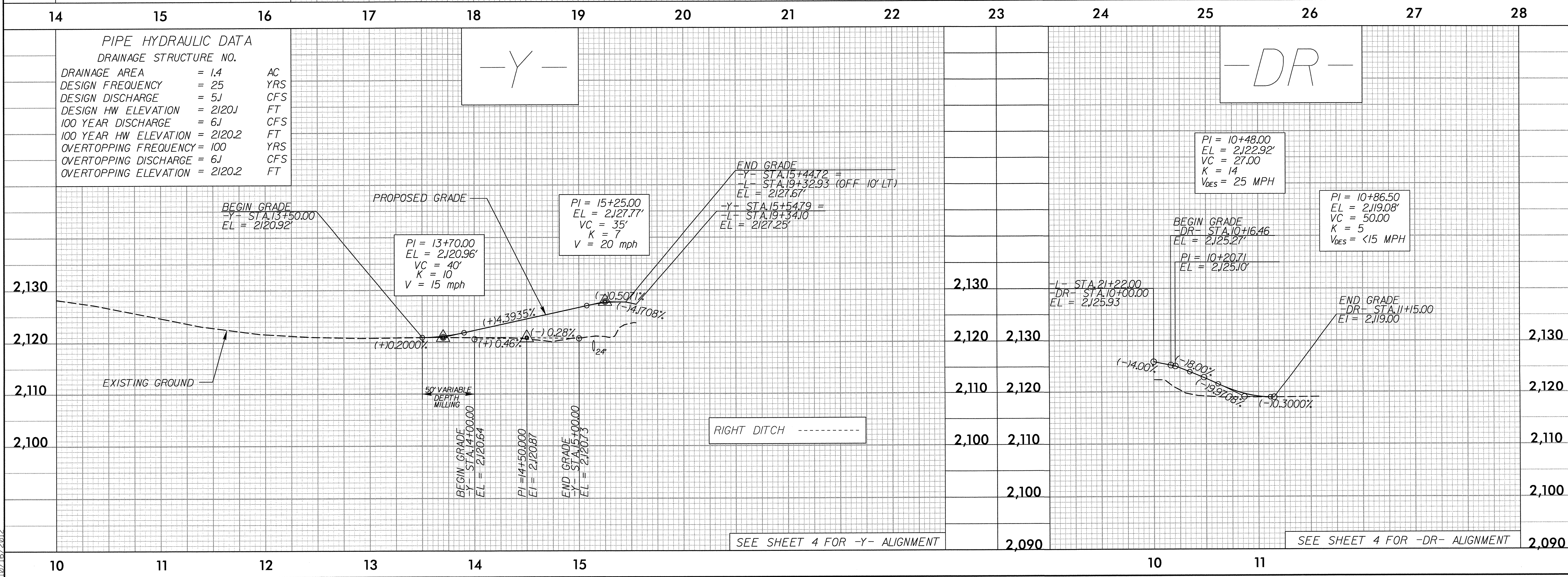
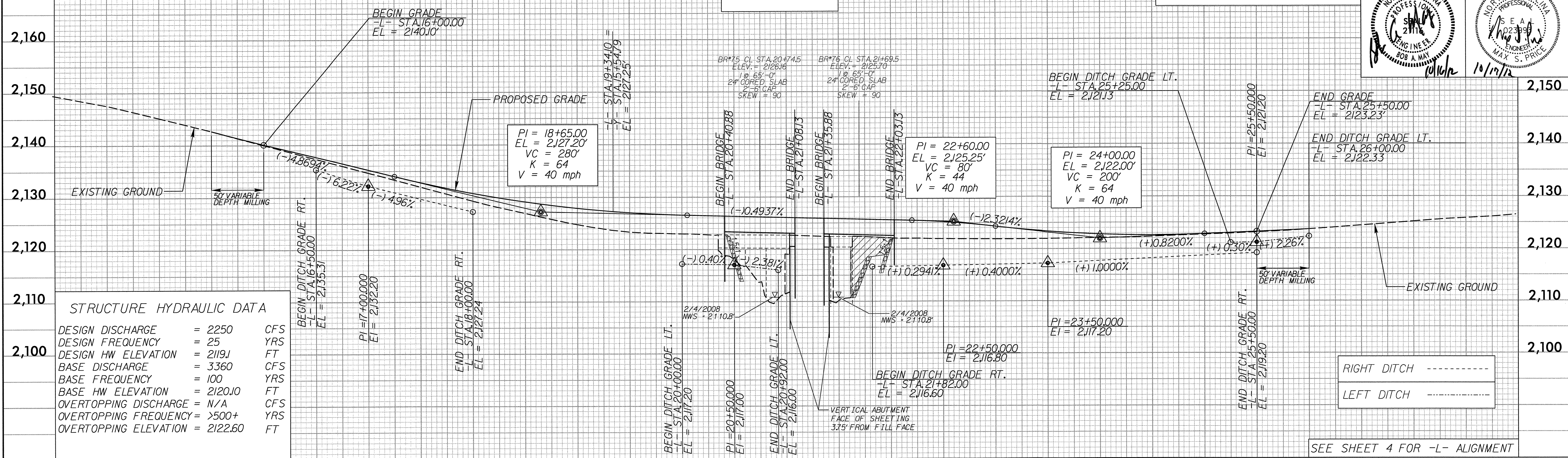

12:52:31 PM
5/28/2009
10/16/2012
P:\4147\Roadway\p-roj\B4147-Rdy-pl1.dgn