

STATE OF NORTH CAROLINA
DEPARTMENT OF TRANSPORTATION

TIP NO.	SHEET NO.
R-5000	PMP-1
APPROVED: <i>[Signature]</i>	
DATE: 7/3/12	
SEAL	

PAVEMENT MARKING PLAN
JACKSON COUNTY

LOCATION: NEW LOCATION CONNECTOR ROAD FROM NC 116 TO EAST OF NC 107
TYPE OF WORK: GRADING, DRAINAGE, PAVING CURB & GUTTER, AND STRUCTURE

T.I.P.: R-5000

ROADWAY STANDARD DRAWING

THE FOLLOWING ROADWAY STANDARDS AS APPEAR IN "ROADWAY STANDARD DRAWINGS" - PROJECT SERVICES UNIT - N.C. DEPARTMENT OF TRANSPORTATION - RALEIGH, N.C., DATED JANUARY 2012 ARE APPLICABLE TO THIS PROJECT AND BY REFERENCE HEREBY ARE CONSIDERED A PART OF THESE PLANS:

STD. NO.	TITLE
1205.01	PAVEMENT MARKINGS - LINE TYPES AND OFFSETS
1205.02	PAVEMENT MARKINGS - TWO-LANE AND MULTILANE ROADWAYS
1205.03	PAVEMENT MARKINGS - EXIT AND ENTRANCE RAMP
1205.04	PAVEMENT MARKINGS - INTERSECTIONS
1205.05	PAVEMENT MARKINGS - TURN LANES
1205.07	PAVEMENT MARKINGS - PEDESTRIAN CROSSWALKS
1205.08	PAVEMENT MARKINGS - SYMBOLS AND WORD MESSAGES
1205.09	PAVEMENT MARKINGS - PAINTED ISLANDS
1205.12	PAVEMENT MARKINGS - BRIDGES
1250.01	RAISED PAVEMENT MARKERS - INSTALLATION SPACING
1251.01	RAISED PAVEMENT MARKERS - PERMANENT AND TEMPORARY
1253.01	RAISED PAVEMENT MARKERS - SNOWPLOWABLE
1261.01	GUARDRAIL AND BARRIER DELINEATORS - INSTALLATION SPACING
1261.02	GUARDRAIL AND BARRIER DELINEATORS - TYPES AND MOUNTING
1262.01	GUARDRAIL END DELINEATION

GENERAL NOTES

THE FOLLOWING GENERAL NOTES APPLY AT ALL TIMES FOR THE DURATION OF THE CONSTRUCTION PROJECT, EXCEPT WHEN OTHERWISE NOTED IN THE PLAN, OR DIRECTED BY THE ENGINEER.

A) INSTALL PAVEMENT MARKINGS AND PAVEMENT MARKERS ON THE FINAL SURFACE AS FOLLOWS:

ROAD NAME	MARKING	MARKER
Connector Rd	POLYUREA THERMOPLASTIC	SNOWPLOWABLE
NC 116	POLYUREA	SNOWPLOWABLE
NC 107	POLYUREA	SNOWPLOWABLE

- B) TIE PROPOSED PAVEMENT MARKING LINES TO EXISTING PAVEMENT MARKING LINES.
- C) REMOVE/REPLACE ANY CONFLICTING/DAMAGED PAVEMENT MARKINGS AND MARKERS.
- D) PASSING ZONES WILL BE DETERMINED IN THE FIELD AND MUST BE APPROVED BY THE ENGINEER.
- E) STOP BAR LOCATION AT NON-SIGNALIZED INTERSECTIONS MAY BE ADJUSTED AS DIRECTED BY THE ENGINEER.
- F) REMOVE ALL RESIDUE AND SURFACE LAITANCE BY ACCEPTABLE METHODS ON THE CONCRETE SURFACES PRIOR TO PLACING (POLYUREA) PAVEMENT MARKING MATERIAL.
- G) ON ASPHALT SURFACES, USE HEATED-IN-PLACE THERMOPLASTIC OR EXTRUDED THERMOPLASTIC FOR STOP BARS, SYMBOLS, CHARACTERS AND DIAGONALS.
- H) MARKERS SHALL BE INSTALLED ACCORDING TO THE NCDOT ROADWAY STANDARD DRAWING 1250.01.

INDEX

SHEET NO.	DESCRIPTION
PMP-1	PAVEMENT MARKING PLAN TITLE
PMP-2	CROSSWALK AND STOP BAR PAVEMENT MARKING DETAIL
PMP-3	PAVEMENT MARKING SCHEDULES
PMP-4-9	PAVEMENT MARKING DETAIL

PLAN PREPARED BY: N.C.D.O.T. SIGNING AND DELINEATION UNIT

KELVIN JORDAN SIGNING & DELINEATION REGIONAL ENGINEER

J. NAVARRETE SIGNING & DELINEATION DESIGN ENGINEER

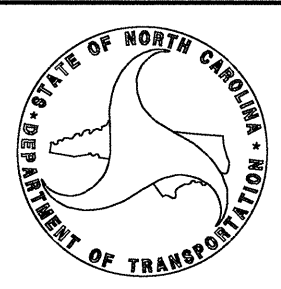

Q:\Projects\Projects\11-22-11 R5000 ROW Submitted to NCDOT & Carano\Proj\Signing\R-5000_Sgn_BPMP_sheets.dgn
 AT 11:24:03
 jnavarrete

CONTRACT:

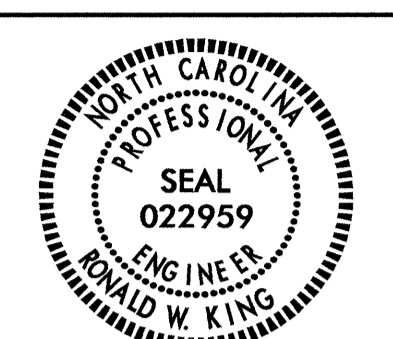
TIP NO. R-5000	SHEET NO. PMP-2
APPROVED: <i>[Signature]</i>	DATE: 7/3/12
SEAL	
	

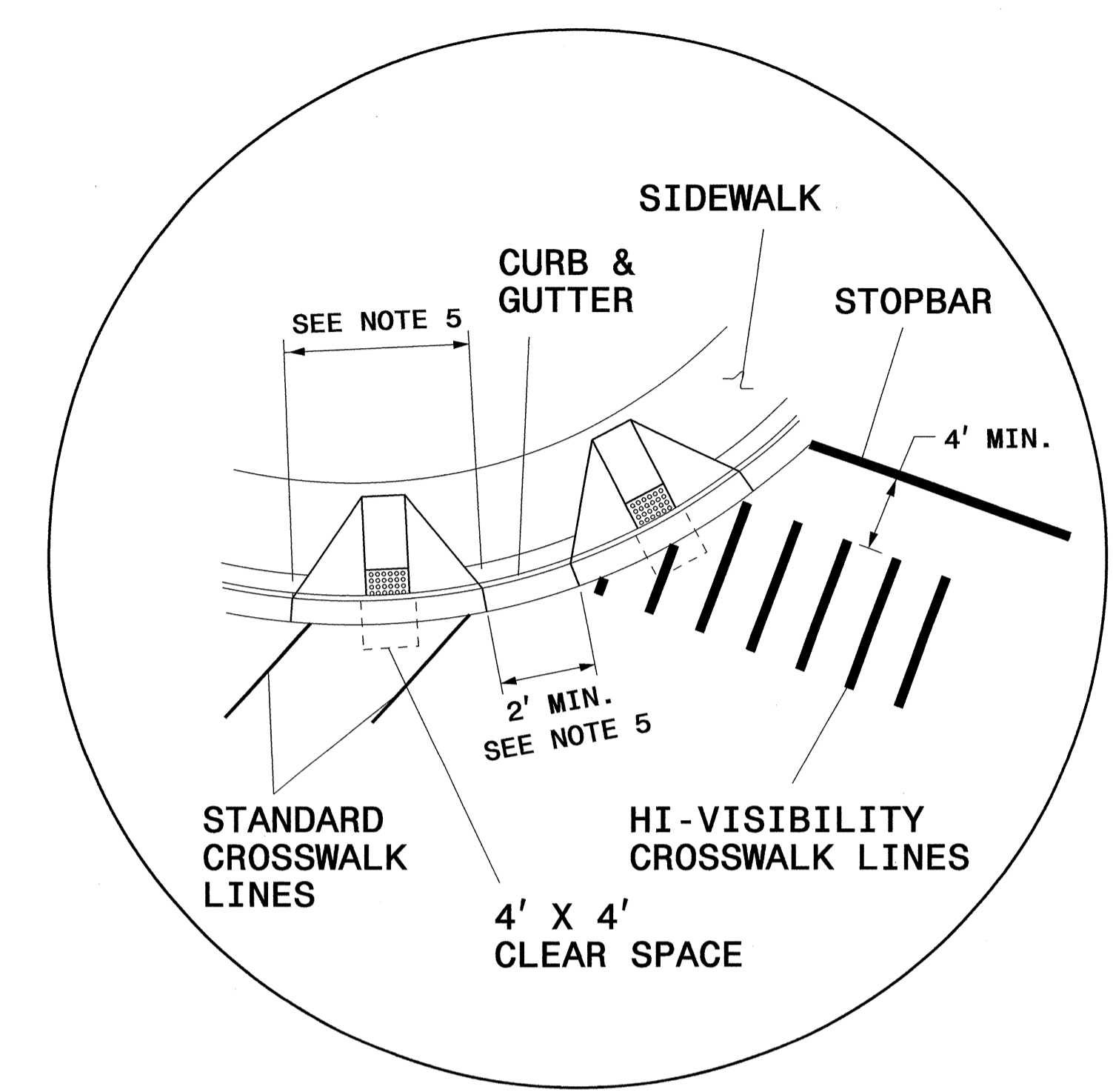
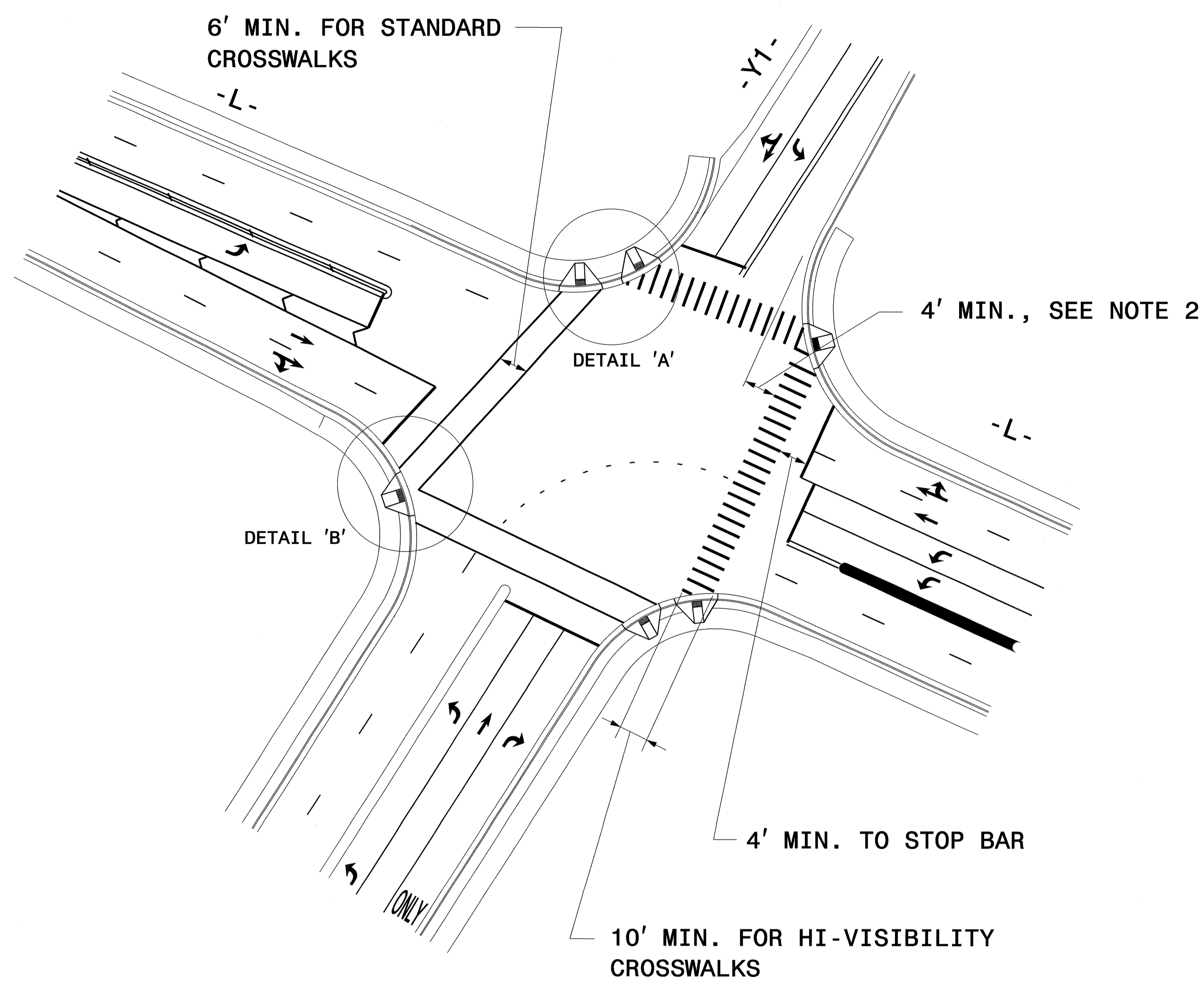

DETAIL 'A'- DUAL CURB RAMPS

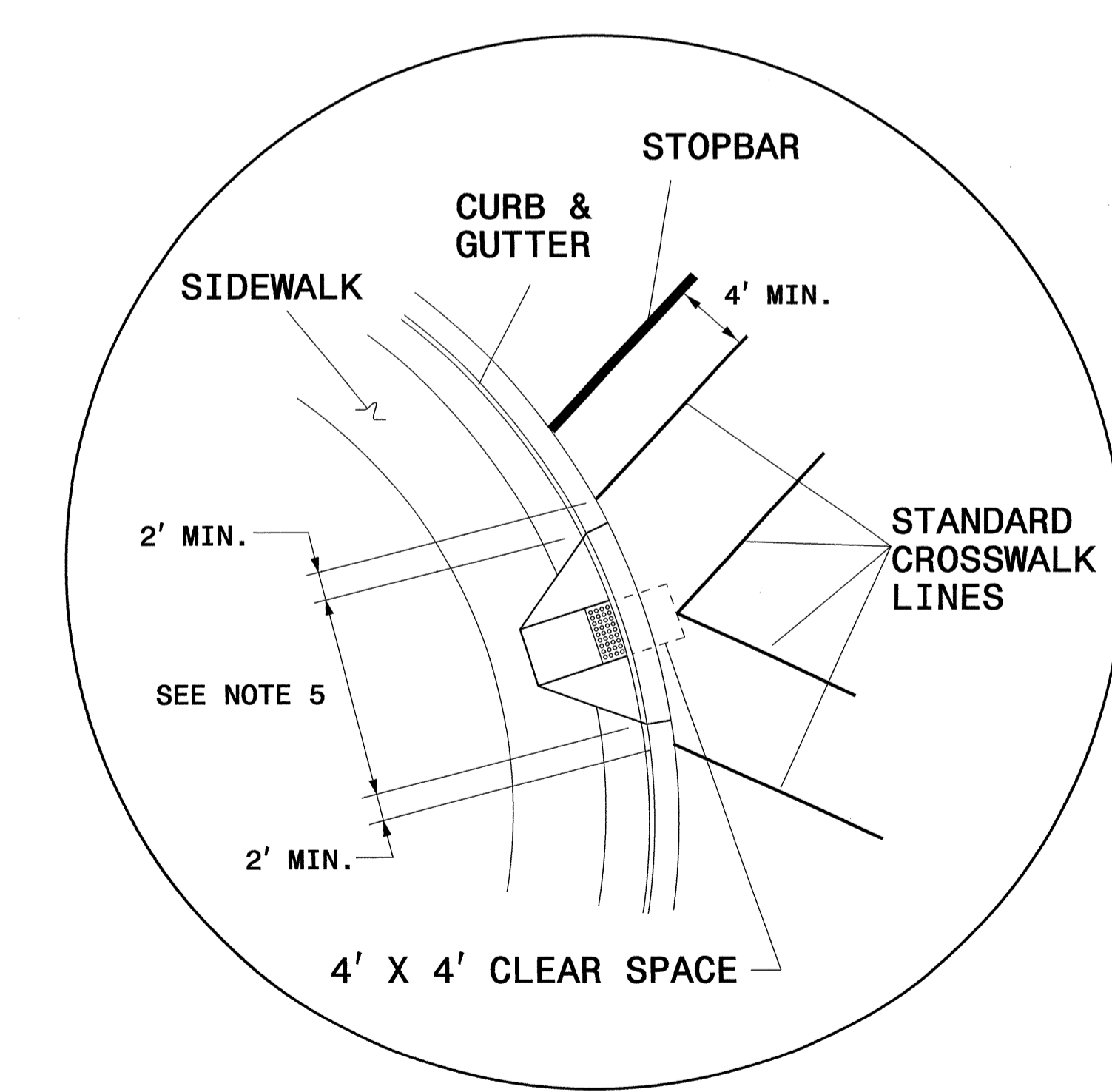

DETAIL 'B'- SINGLE DIAGONAL CURB RAMP

GUIDANCE DETAIL FOR STANDARD AND HI-VISIBILITY CROSSWALKS AT SIGNALIZED OR STOP SIGN CONTROLLED INTERSECTIONS

1. USE DETAILS ABOVE AND THE FOLLOWING NOTES FOR GUIDANCE IN PLACING CROSSWALKS AND STOP BARS NOT STATIONED ON THE DETAIL SHEETS OR WHEN FIELD ADJUSTMENTS REQUIRED MOVING STATIONED MARKINGS AS DIRECTED BY THE ENGINEER. REFER TO NCDOT ROADWAY STANDARD DRAWINGS, MUTCD AND ADA STANDARDS FOR ADDITIONAL GUIDANCE.
2. SET BACK DISTANCE FROM INSIDE CROSSWALK MARKING TO NEAREST EDGE OF TRAVEL IS 4' MIN.
3. BEYOND THE CURB FACE, A CLEAR SPACE OF 4' X 4' MINIMUM SHALL BE PROVIDED WITHIN THE WIDTH OF THE CROSSWALK.
4. SINGLE DIAGONAL CURB RAMPS WITH FLARED SIDES SHALL HAVE A SEGMENT OF CURB 2 FEET LONG MINIMUM LOCATED ON EACH SIDE OF THE CURB RAMP AND WITHIN THE MARKED CROSSING, SEE DETAIL 'B'.
5. CURB RAMPS SHALL BE CONSTRUCTED IN ACCORDANCE TO THE LATEST NCDOT ROADWAY STANDARD DRAWINGS.

CROSSWALK AND STOP BAR PAVEMENT MARKING DETAIL

03-JUL-2012 14:08
 S:\S&D\TIPPROJECTS\R-5000\11-22-11R5000 ROW Submittal To NCDOT & Cardinal\Proj\Signing\R-5000_Sgn_BPMP_sheets.dgn
 jmvvrrr
 AT 1246703

TIP NO. R-5000	SHEET NO. PMP-3
APPROVED: <i>RWF</i>	
DATE: 7/3/12	
SEAL	
	

Pavement Marking Schedule
TIP Project # R-5000

SYMBOL	DESCRIPTION	FINAL PAVEMENT MARKINGS
V10 VS	3 FT. - 3 FT./SP WHITE MINISKIP WHITE GORELINE	POLYUREA(12")
T2	WHITE STOPBAR	THERMOPLASTIC(24", 120 MILS)
V8 VA VB VE VF VH VI	2 FT. - 6 FT./SP WHITE MINISKIP WHITE EDGELINE YELLOW EDGELINE WHITE SOLID LANE LINE 10 FT. YELLOW SKIP YELLOW SINGLE CENTER YELLOW DOUBLE CENTER	POLYUREA(4")
VJ	10 FT. WHITE SKIP	POLYUREA(6")
V13	3 FT. - 9 FT./SP WHITE MINISKIP	POLYUREA(8")
TP	YELLOW DIAGONAL	THERMOPLASTIC(8", 90 MILS)
UA UB UF UN UJ UK UP	LEFT TURN ARROW RIGHT TURN ARROW COMBO.LEFT/RIGHT 24" YIELD LINE TRIANGLE BICYCLE SYMBOL BICYCLE ARROW SYMBOL MERGE ARROW SYMBOL	THERMOPLASTICPAVEMENT MARKING SYMBOLS (90 MILS)

Pavement Marking Schedule
TIP Project # R-5000

SYMBOL	DESCRIPTION	MARKERS
ME	YELLOW & YELLOW	SNOWPLOWABLE RAISED PAVEMENT MARKERS
MI	CRYSTAL & RED	TEMPORARY MARKERS TEMPORARY RAISED PAVEMENT MARKERS

PAVEMENT MARKING SCHEDULE

03-Jul-2012 09:55:09
 S:\SDUN\PROJECTS\R-5000\11-22-11 R5000 ROW Submittal to NCDOT & Cardno\Proj\Signting\R-5000_Sgn_BPMP_sheets.dgn
 Print Date: 7/3/12

TIP NO. R-5000	SHEET NO. PMP-5
APPROVED: <i>[Signature]</i>	
DATE: 7/3/12	
SEAL	

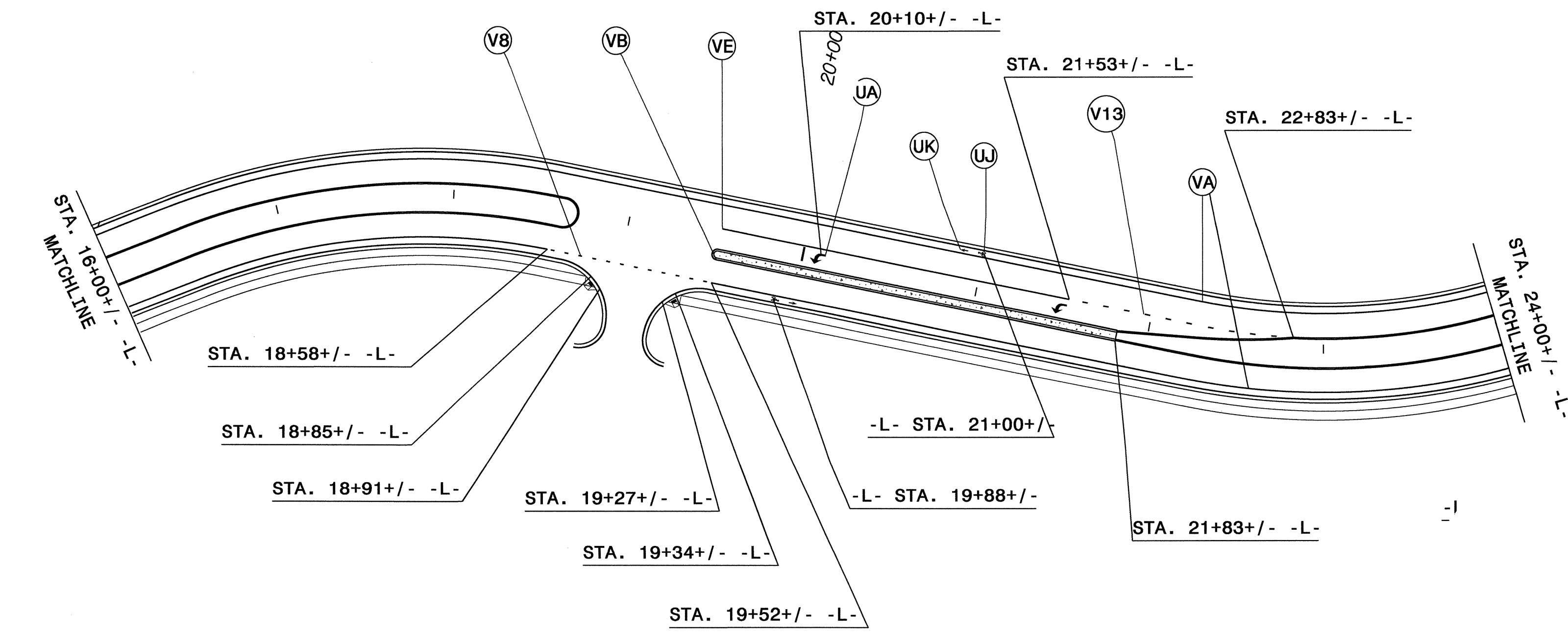
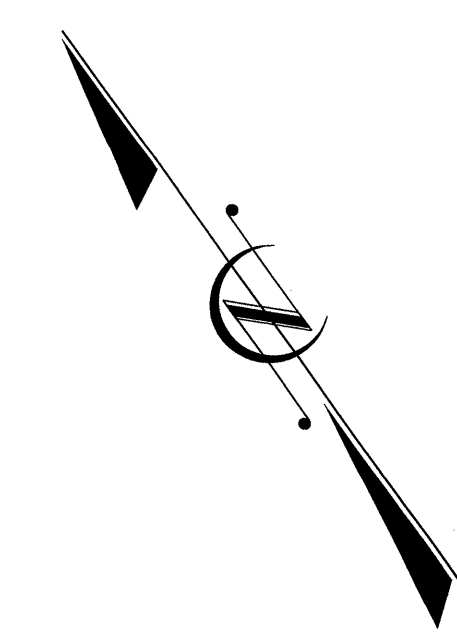

PAVEMENT MARKING SCHEDULE

SYMBOL	DESCRIPTION
VE	WHITE SOLID LANE LINE (4")
VA	WHITE EDGELINE (4")
VB	YELLOW EDGELINE (4")
V8	2 FT.-6FT./SP WHITE MINISKIP (4")
V13	3FT.-9FT./SP WHITE MINISKIP (8")
UA	LEFT TURN ARROW
UJ	BICYCLE SYMBOL
UK	BICYCLE ARROW SYMBOL

PAVEMENT MARKING DETAIL

03-JUL-2012 14:19
 S:\S&D\TIPPROJECTS\R-5000\12-11R5000 ROW Submittal to NCDOT & Cardmo\Proj\Signing\R-5000_Sgn_BPMP_sheets.dgn
 jnnavarrete AT 12246703

TIP NO.	SHEET NO.
R-5000	PMP-6
APPROVED:	<i>[Signature]</i>
DATE:	7/3/12
SEAL	

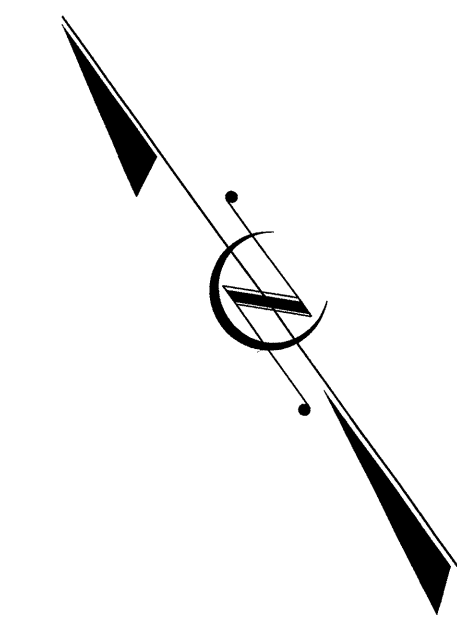
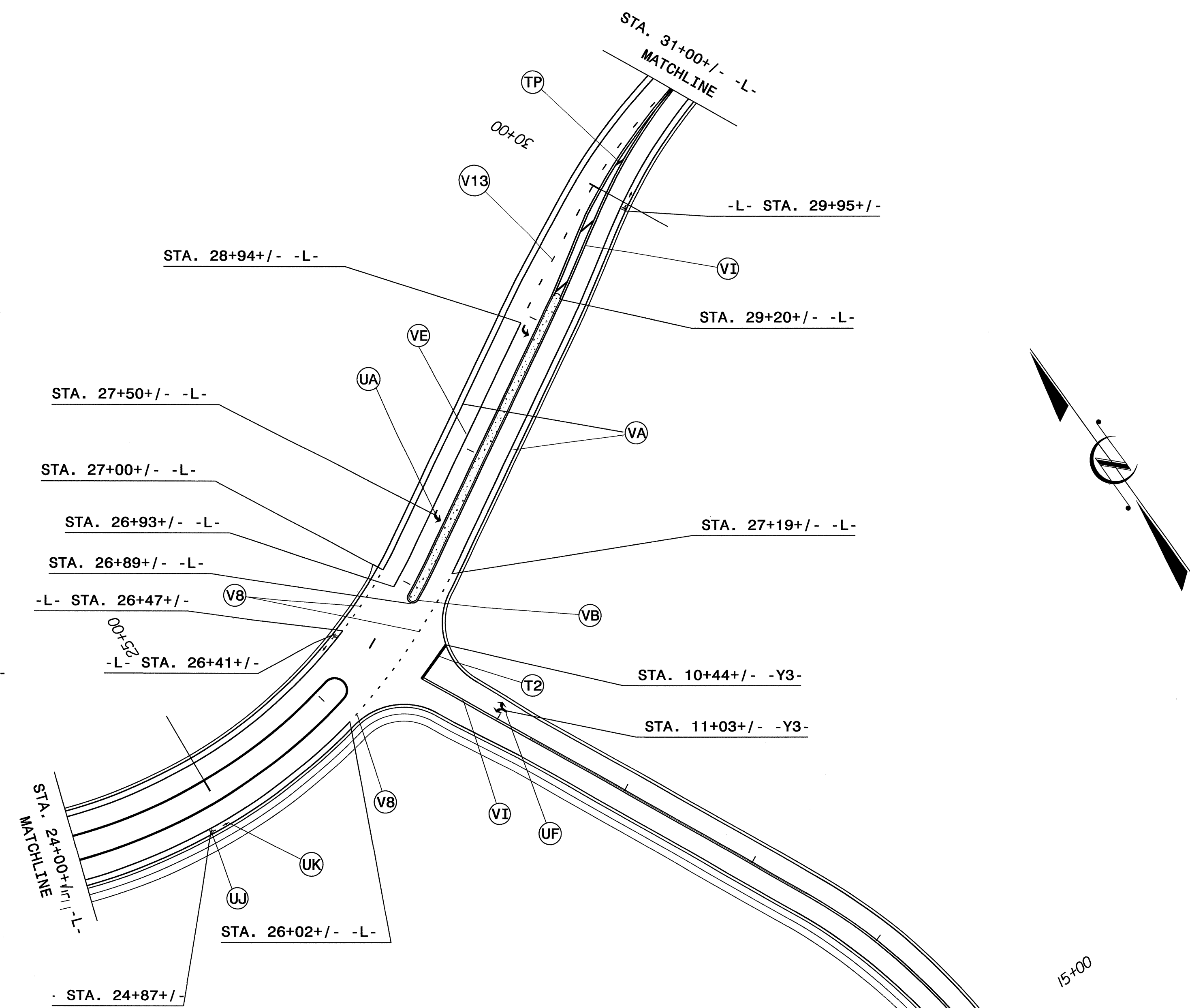

PAVEMENT MARKING SCHEDULE

SYMBOL	DESCRIPTION
T2	WHITE STOP BAR (24")
VB	YELLOW EDGELINE (4")
VE	WHITE SOLID LANE LINE (4")
VA	WHITE EDGELINE (4")
VI	YELLOW DOUBLE CENTER (4")
V8	2 FT.-6FT./SP WHITE MINISKIP (4")
V13	3FT.-9FT./SP WHITE MINISKIP (8")
UF	COMBO.LEFT/RIGHT
UA	LEFT TURN ARROW
UJ	BICYCLE SYMBOL
UK	BICYCLE ARROW SYMBOL

PAVEMENT MARKING DETAIL

03-JUL-2012 14:19
 S:\8&D\PROJECTS\R-5000\11-22-11R5000 ROW Submittal to NCDOT & Cardno\Proj\Signing\R-5000_Sgn_BPMP_sheets.dgn
 jmvavrrr.etc AT 12246703

TIP NO. R-5000	SHEET NO. PMP-7
APPROVED: <i>[Signature]</i>	
DATE: 7/7/12	
SEAL	

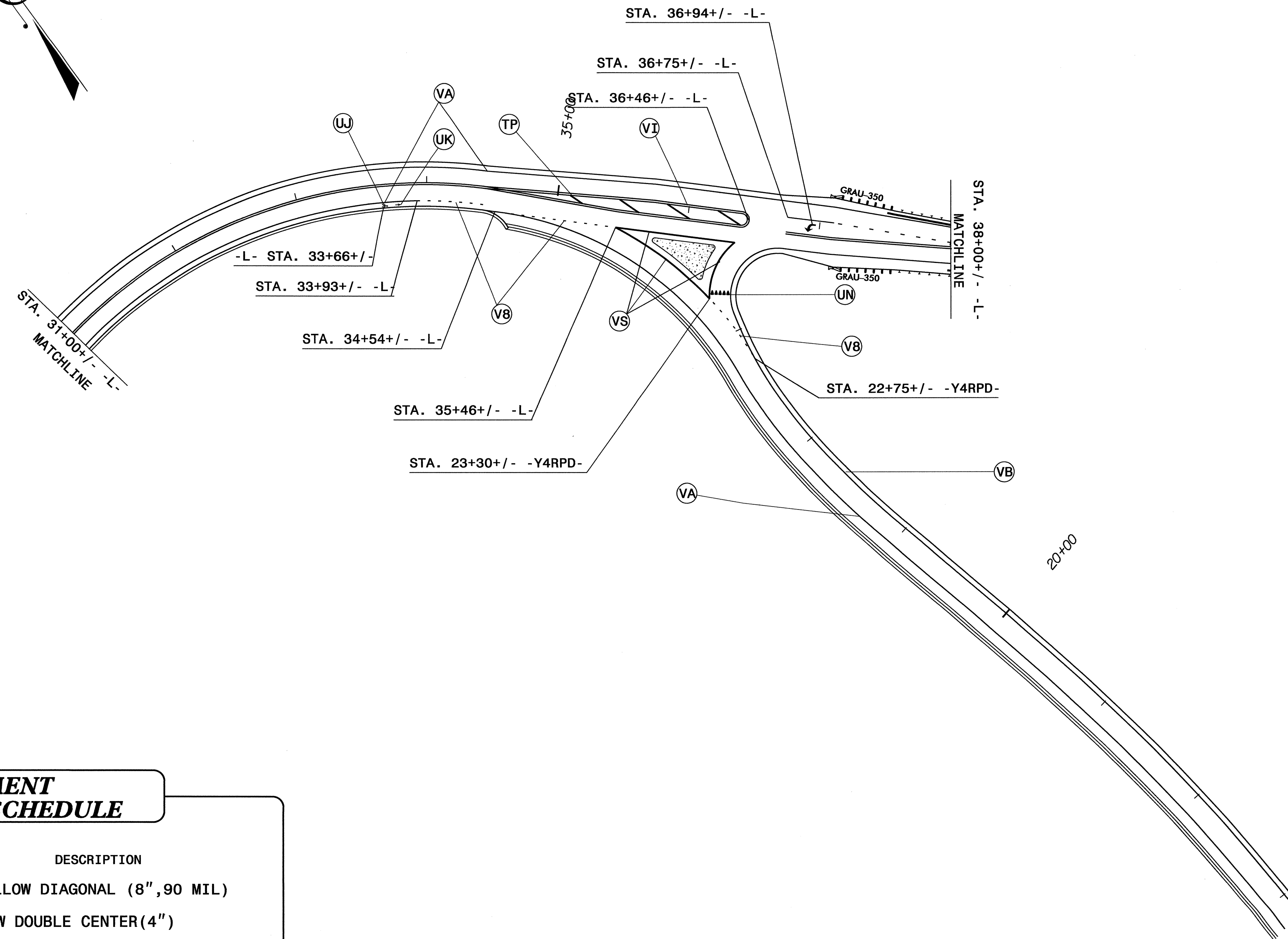
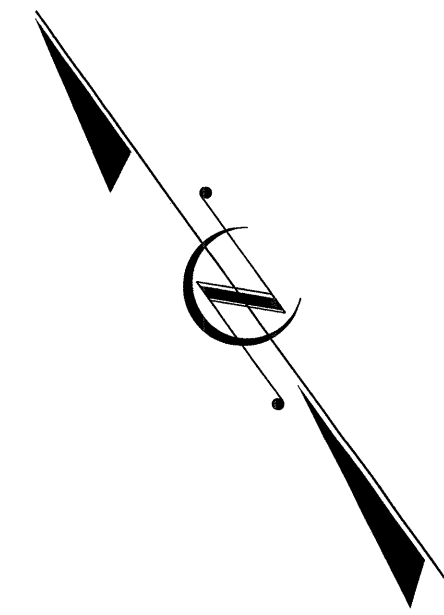



PAVEMENT MARKING SCHEDULE

SYMBOL	DESCRIPTION
TP	YELLOW DIAGONAL (8", 90 MIL)
VI	YELLOW DOUBLE CENTER (4")
VA	WHITE EDGELINE (4")
VB	YELLOW EDGELINE (4")
V8	2 FT. -6FT/SP WHITE MINISKIP (4")
UN	▲ 24" YIELD LINE TRIANGLE
UJ	↻ BICYCLE SYMBOL
UK	→ BICYCLE ARROW SYMBOL

PAVEMENT MARKING DETAIL

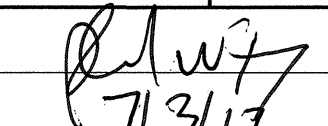
03-JUL-2012 14:20
 S:\S&D\TIP\PROJECTS\R-5000\11-22-11R5000 ROW Submittal to NCDOT & Cardmo\Proj\Signing\R-5000_Sgn_BPMP_sheets.dgn
 jmsvrr87e AT 12:46:03

TIP NO.	SHEET NO.
R-5000	PMP-8
APPROVED:	
DATE:	7/3/12
SEAL	

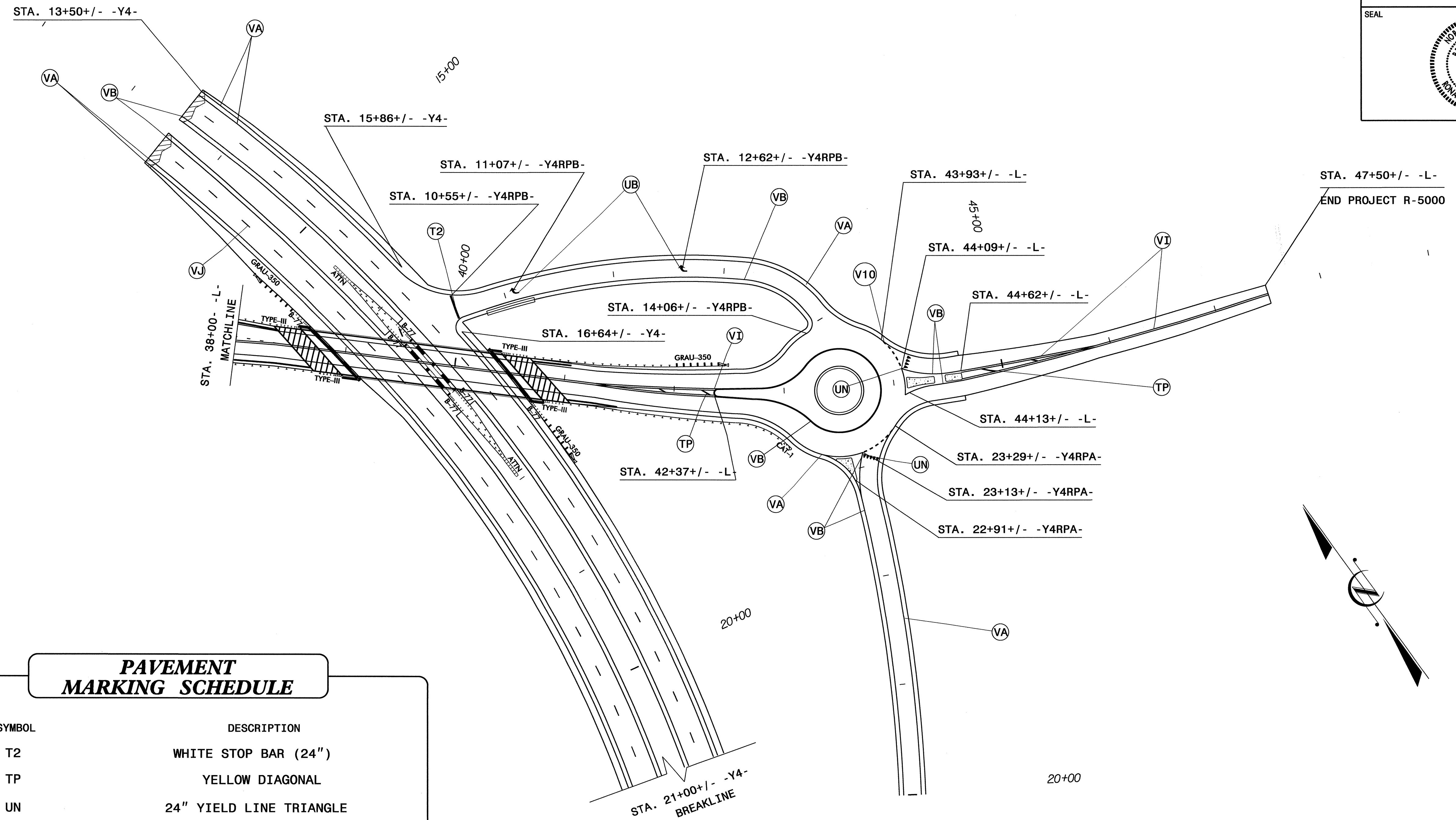

PAVEMENT MARKING SCHEDULE

SYMBOL	DESCRIPTION
T2	WHITE STOP BAR (24")
TP	YELLOW DIAGONAL
UN	24" YIELD LINE TRIANGLE
VA	WHITE EDGELINE (4")
VB	YELLOW EDGELINE (4")
VI	YELLOW DOUBLE CENTER (4")
VJ	10 FT. WHITE SKIP(6")
V10	3FT.-3FT./SP WHITE MINISKIP (12")

UB  RIGHT TURN ARROW



PAVEMENT MARKING DETAIL

03-JUL-2012 15:45 S:\S&D\TIPPROJECTS\R-5000\11-22-11R5000 ROW Submittal\To NCDOT & Cardano\Proj\Signing\R-5000_Sgn_BPMP_sheets.dgn Innavarrete AT 1E246703

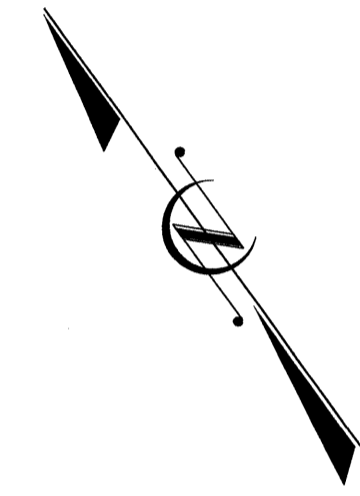
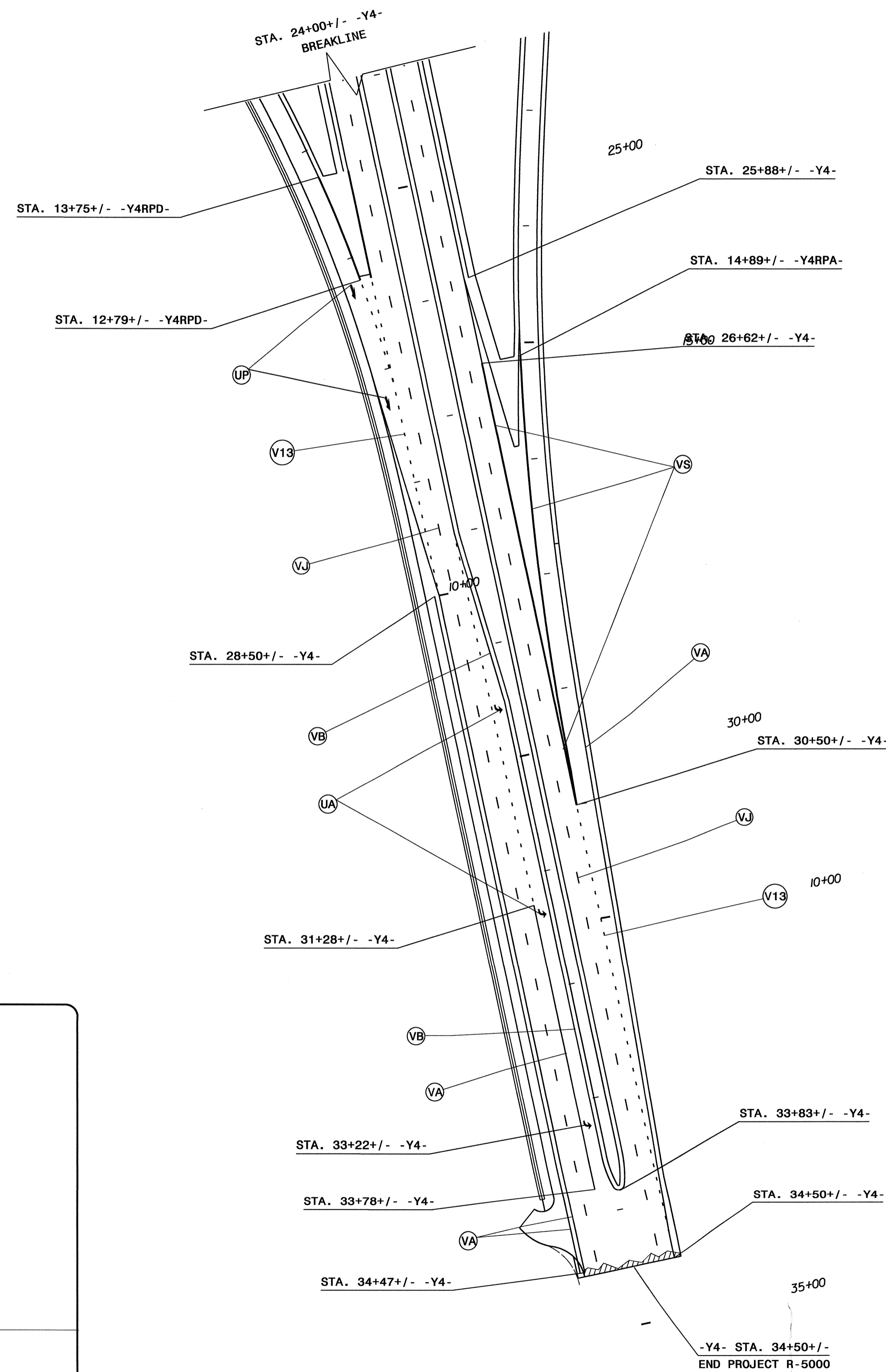
TIP NO.	SHEET NO.
R-5000	PMP-9
APPROVED: <i>[Signature]</i>	
DATE: 7/3/12	
SEAL	
	



PAVEMENT MARKING SCHEDULE

SYMBOL	DESCRIPTION
T2	WHITE STOP BAR (24")
VA	WHITE EDGELINE (4")
VB	YELLOW EDGELINE (4")
VJ	10 FT. WHITE SKIP (6")
VS	WHITE GORELINE (12")
V8	2 FT. -6FT./SP WHITE MINISKIP (4")
V13	3FT. -9FT./SP WHITE MINISKIP (8")
UA	 LEFT TURN ARROW
UP	 MERGE ARROW

PAVEMENT MARKING DETAIL

03-JUL-2012 15:46
 S:\S&D\TIP\PROJECTS\R-5000\12-22-11R5000 ROW Submittal to NCDOT & Cardno\Proj\Signing\R-5000_Sgn_BPMP_sheets.dgn
 jnnavarrete AT 12/24/10