

STATE OF NORTH CAROLINA  
DEPARTMENT OF TRANSPORTATION

TIP NO. X-0002BB	SHEET NO. PMP-1
APPROVED: <i>[Signature]</i>	
DATE: 8-14-12	
SEAL	

PAVEMENT MARKING PLAN  
CUMBERLAND COUNTY

T.I.P.: X-0002BB

CONTRACT: C202948

**INDEX**

SHEET NO.	DESCRIPTION
PMP-1	PAVEMENT MARKING PLAN COVER SHEET
PMP-2	PAVEMENT MARKING SCHEDULE
PMP-3-17	PAVEMENT MARKING DETAIL

**ROADWAY STANDARD DRAWING**

THE FOLLOWING ROADWAY STANDARDS AS APPEAR IN "ROADWAY STANDARD DRAWINGS" - PROJECT SERVICES UNIT - N.C. DEPARTMENT OF TRANSPORTATION - RALEIGH, N.C., DATED JULY 2006 ARE APPLICABLE TO THIS PROJECT AND BY REFERENCE HEREBY ARE CONSIDERED A PART OF THESE PLANS:

STD. NO.	TITLE
1205.01	PAVEMENT MARKINGS - LINE TYPES AND OFFSETS
1205.02	PAVEMENT MARKINGS - TWO-LANE AND MULTILANE ROADWAYS
1205.03	PAVEMENT MARKINGS - EXIT AND ENTRANCE RAMPS
1205.04	PAVEMENT MARKINGS - INTERSECTIONS
1205.05	PAVEMENT MARKINGS - TURN LANES
1205.06	PAVEMENT MARKINGS - LANE DROPS
1205.08	PAVEMENT MARKINGS - SYMBOLS AND WORD MESSAGES
1205.09	PAVEMENT MARKINGS - PAINTED ISLANDS
1205.12	PAVEMENT MARKINGS - BRIDGES
1205.13	PAVEMENT MARKINGS - LANE REDUCTIONS
1250.01	RAISED PAVEMENT MARKERS - INSTALLATION SPACING
1251.01	RAISED PAVEMENT MARKERS - PERMANENT AND TEMPORARY
1261.01	GUARDRAIL AND BARRIER DELINEATORS - INSTALLATION SPACING
1261.02	GUARDRAIL AND BARRIER DELINEATORS - TYPES AND MOUNTING
1262.01	GUARDRAIL END DELINEATION

**GENERAL NOTES**

THE FOLLOWING GENERAL NOTES APPLY AT ALL TIMES FOR THE DURATION OF THE CONSTRUCTION PROJECT, EXCEPT WHEN OTHERWISE NOTED IN THE PLAN, OR DIRECTED BY THE ENGINEER.

- A) INSTALL PAVEMENT MARKINGS AND PAVEMENT MARKERS ON THE FINAL SURFACE AS FOLLOWS:

ROAD NAME	MARKING	MARKER
ALL	THERMOPLASTIC	PERMANENT RAISED
-L-, -COL2-, -RPCDR-, -FLY-	POLYUREA (USE WITH CONCRETE ALTERNATE, SEE ROADWAY PLANS FOR STATIONS)	

- B) TYPE III COLD APPLIED PLASTIC MAY BE USED IN LIEU OF TYPE II COLD APPLIED PLASTIC. IF TYPE III COLD APPLIED PLASTIC IS USED, IT SHALL BE PAID FOR USING THE TYPE II COLD APPLIED PLASTIC PAY ITEM.
- C) TIE PROPOSED PAVEMENT MARKING LINES TO EXISTING PAVEMENT MARKING LINES.
- D) REMOVE/REPLACE ANY CONFLICTING/DAMAGED PAVEMENT MARKINGS AND MARKERS.
- E) STOP BAR LOCATION AT NON-SIGNALIZED INTERSECTIONS MAY BE ADJUSTED AS DIRECTED BY THE ENGINEER.
- F) ON ASPHALT SURFACES, USE HEATED-IN-PLACE THERMOPLASTIC OR EXTRUDED THERMOPLASTIC FOR STOP BARS, SYMBOLS, CHARACTERS AND DIAGONALS.
- G) ON CONCRETE SURFACES, USE HEATED-IN-PLACE THERMOPLASTIC OR COLD APPLIED PLASTIC FOR STOP BARS, SYMBOLS, CHARACTERS AND DIAGONALS.
- H) MARKERS SHALL BE INSTALLED ACCORDING TO THE NCDOT ROADWAY STANDARD DRAWING 1250.01.

PLAN REVIEWED BY: N.C.D.O.T. SIGNING AND DELINEATION UNIT

AYMAN ALQUDWAH, PE SIGNING & DELINEATION STANDARDS ENGINEER  
MITCH EATON SIGNING & DELINEATION PROJECT DESIGN ENGINEER

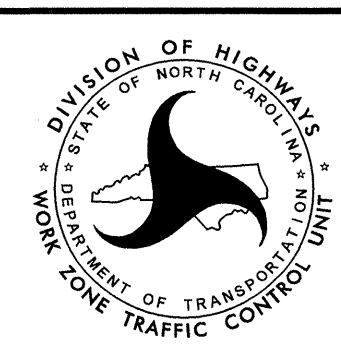

PLAN PREPARED BY: firms name here

TYSON GRAVES, PE PROJECT ENGINEER  
GARY PARKER DESIGN ENGINEER

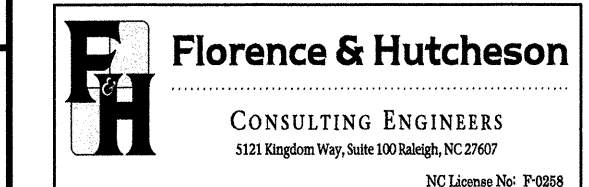



TIP NO. X-0002BB	SHEET NO. PMP-2
APPROVED: <i>[Signature]</i>	
DATE: 8-14-12	
SEAL	
	

# FINAL PAVEMENT MARKING SCHEDULE

SYMB	DESCRIPTION
	* THERMOPLASTIC(100MM, 2.3MM)
* TA	WHITE EDGELINE
* TB	YELLOW EDGELINE
	* THERMOPLASTIC(100MM, 3.1MM)
* T8	0.6 M - 1.8 M/SP WHITE MINISKIP
* TC	3 M WHITE SKIP
TD	0.9 M - 2.75 M/SP WHITE MINISKIP
TE	WHITE SOLID LANE LINE
	THERMOPLASTIC(200MM, 2.3MM)
TN	WHITE GORELINE
	THERMOPLASTIC(600MM, 3.1MM)
T2	WHITE STOPBAR
	THERMOPLASTIC PAVEMENT MARKING SYMBOLS (2.3MM)
UA	LEFT TURN ARROW
UB	RIGHT TURN ARROW
UP	MERGE ARROW
	MARKERS
	PERMANENT RAISED PAVEMENT MARKERS
MB	CRYSTAL & RED

\* FOR CONCRETE ALTERNATE, USE POLYUREA MARKINGS ON CONCRETE PAVEMENT.  
SEE ROADWAY PLANS FOR STATIONS.



**PAVEMENT MARKING SCHEDULE**

8/14/2012 P:\Signing & Delineation\X-0002BB\X-0002BB\_pm\_schedule.dgn Florence & Hutcheson



TIP NO. X-0002BB	SHEET NO. PMP-3
APPROVED: <i>[Signature]</i>	
DATE: 6-8-12	
SEAL	

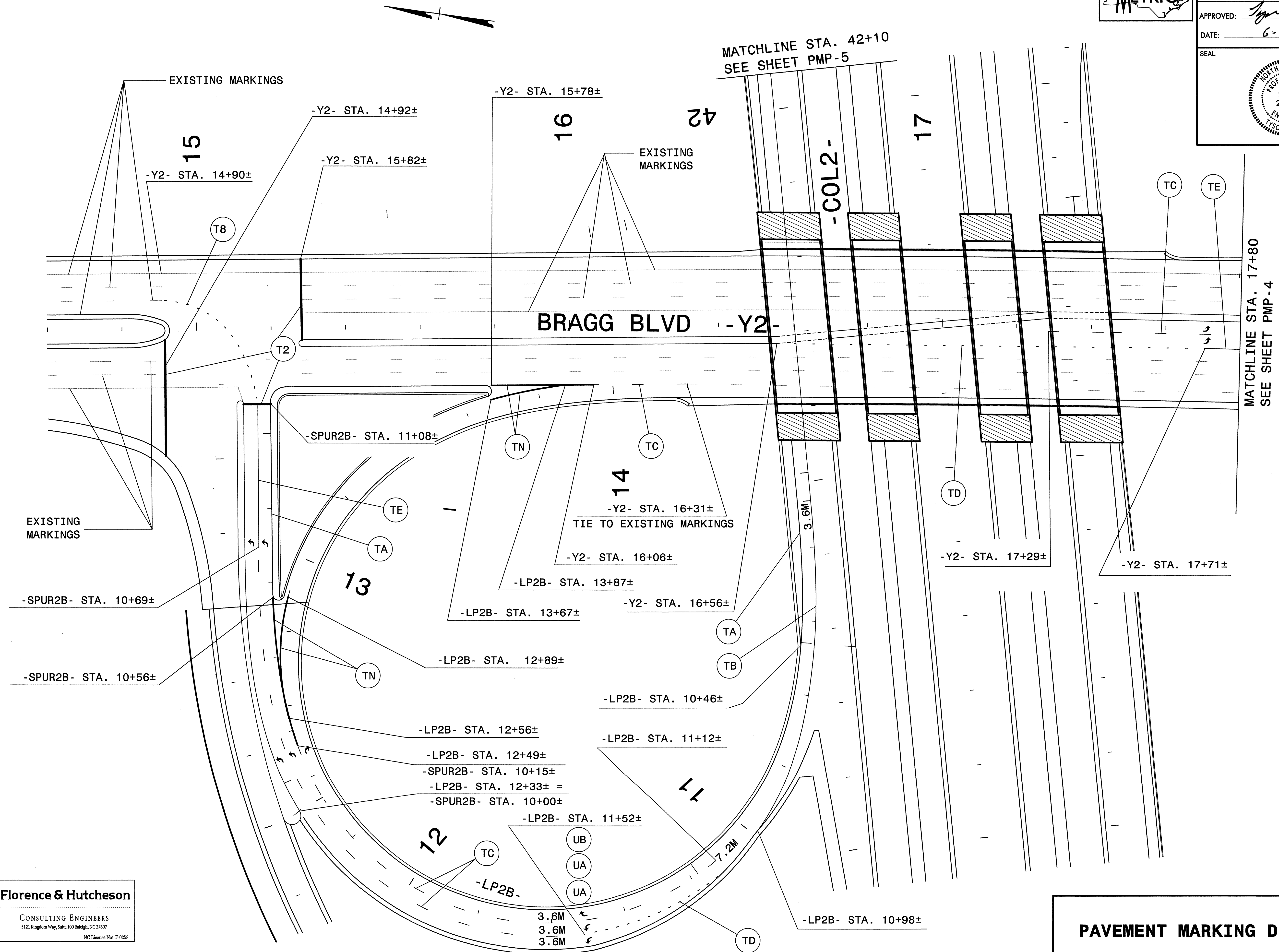

**FH** Florence & Hutcheson  
 CONSULTING ENGINEERS  
 5121 Kingdom Way, Suite 100 Raleigh, NC 27607  
 NC License No: P-0258

**PAVEMENT MARKING DETAIL**

6/7/2012 F:\Signing & Delinaction\X-0002BB\X-0002bb-pm\_dtl2.dgn Florence & Hutcheson



TIP NO. X-0002BB	SHEET NO. PMP-4
APPROVED: <i>[Signature]</i>	
DATE: 6-8-12	
SEAL	

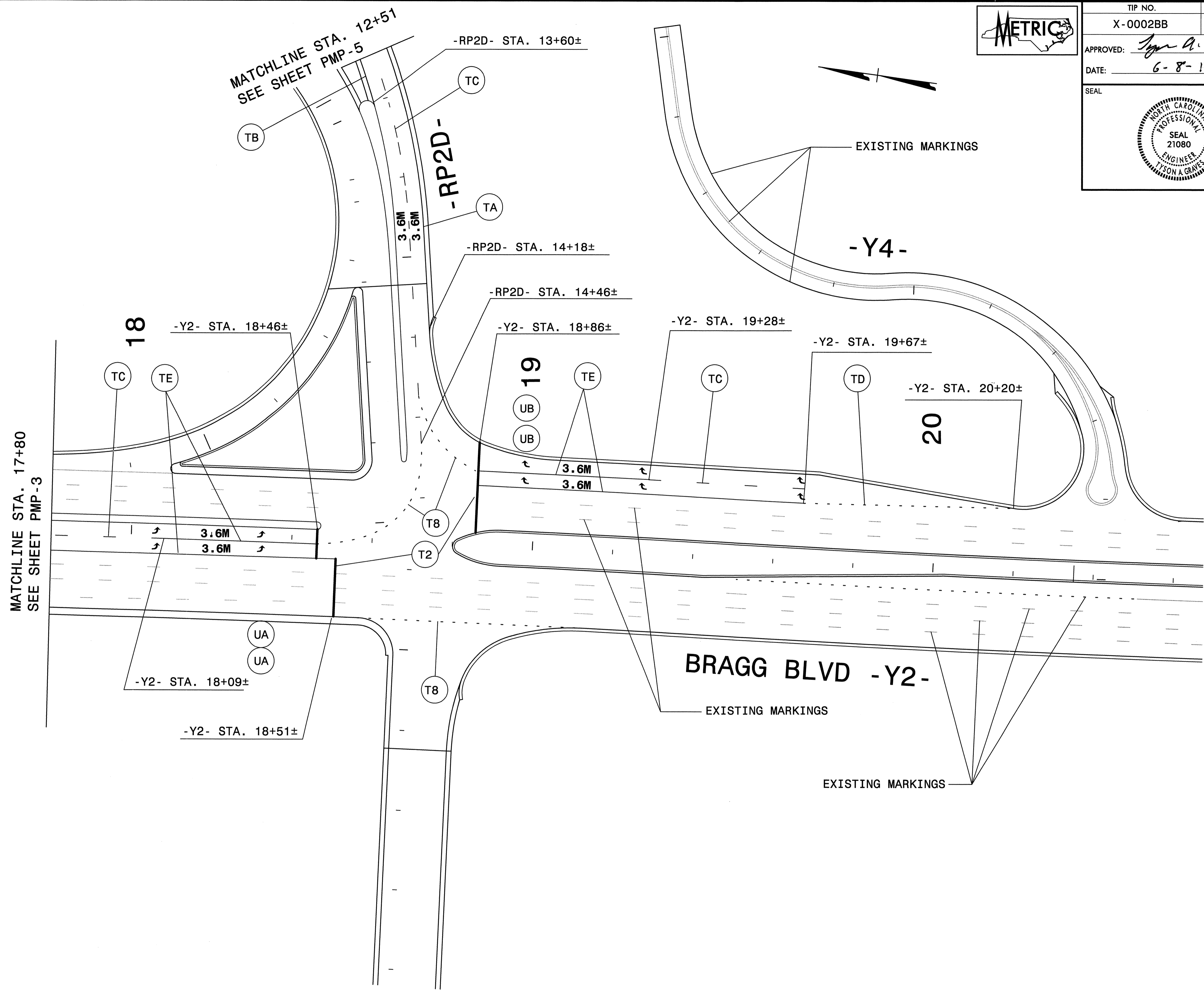

6/7/2012  
 P:\Signing & Delinecton\X-0002BB\X-0002bb\_pm\_d113.dgn  
 Florence & Hutcheson

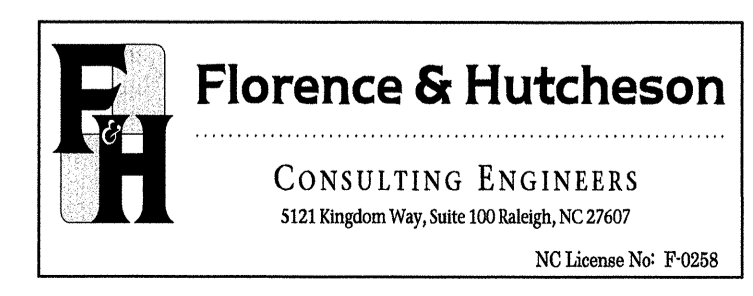

**PAVEMENT MARKING DETAIL**





TIP NO. X-0002BB	SHEET NO. PMP-5
APPROVED: <i>[Signature]</i>	
DATE: 6-8-12	
SEAL	

-L- STA. 44+04.273 (LB) =  
 -L- STA. 44+76.935 (LA) =  
 -COL2- STA. 44+04.274 (35.300m LT)

-COL2- STA 45+00±

MATCHLINE STA. 42+10  
SEE SHEET PMP-3

MATCHLINE STA. 46+00  
SEE SHEET PMP-6

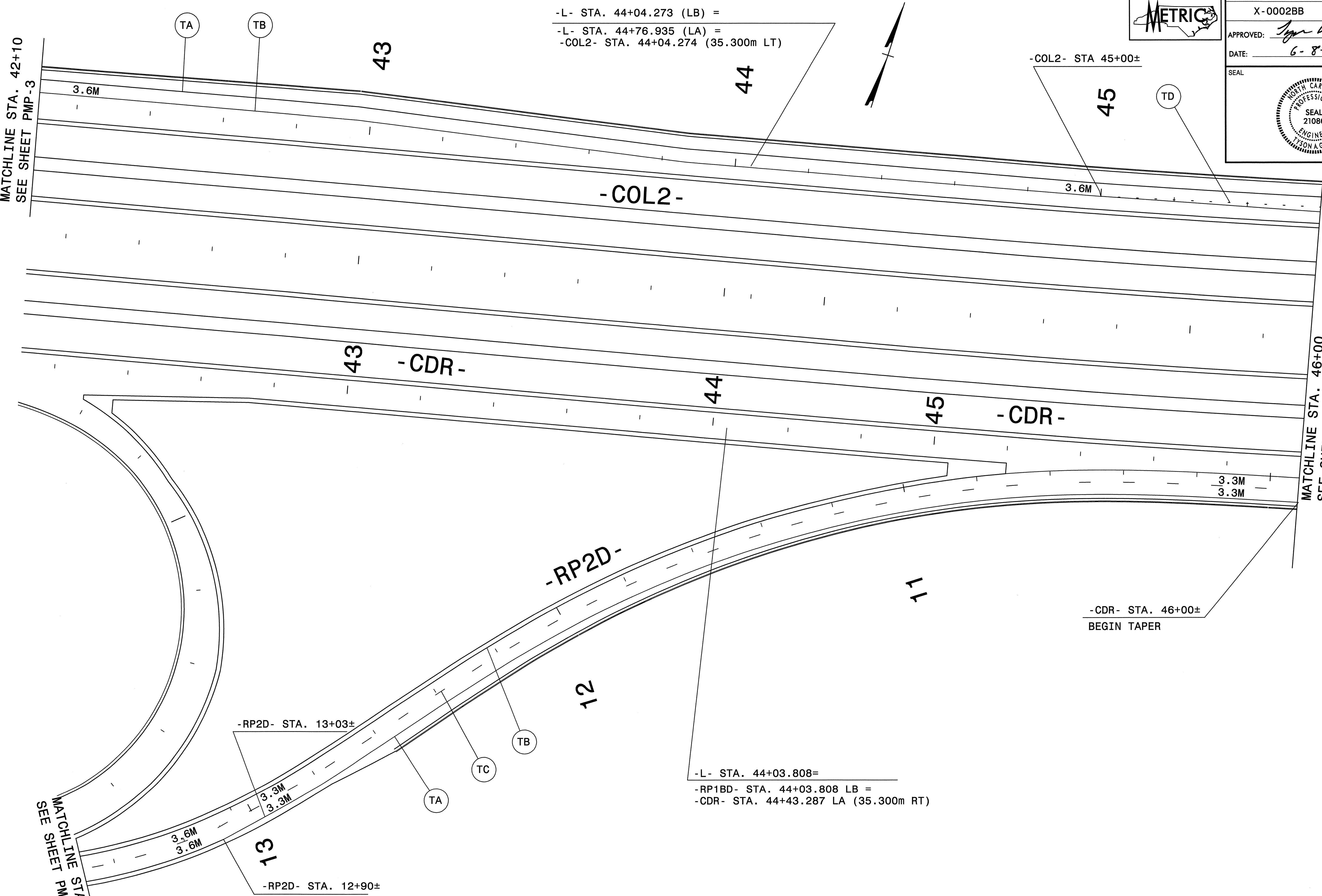

TA

TB

43

44

45

TD

-COL2-

43

-CDR-

44

45

-CDR-

-RP2D-

11

-CDR- STA. 46+00±  
BEGIN TAPER

12

-RP2D- STA. 13+03±

-L- STA. 44+03.808=  
 -RP1BD- STA. 44+03.808 LB =  
 -CDR- STA. 44+43.287 LA (35.300m RT)

MATCHLINE STA. 12+51  
SEE SHEET PMP-4

13

-RP2D- STA. 12+90±

**FH** Florence & Hutcheson  
 CONSULTING ENGINEERS  
 5121 Kingdom Way, Suite 100 Raleigh, NC 27607  
 NC License No. F-0058

**PAVEMENT MARKING DETAIL**

6/7/2012  
 F:\Signing & Delin\action\X-0002BB\X-0002bb-pm-dt14.dgn  
 Florence & Hutcheson



TIP NO. X-0002BB	SHEET NO. PMP-6
APPROVED: <i>[Signature]</i>	
DATE: 6-8-12	
SEAL	

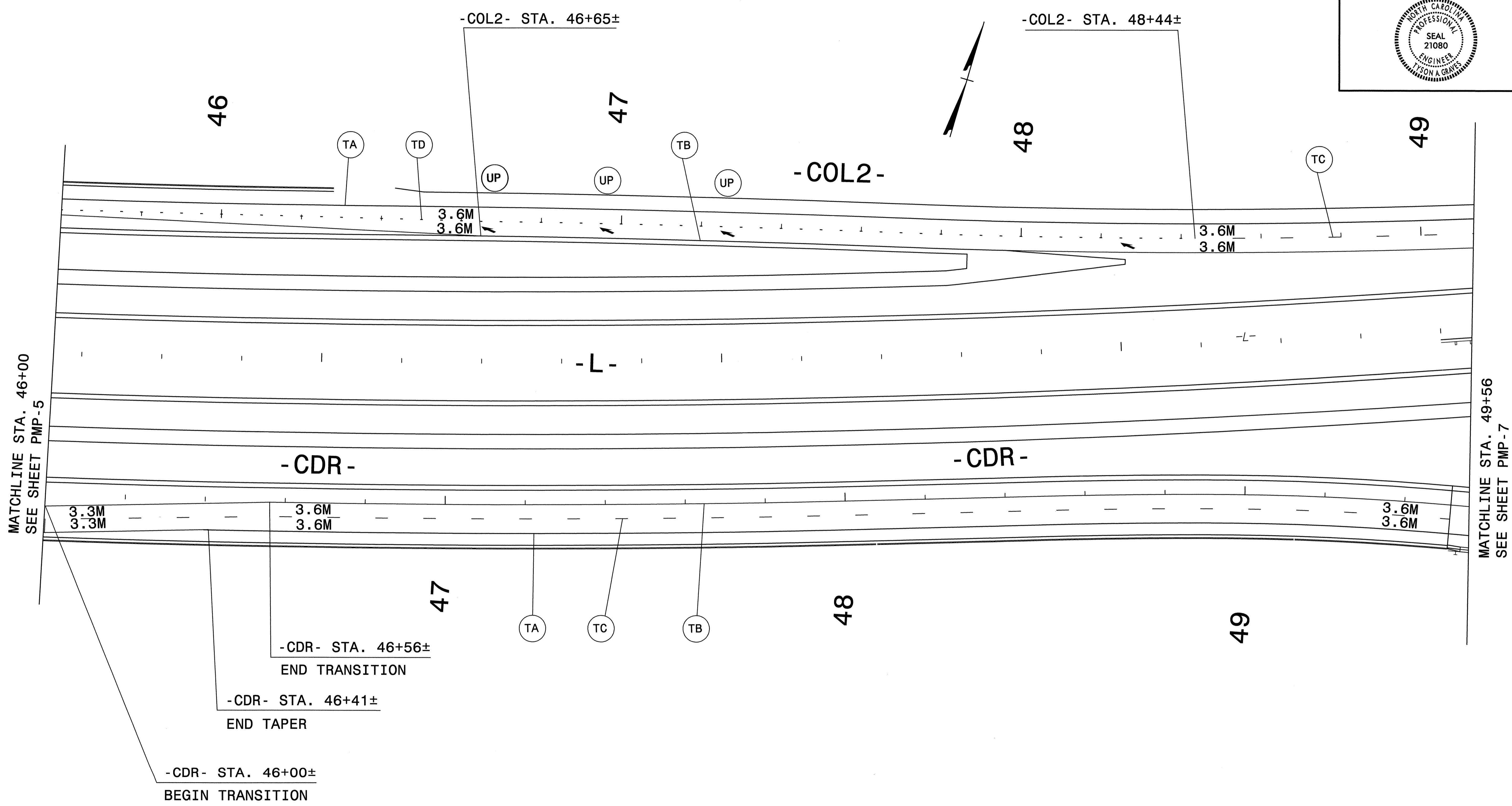

6/7/2012  
 P:\Signing & Delineation\X-0002BB\X0002bb\_pm\_d115.dgn  
 Florence & Hutcheson

**Florence & Hutcheson**  
 CONSULTING ENGINEERS  
 5121 Kingdom Way, Suite 100 Raleigh, NC 27607  
 NC License No: F-0288

**PAVEMENT MARKING DETAIL**



TIP NO. X-0002BB	SHEET NO. PMP-7
APPROVED: <i>Jason A. Graves</i>	
DATE: 6-8-12	
SEAL	

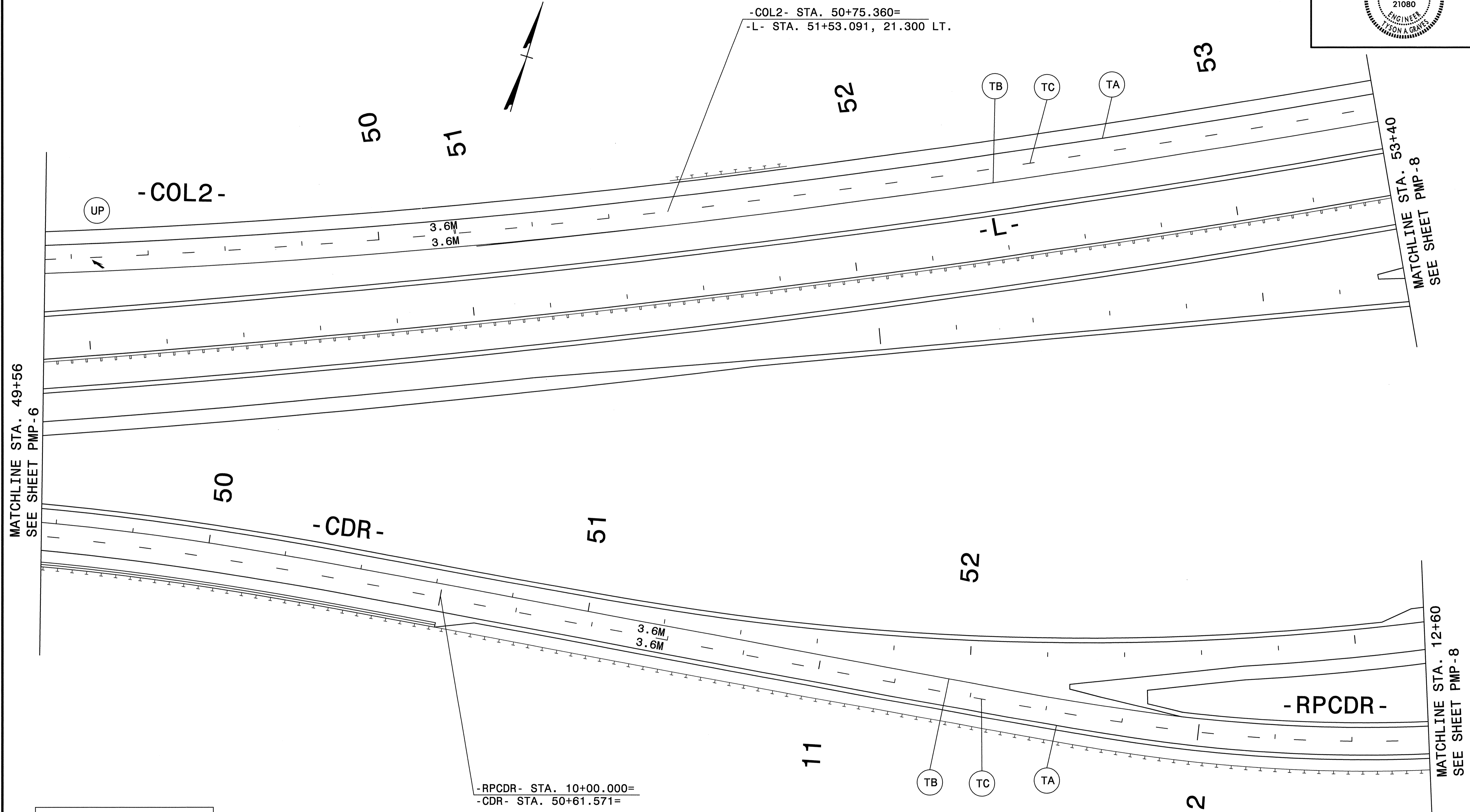

-COL2- STA. 50+75.360=  
 -L- STA. 51+53.091, 21.300 LT.

-RPCDR- STA. 10+00.000=  
 -CDR- STA. 50+61.571=

MATCHLINE STA. 49+56  
 SEE SHEET PMP-6

MATCHLINE STA. 53+40  
 SEE SHEET PMP-8

MATCHLINE STA. 12+60  
 SEE SHEET PMP-8



**PAVEMENT MARKING DETAIL**

6/7/2012  
 F:\Signing & Delineation\X-0002BB\X-0002bb-pm-dt16.dgn  
 Florence & Hutcheson

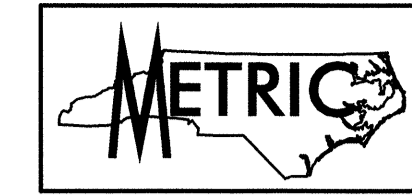

TIP NO. X-0002BB	SHEET NO. PMP-8
APPROVED: <i>[Signature]</i>	
DATE: 6-8-12	
SEAL	

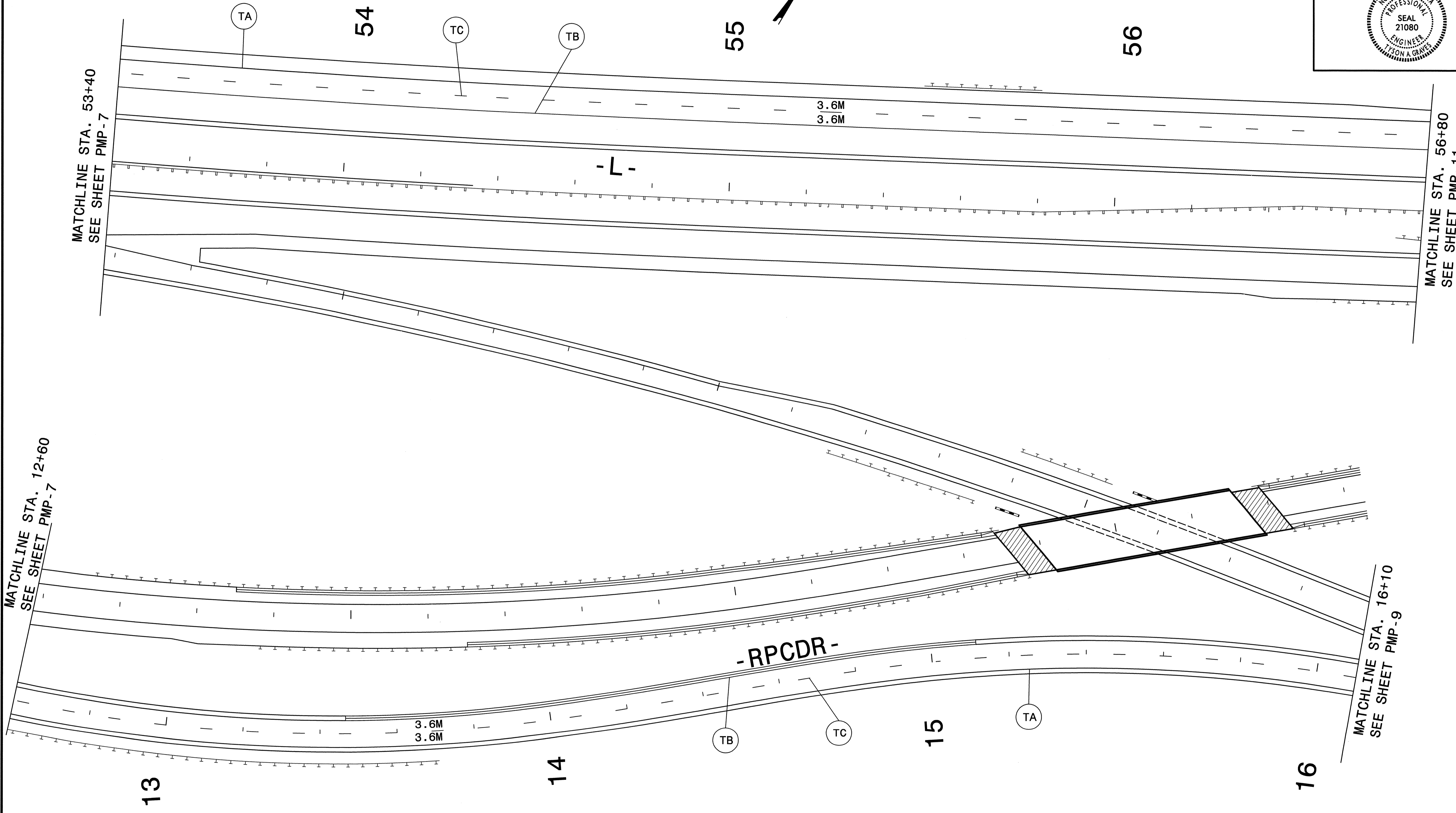

6/7/2012  
 P:\Signing & Delinerection\X-0002BB\X0002bb\_pm\_dtt7.dgn  
 Florence & Hutcheson



**PAVEMENT MARKING DETAIL**



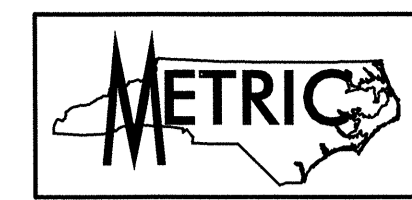

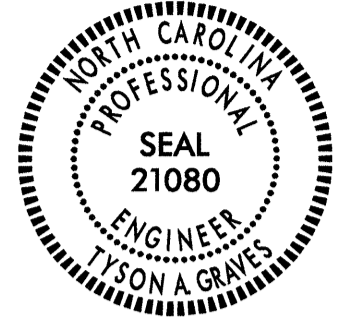
TIP NO. X-0002BB	SHEET NO. PMP-9
APPROVED: <i>[Signature]</i>	
DATE: 6-8-12	
SEAL	
	

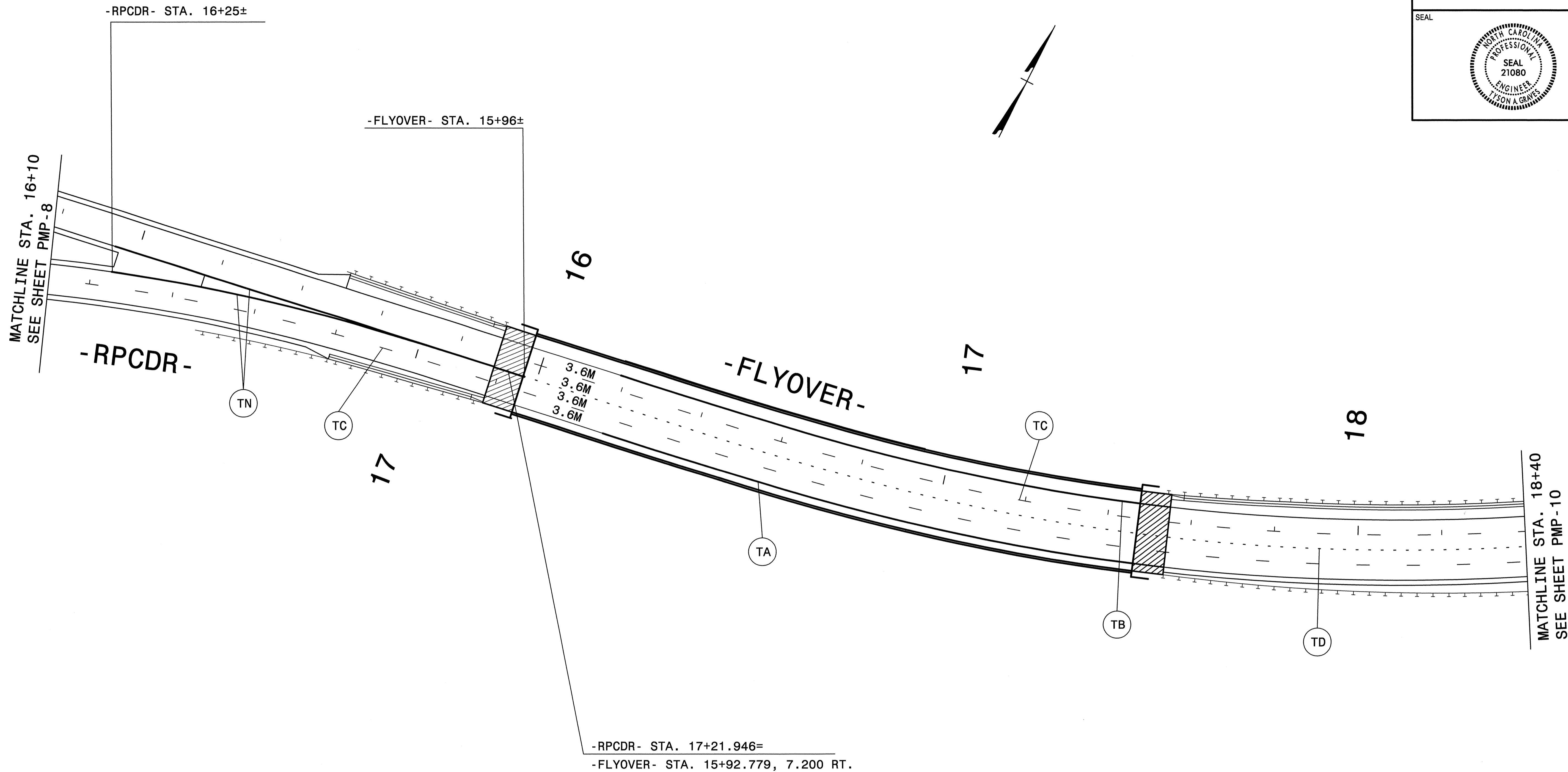

6/7/2012  
F:\Signing & Delinication\X-0002BB\X-0002bb-pm-dt18.dgn  
Florence & Hutcheson

**FH** Florence & Hutcheson  
CONSULTING ENGINEERS  
5121 Kingdom Way, Suite 100 Raleigh, NC 27607  
NC License No: P-0288

**PAVEMENT MARKING DETAIL**



TIP NO. X-0002BB	SHEET NO. PMP-10
APPROVED: <i>[Signature]</i>	
DATE: 6-8-12	
SEAL	

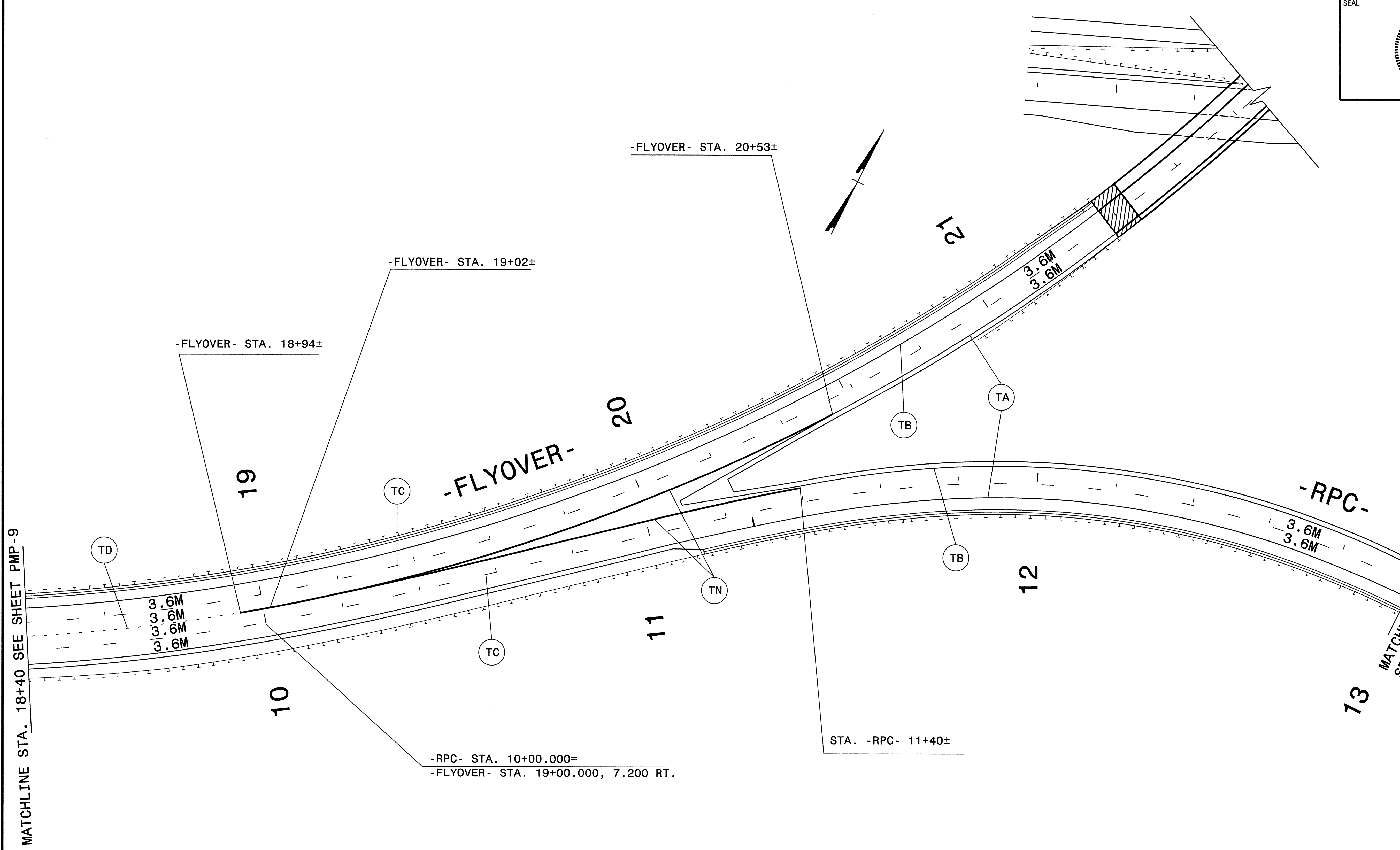

6/7/2012  
F:\Signing & Delinereaction\X-0002BB\X-0002bb\_pm\_d119.dgn  
Florence & Hutcheson

**Florence & Hutcheson**  
CONSULTING ENGINEERS  
5121 Kingdom Way, Suite 100 Raleigh, NC 27607  
NC License No: P-0298

**PAVEMENT MARKING DETAIL**



TIP NO. X-0002BB	SHEET NO. PMP-11
APPROVED: <i>John A. Graves</i>	
DATE: 6-8-12	
SEAL	

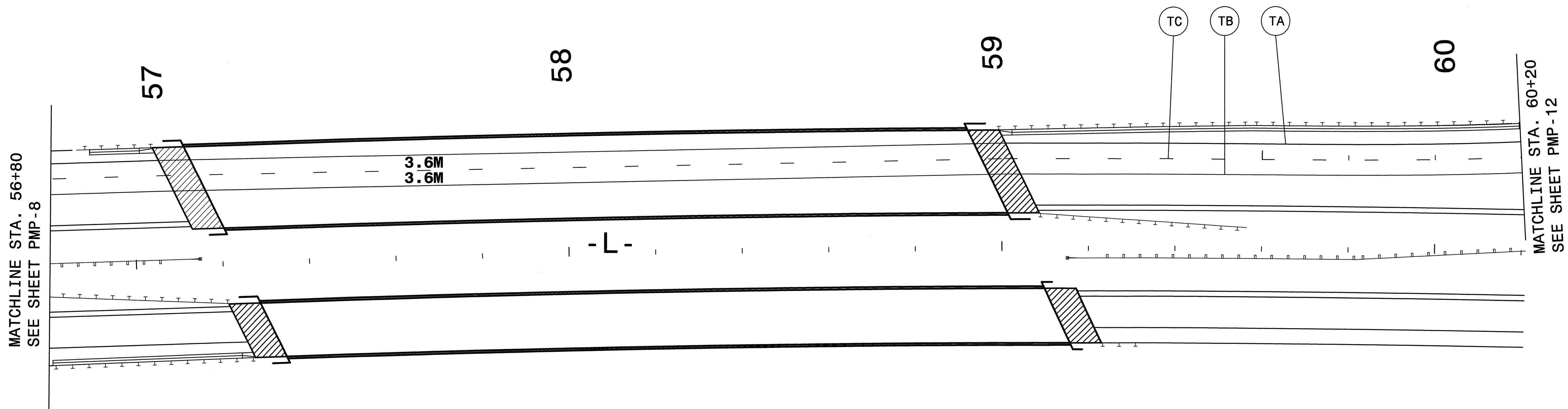
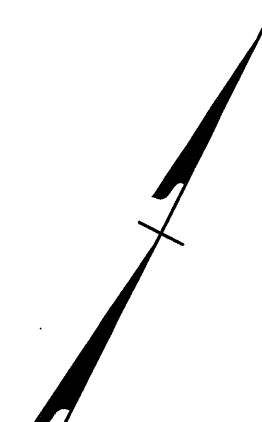

MATCHLINE STA. 56+80  
SEE SHEET PMP-8

MATCHLINE STA. 60+20  
SEE SHEET PMP-12

3.6M  
3.6M

TC

TB

TA

6/7/2012  
F:\Signing & Delineation\X-0002BB\X-0002BB-pm\_dfl.dgn  
Florence & Hutcheson

**Florence & Hutcheson**  
CONSULTING ENGINEERS  
5121 Kingdom Way, Suite 100 Raleigh, NC 27607  
NC License No: F-0258

**PAVEMENT MARKING DETAIL**



TIP NO. X-0002BB	SHEET NO. PMP-12
APPROVED: <i>[Signature]</i>	DATE: 6-8-12
SEAL	

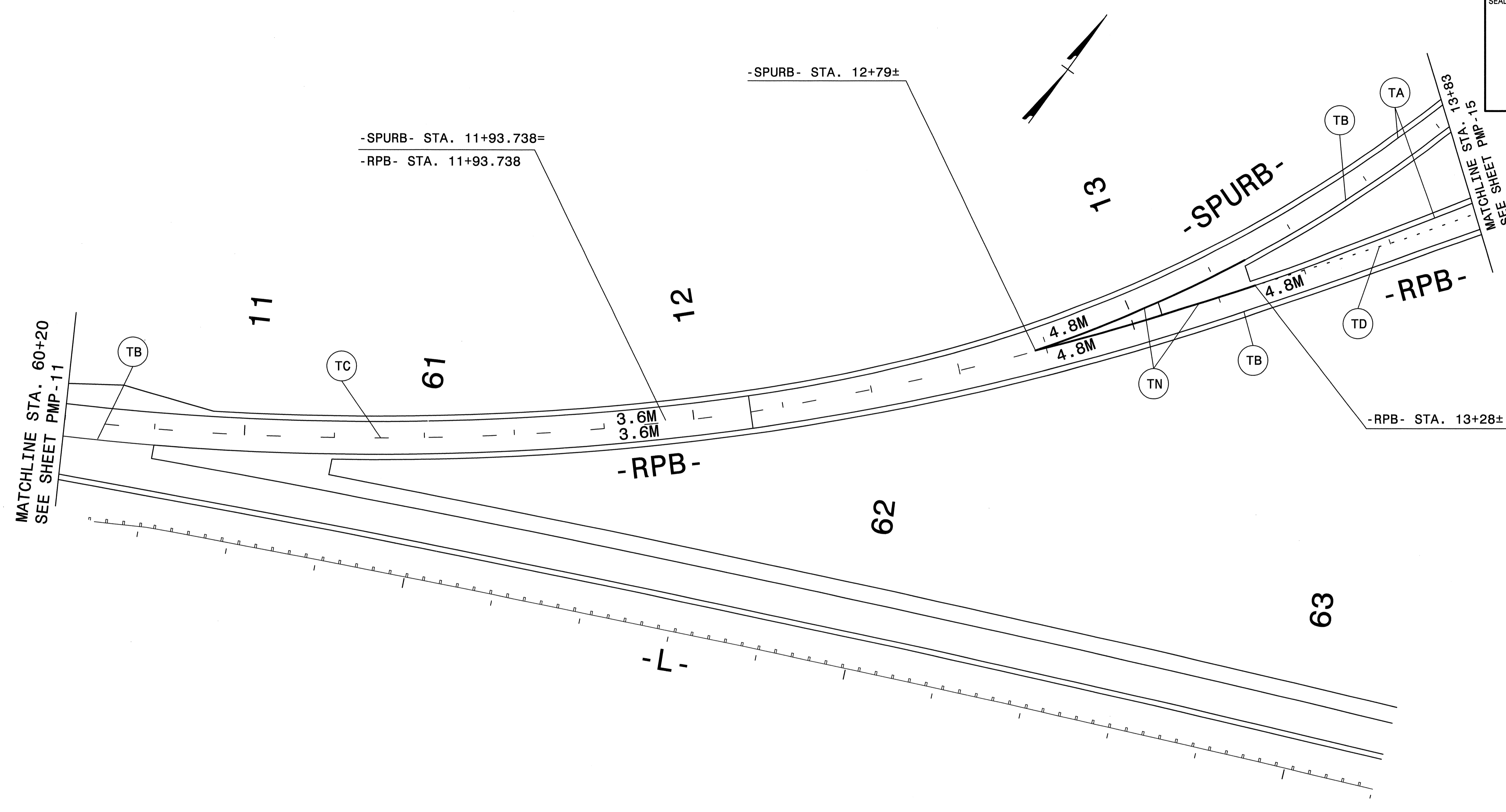

6/7/2012  
F:\Signing & Delin\action\X-0002BB\X-0002BB-pm-dtl12.dgn  
Florence & Hutcheson

**FH** Florence & Hutcheson  
CONSULTING ENGINEERS  
5121 Kingdom Way, Suite 100 Raleigh, NC 27607  
NC License No: F-0258

**PAVEMENT MARKING DETAIL**





TIP NO. X-0002BB	SHEET NO. PMP-13
APPROVED: <i>[Signature]</i>	
DATE: 6-8-12	
SEAL	

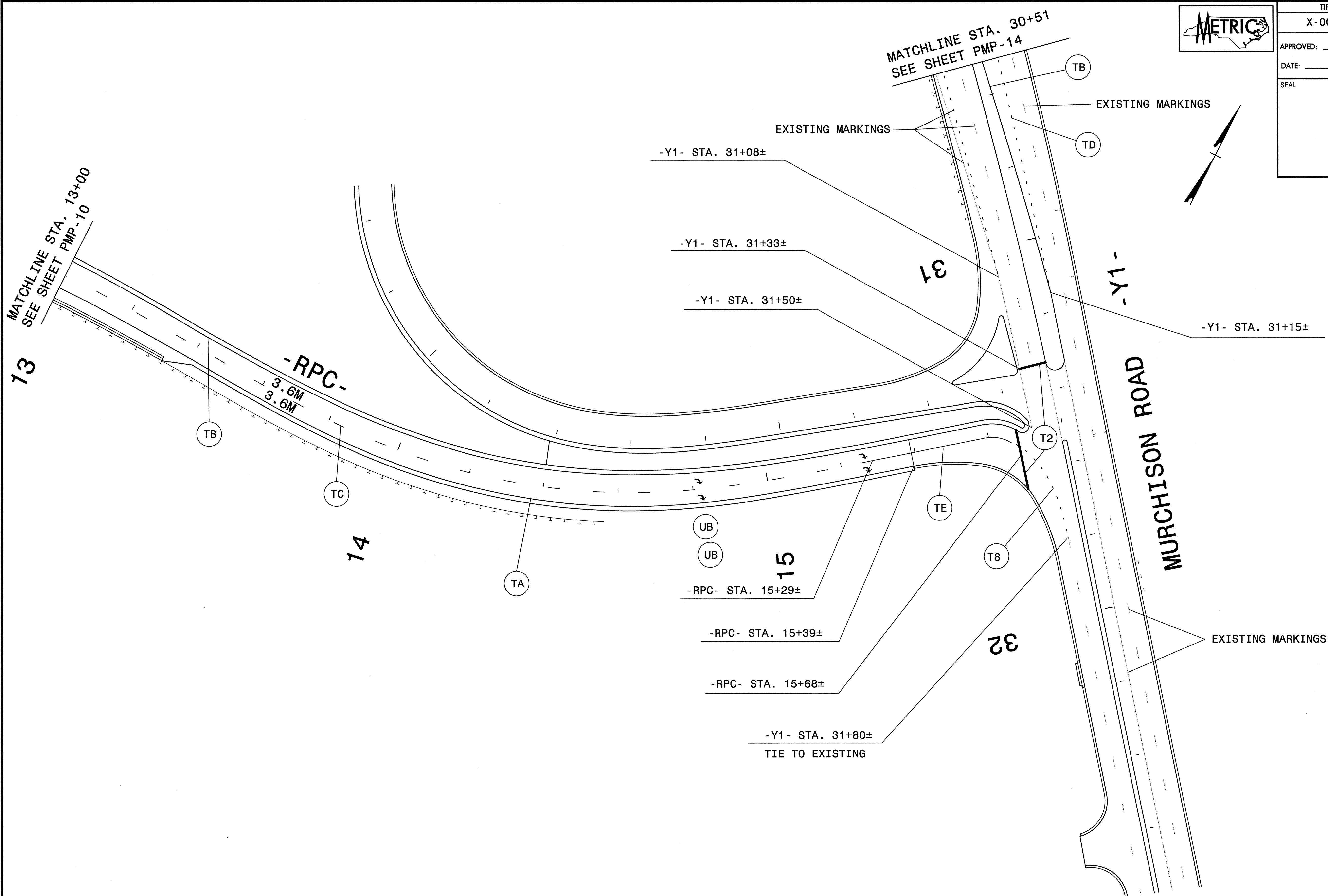
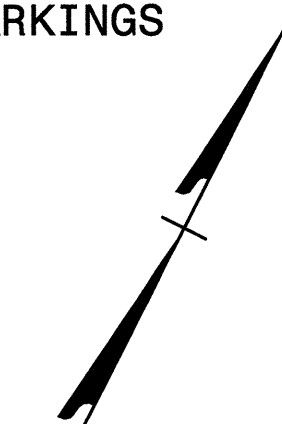

6/7/2012  
F:\Signing & Delineation\X-0002BB\X-0002BB-pm-dt110.dgn  
Florence & Hutcheson

**FH** Florence & Hutcheson  
CONSULTING ENGINEERS  
5121 Kingdom Way, Suite 100 Raleigh, NC 27607  
NC License No: P-0258

**PAVEMENT MARKING DETAIL**



TIP NO. X-0002BB	SHEET NO. PMP-14
APPROVED: <i>[Signature]</i>	
DATE: 6-8-12	
SEAL	

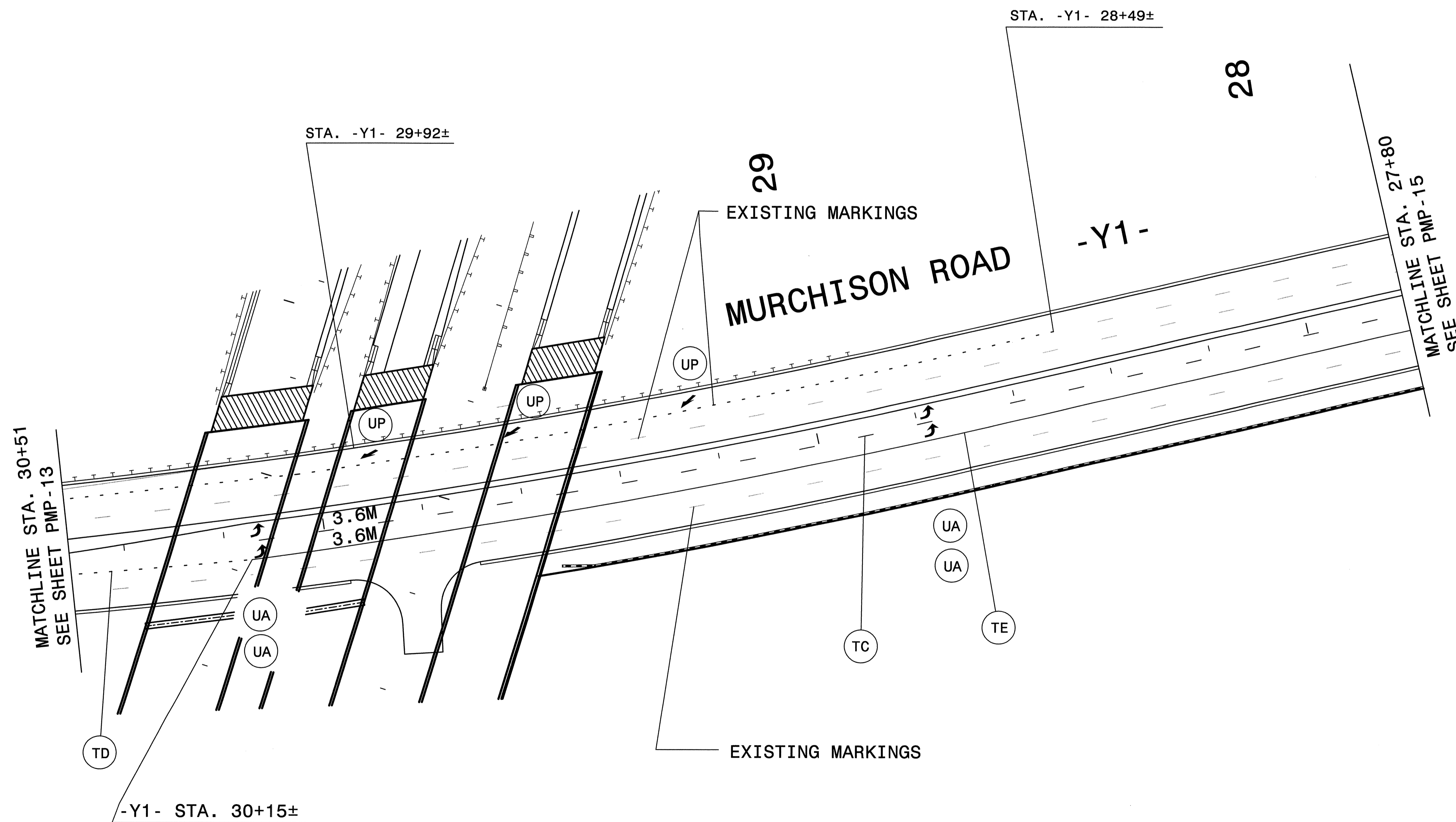
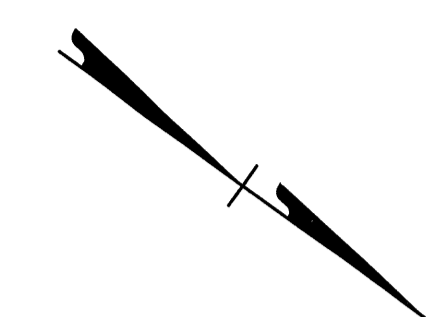

6/7/2012  
 F:\Signing & Delin\action\X-0002BB\X0002BB-pm-df113.dgn  
 Florence & Hutcheson

**Florence & Hutcheson**  
 CONSULTING ENGINEERS  
 5121 Kingdom Way, Suite 100 Raleigh, NC 27607  
NC License No. P-0258

**PAVEMENT MARKING DETAIL**

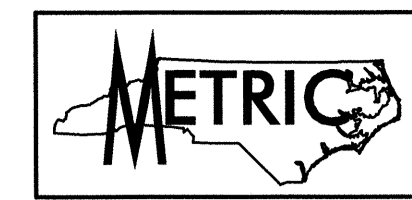

TIP NO. X-0002BB	SHEET NO. PMP-15
APPROVED: <i>[Signature]</i>	DATE: 6-8-12
SEAL	

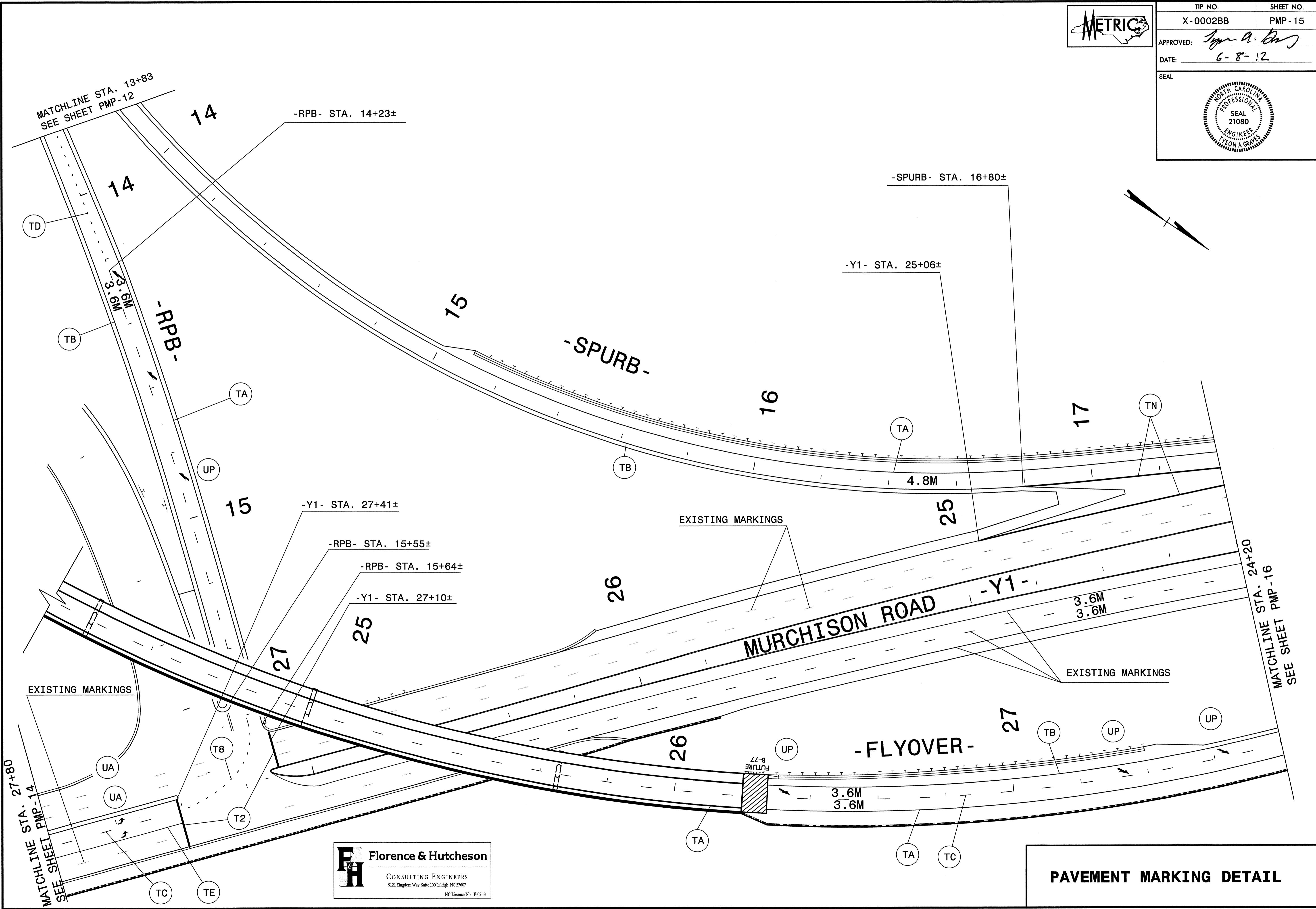

6/7/2012  
F:\Signing & Delineation\X-0002BB\X-0002bb-pm\_dH14.dgn  
Florence & Hutcheson

**FH** Florence & Hutcheson  
CONSULTING ENGINEERS  
5121 Kingdom Way, Suite 100 Raleigh, NC 27607  
NC License No. F-0298

**PAVEMENT MARKING DETAIL**

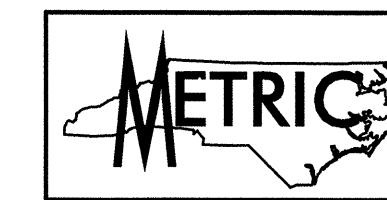

TIP NO. X-0002BB	SHEET NO. PMP-16
APPROVED: <i>[Signature]</i>	
DATE: 6-8-12	
SEAL	

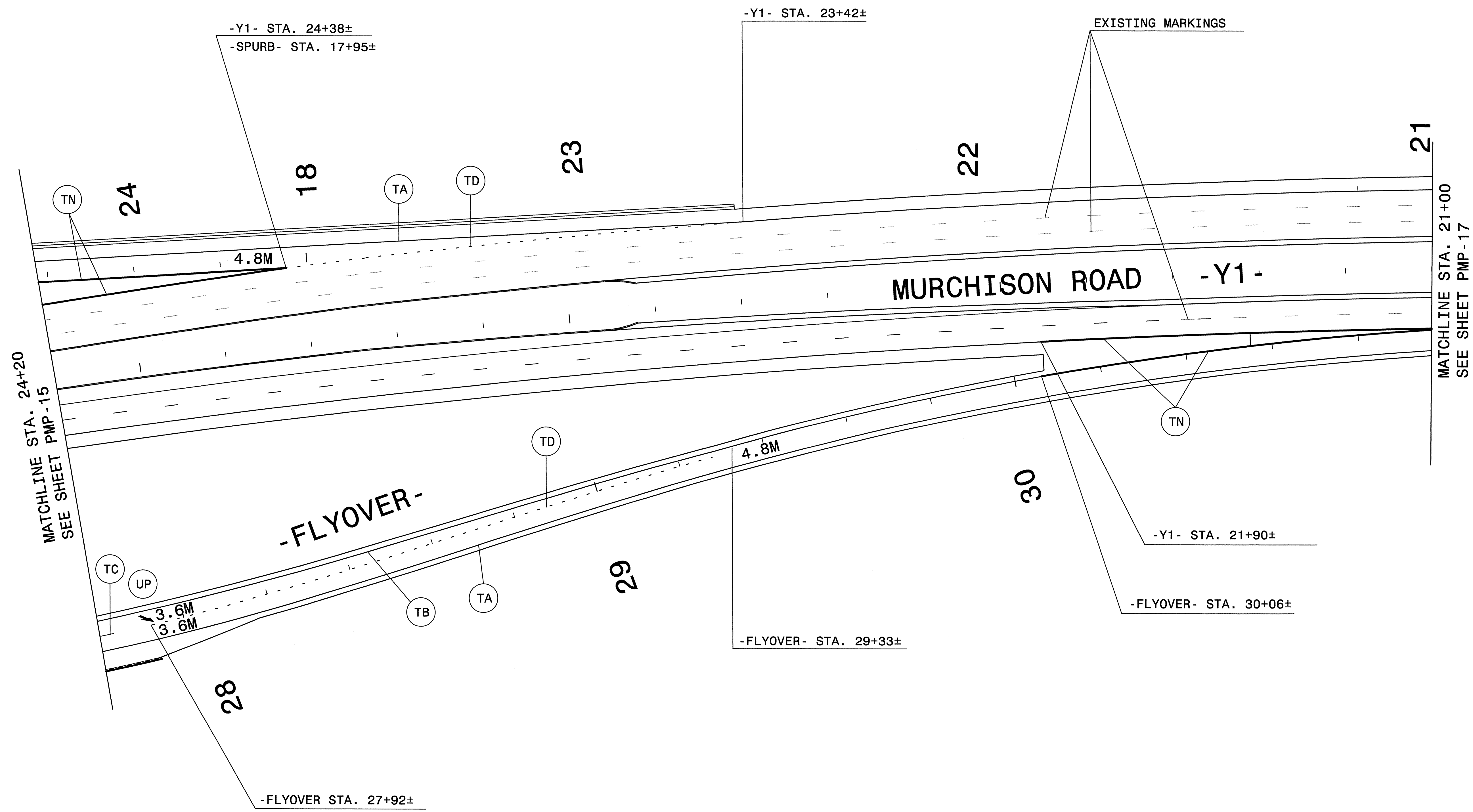

6/7/2012  
 F:\Signing & Delin\action\X-0002BB\X-0002BB-pm-dt115.dgn  
 Florence & Hutcheson

**Florence & Hutcheson**  
 CONSULTING ENGINEERS  
5121 Kingdom Way, Suite 100 Raleigh, NC 27607  
NC License No: P-0288

**PAVEMENT MARKING DETAIL**





TIP NO. X-0002BB	SHEET NO. PMP-17
APPROVED: <i>[Signature]</i>	
DATE: 6-8-12	
SEAL	

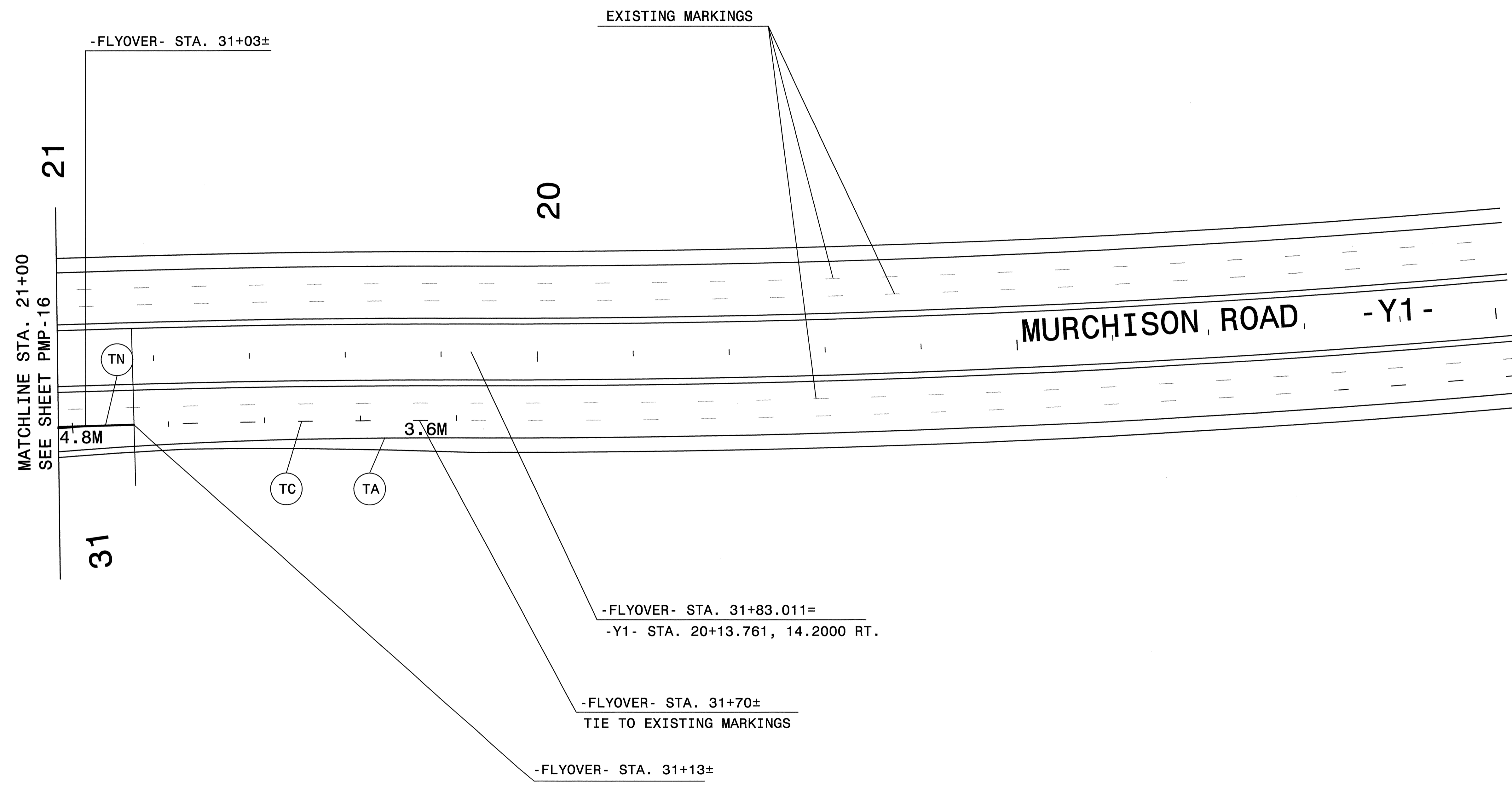
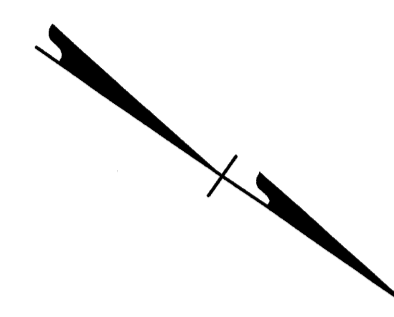

6/7/2012  
 P:\Signing & Delineation\X-0002BB\X-0002BB-pm\_dH16.dgn  
 Florence & Hutcheson

**Florence & Hutcheson**  
 CONSULTING ENGINEERS  
 5121 Kingdom Way, Suite 100 Raleigh, NC 27607  
 NC License No: P-0288

**PAVEMENT MARKING DETAIL**