

STATE OF NORTH CAROLINA
DEPARTMENT OF TRANSPORTATION

PAVEMENT MARKING PLAN
CUMBERLAND COUNTY

LOCATION: SR 1132 (LEGION RD) FROM SR 1363 (ELK RD) TO
SR 1007 (OWEN DR) IN FAYETTEVILLE

TIP NO. U-2809B	SHEET NO. PMP-1
APPROVED: <i>Ayman Alqudwah</i>	
DATE: 5/21/12	
SEAL	
	

T.I.P.: U-2809B

CONTRACT:

U-2809B FINAL PAVEMENT MARKING SCHEDULE

SYMBOL	DESCRIPTION
(FINAL PAVEMENT MARKINGS)	
THERMOPLASTIC (24", 120 MILS)	
T2	WHITE STOPBAR
T3	WHITE CROSSWALK LINE
THERMOPLASTIC (4", 120 MILS)	
TC	10 FT. WHITE SKIP
TD	3FT-9FT SP. WHITE MINISKIP
TE	WHITE SOLID LANE LINE
TI	YELLOW DOUBLE CENTER
T8	2FT-6FT./SP WHITE MINISKIP
T9	2FT-6FT./SP YELLOW MINISKIP
THERMOPLASTIC (4", 90 MILS)	
TA	WHITE EDGELINE
TB	YELLOW EDGELINE
THERMOPLASTIC (8", 90 MILS)	
TN	WHITE GORELINE
TO	WHITE DIAGONAL
TP	YELLOW DIAGONAL
THERMOPLASTIC (8", 120 MILS)	
T13	3'-9' SP. WHITE MINISKIP
TQ	WHITE CROSSWALK LINE
TR	WHITE SOLD LANE LINE
THERMOPLASTICPAVEMENT MARKING CHARACTER (120 MILS)	
UI	ALPHANUMERIC CHAR.
THERMOPLASTICPAVEMENT MARKING SYMBOLS (90 MILS)	
UA	LEFT TURN ARROW
UB	RIGHT TURN ARROW
UC	STRAIGHT ARROW
UE	COMBO.STRAIGHT/RIGHT
UN	24" YIELD LINE TRIANGLE
UT	U-TURN ARROW
(MARKERS)	
PERMANENT RAISED PAVEMENT MARKERS	
MA	YELLOW & YELLOW
MB	CRYSTAL & RED

ROADWAY STANDARD DRAWING

THE FOLLOWING ROADWAY STANDARDS AS APPEAR IN "ROADWAY STANDARD DRAWINGS" - PROJECT SERVICES UNIT - N.C. DEPARTMENT OF TRANSPORTATION - RALEIGH, N.C., DATED JANUARY 2012 ARE APPLICABLE TO THIS PROJECT AND BY REFERENCE HEREBY ARE CONSIDERED A PART OF THESE PLANS:

STD. NO.	TITLE
1205.01	PAVEMENT MARKINGS - LINE TYPES AND OFFSETS
1205.02	PAVEMENT MARKINGS - 2 LANE AND MULTILANE ROADWAYS
1205.04	PAVEMENT MARKINGS - INTERSECTIONS
1205.05	PAVEMENT MARKINGS - TURN LANES
1205.06	PAVEMENT MARKINGS - LANE DROPS
1205.07	PAVEMENT MARKINGS - PEDESTRIAN CROSSWALKS
1205.08	PAVEMENT MARKINGS - SYMBOL AND WORD MESSAGES
1205.09	PAVEMENT MARKINGS - PAINTED ISLANDS
1205.10	PAVEMENT MARKINGS - SCHOOL AREA
1250.01	PAVEMENT MARKER SPACING
1251.01	RAISED PAVEMENT MARKERS - TEMPORARY AND PERMANENT

GENERAL NOTES

THE FOLLOWING GENERAL NOTES APPLY AT ALL TIMES FOR THE DURATION OF THE CONSTRUCTION PROJECT, EXCEPT WHEN OTHERWISE NOTED IN THE PLAN, OR DIRECTED BY THE ENGINEER.

A) INSTALL PAVEMENT MARKINGS AND PAVEMENT MARKERS ON THE FINAL SURFACE AS FOLLOWS:

ROAD NAME	MARKING	MARKER
-L-, -Y17-, -Y19-, & -Y23-	THERMOPLASTIC	PERMANENT RAISED MARKER
-Y10- THRU -Y16-, -Y18-, -Y21-, & -Y22-	THERMOPLASTIC	NONE

- B) TIE PROPOSED PAVEMENT MARKING LINES TO EXISTING PAVEMENT MARKING LINES.
 C) REMOVE/REPLACE ANY CONFLICTING/DAMAGED PAVEMENT MARKINGS AND MARKERS.
 D) PASSING ZONES WILL BE DETERMINED IN THE FIELD AND MUST BE APPROVED BY THE ENGINEER.
 E) STOP BAR LOCATION AT NON-SIGNALIZED INTERSECTIONS MAY BE ADJUSTED AS DIRECTED BY THE ENGINEER.
 F) UNLESS OTHERWISE SPECIFIED, HEATED-IN-PLACE THERMOPLASTIC MAY BE USED IN LIEU OF EXTRUDED THERMOPLASTIC FOR STOP BARS, SYMBOLS, CHARACTERS AND DIAGONALS. IF HEATED-IN-PLACE IS USED, IT SHALL BE PAID FOR USING THE EXTRUDED THERMOPLASTIC PAY ITEM.
 G) MARKERS SHALL BE INSTALLED ACCORDING TO THE NCDOT ROADWAY STANDARD DRAWING 1250.01.

INDEX

SHEET NO.	DESCRIPTION
PMP-1	PAVEMENT MARKING PLAN TITLE SCHEDULE SHEET
PMP-2	CROSSWALK AND STOP BAR PAVEMENT MARKING DETAIL
PMP-2A & 2B	REVISED PAVEMENT MARKING ROADWAY STANDARD DRAWING (1205.6 & 1205.8)
PMP-3-15	PAVEMENT MARKING DETAIL

PLAN PREPARED BY: N.C.D.O.T. SIGNING AND DELINEATION UNIT

AYMAN ALQUDWAH, PE, CPM SIGNING & DELINEATION REGIONAL ENGINEER

BASIR A. RASHID SIGNING & DELINEATION PROJECT DESIGN ENGINEER/TECHNICIAN

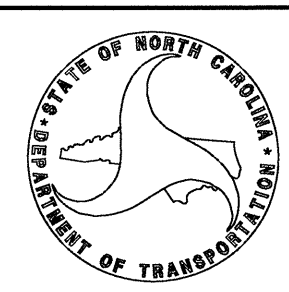

TIP NO. U-2809B	SHEET NO. PMP-2
APPROVED: <i>Amr Alqudrah</i>	
DATE: 5/21/12	
SEAL	
	
REVISIONS	

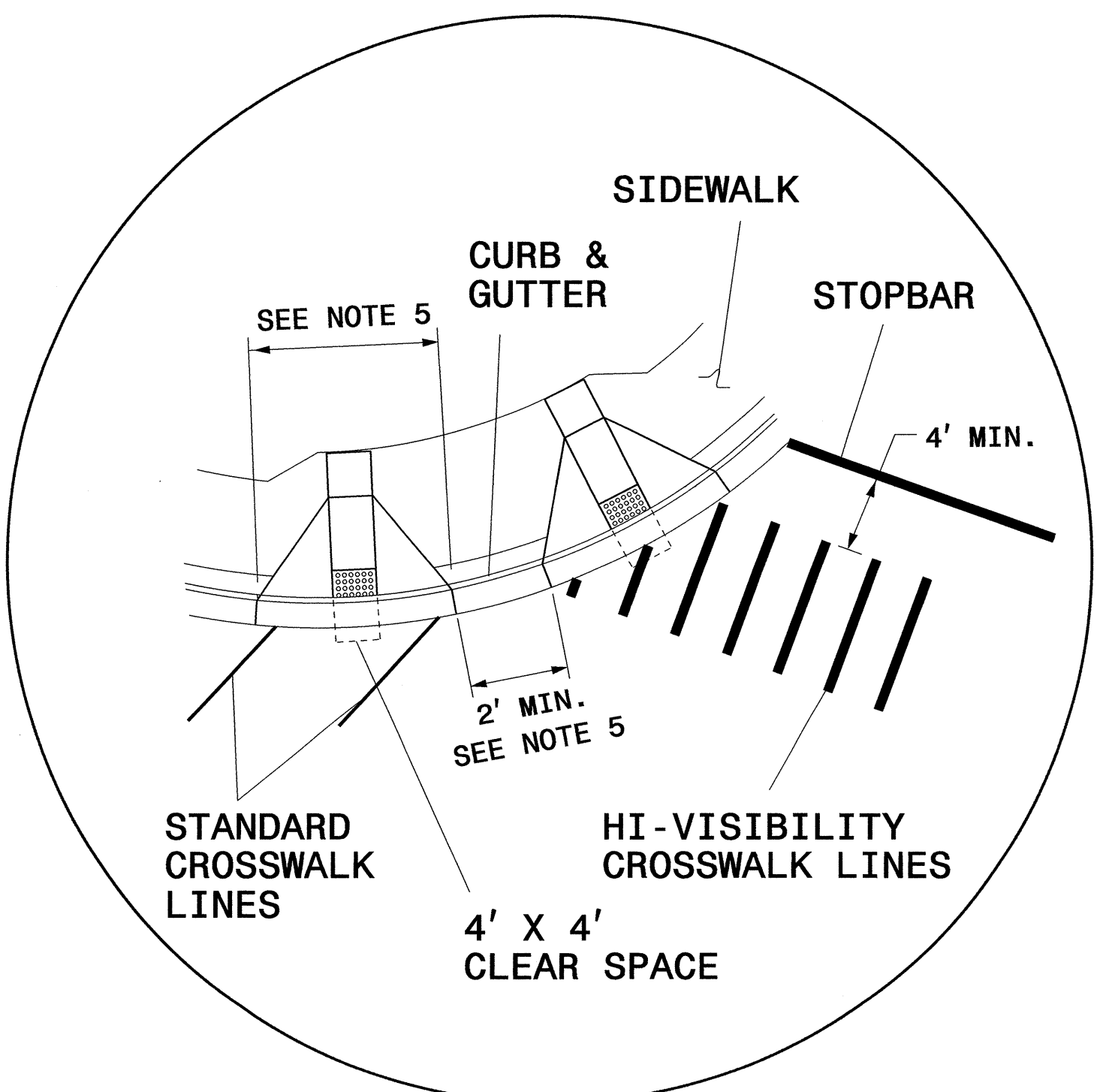
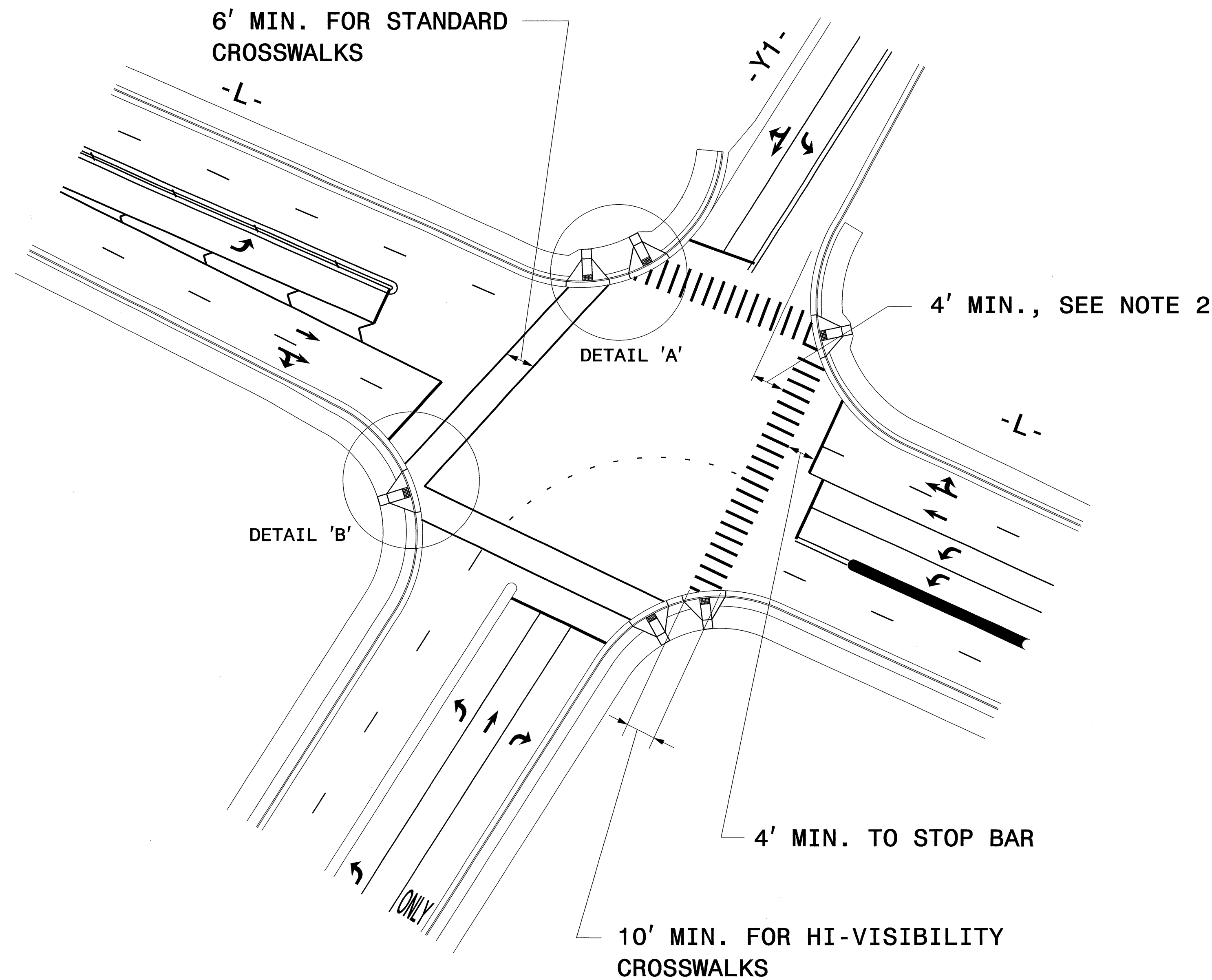

DETAIL 'A'- DUAL CURB RAMPS

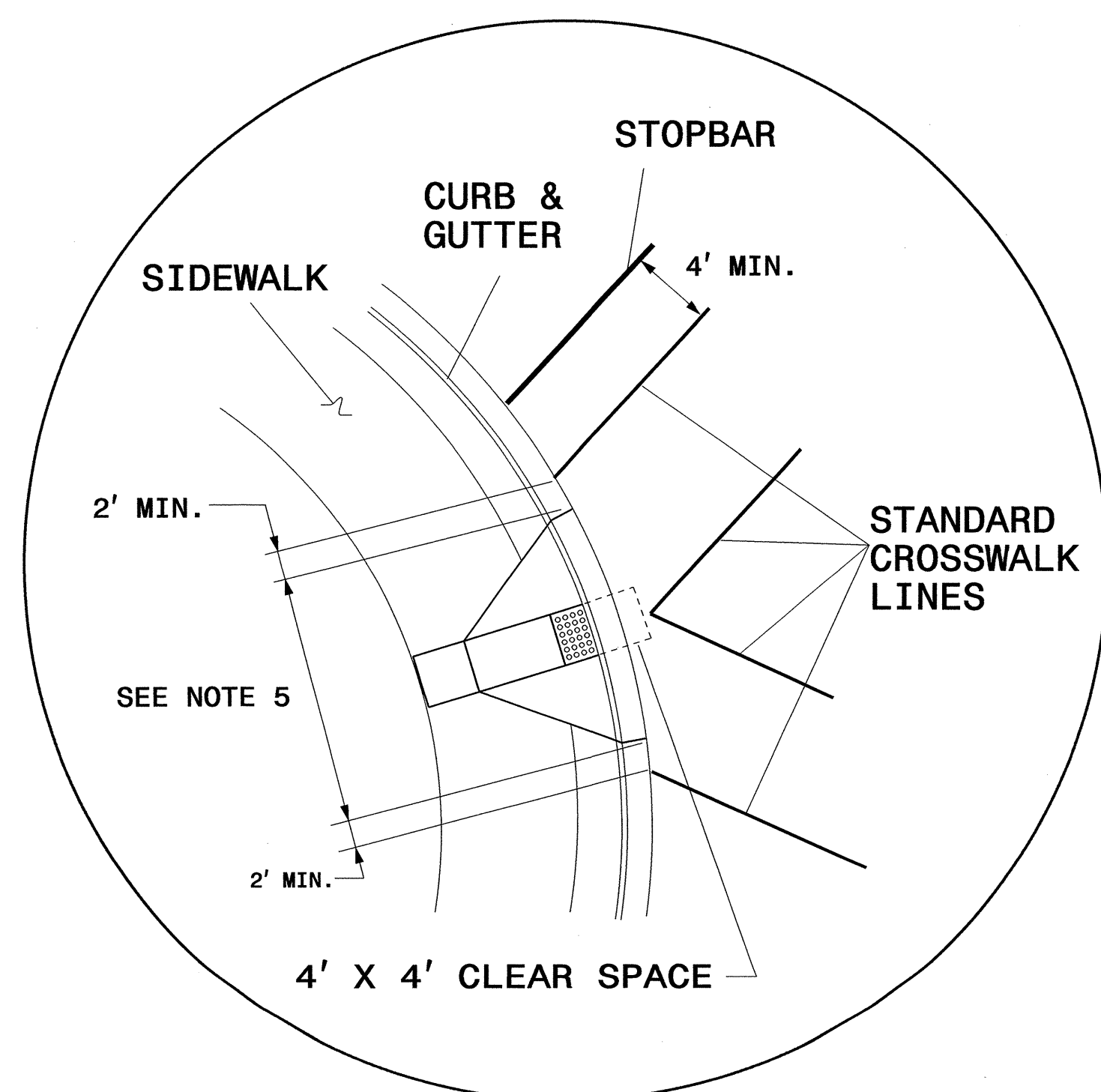

DETAIL 'B'- SINGLE DIAGONAL CURB RAMP

GUIDANCE DETAIL FOR STANDARD AND HI-VISIBILITY CROSSWALKS AT SIGNALIZED OR STOP SIGN CONTROLLED INTERSECTIONS

- NOTES:
- USE DETAILS ABOVE AND THE FOLLOWING NOTES FOR GUIDANCE IN PLACING CROSSWALKS AND STOP BARS NOT STATIONED ON THE DETAIL SHEETS OR WHEN FIELD ADJUSTMENTS REQUIRED MOVING STATIONED MARKINGS AS DIRECTED BY THE ENGINEER. REFER TO NCDOT ROADWAY STANDARD DRAWINGS, MUTCD AND ADA STANDARDS FOR ADDITIONAL GUIDANCE.
 - SET BACK DISTANCE FROM INSIDE CROSSWALK MARKING TO NEAREST EDGE OF TRAVEL IS 4' MIN.
 - BEYOND THE BOTTOM GRADE BRAKE, A CLEAR SPACE OF 4' X 4' MINIMUM SHALL BE PROVIDED WITHIN THE WIDTH OF THE CROSSWALK.
 - SINGLE DIAGONAL CURB RAMPS WITH FLARED SIDES SHALL HAVE A SEGMENT OF CURB 2 FEET LONG MINIMUM LOCATED ON EACH SIDE OF THE CURB RAMP AND WITHIN THE MARKED CROSSING, SEE DETAIL 'B'.
 - CURB RAMPS SHALL BE CONSTRUCTED IN ACCORDANCE TO THE LATEST NCDOT ROADWAY STANDARD DRAWINGS.

CROSSWALK AND STOP BAR PAVEMENT MARKING DETAIL

18-MAY-2012 11:11
 P:\IP\Projects\U-2809B\Traffic\Signing\CADD\PMF\U-2809B_Sgn_PMF_Sheet-I-2B.dgn
 brashid - AT 1E247793

2/01/12

TIP NO. U-2809B	SHEET NO. PMP-2A
APPROVED: <i>[Signature]</i>	
DATE: 5/21/12	
SEAL	
	

STATE OF NORTH CAROLINA
 DEPT. OF TRANSPORTATION
 DIVISION OF HIGHWAYS
 RALEIGH, N.C.

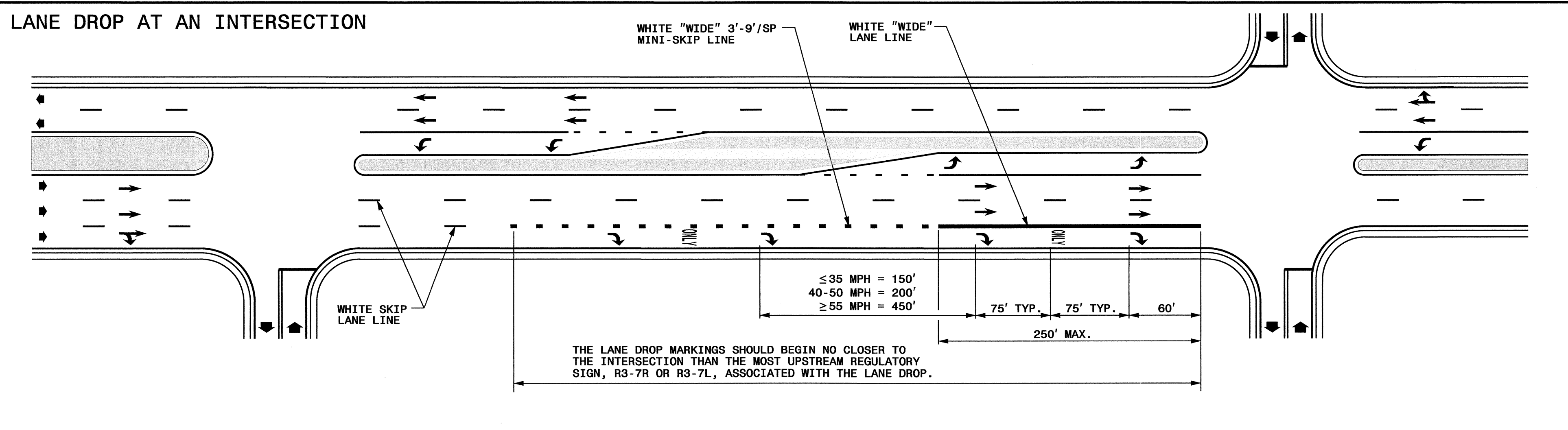

STATE OF NORTH CAROLINA
 DEPT. OF TRANSPORTATION
 DIVISION OF HIGHWAYS
 RALEIGH, N.C.

ENGLISH DETAIL DRAWING FOR
PAVEMENT MARKINGS
 LANE DROPS

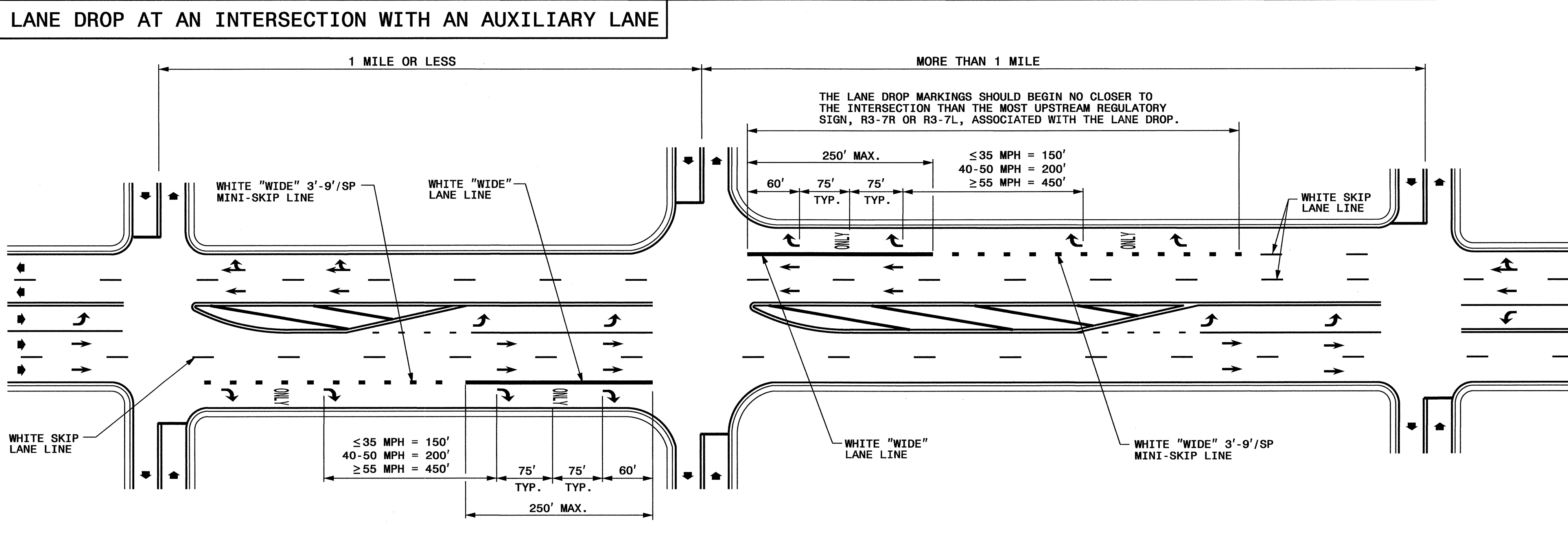

ENGLISH DETAIL DRAWING FOR
PAVEMENT MARKINGS
 LANE DROPS

- GENERAL NOTES:**
- USE THE GUIDANCE SHOWN ON THE ABOVE DETAILS IN CONJUNCTION WITH INTERSECTION GUIDANCE SHOWN ON ROADWAY STANDARD DRAWING 1205.04.
 - LANE LINES INDICATED AS "WIDE" SHALL BE AT LEAST TWICE THE WIDTH OF THE NORMAL LINE.

LEGEND	
W = WIDTH OF TRAVEL LANE	↩ ONLY PAVEMENT MARKING SYMBOLS & CHARACTERS
➔ DIRECTION OF TRAFFIC FLOW	

SHEET 1 OF 3
1205D06

SHEET 1 OF 3
1205D06

**REVISED PAVEMENT MARKING
ROADWAY STANDARD DRAWING**

18-MAY-2012 14:12
 P:\IT\Projects-U\2809B\Traffic\CADD\PMU-2809B_Sgn_PMP_Sheet1-2B.dgn
 brashid AT 1E247799

TIP NO. U-2809B	SHEET NO. PMP-2B
APPROVED: <i>[Signature]</i>	
DATE: 5/21/12	
SEAL	
	

STATE OF NORTH CAROLINA
DEPT. OF TRANSPORTATION
DIVISION OF HIGHWAYS
RALEIGH, N.C.

1-12

MULTI-LANE WIDTH "SCHOOL"

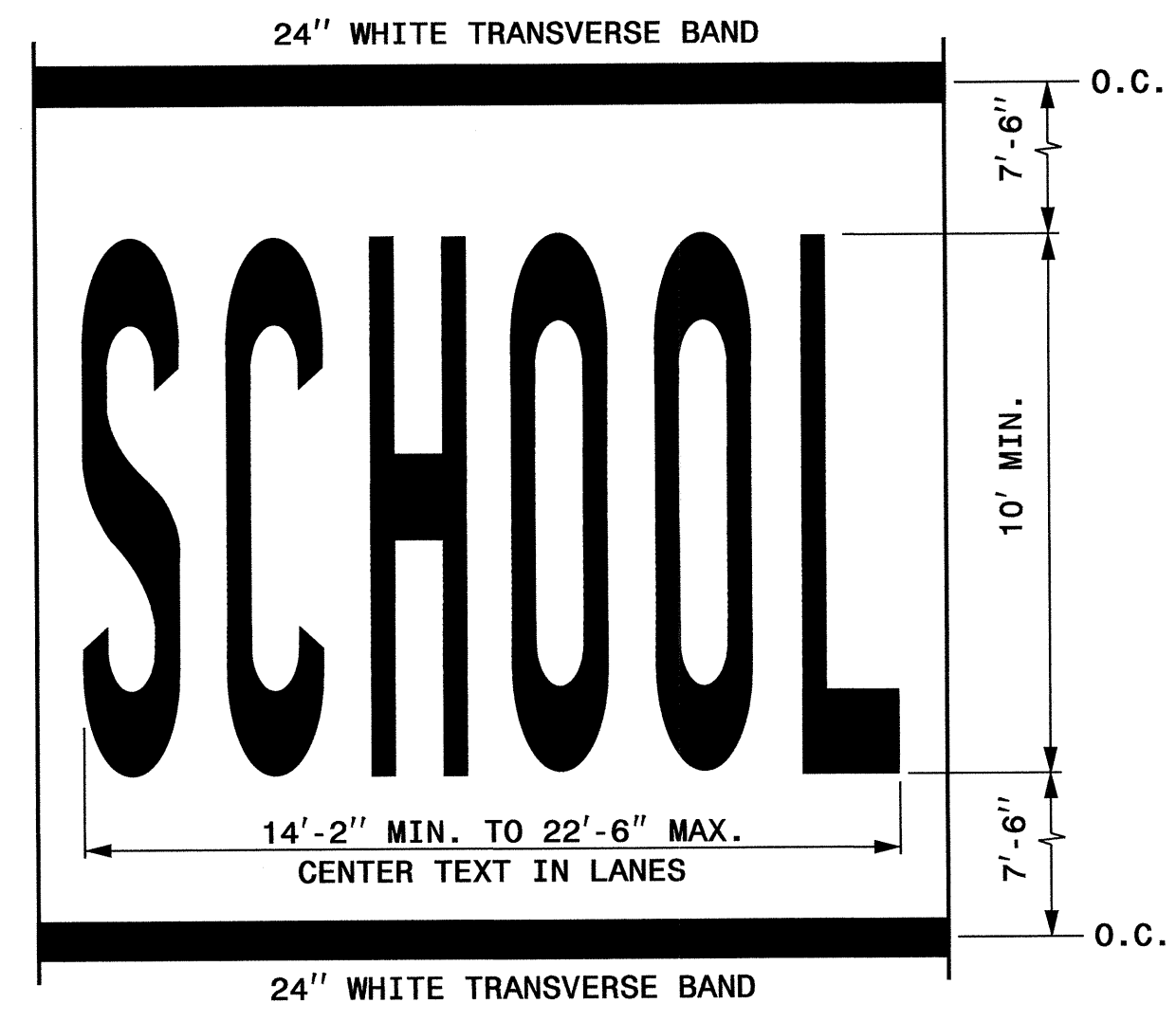

LETTER HEIGHT = 10' MIN.
LETTER WIDTH = 20"
SPACING = 10" MIN./30" MAX. (USE EQUAL SPACING BETWEEN LETTERS)

SINGLE LANE WIDTH "SCHOOL"

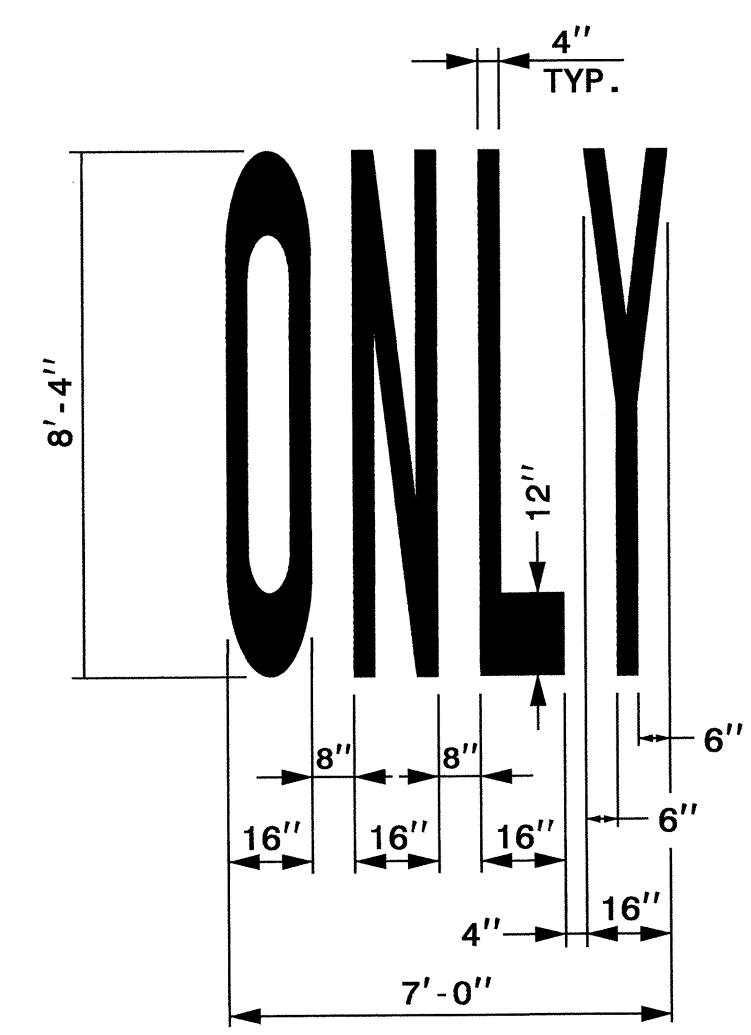
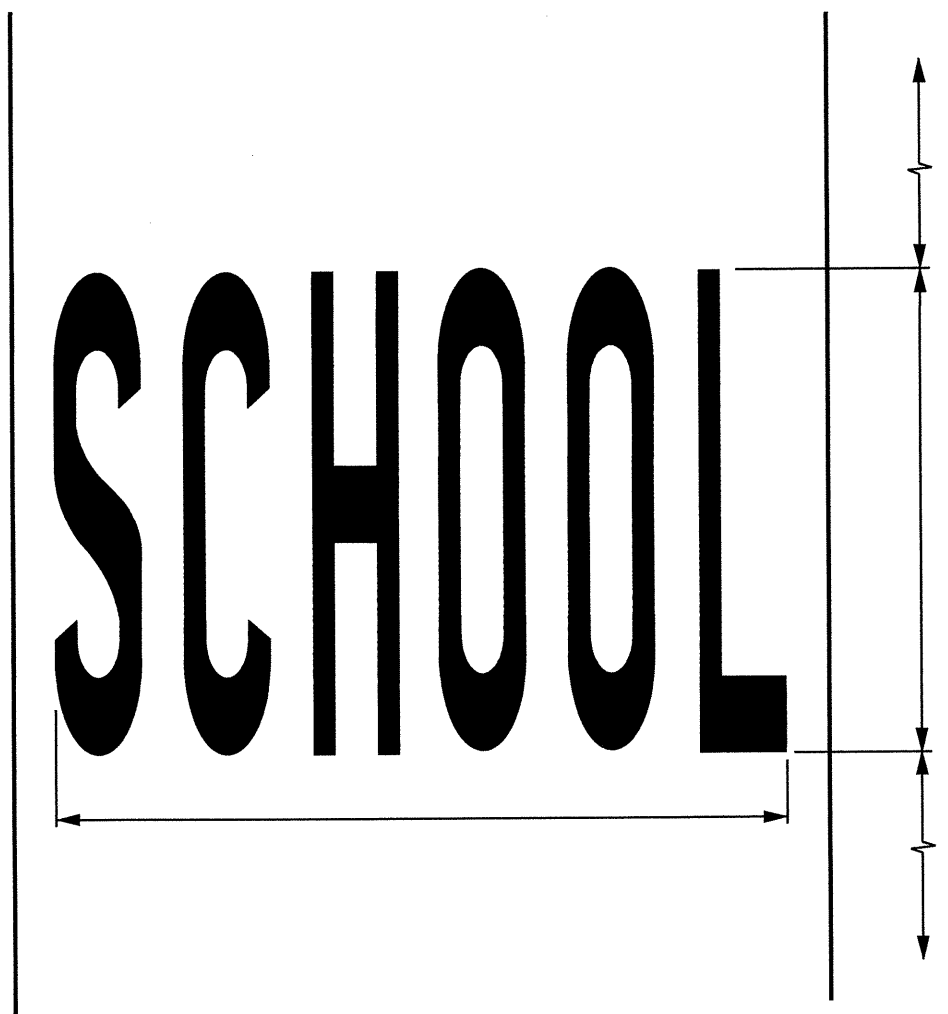

PAVEMENT MARKINGS
SYMBOLS AND WORD MESSAGES

SHEET 3 OF 8

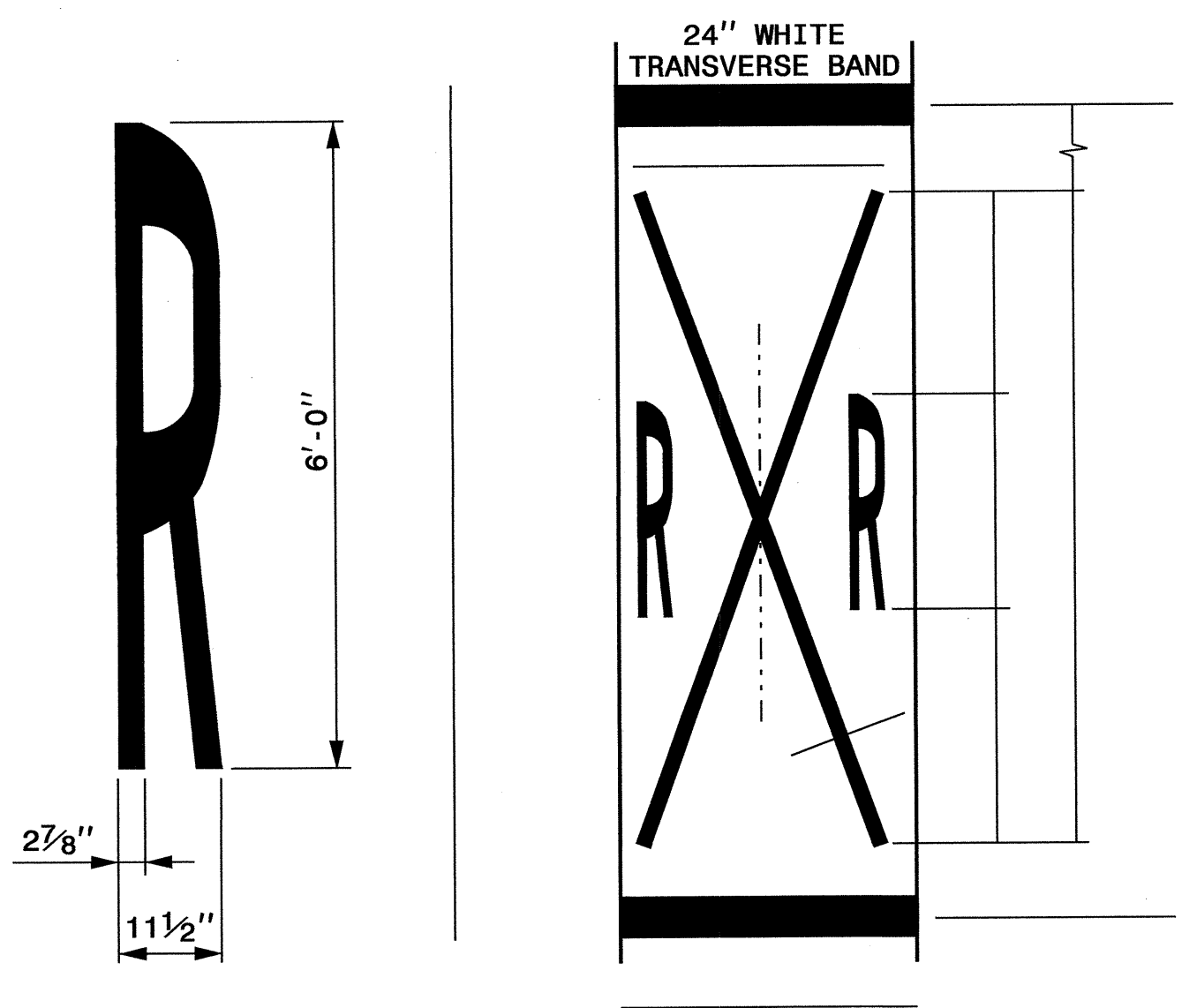

LANE WIDTH (FEET)	WIDTH OF "X" (FEET)
8' ≤ W ≤ 9'	7'
9' < W ≤ 12'	8'
W > 12'	10'

STATE OF NORTH CAROLINA
DEPT. OF TRANSPORTATION
DIVISION OF HIGHWAYS
RALEIGH, N.C.

1-12

PAVEMENT MARKINGS
SYMBOLS AND WORD MESSAGES

SHEET 3 OF 8

REVISED PAVEMENT MARKING
ROADWAY STANDARD DRAWING

TIP NO. U-2809B	SHEET NO. PMP-3
APPROVED: <i>[Signature]</i>	
DATE: 5/21/12	
SEAL	

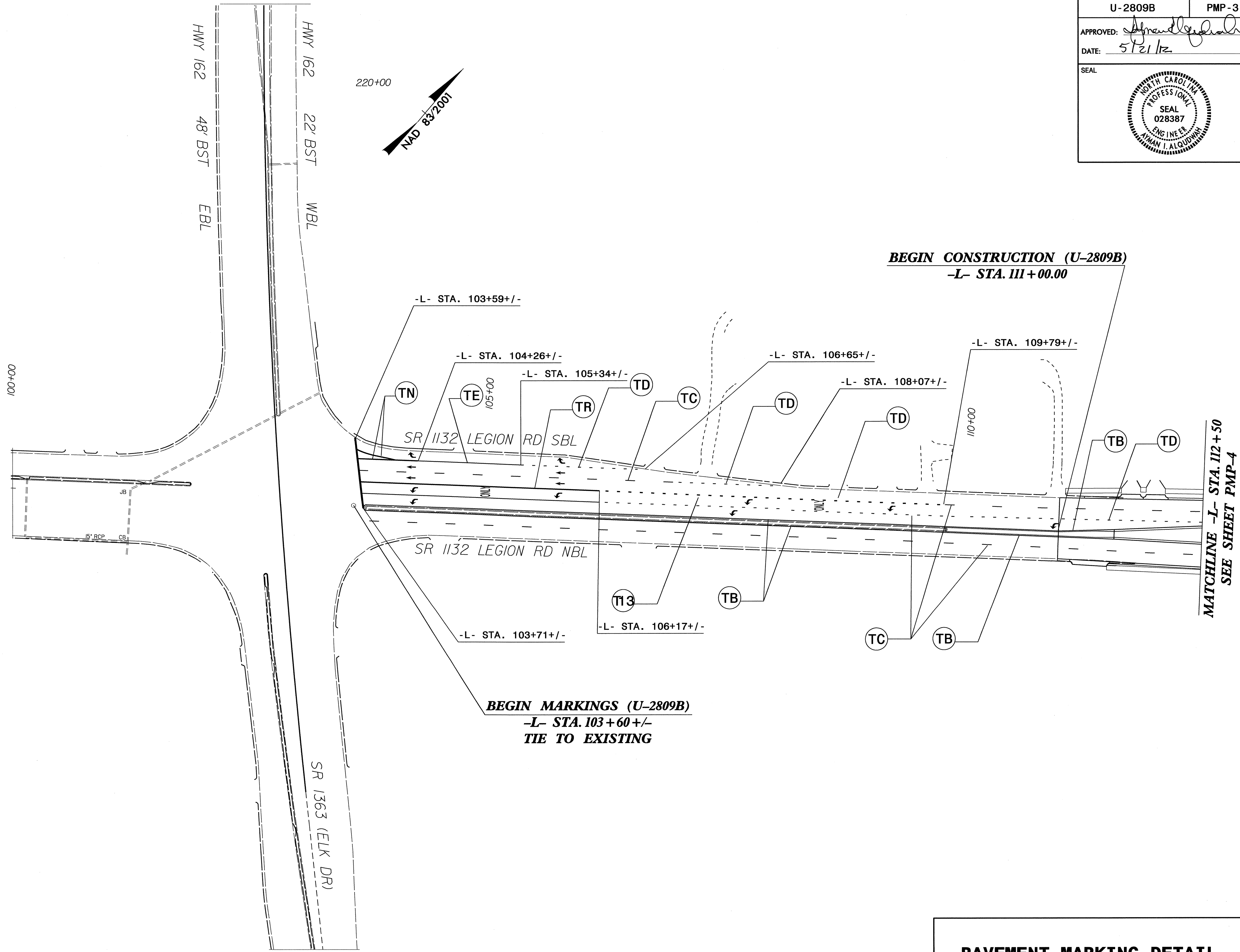

PAVEMENT MARKING DETAIL

18-MAY-2012 11:41
 P:\TIP\Projects-U\U2809B\Traffic\Signing\CADD\PMU\U-2809B_Sgn_PMP_Sheet-3.dgn
 brashid

TIP NO.	SHEET NO.
U-2809B	PMP-4
APPROVED: <i>[Signature]</i>	
DATE: 5/21/12	
SEAL	

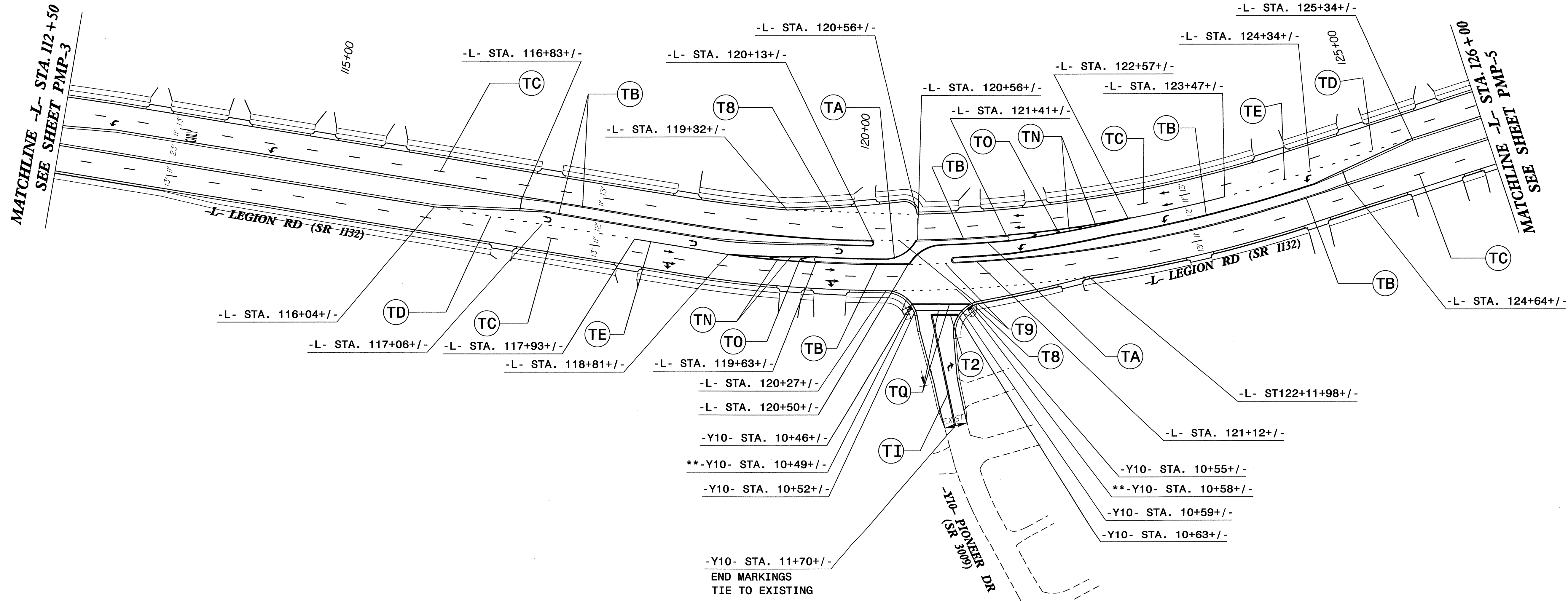
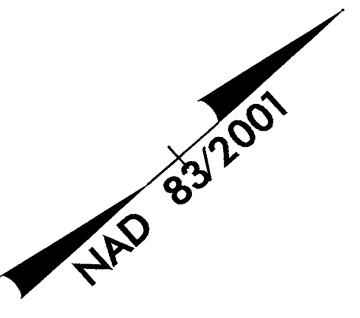
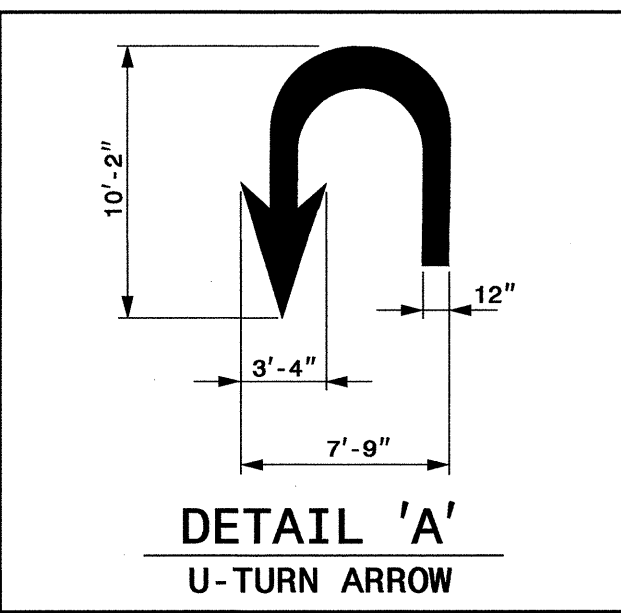

** CENTER OF CURB RAMP

PAVEMENT MARKING DETAIL

18-MAY-2012 11:41
 P:\TIP\Projects-U\U2809B\Traffic\Signing\CADD\PMU-2809B_Sgn_PMP_Sheet-4.dgn
 AT: TE247799
 by: oshid

TIP NO.	SHEET NO.
U-2809B	PMP-7
APPROVED: <i>[Signature]</i>	
DATE: 5/21/12	
SEAL	

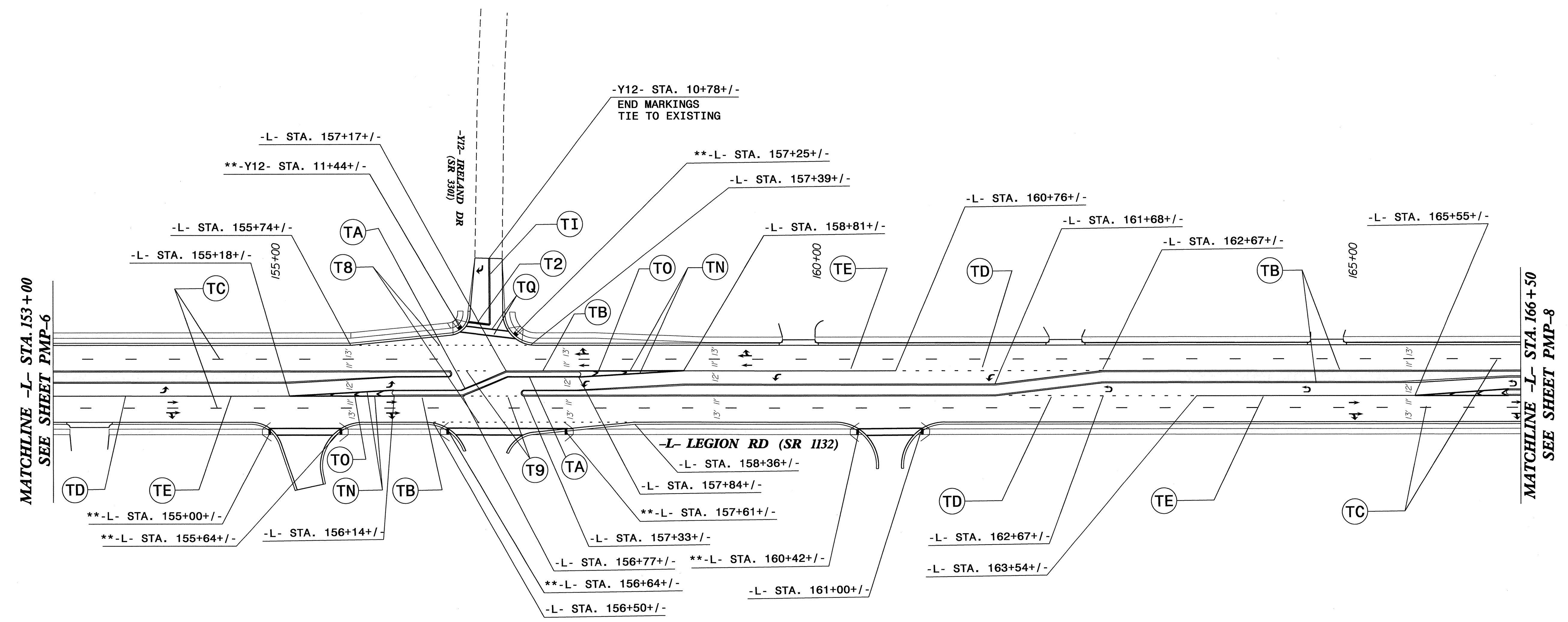
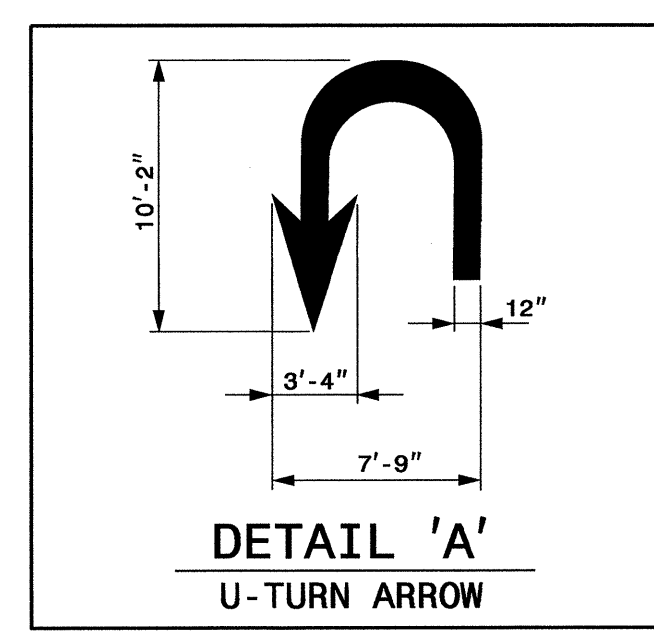

** CENTER OF CURB RAMP

PAVEMENT MARKING DETAIL

18-MAY-2012 11:16
 P:\TIP\Projects-U\U2809B\Traffic\Signing\CADD\PMP-U-2809B_sign_PMP_Sheet1-7.dgn
 bf\ashid

TIP NO.	SHEET NO.
U-2809B	PMP-9
APPROVED: <i>Sydney [Signature]</i>	
DATE: 5/21/12	
SEAL	

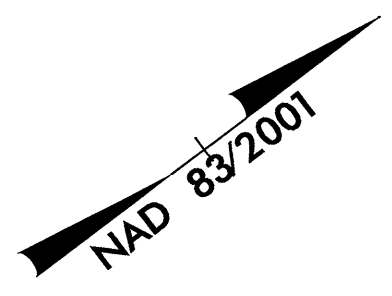

MATCHLINE -L- STA. 180+00
SEE SHEET PMP-8

MATCHLINE -L- STA. 193+50
SEE SHEET PMP-10

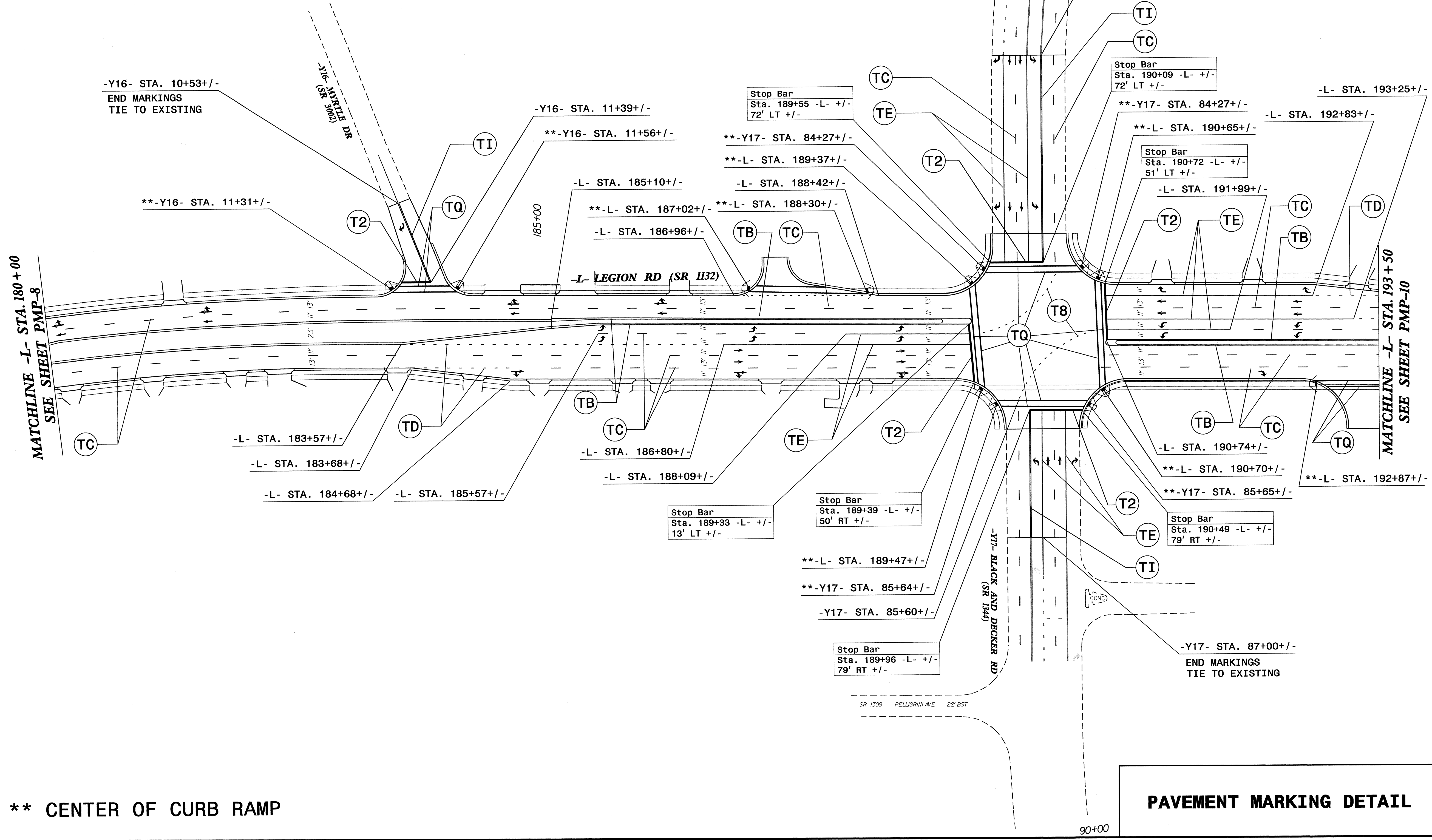

** CENTER OF CURB RAMP

PAVEMENT MARKING DETAIL

18-MAY-2012 11:18 P:\TIP\Projects\U-2809B\Traffic\Signing\CADD\PMF\U-2809B_Sgn_PMP_Sheet-9.dgn
brashid AT 1E241793

TIP NO.	SHEET NO.
U-2809B	PMP-10
APPROVED: <i>[Signature]</i>	
DATE: 5/21/12	
SEAL	

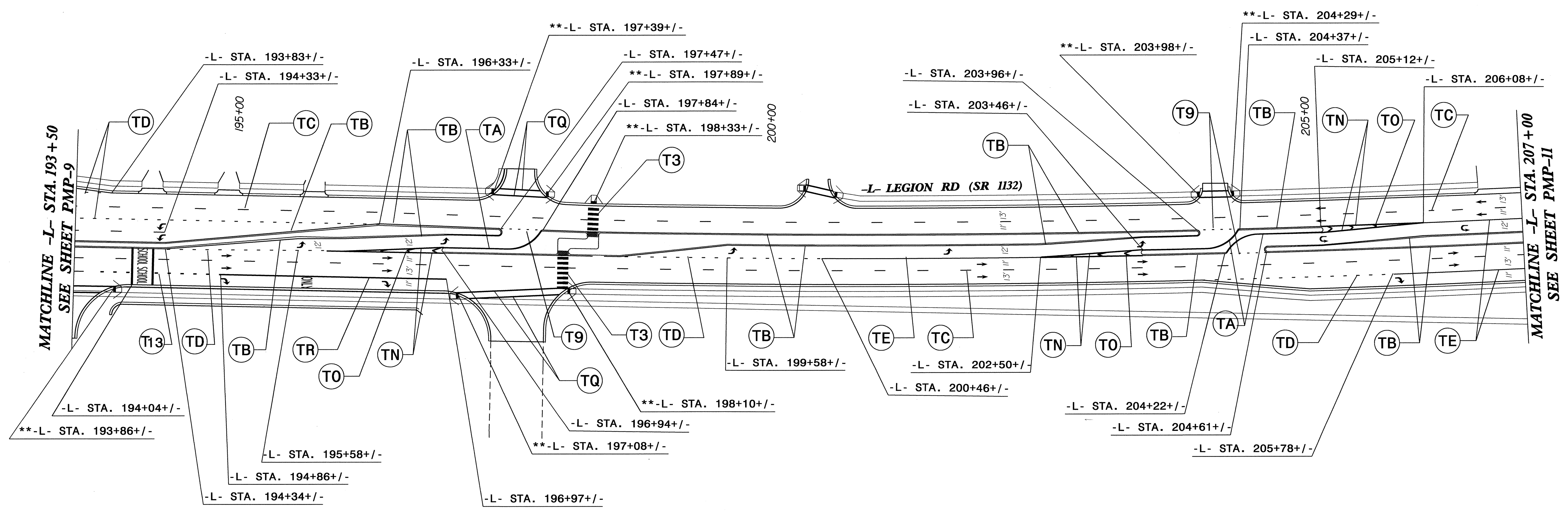
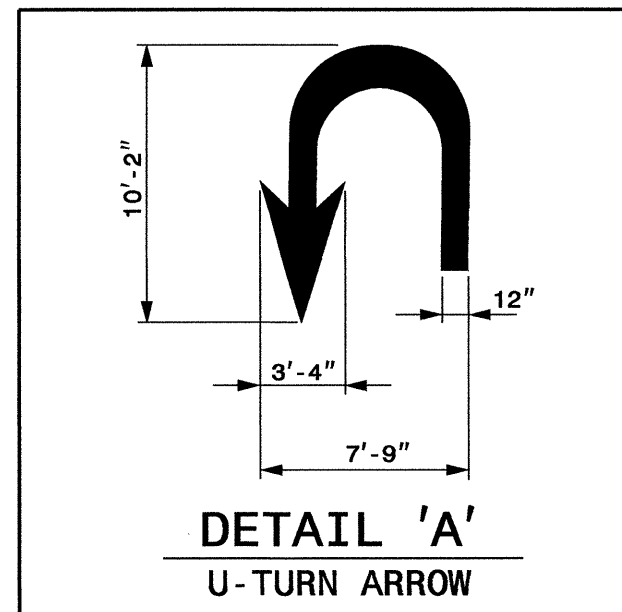

**CENTER OF CURB RAMP

PAVEMENT MARKING DETAIL

I:\MAY-2012\1119
 P:\TIP\Projects-U\U2809B\Traffic\Signing\CADD\MP-U-2809B_Sgn_PMP_Sheet-10.dgn
 AT TE247799
 brashid

TIP NO. U-2809B	SHEET NO. PMP-11
APPROVED: <i>[Signature]</i>	
DATE: 5/21/12	
SEAL	

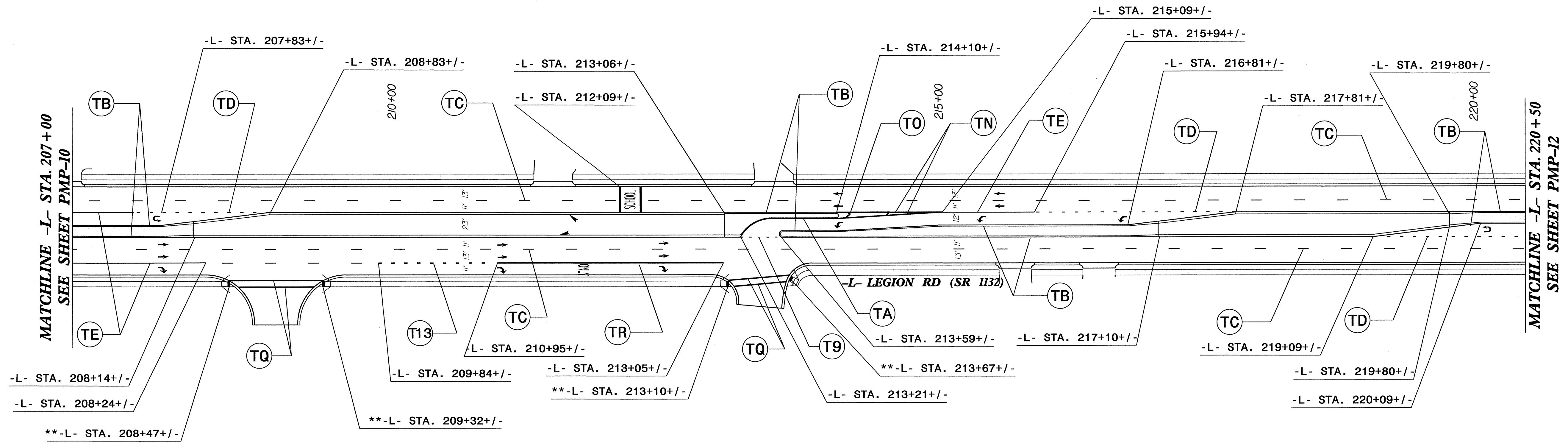
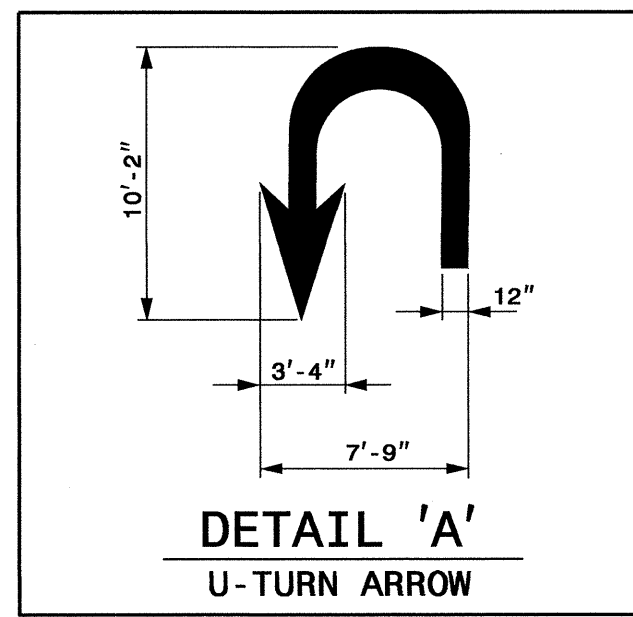

18-MAY-2012 11:20
 P:\IP\Projects-U\U2809B\Traffic\Signing\CADD\MP-U-2809B_Sgn_PMP_Sheet-11.dgn
 brashid AT TE247799

**** CENTER OF CURB RAMP**

PAVEMENT MARKING DETAIL

TIP NO. U-2809B	SHEET NO. PMP-12
APPROVED: <i>[Signature]</i>	
DATE: 5/21/12	
SEAL	

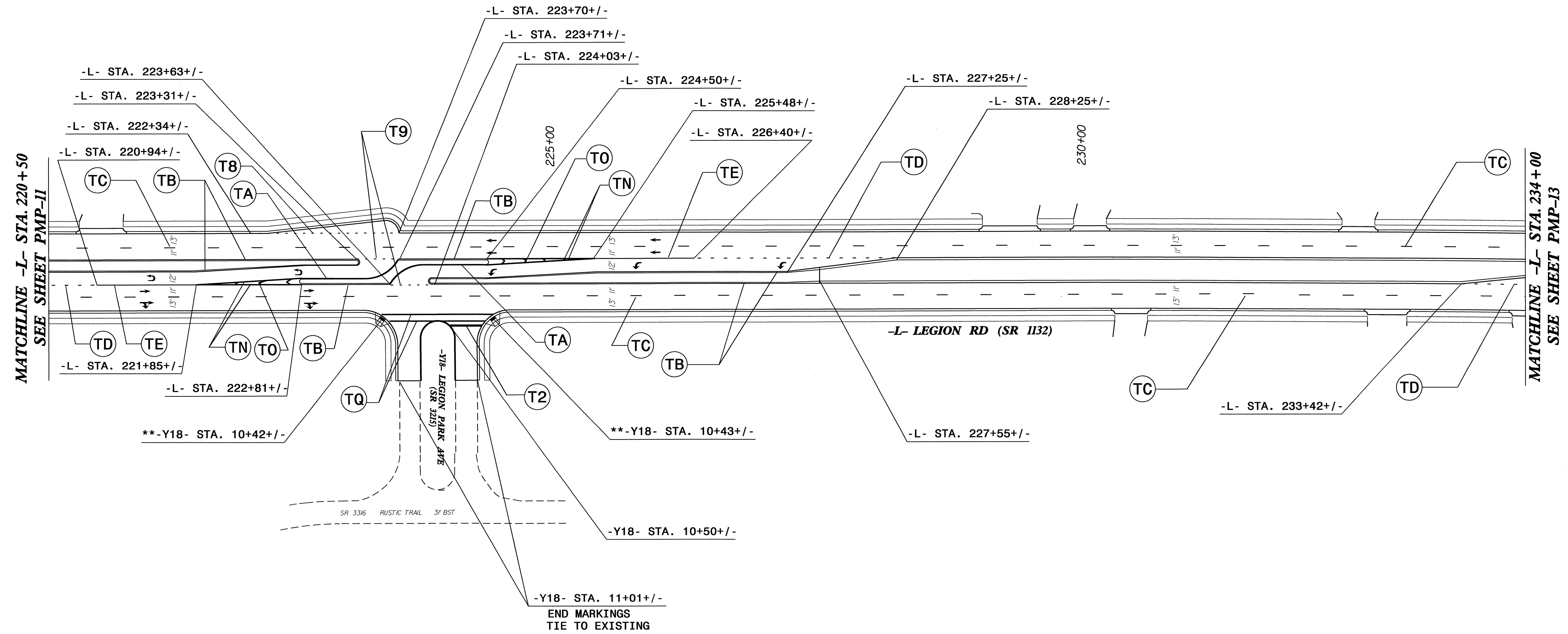
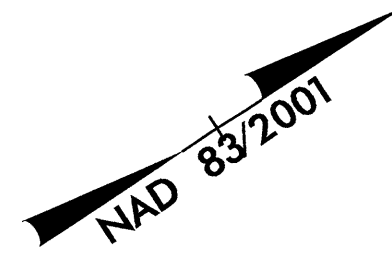
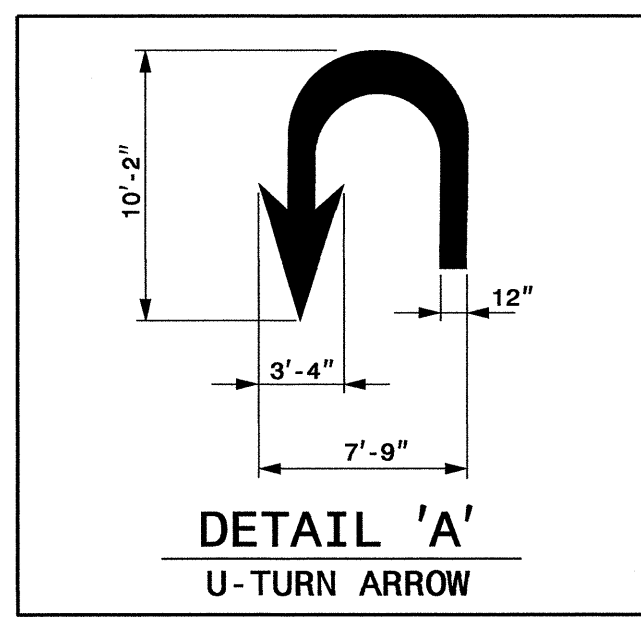

** CENTER OF CURB RAMP

PAVEMENT MARKING DETAIL

18-MAY-2012 11:21
 P:\TIPProjects-U\U2809B\Traffic\Signing\CADD\PMU-2809B_Sgn_PMP_Sheet-12.dgn
 brashid AT TE247799

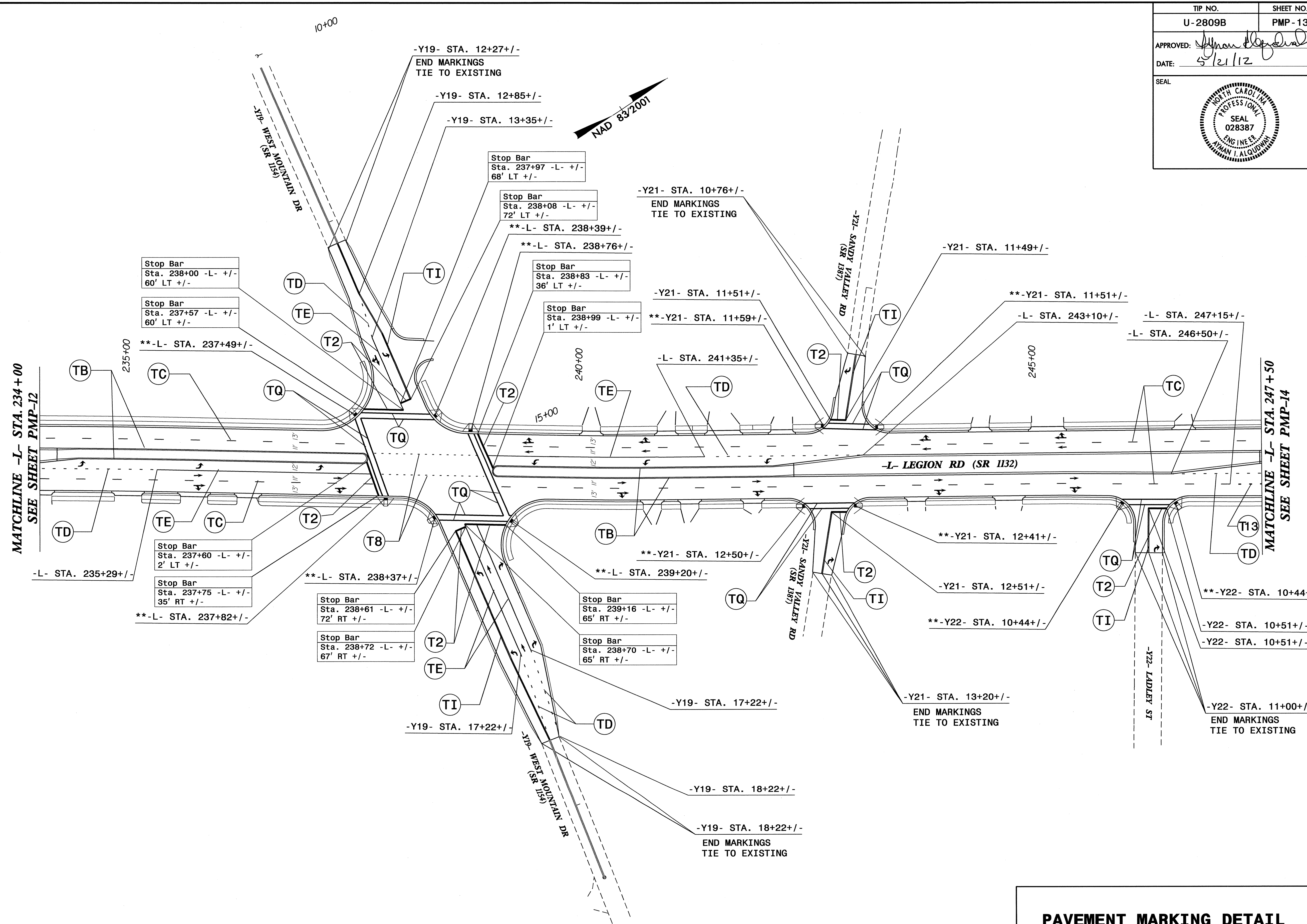

TIP NO.	SHEET NO.
U-2809B	PMP-13
APPROVED: <i>[Signature]</i>	
DATE: 5/21/12	
SEAL	



**** CENTER OF CURB RAMP**

PAVEMENT MARKING DETAIL

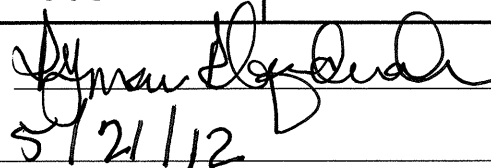
18-MAY-2012 11:21
 P:\TIP\Projects\U-2809B\Traffic\Signing\CADD\PMU-U-2809B_Sgn_PMP_Sheet-13.dgn
 br:ashid

TIP NO.	SHEET NO.
U-2809B	PMP-15
APPROVED: 	
DATE: 5/21/12	
SEAL	
	

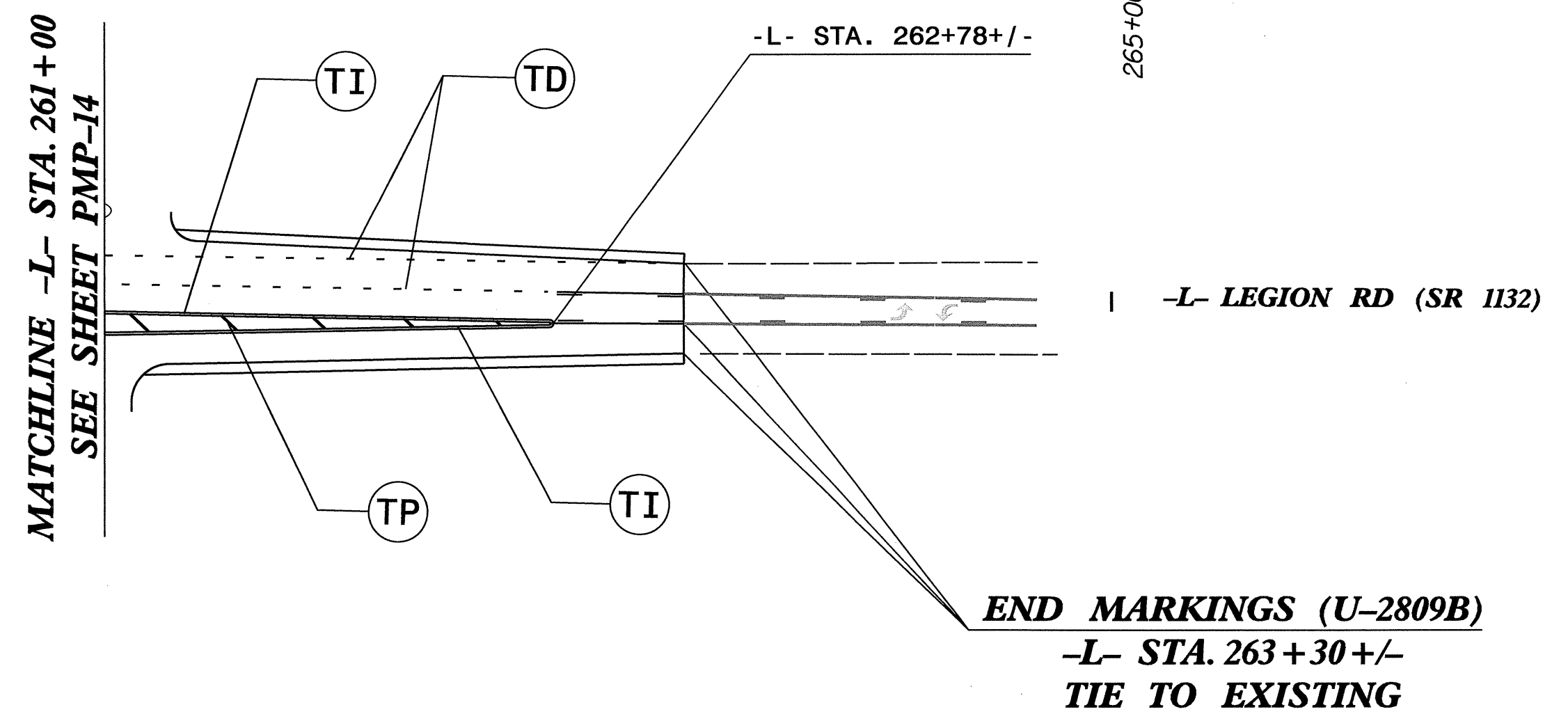

PAVEMENT MARKING DETAIL

18-MAY-2012 11:23
 P:\TIP\Projects-U\U2809B\Traffic\Signing\CADD\PMF\U-2809B\Sgn_PMP_Sheet+15.dgn
 br.ashid ATT:247739