

PROJECT SPECIAL PROVISION

(10-18-95)

Z-1

PERMITS

The Contractor's attention is directed to the following permits, which have been issued to the Department of Transportation by the authority granting the permit.

<u>PERMIT</u>	<u>AUTHORITY GRANTING THE PERMIT</u>
Dredge and Fill and/or Work in Navigable Waters (404)	U. S. Army Corps of Engineers
Water Quality (401)	Division of Environmental Management, DENR State of North Carolina
Buffer Certification	Division of Environmental Management, DENR State of North Carolina

The Contractor shall comply with all applicable permit conditions during construction of this project. Those conditions marked by * are the responsibility of the department and the Contractor has no responsibility in accomplishing those conditions.

Agents of the permitting authority will periodically inspect the project for adherence to the permits.

The Contractor's attention is also directed to Articles 107-10 and 107-13 of the *2012 Standard Specifications* and the following:

Should the Contractor propose to utilize construction methods (such as temporary structures or fill in waters and/or wetlands for haul roads, work platforms, cofferdams, etc.) not specifically identified in the permit (individual, general, or nationwide) authorizing the project it shall be the Contractor's responsibility to coordinate with the Engineer to determine what, if any, additional permit action is required. The Contractor shall also be responsible for initiating the request for the authorization of such construction method by the permitting agency. The request shall be submitted through the Engineer. The Contractor shall not utilize the construction method until it is approved by the permitting agency. The request normally takes approximately 60 days to process; however, no extensions of time or additional compensation will be granted for delays resulting from the Contractor's request for approval of construction methods not specifically identified in the permit.

Where construction moratoriums are contained in a permit condition which restricts the Contractor's activities to certain times of the year, those moratoriums will apply only to the portions of the work taking place in the waters or wetlands provided that activities outside those areas is done in such a manner as to not affect the waters or wetlands.



STATE OF NORTH CAROLINA
DEPARTMENT OF TRANSPORTATION

BEVERLY EAVES PERDUE
GOVERNOR

EUGENE A. CONTI, JR.
SECRETARY

June 29, 2012

To: File

From: Carla Dagnino, Environmental Supervisor

Subject: B-4752 Section 404 Permit by Default

The Section 404 General Permit for this project has been issued by default, per the U.S. Army Corps of Engineers. Therefore, NCDOT must comply with all conditions, descriptions, and mitigation allowance in the March 13, 2012 permit application (includes the Pre-Construction Notification Form and Permit Drawings), as well as the 404 Special Conditions and General Conditions. A permit modification will be required if any of the above conditions cannot be met.

MAILING ADDRESS:
NC DEPARTMENT OF TRANSPORTATION
PROJECT DEVELOPMENT AND ENVIRONMENTAL ANALYSIS
1598 MAIL SERVICE CENTER
RALEIGH NC 27699-1598

TELEPHONE: 919-717-6100
FAX: 919-212-5785
WEBSITE: WWW.DOH.DOT.STATE.NC.US

LOCATION:
1020 BIRCH RIDGE DRIVE
RALEIGH NC, 27610-4328

Dagnino, Carla S

From: Hair, Sarah E SAW <Sarah.E.Hair@usace.army.mil>
Sent: Thursday, June 14, 2012 11:24 AM
To: Dagnino, Carla S
Subject: RE: B-4752, Gaston County (UNCLASSIFIED)

Classification: UNCLASSIFIED
Caveats: NONE

Carla,

I would say that it is authorized by default. Please ensure NCDOT complies with all terms and conditions of the GP31.

Thank you,

Liz Hair
Project Manager
Asheville Regulatory Field Office
U.S Army Corps of Engineers-Wilmington District
151 Patton Ave, Room 208
Asheville, NC 28805
828-271-7980 x.225
sarah.e.hair@usace.army.mil

-----Original Message-----

From: Dagnino, Carla S [mailto:cdagnino@ncdot.gov]
Sent: Thursday, June 14, 2012 11:14 AM
To: Hair, Sarah E SAW
Subject: B-4752, Gaston County
Importance: High

Hi Liz,

This project has a review date coming up the first of July, so we are hoping to have the permit ready by the end of June.

The application was sent in March and you likely received it by the beginning of April. We received the 401 on April 30th.

Shall we go ahead and go with a permit by default, or do you plan on getting something to us soon?

Thanks.

Carla

Carla Dagnino

Project Management Group



Office Use Only:
Corps action ID no. _____
DWQ project no. _____
Form Version 1.3 Dec 10 2008

Pre-Construction Notification (PCN) Form		
A. Applicant Information		
1. Processing		
1a. Type(s) of approval sought from the Corps:	<input checked="" type="checkbox"/> Section 404 Permit	<input type="checkbox"/> Section 10 Permit
1b. Specify Nationwide Permit (NWP) number: _____ or General Permit (GP) number: 198200031		
1c. Has the NWP or GP number been verified by the Corps?		<input type="checkbox"/> Yes <input checked="" type="checkbox"/> No
1d. Type(s) of approval sought from the DWQ (check all that apply):		
<input checked="" type="checkbox"/> 401 Water Quality Certification – Regular <input type="checkbox"/> Non-404 Jurisdictional General Permit <input type="checkbox"/> 401 Water Quality Certification – Express <input checked="" type="checkbox"/> Riparian Buffer Authorization		
1e. Is this notification solely for the record because written approval is not required?	For the record only for DWQ 401 Certification: <input type="checkbox"/> Yes <input checked="" type="checkbox"/> No	For the record only for Corps Permit: <input type="checkbox"/> Yes <input checked="" type="checkbox"/> No
1f. Is payment into a mitigation bank or in-lieu fee program proposed for mitigation of impacts? If so, attach the acceptance letter from mitigation bank or in-lieu fee program.		<input checked="" type="checkbox"/> Yes <input type="checkbox"/> No
1g. Is the project located in any of NC's twenty coastal counties. If yes, answer 1h below.		<input type="checkbox"/> Yes <input checked="" type="checkbox"/> No
1h. Is the project located within a NC DCM Area of Environmental Concern (AEC)?		<input type="checkbox"/> Yes <input checked="" type="checkbox"/> No
2. Project Information		
2a. Name of project:	Replacement of Bridge No. 6 over the South Fork Catawba River on SR 2014 (North Main Street).	
2b. County:	Gaston	
2c. Nearest municipality / town:	Cramerton	
2d. Subdivision name:	<i>not applicable</i>	
2e. NCDOT only, T.I.P. or state project no:	B-4752	
3. Owner Information		
3a. Name(s) on Recorded Deed:	North Carolina Department of Transportation	
3b. Deed Book and Page No.	<i>not applicable</i>	
3c. Responsible Party (for LLC if applicable):	<i>not applicable</i>	
3d. Street address:	1598 Mail Service Center	
3e. City, state, zip:	Raleigh, NC 27699-1598	
3f. Telephone no.:	(919) 707-6124	
3g. Fax no.:	(919) 212-5785	
3h. Email address:	jwharrod@ncdot.gov	

4. Applicant Information (if different from owner)	
4a. Applicant is:	<input type="checkbox"/> Agent <input type="checkbox"/> Other, specify:
4b. Name:	<i>not applicable</i>
4c. Business name (if applicable):	
4d. Street address:	
4e. City, state, zip:	
4f. Telephone no.:	
4g. Fax no.:	
4h. Email address:	
5. Agent/Consultant Information (if applicable)	
5a. Name:	<i>not applicable</i>
5b. Business name (if applicable):	
5c. Street address:	
5d. City, state, zip:	
5e. Telephone no.:	
5f. Fax no.:	
5g. Email address:	

B. Project Information and Prior Project History	
1. Property Identification	
1a. Property identification no. (tax PIN or parcel ID):	<i>not applicable</i>
1b. Site coordinates (in decimal degrees):	Latitude: 35.23566 (DD.DDDDDD) Longitude: - 81.65465 (-DD.DDDDDD)
1c. Property size:	1.08 acres
2. Surface Waters	
2a. Name of nearest body of water (stream, river, etc.) to proposed project:	South Fork Catawba River
2b. Water Quality Classification of nearest receiving water:	South Fork Catawba River: WS-V
2c. River basin:	Catawba
3. Project Description	
3a. Describe the existing conditions on the site and the general land use in the vicinity of the project at the time of this application: Heavy urban development around the site; Vegetated riparian buffer along river and ponds identified as Piedmont Bottomland Forest.	
3b. List the total estimated acreage of all existing wetlands on the property: 0.09 ac	
3c. List the total estimated linear feet of all existing streams (intermittent and perennial) on the property: 86'	
3d. Explain the purpose of the proposed project: To replace a structurally deficient and functionally obsolete structure.	
3e. Describe the overall project in detail, including the type of equipment to be used: The project involves replacing one 420-foot six-span bridge with a 442-foot four-span bridge at existing location over the South Fork Catawba River. The bridge replacement will utilize an off-site detour. Standard road building equipment, such as trucks, dozers, and cranes will be used.	
4. Jurisdictional Determinations	
4a. Have jurisdictional wetland or stream determinations by the Corps or State been requested or obtained for this property / project (including all prior phases) in the past? Comments: A Jurisdictional Determination memo to Liz Hair and Polly Lespinasse, dated October 24, 2011, requested that a written JD be issued at permit time.	<input type="checkbox"/> Yes <input checked="" type="checkbox"/> No <input type="checkbox"/> Unknown
4b. If the Corps made the jurisdictional determination, what type of determination was made?	<input type="checkbox"/> Preliminary <input type="checkbox"/> Final
4c. If yes, who delineated the jurisdictional areas? Name (if known):	Agency/Consultant Company: Other:
4d. If yes, list the dates of the Corps jurisdictional determinations or State determinations and attach documentation.	
5. Project History	
5a. Have permits or certifications been requested or obtained for this project (including all prior phases) in the past?	<input type="checkbox"/> Yes <input checked="" type="checkbox"/> No <input type="checkbox"/> Unknown
5b. If yes, explain in detail according to "help file" instructions.	

6. Future Project Plans	
6a. Is this a phased project?	<input type="checkbox"/> Yes <input checked="" type="checkbox"/> No
6b. If yes, explain.	

C. Proposed Impacts Inventory						
1. Impacts Summary						
1a. Which sections were completed below for your project (check all that apply):						
<input checked="" type="checkbox"/> Wetlands <input checked="" type="checkbox"/> Streams - tributaries <input checked="" type="checkbox"/> Buffers <input checked="" type="checkbox"/> Open Waters <input type="checkbox"/> Pond Construction						
2. Wetland Impacts						
If there are wetland impacts proposed on the site, then complete this question for each wetland area impacted.						
2a. Wetland impact number – Permanent (P) or Temporary (T)	2b. Type of impact	2c. Type of wetland (if known)	2d. Forested	2e. Type of jurisdiction (Corps - 404, 10 DWQ – non-404, other)	2f. Area of impact (acres)	
Site 1 <input checked="" type="checkbox"/> P <input type="checkbox"/> T	Bridge & Approach	Bottomland Forest	<input checked="" type="checkbox"/> Yes <input type="checkbox"/> No	<input checked="" type="checkbox"/> Corps <input type="checkbox"/> DWQ	0.014	
Site 1 <input type="checkbox"/> P <input checked="" type="checkbox"/> T	Temporary Work Pad	Bottomland Forest	<input checked="" type="checkbox"/> Yes <input type="checkbox"/> No	<input checked="" type="checkbox"/> Corps <input type="checkbox"/> DWQ	0.013	
Site 1 <input type="checkbox"/> P <input type="checkbox"/> T			<input type="checkbox"/> Yes <input type="checkbox"/> No	<input type="checkbox"/> Corps <input type="checkbox"/> DWQ		
Site 2 <input type="checkbox"/> P <input type="checkbox"/> T			<input type="checkbox"/> Yes <input type="checkbox"/> No	<input type="checkbox"/> Corps <input type="checkbox"/> DWQ		
Site 3 <input type="checkbox"/> P <input type="checkbox"/> T			<input type="checkbox"/> Yes <input type="checkbox"/> No	<input type="checkbox"/> Corps <input type="checkbox"/> DWQ		
Site 4 <input type="checkbox"/> P <input type="checkbox"/> T			<input type="checkbox"/> Yes <input type="checkbox"/> No	<input type="checkbox"/> Corps <input type="checkbox"/> DWQ		
2g. Total wetland impacts					0.01 Permanent 0.01 Temporary	
2h. Comments: There will be 0.03 acre of hand clearing in wetlands; <0.01 acre of Temporary Fill in Wetlands in the Hand Clearing areas for erosion control measures.						
3. Stream Impacts						
If there are perennial or intermittent stream impacts (including temporary impacts) proposed on the site, then complete this question for all stream sites impacted.						
3a. Stream impact number - Permanent (P) or Temporary (T)	3b. Type of impact	3c. Stream name	3d. Perennial (PER) or intermittent (INT)?	3e. Type of jurisdiction (Corps - 404, 10 DWQ – non-404, other)	3f. Average stream width (feet)	3g. Impact length (linear feet)
Site 1 <input type="checkbox"/> P <input checked="" type="checkbox"/> T	Temporary Work Pad	South Fork Catawba River	<input checked="" type="checkbox"/> PER <input type="checkbox"/> INT	<input checked="" type="checkbox"/> Corps <input type="checkbox"/> DWQ	120-200	0.02 ac
Site 2 <input type="checkbox"/> P <input type="checkbox"/> T			<input type="checkbox"/> PER <input type="checkbox"/> INT	<input type="checkbox"/> Corps <input type="checkbox"/> DWQ		
Site 3 <input type="checkbox"/> P <input type="checkbox"/> T			<input type="checkbox"/> PER <input type="checkbox"/> INT	<input type="checkbox"/> Corps <input type="checkbox"/> DWQ		
Site 4 <input type="checkbox"/> P <input type="checkbox"/> T			<input type="checkbox"/> PER <input type="checkbox"/> INT	<input type="checkbox"/> Corps <input type="checkbox"/> DWQ		
Site 5 <input type="checkbox"/> P <input type="checkbox"/> T			<input type="checkbox"/> PER <input type="checkbox"/> INT	<input type="checkbox"/> Corps <input type="checkbox"/> DWQ		
Site 6 <input type="checkbox"/> P <input type="checkbox"/> T			<input type="checkbox"/> PER <input type="checkbox"/> INT	<input type="checkbox"/> Corps <input type="checkbox"/> DWQ		
3h. Total stream and tributary impacts					0 Perm 0.02 ac Temp	
3i. Comments:						

4. Open Water Impacts								
If there are proposed impacts to lakes, ponds, estuaries, tributaries, sounds, the Atlantic Ocean, or any other open water of the U.S. then individually list all open water impacts below.								
4a. Open water impact number – Permanent (P) or Temporary (T)	4b. Name of waterbody (if applicable)	4c. Type of impact			4d. Waterbody type	4e. Area of impact (acres)		
O1 <input checked="" type="checkbox"/> P <input type="checkbox"/> T		Bridge & Approach Fill			Pond	0.07		
O2 <input type="checkbox"/> P <input type="checkbox"/> T								
O3 <input type="checkbox"/> P <input type="checkbox"/> T								
O4 <input type="checkbox"/> P <input type="checkbox"/> T								
4f. Total open water impacts						0.07 Permanent 0 Temporary		
4g. Comments:								
5. Pond or Lake Construction								
If pond or lake construction proposed, then complete the chart below.								
5a. Pond ID number	5b. Proposed use or purpose of pond	5c. Wetland Impacts (acres)			5d. Stream Impacts (feet)			5e. Upland (acres)
		Flooded	Filled	Excavated	Flooded	Filled	Excavated	Flooded
P1								
P2								
5f. Total								
5g. Comments:								
5h. Is a dam high hazard permit required?				<input type="checkbox"/> Yes <input type="checkbox"/> No		If yes, permit ID no:		
5i. Expected pond surface area (acres):								
5j. Size of pond watershed (acres):								
5k. Method of construction:								

6. Buffer Impacts (for DWQ)						
If project will impact a protected riparian buffer, then complete the chart below. If yes, then individually list all buffer impacts below. If any impacts require mitigation, then you MUST fill out Section D of this form.						
6a. Project is in which protected basin?				<input type="checkbox"/> Neuse <input checked="" type="checkbox"/> Catawba	<input type="checkbox"/> Tar-Pamlico <input type="checkbox"/> Randleman	<input type="checkbox"/> Other:
6b. Buffer impact number – Permanent (P) or Temporary (T)	6c. Reason for impact	6d. Stream name	6e. Buffer mitigation required?	6f. Zone 1 impact (square feet)	6g. Zone 2 impact (square feet)	
B1 <input checked="" type="checkbox"/> P <input type="checkbox"/> T	Road Crossing	South Fork Catawba River	<input type="checkbox"/> Yes <input checked="" type="checkbox"/> No	35		
B1 <input checked="" type="checkbox"/> P <input type="checkbox"/> T	Bridge	South Fork Catawba River	<input type="checkbox"/> Yes <input checked="" type="checkbox"/> No	91		
B2 <input checked="" type="checkbox"/> P <input type="checkbox"/> T	Bridge	South Fork Catawba River	<input type="checkbox"/> Yes <input checked="" type="checkbox"/> No	28		
B2 <input checked="" type="checkbox"/> P <input type="checkbox"/> T	Bridge	South Fork Catawba River	<input type="checkbox"/> Yes <input checked="" type="checkbox"/> No	3167		
B3 <input checked="" type="checkbox"/> P <input type="checkbox"/> T	Road impacts other than crossings w/ surface waters	South Fork Catawba River	<input checked="" type="checkbox"/> Yes <input type="checkbox"/> No	1149	492	
6h. Total buffer impacts				4470	492	
6i. Comments: Although not on the mainstem Catawba River buffer rules apply to this project. Lake Wylie is fed by the Catawba River and the project site falls within the full pond elevation of Lake Wylie of 569 feet above mean sea level.						

D. Impact Justification and Mitigation		
1. Avoidance and Minimization		
1a. Specifically describe measures taken to avoid or minimize the proposed impacts in designing project. The replacement bridge for No. 6 is 22 feet longer than the existing bridge. Deck drains are absent therefore stormwater will not be directly discharged in the South Fork Catawba River. An off site detour will be used.		
1b. Specifically describe measures taken to avoid or minimize the proposed impacts through construction techniques. Standard construction techniques apply. Bridge No. 6 is constructed entirely of concrete and steel and should be possible to remove with no resulting debris in the water based on standard demolition practices.		
2. Compensatory Mitigation for Impacts to Waters of the U.S. or Waters of the State		
2a. Does the project require Compensatory Mitigation for impacts to Waters of the U.S. or Waters of the State?	<input checked="" type="checkbox"/> Yes <input type="checkbox"/> No If no, explain:	
2b. If yes, mitigation is required by (check all that apply):	<input checked="" type="checkbox"/> DWQ <input type="checkbox"/> Corps	
2c. If yes, which mitigation option will be used for this project?	<input type="checkbox"/> Mitigation bank <input checked="" type="checkbox"/> Payment to in-lieu fee program <input type="checkbox"/> Permittee Responsible Mitigation	
3. Complete if Using a Mitigation Bank		
3a. Name of Mitigation Bank: not applicable		
3b. Credits Purchased (attach receipt and letter)	Type	Quantity
3c. Comments:		
4. Complete if Making a Payment to In-lieu Fee Program		
4a. Approval letter from in-lieu fee program is attached.	<input checked="" type="checkbox"/> Yes	
4b. Stream mitigation requested:	0 linear feet	
4c. If using stream mitigation, stream temperature:	<input type="checkbox"/> warm <input type="checkbox"/> cool <input type="checkbox"/> cold	
4d. Buffer mitigation requested (DWQ only):	Zone 1 - 1149; Zone 2 - 492 square feet	
4e. Riparian wetland mitigation requested:	0.01 acres	
4f. Non-riparian wetland mitigation requested:	acres	
4g. Coastal (tidal) wetland mitigation requested:	acres	
4h. Comments:		
5. Complete if Using a Permittee Responsible Mitigation Plan		
5a. If using a permittee responsible mitigation plan, provide a description of the proposed mitigation plan.		

6. Buffer Mitigation (State Regulated Riparian Buffer Rules) – required by DWQ				
6a. Will the project result in an impact within a protected riparian buffer that requires buffer mitigation?				<input checked="" type="checkbox"/> Yes <input type="checkbox"/> No
6b. If yes, then identify the square feet of impact to each zone of the riparian buffer that requires mitigation. Calculate the amount of mitigation required.				
Zone	6c. Reason for impact	6d. Total impact (square feet)	Multiplier	6e. Required mitigation (square feet)
Zone 1	Road impacts other than crossings w/ surface waters	1149	3 (2 for Catawba)	2298
Zone 2	Road impacts other than crossings w/ surface waters	492	1.5	738
6f. Total buffer mitigation required:				3036
6g. If buffer mitigation is required, discuss what type of mitigation is proposed (e.g., payment to private mitigation bank, permittee responsible riparian buffer restoration, payment into an approved in-lieu fee fund). The Ecosystem Enhancement Program (EEP) will be providing buffer mitigation for this project.				
6h. Comments:				

E. Stormwater Management and Diffuse Flow Plan (required by DWQ)	
1. Diffuse Flow Plan	
1a. Does the project include or is it adjacent to protected riparian buffers identified within one of the NC Riparian Buffer Protection Rules?	<input checked="" type="checkbox"/> Yes <input type="checkbox"/> No
1b. If yes, then is a diffuse flow plan included? If no, explain why. Comments: see the Stormwater Management Plan attached.	<input checked="" type="checkbox"/> Yes <input type="checkbox"/> No
2. Stormwater Management Plan	
2a. What is the overall percent imperviousness of this project?	N/A
2b. Does this project require a Stormwater Management Plan?	<input checked="" type="checkbox"/> Yes <input type="checkbox"/> No
2c. If this project DOES NOT require a Stormwater Management Plan, explain why:	
2d. If this project DOES require a Stormwater Management Plan, then provide a brief, narrative description of the plan: see attached permit drawings	
2e. Who will be responsible for the review of the Stormwater Management Plan?	<input type="checkbox"/> Certified Local Government <input type="checkbox"/> DWQ Stormwater Program <input checked="" type="checkbox"/> DWQ 401 Unit
3. Certified Local Government Stormwater Review	
3a. In which local government's jurisdiction is this project?	not applicable
3b. Which of the following locally-implemented stormwater management programs apply (check all that apply):	<input type="checkbox"/> Phase II <input type="checkbox"/> NSW <input type="checkbox"/> USMP <input type="checkbox"/> Water Supply Watershed <input type="checkbox"/> Other:
3c. Has the approved Stormwater Management Plan with proof of approval been attached?	<input type="checkbox"/> Yes <input type="checkbox"/> No
4. DWQ Stormwater Program Review	
4a. Which of the following state-implemented stormwater management programs apply (check all that apply):	<input type="checkbox"/> Coastal counties <input type="checkbox"/> HQW <input type="checkbox"/> ORW <input type="checkbox"/> Session Law 2006-246 <input type="checkbox"/> Other:
4b. Has the approved Stormwater Management Plan with proof of approval been attached?	<input type="checkbox"/> Yes <input checked="" type="checkbox"/> No see attached permit drawings
5. DWQ 401 Unit Stormwater Review	
5a. Does the Stormwater Management Plan meet the appropriate requirements?	<input type="checkbox"/> Yes <input type="checkbox"/> No N/A
5b. Have all of the 401 Unit submittal requirements been met?	<input type="checkbox"/> Yes <input type="checkbox"/> No N/A

F. Supplementary Information	
1. Environmental Documentation (DWQ Requirement)	
1a. Does the project involve an expenditure of public (federal/state/local) funds or the use of public (federal/state) land?	<input checked="" type="checkbox"/> Yes <input type="checkbox"/> No
1b. If you answered "yes" to the above, does the project require preparation of an environmental document pursuant to the requirements of the National or State (North Carolina) Environmental Policy Act (NEPA/SEPA)?	<input checked="" type="checkbox"/> Yes <input type="checkbox"/> No
1c. If you answered "yes" to the above, has the document review been finalized by the State Clearing House? (If so, attach a copy of the NEPA or SEPA final approval letter.) Comments:	<input checked="" type="checkbox"/> Yes <input type="checkbox"/> No
2. Violations (DWQ Requirement)	
2a. Is the site in violation of DWQ Wetland Rules (15A NCAC 2H .0500), Isolated Wetland Rules (15A NCAC 2H .1300), DWQ Surface Water or Wetland Standards, or Riparian Buffer Rules (15A NCAC 2B .0200)?	<input type="checkbox"/> Yes <input checked="" type="checkbox"/> No
2b. Is this an after-the-fact permit application?	<input type="checkbox"/> Yes <input checked="" type="checkbox"/> No
2c. If you answered "yes" to one or both of the above questions, provide an explanation of the violation(s):	
3. Cumulative Impacts (DWQ Requirement)	
3a. Will this project (based on past and reasonably anticipated future impacts) result in additional development, which could impact nearby downstream water quality?	<input type="checkbox"/> Yes <input checked="" type="checkbox"/> No
3b. If you answered "yes" to the above, submit a qualitative or quantitative cumulative impact analysis in accordance with the most recent DWQ policy. If you answered "no," provide a short narrative description. Due to the minimal transportation impact resulting from this bridge replacement, this project will neither influence nearby land uses nor stimulate growth. Therefore, a detailed indirect or cumulative effects study will not be necessary.	
4. Sewage Disposal (DWQ Requirement)	
4a. Clearly detail the ultimate treatment methods and disposition (non-discharge or discharge) of wastewater generated from the proposed project, or available capacity of the subject facility. not applicable	

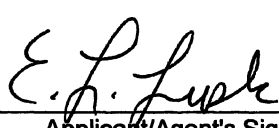
5. Endangered Species and Designated Critical Habitat (Corps Requirement)		
5a. Will this project occur in or near an area with federally protected species or habitat?	<input checked="" type="checkbox"/> Yes	<input type="checkbox"/> No
5b. Have you checked with the USFWS concerning Endangered Species Act impacts?	<input type="checkbox"/> Yes	<input checked="" type="checkbox"/> No
5c. If yes, indicate the USFWS Field Office you have contacted.	<input type="checkbox"/> Raleigh <input type="checkbox"/> Asheville	
5d. What data sources did you use to determine whether your site would impact Endangered Species or Designated Critical Habitat? USFWS T/E County Listings and habitat descriptions per the USFWS website; The only T/E species listed with habitat in the project study area is: Schweinitz's sunflower - last surveyed September 28, 2011 and has a biological conclusion of No Effect; No habitat is present for the Bog turtle		
6. Essential Fish Habitat (Corps Requirement)		
6a. Will this project occur in or near an area designated as essential fish habitat?	<input type="checkbox"/> Yes	<input checked="" type="checkbox"/> No
6b. What data sources did you use to determine whether your site would impact Essential Fish Habitat? NMFS County Index		
7. Historic or Prehistoric Cultural Resources (Corps Requirement)		
7a. Will this project occur in or near an area that the state, federal or tribal governments have designated as having historic or cultural preservation status (e.g., National Historic Trust designation or properties significant in North Carolina history and archaeology)?	<input type="checkbox"/> Yes	<input checked="" type="checkbox"/> No
7b. What data sources did you use to determine whether your site would impact historic or archeological resources? NEPA Documentation		
8. Flood Zone Designation (Corps Requirement)		
8a. Will this project occur in a FEMA-designated 100-year floodplain?	<input checked="" type="checkbox"/> Yes	<input type="checkbox"/> No
8b. If yes, explain how project meets FEMA requirements: NCDOT Hydraulics Unit coordination with FEMA		
8c. What source(s) did you use to make the floodplain determination? FEMA Maps		
Dr. Gregory J. Thorpe, Ph D Applicant/Agent's Printed Name	 Applicant/Agent's Signature (Agent's signature is valid only if an authorization letter from the applicant is provided.)	3.14.12 Date

DEPARTMENT OF THE ARMY
Wilmington District, Corps of Engineers
Post Office Box 1890
Wilmington, North Carolina 28402-1890

Regional General Permit No. 198200031
Name of Permittee: General Public
Effective Date: November 1, 2008
Expiration Date: October 31, 2013

**DEPARTMENT OF THE ARMY
REGIONAL GENERAL PERMIT**

A regional general permit (RGP) to perform work in or affecting navigable waters of the United States and waters of the United States, upon recommendation of the Chief of Engineers, pursuant to Section 10 of the Rivers and Harbors Act of March 3, 1899 (33 U.S.C. 403), and Section 404 of the Clean Water Act (33 U.S.C. 1344), is hereby modified and re-issued by authority of the Secretary of the Army by the

District Engineer
U.S. Army Engineer District, Wilmington
Corps of Engineers
Post Office Box 1890
Wilmington, North Carolina 28402-1890

TO AUTHORIZE THE DISCHARGE OF DREDGED OR FILL MATERIAL IN WATERS OF THE UNITED STATES, INCLUDING WETLANDS, ASSOCIATED WITH THE CONSTRUCTION, MAINTENANCE AND REPAIR OF BRIDGES, INCLUDING COFFERDAMS, ABUTMENTS, FOUNDATION SEALS, PIERS, APPROACH FILLS, DETOUR FILLS, BOX CULVERT INSTALLATION AND TEMPORARY CONSTRUCTION AND ACCESS FILLS, IN WATERS OF THE UNITED STATES AS PART OF WORK CONDUCTED BY THE NORTH CAROLINA DEPARTMENT OF TRANSPORTATION (NCDOT) OR OTHER STATE, FEDERAL OR LOCAL GOVERNMENTAL ENTITY, IN THE STATE OF NORTH CAROLINA.

1. Special Conditions.

a. Written confirmation that the proposed work complies with this RGP must be received from the Wilmington District Engineer prior to the commencement of any work. To enable this determination to be made, the permittee must furnish the Wilmington District Engineer a pre-construction notification with the following information:

(1) A map indicating the location of the work.

(2) Plans of the proposed work showing all pertinent structures, elevations, dimensions and quantities of materials and locations of all structures and/or fill in wetlands or waterward of the normal/high water elevation contours.

(3) A brief discussion of the affected aquatic resources, including streams and wetlands. The discussion shall include the identification and types of vegetation present.

(4) Approximate commencement and completion dates.

(5) A description of methods to be employed to avoid and/or minimize permanent and temporary impacts to aquatic resources caused by the proposed work.

(6) Plans, including timetables and techniques, for construction, stabilization and removal of all unavoidable temporary fills.

(7) Names and addresses of adjoining property owners.

b. In the case of fills of one acre or less, including permanent approach fills, detour fills and fills associated with culvert installation, the Corps of Engineers' Project Manager will determine, after appropriate onsite visits and review of plans, if the impacts on aquatic resources, including streams and wetlands, are likely to be such as to require review by Federal and State agencies. If it is determined that impacts are minimal or can be made minimal by changes agreed to by the applicant, a letter of authorization to proceed will be provided. If it is determined that review by Federal and State agencies is necessary to fully evaluate impacts, copies of all plans and materials will be forwarded to the U.S. Fish and Wildlife Service (USFWS), the National Marine Fisheries Service (NMFS), the U.S. Environmental Protection Agency (EPA) and the North Carolina Department of Environment and Natural Resources (NCDENR). These agencies will furnish comments to the Wilmington District Engineer within thirty (30) days.

c. In cases of fills greater than one acre, copies of all plans and materials will be forwarded to the USFWS, the NMFS, the EPA and the NCDENR. These agencies will furnish comments to the Wilmington District Engineer in thirty (30) days. In cases of land disturbing activities comprising more than one acre, a Sedimentation/Erosion Control Plan will be filed with the North Carolina Division of Land Resources, Land Quality Section, thirty (30) days prior to commencing work.

d. Where work is proposed within the twenty (20) coastal counties, as defined by the North Carolina Division of Coastal Management, the applicant shall forward a copy of the pre-construction notification to:

**National Marine Fisheries Service
101 Pivers Island Road**

Beaufort, North Carolina 28516

The counties in which this condition applies are:

Bertie	Carteret	Dare	Hyde	Pender
Beaufort	Chowan	Gates	Onslow	Perquimans
Brunswick	Craven	New Hanover	Pamlico	Tyrrell
Camden	Currituck	Hertford	Pasquotank	Washington

e. In the event that any Federal agency maintains an objection or any required State authorization is outstanding, no notice to proceed will be given until objections are resolved and State authorizations are issued.

f. No work will proceed until after the applicant has received written notice to proceed from the Wilmington District Engineer. This notice may include additional conditions and/or restrictions. Copies of the notice to proceed will be furnished to the USFWS, the NMFS, the EPA and the NCDENR with a brief description of the work, including the area of wetlands affected and the quantity of fill material.

g. Upon completion of any work authorized by this RGP, all temporary fills will be completely removed and the area reestablished as a wetland by restoring natural hydrology and native vegetation. Stream contours and riparian vegetation will be reestablished upon the removal of temporary culverts. In such instances, a restoration plan will be submitted to the Wilmington District Engineer for approval. Information in the restoration plan will be in accordance with special condition j. below.

h. Appropriate soil and erosion control measures must be established and maintained during construction. All fills, temporary and permanent, must be adequately stabilized at the earliest practicable date to prevent erosion of fill material into adjacent waters or wetlands.

i. In cases where new alignment approaches are to be constructed and the existing wetland approach fill is to be abandoned and no longer to be maintained as a roadway, the abandoned fill shall be removed and the area reestablished as a wetland. In such instances, a restoration plan will be submitted to the Wilmington District Engineer for approval. Information in the restoration plan will be in accordance with special condition j. below.

j. Discharges of dredged or fill material into waters of the United States, including wetlands, must be minimized or avoided to the maximum extent practicable. In reviewing an activity, the Wilmington District Engineer will first determine whether the activity will result in more than minimal adverse environmental affects. For activities that are determined to have more than minimal impacts, compensatory mitigation will be required. To expedite the process, the applicant will provide a mitigation plan with the request for authorization. Site specific mitigation proposals will include, but are not necessarily limited to, a description of work, a schedule of work and a monitoring plan, and they will be in accordance with currently approved

Wilmington District and/or Corps-wide mitigation guidelines. The applicant may propose other forms of mitigation, such as mitigation bank credits or in-lieu fee mitigation with the notification, which in some situations and at the discretion of the Wilmington District, may be considered acceptable mitigation.

k. Activities in any North Carolina designated "Mountain Trout Waters" must comply with all pH, temperature and turbidity criteria established for such waters by the North Carolina Wildlife Resources Commission (NCWRC) and/or the North Carolina Division of Water Quality (NCDWQ). Work that may result in the sedimentation of trout waters will generally be prohibited from October 15 to April 15, of any year, to avoid impacts on trout spawning.

l. Before discharging dredged or fill material into waters of the United States, including wetlands, in the twenty-five (25) mountain counties of North Carolina that contain trout waters, the applicant will obtain and provide a letter of comments and recommendations from the NCWRC on the proposed activities. A discussion of alternatives to working in the mountain trout waters and why alternatives were not selected, and a plan to provide compensatory mitigation for all unavoidable adverse impacts to the mountain trout waters shall also be submitted with the letter from NCWRC. To facilitate coordination with the NCWRC, the proponent may provide a copy of the notification to the NCWRC concurrent with the notification to the District Engineer. The NCWRC will respond both to the proponent and directly to the Corps of Engineers.

The applicant should contact NCWRC in the following NC Trout Counties at:

Mr. Ron Linville Western Piedmont Region Coordinator 3855 Idlewild Road Kernersville, NC 27284-9180 Telephone: (336) 769-9453	Counties		
	Alleghany	Caldwell	Watauga
	Ashe	Mitchell	Wilkes
	Avery	Stokes	
	Burke	Surry	

Mr. Dave McHenry Mountain Region Coordinator 20830 Great Smoky Mtn. Expressway Waynesville, NC 28786 Telephone: (828) 452-2546 Fax: (828) 452-7772	Counties		
	Buncombe	Henderson	Polk
	Cherokee	Jackson	Rutherford
	Clay	Macon	Swain
	Graham	Madison	Transylvania
	Haywood	McDowell	Yancey

m. This permit does not authorize the use of culverts in areas designated as anadromous fish spawning areas by the North Carolina Division of Marine Fisheries (NCDMF) or the North Carolina Wildlife Resources Commission (NCWRC).

n. Discharges into Waters of the United States designated by either the North Carolina Division of Marine Fisheries (NCDMF) or the NCWRC as anadromous fish spawning area are prohibited during the period between February 15 and June 30, without prior written approval from NCDMF or NCWRC and the Corps. Discharges into waters of the United States designated by NCDMF as primary nursery areas and discharges into waters of the United States designated by NCWRC as inland nursery areas shall be coordinated with NCDMF and NCWRC prior to being authorized by this RGP. Coordination with NCDMF and NCWRC may result in a required construction moratorium during periods of significant biological productivity or critical life stages.

The Applicant should contact:

NC Division of Marine Fisheries
3441 Arendell Street
Morehead City, NC 28557
Telephone 252-726-7021
or 800-682-2632

North Carolina Wildlife Resources Commission
Habitat Conservation Program Manager
1721 Mail Service Center
Raleigh, NC 27699-1721
Telephone (919) 733-7638

o. No activity may result in substantial permanent disruption of the movement of those species of aquatic life indigenous to the waterbody, including those species that normally migrate through the area. The dimension, pattern, and profile of the stream above and below a pipe or culvert should not be modified by widening the stream channel or by reducing the depth of the stream in connection with the construction activity. The width, height, and gradient of a proposed opening should be such as to pass the average historical low flow and spring flow without adversely altering flow velocity. Spring flow should be determined from gage data, if available. In the absence of such data, bankfull flow can be used as a comparable level.

p. This permit generally allows the permanent installation of culverts to 100 feet in length. For culverts longer than 100 feet, the proposed application will be closely evaluated to determine if unacceptable impacts on movement of aquatic organisms would result. In such cases, approval may not be provided.

q. If the project is located within the twenty (20) counties of North Carolina designated as coastal counties by the Coastal Area Management Act (CAMA), then all pipe and culvert inverts will be buried at least one foot below normal bed elevation when they are placed within the Public Trust Area of Environmental Concern (AEC) and/or the Estuarine Waters AEC as designated by CAMA, and/or all streams appearing as blue lines on United States Geological Survey (USGS) quad sheets. If the project is not located within the twenty (20) counties of North Carolina designated as coastal counties by CAMA, then culvert inverts will be buried at least one foot below the bed of the stream for culverts greater than 48 inches in diameter. Culverts 48 inches in diameter or less shall be buried or placed on the stream bed as practicable and appropriate to maintain aquatic passage, and every effort shall be made to maintain the existing channel slope. The potential for destabilization of the channel and head cutting upstream should

be considered in the placement of the culvert. A waiver from the depth specifications in this condition may be requested in writing. The waiver will only be issued if it can be demonstrated that the impacts of complying with this condition would result in more adverse impacts to the aquatic environment. Culverts placed in wetlands do not have to be buried.

r. All activities authorized by this RGP shall, to the extent practicable, be conducted "in the dry", with barriers installed between work areas and aquatic habitat to protect that habitat from cement or other pollutants. Where concrete is utilized, measures will be taken to prevent live or fresh concrete, including bags of uncured concrete, from coming into contact with waters of the state until the concrete has hardened. Water in the work area will be pumped to holding and settling ponds as practicable, and water will not be allowed to re-enter the water column until decanted.

s. If the project authorized by this RGP is proposed by a Federal or State agency, and is located within the twenty (20) counties of North Carolina designated as coastal counties by the CAMA, then prior to project initiation the proponent must obtain a consistency concurrence that the proposed project would be consistent with the state's coastal management program from the N.C. Division of Coastal Management (DCM). A copy of the state's consistency approval must be provided to the appropriate Wilmington District Regulatory Office at the following address:

Wilmington Regulatory Field Office
P.O. Box 1890
Wilmington, NC 28402

Washington Regulatory Field Office
P.O. Box 1000
Washington, NC 27889

The state's consistency approval will be conveyed in the form of a CAMA permit if the project is located within a designated CAMA Area of Environmental Concern (AEC), and will be conveyed in the form of a Consistency concurrence letter from DCM if the project is not located within a designated CAMA AEC.

t. No work shall be authorized by the RGP within the twenty coastal counties, as defined by the North Carolina Division of Coastal Management, without prior consultation with NOAA Fisheries. For each activity reviewed by the Corps of Engineers where it is determined that the activity may affect Essential Fish Habitat (EFH) for Federally managed species, an EFH Assessment shall be prepared by the applicant and forwarded to the Corps of Engineers and NOAA Fisheries for review and comment prior to authorization of work.

u. All work will comply with Water Quality Certification No. 3404, issued by the NCDWQ on 30 September 2008.

v. The activity must be designed to maintain preconstruction downstream flow conditions (e.g., location, capacity, and flow rates). Furthermore, the activity must not permanently restrict or impede the passage of normal or expected high flows and the structure or discharge of dredged or fill material must withstand expected high flows

2. General Conditions.

a. All activities authorized by this RGP that involve the discharge of dredged or fill material in waters of the United States will be consistent with applicable water quality standards, effluent limitations and standards of performance, prohibitions, pre-treatment standards and management practices established pursuant to the Clean Water Act (33 U.S.C. 1344) and applicable State and local law. If the proposed activity involves the discharge of dredged or fill material in waters of the United States, prior to the commencement of any work, the applicant will satisfy the NCDWQ regarding the need for a Water Quality Certification pursuant to Section 401 of the Clean Water Act.

b. All activities authorized by this RGP that involve the use of concrete as a building material, measures will be taken to prevent live or fresh concrete, including bags of uncured concrete, from coming into contact with waters of the state until the concrete has hardened.

c. To the maximum extent practicable, the pre-construction course, condition, capacity, and location of open waters must be maintained for each activity, including stream channelization and storm water management activities, except as provided below. The activity must be constructed to withstand expected high flows. The activity must not restrict or impede the passage of normal or high flows. The activity may alter the pre-construction course, condition, capacity, and location of open waters if it benefits the aquatic environment (e.g., stream restoration or relocation activities).

d. All activities authorized by this RGP that involve the use of riprap material for bank stabilization, the following measures shall be applied:

(1) Filter cloth must be placed underneath the riprap as an additional requirement of its use in North Carolina waters.

(2) The placement of riprap shall be limited to the areas depicted on submitted work plan drawings.

(3) The riprap material shall be clean and free from loose dirt or any pollutant except in trace quantities that would not have an adverse environmental effect.

(4) It shall be of a size sufficient to prevent its movement from the authorized alignment by natural forces under normal conditions.

(5) The riprap material shall consist of clean rock or masonry material such as, but not limited to, granite, marl, or broken concrete.

(6) A waiver from the specifications in this general condition may be requested in writing. The waiver will only be issued if it can be demonstrated that the impacts of complying with this Regional condition would result in greater adverse impacts to the aquatic environment.

- e. There will be no unreasonable interference with navigation or the right of the public to riparian access by the existence or use of activities authorized by this RGP.
- f. The activity must comply with applicable FEMA approved state or local floodplain management requirements.
- g. Heavy equipment working in wetlands or mudflats must be placed on mats, or other measures must be taken to minimize soil disturbance.
- h. A permittee, upon receipt of written notice from the Wilmington District Engineer of failure to comply with the terms or conditions of this RGP, will, within 60 days, without expense to the U.S. Government, and in such manner as the Wilmington District Engineer may direct, affect compliance with the terms and conditions or return the worksite to a pre-work condition.
- i. The permittee must make every reasonable effort to perform the work authorized herein in a manner so as to minimize any adverse impact on fish, wildlife and natural environmental values.
- j. The permittee must perform the work authorized herein in a manner so as to minimize any degradation of water quality. The activity will be conducted in such a manner as to prevent a significant increase in turbidity outside the area of construction or construction-related discharge. Increases such that the turbidity in the water body is 50 NTU's or less in all rivers not designated as trout waters by the North Carolina Division of Environmental Management (NCDEM), 25 NTU's or less in all saltwater classes and in all lakes and reservoirs, and 10 NTU's or less in trout waters, are not considered significant.
- k. The permittee will permit the Wilmington District Engineer or his representative to make periodic inspections at any time deemed necessary in order to assure that the activity is being performed or maintained in strict accordance with the Special and General Conditions of this permit.
- l. This RGP does not convey any rights, either in real estate or material, or any exclusive privileges; and it does not authorize any injury to property or invasion of rights or any infringement of Federal, State or local laws or regulations, nor does it obviate the requirement to obtain State or local assent required by law for the activity authorized herein. These may include, but are not necessarily limited to, a Dredge and/or Fill Permit (N.C.G.S. 113-229), a CAMA Permit (N.C.G.S. 113A-118), an Easement to Fill (N.C.G.S. 146-12) and a Water Quality Certification pursuant to Section 401 of the Clean Water Act.
- m. Authorization provided by this RGP may be modified, suspended or revoked in whole or in part if the Wilmington District Engineer, acting on behalf of the Secretary of the Army, determines that such action would be in the best public interest. Unless subject to modification, suspension or revocation, the term of this RGP shall be five years. Any modification, suspension or revocation of this authorization will not be the basis for any claim for damages against the U.S. Government.

n. This RGP does not authorize the interference with any existing or proposed Federal project and the permittee will not be entitled to compensation for damages or injury to the structures or work authorized herein which may be caused by or results from existing or future operations undertaken by the United States in the public interest.

o. This RGP will not be applicable to proposed construction when the Wilmington District Engineer determines that the proposed activity would significantly affect the quality of the human environment and determines that an Environmental Impact Statement (EIS) must be prepared.

p. This RGP will not be applicable to proposed construction when the Wilmington District Engineer determines, after any necessary investigations, that the proposed activity would adversely affect areas that possess historic, cultural, scenic, conservation or recreational values. Application of this exemption applies to:

(1) Rivers named in Section 3 of the Wild and Scenic Rivers Act (15 U.S.C. 1273), those proposed for inclusion as provided by Sections 4 and 5 of the Act and wild, scenic and recreational rivers established by State and local entities.

(2) Historic, cultural or archeological sites listed in or eligible for inclusion in the National Register of Historic Places as defined in the National Historic Preservation Act of 1966 as amended, the Abandoned Shipwreck Act of 1987 and the Native American Graves Protection and Repatriation Act.

(3) Sites included in or determined eligible for listing in the National Registry of Natural Landmarks.

(4) Endangered or threatened species or habitat of such species as determined by the Secretaries of Interior or Commerce and concerned in accordance with the Endangered Species Act (16 U.S.C. 1531).

(5) NOAA designated marine sanctuaries, National Estuarine Research Reserves, and coral reefs.

q. Permittees are advised that activities in or near a floodway may be subject to the National Flood Insurance Program, which prohibits any activities, including fill within a floodway that results in any increase in base flood elevations.

r. At his discretion, the Wilmington District Engineer may determine that this RGP will not be applicable to a specific construction proposal. In such case, the procedure for processing an individual permit in accordance with 33 CFR 325 will be available.

s. Any authorized structure or fill shall be properly maintained, including maintenance to ensure public safety.

t. The discharge of dredged or fill material shall consist of suitable material free from toxic pollutants in toxic amounts.

BY AUTHORITY OF THE SECRETARY OF THE ARMY:



Jefferson M. Ryscavage.
Colonel, Corps of Engineers
District Commander

RECEIVED
 APR 30 2012
 DIVISION OF HIGHWAYS
 DEPARTMENT OF ENVIRONMENT AND NATURAL RESOURCES
 Beverly Eaves Perdue
 Governor



North Carolina Department of Environment and Natural Resources

Division of Water Quality
 Charles Wakild
 Director

Dee Freeman
 Secretary

April 26, 2012
 DWQ #12-0313
 Gaston County

Dr. Gregory J. Thorpe, PhD., Manager
 Project Development and Environmental Analysis
 North Carolina Department of Transportation
 1598 Mail Service Center
 Raleigh, North Carolina, 27699-1598

SUBJECT: Approval of 401 Water Quality Certification and Riparian Buffer Authorization with Additional Conditions for the Proposed Replacement of Bridge No. 6 over the South Fork Catawba River on State Road (SR) 2014 (North Main Street), Federal Aid Project No. BRSTP-2014(3), TIP No. B-4752, WBS 38524.1.1, Gaston County

Dear Dr. Thorpe:

You have our approval, in accordance with the attached conditions and those listed below, to **permanently impact a total of 0.01 acres of wetlands, 0.07 acres of open water, and 4,962 square feet of buffers, and to temporarily impact 0.04 acres of wetlands, and 0.02 acres of streams (approximately 60 linear feet)** as listed in the table below:

Wetland Impacts in the Catawba River Basin

Permit Site Number	Permanent Fill (acres)	Temporary Fill (acres)	Excavation (acres)	Mechanized Clearing (acres)	Hand Clearing (acres)	Total Wetland Impact (acres)	Wetland Impacts Requiring Mitigation (acres)
Site #1	0.01	0.01			0.03	0.05	0

Total Wetland Impacts for the Project: 0.05 acres

Open Water Impacts in the Catawba River Basin

Permit Site Number	Permanent Fill in Open Waters (acres)	Temporary Fill in Open Waters (acres)	Total Fill in Open Waters (acres)
Site #1	0.07		0.07

Total Open Water Impacts for the Project: 0.07 acres

Total Stream Impacts in the Catawba River Basin

Permit Site Number	Permanent Fill in Intermittent Stream (linear feet)	Temporary Fill in Intermittent Stream (linear feet)	Permanent Fill in Perennial Stream (linear feet)	Temporary Fill in Perennial Stream (linear feet)	Total Stream Impact (linear feet)	Stream Impact Requiring Mitigation (linear feet)
Site #1				~60 linear feet (0.02 acres)		0

Total Stream Impacts for the Project: 60 linear feet

Dr. Gregory Thorpe
Page Two

Riparian Buffer Impacts in the Catawba River Basin

Permit Site Number	Zone 1 Impacts in square feet (sq ft)/Type of Impact	Zone 1 Buffer Mitigation Required Length of Impact (using 2:1 ratio)	Zone 2 Impacts in square feet (sq ft)	Zone 2 Buffer Mitigation Required Length of Impact (using 1.5:1 ratio)
Site #1	126 sq. ft. of permanent impact (35 sq. ft. for roadway approach and 91 sq. ft. for bridge)	0	0	0
Site #2	322 sq. ft. of permanent impact (28 sq. ft. for bridge pier, 194 sq. ft. for bridge), 2,973 sq. ft. of temporary impact for temporary work pad	0	0	0
Site #3	1,149 sq. ft. of permanent impact for road fill	2,298 sq. ft.	492 sq. ft. of permanent impact for road fill	738 sq. ft.

Total Buffer Impact for Project: 5,062 square feet

The above impacts reflect those described in your application received by the Division of Water Quality (DWQ) on March 27, 2012. After reviewing your application, we have determined that this project is covered by Water Quality General Certification Numbers 3820. This approval is also valid for the Catawba Riparian Buffer Rules 15A NCAC 2B0.243. Please note that you should get any other federal, state or local permits before proceeding with your project, including those required by (but not limited to) Sediment and Erosion Control, Non-Discharge, and Water Supply Watershed regulations. This approval will expire with the associated 404 permit unless otherwise specified in the Water Quality Certification.

1. The outside buffer, wetland or water boundary located within the construction corridor approved by this certification shall be clearly marked by highly visible fencing prior to any land disturbing activities. Impacts to areas within the fencing are prohibited unless otherwise authorized by this certification.
2. **All stormwater runoff shall be directed as sheetflow through stream buffers at non-erosive velocities, unless otherwise approved by this certification.**
3. All riparian buffers impacted by the placement of temporary fill or clearing activities shall be restored to the preconstruction contours and revegetated. Maintained buffers shall be permanently revegetated with non-woody species by the end of the growing season following completion of construction. For the purpose of this condition, maintained buffers are defined as areas within the transportation corridor that will be subject to regular NCDOT maintenance activities, including mowing. The area with non-maintained buffers shall be permanently revegetated with native woody species before the next growing season following completion of construction.
4. Pursuant to 15A NCAC 2B.0243(6), sediment and erosion control devices shall not be placed in Zone 1 of any Catawba Buffer without prior approval by NCDWQ. At this time, NCDWQ has approved no sediment and erosion control devices in Zone 1, outside of the approved project impacts, anywhere on this project. Moreover, sediment and erosion control devices shall be allowed in Zone 2 of the buffers provided that Zone 1 is not compromised and that discharge is released as diffuse flow.
5. **All portions of the proposed project draining to 303(d) listed watersheds that are impaired due to turbidity shall be designed, constructed, and operated with sediment and erosion control measures that meet Design Standards in Sensitive Watersheds [15A NCAC 4B .0124]. However, due to the size of the project, NC DOT shall not be required to meet 15A NCAC 4B .0124(a) regarding the maximum amount of uncovered acres.**
6. Turbidity curtains shall be used to isolate all work areas from the stream, including pile or casement installation, placement of riprap, excavation or filling. Strict adherence to the Construction and Maintenance Best Management Practices will be required.

Dr. Gregory Thorpe
Page Three

7. The post-construction removal of any temporary bridge structures must return the project site to its preconstruction contours and elevations. The impacted areas shall be revegetated with appropriate native species.
8. Strict adherence to the most recent version of NCDOT's Best Management Practices For Bridge Demolition and Removal approved by the US Army Corps of Engineers is a condition of the 401 Water Quality Certification.
9. Bridge deck drains shall not discharge directly into the stream. Stormwater shall be directed across the bridge and pre-treated through site-appropriate means (grassed swales, pre-formed scour holes, vegetated buffers, etc.) before entering the stream. Please refer to the most current version of *Stormwater Best Management Practices*.
10. Bridge piles and bents shall be constructed using driven piles (hammer or vibratory) or drilled shaft construction methods. More specifically, jetting or other methods of pile driving are prohibited without prior written approval from NCDWQ first.
11. No drill slurry or water that has been in contact with uncured concrete shall be allowed to enter surface waters. This water shall be captured, treated, and disposed of properly.
12. All pile driving or drilling activities shall be enclosed in turbidity curtains unless otherwise approved by NCDWQ in this certification.
13. All bridge construction shall be performed from the existing bridge, temporary work bridges, temporary causeways, or floating or sunken barges. If work conditions require barges, they shall be floated into position and then sunk. The barges shall not be sunk and then dragged into position. Under no circumstances should barges be dragged along the bottom of the surface water.
14. The dimension, pattern and profile of the stream above and below the crossing shall not be modified. Disturbed floodplains and streams shall be restored to natural geomorphic conditions.
15. If concrete is used during construction, a dry work area shall be maintained to prevent direct contact between curing concrete and stream water. Water that inadvertently contacts uncured concrete shall not be discharged to surface waters due to the potential for elevated pH and possible aquatic life and fish kills.
16. During the construction of the project, no staging of equipment of any kind is permitted in waters of the U.S. or protected riparian buffers.
17. The use of riprap above the normal high water mark shall be minimized. Any riprap placed for stream stabilization shall be placed in stream channels in such a manner that it does not impede aquatic life passage.
18. Heavy equipment shall be operated from the banks rather than in the stream channel in order minimize sedimentation and reduce the introduction of other pollutants into the stream.
19. No rock, sand or other materials shall be dredged from the stream channel except where authorized by this certification.
20. Temporary dewatering sites must be restored to pre-existing conditions unless more natural geomorphic conditions can be provided.
21. If concrete is used during construction, a dry work area should be maintained to prevent direct contact between curing concrete and stream water. Water that inadvertently contacts uncured concrete should not be discharged to surface waters due to the potential for elevated pH and possible aquatic life and fish kills.
22. All work in or adjacent to stream waters shall be conducted in a dry work area. Approved BMP measures from the most current version of the NCDOT Construction and Maintenance Activities manual such as sandbags, rock berms, cofferdams and other diversion structures shall be used to prevent excavation in flowing water.

Dr. Gregory Thorpe
Page Four

23. All mechanized equipment operated near surface waters must be regularly inspected and maintained to prevent contamination of stream waters from fuels, lubricants, hydraulic fluids, or other toxic materials.
24. All fill slopes located in jurisdictional wetlands shall be placed at slopes no flatter than 3:1, unless otherwise authorized by this certification.
25. Discharging hydroseed mixtures and washing out hydroseeders and other equipment in or adjacent to surface waters is prohibited.
26. A copy of this Water Quality Certification shall be posted on the construction site at all times. In addition, the Water Quality Certification and all subsequent modifications, if any, shall be maintained with the Division Engineer and the on-site project manager.
27. Native riparian vegetation must be re-established within the construction limits of the project by the end of the growing season following completion of construction.
28. Sediment and erosion control measures shall not be placed in wetlands or waters to the maximum extent practicable. If placement of sediment and erosion control devices in wetlands and waters is unavoidable, they shall be removed and the natural grade restored within 30 days after the Division of Land Resources has released the project.
29. Erosion and sediment control practices must be in full compliance with all specifications governing the proper design, installation and operation and maintenance of such Best Management Practices in order to protect surface waters standards:
 - a. The erosion and sediment control measures for the project must be designed, installed, operated, and maintained in accordance with the most recent version of the *North Carolina Sediment and Erosion Control Planning and Design Manual*.
 - b. The design, installation, operation, and maintenance of the sediment and erosion control measures must be such that they equal, or exceed, the requirements specified in the most recent version of the *North Carolina Sediment and Erosion Control Manual*. The devices shall be maintained on all construction sites, borrow sites, and waste pile (spoil) projects, including contractor-owned or leased borrow pits associated with the project.
 - c. For borrow pit sites, the erosion and sediment control measures must be designed, installed, operated, and maintained in accordance with the most recent version of the *North Carolina Surface Mining Manual*.
 - d. The reclamation measures and implementation must comply with the reclamation in accordance with the requirements of the Sedimentation Pollution Control Act.
30. The North Carolina Department of Transportation (NCDOT) and its contractors and/or agents shall not excavate, fill or perform mechanized land clearing at any time in the construction or maintenance of this project within waters and/or wetlands, except as authorized by this Certification, or any modification to this Certification (e.g., no work shall occur outside of the footprint of the plans provided). In addition, there shall be no excavation from or waste disposal into jurisdictional wetlands or waters associated with this Certification without appropriate modification. If this occurs, compensatory mitigation may be required since it is a direct impact from road construction activities.
- * 31. The Permittee shall ensure that the final design drawings adhere to the certification and to the drawings submitted for approval.
32. The Permittee shall report any violations of this certification to the Division of Water Quality within 24 hours of discovery.
- * 33. Upon completion of the project, the NCDOT Division Engineer shall complete and return the enclosed "Certificate of Completion" form to notify DWQ when all work included in the 401 Certification has been completed. Please include photographs upstream and downstream of the structure to document correct installation.

Dr. Gregory Thorpe
Page Five

34. **Continuing Compliance.** NCDOT shall conduct its activities in a manner so as not to contravene any state water quality standard [including any requirements for compliance with section 303(d) of the Clean Water Act] and any other appropriate requirements of state and federal law. If DWQ determines that such standards or laws are not being met (including the failure to sustain a designated or achieved use) or that state or federal law is being violated, or that further conditions are necessary to assure compliance, DWQ may reevaluate and modify this certification to include conditions appropriate to assure compliance with such standards and requirements in accordance with 15 A NCAC 2H.0507(d). Before codifying the certification, DWQ shall notify NCDOT and the USACE, provide public notice in accordance with 15A NCAC 2H.0503, and provide opportunity for public hearing in accordance with 15A NCAC 2H.0504. Any new or revised conditions shall be provided to NCDOT in writing, shall be provided to the USACE for reference in any permit issued pursuant to Section 404 of the Clean Water Act, and shall also become conditions of the 404 Permit for the project.

If you do not accept any of the conditions of this Certification, you may ask for an adjudicatory hearing. You must act within 60 days of the date that you receive this letter. To ask for a hearing, send a written petition that conforms to Chapter 150B of the North Carolina General Statutes to the Office of Administrative Hearings, 6714 Mail Service Center, Raleigh, N.C. 27699-6714. This Certification and its conditions are final and binding unless you ask for a hearing.

This letter completes the review by the Division of Water Quality under Section 401 of the Clean Water Act. If you have any questions, please telephone Polly Lespinasse in the Mooresville Regional Office at 704-663-1699.

Sincerely,

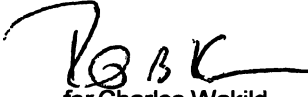

for Charles Wakild

Attachments

cc: Liz Hair, USACE Asheville Field Office
Sonia Carrillo, DWQ Wetlands Unit
File Copy

Water Quality Certification N^o. 3820

GENERAL CERTIFICATION FOR PROJECTS ELIGIBLE FOR U.S. ARMY CORPS OF ENGINEERS NATIONWIDE PERMIT NUMBER 14 (LINEAR TRANSPORTATION PROJECTS) AND REGIONAL GENERAL PERMIT 198200031 (WORK ASSOCIATED WITH BRIDGE CONSTRUCTION, MAINTENANCE OR REPAIR CONDUCTED BY NCDOT OR OTHER GOVERNMENT AGENCIES) AND RIPARIAN AREA PROTECTION RULES (BUFFER RULES)

Water Quality Certification Number 3820 is issued in conformity with the requirements of Section 401, Public Laws 92-500 and 95-217 of the United States and subject to the North Carolina Division of Water Quality (DWQ) Regulations in 15A NCAC 2H, Section .0500 and 15A NCAC 2B .0200 for the discharge of fill material to waters and adjacent wetland areas or to wetland areas that are not a part of the surface tributary system to interstate waters or navigable waters of the United States (as described in 33 CFR 330 Appendix A (B) (14) of the Corps of Engineers regulations (Nationwide Permit No. 14 and Regional General Permit 198200031) and for the Riparian Area Protection Rules (Buffer Rules) in 15A NCAC 2B .0200.

The State of North Carolina certifies that the specified category of activity will not violate applicable portions of Sections 301, 302, 303, 306 and 307 of the Public Laws 92-500 and 95-217 if conducted in accordance with the conditions hereinafter set forth.

- * Any proposed fill or modification of wetlands and/or waters, including streams, under this General Certification requires application to, and written approval from the Division of Water Quality (the "Division") except for the single family lot exemption described below.

Application and written approval is *not* required for construction of a driveway to a single family lot as long as the driveway involves *less than 25 feet* of temporary and/or permanent stream channel impacts, including any in-stream stabilization needed for the crossing. This activity must meet all of the Conditions of Certification listed below. **If any of these Conditions cannot be met, or if the activity is associated with or in response to a Notice of Violation from the Division of Water Quality or the NC Division of Land Resources, then written approval from the Division is required.**

- * In accordance with North Carolina General Statute Section 143-215.3D(e), written approval for a 401 Water Quality General Certification must include the appropriate fee. If a project also requires a CAMA Permit, one payment to both agencies shall be submitted and will be the higher of the two fees.

Conditions of Certification:

1. No Impacts Beyond those Authorized in the Written Approval or Beyond the Threshold for Use of this Certification

No waste, spoil, solids, or fill of any kind shall occur in wetlands, waters, or riparian areas beyond the footprint of the impacts authorized in the written approval or beyond the thresholds for use of this Certification, including incidental impacts. All construction activities, including the design, installation, operation, and maintenance of sediment and erosion control Best Management Practices, shall be performed so that no violations of state water quality standards, statutes, or rules occur.

2. Standard Erosion and Sediment Control Practices

Erosion and sediment control practices must be in full compliance with all specifications governing the proper design, installation and operation and maintenance of such Best Management Practices:

Water Quality Certification N^o. 3820

- a. Design, installation, operation, and maintenance of the sediment and erosion control measures must be such that they equal, or exceed, the requirements specified in the most recent version of the *North Carolina Sediment and Erosion Control Manual*. The devices shall be maintained on all construction sites, borrow sites, and waste pile (spoil) projects, including contractor-owned or leased borrow pits associated with the project.
 - b. For borrow pit sites, the erosion and sediment control measures must be designed, installed, operated, and maintained in accordance with the most recent version of the *North Carolina Surface Mining Manual*.
 - c. Reclamation measures and implementation must comply with the reclamation in accordance with the requirements of the Sedimentation Pollution Control Act and the Mining Act of 1971.
 - d. Sufficient materials required for stabilization and/or repair of erosion control measures and stormwater routing and treatment shall be on site at all times, except for publicly funded linear transportation projects when materials can be accessed offsite in a timely manner.
 - e. If the project occurs in waters or watersheds classified as Primary Nursery Areas (PNA's), Trout (Tr), SA, WS-I, WS-II, High Quality (HQW), or Outstanding Resource (ORW) waters, then the sediment and erosion control requirements contained within *Design Standards in Sensitive Watersheds* (15A NCAC 04B .0124) supercede all other sediment and erosion control requirements.
3. No Sediment and Erosion Control Measures in Wetlands or Waters

Sediment and erosion control measures should not be placed in wetlands or waters outside of the permitted impact areas without prior approval by the Division. If placement of sediment and erosion control devices in wetlands and waters is unavoidable, design and placement of temporary erosion control measures shall not be conducted in a manner that may result in dis-equilibrium of wetlands or stream beds or banks, adjacent to or upstream and down stream of the above structures. All sediment and erosion control devices shall be removed and the natural grade restored within two (2) months of the date that the Division of Land Resources or locally delegated program has released the project.

4. Construction Stormwater Permit NCG010000

Upon the approval of an Erosion and Sedimentation Control Plan issued by the Division of Land Resources (DLR) or a DLR delegated local erosion and sedimentation control program, an NPDES General stormwater permit (NCG010000) administered by the Division is automatically issued to the project. This General Permit allows stormwater to be discharged during land disturbing construction activities as stipulated by conditions in the permit. If your project is covered by this permit [applicable to construction projects that disturb one (1) or more acres], full compliance with permit conditions including the sedimentation control plan, self-monitoring, record keeping and reporting requirements are required. A copy of this permit and monitoring report forms may be found at http://h2o.enr.state.nc.us/su/Forms_Documents.htm.

The North Carolina Department of Transportation (NCDOT) shall be required to be in full compliance with the conditions related to construction activities within the most recent version of their individual NPDES (NCS000250) stormwater permit.

Water Quality Certification N^o. 3820

5. Work in the Dry

All work in or adjacent to stream waters shall be conducted in a dry work area. Approved best management practices from the most current version of the NC Sediment and Erosion Control Manual, or the NC DOT Construction and Maintenance Activities Manual, such as sandbags, rock berms, cofferdams, and other diversion structures shall be used to minimize excavation in flowing water. Exceptions to this condition require submittal to, and approval by, the Division of Water Quality.

6. Construction Moratoriums and Coordination

If activities must occur during periods of high biological activity (i.e. sea turtle or bird nesting), then biological monitoring may be required at the request of other state or federal agencies and coordinated with these activities. This condition can be waived through written concurrence on a case-by-case basis upon reasonable justification.

All moratoriums on construction activities established by the NC Wildlife Resources Commission (WRC), US Fish and Wildlife Service (USFWS), NC Division of Marine Fisheries (DMF), or National Marine Fisheries Service (NMFS) to lessen impacts on trout, anadromous fish, larval/post-larval fishes and crustaceans, or other aquatic species of concern shall be implemented. This condition can be waived through written concurrence on a case-by-case basis upon reasonable justification.

Work within the twenty-five (25) designated trout counties or identified state or federal endangered or threatened species habitat shall be coordinated with the appropriate WRC, USFWS, NMFS, and/or DMF personnel.

7. Riparian Area Protection (Buffer) Rules

Activities located in the protected 50-foot wide riparian areas (whether jurisdictional wetlands or not), within the Neuse, Tar-Pamlico, Catawba, Randleman, and Jordan (or any other basin with buffer rules), shall be limited to "uses" identified within and constructed in accordance with 15A NCAC 2B .0233, .0259, .0250, .0243, and .0267, and shall be located, designed, constructed, and maintained to have minimal disturbance to protect water quality to the maximum extent practicable through the use of best management practices. All buffer rule requirements, including diffuse flow requirements, must be met.

8. Water Supply Watershed Buffers

The 100-foot wide vegetative buffer (high-density development) or the 30-foot wide vegetative buffer (low density development) shall be maintained adjacent to all perennial waters except for allowances as provided in the Water Supply Watershed Protection Rules [15A NCAC 2B .0212 through .0215].

9. If concrete is used during the construction, then a dry work area should be maintained to prevent direct contact between curing concrete and stream water. Water that inadvertently contacts uncured concrete should not be discharged to surface waters due to the potential for elevated pH and possible aquatic life/fish kills.

10. Compensatory Mitigation

In accordance with 15A NCAC 2H .0506 (h), compensatory mitigation may be required for losses of 150 linear feet or more of streams (intermittent and perennial) and/or one (1) acre or more of wetlands. For linear, public transportation projects, impacts equal to or exceeding 150 linear feet per stream may require mitigation.

Water Quality Certification N^o. 3820

Buffer mitigation may be required for any project with Buffer Rules in effect at the time of application for buffer impacts resulting from activities classified as "Allowable with Mitigation" within the Buffer Rules or require a variance under the Buffer Rules.

A determination of buffer, wetland and stream mitigation requirements shall be made by the Division for any application to use this Certification. Design and monitoring protocols shall follow the US Army Corps of Engineers Wilmington District *Stream Mitigation Guidelines* (April 2003), or its subsequent updates. Compensatory mitigation plans shall be submitted for written Division approval as required in those protocols. Alternatively, the Division will accept payment into an in-lieu fee program or credit purchase from a mitigation bank.

Finally, the mitigation plan must be implemented and/or constructed before any permanent building or structure on site is occupied. In the case of public road projects, the mitigation plan must be implemented before the road is opened to the public whenever practical or at the earliest reasonable time during the construction of the project. Proof of payment to an in-lieu fee program or mitigation bank must be provided to the Division to satisfy this requirement.

- * 11. For all activities requiring re-alignment of streams, a stream relocation plan must be included for written Division approval. Relocated stream designs should include the same dimensions, patterns and profiles as the existing channel (or a stable reference reach if the existing channel is unstable), to the maximum extent practical. The new channel should be constructed in the dry and water shall not be turned into the new channel until the banks are stabilized. Vegetation used for permanent bank stabilization shall be limited to native woody species, and should include establishment of a 30-foot wide wooded and an adjacent 20-foot wide vegetated buffer on both sides of the relocated channel to the maximum extent practical. A transitional phase incorporating appropriate erosion control matting materials and seedling establishment is allowable. Rip-rap, A-Jacks, concrete, gabions or other hard structures may be allowed if it is necessary to maintain the physical integrity of the stream, however, the applicant must provide written justification and any calculations used to determine the extent of rip-rap coverage. Please note that if the stream relocation is conducted as a stream restoration as defined in the US Army Corps of Engineers Wilmington District, April 2003 *Stream Mitigation Guidelines*, the restored length can be used as compensatory mitigation for the impacts resulting from the relocation.

12. Stormwater Management Plan Requirements

- A. Linear public transportation projects will be required to treat stormwater runoff to the Maximum Extent Practicable in accordance with the practices described in the NCDOT Best Management Practices (BMP) Manual.
- B. All other projects shall comply with the requirements set forth below. In addition, the applicants shall follow the procedures explained in the version of *Protocol for Stormwater Management Plan (SMP) Approval and Implementation* that is in place on the date of the submittal of the SMP.
 - i. **Project Density:** Projects with SMPs that require 401 Oversight/ Express Unit approval shall be classified as either Low or High Density according to the criteria described below.
 - a. **Low Density:** A development shall be considered Low Density if ALL of the following criteria are shown to have been met.
 - 1. The overall site plan, excluding ponds, lakes, rivers (as specified in North Carolina's Schedule of Classifications) and saltwater wetlands

Water Quality Certification N°. 3820

(SWL), must contain less than 24% impervious surface area considering both current and future development.

2. All stormwater from the entire site must be transported primarily via vegetated conveyances designed in accordance with the most recent version of the NC DWQ Stormwater BMP Manual.
 3. The project must not include a stormwater collection system (such as piped conveyances) as defined in 15A NCAC 2B .0202(60).
 4. If a portion of project has a density equal to or greater than 24%, then the higher density area must be located in an upland area and away from surface waters and drainageways to the maximum extent practicable.
- b. **High Density:** Projects that do not meet all of the Low Density criteria described above are considered to be High Density, requiring the installation of appropriate BMPs as described below.
1. All stormwater runoff from the site must be treated by BMPs that are designed, at a *minimum*, to remove 85 percent of Total Suspended Solids (TSS).
 2. Projects located in watersheds that drain directly to waters containing the following supplemental classifications shall meet these additional requirements:

<i>Water Quality Supplemental Classification</i>	<i>Stormwater BMP Requirement</i>
§303(d)	Project-specific conditions may be added by the Division to target the cause of the water quality impairment.
NSW	A minimum of 30 percent total phosphorus and 30 percent total nitrogen removal, or other applicable nutrient reduction goal for the watershed as codified in the 15A NCAC 2B .0200 rules.
Trout (Tr)	A minimum of 30 percent total phosphorus and 30 percent total nitrogen removal; BMPs should also be designed to minimize thermal pollution.

3. All BMPs must be designed in accordance with the version of the *NC Division of Water Quality Stormwater Best Management Practices Manual* that is in place on the date of the submittal of the SMP. Use of stormwater BMPs other than those listed in the *Manual* may be approved on a case-by-case basis if the applicant can demonstrate that these BMPs provide equivalent or higher pollutant removal and water quality protection.
- ii. **Vegetated Setback:** In areas that are not subject to a state Riparian Area Protection Rule, a 30-foot wide vegetated setback must be maintained adjacent to streams, rivers and tidal waters as specified below.
- a. The width of the setback shall be measured horizontally from:

Water Quality Certification N^o. 3820

1. The normal pool elevation of impounded structures,
 2. The streambank of streams and rivers, and
 3. The mean high waterline of tidal waters, perpendicular to shoreline.
- b. The vegetated setback may be cleared or graded, but must be planted with and maintained in grass or other appropriate plant cover.
 - c. The DWQ may, on a case-by-case basis, grant a minor variance from the vegetated setback requirements pursuant to the procedures set forth in 15A NCAC 02B .0233(9)(b).
 - d. Vegetated setbacks and filters required by state rules or local governments may be met concurrently with this requirement and may contain coastal, isolated or 404 jurisdictional wetlands.
- iii. **Stormwater Flowing to Streams and Wetlands:** Stormwater conveyances that discharge to streams and wetlands must discharge at a non-erosive velocity prior to entering the stream or wetland during the peak flow from the ten-year storm.
 - iv. **Projects Below Written Authorization Thresholds:** Projects that are below written authorization thresholds must comply with the version of *Protocol for Stormwater Management Plan (SMP) Review and Approval* that is in place on the date of the certification for the project.
 - v. **Phased Projects:** The DWQ will allow SMPs to be phased on a case-by-case basis, with a final SMP required for the current phase and a conceptual SMP for the future phase(s). If the current phase meets the Low Density criteria, but future phase(s) do not meet the Low Density criteria, then the entire project shall be considered to be High Density.
13. If this Water Quality Certification is used to access building sites, all lots owned by the applicant must be buildable without additional fill. For road construction purposes, this General Water Quality Certification shall only be utilized from natural high ground to natural high ground.
14. Placement of Culverts and Other Structures in Waters and Wetlands

The application must include construction plans with cross-sectional details in order to indicate that the current stability of the stream will be maintained or enhanced (i.e., not result in head cuts).

Culverts required for this project shall be designed and installed in such a manner that the original stream profiles are not altered and allow for aquatic life movement during low flows. Existing stream dimensions (including the cross section dimensions, pattern, and longitudinal profile) must be maintained above and below locations of each culvert. Placement of culverts and other structures in waters, streams, and wetlands must be placed below the elevation of the streambed by one foot for all culverts with a diameter greater than 48 inches, and 20 percent of the culvert diameter for culverts having a diameter less than or equal to 48 inches, to allow low flow passage of water and aquatic life unless otherwise justified and approved by the Division

Water Quality Certification N^o. 3820

Installation of culverts in wetlands must ensure continuity of water movement and be designed to adequately accommodate high water or flood conditions. Additionally, when roadways, causeways or other fill projects are constructed across FEMA-designated floodways or wetlands, openings such as culverts or bridges must be provided to maintain the natural hydrology of the system as well as prevent constriction of the floodway that may result in destabilization of streams or wetlands.

Any rip rap required for normal pipe burial and stabilization shall be buried such that the original stream elevation is restored and maintained.

The establishment of native, woody vegetation and other soft stream bank stabilization techniques must be used where practicable instead of rip-rap or other bank hardening methods.

15. Additional site-specific conditions may be added to the written approval in order to ensure compliance with all applicable water quality and effluent standards.
- * 16. If an environmental document is required under the National or State Environmental Policy Act (NEPA or SEPA), then this General Certification is not valid until a Finding of No Significant Impact (FONSI) or Record of Decision (ROD) is issued by the State Clearinghouse.
17. Deed notifications or similar mechanisms shall be placed on all retained jurisdictional wetlands, waters and protective buffers in order to assure compliance for future wetland, water and buffer impact. These mechanisms shall be put in place at the time of recording of the property, or of individual lots, whichever is appropriate. A sample deed notification can be downloaded from the 401/Wetlands Unit web site at <http://portal.ncdenr.org/web/wq/swp/ws/401/certsandpermits/apply/forms>
The text of the sample deed notification may be modified as appropriate to suit to a specific project.
- * 18. Certificate of Completion

When written authorization is required for use of this certification, upon completion of all permitted impacts included within the approval and any subsequent modifications, the applicant shall be required to return the certificate of completion attached to the approval. One copy of the certificate shall be sent to the DWQ Central Office in Raleigh at 1650 Mail Service Center, Raleigh, NC, 27699-1650.
19. This General Certification shall expire three (3) years from the date of issuance of the written approval from the Division or on the same day as the expiration date of the corresponding Nationwide Permit 14 or Regional General Permit 198200031. In accordance with General Statute 136-44.7B, certifications issued to the NCDOT shall expire only upon expiration of the federal 404 Permit. The conditions in effect on the date of issuance of Certification for a specific project shall remain in effect for the life of the project, regardless of the expiration date of this Certification. If the construction process for approved activities will overlap the expiration and renewal date of the corresponding 404 Permit and the Corps allows for continued use of the 404 Permit, then the General Certification shall also remain in effect without requiring re-application and re-approval to use this Certification for the specific impacts already approved.
20. The applicant/permittee and their authorized agents shall conduct all activities in a manner consistent with State water quality standards (including any requirements resulting from compliance with §303(d) of the Clean Water Act), and any other appropriate requirements of State and Federal Law. If the Division determines that such standards or laws are not being met, including failure to sustain a designated or achieved use, or that State or Federal law is

Water Quality Certification N^o. 3820

being violated, or that further conditions are necessary to assure compliance, then the Division may reevaluate and modify this General Water Quality Certification.

Non-compliance with or violation of the conditions herein set forth by a specific fill project may result in revocation of this Certification for the project and may also result in criminal and/or civil penalties.

The Director of the North Carolina Division of Water Quality may require submission of a formal application for Individual Certification for any project in this category of activity, if it is determined that the project is likely to have a significant adverse effect upon water quality including state or federally listed endangered or threatened aquatic species or degrade the waters so that existing uses of the wetland or downstream waters are precluded.

Public hearings may be held for specific applications or group of applications prior to a Certification decision if deemed in the public's best interest by the Director of the North Carolina Division of Water Quality.

Effective date: April 6, 2010

DIVISION OF WATER QUALITY

By



Coleen H. Sullins

Director

History Note: Water Quality Certification (WQC) Number 3820 issued April 6, 2010 replaces WQC Number 3704 issued November 1, 2007, WQC Number 3627 issued March 2007, WQC Number 3404 issued March 2003, WQC Number 3375 issued March 18, 2002, WQC Number 3289 issued June 1, 2000, WQC Number 3103 issued on February 11, 1997, WQC Number 2732 issued May 1, 1992, WQC Number 2666 issued January 21, 1992, and WQC Number 2177 issued November 5, 1987. This WQC is rescinded when the Corps of Engineers re-authorizes Nationwide Permit 14 or Regional General Permit 198200031 or when deemed appropriate by the Director of the Division of Water Quality.

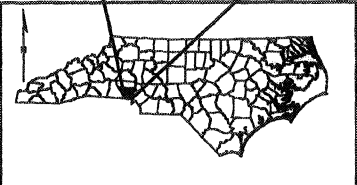
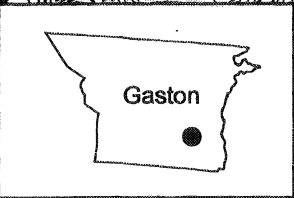
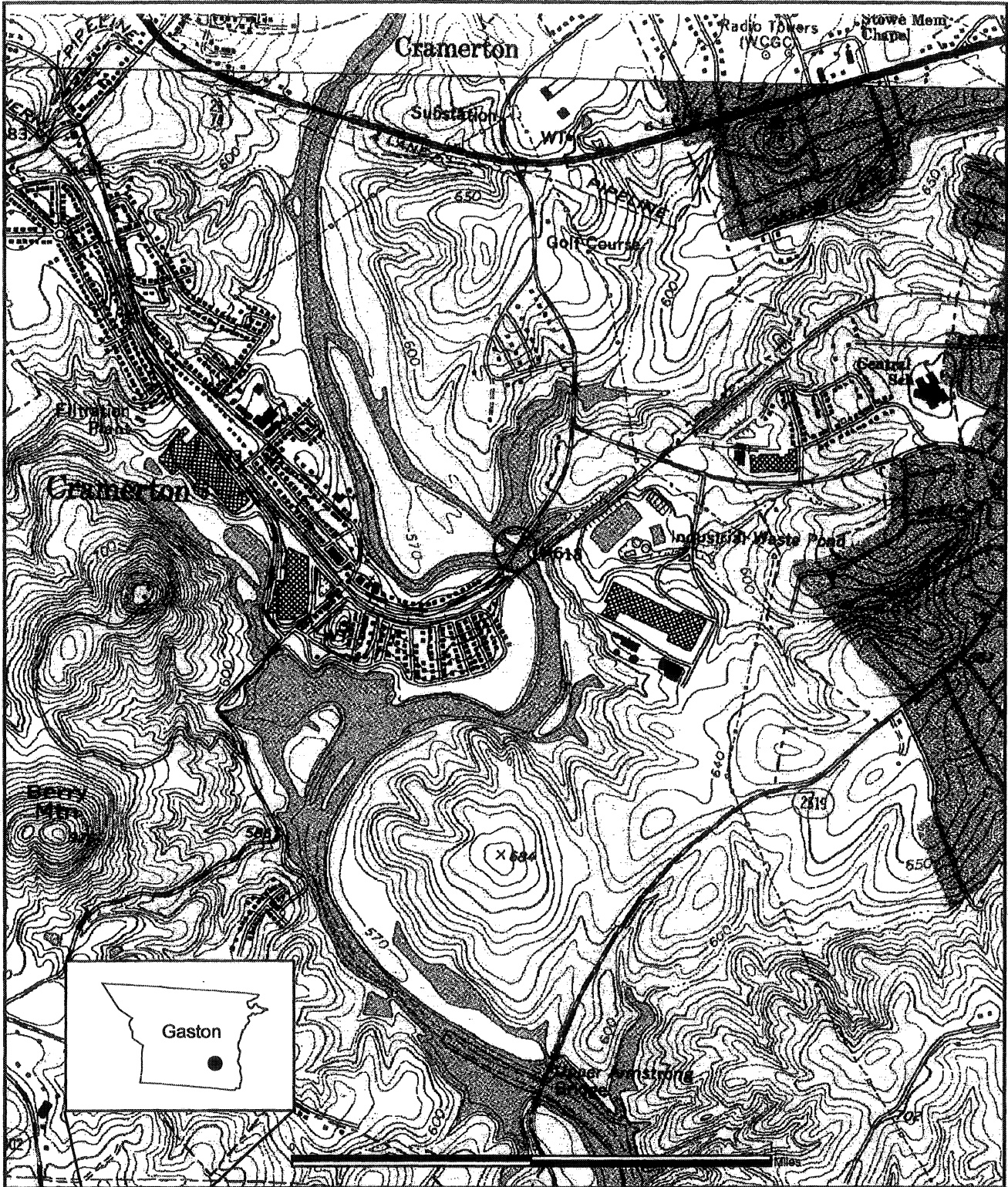

B-4752
Gaston County
 Replace Bridge No. 6 on SR 2014 over
 South Fork Catawba River

FIGURE 1



Prepared by the NCDOT
 Project Development &
 Environmental Analysis Branch
 Natural Environment Unit

STATE OF NORTH CAROLINA
 DIVISION OF HIGHWAYS
GASTON COUNTY

LOCATION: BRIDGE NO. 6 ON SR 2014 (LAKEWOOD RD)
 OVER SOUTH FORK CATAWBA RIVER
 TYPE OF WORK: GRADING, PAVING, DRAINAGE, AND STRUCTURE

WETLAND AND SURFACE WATER IMPACTS PERMIT

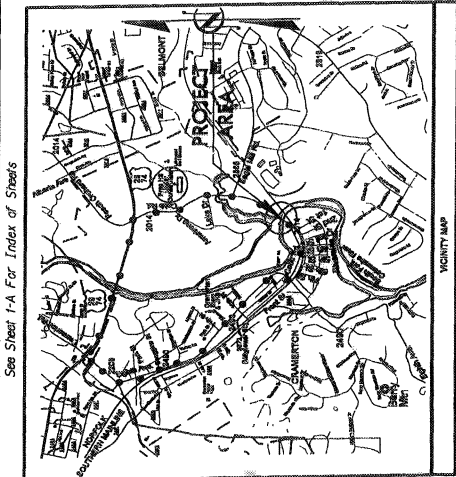

See Sheet 1-A For Index of Sheets

STATE PROJECT NUMBER	B-4752
PROJECT SHEET NUMBER	1
DATE	
DESIGNER	BRST-2014(3)
CHECKER	BRST-2014(3)
APPROVER	BRST-2014(3)
CONTRACTOR	BRST-2014(3)

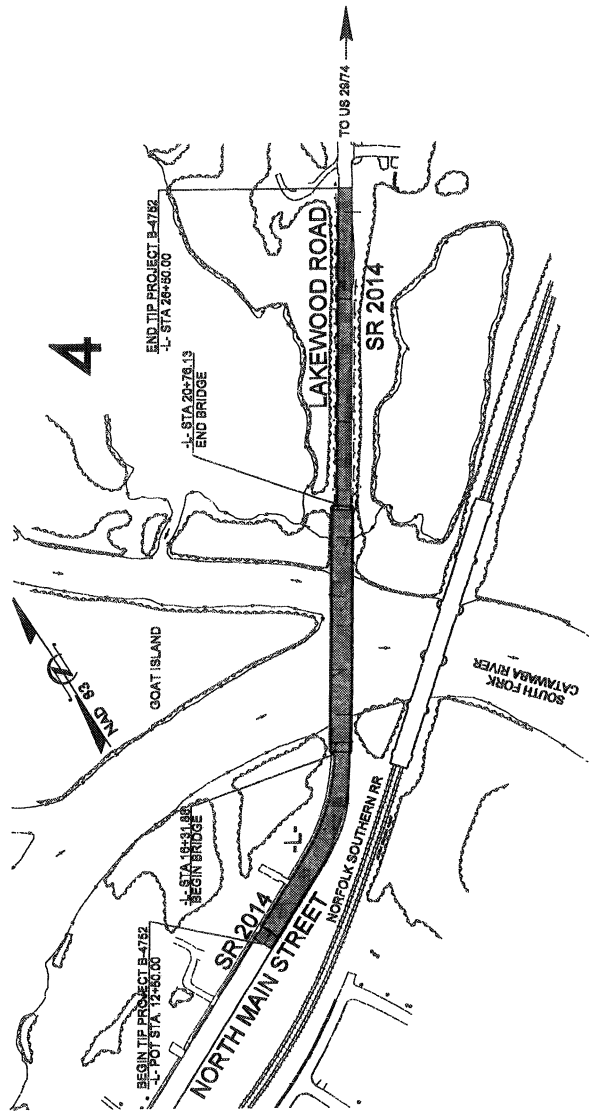

PRELIMINARY PLANS
 DO NOT USE FOR CONSTRUCTION

DIVISION OF HIGHWAYS
 STATE OF NORTH CAROLINA

HYDRAULICS ENGINEER

PROJECT ENGINEER: ROADWAY DESIGN ENGINEER

Prepared in the Office of:
DIVISION OF HIGHWAYS
 1000 North Hargett St., Raleigh, NC, 27611

RIGHT OF WAY DATE: DECEMBER 21, 2011
 LETTING DATE: AUGUST 21, 2012

PROJECT MANAGER: JASON MOORE, P.E.
 PROJECT ENGINEER: JEANIE TYSON

PROJECT LENGTH

LENGTH ROADWAY F.A. PROJECT BRST-2014(3) = 0.181
 LENGTH STRUCTURE F.A. PROJECT BRST-2014(3) = 0.084
 TOTAL LENGTH F.A. PROJECT BRST-2014(3) = 0.265

DESIGN DATA

ADT 2012 = 4740
 ADT 2035 = 7500
 DHV = 10%
 D = 70%
 T = 4%
 V = 40 MPH
 * TTST 1% DUAL 3%
 FUNCTIONAL CLASSIFICATION: MINOR ARTERIAL
 SUBREGIONAL TIER DESIGN



CONTRACT: C203014
 TYP PROJECT: B-4752

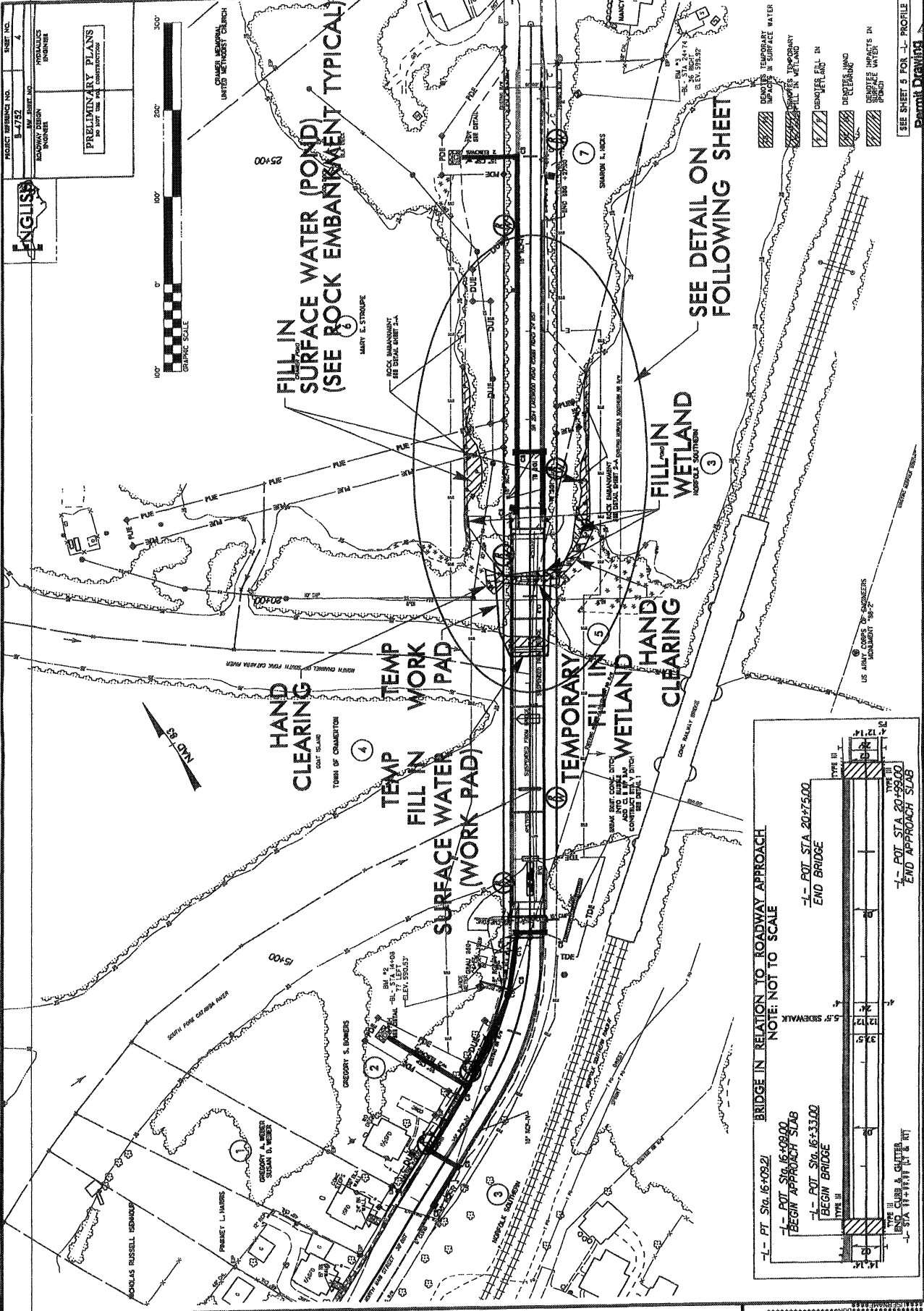

RW REVISION - REVISED PROP. DUAL UTILITY EASEMENT AND MARKERS AT L- STA. 15+03.00 THRU STA. 26+00.00 LT. - SEC 12/31/11
 12/17/99

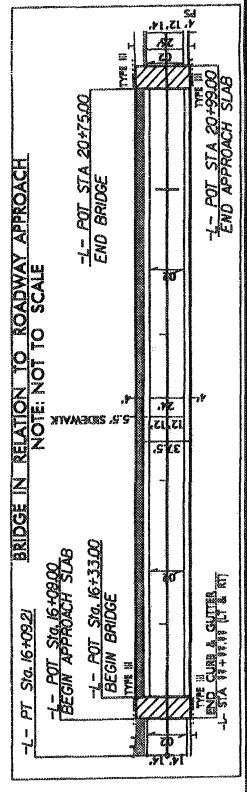

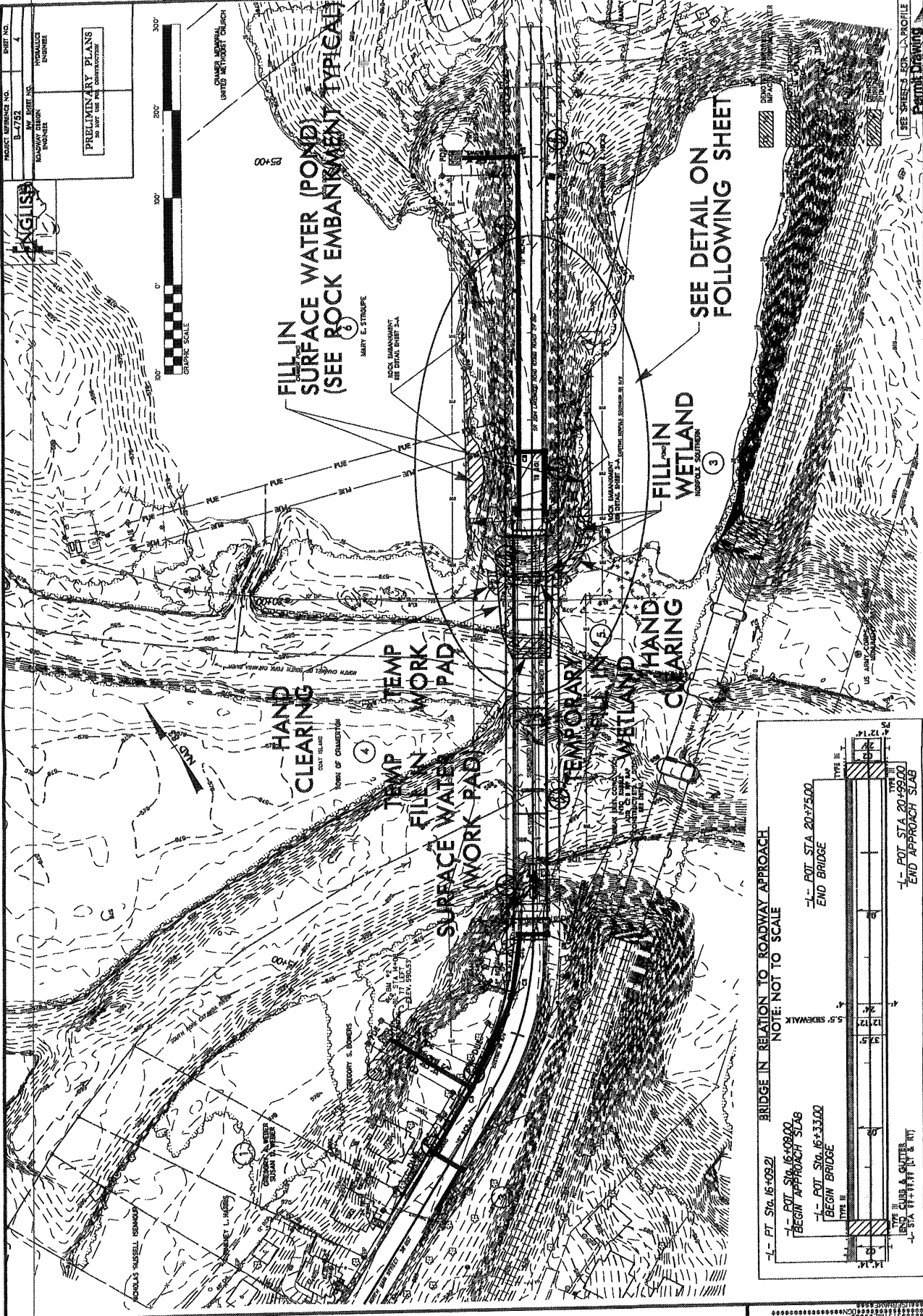

RW REVISION - REVISED PROP. DUAL UTILITY EASEMENT AND MARKERS AT 1'- STA. 15+03.00 LT. - SEC 12/13/11
 REMOVED PROP. SIDEWALK BETWEEN 1'- STA. 20+99.00 THRU STA. 26+00.00 LT. - SEC 12/13/11

PROJECT REFERENCE NO. 3-1752
 DRAWING NUMBER 3-1752
 ROADWAY DESIGN NUMBER
 INCOMPLETE PLANS
 NO NOT FOR CONSTRUCTION
 PRELIMINARY PLANS
 NO NOT FOR CONSTRUCTION

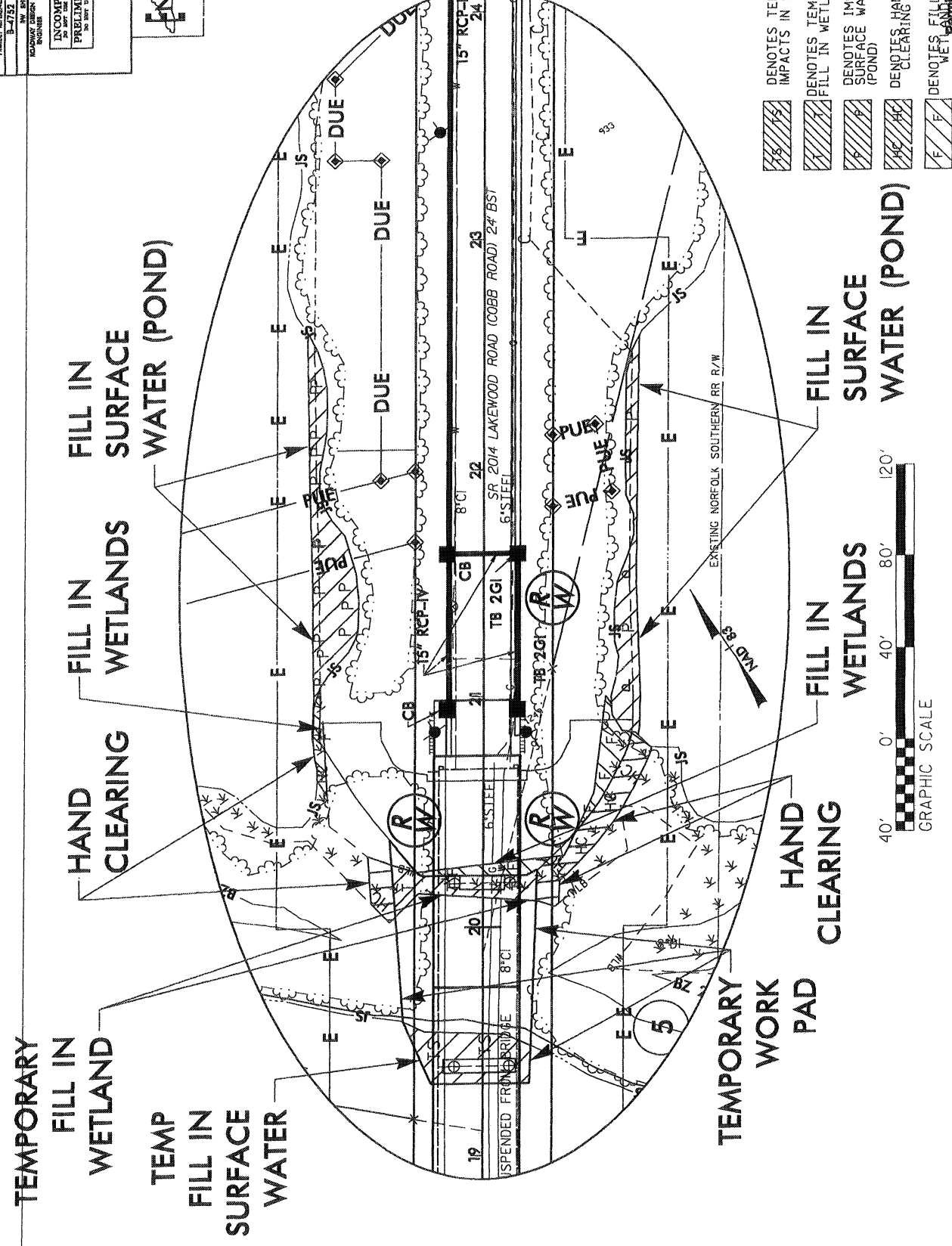

TEMPORARY WETLAND

FILL IN SURFACE WATER

TEMPORARY WORK PAD

HAND CLEARING

FILL IN WETLANDS





FILL IN SURFACE WATER (POND)

TEMPORARY WORK PAD

HAND CLEARING

FILL IN WETLANDS

FILL IN SURFACE WATER (POND)

-  DENOTES TEMPORARY IMPACTS IN SURFACE WATER
-  DENOTES TEMPORARY FILL IN WETLAND
-  DENOTES IMPACTS IN SURFACE WATER (POND)
-  DENOTES HAND CLEARING
-  DENOTES FILL IN WETLANDS

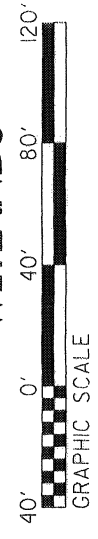

PROJECT DRAWING NO. E-219 SHEET NO. 1
 ROADWAY DESIGN ENGINEER
 INCOMPLETE PLANS
 DO NOT USE FOR CONSTRUCTION
 PRELIMINARY PLANS
 DO NOT USE FOR CONSTRUCTION

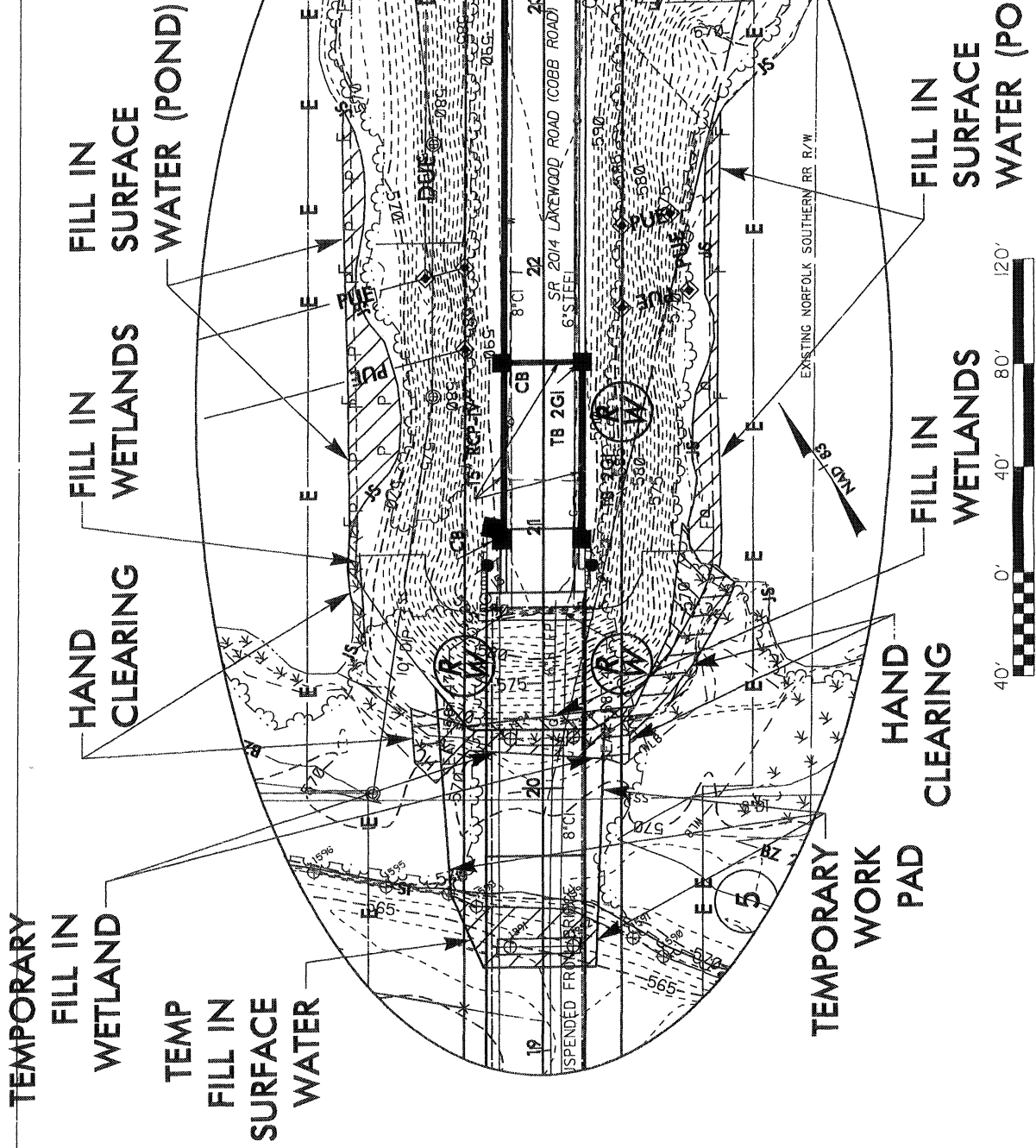

- DENOTES TEMPORARY IMPACTS IN SURFACE WATER
- DENOTES TEMPORARY FILL IN WETLAND
- DENOTES IMPACTS IN SURFACE WATER (POND)
- DENOTES HAND CLEARING
- DENOTES FILL IN WETLAND

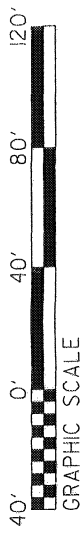

TEMPORARY FILL IN WETLAND

TEMP FILL IN SURFACE WATER

HAND CLEARING

FILL IN WETLANDS

FILL IN SURFACE WATER (POND)

TEMPORARY WORK PAD

HAND CLEARING

FILL IN WETLANDS

FILL IN SURFACE WATER (POND)

PROJECT REFERENCE NO. 5
SHEET NO. 5
CITY OF DENVER
ENGINEER

PRELIMINARY PLANS
DO NOT USE FOR CONSTRUCTION

1- SR 2014

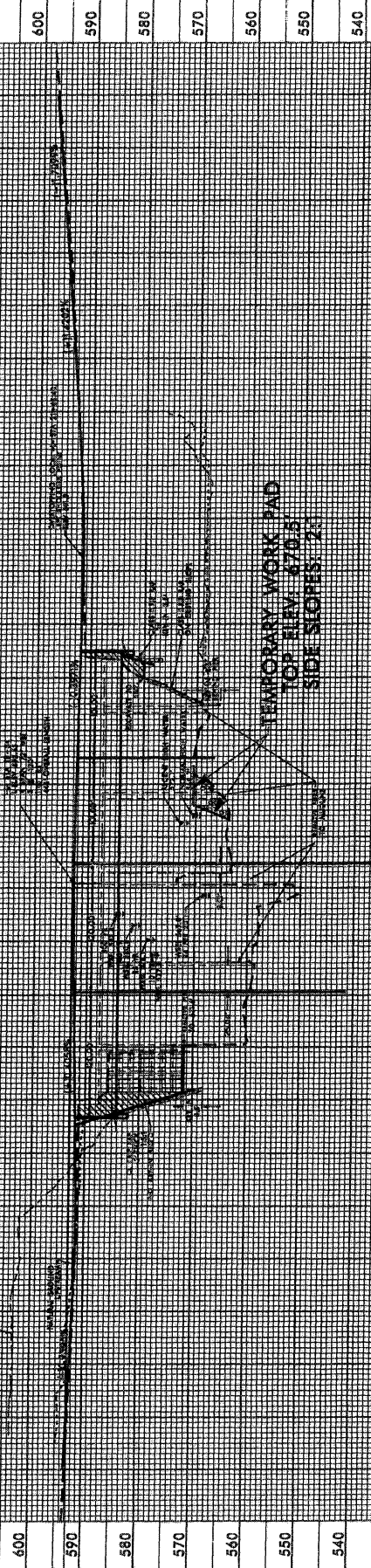

PROJECT REFERENCE NO. SHEET

B-4752 8

PROFESSIONAL ENGINEER	ENGINEER

ROCK EMBANKMENT TYPICAL

591.23

0.020

591.70

ROADWAY EMBANKMENT

ALLUVIAL

1:7

POND

WATER SURFACE
022011 - 569.0'

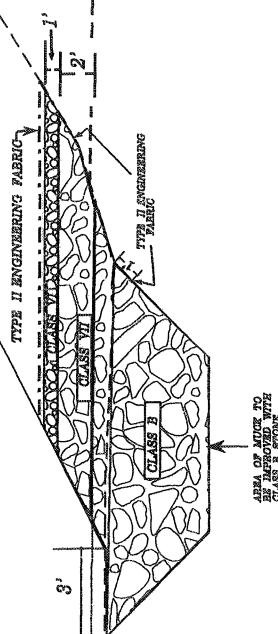

AREA OF STONE TO
BE APPROVED WITH
CLASS B STONE



GEO TECHNICAL ENGINEERING UNIT

EASTERN REGIONAL OFFICE

WESTERN REGIONAL OFFICE

CONTRACT OFFICE

STATE OF NORTH CAROLINA
DEPARTMENT OF TRANSPORTATION
RALEIGH

BRIDGE #09 ON SR 2014 LAKEWOOD
RD. OVER SOUTH FORK OF THE
CATAWBA RIVER

PREPARED BY: J.P. ROGERS	DATE DRAFT:
REVIEWED BY: J.R. FARRER	DATE DRAFT:

NO.	BY	DATE INCL.	DATE
1			
2			

Sheet 8 of 10

P 46

WETLAND PERMIT IMPACT SUMMARY															
Site No.	Station (From/To)	Structure Size / Type	WETLAND IMPACTS				SURFACE WATER IMPACTS								
			CAMA Permanent Fill In Wetlands (ac)	404 Permanent Fill In Wetlands (ac)	Temp. Fill In Wetlands (ac)	Excavation In Wetlands (ac)	Mechanized Clearing In Wetlands (ac)	Hand Clearing in Wetlands (ac)	Permanent SW impacts (ac)	Temp. SW impacts (ac)	Existing Channel Impacts Permanent (ft)	Existing Channel Impacts Temp. (ft)	Natural Stream Design (ft)		
1	-L- Sta 20+13 - 22+60	BRIDGE & APPROACH FILL		0.014				0.027	0.066						
1	-L- Sta 19+31 - 20+22	Temporary Work Pad			0.013						0.020				
TOTALS:				0.01	0.01			0.03	0.07		0.02				

NOTE: Permanent Surface Water Impacts include Interior Bents 2 & 3 which will be a single six foot diameter shaft per bent.
 Permanent Surface Water Impacts due to bents: 56.5 sq. ft.
 Permanent Surface Water (Pond) impacts due to fill: 2,799 sq. ft.

<0.01 acre of Temporary Fill in Wetlands in the Hand Clearing areas for erosion control measures.

Existing Pier 1: lower portion will remain to stabilize stream bank.
 Existing Pier 2 will be removed. Area is 2 @ 3'x3' = 18 sq. ft.
 Existing Pier 3 will be removed. Area is 251 sq. ft.
 Existing Pier 4 will be removed. Area is 12x21.8 sq.in.=261.6 sq.in.=1.8 sq. ft.
 Existing Pier 5 will be removed. Area is 251 sq. ft.
 Total area of piers to be removed: 522 sq. ft.

Proposed Piers: 2x28.27 sq.ft.=56.5 sq.ft.
 Net decrease of impacts due to piers:
 522 sq.ft.-57 sq.ft.=465 sq.ft. less impact with proposed bridge than with existing bridge due to bent design

N.C.D.O.T.
 DIVISION OF HIGHWAYS
 GASTON COUNTY
 PROJECT: 38524.1.1 (B-4752)
 BRIDGE NO. 6 ON
 SR 2014 (LAKEWOOD RD)
 OVER SOUTH FORK CATAWBA RIVER
 SHEET 1 OF (1/20/2012)

See Sheet 1-A For Index of Sheets

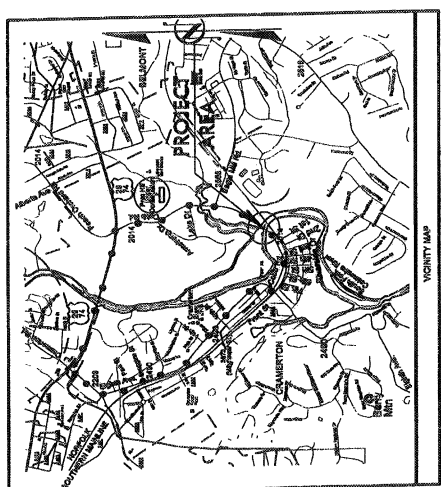

STATE OF NORTH CAROLINA DIVISION OF HIGHWAYS GASTON COUNTY

**LOCATION: BRIDGE NO. 6 ON SR 2014 (LAKEWOOD RD)
OVER SOUTH FORK CATAWBA RIVER**
TYPE OF WORK: GRADING, PAVING, DRAINAGE, AND STRUCTURE
BUFFER IMPACTS PERMIT

NO. N.C.	B-4752	DATE	1
PROJECT NUMBER	B-4752	DATE	1
SECTION NUMBER		DATE	
DATE		DATE	
BY	RM/LUTL	DATE	
FOR	CONSTR.	DATE	

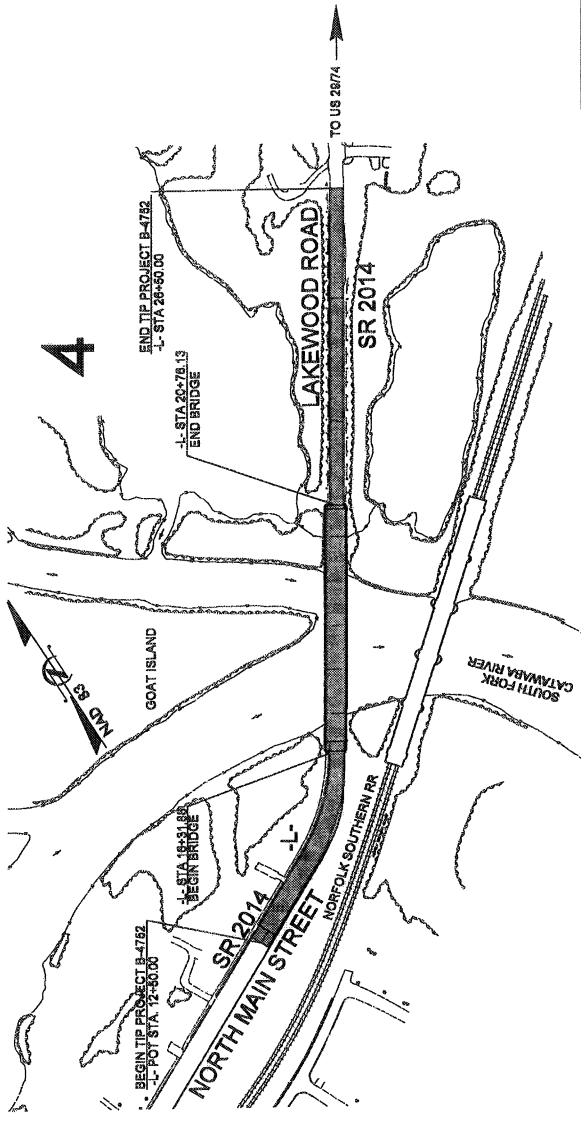

PRELIMINARY PLANS
DO NOT USE FOR CONSTRUCTION

DIVISION OF HIGHWAYS
STATE OF NORTH CAROLINA



HYDRAULICS ENGINEER: _____
 ROADWAY DESIGN ENGINEER: _____
 PROJECT NUMBER: _____

Prepared in the Office of:
DIVISION OF HIGHWAYS
 2004 Birch Ridge Dr., Raleigh, NC, 27610
 2012 STANDARD SPECIFICATIONS
 RIGHT OF WAY DATE: DECEMBER 21, 2011
 LETTING DATE: AUGUST 21, 2012
 PROJECT MANAGER: JASON MOORE, P.E.
 PROJECT DESIGN ENGINEER: JEANIE TYSON

PROJECT LENGTH	
LENGTH ROADWAY F.A. PROJECT BRSTP-2014(3)	= 0.181
LENGTH STRUCTURE F.A. PROJECT BRSTP-2014(3)	= 0.084
TOTAL LENGTH F.A. PROJECT BRSTP-2014(3)	= 0.265

DESIGN DATA	
ADT 2012 =	4740
ADT 2035 =	7500
DHY =	10%
D =	70%
T =	4%
V =	40 MPH
* T1ST 1% DUAL 5% FUNCTIONAL CLASSIFICATION: MINOR ARTERIAL SUBREGIONAL TIER DESIGN	



TIP PROJECT: B-4752

CONTRACT: C203014

*****SYSTEM*****
*****RENAME*****

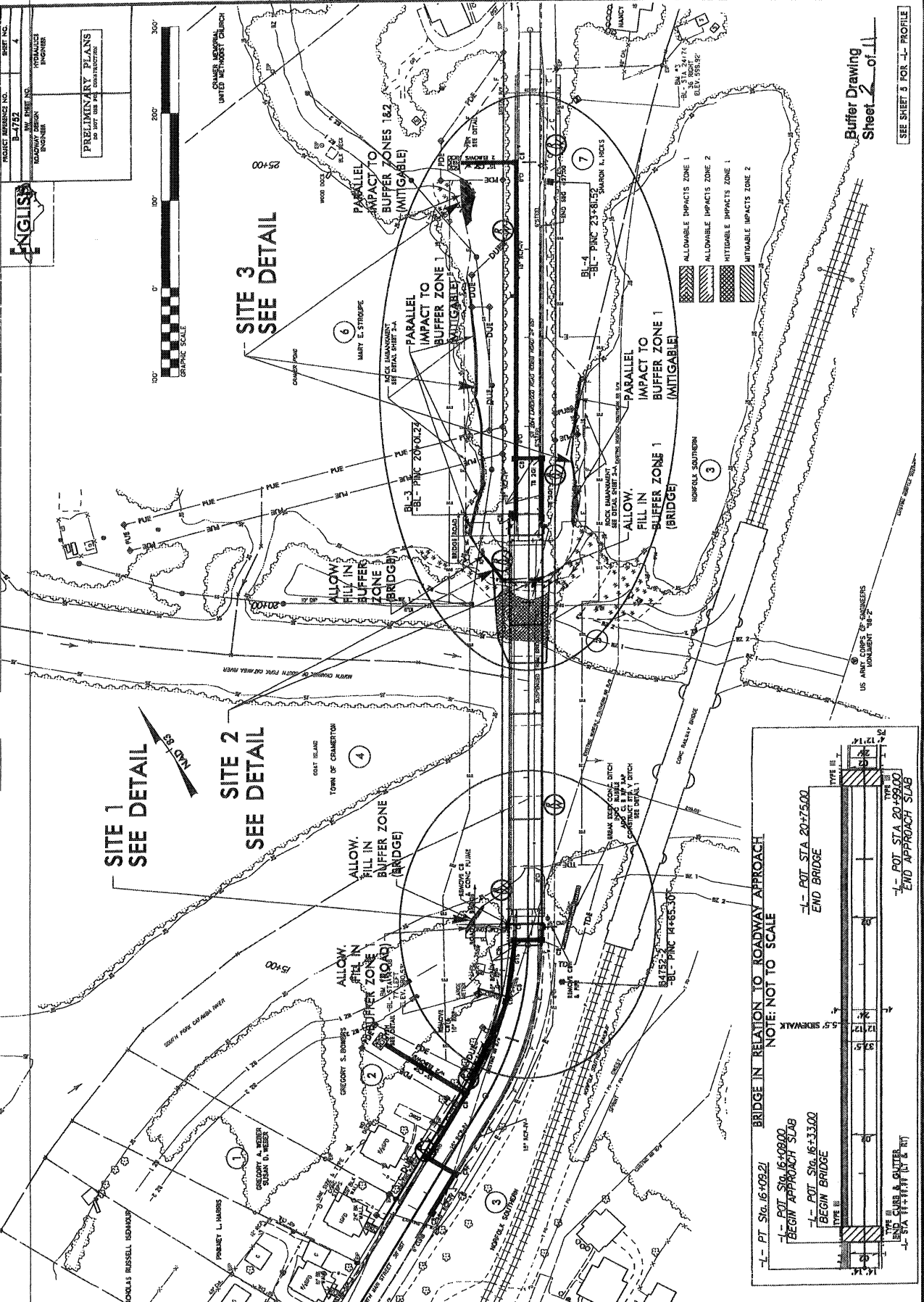

PROJECT NUMBER NO. B-4752
 SHEET NO. 4
 PRELIMINARY PLANS
 DO NOT USE FOR CONSTRUCTION

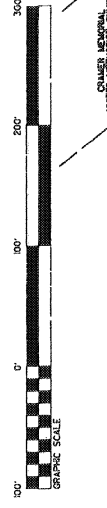

SITE 1
SEE DETAIL

SITE 2
SEE DETAIL

SITE 3
SEE DETAIL

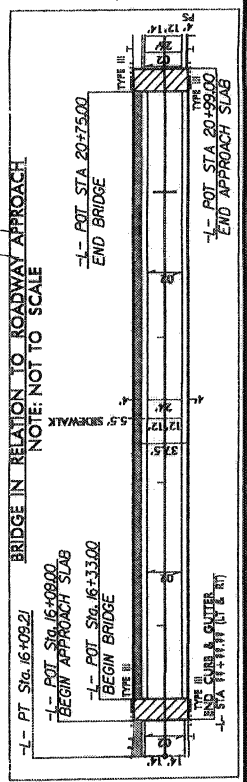

RW REVISION - REVISED PROP DUAL UTILITY EASEMENT AND MARKERS AT STA. 15+03.00 LT. - SEC 12A/31
 REMOVED PROP SIDEWALK BETWEEN STA. 20+99.00 THRU STA. 26+00.00 LT. - SEC 12A/31

Buffer Drawing
 Sheet 2 of 11

SEE SHEET 3 FOR -L- PROFILE

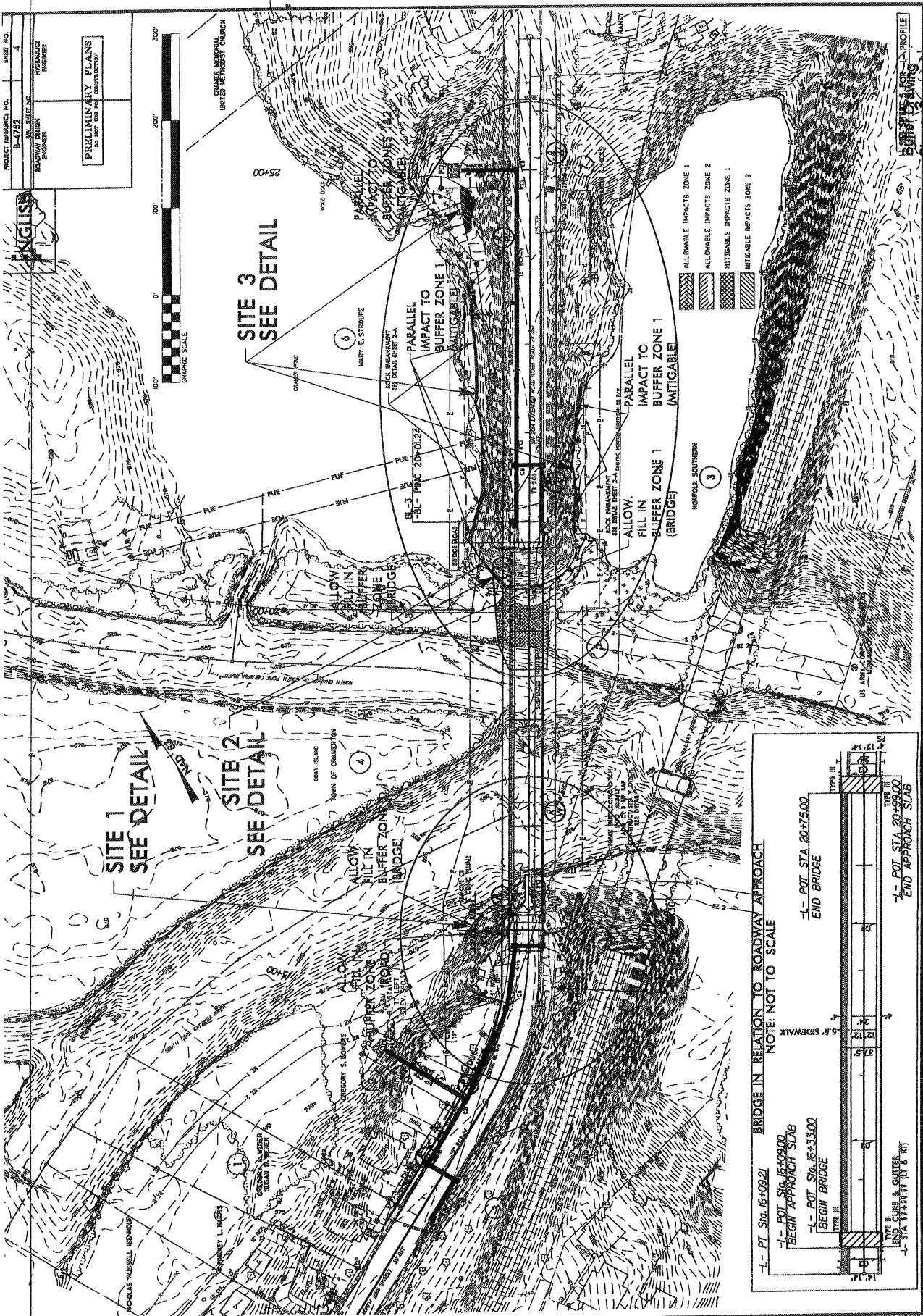

PROJECT REFERENCE NO. B-4752
 SHEET NO. 4
 HYDRAULIC ENGINEER
 PRELIMINARY PLANS
 DO NOT USE FOR CONSTRUCTION

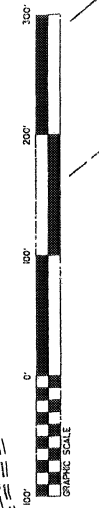

SITE 1
SEE DETAIL

SITE 2
SEE DETAIL

SITE 3
SEE DETAIL

BRIDGE IN RELATION TO ROADWAY APPROACH
 NOTE: NOT TO SCALE

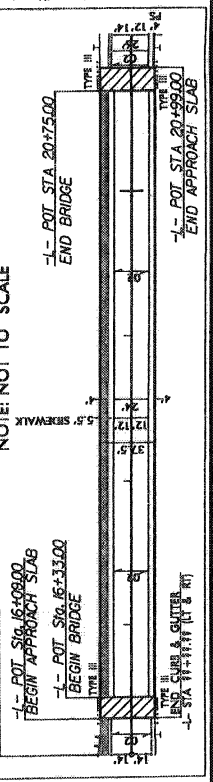

RW REVISION - REVISED PROP. DUAL UTILITY EASEMENT AND MARKERS AT STA. 15+03.00 LT. - STA. 15+03.00 LT. - STA. 20+99.00 THRU STA. 26+00.00 LT. - SEC. 12A/11

Sheet 3 of 11

PROJECT REFERENCE NO.	SHEET NO.
DATE	SCALE
DESIGNED BY	CHECKED BY
DRAWN BY	APPROVED BY
ENGINEER	ENGINEER



ALLOW.
FILL IN
BUFFER ZONE 1
(ROAD)

ALLOW.
FILL IN
BUFFER ZONE 1
(BRIDGE)

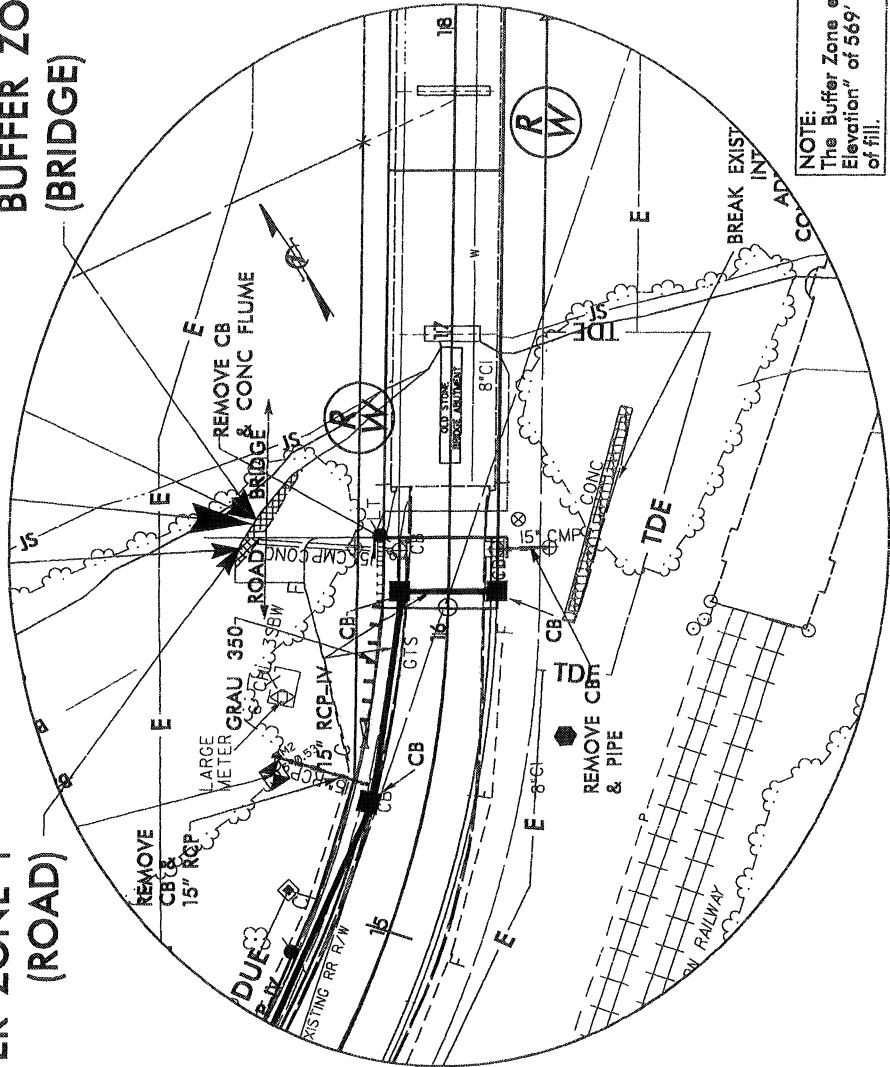

NOTE:
The Buffer Zone exists from "Full Pool Elevation" of 569' to the existing toe of fill.

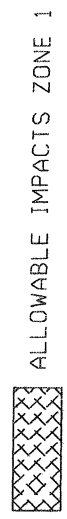
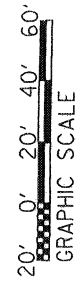

SITE 1

PROJECT REFERENCE NO.	SHEET NO.
ANAL. BY: J.M.A.	DATE: 10/11/00
ROADWAY DESIGN ENGINEER	PROVINCIAL ENGINEER



ALLOW.
FILL IN
BUFFER ZONE 1
(ROAD)

ALLOW.
FILL IN
BUFFER ZONE 1
(BRIDGE)

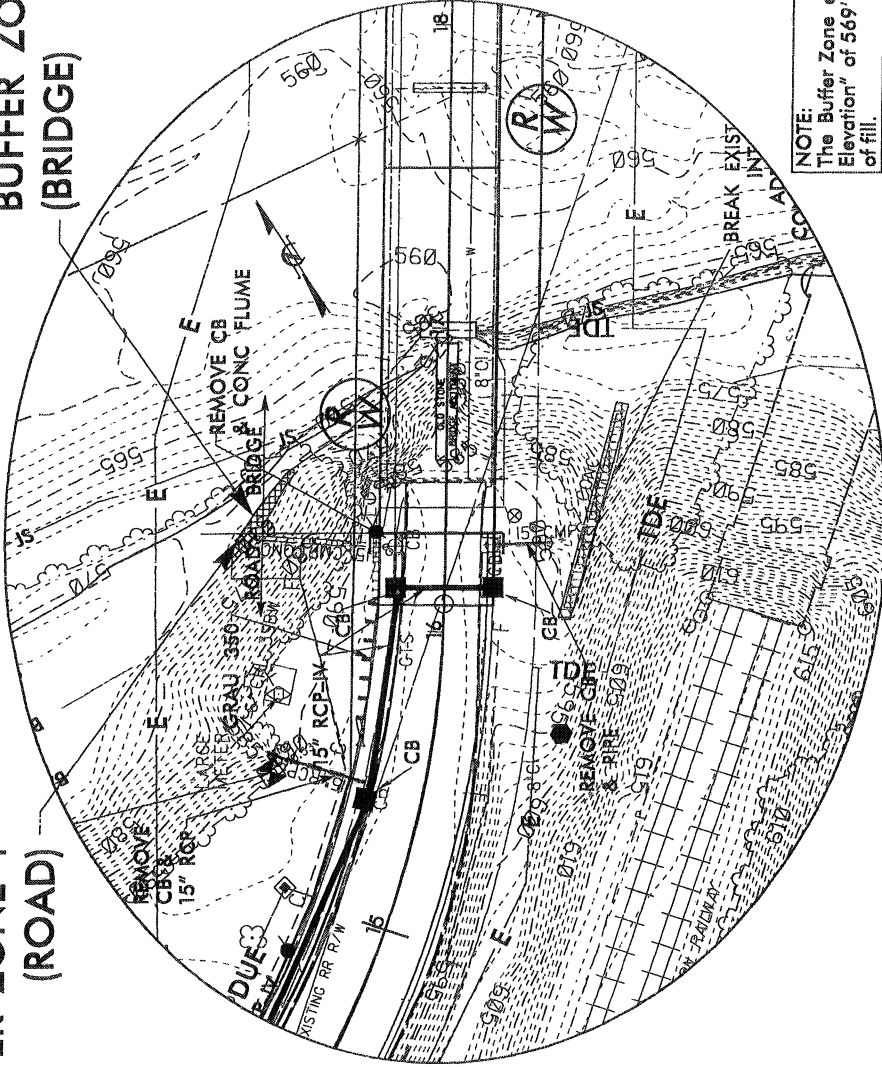

NOTE:
The Buffer Zone exists from "Full Pool Elevation" of 569' to the existing toe of fill.



ALLOWABLE IMPACTS ZONE 1

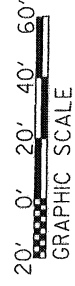

SITE 1

PROJECT REFERENCE NO. B-4782

SHEET NO. 11

HYDRAULICS ENGINEER



SITE 3 MITIGABLE FILL IN BUFFER ZONES 1&2 (PARALLEL)

SITE 3 MITIGABLE FILL IN BUFFER ZONE 1 (PARALLEL)

SITE 2 ALLOW. FILL IN BUFFER ZONE 1 (BRIDGE)

SITE 2 TEMP. WORK PAD

SITE 2 ALLOW. FILL IN BUFFER ZONE 1 (BRIDGE, for TEMP WORK PAD)

SITE 2 ALLOW. FILL IN BUFFER ZONE 1 (BRIDGE)

SITE 3 MITIGABLE FILL IN BUFFER ZONE 1 (PARALLEL)

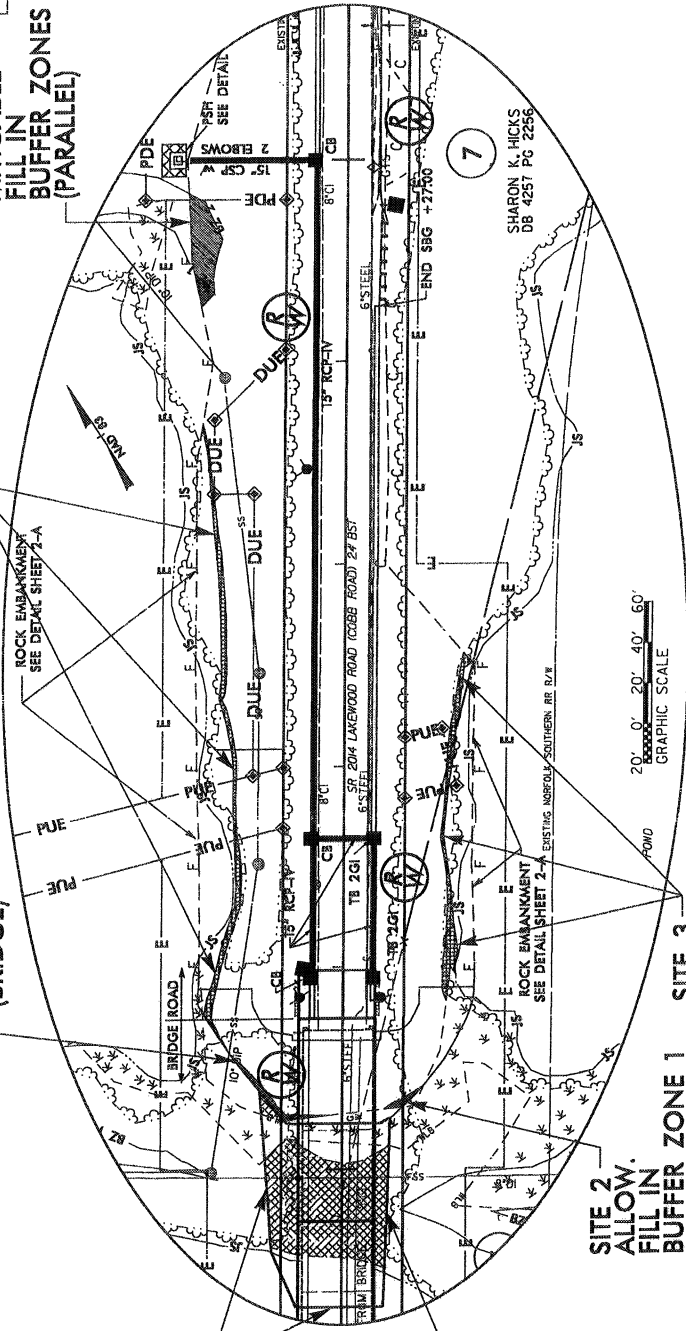

- ALLOWABLE IMPACTS ZONE 1
- ALLOWABLE IMPACTS ZONE 2
- MITIGABLE IMPACTS ZONE 1
- MITIGABLE IMPACTS ZONE 2

NOTE: The Buffer Zone exists from "Full Pool Elevation" of 569' to the existing toe of fill.

PROJECT: BIRMINGHAM, AL.	SHEET NO.:
B-4723	
DATE: 05/11/09	DRAWN BY:
	HYDRAULICS ENGINEER
	ENGINEER

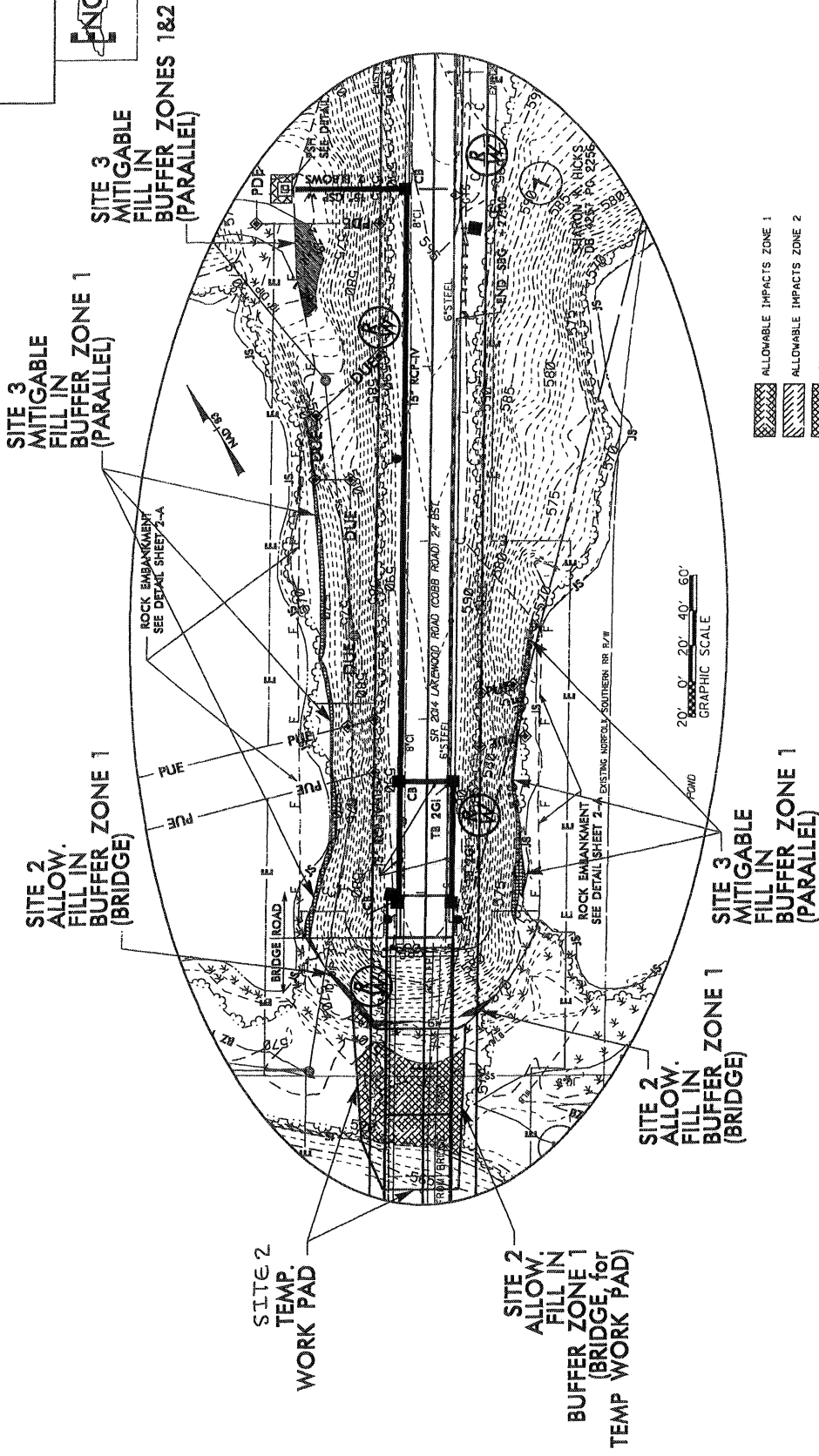

[Symbol] ALLOWABLE IMPACTS ZONE 1
 [Symbol] ALLOWABLE IMPACTS ZONE 2
 [Symbol] MITIGABLE IMPACTS ZONE 1
 [Symbol] MITIGABLE IMPACTS ZONE 2

NOTE:
 The Buffer Zone exists from "Full Pool Elevation" of 569' to the existing toe of fill.

Buffer Drawing
Sheet 7 of 11

PROJECT: BERNHARDT, INC. SHEET: ALL
6-4/12 5
DRAWN BY: J. W. BARNETT
CHECKED BY: J. W. BARNETT

PRELIMINARY PLANS
NO PART OF THIS DRAWING TO BE USED FOR CONSTRUCTION

1- SR 2014

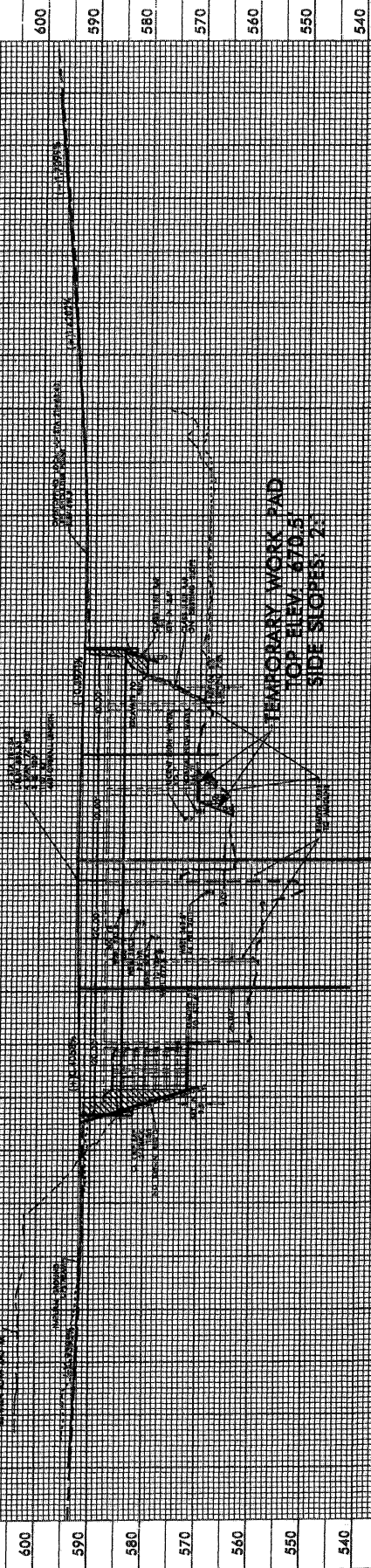

Access for removal of existing bents #2 & #3 and construction of new bents will be provided by barge. A temporary work pad will be used to aid in removal of bent #2 and launching the barges.

Sheet 6 of 11

PROJECT REFERENCE NO. **SECRET**
B-4752

ENGINEER	DATE	SCALE
ENGINEER		

ROCK EMBANKMENT TYPICAL

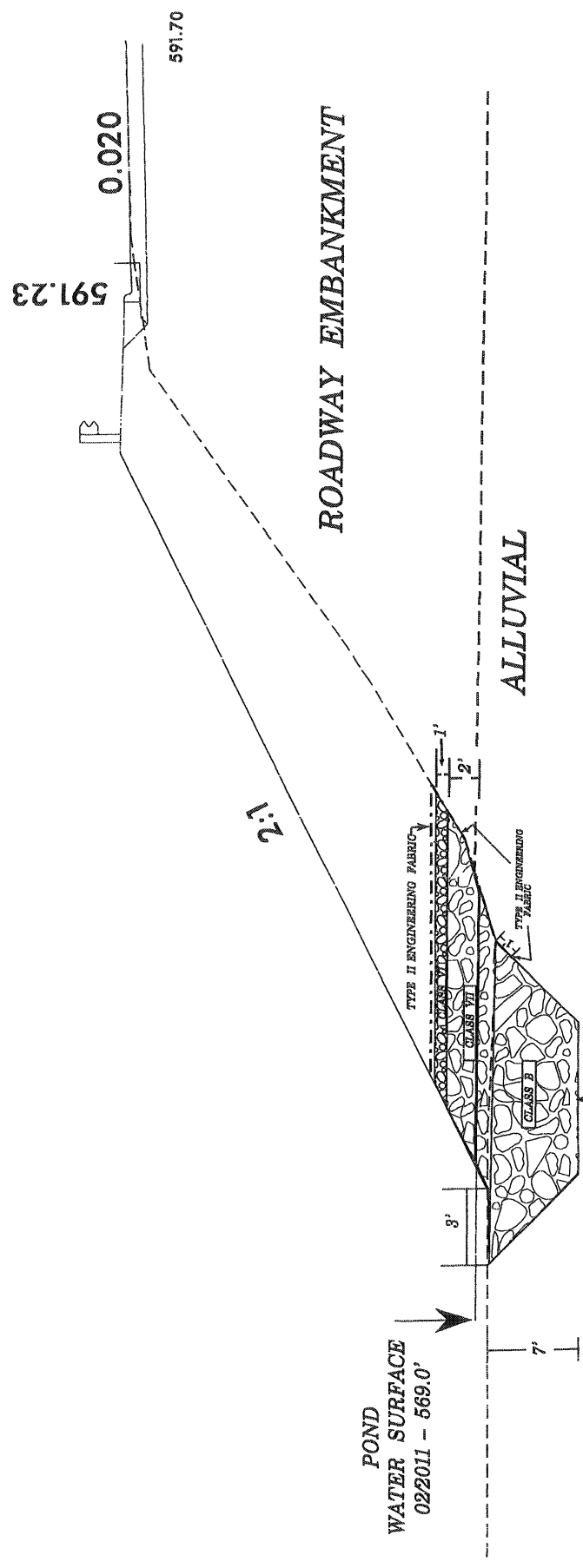

POND
WATER SURFACE
022011 - 569.0'

AREA OF ROCK TO
BE REPLACED WITH
CLASS B FILLING

GEO TECHNICAL ENGINEERING UNIT

EASTERN REGIONAL OFFICE
 WESTERN REGIONAL OFFICE
 CONTRACT OFFICE

STATE OF NORTH CAROLINA
DEPARTMENT OF TRANSPORTATION
RALEIGH

BRIDGE #06 ON SR 2014 LAKEWOOD
RD. OVER SOUTH FORK OF THE
CATAWBA RIVER

REVISED BY: **BUNNY**
DATE: **02/20/11**

SHEET **1** OF **2**

PREPARED BY: JF FOSBER	DATE: 02/01/11
REVIEWED BY: JF FOSBER	DATE: 02/01/11

BUFFER IMPACTS SUMMARY

SITE NO.	STRUCTURE SIZE / TYPE	STATION (FROM/TO)	IMPACT				MITTIGABLE			BUFFER REPLACEMENT			
			TYPE		ALLOWABLE		TOTAL (ft ²)	ZONE 1 (ft ²)	ZONE 2 (ft ²)	TOTAL (ft ²)	ZONE 1 (ft ²)	ZONE 2 (ft ²)	
			ROAD CROSSING	BRIDGE	PARALLEL IMPACT	ZONE 1 (ft ²)							ZONE 2 (ft ²)
1	Roadway Approach	-L- Sta 16+30 Lt.	X			35							
1	Bridge	-L- Sta 16+40 Lt.	X			91							
2	Bridge Pier	-L- Sta 19+74	X			28							
2	Bridge	-L- Sta 20+40 Lt & Rt	X			3167							
3	Roadway Approach (Parallel)	-L- Sta 20+75 - 24 +84 Lt. & Rt.		X				1149	492				
TOTAL:						3321		1149	492				

N.C. DEPT. OF TRANSPORTATION
 DIVISION OF HIGHWAYS
 GASTON COUNTY
 PROJECT: 38524.1.1 (B-4752)
 1/20/2012
 SHEET OF

NOTE:
 Site 2:
 A Temporary Work Pad will be built under a portion of Span 3 and all of Span 4 to allow construction of the bridge and provide access to the barges. This pad will create temporary impacts to Buffer Zone 1. The temporary impacts measure 2,973 sq. ft.
 The total impact of 3,167 sq. ft. shown for site 2 includes the 2,973 sq. ft. of temporary impact.