

STATE OF NORTH CAROLINA
DEPARTMENT OF TRANSPORTATION

CUMBERLAND COUNTY
SIGNING PLAN

LOCATION: I-95 BUS LOOP & 301 - REPLACE BRIDGE No. 85 OVER
CAPE FEAR RIVER, SR 1737 & SR 1739 IN FAYETTEVILLE

TIP NO. B-4091	SHEET NO. SIGN-1
APPROVED: <i>[Signature]</i>	
DATE: 5/1/12	
SEAL	

T.I.P.: B-4091

CONTRACT: C202879

01-MAY-2012 10:00 AM Traffic AT 9427515
C:\MAY\2012\0000\Quantities & GM Signs\B-4091.Sgn.SGN.secd.dgn
bnowlin

PAY ITEM NOTES

1	DISPOSAL OF SIGN SYSTEM, U-CHANNEL
2	DISPOSAL OF SIGN SYSTEM, WOOD

GENERAL NOTES

- . SIGNS FURNISHED BY STATE
- . ALL TYPE 'D' SIGNS SHALL BE MOUNTED ON TWO U-CHANNEL POSTS UNLESS OTHERWISE INDICATED ON THE PLANS.
- . IF REMOVAL OR RELOCATION OF SIGNS ON PRIVATE STREET (NON-STATE MAINTAINED) IS REQUIRED DUE TO CONSTRUCTION, THE CONTRACTOR SHALL INFORM THE ENGINEER. THE WORK WILL BE COMPLETED BY OTHERS.
- . SIGNING PLANS DO NOT INCLUDE TEMPORARY CONSTRUCTION SIGNING OR PAVEMENT MARKINGS. SEE TRAFFIC CONTROL PLANS.
- . WHEN NOT STATIONED OR DIMENSIONED ON PLANS, ALL 'E' SIGNS SHALL BE FIELD LOCATED BY THE ENGINEER
- . WHEN EXISTING SIGNS ARE REMOVED AND INSTALLED ON NEW SUPPORTS, THE RE-ERECTION SHALL IMMEDIATELY FOLLOW THE REMOVAL.
- . THE BACKGROUND FOR TYPE E SIGNS SHALL BE TYPE C REFLECTIVE SHEETING.
- . SEE ROADWAY PLANS FOR GUARD/GUIDE RAIL DETAILS.

SUMMARY OF QUANTITIES

ITEM NO.	DESC. NO.	SECT. NO.	ITEM DESCRIPTION	QUANTITY	UNIT
4072000000		903	SUPPORTS, 3 LB U-CHANNEL	534	L.F.
4096000000		904	SIGN ERECTION, TYPE D	4	EA.
4102000000		904	SIGN ERECTION, TYPE E	31	EA.
4155000000		907	DISPOSAL OF SIGN SYSTEM, U-CHANNEL	17	EA.
4158000000		907	DISPOSAL OF SIGN SYSTEM, WOOD	1	EA.

ROADWAY STANDARD DRAWING

THE FOLLOWING ROADWAY STANDARDS AS APPEAR IN "ROADWAY STANDARD DRAWINGS" - PROJECT SERVICES UNIT - N.C. DEPARTMENT OF TRANSPORTATION - RALEIGH, N.C., DATED JANUARY 2012 ARE APPLICABLE TO THIS PROJECT AND BY REFERENCE HEREBY ARE CONSIDERED A PART OF THESE PLANS:

STD. NO.	TITLE
904.10	ORIENTATION OF GROUND MOUNTED SIGNS
904.50	MOUNTING OF TYPE 'D', 'E' AND 'F' SIGNS ON 'U' CHANNEL POSTS

INDEX

SHEET NO.	DESCRIPTION
SIGN - 1	TITLE SHEET - SUMMARY OF QUANTITIES, ROADWAY STANDARD DRAWINGS, INDEX, & NOTES
SIGN - 2	TYPE "D" SIGNS
SIGN - 3	TYPE "E" SIGNS
SIGN - 4 - 5	EXISTING SIGNS DETAIL SHEETS
SIGN - 6 - 7	PROPOSED SIGNS DETAIL SHEETS

PLAN PREPARED BY: N.C.D.O.T. SIGNING AND DELINEATION UNIT

AYMAN I. ALQUDWAH, P.E.	SIGNING & DELINEATION REGIONAL ENGINEER
BARRY NOWLIN	SIGNING & DELINEATION DESIGN TECHNICIAN

TIP NO. B-4091	SHEET NO. SIGN-2
APPROVED: <i>[Signature]</i>	
DATE: 5/11/12	
SEAL	



SIGN NUMBER: 301,302 BACKG COLOR: Green
 TYPE: D COPY COLOR: White
 QUANTITY: 2

SYMBOL	X	Y	WID	HT

SIGN WIDTH: 3'-6"
 HEIGHT: 1'-6"
 TOTAL AREA: 5.3 Sq.Ft.

BORDER TYPE: FLUSH
 RECESS: 0"
 WIDTH: 0.5"
 RADII: 2"

NO. Z BARS: MAT'L: 0.125" (3.2 mm) ALUMINUM
 LENGTH:

DESIGN BY: BN CHECKED BY:
 PROJECT ID: B-4091 DIV: 06 DATE: Apr 30, 2012

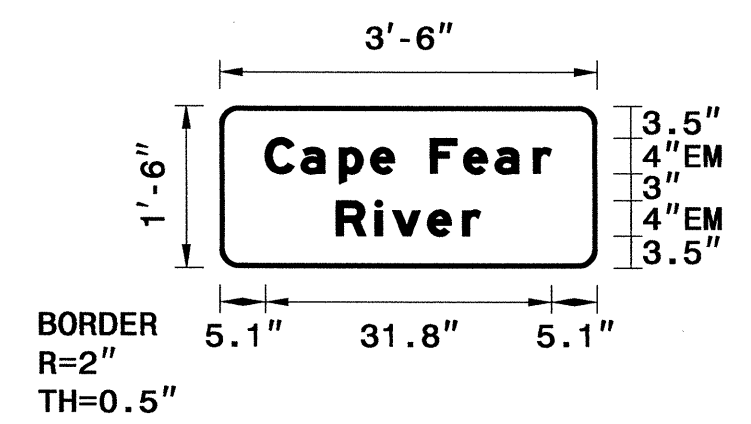

USE NOTES: 1,2

- Legend and border(except those that are colored black) shall be direct applied Grade C sheeting.
- Background shall be Grade C reflective sheeting.

Spacing Factor is 1 unless specified otherwise

LETTER POSITIONS

Letter spacings are to start of next letter

Series/Size	Text Length
EM 2000	31.8
EM 2000	16

FILENAME: B-4091_Sgn_SGN_seed NORTH CAROLINA D.O.T. SIGN DETAIL

SIGN NUMBER: 303,304 BACKG COLOR: Green
 TYPE: D COPY COLOR: White
 QUANTITY: 2

SYMBOL	X	Y	WID	HT

SIGN WIDTH: 4'-6"
 HEIGHT: 2'-6"
 TOTAL AREA: 11.3 Sq.Ft.

BORDER TYPE: FLUSH
 RECESS: 0"
 WIDTH: 0.5"
 RADII: 3"

NO. Z BARS: MAT'L: 0.125" (3.2 mm) ALUMINUM
 LENGTH:

DESIGN BY: BN CHECKED BY:
 PROJECT ID: B-4091 DIV: 06 DATE: Sep 01, 2011

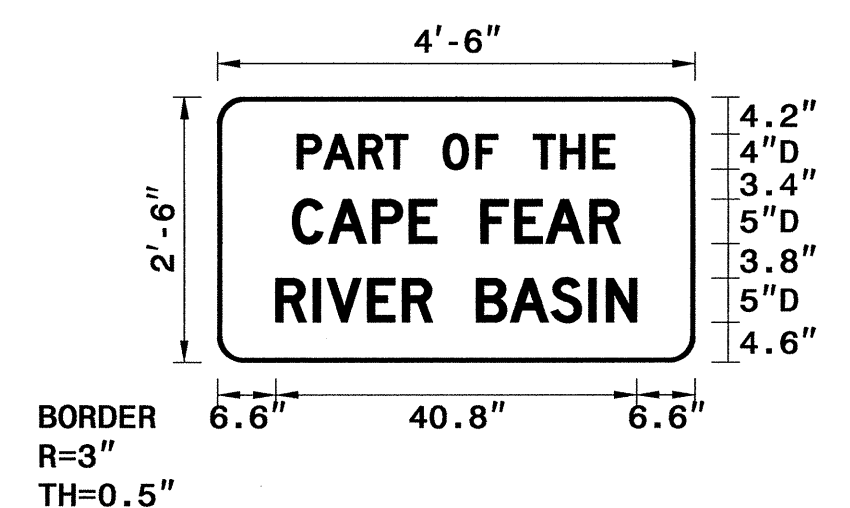

USE NOTES:

- Legend and border(except those that are colored black) shall be direct applied Grade C sheeting.
- Background shall be Grade C reflective sheeting.

Spacing Factor is 1 unless specified otherwise

LETTER POSITIONS

Letter spacings are to start of next letter

Series/Size	Text Length
D 2000	35.9
D 2000	37.1
D 2000	40.8

FILENAME: B-4091_Guidesign_English NORTH CAROLINA D.O.T. SIGN DETAIL

SIGN NUMBER: 305,306 BACKG COLOR: Green
 TYPE: D COPY COLOR: White
 QUANTITY: 2

SYMBOL	X	Y	WID	HT
AR_Type D	75	6	6	9

SIGN WIDTH: 7'-6"
 HEIGHT: 1'-6"
 TOTAL AREA: 11.3 Sq.Ft.

BORDER TYPE: FLUSH
 RECESS: 0"
 WIDTH: 0.75"
 RADII: 3"

NO. Z BARS: MAT'L: 0.125" (3.2 mm) ALUMINUM
 LENGTH:

DESIGN BY: BN CHECKED BY:
 PROJECT ID: B-4091 DIV: 06 DATE: Apr 24, 2012

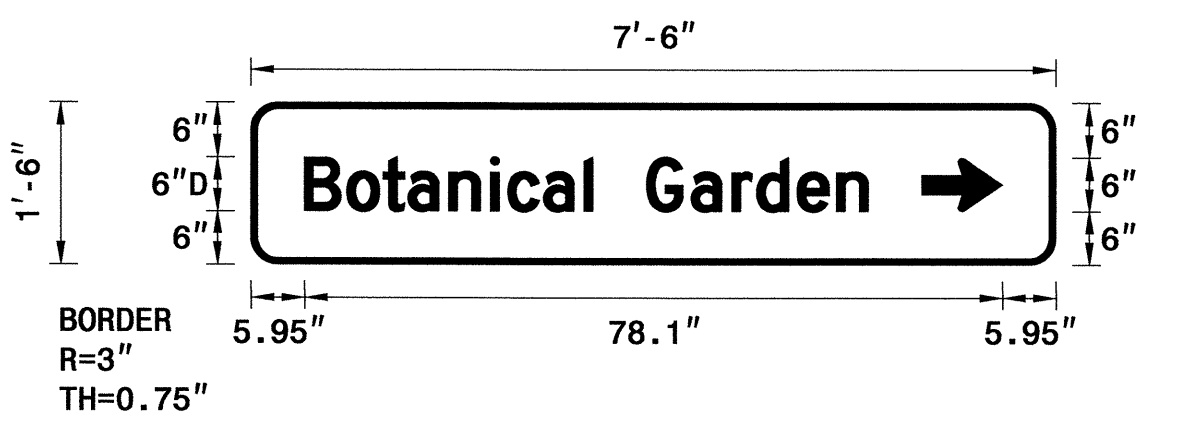

USE NOTES: 1,2

- Legend and border(except those that are colored black) shall be direct applied Grade C sheeting.
- Background shall be Grade C reflective sheeting.

Spacing Factor is 1 unless specified otherwise

LETTER POSITIONS

Letter spacings are to start of next letter

Series/Size	Text Length
D 2000	63.1

FILENAME: B-4091_Sgn_SGN_seed NORTH CAROLINA D.O.T. SIGN DETAIL

SIGN DESIGN

D:\MAY_2012_0830\Signs\B-4091\CADD\Quantities & GM Signs\B-4091_Sgn_SGN_seed.dgn
 5/11/12 10:27:51 AM
 Brown

TIP NO. B-4091	SHEET NO. SIGN 4
APPROVED: <i>Sydney [Signature]</i>	
DATE: 5/11/12	
SEAL	

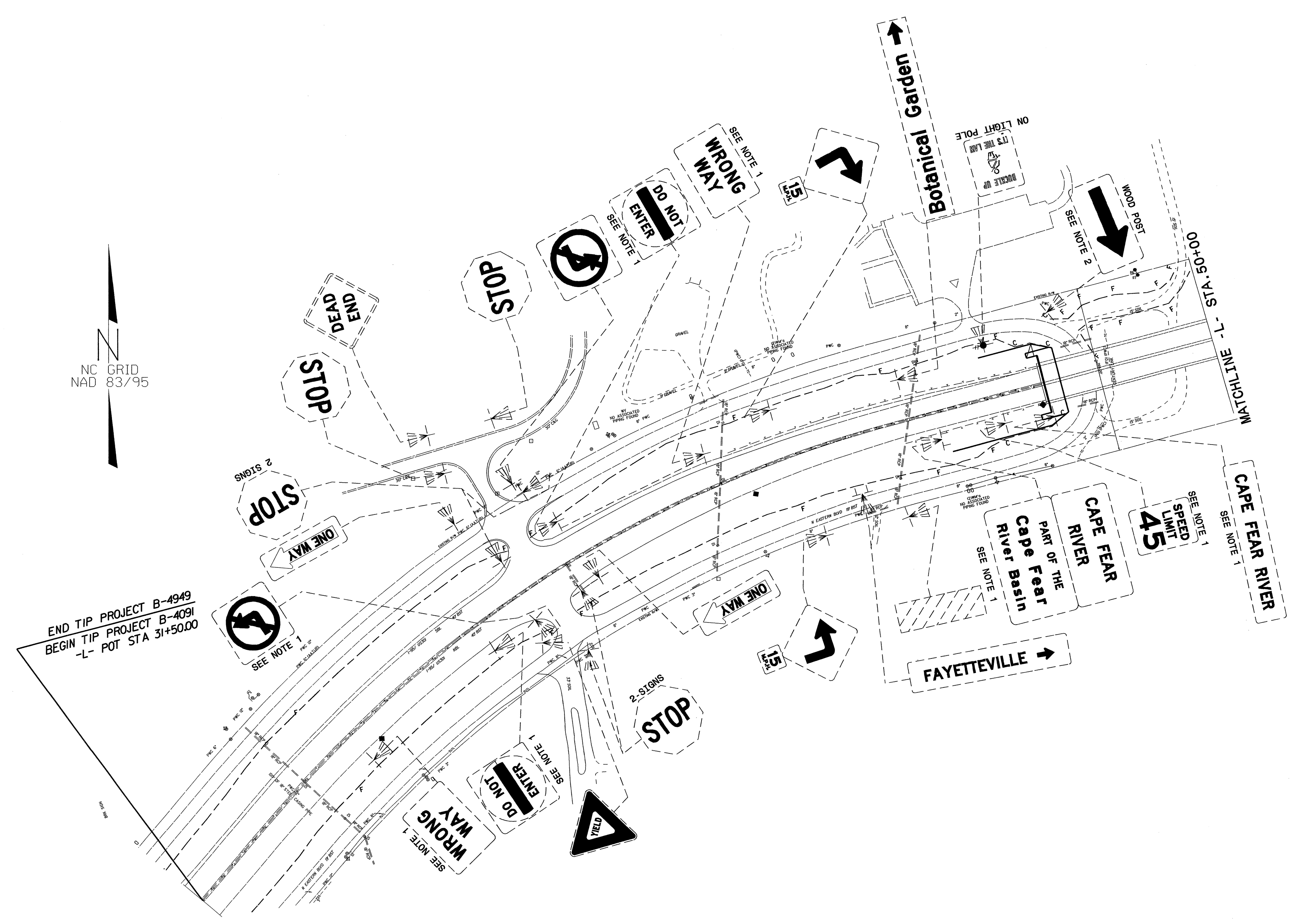

EXISTING SIGNS

01-MAY-2012 09:51
 C:\Users\p1c\Documents\CADD\Signing Layout Plans\B-4091_Sgn_Existing_Signs_2.dgn
 broulin

TIP NO. B-4091	SHEET NO. SIGN-5
APPROVED: <i>[Signature]</i>	
DATE: 5/1/12	
SEAL	

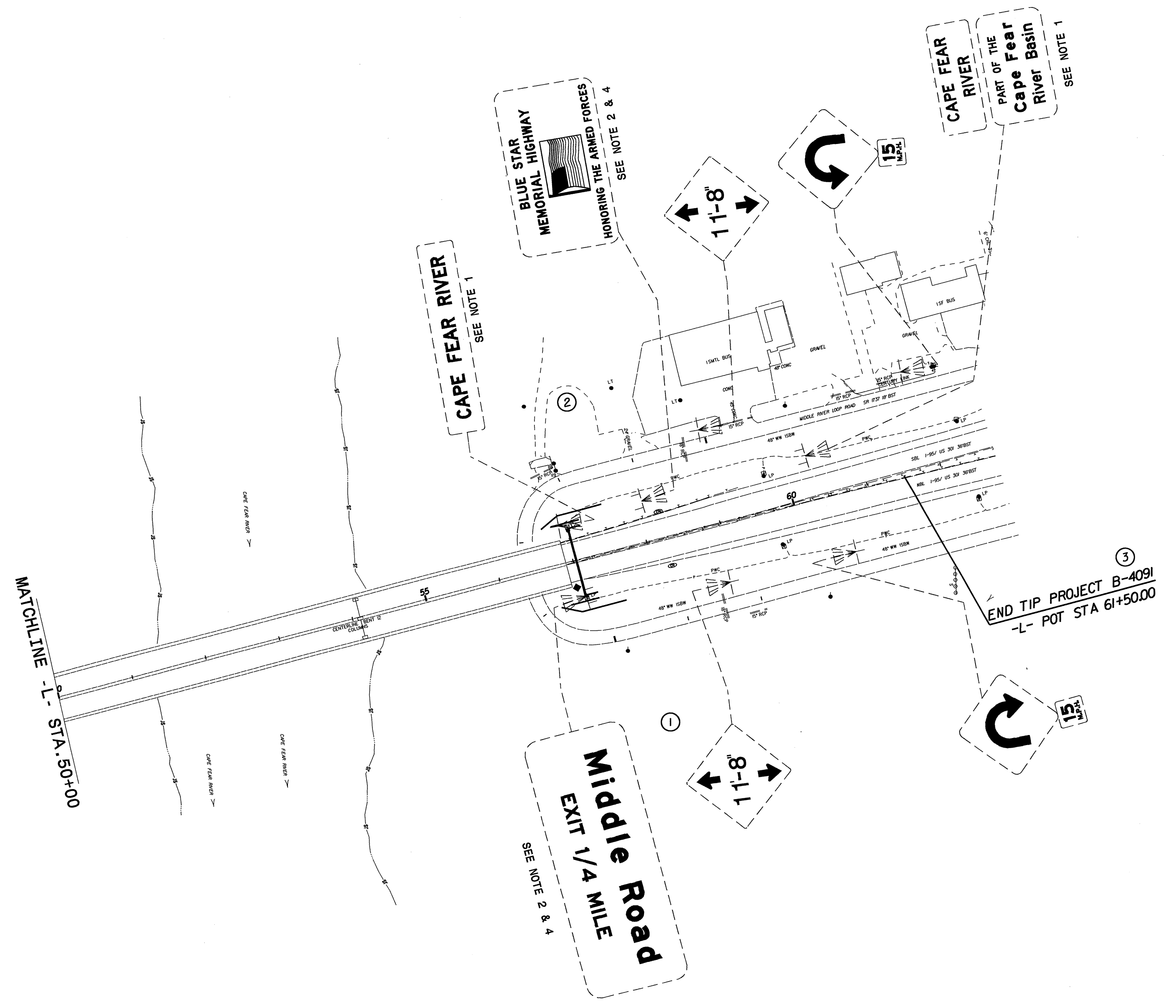

EXISTING SIGNS

25. APR 2012 14:21
 C:\p\proj\041512\B-4091\Traffic\Signing\CADD\Signing Layout Plans\B-4091_Sgn_Existing Signs_3.dgn
 browlin AT 1E27516

TIP NO. B-4091	SHEET NO. SIGN-7
APPROVED: <i>[Signature]</i>	
DATE: 5/1/12	
SEAL	

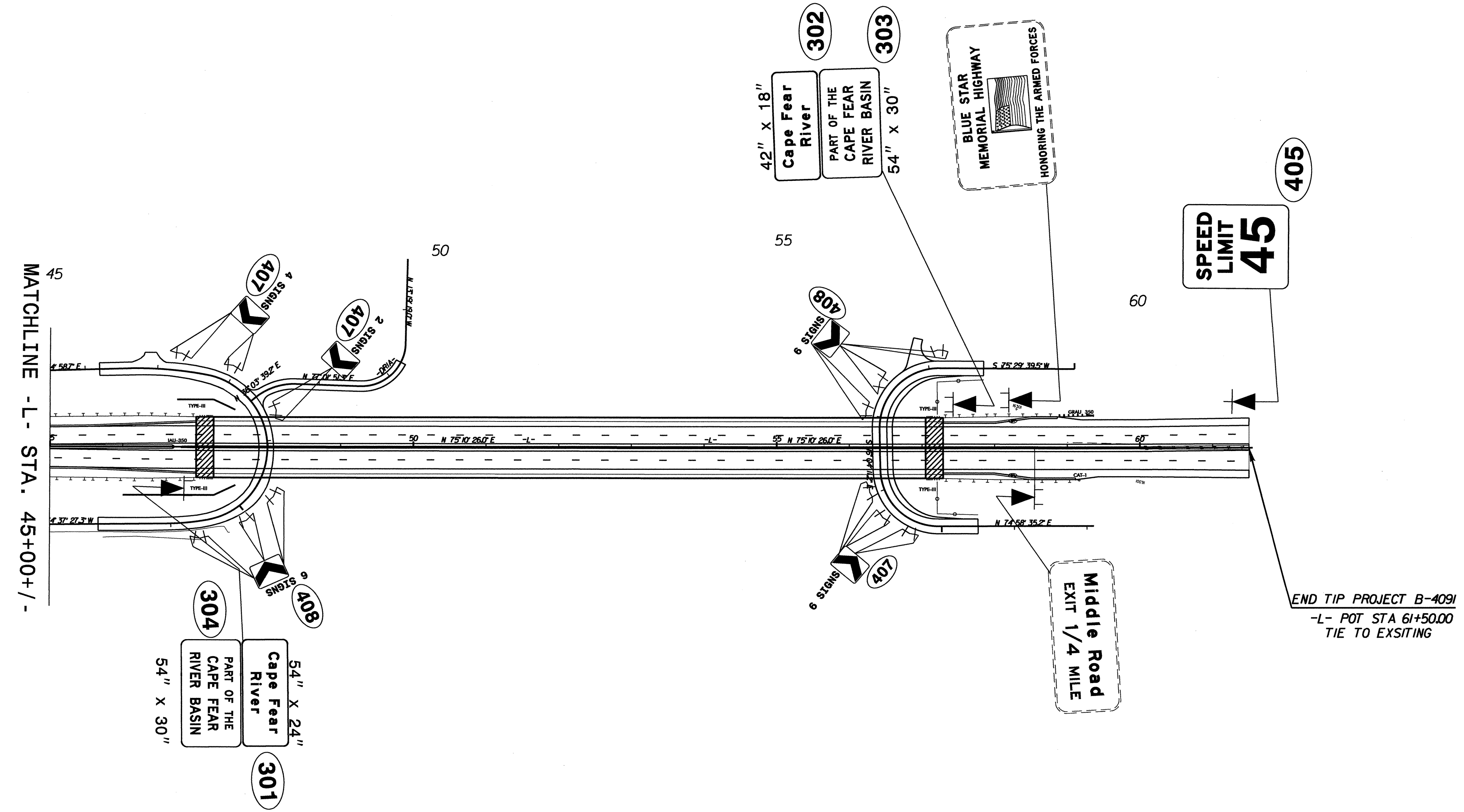

END TIP PROJECT B-4091
-L- POT STA 61+50.00
TIE TO EXSITING

PROPOSED SIGNS

20 APR 2012 17:33
 C:\Users\ibrown\Documents\CADD\Signing Layout Plans\New Sign-4 & Sign-5\B-4091_Sign_SGN.5.dgn
 ibrown