

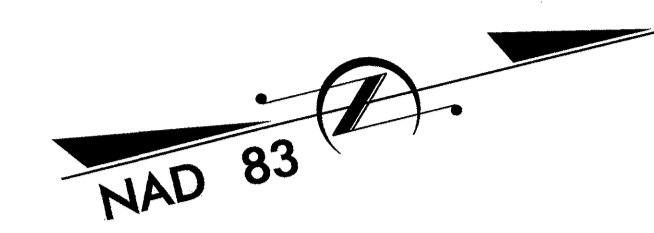

TIP NO. B-4028	SHEET NO. PMP-2
APPROVED: <i>[Signature]</i>	
DATE: 4/26/12	
SEAL	

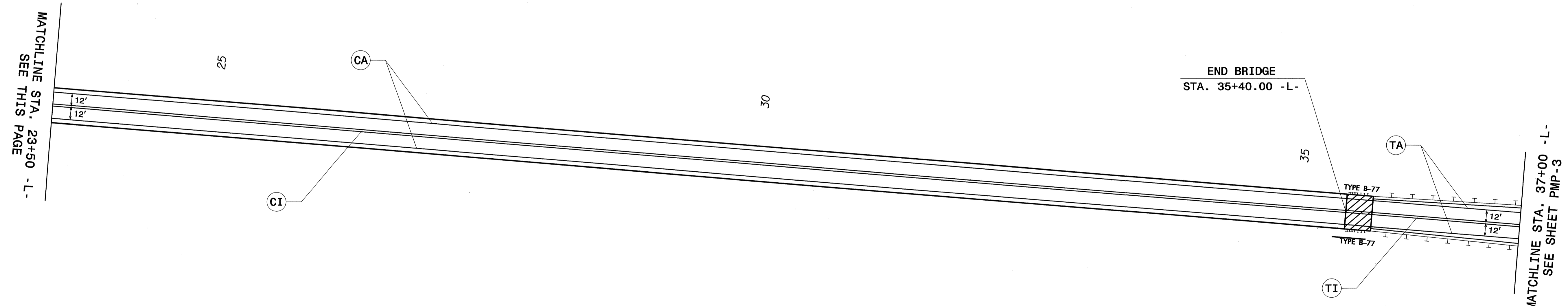

**STA. 10+50.00 -L- BEGIN TIP PROJECT B-4028**

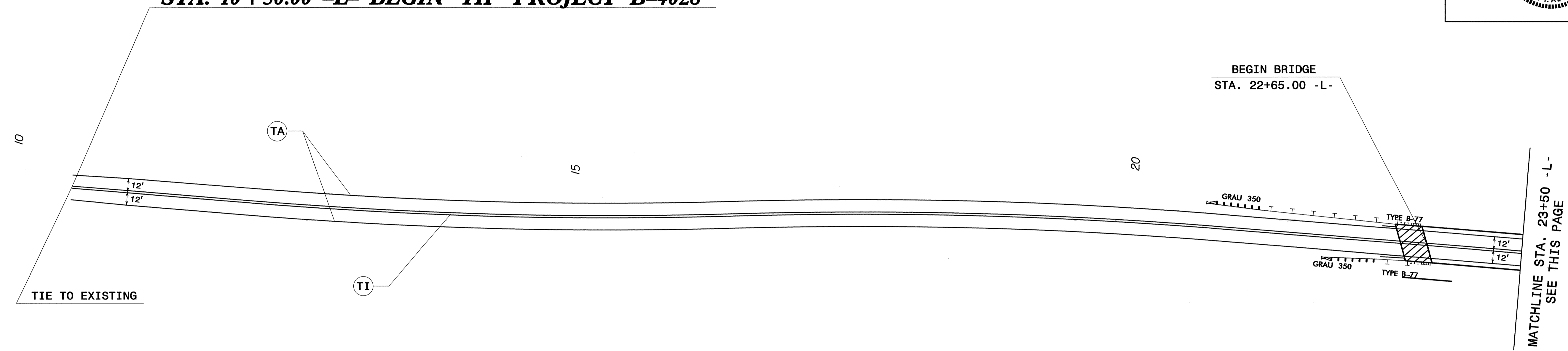

SYMBOL AND PAVEMENT MARKING LEGEND	
<b>THERMOPLASTIC</b>	<b>COLD APPLIED PLASTIC</b>
(TA) WHITE EDGE LINE (4")	(CA) WHITE EDGE LINE (4")
(TI) YELLOW DOUBLE CENTER (4")	(CI) YELLOW DOUBLE CENTER (4")

**PROPOSED PAVEMENT MARKINGS**

23-Apr-2012 12:05 PM C:\Users\meaton\Documents\Projects\B4028\Traffic\Signing\CADD\PM\B4028\BPM\psh1.dgn  
 23-Apr-2012 12:05 PM C:\Users\meaton\Documents\Projects\B4028\Traffic\Signing\CADD\PM\B4028\BPM\psh1.dgn  
 meaton

TIP NO. B-4028	SHEET NO. PMP-3
APPROVED: <i>[Signature]</i>	
DATE: 4/26/12	
SEAL	

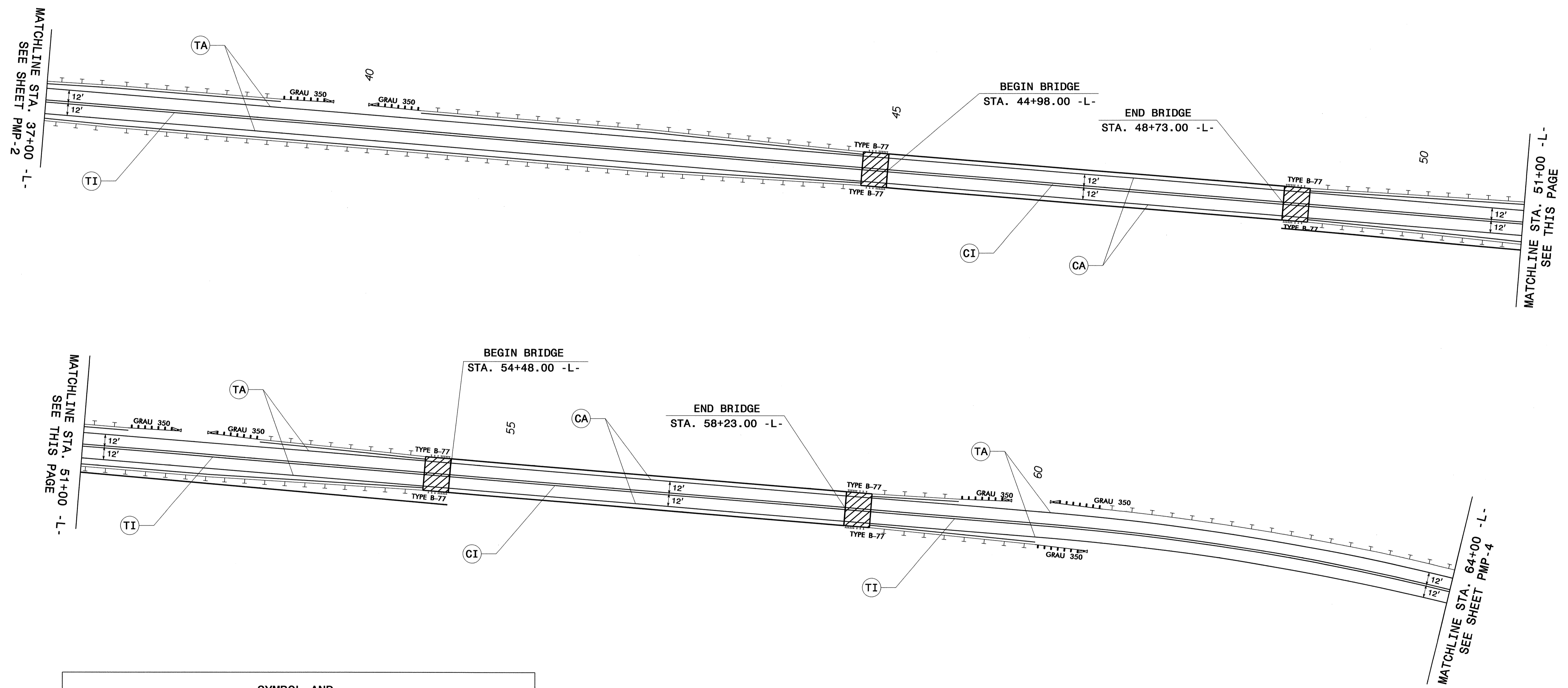
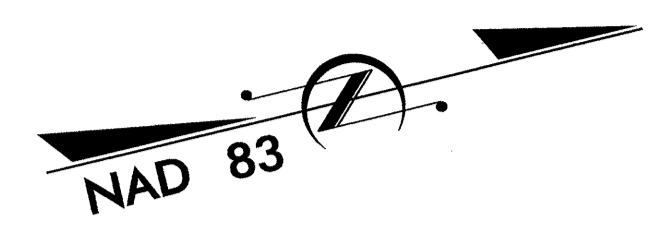

SYMBOL AND PAVEMENT MARKING LEGEND			
THERMOPLASTIC		COLD APPLIED PLASTIC	
(TA)	WHITE EDGE LINE (4")	(CA)	WHITE EDGE LINE (4")
(TI)	YELLOW DOUBLE CENTER (4")	(CI)	YELLOW DOUBLE CENTER (4")

PROPOSED PAVEMENT MARKINGS

23-APP-2012 (2:13)  
 P:\Projects\B4028\Traffic\Signing\CADD\PM\B4028\_BPMP\_psh2.dgn  
 12/27/08

TIP NO. B-4028	SHEET NO. PMP-4
APPROVED: <i>[Signature]</i>	
DATE: 4/26/12	
SEAL	

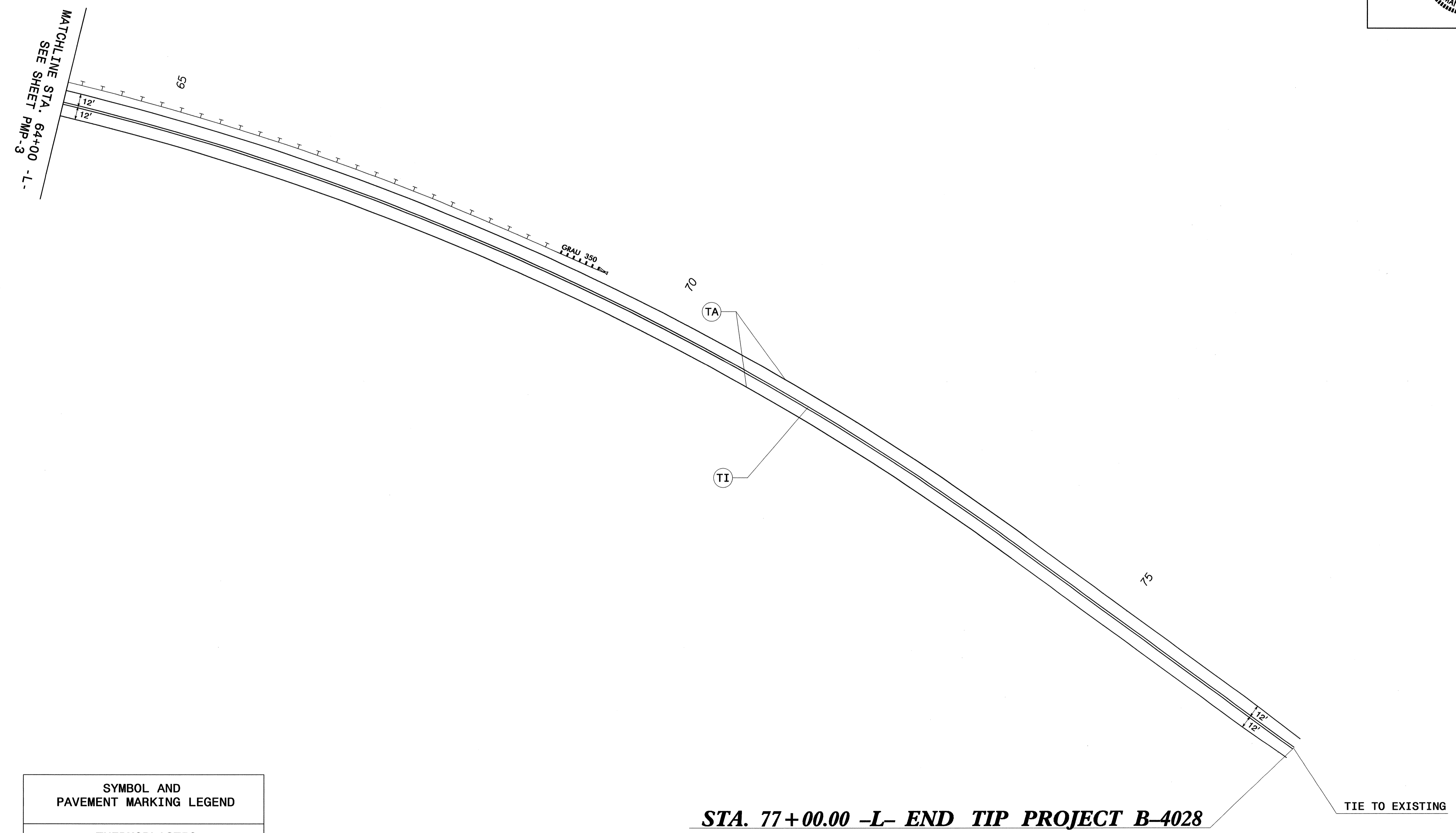
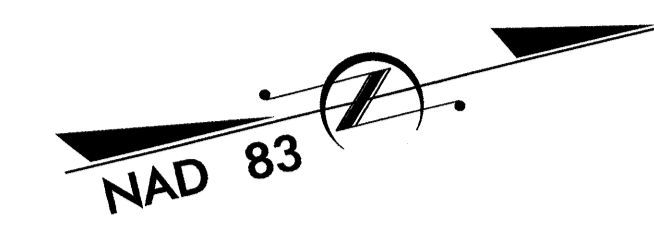

**STA. 77+00.00 -L- END TIP PROJECT B-4028**

SYMBOL AND PAVEMENT MARKING LEGEND	
<b>THERMOPLASTIC</b>	
(TA)	WHITE EDGE LINE (4")
(TI)	YELLOW DOUBLE CENTER (4")

**PROPOSED PAVEMENT MARKINGS**

23-APR-2012 12:12  
 P:\TIP-Proj\B-4028-Traffic\Signing\CADD\PMF\B-4028-BPMP-ph3.dgn  
 mason 11 12:27:08