

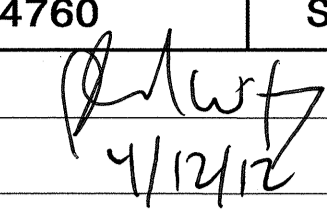

**STATE OF NORTH CAROLINA  
DEPARTMENT OF TRANSPORTATION**

|   |                     |
|---|---------------------|
| TIP NO.<br>B-4760   | SHEET NO.<br>SIGN-1 |
| APPROVED:  |                     |
| DATE: 4/12/12   |                     |
| SEAL<br>   |                     |

**SIGNING PLAN  
GUILFORD COUNTY**

LOCATION: BRIDGE NO. 77 ON SR 4053 OVER  
US 29/US 70 I-85 BUS

**T.I.P.: B-4760**  
**CONTRACT: C202846**

**GENERAL NOTES**

- . SIGNS FURNISHED BY STATE
- . ALL TYPE 'D' SIGNS SHALL BE MOUNTED ON TWO U-CHANNEL POSTS UNLESS OTHERWISE INDICATED ON THE PLANS.
- . IF REMOVAL OR RELOCATION OF SIGNS ON PRIVATE STREET (NON-STATE MAINTAINED) IS REQUIRED DUE TO CONSTRUCTION, THE CONTRACTOR SHALL INFORM THE ENGINEER. THE WORK WILL BE COMPLETED BY OTHERS.
- . SIGNING PLANS DO NOT INCLUDE TEMPORARY CONSTRUCTION SIGNING. SEE TRAFFIC CONTROL PLANS.
- . WHEN NOT STATIONED OR DIMENSIONED ON PLANS, ALL 'E' AND 'F' SIGNS SHALL BE FIELD LOCATED BY THE ENGINEER
- . ALL EXISTING SIGNS ON "U" CHANNEL POST WITHIN THE PROJECT LIMITS SHALL BE REMOVED AND DISPOSED OF UNLESS OTHERWISE NOTED ON PLANS.
- . WHEN EXISTING SIGNS ARE REMOVED AND INSTALLED ON NEW SUPPORTS, THE RE-ERECTION SHALL IMMEDIATELY FOLLOW THE REMOVAL.
- . THE BACKGROUND FOR TYPE E & F SIGNS SHALL BE TYPE C REFLECTIVE SHEETING.
- . SEE ROADWAY PLANS FOR GUARD/GUIDE RAIL DETAILS.

**SUMMARY OF QUANTITIES**

| ITEM NO.   |           | ITEM DESCRIPTION                            | QUANTITY | UNIT |
|------------|-----------|---|----------|------|
| DESC. NO.  | SECT. NO. |   |          |      |
| 4048000000 | 902       | REINFORCED CONCRETE SIGN FOUNDATION.....    | 1        | C.Y. |
| 4060000000 | 903       | SUPPORTS, BREAKAWAY STEEL BEAM.....         | 587      | LB.  |
| 4072000000 | 903       | SUPPORTS, 3 LB STEEL U-CHANNEL.....         | 608      | L.F. |
| 4096000000 | 904       | SIGN ERECTION, TYPE D.....                  | 1        | EA.  |
| 4102000000 | 904       | SIGN ERECTION, TYPE E.....                  | 18       | EA.  |
| 4108000000 | 904       | SIGN ERECTION, TYPE F.....                  | 8        | EA.  |
| 4110000000 | 904       | SIGN ERECTION, TYPE A (GROUND MOUNTED)..... | 1        | EA.  |
| 4155000000 | 907       | DISPOSAL OF SIGN SYSTEM, U-CHANNEL.....     | 20       | EA.  |
| 4158000000 | 907       | DISPOSAL OF SIGN SYSTEM, WOOD.....          | 1        | EA.  |

**ROADWAY STANDARD DRAWING**

THE FOLLOWING ROADWAY STANDARDS AS APPEAR IN "ROADWAY STANDARD DRAWINGS" - PROJECT SERVICES UNIT - N.C. DEPARTMENT OF TRANSPORTATION - RALEIGH, N.C., DATED JANUARY 2012 ARE APPLICABLE TO THIS PROJECT AND BY REFERENCE HEREBY ARE CONSIDERED A PART OF THESE PLANS:

| STD. NO. | TITLE  |
|----------|--|
| 901.10   | TYPE 'A' SIGNS   |
| 901.50   | ARROWS AND SHIELDS   |
| 901.70   | SIGN STRINGERS AND SUPPORT SPACING                               |
| 901.80   | SIGN MOUNTING DETAILS - FOR TYPE A AND TYPE B SIGNS              |
| 903.10   | GROUND MOUNTED SIGN SUPPORTS (SEE SHEET SIGN-4 FOR SHEET 2 OF 3) |
| 904.10   | ORIENTATION OF GROUND MOUNTED SIGNS                              |
| 904.50   | MOUNTING OF TYPE 'D', 'E' AND 'F' SIGNS ON 'U' CHANNEL POSTS     |

**PROJECT NOTES**

- 1 DISPOSAL OF SIGN SYSTEM, U-CHANNEL
- 2 DISPOSAL OF SIGN SYSTEM, WOOD

**INDEX**



| SHEET NO. | DESCRIPTION                              |
|-----------|--|
| SIGN-1    | TITLE SHEET AND NOTES                    |
| SIGN-2    | SUPPORT CHART, A & D SIGNS               |
| SIGN-3    | E & F SIGNS                              |
| SIGN-4    | REVISED SIGNING ROADWAY STANDARD DRAWING |
| SIGN-5-6  | SIGN DETAIL SHEETS                       |

PLAN PREPARED BY: N.C.D.O.T. SIGNING AND DELINEATION UNIT

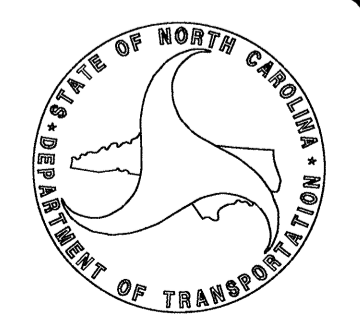
SUSAN B. KUNZ SIGNING & DELINEATION REGIONAL ENGINEER  
STACEY JOHNS SIGNING & DELINEATION DESIGN ENGINEER

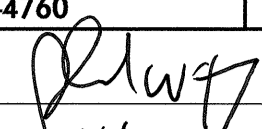

I:\APR-2012\1439 P:\TIPFProjects\B-4760\Traffic\Signing\CA00\Signing Layout\Plans\B-4760\_Sheet 1-2\_SGN.dgn s\johns A\TE247957

|   |                     |
|---|---------------------|
| TIP NO.<br>B-4760   | SHEET NO.<br>SIGN-2 |
| APPROVED:  |                     |
| DATE: 4/12/12   |                     |
| SEAL  |                     |
|            |                     |

SIGN NUMBER: 101  
TYPE: A  
QUANTITY: 1  
SIGN WIDTH: 13'-0"  
HEIGHT: 6'-6"  
TOTAL AREA: 84.5 Sq.Ft.  
BORDER TYPE: FLUSH  
RECESS: 0"  
WIDTH: 2"  
RADII: 12"  
NO. Z BARS: 2  
LENGTH: 148.0

BACKG COLOR: Green  
COPY COLOR: White

| SYMBOL    | X    | Y    | WID  | HT |
|-----------|------|------|------|----|
| AR_Type A | 64.2 | 11.2 | 22.3 | 35 |

DESIGN BY: SJOHNS  
PROJECT ID: B-4760  
CHECKED BY: SBKUNZ  
DIV: 7  
DATE: Apr 10, 2012

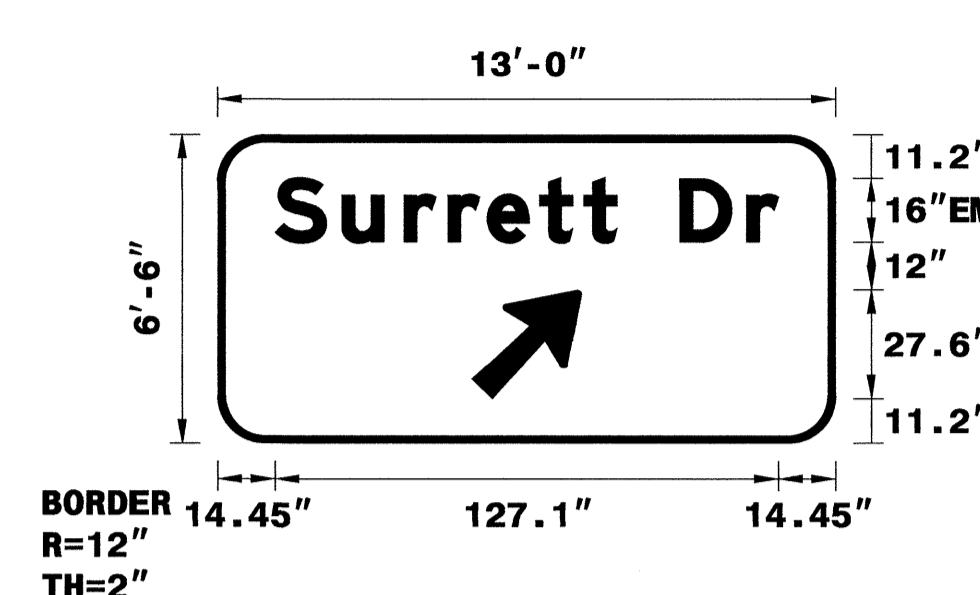

USE NOTES: 1,2,3  
1. Legend and border(except those that are colored black) shall be direct applied Grade C sheeting.  
2. Background shall be Grade C reflective sheeting.  
3. Shields; A, B, and C type arrows shall be on 0.032" (0.8mm) aluminum and demountable.

Spacing Factor is 1 unless specified otherwise

LETTER POSITIONS

Letter spacings are to start of next letter

| Series/Size | Text Length |      |      |      |     |      |      |     |    |      |   |      |  |
|-------------|-------------|------|------|------|-----|------|------|-----|----|------|---|------|--|
| EM 2000     | S           | u    | r    | r    | e   | t    | t    | D   | r  |      |   |      |  |
| 127.1       | 14.4        | 16.9 | 15.7 | 11.1 | 9.9 | 13.2 | 11.1 | 8.3 | 16 | 16.8 | 8 | 14.4 |  |

SIGN NUMBER: 301  
TYPE: D  
QUANTITY: 1  
SIGN WIDTH: 5'-0"  
HEIGHT: 1'-6"  
TOTAL AREA: 7.5 Sq.Ft.  
BORDER TYPE: FLUSH  
RECESS: 0"  
WIDTH: 0.75"  
RADII: 3"  
NO. Z BARS: 1  
LENGTH: 148.0

BACKG COLOR: Green  
COPY COLOR: White

| SYMBOL    | X   | Y | WID | HT |
|-----------|-----|---|-----|----|
| AR_Type D | 4.2 | 6 | 6   | 9  |

DESIGN BY: SJOHNS  
PROJECT ID: B-4760  
CHECKED BY: SBKUNZ  
DIV: 7  
DATE: Mar 19, 2012

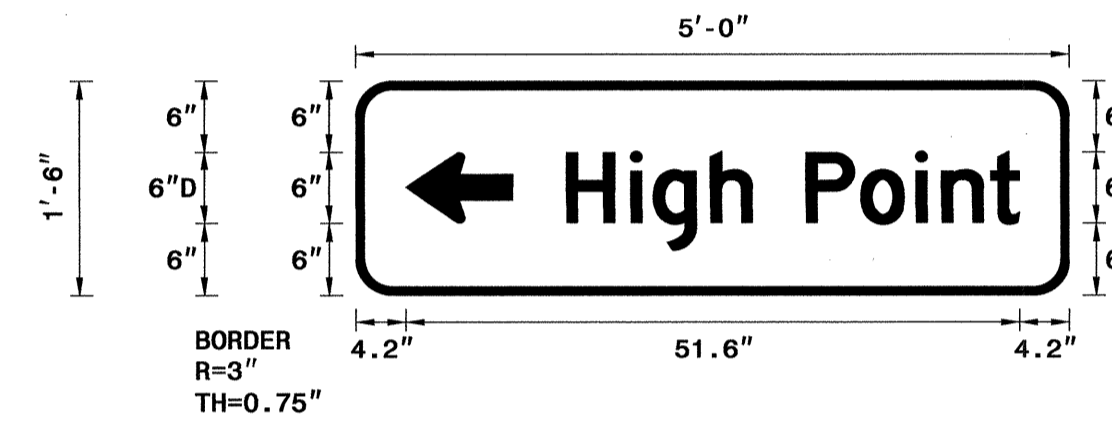

USE NOTES: 1,2  
1. Legend and border(except those that are colored black) shall be direct applied Grade C sheeting.  
2. Background shall be Grade C reflective sheeting.

Spacing Factor is 1 unless specified otherwise

LETTER POSITIONS

Letter spacings are to start of next letter

| Series/Size | Text Length |     |     |     |     |     |     |     |     |     |     |     |  |
|-------------|-------------|-----|-----|-----|-----|-----|-----|-----|-----|-----|-----|-----|--|
| D 2000      | H           | i   | g   | h   | P   | o   | i   | n   | t   |     |     |     |  |
| 38.1        | 17.7        | 5.4 | 1.9 | 4.8 | 3.5 | 4.5 | 4.6 | 4.6 | 2.2 | 4.1 | 2.4 | 4.2 |  |

### SUPPORT CHART

| SIGN NO. | SIGN TYPE | SIGN SIZE (in. w x h) | ROADWAY STATION | NO. OF SUP. | BEAM SECTION | SUPPORT TYPE BA or S | ATTACH METHOD | MOUNTING METHOD | HORIZ CLR. (ft.) | LENGTH (ft) |      |     |      | LEFT SUPPORT (ft) |       |              | CENTER SUPPORT (ft) |      |              | RIGHT SUPPORT (ft) |       |              | FOOTING DIAMETER (ft.) | FOOTING DEPTH (ft.) | B/A SUPPORT WEIGHTS (lbs.) | SIMPLE SUPPORT WEIGHTS (lbs.) | REINF. FTGS. (c.y.) | PLAIN FTGS. (c.y.) | FIELD VERIFIED SEE NOTE 2 (mm/dd/yy) |  |  |  |  |  |  |  |  |  |  |  |  |  |  |  |  |  |  |  |
|----------|-----------|-----------------------|-----------------|-------------|--------------|----------------------|---------------|-----------------|------------------|-------------|------|-----|------|-------------------|-------|--------------|---------------------|------|--------------|--------------------|-------|--------------|------------------------|---------------------|----------------------------|-------------------------------|---------------------|--------------------|--------------------------------------|--|--|--|--|--|--|--|--|--|--|--|--|--|--|--|--|--|--|--|
|          |           |                       |                 |             |              |                      |               |                 |                  | SNS         | HT   | MTG | HT   | S                 | L     | TOTAL LENGTH | S                   | L    | TOTAL LENGTH | S                  | L     | TOTAL LENGTH |                        |                     |                            |                               |                     |                    |                                      |  |  |  |  |  |  |  |  |  |  |  |  |  |  |  |  |  |  |  |
| 101      | A         | 156 X78               | 11+00 SBL       | 2           | W6x12        | BA                   | N/A           | N/A             | 30.00            | 6.50        | 7.00 | 4.5 | 2.88 | 16.38             | 20.88 | 0.00         | 0.00                | 0.00 | 2.91         | 16.41              | 20.91 | 1.5          | 5                      | 586.84              | 0.00                       | 0.65                          | 0.00                |                    |                                      |  |  |  |  |  |  |  |  |  |  |  |  |  |  |  |  |  |  |  |
|          |           |                       |                 |             |              |                      |               |                 |                  |             |      |     |      |                   |       |              |                     |      |              |                    |       | TOTAL        | TOTAL                  | TOTAL               | TOTAL                      |                               |                     |                    |                                      |  |  |  |  |  |  |  |  |  |  |  |  |  |  |  |  |  |  |  |
|          |           |                       |                 |             |              |                      |               |                 |                  |             |      |     |      |                   |       |              |                     |      |              |                    |       | 586.84       | 0.00                   | 0.65                | 0.00                       |                               |                     |                    |                                      |  |  |  |  |  |  |  |  |  |  |  |  |  |  |  |  |  |  |  |
| USE:     |           |                       |                 |             |              |                      |               |                 |                  |             |      |     |      |                   |       |              |                     |      |              |                    |       | 587          | 0                      | 1                   | 0                          |                               |                     |                    |                                      |  |  |  |  |  |  |  |  |  |  |  |  |  |  |  |  |  |  |  |

### SUPPORT CHART, TYPE "A" & "D" SIGNS

I:\APR-2012\1431\Projects\Traffic\Signing\CADD\Signing\_Layout\Plans\B-4760\_Sheet 1-2-50N.dgn

APPROVED: *PLW*  
DATE: *4/12/12*

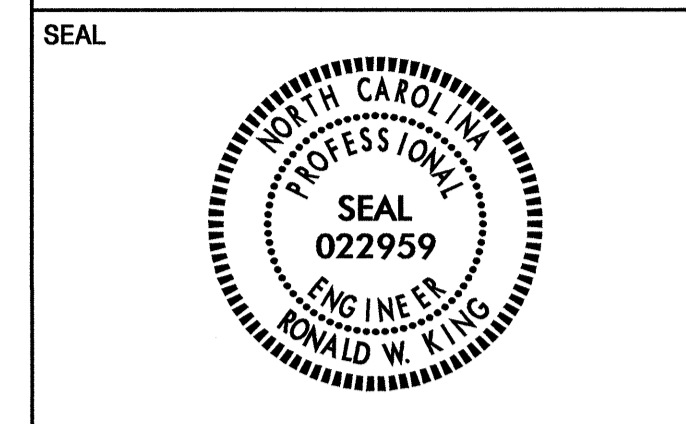

401 QUANTITY REQ'D 4

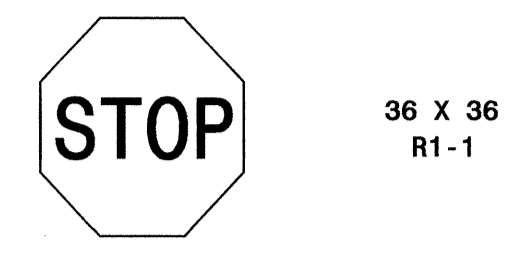

ONE "U" POST PER SIGN

406 QUANTITY REQ'D 1

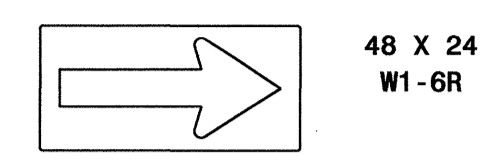

TWO "U" POSTS PER SIGN

501 505

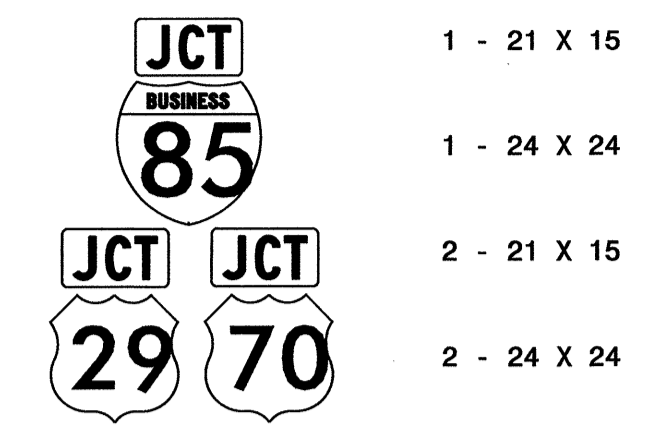

TWO "U" POSTS PER SIGN

507

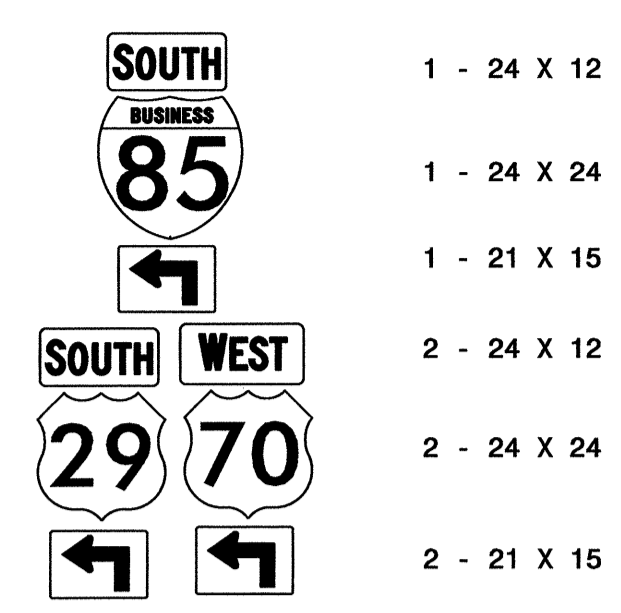

TWO "U" POSTS PER SIGN

402 QUANTITY REQ'D 4

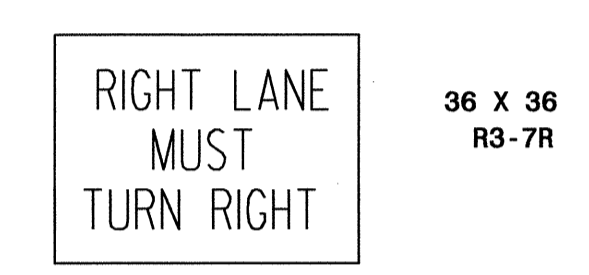

ONE "U" POST PER SIGN

407 QUANTITY REQ'D 1

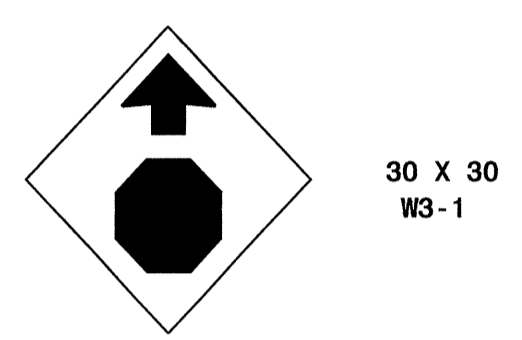

ONE "U" POST PER SIGN

502

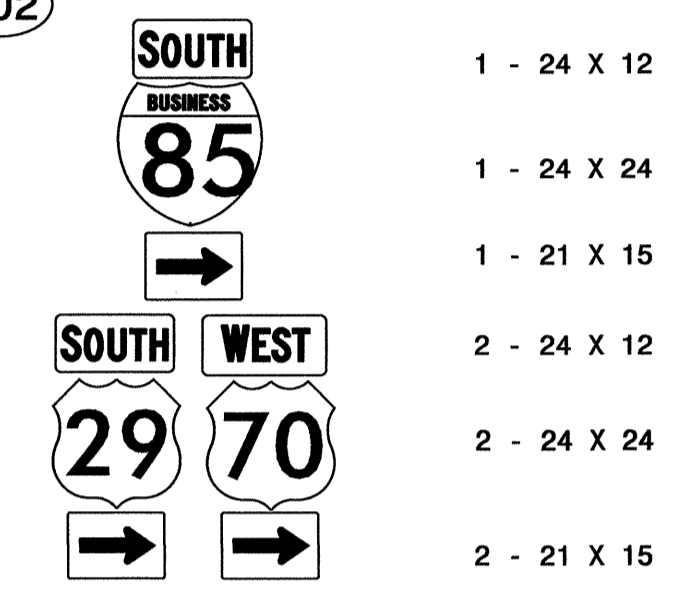

TWO "U" POSTS PER SIGN

508

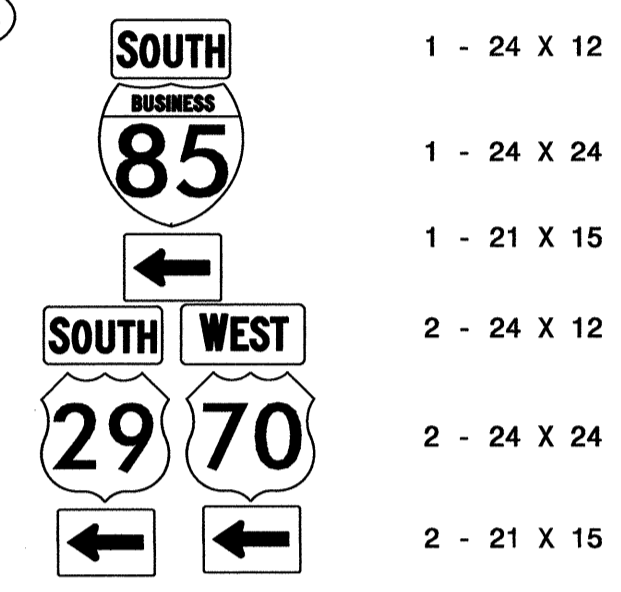

TWO "U" POSTS PER SIGN

403 QUANTITY REQ'D 2

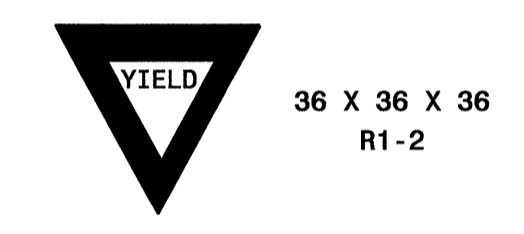

ONE "U" POST PER SIGN

503

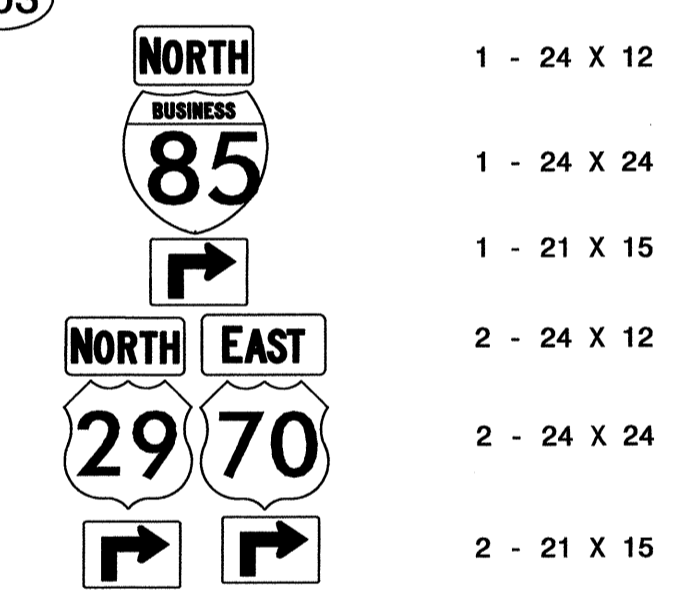

TWO "U" POSTS PER SIGN

404 QUANTITY REQ'D 5

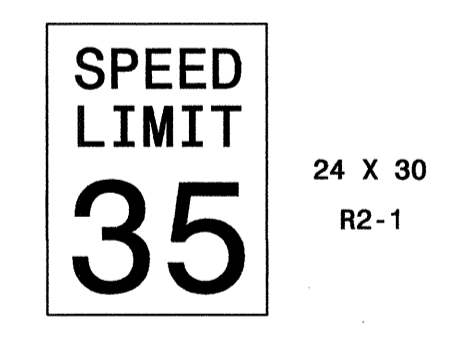

ONE "U" POST PER SIGN

504

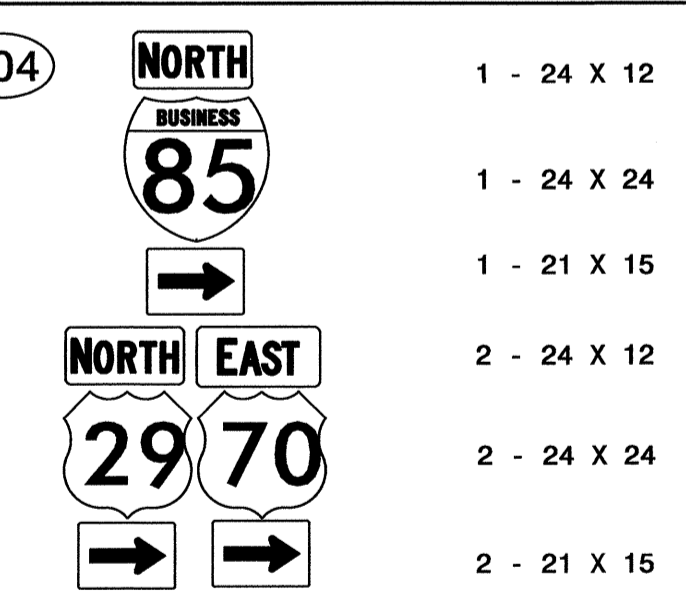

TWO "U" POSTS PER SIGN

405 QUANTITY REQ'D 1

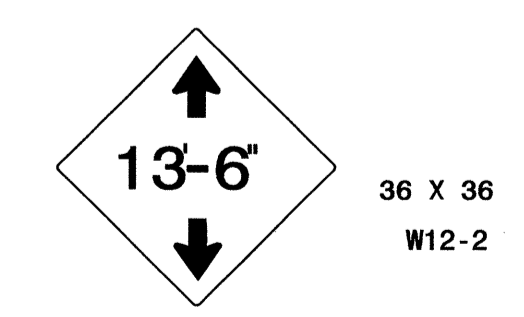

ONE "U" POST PER SIGN

506

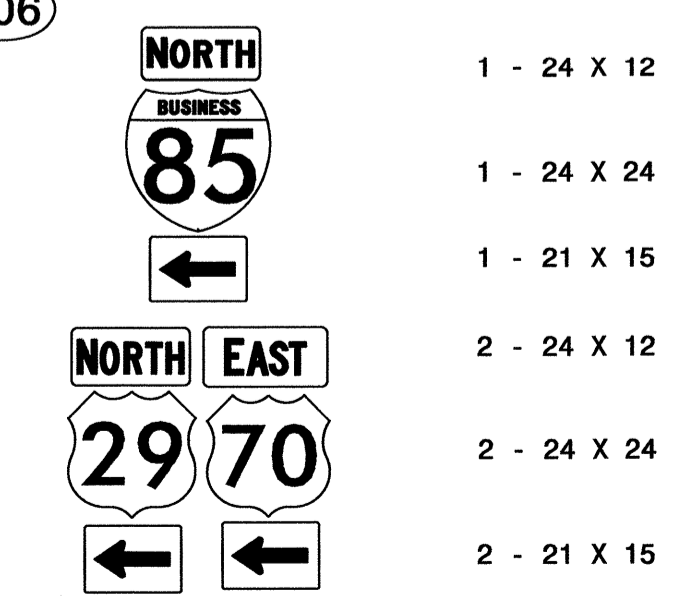

TWO "U" POSTS PER SIGN

TYPE "E" or "F" SIGNS

I:\APR-2012\1430 P:\TIP\Projects\B4760\Traffic\Signing\CADD\Signing Layout Plans\B-4760\_Sheet 1-2\_SGN.dgn s.johns RA 1E247957

|   |           |
|---|-----------|
| TIP NO.   | SHEET NO. |
| B-4760  | SIGN-4    |
| APPROVED: <i>RWT</i>  |           |
| DATE: 3/8/12  |           |
| SEAL  |           |
|  |           |

STATE OF NORTH CAROLINA  
 DEPT. OF TRANSPORTATION  
 DIVISION OF HIGHWAYS  
 RALEIGH, N.C.

ENGLISH DETAIL DRAWING FOR  
**GROUND MOUNTED SIGN SUPPORTS**  
 SHEET 2 OF 3  
**903D10**

| BEAM SHAPE | SLIP BASE PLATE DATA |                |                |                |                |                |                | KEEPER PLATE DATA |                |                |                |                |                |                | HINGE CONNECTION DATA |                    |        |        |        |        |        | BREAK AWAY SUPPORT WEIGHT CONSTANT LBS. |        |         |                |                |
|------------|----------------------|----------------|----------------|----------------|----------------|----------------|----------------|-------------------|----------------|----------------|----------------|----------------|----------------|----------------|-----------------------|--------------------|--------|--------|--------|--------|--------|---|--------|---------|----------------|----------------|
|            | BOLT SIZE            | A <sub>1</sub> | B <sub>1</sub> | C <sub>1</sub> | D <sub>1</sub> | E <sub>1</sub> | T <sub>1</sub> | R <sub>1</sub>    | A <sub>2</sub> | B <sub>2</sub> | C <sub>2</sub> | D <sub>2</sub> | E <sub>2</sub> | R <sub>2</sub> | T <sub>2</sub>        | BOLT SIZE          | F      | G      | H      | I      | J      |   | K      | L       | R <sub>3</sub> | T <sub>3</sub> |
| S3X5.7     | 1/2" DIA. X 3"       | 7"             | 4"             | 1"             | 3/4"           | 2 1/2"         | 1"             | 3/32"             | 7"             | 4"             | 1"             | 3/4"           | 2 1/2"         | 3/32"          | 28 GAUGE              | 1/2" DIA. X 1 1/4" | 2 1/4" | 3 1/2" | 4"     | 1 1/2" | 1"     | 1 1/2"                                  | 2"     | 3/32"   | 3/8"           | 18             |
| S4X7.7     | 1/2" DIA. X 3"       | 8"             | 4"             | 1"             | 3/4"           | 2 1/2"         | 1"             | 3/32"             | 8"             | 4"             | 1"             | 3/4"           | 2 1/2"         | 3/32"          | 28 GAUGE              | 1/2" DIA. X 1 1/4" | 2 5/8" | 3 1/2" | 4"     | 1 1/2" | 1"     | 1 1/2"                                  | 2"     | 3/32"   | 3/8"           | 20             |
| W6X9       | 1/2" DIA. X 3"       | 10"            | 5"             | 1"             | 3/4"           | 3 1/2"         | 1"             | 3/32"             | 10"            | 5"             | 1"             | 3/4"           | 3 1/2"         | 3/32"          | 28 GAUGE              | 1/2" DIA. X 1 1/4" | 4"     | 3 1/2" | 4"     | 3/4"   | 1"     | 1 1/2"                                  | 2"     | 3/32"   | 3/8"           | 32             |
| W6X12      | 5/8" DIA. X 3 3/4"   | 11"            | 5"             | 1 1/4"         | 7/8"           | 3 1/4"         | 1 1/4"         | 1 1/32"           | 11"            | 5"             | 1 1/4"         | 7/8"           | 3 1/4"         | 1 1/32"        | 28 GAUGE              | 5/8" DIA. X 2 1/4" | 4"     | 4"     | 4 1/2" | 3/4"   | 1 1/8" | 5/8"                                    | 2 1/4" | 1 1/32" | 3/8"           | 39             |
| W6X16      | 5/8" DIA. X 3 3/4"   | 12"            | 6"             | 1 1/4"         | 7/8"           | 4 1/4"         | 1 1/2"         | 1 1/32"           | 12"            | 6"             | 1 1/4"         | 7/8"           | 4 1/4"         | 1 1/32"        | 28 GAUGE              | 5/8" DIA. X 2 1/2" | 4"     | 4"     | 4 1/2" | 3/4"   | 1 1/8" | 5/8"                                    | 2 1/4" | 1 1/32" | 1/2"           | 47             |
| W8X18      | 5/8" DIA. X 4 1/4"   | 13 1/2"        | 6 1/2"         | 1 1/4"         | 7/8"           | 4 3/4"         | 1 1/2"         | 1 1/32"           | 13 1/2"        | 6 1/2"         | 1 1/4"         | 7/8"           | 4 3/4"         | 1 1/32"        | 28 GAUGE              | 5/8" DIA. X 2 1/2" | 5 1/4" | 4"     | 4 1/2" | 1"     | 1 1/8" | 5/8"                                    | 2 1/4" | 1 1/32" | 1/2"           | 70             |
| W8X21      | 3/4" DIA. X 4 1/4"   | 14"            | 7"             | 1 1/2"         | 1"             | 5"             | 1 1/2"         | 1 1/32"           | 14"            | 7"             | 1 1/2"         | 1"             | 5"             | 1 1/32"        | 28 GAUGE              | 3/4" DIA. X 2 3/4" | 5 1/4" | 6"     | 7"     | 1"     | 1 3/4" | 3/4"                                    | 3 1/2" | 1 1/32" | 1/2"           | 73             |
| W10X22     | 3/4" DIA. X 4 1/4"   | 16"            | 8"             | 1 1/2"         | 1"             | 6"             | 1 1/2"         | 1 1/32"           | 16"            | 8"             | 1 1/2"         | 1"             | 6"             | 1 1/32"        | 28 GAUGE              | 3/4" DIA. X 2 3/4" | 5 3/4" | 6"     | 7"     | 1"     | 1 3/4" | 3/4"                                    | 3 1/2" | 1 1/32" | 1/2"           | 119            |
| W10X26     | 3/4" DIA. X 4 3/4"   | 16 1/2"        | 8"             | 1 1/2"         | 1"             | 6"             | 1 3/4"         | 1 1/32"           | 16 1/2"        | 8"             | 1 1/2"         | 1"             | 6"             | 1 1/32"        | 28 GAUGE              | 3/4" DIA. X 2 3/4" | 5 3/4" | 6"     | 7"     | 1"     | 1 3/4" | 3/4"                                    | 3 1/2" | 1 1/32" | 5/8"           | 140            |
| W12X26     | 3/4" DIA. X 4 3/4"   | 18 1/2"        | 9"             | 1 1/2"         | 1"             | 7"             | 1 3/4"         | 1 1/32"           | 18 1/2"        | 9"             | 1 1/2"         | 1"             | 7"             | 1 1/32"        | 28 GAUGE              | 3/4" DIA. X 2 3/4" | 6 1/2" | 6"     | 7"     | 1"     | 1 3/4" | 3/4"                                    | 3 1/2" | 1 1/32" | 5/8"           | 176            |
| W14X30     | 1" DIA. X 5"         | 22"            | 9"             | 2"             | 1 1/2"         | 6"             | 2"             | 1 1/32"           | 22"            | 9"             | 2"             | 1 1/2"         | 6"             | 1 1/32"        | 28 GAUGE              | 1" DIA. X 3"       | 6 3/4" | 7"     | 8"     | 1 1/4" | 2"     | 1"                                      | 4"     | 1 1/32" | 5/8"           | 205            |
| W16X31     | 1" DIA. X 5"         | 24"            | 9"             | 2"             | 1 1/2"         | 6"             | 2"             | 1 1/32"           | 24"            | 9"             | 2"             | 1 1/2"         | 6"             | 1 1/32"        | 28 GAUGE              | 1" DIA. X 3 1/4"   | 5 1/2" | 7"     | 8"     | 1 1/4" | 2"     | 1"                                      | 4"     | 1 1/32" | 3/4"           | 223            |
| W18X35     | 1" DIA. X 5"         | 25"            | 9"             | 2"             | 1 1/2"         | 6"             | 2"             | 1 1/32"           | 25"            | 9"             | 2"             | 1 1/2"         | 6"             | 1 1/32"        | 28 GAUGE              | 1" DIA. X 3 1/4"   | 6"     | 7"     | 8"     | 1 1/4" | 2"     | 1"                                      | 4"     | 1 1/32" | 3/4"           | 243            |
| W18X40     | 1" DIA. X 5 1/2"     | 26"            | 9"             | 2"             | 1 1/2"         | 6"             | 2 1/4"         | 1 1/32"           | 26"            | 9"             | 2"             | 1 1/2"         | 6"             | 1 1/32"        | 28 GAUGE              | 1" DIA. X 3 3/4"   | 6"     | 7"     | 8"     | 1 1/4" | 2"     | 1"                                      | 4"     | 1 1/32" | 7/8"           | 278            |
| W21X44     | 1" DIA. X 5 1/2"     | 29"            | 9"             | 2"             | 1 1/2"         | 6"             | 2 1/2"         | 1 1/32"           | 29"            | 9"             | 2"             | 1 1/2"         | 6"             | 1 1/32"        | 28 GAUGE              | 1" DIA. X 3 3/4"   | 6 1/2" | 7"     | 8"     | 1 1/4" | 2"     | 1"                                      | 4"     | 1 1/32" | 7/8"           | 310            |

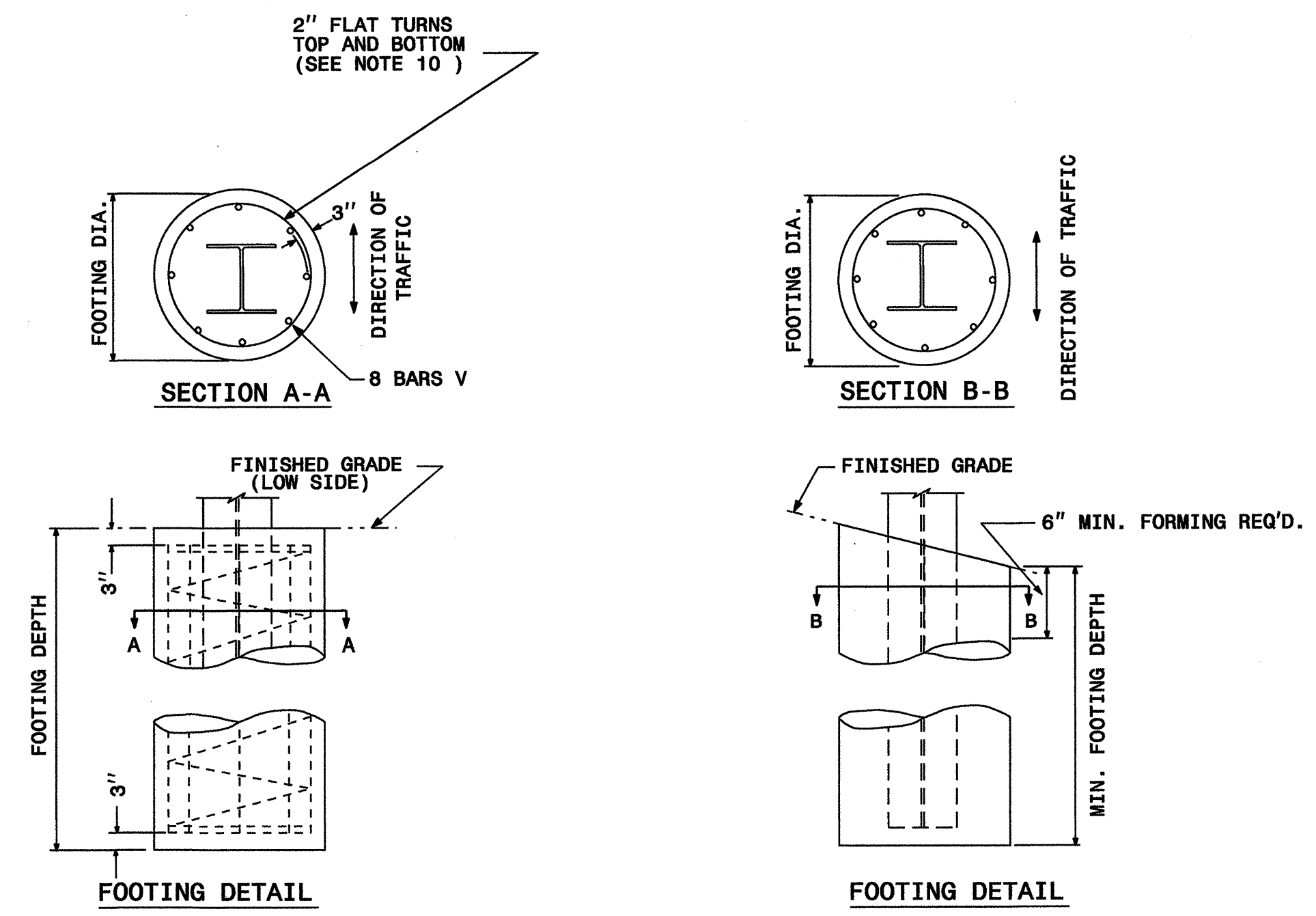

| FOUNDATION DATA * |               |                  |
|-------------------|---------------|------------------|
| FOOTING DIAMETER  | REINFORCEMENT | SPIRAL BAR       |
| 1' 6"             | 8 # 6 BARS    | #3 BAR, 6" PITCH |
| 2'                | 8 # 7 BARS    | #3 BAR, 6" PITCH |
| 2' 6"             | 8 # 9 BARS    | #3 BAR, 6" PITCH |
| 3'                | 8 # 11 BARS   | #3 BAR, 6" PITCH |
| 3' 6"             | 8 # 12 BARS   | #3 BAR, 6" PITCH |
| 4'                | 8 # 14 BARS   | #3 BAR, 6" PITCH |

\* FOUNDATION DIMENSIONS ARE SHOWN IN PLANS

STATE OF NORTH CAROLINA  
 DEPT. OF TRANSPORTATION  
 DIVISION OF HIGHWAYS  
 RALEIGH, N.C.

ENGLISH DETAIL DRAWING FOR  
**GROUND MOUNTED SIGN SUPPORTS**  
 SHEET 2 OF 3  
**903D10**

**REVISED SIGNING  
 ROADWAY STANDARD DRAWING**

08-MAR-2012 11:03:53 AM C:\pmp\2012 Standard Drawings\Standard Dwg 8-17-11\Revised\0903D10\_sgn\_sht102.dgn support...\_Revised...Sealed.dgn  
 12244745

|   |                     |
|---|---------------------|
| TIP NO.<br>B-4760   | SHEET NO.<br>SIGN-5 |
| APPROVED: <i>RWT</i>  |                     |
| DATE: <i>4/12/12</i>  |                     |
| SEAL  |                     |
|  |                     |

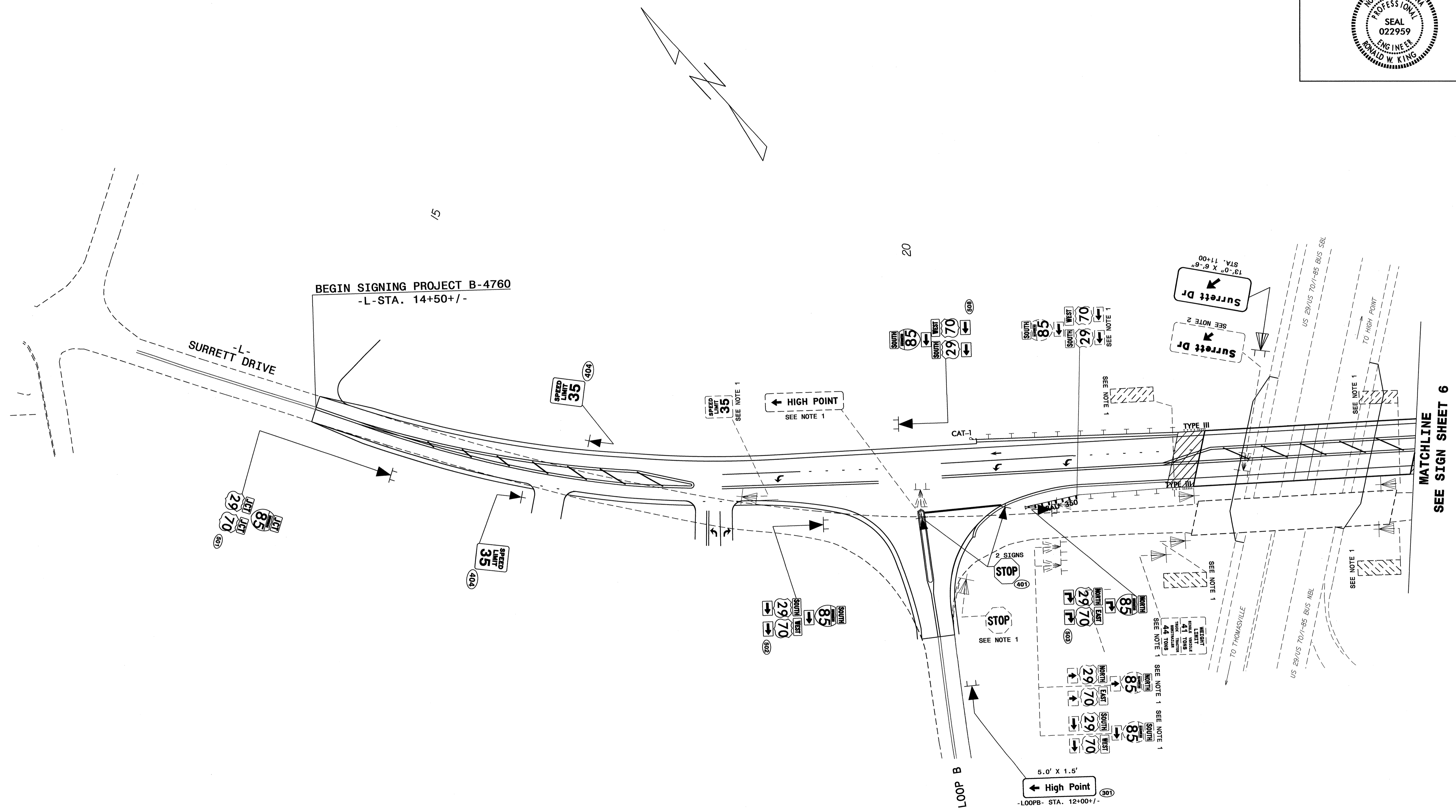

**EXISTING and PROPOSED SIGNS  
SR 4053 SURRETT DR.**

I:\APR-2012\14437  
 P:\TIPF-projects\B4760\Traffic\Signing\Layout Plans\B-4760\_Sheet 3\_SGN.dgn  
 s.johns - 4/12/12

|                              |                     |
|------------------------------|---------------------|
| TIP NO.<br>B-4760            | SHEET NO.<br>SIGN-6 |
| APPROVED: <i>[Signature]</i> |                     |
| DATE: 4/12/12                |                     |
| SEAL                         |                     |
|                              |                     |

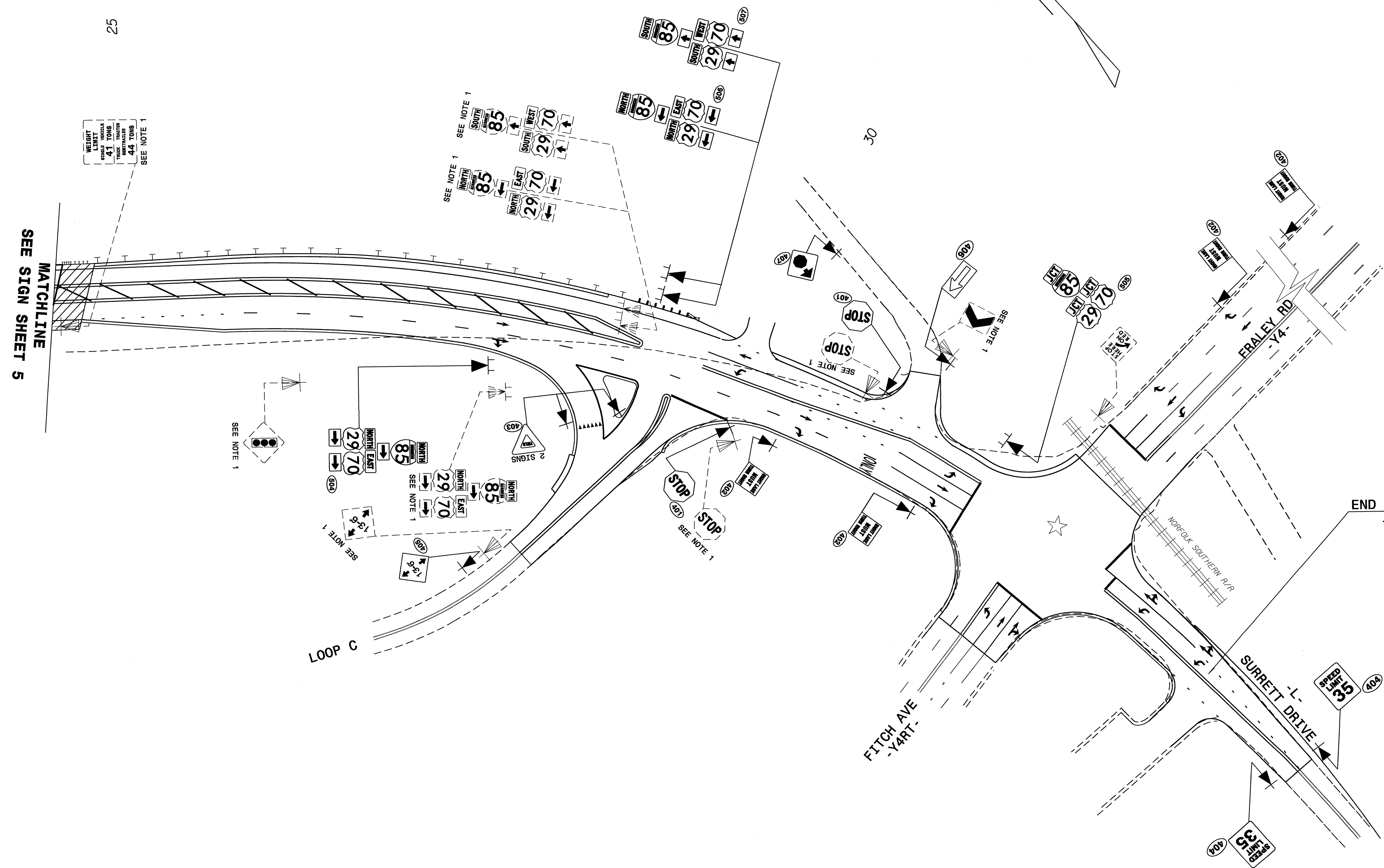

END SIGNING PROJECT B-4760  
-L- STA. 34+00+/-

**EXISTING and PROPOSED SIGNS**  
SR 4053 SURRETT DRIVE

I:\APR-2012\1436  
P:\TIPF\project\B-4760\Traffic\Signing\CADD\Signing\_Layout\Plans\B-4760\_Sheet 4\_SON.dgn  
s.johns 11/24/11