

T.I.P.: R-2719AA

CONTRACT: C202961

**STATE OF NORTH CAROLINA
DEPARTMENT OF TRANSPORTATION**

**SIGNING PLANS
LENOIR COUNTY**

LOCATION: CRESCENT RD. IN KINSTON FROM US 70 TO US 258

TIP NO. R-2719AA	SHEET NO. SIGN-1
APPROVED:	
DATE: 2/2/12	
SEAL	

ROADWAY STANDARD DRAWING

THE FOLLOWING ROADWAY STANDARDS AS APPEAR IN "ROADWAY STANDARD DRAWINGS" - PROJECT SERVICES UNIT - N.C. DEPARTMENT OF TRANSPORTATION - RALEIGH, N.C., DATED JANUARY 2012 ARE APPLICABLE TO THIS PROJECT AND BY REFERENCE HEREBY ARE CONSIDERED A PART OF THESE PLANS:

STD. NO.	TITLE
901.10	TYPE 'A' SIGNS
901.20	TYPE 'B' SIGNS
901.50	ARROWS AND SHIELDS
901.70	SIGN STRINGERS AND SUPPORT SPACING
901.80	SIGN MOUNTING DETAILS - FOR TYPE A AND TYPE B SIGNS
903.10	GROUND MOUNTED SIGN SUPPORTS
903.20	WOOD SIGN SUPPORTS
904.10	ORIENTATION OF GROUND MOUNTED SIGNS
904.20	SECONDARY SIGN MOUNTING
904.30	SUPPLEMENTAL SIGN MOUNTING
904.50	MOUNTING OF TYPE 'D', 'E' AND 'F' SIGNS ON 'U' CHANNEL POSTS

GENERAL NOTES

- . SIGNS FURNISHED BY STATE
- . ALL TYPE 'D' SIGNS SHALL BE MOUNTED ON TWO U-CHANNEL POSTS UNLESS OTHERWISE INDICATED ON THE PLANS.
- . IF REMOVAL OR RELOCATION OF SIGNS ON PRIVATE STREET (NON-STATE MAINTAINED) IS REQUIRED DUE TO CONSTRUCTION, THE CONTRACTOR SHALL INFORM THE ENGINEER. THE WORK WILL BE COMPLETED BY OTHERS.
- . WHEN NOT STATIONED OR DIMENSIONED ON PLANS, ALL 'E' AND 'F' SIGNS SHALL BE FIELD LOCATED BY THE ENGINEER
- . THE BACKGROUND FOR TYPE E & F SIGNS SHALL BE TYPE C REFLECTIVE SHEETING.
- . DO NOT BEGIN FABRICATION FOR TYPES A & B SIGNS MOUNTED ON OVERHEAD STRUCTURES OR STEEL SUPPORTS UNTIL "S" DIMENSIONS HAVE BEEN FIELD VERIFIED.
- . SEE ROADWAY PLANS FOR GUARD/GUIDE RAIL DETAILS.

SUMMARY OF QUANTITIES

ITEM NO.	ITEM DESCRIPTION		QUANTITY	UNIT
DESC. NO.	SECT. NO.			
4048000000	902	REINFORCED CONCRETE SIGN FOUNDATION.....	17	C.Y.
4057000000	SP	OVERHEAD FOOTING.....	75	C.Y.
4060000000	903	SUPPORTS, BREAKAWAY STEEL BEAM.....	11511	LB.
4082000000	903	SUPPORTS, WOOD.....	2649	L.F.
4082100000	SP	SUPPORTS, OVERHEAD SIGN STRUCTURE AT STATION "-Y1- STA. 27+63.00"	1	L.S.
4082100000	SP	SUPPORTS, OVERHEAD SIGN STRUCTURE AT STATION "-Y1- STA. 37+00.00"	1	L.S.
4082100000	SP	SUPPORTS, OVERHEAD SIGN STRUCTURE AT STATION "-L- STA. 73+00.00"	1	L.S.
4082100000	SP	SUPPORTS, OVERHEAD SIGN STRUCTURE AT STATION "-L- STA. 95+00.00"	1	L.S.
4082100000	SP	SUPPORTS, OVERHEAD SIGN STRUCTURE AT STATION "-L- STA. 229+00.00"	1	L.S.
4096000000	904	SIGN ERECTION, TYPE D.....	1	EA.
4102000000	904	SIGN ERECTION, TYPE E.....	154	EA.
4108000000	904	SIGN ERECTION, TYPE F.....	7	EA.
4110000000	904	SIGN ERECTION, TYPE A (GROUND MOUNTED).....	9	EA.
4110000000	904	SIGN ERECTION, TYPE B (GROUND MOUNTED).....	1	EA.
4116100000	904	SIGN ERECTION, RELOCATE SIGN TYPE E.....	1	EA.
4158000000	907	DISPOSAL OF SIGN SYSTEM, WOOD.....	2	EA.
4236000000	907	DISPOSAL OF SIGN, A OR B (GROUND MOUNTED).....	2	EA.

PLAN PREPARED BY: N.C.D.O.T. SIGNING AND DELINEATION UNIT

A. ALQUDWAH, P.E. SIGNING & DELINEATION REGIONAL ENGINEER
D. M. EATON SIGNING & DELINEATION DESIGN ENGINEER

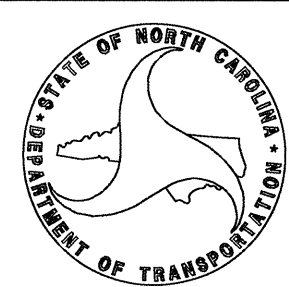

INDEX

SHEET NO.	DESCRIPTION
SIGN-1	TITLE SHEET, QUANTITIES AND NOTES
SIGN-2	SUPPORT INFORMATION
SIGN-3-3A	E AND F SHEETS
SIGN-4-4J	OVERHEAD DETAILS, OVERHEAD SIGN DESIGNS AND GROUND MOUNTED SIGN DESIGNS
SIGN-5-17	SIGN DETAIL SHEETS

AM
aw
ME

TIP NO. R-2719AA	SHEET NO. SIGN-2
APPROVED: <i>[Signature]</i>	
DATE: 2/21/12	
SEAL	

NOTES

1. DIMENSION "S" REPRESENTS AN INCREASE (+), OR A DECREASE (-) IN POLE LENGTH, RELATIVE TO THE ELEVATION OF THE EDGE OF PAVEMENT.
2. FIELD VERIFICATIONS SHALL BE REQUIRED FOR ALL SUPPORTS, SEE (*) ARTICLE 903-3. FABRICATORS SHALL BE AISC CERTIFIED IN CATEGORY 1, SEE (*) ARTICLE 1072-1. (*) = N.C.D.O.T. STANDARD SPECIFICATIONS FOR ROADS AND STRUCTURES
3. PLAN LOCATIONS FOR EXISTING UTILITIES ARE BASED ON THE BEST AVAILABLE INFORMATION AND, THEREFORE MAY NOT BE PRECISELY ACCURATE. THEREFORE, IT IS INCUMBENT UPON THE CONTRACTOR TO DETERMINE THE EXACT LOCATION OF UTILITIES BEFORE BEGINNING WORK IN A LOCATION.

SIGN NO.	SIGN TYPE	SIGN SIZE (in.)		ROADWAY STATION	NO. OF SUP.	BEAM SECTION	SUPPORT TYPE BA or S	ATTACH METHOD	MOUNTING METHOD	HORIZ. CLR.* (ft.)	LENGTH (ft)			LEFT SUPPORT (ft)			CENTER SUPPORT (ft)			RIGHT SUPPORT (ft)			FOOTING DIAMETER (ft.)	FOOTING DEPTH (ft.)	B/A SUPPORT WEIGHTS (lbs.)	SIMPLE SUPPORT WEIGHTS (lbs.)	REINF. FTGS. (c.y.)	FIELD VERIFIED SEE NOTE 2 (mm/dd/yy)	
		w	x								h	SNS HT H	MTG HT C	EMBED-MENT	S	L	TOTAL LENGTH	S	L	TOTAL LENGTH	S	L							TOTAL LENGTH
101	A	258	X	150	(-Y1-) -5+00	3	W10x22	BA	N/A	N/A	30.00	12.50	7.00	6.5	3.00	22.50	29.00	4.00	23.50	30.00	5.00	24.50	31.00	2.5	7	2338.28	0.00	3.82	
102	A	258	X	150	(-Y1-) 124+37	3	W10x22	BA	N/A	N/A	30.00	12.50	7.00	6.5	3.25	22.75	29.25	5.05	24.55	31.05	2.78	22.28	28.78	2.5	7	2318.04	0.00	3.82	
103	A	312	X	126	(-Y1-) 85+30	3	W10x26	BA	N/A	N/A	30.00	10.50	7.00	7	6.20	23.70	30.70	9.10	26.60	33.60	10.84	28.34	35.34	2.5	7.5	3022.85	0.00	4.09	
104	A	156	X	150	(-L-) 169+40	2	W8x18	BA	N/A	N/A	30.00	12.50	7.00	6.5	3.12	22.62	29.12	0.00	0.00	0.00	1.51	21.01	27.51	2	7	1181.46	0.00	1.63	
105	A	162	X	150	(-L-) 144+46	2	W8x21	BA	N/A	N/A	30.00	12.50	7.00	7	4.70	24.20	31.20	0.00	0.00	0.00	2.90	22.40	29.40	2	7.5	1458.22	0.00	1.75	
201	A	60	X	60	(-Y1-) 45+00	2	S4x7.7	BA	N/A	N/A	△	5.00	7.00	3.5	2.20	14.20	17.70	0.00	0.00	0.00	2.60	14.60	18.10	1	4	316.27	0.00	0.23	
202	A	60	X	60	(-Y1-) 80+82	2	S3x5.7	BA	N/A	N/A	△	5.00	7.00	3.5	1.00	13.00	16.50	0.00	0.00	0.00	2.00	14.00	17.50	1	4	229.33	0.00	0.23	
203A	A	72	X	60	(-L-) 67+58	2	S4x7.7	BA	N/A	2	△	7.00	7.00	4.5	0.30	14.30	18.80	0.00	0.00	0.00	0.40	14.40	18.90	1	5	330.90	0.00	0.29	
203B	B	72	X	24																									
204	A	60	X	60	(-L-) 232+24	2	S4x7.7	BA	N/A	N/A	△	5.00	7.00	3.5	2.20	14.20	17.70	0.00	0.00	0.00	2.40	14.40	17.90	1	4	314.73	0.00	0.23	

	TOTAL	TOTAL	TOTAL
	11510.09	0.00	16.09
USE:	11511	0	17

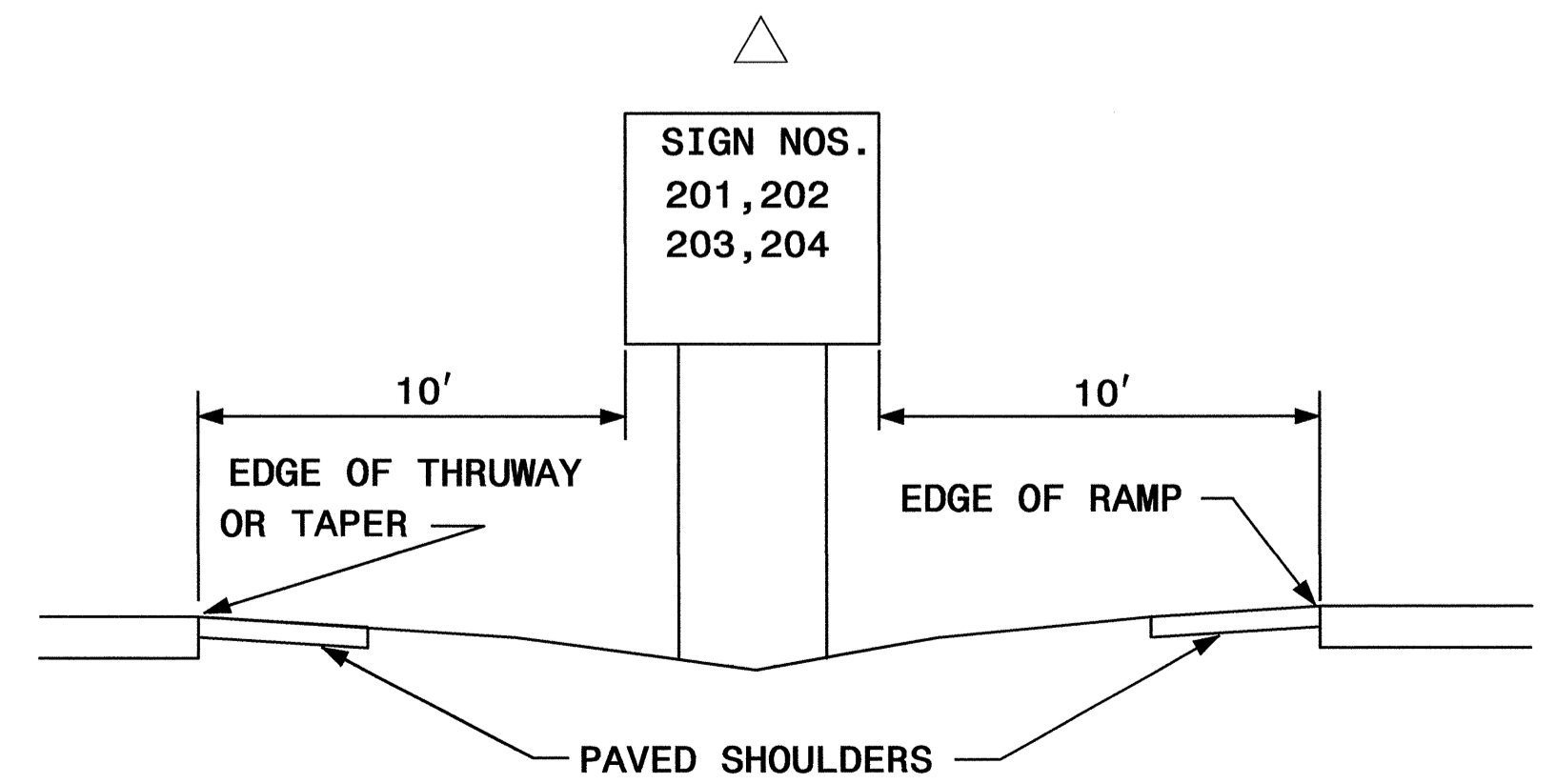
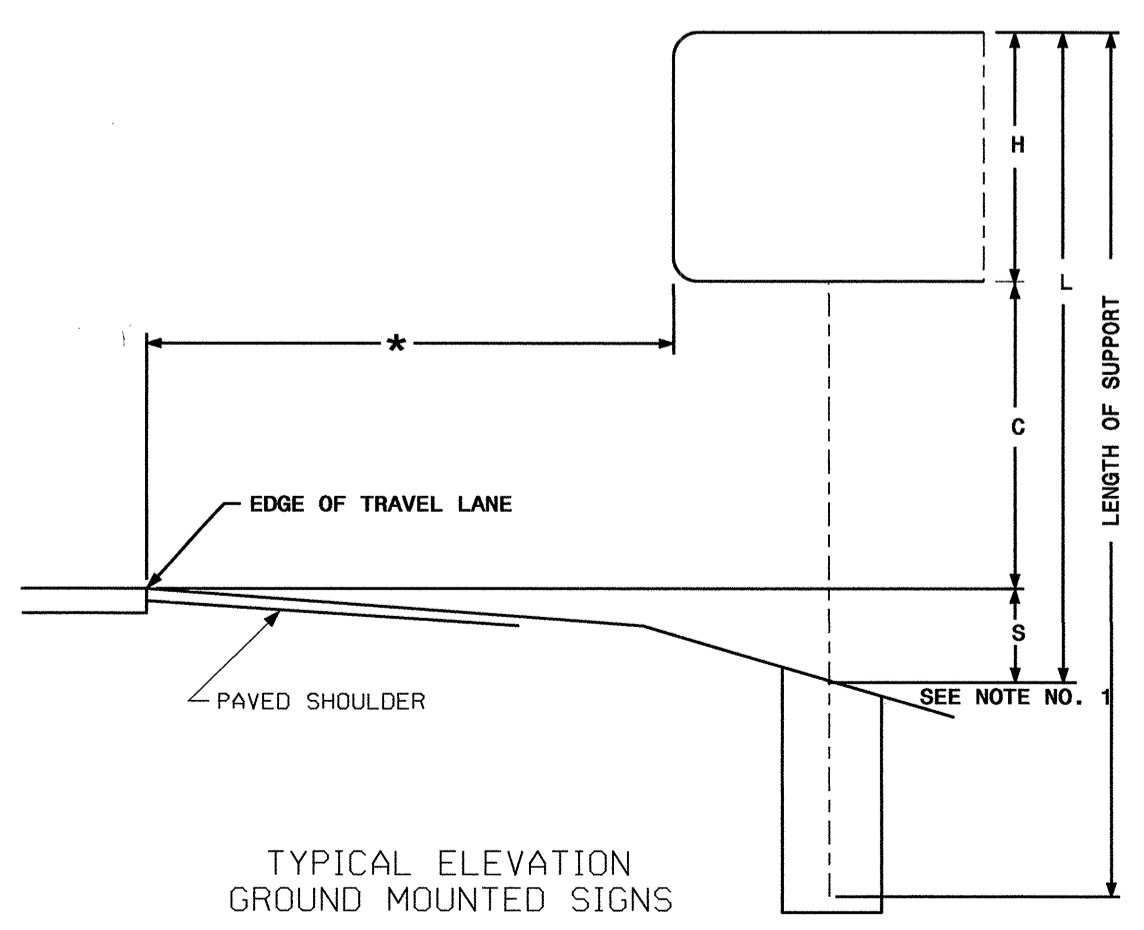

TYPE "A" AND TYPE "B" GROUND MOUNTED SIGNS

401 QUANTITY REQ'D 2

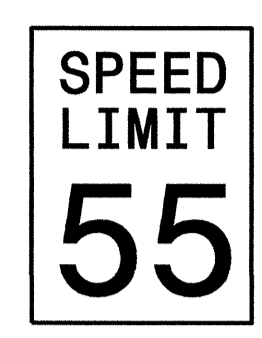

36" X 48"
R2-1

ONE WOOD POST PER SIGN

406 QUANTITY REQ'D 1



W3-5
48" X 48"

TWO WOOD POSTS PER SIGN

411 QUANTITY REQ'D 5

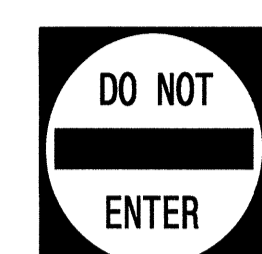

36" X 36"
R5-1

ONE WOOD POST PER SIGN

417 QUANTITY REQ'D 8

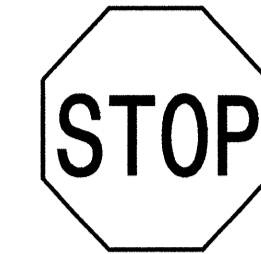

36" X 36"
R1-1

MOUNT BELOW SIGN #426
IN 8 INSTALLATIONS

422 QUANTITY REQ'D 1

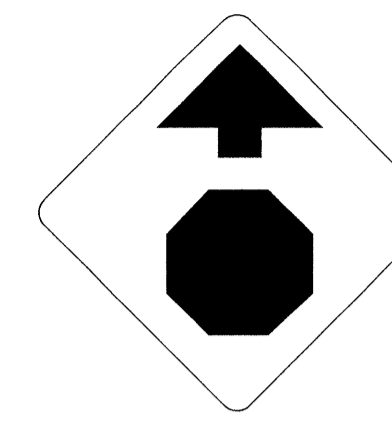

30" X 30"
W3-1

ONE WOOD POST PER SIGN

427 QUANTITY REQ'D 4



30" X 30"
W14-2

ONE WOOD POST PER SIGN

402 QUANTITY REQ'D 3



36" X 48"
R2-1

ONE WOOD POST PER SIGN

407 QUANTITY REQ'D 1

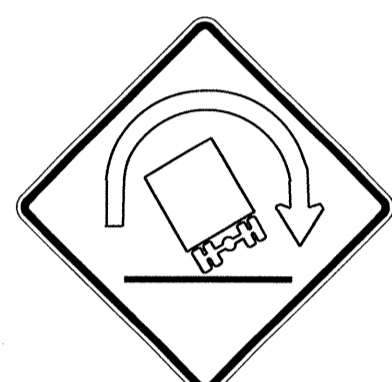

48" X 48"
W1-13

TWO WOOD POSTS PER SIGN
BLACK COPY WITH YELLOW BACKGROUND

412 QUANTITY REQ'D 7

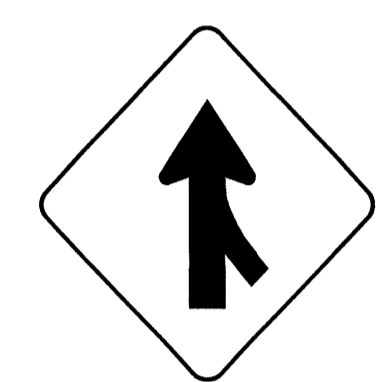

48" X 48"
W4-1

TWO WOOD POSTS PER SIGN

418 QUANTITY REQ'D 4



30" X 30"
R1-1

ONE WOOD POST PER SIGN

423 QUANTITY REQ'D 18

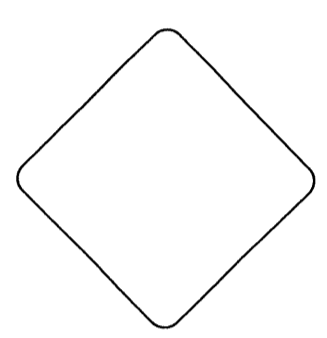

18" X 18"
OM4-3

ONE WOOD POST PER SIGN

428 QUANTITY REQ'D 3



30" X 30"
W18-11

(FROM N.C. MUTCD SUPPLEMENT)
ONE WOOD POST PER SIGN

432 QUANTITY REQ'D 1

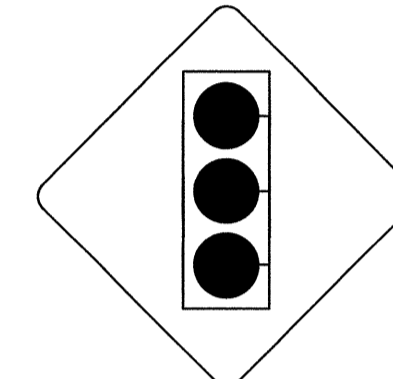

48" X 48"
W3-3

TWO WOOD POSTS PER SIGN

403 QUANTITY REQ'D 2

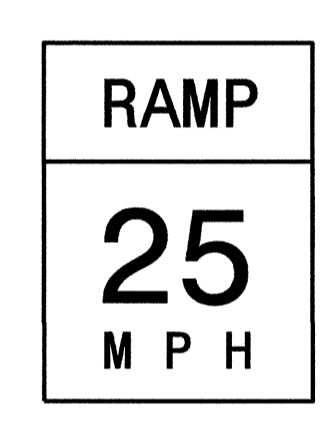

48" X 60"
W13-3

TWO WOOD POSTS PER SIGN

408 QUANTITY REQ'D 2

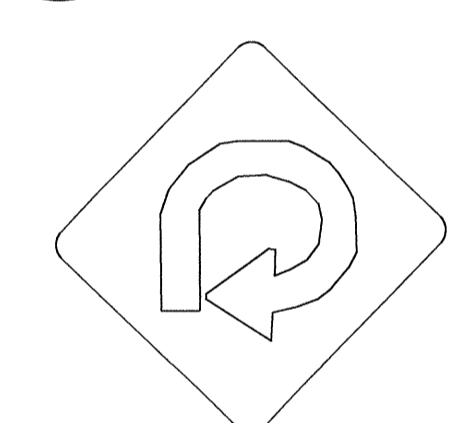

48" X 48"
W13-3

TWO WOOD POSTS PER SIGN

413 QUANTITY REQ'D 11

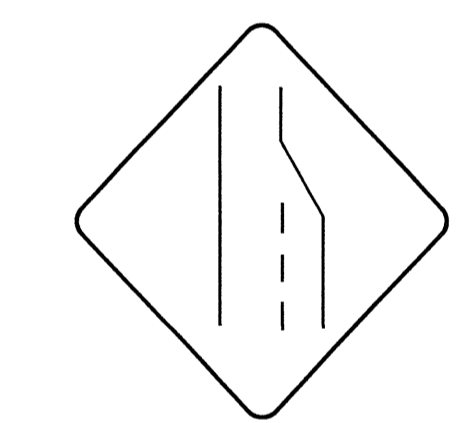

48" X 48"
W4-2(R)

TWO WOOD POSTS PER SIGN

419 QUANTITY REQ'D 3

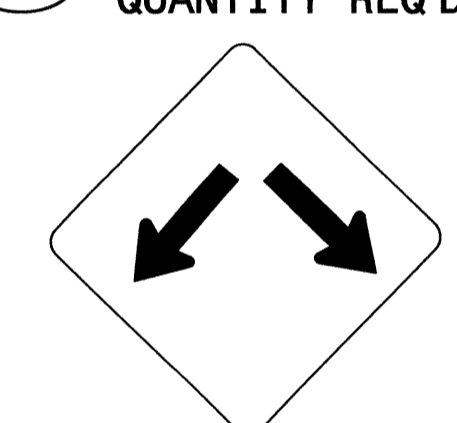

36" X 36"
W12-1

ONE WOOD POST PER SIGN

424 QUANTITY REQ'D 20

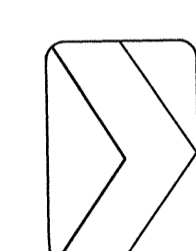

30" X 36"
W1-8R

ONE WOOD POST PER SIGN

429 QUANTITY REQ'D 1

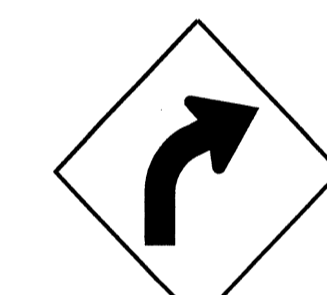

30" X 30"
W1-2R

ONE WOOD POST PER SIGN

433 QUANTITY REQ'D 1

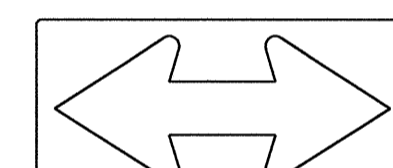

48" X 24"
W1-7

TWO WOOD POSTS PER SIGN

404 QUANTITY REQ'D 1

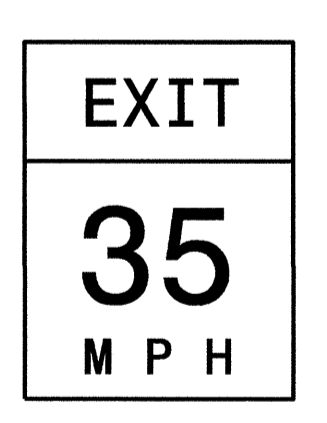

48" X 60"
W13-2

TWO WOOD POSTS PER SIGN

409 QUANTITY REQ'D 3



W13-1P
24" X 24"

1) MOUNT BELOW SIGN #407
IN 1 INSTALLATION
2) MOUNT BELOW SIGN #408
IN 2 INSTALLATION

415 QUANTITY REQ'D 10



48" X 48"
W9-1

TWO WOOD POSTS PER SIGN

420 QUANTITY REQ'D 2

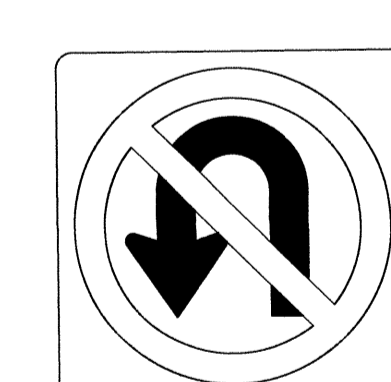

24" X 24"
R3-4

ONE WOOD POST PER SIGN

425 QUANTITY REQ'D 6

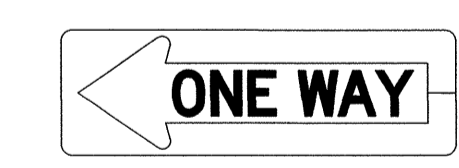

54" X 18"
R6-1

TWO WOOD POSTS PER SIGN

430 QUANTITY REQ'D 1

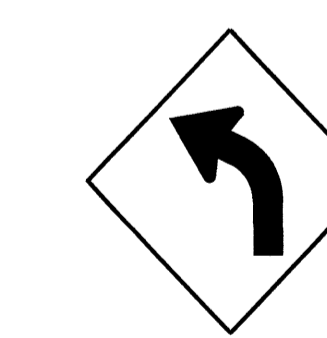

30" X 30"
W1-2L

ONE WOOD POST PER SIGN

434 QUANTITY REQ'D 6

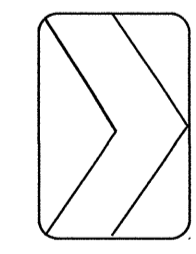

18" X 24"
W1-8R

MOUNT BACK-TO-BACK WITH SIGN #435
IN 6 INSTALLATIONS

405 QUANTITY REQ'D 1

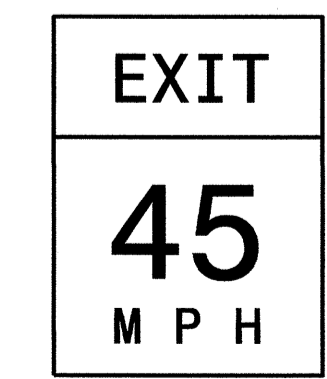

48" X 60"
W13-2

TWO WOOD POSTS PER SIGN

410 QUANTITY REQ'D 4

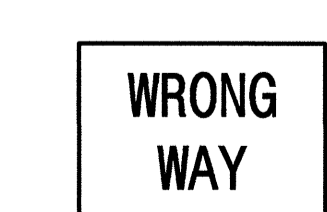

36" X 24"
R5-1a

ONE WOOD POST PER SIGN

416 QUANTITY REQ'D 2



W13-1P
18" X 18"

1) MOUNT BELOW SIGN #429
IN 1 INSTALLATION
2) MOUNT BELOW SIGN #430
IN 1 INSTALLATION

421 QUANTITY REQ'D 2

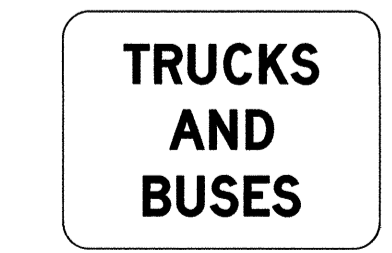

24" X 18"
(SEE SIGN DESIGN)

MOUNT BELOW SIGN #420
IN 2 INSTALLATIONS

426 QUANTITY REQ'D 9

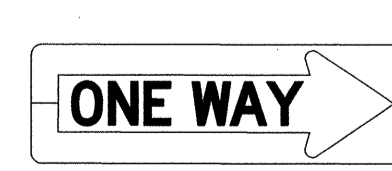

54" X 18"
R6-1

MOUNT BACK-TO-BACK WITH SIGN #425
IN 3 INSTALLATIONS
TWO WOOD POSTS PER SIGN

431 QUANTITY REQ'D 3

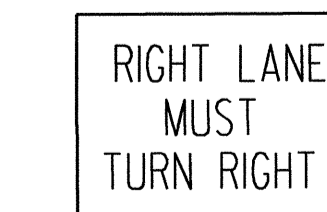

30" X 30"
R3-7R

ONE WOOD POST PER SIGN

435 QUANTITY REQ'D 6

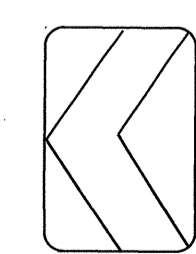

18" X 24"
W1-8L

ONE WOOD POST PER SIGN

TYPE "E" SIGNS

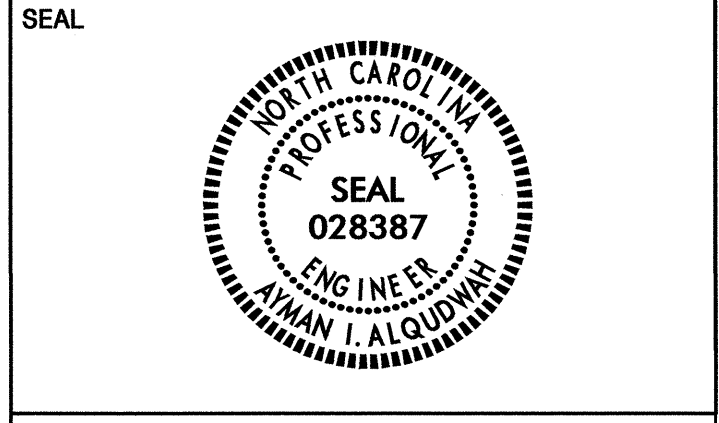

501

EXISTING SIGN

		1-24" X 12"
		1-24" X 24"
		1-21" X 15"

ONE WOOD POST

506

	1-24" X 12"
	1-24" X 24"

ONE WOOD POST

502

EXISTING SIGN

		1-24" X 12"
		1-24" X 24"
		1-21" X 15"

ONE WOOD POST

507

	1-24" X 12"
	1-24" X 24"

ONE WOOD POST

503

	1-24" X 12"
	1-24" X 24"
	1-21" X 15"

ONE WOOD POST

508

	1-30" X 15"
	1-36" X 36"

ONE WOOD POST

504

	1-24" X 12"
	1-24" X 24"
	1-21" X 15"

ONE WOOD POST

509

	1-30" X 15"
	1-36" X 36"

ONE WOOD POST

505

		2-24" X 12"
		2-30" X 24"
		2-21" X 15"

TWO WOOD POSTS

TYPE "F" SIGNS

TIP NO. R-2719AA	SHEET NO. SIGN-4
APPROVED: <i>[Signature]</i>	
DATE: 2/21/12	
SEAL	
	

NOTES:

1. IF THE CONTRACTOR BIDS ALUMIMUM SIGN STRUCTURE, EACH SHALL BE PROVIDED WITH AN APPROVED HIGHWAY TRUSS DAMPER DEVICE IN ACCORDANCE WITH AASHTO SPECIFICATIONS.
2. MOUNT SIGNS VERTICALLY CENTERED ON HORIZONTAL MEMBER OF STRUCTURE.
3. FIELD VERIFICATION SHALL BE REQUIRED FOR ALL FOOTING ELEVATIONS, PER THE LATEST NCDOT STANDARD SPECIFICATIONS FOR ROADS AND STRUCTURES.
4. THE TOP OF THE FOOTING SHALL EXTEND AT LEAST 6" AND NOT MORE THAN 24" ABOVE THE HIGHEST POINT OF THE GROUND SURFACE AT THE FOOTING.
5. SIGN HANGERS AND ATTACHMENT HARDWARE SHALL BE PROVIDED AND INSTALLED ON THE ASSEMBLY TO ACCOMMODATE ALL SIGNS SHOWN IN THE PLANS, INCLUDING THOSE DESIGNATED AS "FUTURE".

** THESE DIMENSIONS SHALL BE USED FOR WIND LOAD AND DEAD LOAD COMPUTATIONS IN DESIGN OF STRUCTURE AND FOOTINGS. DESIGN AND CONSTRUCT REQUIREMENTS FOR SIGN STRUCTURES SHALL ACCOMMODATE WIND VELOCITY OF 120 MPH.

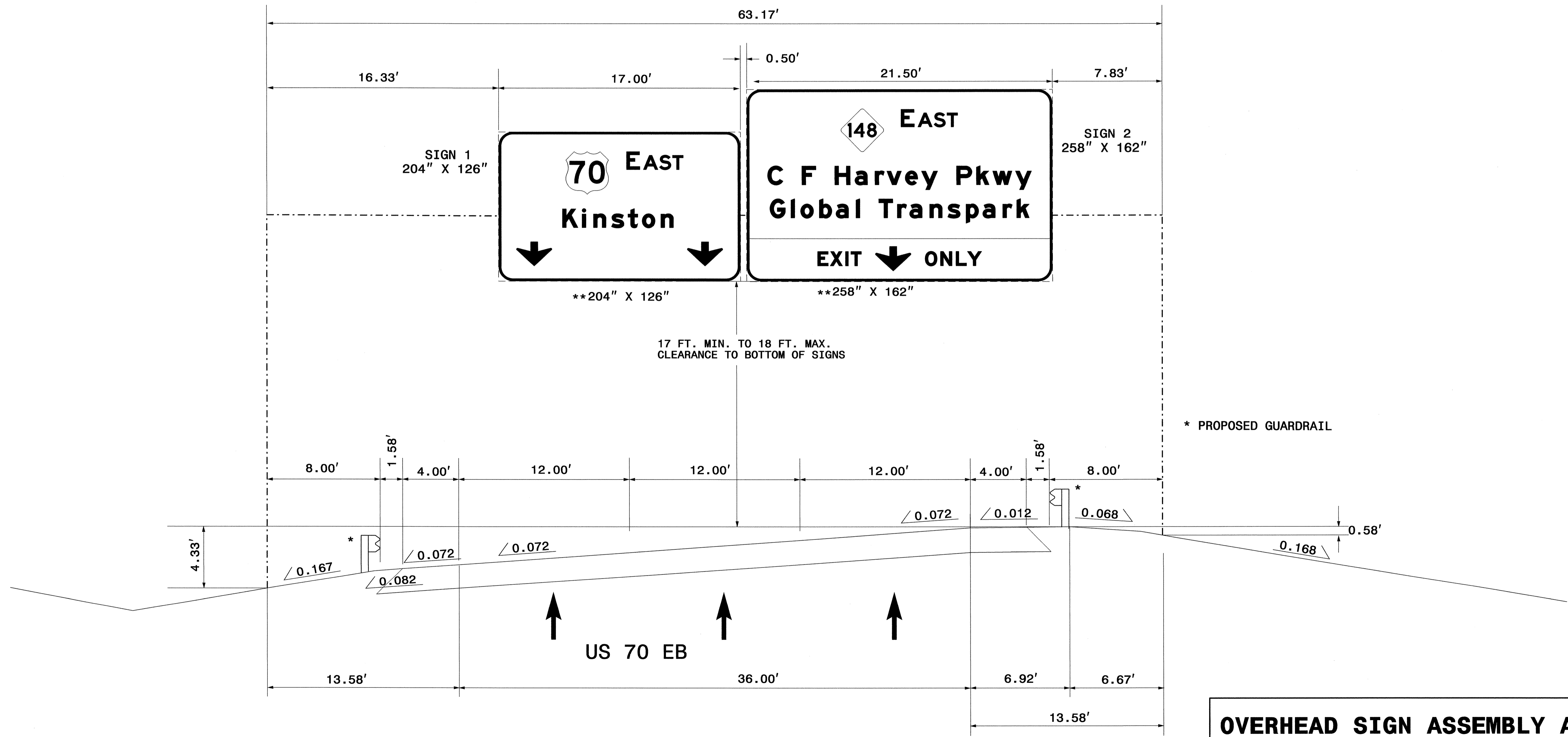

**OVERHEAD SIGN ASSEMBLY AT
-Y1- STA. 27+63.00**

TIP NO. R-2719AA	SHEET NO. SIGN-4A
APPROVED: <i>[Signature]</i>	
DATE: 2/21/12	
SEAL	

NOTES:

1. IF THE CONTRACTOR BIDS ALUMIMUM SIGN STRUCTURE, EACH SHALL BE PROVIDED WITH AN APPROVED HIGHWAY TRUSS DAMPER DEVICE IN ACCORDANCE WITH AASHTO SPECIFICATIONS.
2. MOUNT SIGNS VERTICALLY CENTERED ON HORIZONTAL MEMBER OF STRUCTURE.
3. FIELD VERIFICATION SHALL BE REQUIRED FOR ALL FOOTING ELEVATIONS, PER THE LATEST NCDOT STANDARD SPECIFICATIONS FOR ROADS AND STRUCTURES.
4. THE TOP OF THE FOOTING SHALL EXTEND AT LEAST 6" AND NOT MORE THAN 24" ABOVE THE HIGHEST POINT OF THE GROUND SURFACE AT THE FOOTING.
5. SIGN HANGERS AND ATTACHMENT HARDWARE SHALL BE PROVIDED AND INSTALLED ON THE ASSEMBLY TO ACCOMMODATE ALL SIGNS SHOWN IN THE PLANS, INCLUDING THOSE DESIGNATED AS "FUTURE".

** THESE DIMENSIONS SHALL BE USED FOR WIND LOAD AND DEAD LOAD COMPUTATIONS IN DESIGN OF STRUCTURE AND FOOTINGS. DESIGN AND CONSTRUCT REQUIREMENTS FOR SIGN STRUCTURES SHALL ACCOMMODATE WIND VELOCITY OF 120 MPH.

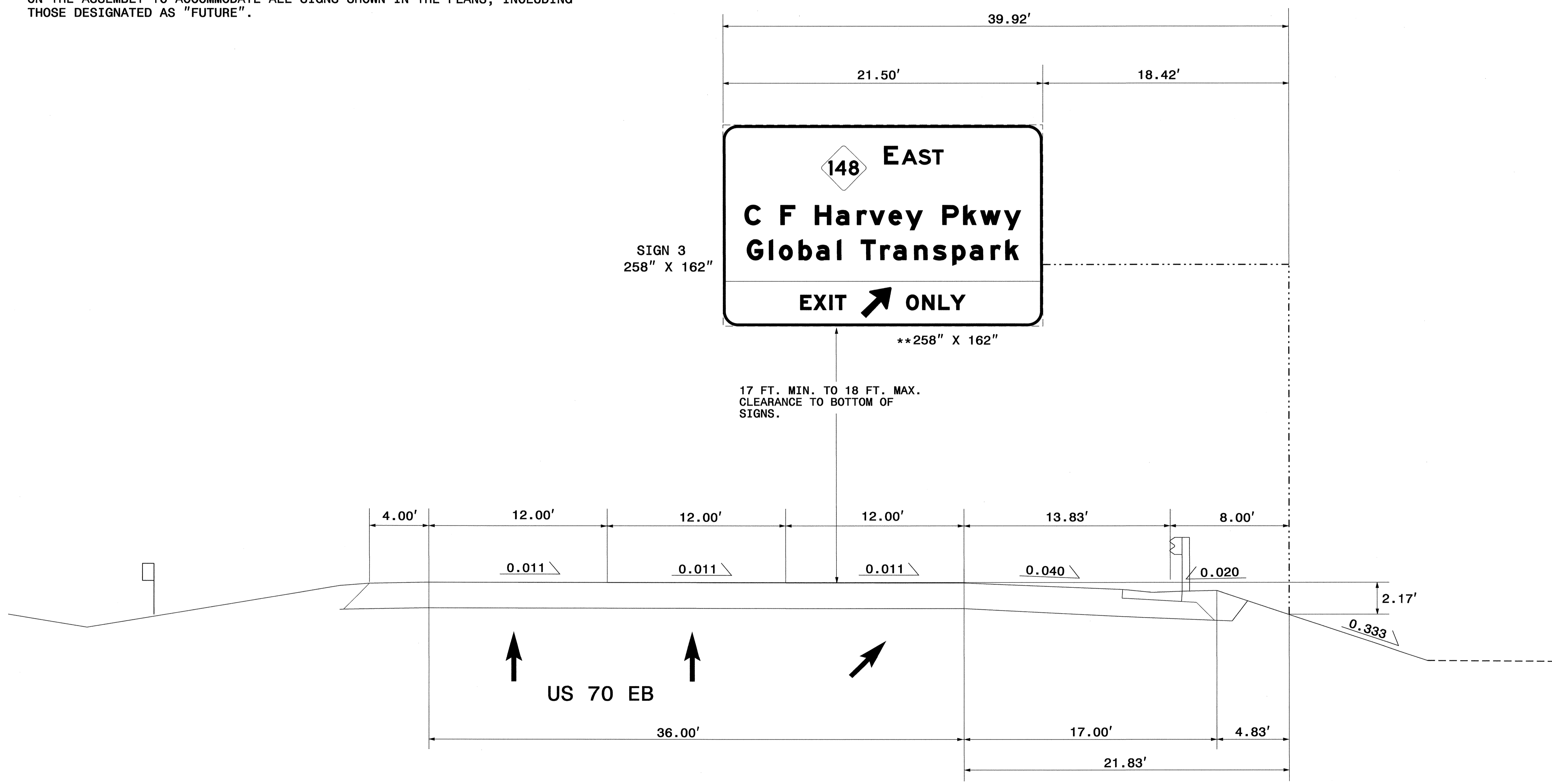

**OVERHEAD SIGN ASSEMBLY AT
-Y1- STA. 37+00.00**

TIP NO. R-2719AA	SHEET NO. SIGN-4B
APPROVED: <i>[Signature]</i>	
DATE: 2/2/12	
SEAL	

NOTES:

1. IF THE CONTRACTOR BIDS ALUMIMUM SIGN STRUCTURE, EACH SHALL BE PROVIDED WITH AN APPROVED HIGHWAY TRUSS DAMPER DEVICE IN ACCORDANCE WITH AASHTO SPECIFICATIONS.
2. MOUNT SIGNS VERTICALLY CENTERED ON HORIZONTAL MEMBER OF STRUCTURE.
3. FIELD VERIFICATION SHALL BE REQUIRED FOR ALL FOOTING ELEVATIONS, PER THE LATEST NCDOT STANDARD SPECIFICATIONS FOR ROADS AND STRUCTURES.
4. THE TOP OF THE FOOTING SHALL EXTEND AT LEAST 6" AND NOT MORE THAN 24" ABOVE THE HIGHEST POINT OF THE GROUND SURFACE AT THE FOOTING.
5. SIGN HANGERS AND ATTACHMENT HARDWARE SHALL BE PROVIDED AND INSTALLED ON THE ASSEMBLY TO ACCOMMODATE ALL SIGNS SHOWN IN THE PLANS, INCLUDING THOSE DESIGNATED AS "FUTURE".

** THESE DIMENSIONS SHALL BE USED FOR WIND LOAD AND DEAD LOAD COMPUTATIONS IN DESIGN OF STRUCTURE AND FOOTINGS. DESIGN AND CONSTRUCT REQUIREMENTS FOR SIGN STRUCTURES SHALL ACCOMMODATE WIND VELOCITY OF 120 MPH.

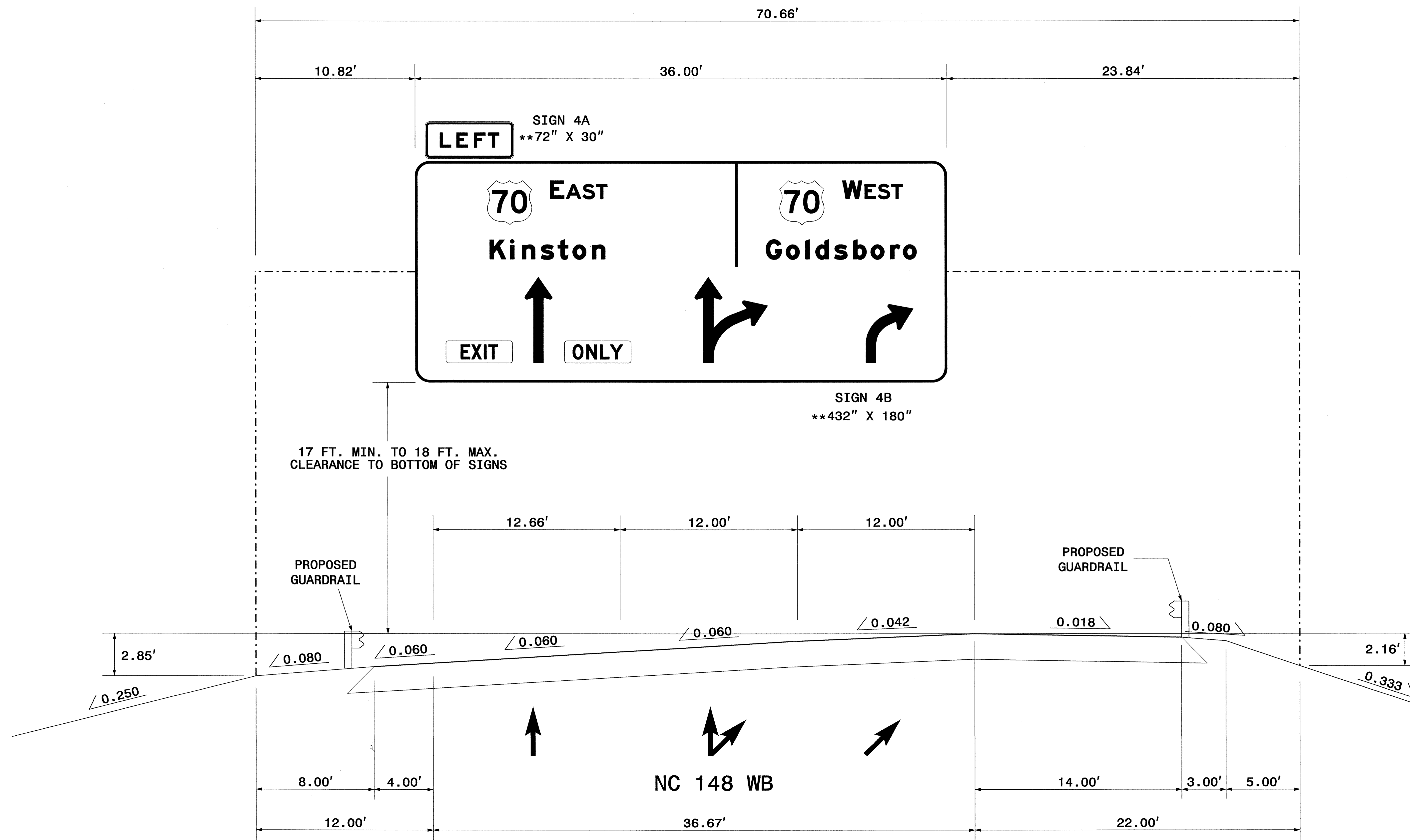

**OVERHEAD SIGN ASSEMBLY AT
-L- STA. 73+00.00**

TIP NO. R-2719AA	SHEET NO. SIGN 4C
APPROVED: <i>[Signature]</i>	
DATE: 2/21/12	
SEAL	



NOTES:

1. IF THE CONTRACTOR BIDS ALUMIMUM SIGN STRUCTURE, EACH SHALL BE PROVIDED WITH AN APPROVED HIGHWAY TRUSS DAMPER DEVICE IN ACCORDANCE WITH AASHTO SPECIFICATIONS.
2. MOUNT SIGNS VERTICALLY CENTERED ON HORIZONTAL MEMBER OF STRUCTURE.
3. FIELD VERIFICATION SHALL BE REQUIRED FOR ALL FOOTING ELEVATIONS, PER THE LATEST NCDOT STANDARD SPECIFICATIONS FOR ROADS AND STRUCTURES.
4. THE TOP OF THE FOOTING SHALL EXTEND AT LEAST 6" AND NOT MORE THAN 24" ABOVE THE HIGHEST POINT OF THE GROUND SURFACE AT THE FOOTING.
5. SIGN HANGERS AND ATTACHMENT HARDWARE SHALL BE PROVIDED AND INSTALLED ON THE ASSEMBLY TO ACCOMMODATE ALL SIGNS SHOWN IN THE PLANS, INCLUDING THOSE DESIGNATED AS "FUTURE".

** THESE DIMENSIONS SHALL BE USED FOR WIND LOAD AND DEAD LOAD COMPUTATIONS IN DESIGN OF STRUCTURE AND FOOTINGS. DESIGN AND CONSTRUCT REQUIREMENTS FOR SIGN STRUCTURES SHALL ACCOMMODATE WIND VELOCITY OF 120 MPH.

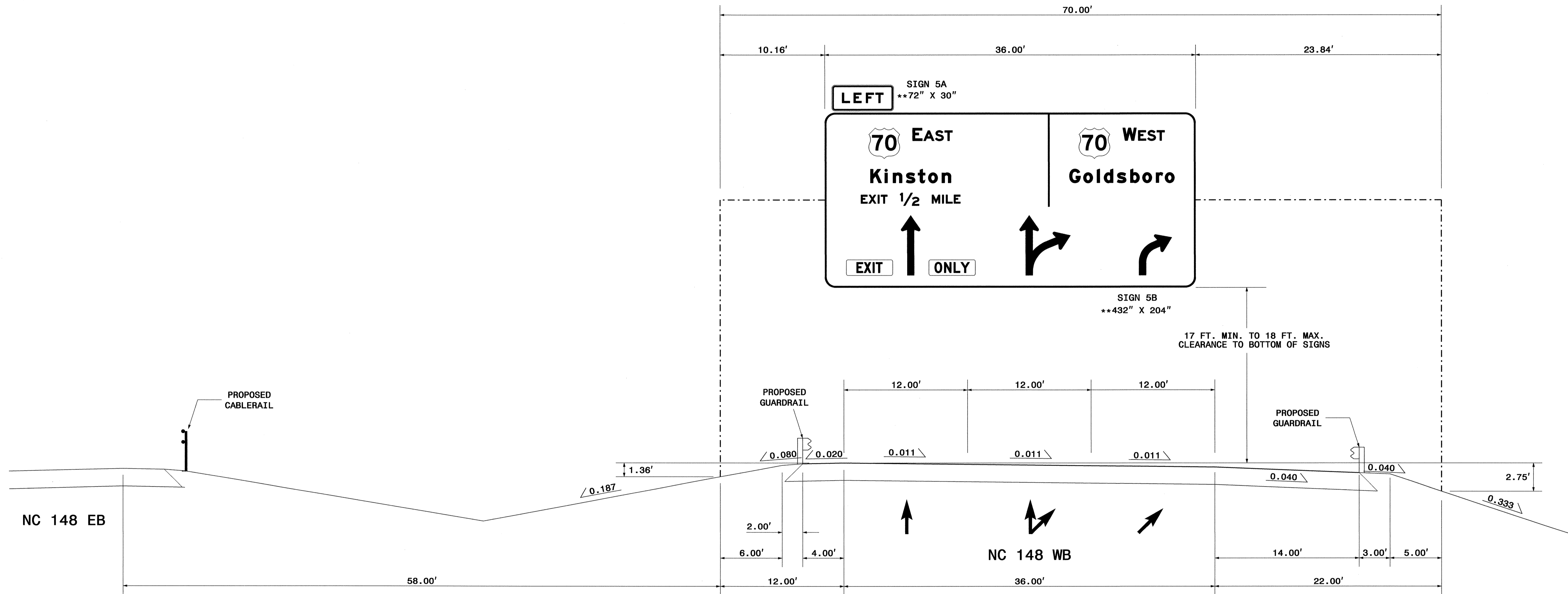

**OVERHEAD SIGN ASSEMBLY AT
-L- STA. 95+00.00**

TIP NO. R-2719AA	SHEET NO. SIGN-4D
APPROVED: <i>[Signature]</i>	
DATE: 2/21/12	
SEAL	

** THESE DIMENSIONS SHALL BE USED FOR WIND LOAD AND DEAD LOAD COMPUTATIONS IN DESIGN OF STRUCTURE AND FOOTINGS. DESIGN AND CONSTRUCT REQUIREMENTS FOR SIGN STRUCTURES SHALL ACCOMMODATE WIND VELOCITY OF 120 MPH.

NOTES:

1. IF THE CONTRACTOR BIDS ALUMIMUM SIGN STRUCTURE, EACH SHALL BE PROVIDED WITH AN APPROVED HIGHWAY TRUSS DAMPER DEVICE IN ACCORDANCE WITH AASHTO SPECIFICATIONS.
2. MOUNT SIGNS VERTICALLY CENTERED ON HORIZONTAL MEMBER OF STRUCTURE.
3. FIELD VERIFICATION SHALL BE REQUIRED FOR ALL FOOTING ELEVATIONS, PER THE LATEST NCDOT STANDARD SPECIFICATIONS FOR ROADS AND STRUCTURES.
4. THE TOP OF THE FOOTING SHALL EXTEND AT LEAST 6" AND NOT MORE THAN 24" ABOVE THE HIGHEST POINT OF THE GROUND SURFACE AT THE FOOTING.
5. SIGN HANGERS AND ATTACHMENT HARDWARE SHALL BE PROVIDED AND INSTALLED ON THE ASSEMBLY TO ACCOMMODATE ALL SIGNS SHOWN IN THE PLANS, INCLUDING THOSE DESIGNATED AS "FUTURE".

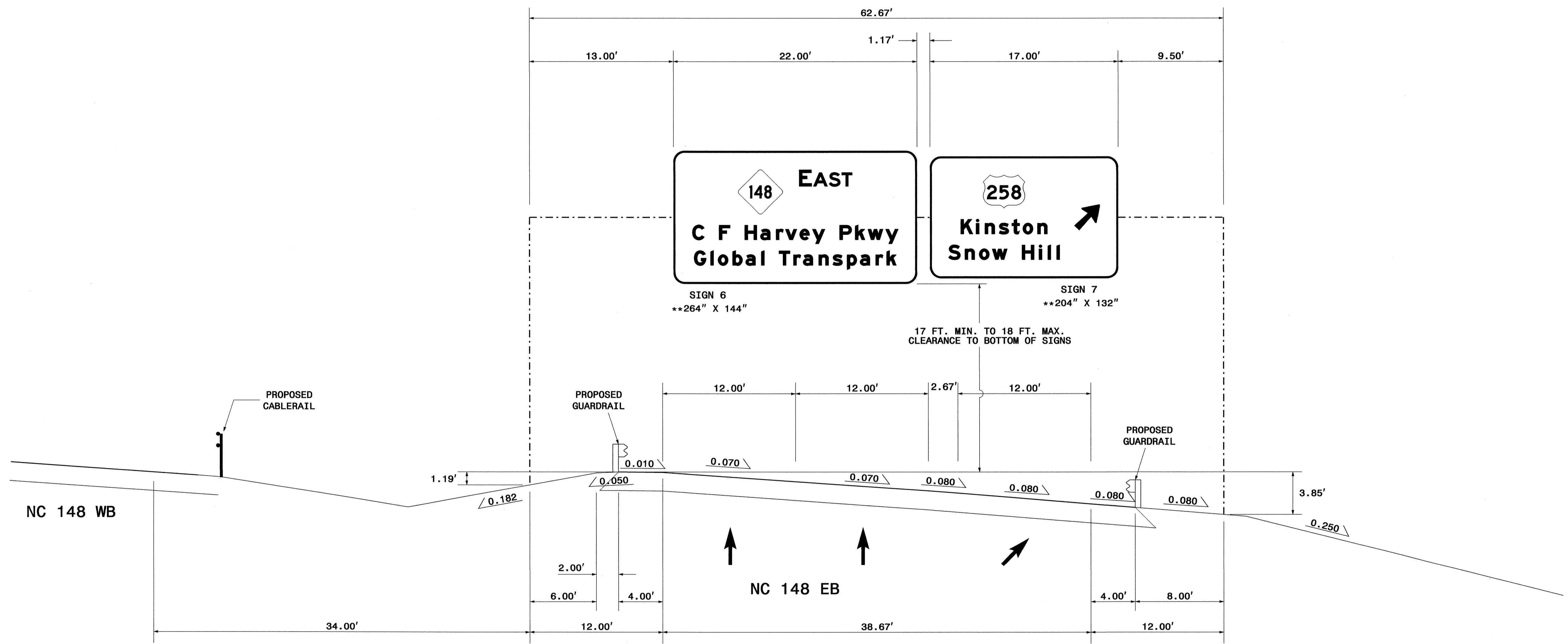

**OVERHEAD SIGN ASSEMBLY AT
-L- STA. 229+00.00**

TIP NO. R-2719AA	SHEET NO. SIGN-4E
APPROVED: <i>John R. [Signature]</i>	
DATE: 2/21/12	
SEAL	



<p>SIGN NUMBER: 1 TYPE: A QUANTITY: 1</p> <p>SIGN WIDTH: 17'-0" HEIGHT: 10'-6" TOTAL AREA: 178.5 Sq.Ft.</p> <p>BORDER TYPE: FLUSH RECESS: 0" WIDTH: 2" RADII: 12"</p> <p>NO. Z BARS: 3 LENGTH: 196.0</p>	<p>BACKG COLOR: White COPY COLOR: Green</p> <table border="1"> <thead> <tr> <th>SYMBOL</th> <th>X</th> <th>Y</th> <th>WID</th> <th>HT</th> </tr> </thead> <tbody> <tr> <td>M1_4</td> <td>56.7</td> <td>73.4</td> <td>36</td> <td>36</td> </tr> <tr> <td>ARNDOWN</td> <td>14.9</td> <td>12.6</td> <td>29.9</td> <td>20.5</td> </tr> <tr> <td>ARNDOWN</td> <td>159.2</td> <td>12.6</td> <td>29.9</td> <td>20.5</td> </tr> </tbody> </table> <p>MAT'L: 0.125" (3.2 mm) ALUMINUM</p>	SYMBOL	X	Y	WID	HT	M1_4	56.7	73.4	36	36	ARNDOWN	14.9	12.6	29.9	20.5	ARNDOWN	159.2	12.6	29.9	20.5	<p>DESIGN BY: D.P. CHECKED BY: AIA PROJECT ID: R-2719AA DIV: 2 DATE: July 18, 2011</p>
SYMBOL	X	Y	WID	HT																		
M1_4	56.7	73.4	36	36																		
ARNDOWN	14.9	12.6	29.9	20.5																		
ARNDOWN	159.2	12.6	29.9	20.5																		

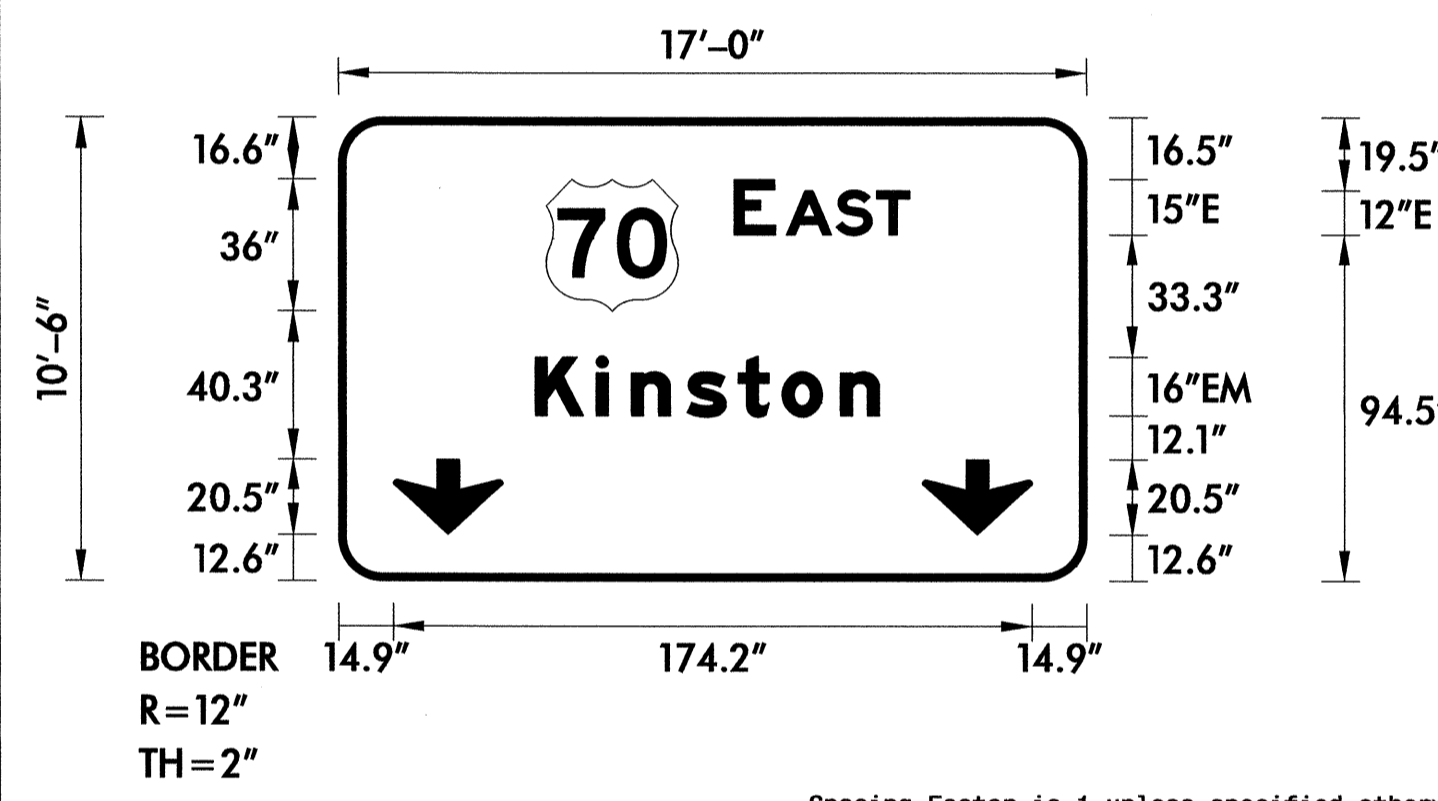

USE NOTES: 1,2,3,4

- Legend and border shall be direct applied Grade A, sheeting.
- Background shall be Grade C reflective sheeting.
- Shields shall be on 0.032" (0.8mm) aluminum and demountable.
- Shields shall be Grade A sheeting.
- Bottom panel shall be yellow Grade C sheeting. Legend shall be direct applied black non-reflective sheeting. Yellow panel is: 108" X 30"

LETTER POSITIONS

Letter locations are panel edge to lower left corner										Series/Size	
E	A	S	T							Text	Length
107.9	122.2	135.8	146.8							E 2000	47.9
53.7	70.3	79.9	95.1	109.1	121.1	136.9				EM 2000	93.8

FILENAME: Signs_OverheadsR2719AA NORTH CAROLINA D.O.T. SIGN DETAIL

<p>SIGN NUMBER: 2 TYPE: A QUANTITY: 1</p> <p>SIGN WIDTH: 21'-6" HEIGHT: 13'-6" TOTAL AREA: 290.3 Sq.Ft.</p> <p>BORDER TYPE: FLUSH RECESS: 0" WIDTH: 2" RADII: 12"</p> <p>NO. Z BARS: 4 LENGTH: 250.0</p>	<p>BACKG COLOR: Green COPY COLOR: White</p> <table border="1"> <thead> <tr> <th>SYMBOL</th> <th>X</th> <th>Y</th> <th>WID</th> <th>HT</th> </tr> </thead> <tbody> <tr> <td>M1-5-3-36-12D</td> <td>79.6</td> <td>109.7</td> <td>36</td> <td>36</td> </tr> <tr> <td>ARNDOWN</td> <td>108.5</td> <td>8.7</td> <td>30</td> <td>20.6</td> </tr> </tbody> </table> <p>MAT'L: 0.125" (3.2 mm) ALUMINUM</p>	SYMBOL	X	Y	WID	HT	M1-5-3-36-12D	79.6	109.7	36	36	ARNDOWN	108.5	8.7	30	20.6	<p>DESIGN BY: D.P. CHECKED BY: AIA PROJECT ID: R-2719AA DIV: 2 DATE: July 18, 2011</p>
SYMBOL	X	Y	WID	HT													
M1-5-3-36-12D	79.6	109.7	36	36													
ARNDOWN	108.5	8.7	30	20.6													

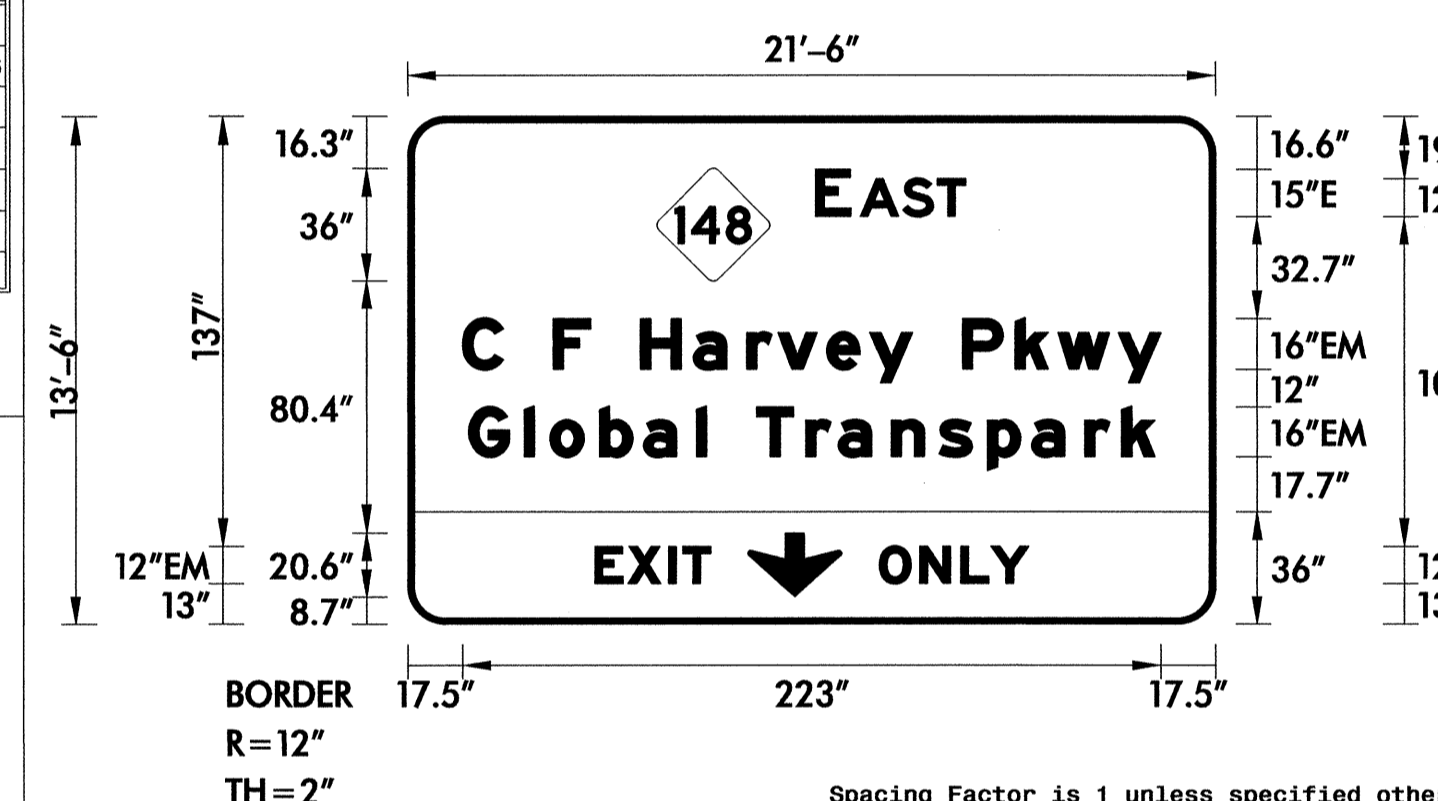

USE NOTES: 1,2,3,4,5

- Legend and border shall be direct applied Grade A, sheeting.
- Background shall be Grade C reflective sheeting.
- Shields shall be on 0.032" (0.8mm) aluminum and demountable.
- Shields shall be Grade A sheeting.
- Bottom panel shall be yellow Grade C sheeting. Legend shall be direct applied black non-reflective sheeting. Yellow panel is: 258" X 36"

LETTER POSITIONS

Letter locations are panel edge to lower left corner										Series/Size							
E	A	S	T							Text	Length						
130.3	144.5	158.1	169.1							E 2000	47.9						
17.5	30.4	46.4	58.3	74.3	91.2	108.2	118.3	133.8	147.6	161.2	177.2	194	207.7	226.9	EM 2000	223	
19.4	37.1	45.3	61.1	75.2	92.2	95.4	111.4	127	137.4	154.4	169.6	185.1	199.2	216.2	228	EM 2000	219.2
59.7	70.3	83.2	87.8							EM 2000	37						
150.5	163.5	176.6	186.2							EM 2000	47.8						

FILENAME: Signs_OverheadsR2719AA NORTH CAROLINA D.O.T. SIGN DETAIL

OVERHEAD SIGN DESIGNS

TIP NO. R-2719AA	SHEET NO. SIGN-4F
APPROVED: <i>[Signature]</i>	
DATE: 2/21/12	
SEAL	
	

SIGN NUMR: 4B
 TYPE: A Overhead
 QUANTITY: 1
 SIGN WIDTH: 36'-0"
 HEIGHT: 15'-6"
 TOTAL AREA: 558.0 Sq.Ft.
 EXIT PANEL AREA: 13.5 Sq.Ft.
 MAT'L: 0.125" ALUMINUM

SYMBOL	X	Y	WID	HT
M1_4	51.3	132.2	36	36
M1_4	296.1	132.2	36	36
AR_THRU	88.9	20.3	22.2	69.9
AR_THRU_RIGHT	226.9	20.3	59.3	69.9
AR_RIGHT_ONLY	365.9	20.3	38.4	47.6

BORDER TYPE: FLUSH
 RECESS: 0"
 WIDTH: 2"
 RADII: 12"
 NO. Z BARS: 6
 LENGTH: 424.0"

USE NOTES: 1,3,5,7
 1. Legend and border shall be direct applied Grade A reflective sheeting.
 2. Legend and border shall be direct applied Grade C reflective sheeting.
 3. Shields shall be Grade A reflective sheeting on 0.032" aluminum and demountable.
 4. Background shall be Grade B reflective sheeting.
 5. Background shall be Grade C reflective sheeting.
 6. Center arrow(s) vertically on sign.
 7. Bottom panels shall be Yellow Grade A sheeting. Legend shall be direct applied black non-reflective sheeting. Yellow panels are: 54" X 18".

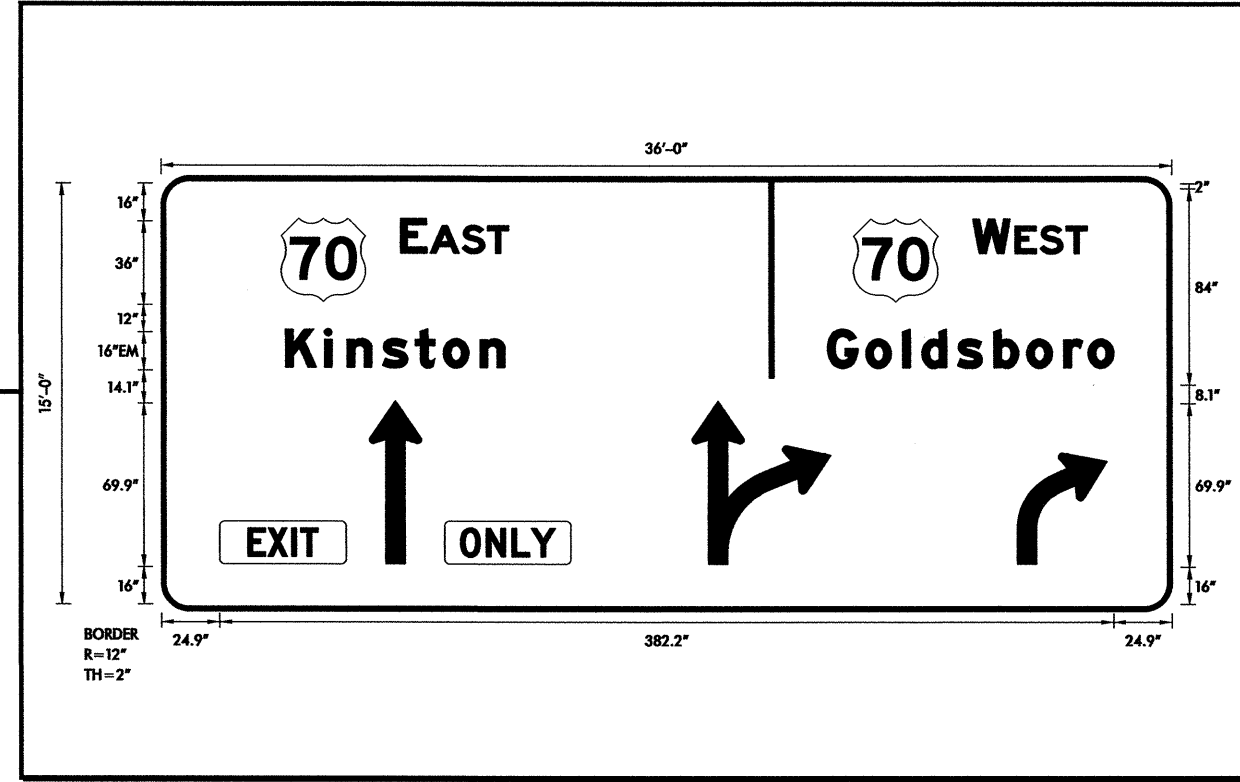

Letter spacings are to start of next letter

Series/Size	Text Length
E 2000	46.4
E 2000	48.8
EM 2000	93.8
EM 2000	122.2
D 2000	30
D 2000	40.7

Spacing Factor is 1 unless specified otherwise
FILENAME: GSENG

SIGN NUMBER: 3
 TYPE: A
 QUANTITY: 1
 SIGN WIDTH: 21'-6"
 HEIGHT: 13'-6"
 TOTAL AREA: 290.3 Sq.Ft.

SYMBOL	X	Y	WID	HT
M1-5-3-36-12D	79.6	109.4	36	36
ARMED	111.4	6.8	20	31.5

BORDER TYPE: FLUSH
 RECESS: 0"
 WIDTH: 2"
 RADII: 12"
 NO. Z BARS: 4
 LENGTH: 250.0

USE NOTES: 1,2,3,4,5
 1. Legend and border shall be direct applied Grade A, sheeting.
 2. Background shall be Grade C reflective sheeting.
 3. Shields shall be on 0.032" (0.8mm) aluminum and demountable.
 4. Shields shall be Grade A sheeting.
 5. Bottom panel shall be yellow Grade C sheeting. Legend shall be direct applied black non-reflective sheeting. Yellow panel is: 258" X 36"

DESIGN BY: D.P.
 CHECKED BY: AIA
 PROJECT ID: R-2719AA
 DIV: 2
 DATE: July 18, 2011

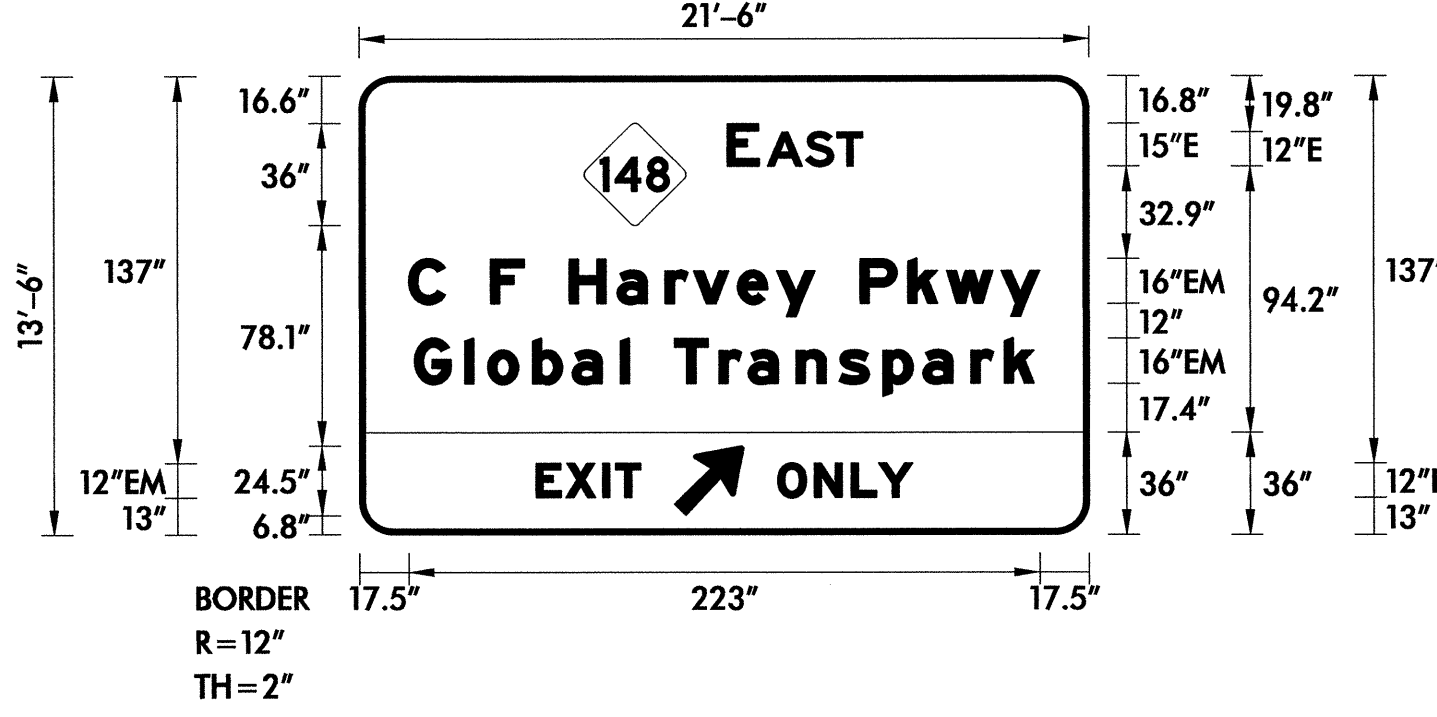

Spacing Factor is 1 unless specified otherwise

LETTER POSITIONS

Letter locations are panel edge to lower left corner

Series/Size	Text Length
E 2000	47.9
EM 2000	223
EM 2000	219.2
EM 2000	37
EM 2000	47.8

FILENAME: Signs_OverheadsR2719AA
NORTH CAROLINA D.O.T. SIGN DETAIL

SIGN NUMR: 5B
 TYPE: A Overhead
 QUANTITY: 1
 SIGN WIDTH: 36'-0"
 HEIGHT: 17'-0"
 TOTAL AREA: 612.0 Sq.Ft.
 EXIT PANEL AREA: 13.5 Sq.Ft.
 MAT'L: 0.125" ALUMINUM

SYMBOL	X	Y	WID	HT
M1_4	51.3	150.2	36	36
M1_4	296.1	150.2	36	36
AR_THRU	88.9	14.3	22.2	69.9
AR_THRU_RIGHT	226.9	14.3	59.3	69.9
AR_RIGHT_ONLY	365.9	14.3	38.4	47.6

BORDER TYPE: FLUSH
 RECESS: 0"
 WIDTH: 2"
 RADII: 12"
 NO. Z BARS: 6
 LENGTH: 424.0"

USE NOTES: 1,3,5,7
 1. Legend and border shall be direct applied Grade A reflective sheeting.
 2. Legend and border shall be direct applied Grade C reflective sheeting.
 3. Shields shall be Grade A reflective sheeting on 0.032" aluminum and demountable.
 4. Background shall be Grade B reflective sheeting.
 5. Background shall be Grade C reflective sheeting.
 6. Center arrow(s) vertically on sign.
 7. Bottom panels shall be Yellow Grade A sheeting. Legend shall be direct applied black non-reflective sheeting. Yellow panels are: 54" X 18".

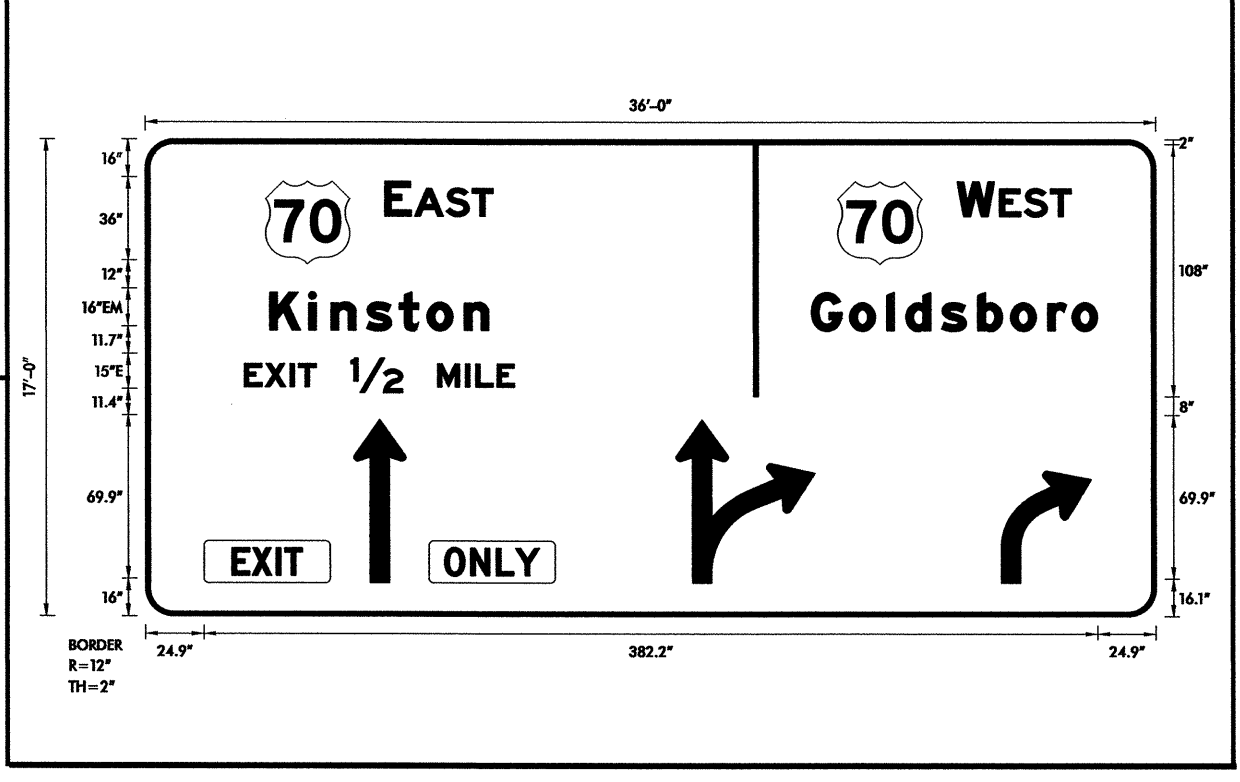

Letter spacings are to start of next letter

Series/Size	Text Length
E 2000	46.4
E 2000	48.8
EM 2000	93.8
EM 2000	122.2
E 2000	115.7
D 2000	30
D 2000	40.7

Spacing Factor is 1 unless specified otherwise
FILENAME: GSENG

OVERHEAD SIGN DESIGNS

TIP NO. R-2719AA	SHEET NO. SIGN-4G
APPROVED: <i>[Signature]</i>	
DATE: 2/2/12	
SEAL	
	

SIGN NUMR: 6 BACKG. COLOR: Green DESIGN BY: DME CHK BY: STD #: S\$TN N. C. DEPARTMENT OF TRANSPORTATION
 TYPE: A Overhead COPY COLOR: White PROJECT ID: R-2719AA DIV: 2 DATE: Feb 07, 2012 DIVISION OF HIGHWAYS
 QUANTITY: 1 TRAFFIC ENGINEERING BRANCH
 SIGNING DEPARTMENT

SIGN WIDTH: 22'-0"
 HEIGHT: 12'-0"
 TOTAL AREA: 264.0 Sq.Ft.

SYMBOL	X	Y	WID	HT
W1-5-3-24-7C	70.3	75.8	48	48

MAT'L: 0.125" ALUMINUM

BORDER TYPE: FLUSH
 RECESS: 0"
 WIDTH: 2"
 RADII: 12"
 NO. Z BARS: 3
 LENGTH: 256.0"

USE NOTES: 1,3,5
 1. Legend and border shall be direct applied Grade A reflective sheeting.
 2. Legend and border shall be direct applied Grade C reflective sheeting.
 3. Shields shall be Grade A reflective sheeting on 0.032" aluminum and demountable.
 4. Background shall be Grade B reflective sheeting.
 5. Background shall be Grade C reflective sheeting.
 6. Center arrow(s) vertically on sign.

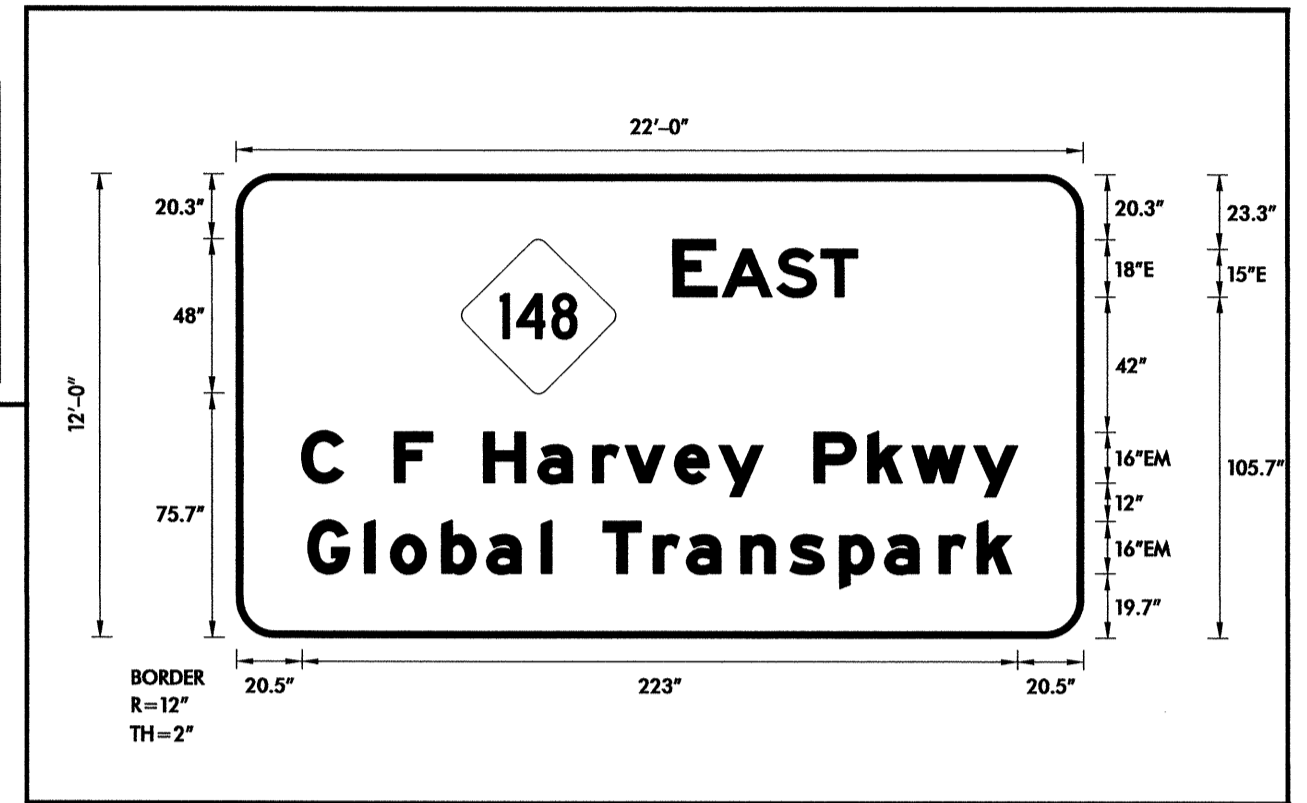

Letter spacings are to start of next letter

Series/Size	Text Length
E 2000	57.4
EM 2000	223
EM 2000	219.2

Spacing Factor is 1 unless specified otherwise
 FILENAME: GSENG

SIGN NUMR: 4A,5A BACKG. COLOR: Yellow DESIGN BY: DME CHK BY: STD #: S\$TN N. C. DEPARTMENT OF TRANSPORTATION
 TYPE: B Overhead COPY COLOR: Black PROJECT ID: R-2719AA DIV: 2 DATE: Feb 06, 2012 DIVISION OF HIGHWAYS
 QUANTITY: 2 TRAFFIC ENGINEERING BRANCH
 SIGNING DEPARTMENT

SIGN WIDTH: 6'-0"
 HEIGHT: 2'-6"
 TOTAL AREA: 15.0 Sq.Ft.
 #.# # SM/Sq.Ft.

SYMBOL	X	Y	WID	HT
--------	---	---	-----	----

MAT'L: 0.125" ALUMINUM

BORDER TYPE: RECESSED
 RECESS: 0.75"
 WIDTH: 0.75"
 RADII: 3.75"
 NO. Z BARS: 2
 LENGTH: 64.0"

USE NOTES: 2,5
 1. Legend and border shall be direct applied Grade A reflective sheeting.
 2. Legend and border shall be direct applied Grade C reflective sheeting.
 3. Shields shall be Grade A reflective sheeting on 0.032" aluminum and demountable.
 4. Background shall be Grade B reflective sheeting.
 5. Background shall be Grade C reflective sheeting.
 6. Center arrow(s) vertically on sign.

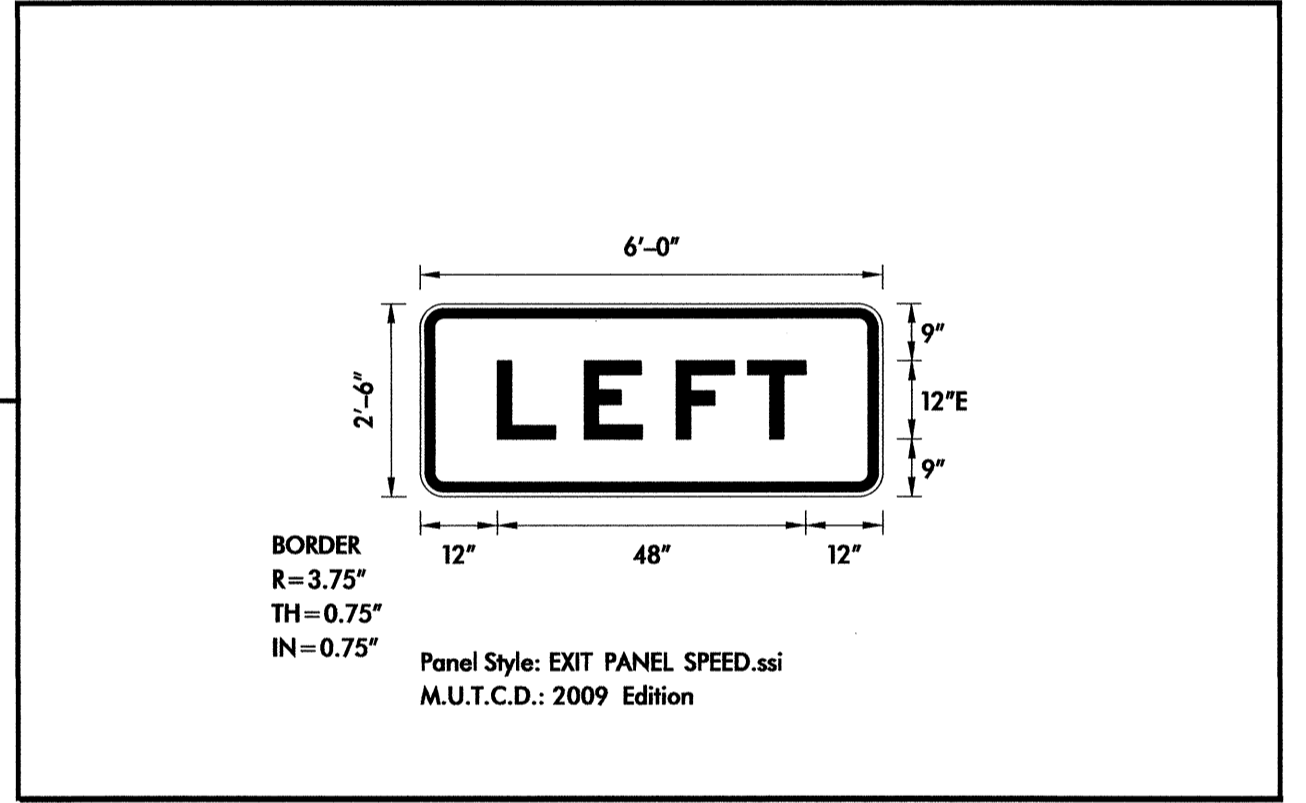

Letter spacings are to start of next letter

Series/Size	Text Length
E 2000	48

Spacing Factor is 1 unless specified otherwise
 FILENAME: GSENG

SIGN NUMR: 7 BACKG. COLOR: Green DESIGN BY: DME CHK BY: STD #: S\$TN N. C. DEPARTMENT OF TRANSPORTATION
 TYPE: A Overhead COPY COLOR: White PROJECT ID: R-2719AA DIV: 2 DATE: Feb 07, 2012 DIVISION OF HIGHWAYS
 QUANTITY: 1 TRAFFIC ENGINEERING BRANCH
 SIGNING DEPARTMENT

SIGN WIDTH: 17'-0"
 HEIGHT: 11'-0"
 TOTAL AREA: 187.0 Sq.Ft.

SYMBOL	X	Y	WID	HT
W1_4	57.7	76	45	36
AR_Type A	156.5	62.2	22.3	35

MAT'L: 0.125" ALUMINUM

BORDER TYPE: FLUSH
 RECESS: 0"
 WIDTH: 2"
 RADII: 12"
 NO. Z BARS: 3
 LENGTH: 196.0"

USE NOTES: 1,3,5
 1. Legend and border shall be direct applied Grade A reflective sheeting.
 2. Legend and border shall be direct applied Grade C reflective sheeting.
 3. Shields shall be Grade A reflective sheeting on 0.032" aluminum and demountable.
 4. Background shall be Grade B reflective sheeting.
 5. Background shall be Grade C reflective sheeting.
 6. Center arrow(s) vertically on sign.



Letter spacings are to start of next letter

Series/Size	Text Length
EM 2000	93.8
EM 2000	120.6

Spacing Factor is 1 unless specified otherwise
 FILENAME: GSENG

OVERHEAD SIGN DESIGNS

TIP NO. R-2719AA	SHEET NO. SIGN-4H
APPROVED: <i>[Signature]</i>	
DATE: 2/21/12	
SEAL	

SIGN NUMBER: 101,102 TYPE: A QUANTITY: 2 SIGN WIDTH: 21'-6" HEIGHT: 12'-6" TOTAL AREA: 268.8 Sq.Ft. BORDER TYPE: FLUSH RECESS: 0" WIDTH: 2" RADIUS: 12" NO. Z BARS: 4 LENGTH: 250.0	BACKG. COLOR: Green COPY COLOR: White SYMBOL X Y WID HT M1-5-3-36-12D 79.4 97.4 36 36	DESIGN BY: D.P. PROJECT ID: R-2719AA CHECKED BY: AIA DIV: 2 DATE: July 18, 2011
--	---	---

USE NOTES: 1,2,3,4
1. Legend and border shall be direct applied Grade C sheeting.
2. Background shall be Grade C reflective sheeting.
3. Shields shall be on 0.032" (0.8mm) aluminum and demountable.
4. Shields shall be Grade C sheeting.

LETTER POSITIONS
Letter locations are panel edge to lower left corner

Letter	Series/Size	Text Length
E A S T	E 2000	47.9
C F H A R V E Y P K W Y	EM 2000	223
G I O B A I T R A N S P A R K	EM 2000	219.2
E X I T	E 2000	30.6
M I L E	E 2000	33.1
1	E 2000	4.5

FILENAME: Signs_OverheadR2719AA NORTH CAROLINA D.O.T. SIGN DETAIL

SIGN NUMR: 105 TYPE: A Ground QUANTITY: 1 SIGN WIDTH: 13'-6" HEIGHT: 12'-6" TOTAL AREA: 168.8 Sq.Ft. BORDER TYPE: FLUSH RECESS: 0" WIDTH: 2" RADIUS: 12" NO. Z BARS: 4 LENGTH: 154.0 "	BACKG. COLOR: Green COPY COLOR: White SYMBOL X Y WID HT M1_4 63 96 36 36	DESIGN BY: DME PROJECT ID: R-2719AA CHK BY: DIV: 2 STD #: SSTN DATE: Feb 15, 2012
---	--	--

USE NOTES: 2,3,6
1. Legend and border shall be direct applied Grade A reflective sheeting.
2. Legend and border shall be direct applied Grade C reflective sheeting.
3. Shields shall be Grade A reflective sheeting on 0.032" aluminum and demountable.
4. Background shall be Grade B reflective sheeting.
5. Background shall be Grade C reflective sheeting.
6. Center arrow(s) vertically on sign.

LETTER POSITIONS
Letter spacings are to start of next letter

Letter	Series/Size	Text Length
K I N S T O N	EM 2000	93.8
G O L D S B O R O	EM 2000	122.2
E X I T 1 M I L E	E 2000	98.2

Spacing Factor is 1 unless specified otherwise
FILENAME: GSENG

SIGN NUMBER: 103 TYPE: A QUANTITY: 1 SIGN WIDTH: 26'-0" HEIGHT: 10'-6" TOTAL AREA: 273.0 Sq.Ft. BORDER TYPE: FLUSH RECESS: 0" WIDTH: 2" RADIUS: 12" NO. Z BARS: 3 LENGTH: 304.0	BACKG. COLOR: Green COPY COLOR: White SYMBOL X Y WID HT M1-5-3-36-12D 81.2 73.2 36 36 ARMED 265.1 28.3 22.5 35.4	DESIGN BY: D.P. PROJECT ID: R-2719AA CHECKED BY: AIA DIV: 2 DATE: July 18, 2011
--	---	---

USE NOTES: 1,2,3,4
1. Legend and border shall be direct applied Grade C sheeting.
2. Background shall be Grade C reflective sheeting.
3. Shields shall be on 0.032" (0.8mm) aluminum and demountable.
4. Shields shall be Grade C sheeting.

LETTER POSITIONS
Letter locations are panel edge to lower left corner

Letter	Series/Size	Text Length
E A S T	E 2000	47.9
C F H A R V E Y P K W Y	EM 2000	223
G I O B A I T R A N S P A R K	EM 2000	219.2

FILENAME: Signs_OverheadR2719AA NORTH CAROLINA D.O.T. SIGN DETAIL

SIGN NUMBER: 104 TYPE: A QUANTITY: 1 SIGN WIDTH: 13'-0" HEIGHT: 12'-6" TOTAL AREA: 162.5 Sq.Ft. BORDER TYPE: FLUSH RECESS: 0" WIDTH: 2" RADIUS: 12" NO. Z BARS: 4 LENGTH: 148.0	BACKG. COLOR: Green COPY COLOR: White SYMBOL X Y WID HT M1_4 55.7 97.2 45.4 36	DESIGN BY: D.P. PROJECT ID: R-2719AA CHECKED BY: AIA DIV: 2 DATE: July 18, 2011
--	--	---

USE NOTES: 1,2,3,4
1. Legend and border shall be direct applied Grade C sheeting.
2. Background shall be Grade C reflective sheeting.
3. Shields shall be on 0.032" (0.8mm) aluminum and demountable.
4. Shields shall be Grade C sheeting.

LETTER POSITIONS
Letter locations are panel edge to lower left corner

Letter	Series/Size	Text Length
K I N S T O N	EM 2000	93.8
S N O W H I L L	EM 2000	120.6
E X I T	E 2000	30.6
M I L E	E 2000	33.1
1	E 2000	4.5

FILENAME: Signs_OverheadR2719AA NORTH CAROLINA D.O.T. SIGN DETAIL

GROUND MOUNTED SIGN DESIGNS

TIP NO. R-2719AA	SHEET NO. SIGN-41
APPROVED: <i>[Signature]</i>	
DATE: 2/21/12	
SEAL	

SIGN NUMB: 203A BACKG. COLOR: Green DESIGN BY: DME CHK BY: STD #: S\$TN N. C. DEPARTMENT OF TRANSPORTATION
 TYPE: A Ground COPY COLOR: White PROJECT ID: R-2719AA DIV: 2 DATE: Feb 07, 2012 DIVISION OF HIGHWAYS
 QUANTITY: 1 TRAFFIC ENGINEERING BRANCH
 SIGNING DEPARTMENT

SIGN WIDTH: 6'-0"
 HEIGHT: 5'-0"
 TOTAL AREA: 30.0 Sq.Ft.

SYMBOL	X	Y	WID	HT
AR_Type A	22.8	8.8	18.3	28.7

MAT'L: 0.125" ALUMINUM

BORDER TYPE: FLUSH
 RECESS: 0"
 WIDTH: 1.5"
 RADII: 8"
 NO. Z BARS: 2
 LENGTH: 64.0"

USE NOTES: 2,5
 1. Legend and border shall be direct applied Grade A reflective sheeting.
 2. Legend and border shall be direct applied Grade C reflective sheeting.
 3. Shields shall be Grade A reflective sheeting on 0.032" aluminum and demountable.
 4. Background shall be Grade B reflective sheeting.
 5. Background shall be Grade C reflective sheeting.
 6. Center arrow(s) vertically on sign.

BORDER R=8" TH=1.5"

Letter spacings are to start of next letter						Series/Size	
	E	X	I	T		Text Length	
	12	13.8	17.3	8	9	12	E 2000
							48

Spacing Factor is 1 unless specified otherwise
 FILENAME: GSENG

SIGN NUMBER: 301 BACKG. COLOR: Green DESIGN BY: D.P. CHECKED BY: AXA DATE: July 18, 2011
 TYPE: D COPY COLOR: White PROJECT ID: R-2719AA DIV: 2

QUANTITY: 1

SYMBOL	X	Y	WID	HT
ARUP	66.5	25.8	8	12
ARUP	9	8.1	8	12

SIGN WIDTH: 8'-0"
 HEIGHT: 3'-0"
 TOTAL AREA: 28.0 Sq.Ft.

BORDER TYPE: FLUSH
 RECESS: 0"
 WIDTH: 0.75"
 RADII: 3"
 NO. Z BARS: 1
 LENGTH: 95.8"

MAT'L: 0.125" (3.2 mm) ALUMINUM

USE NOTES: 1,2
 1. Legend and border(except those that are colored black) shall be direct applied Grade C sheeting.
 2. Background shall be Grade C reflective sheeting.

BORDER R=3" TH=0.75"

Letter locations are panel edge to lower left corner											Series/Size
K	i	n	s	t	o	n					Text Length
16.6	23.4	26.3	32	36.1	39.9	46					D 2000
											34.2
S	n	o	w	H	i	l					Text Length
29	35.7	41.6	47.1	56.2	64.2	71.4	74.2	77.1			D 2000
											48.4

Spacing Factor is 1 unless specified otherwise
 FILENAME: Sign_OverheadR2719AA
 NORTH CAROLINA D.O.T. SIGN DETAIL

SIGN NUMB: 203B BACKG. COLOR: Yellow DESIGN BY: DME CHK BY: STD #: S\$TN N. C. DEPARTMENT OF TRANSPORTATION
 TYPE: B Ground COPY COLOR: Black PROJECT ID: R-2719AA DIV: 2 DATE: Feb 07, 2012 DIVISION OF HIGHWAYS
 QUANTITY: 1 TRAFFIC ENGINEERING BRANCH
 SIGNING DEPARTMENT

SIGN WIDTH: 6'-0"
 HEIGHT: 2'-0"
 TOTAL AREA: 12.0 Sq.Ft.

SYMBOL	X	Y	WID	HT

MAT'L: 0.125" ALUMINUM

BORDER TYPE: FLUSH
 RECESS: 0.5"
 WIDTH: 1"
 RADII: 3"
 NO. Z BARS: 2
 LENGTH: 64.0"

USE NOTES: 1,5
 1. Legend and border shall be direct applied Non-reflective sheeting.
 2. Legend and border shall be direct applied Grade C reflective sheeting.
 3. Shields shall be Grade A reflective sheeting on 0.032" aluminum and demountable.
 4. Background shall be Grade B reflective sheeting.
 5. Background shall be Grade C reflective sheeting.
 6. Center arrow(s) vertically on sign.

BORDER R=3" TH=1" IN=0.5"

Letter spacings are to start of next letter										Series/Size
	4	5	M	P	H					Text Length
	6.4	11.1	8.1	10	12	9.8	8.1	6.5		E 2000
										59.1

Spacing Factor is 1 unless specified otherwise
 FILENAME: GSENG

GROUND MOUNTED SIGN DESIGNS

TIP NO. R-2719AA	SHEET NO. SIGN-4J
APPROVED: <i>[Signature]</i>	
DATE: 2/2/12	
SEAL	



SIGN NUMBER: 201,202,204 TYPE: A QUANTITY: 3 SIGN WIDTH: 5'-0" HEIGHT: 5'-0" TOTAL AREA: 25.0 Sq.Ft. BORDER TYPE: FLUSH RECESS: 0" WIDTH: 1.5" RADII: 8" NO. Z BARS: 2 LENGTH: 52.0	BACKG COLOR: Green COPY COLOR: White SYMBOL	DESIGN BY: D.P. PROJECT ID: R-2719AA	CHECKED BY: AIA DIV: 2	DATE: July 18, 2011
--	---	---	---------------------------	---------------------

SYMBOL	X	Y	WID	HT
ARMED	18.4	6	18.7	29.5

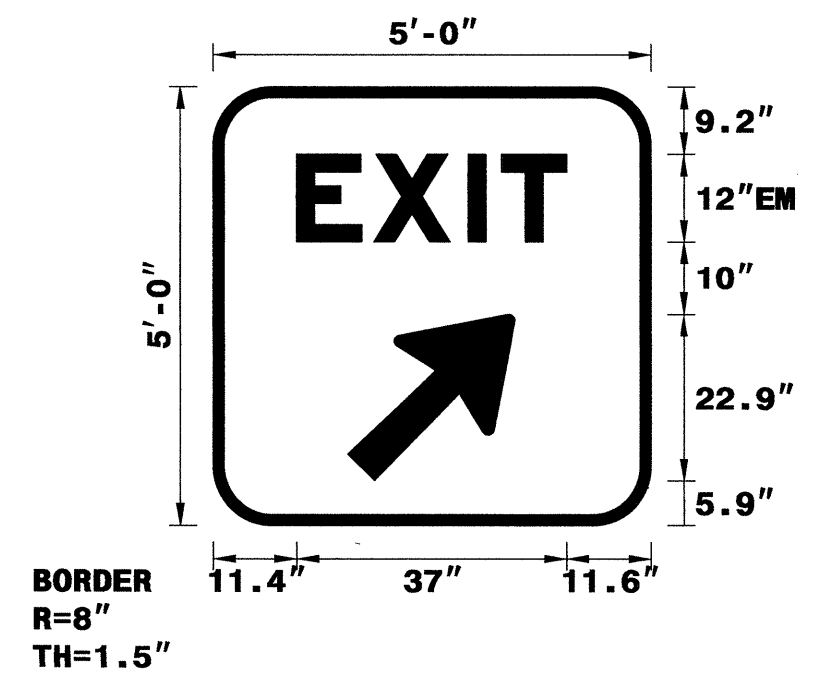

USE NOTES: 1,2
1. Legend and border(except those that are colored black) shall be direct applied Grade C sheeting.
2. Background shall be Grade C reflective sheeting.

LETTER POSITIONS					Series/Size	Text Length
Letter locations are panel edge to lower left corner					EM	2000
E	X	I	T			37
11.4	22	35	39.5			

FILENAME: Signs_OverheadsR2719AA NORTH CAROLINA D.O.T. SIGN DETAIL

SIGN NUMBER: 421 TYPE: E QUANTITY: 2 SIGN WIDTH: 2'-0" HEIGHT: 1'-6" TOTAL AREA: 3.0 Sq.Ft. BORDER TYPE: FLUSH RECESS: 0.4" WIDTH: 0.62" RADII: 1.5" NO. Z BARS: LENGTH:	BACKG COLOR: White COPY COLOR: Black SYMBOL	DESIGN BY: D.P. PROJECT ID: R-2719AA	CHECKED BY: AIA DIV: 2	DATE: July 18, 2011
---	---	---	---------------------------	---------------------

SYMBOL	X	Y	WID	HT

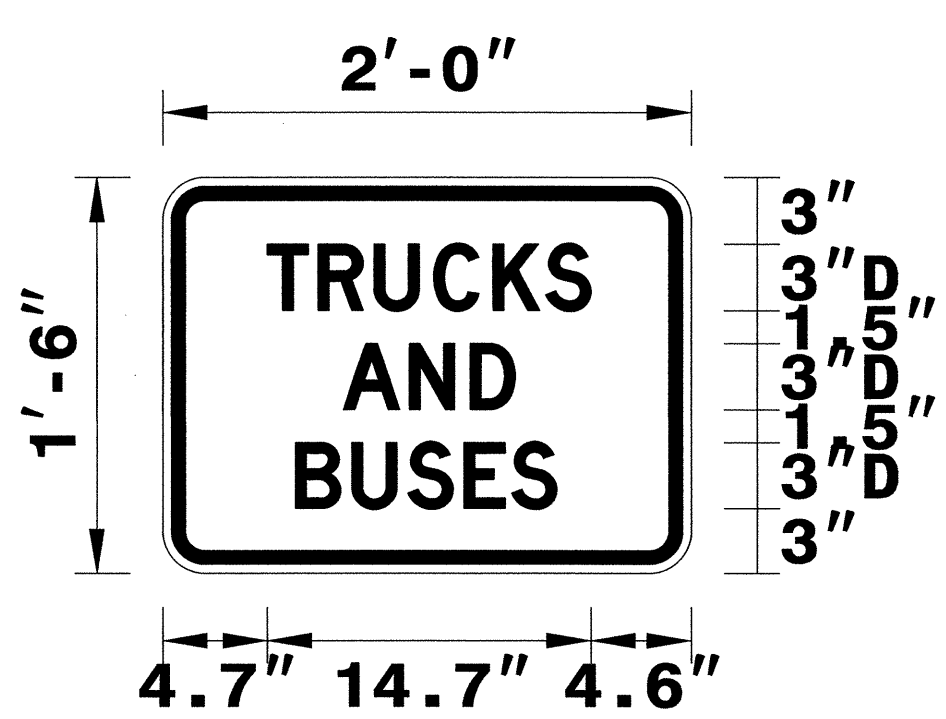

USE NOTES: 1,2
1. Legend and border(except those that are colored black) shall be direct applied Grade C sheeting.
2. Background shall be Grade C reflective sheeting.

BORDER
R=1.5"
TH=0.62"
IN=0.4"

LETTER POSITIONS					Series/Size	Text Length
Letter locations are panel edge to lower left corner					D	2000
T	R	U	C	K	S	14.7
4.7	7.1	9.6	12.3	15	17.4	
A	N	D				7.8
8.2	11.2	14				
B	U	S	E	S		11.9
6	8.6	11.1	13.7	15.8		

FILENAME: Signs_OverheadsR2719AA NORTH CAROLINA D.O.T. SIGN DETAIL

GROUND MOUNTED SIGN DESIGNS

TIP NO. R-2719AA	SHEET NO. SIGN-5
APPROVED: <i>[Signature]</i>	
DATE: 2/21/12	
SEAL	

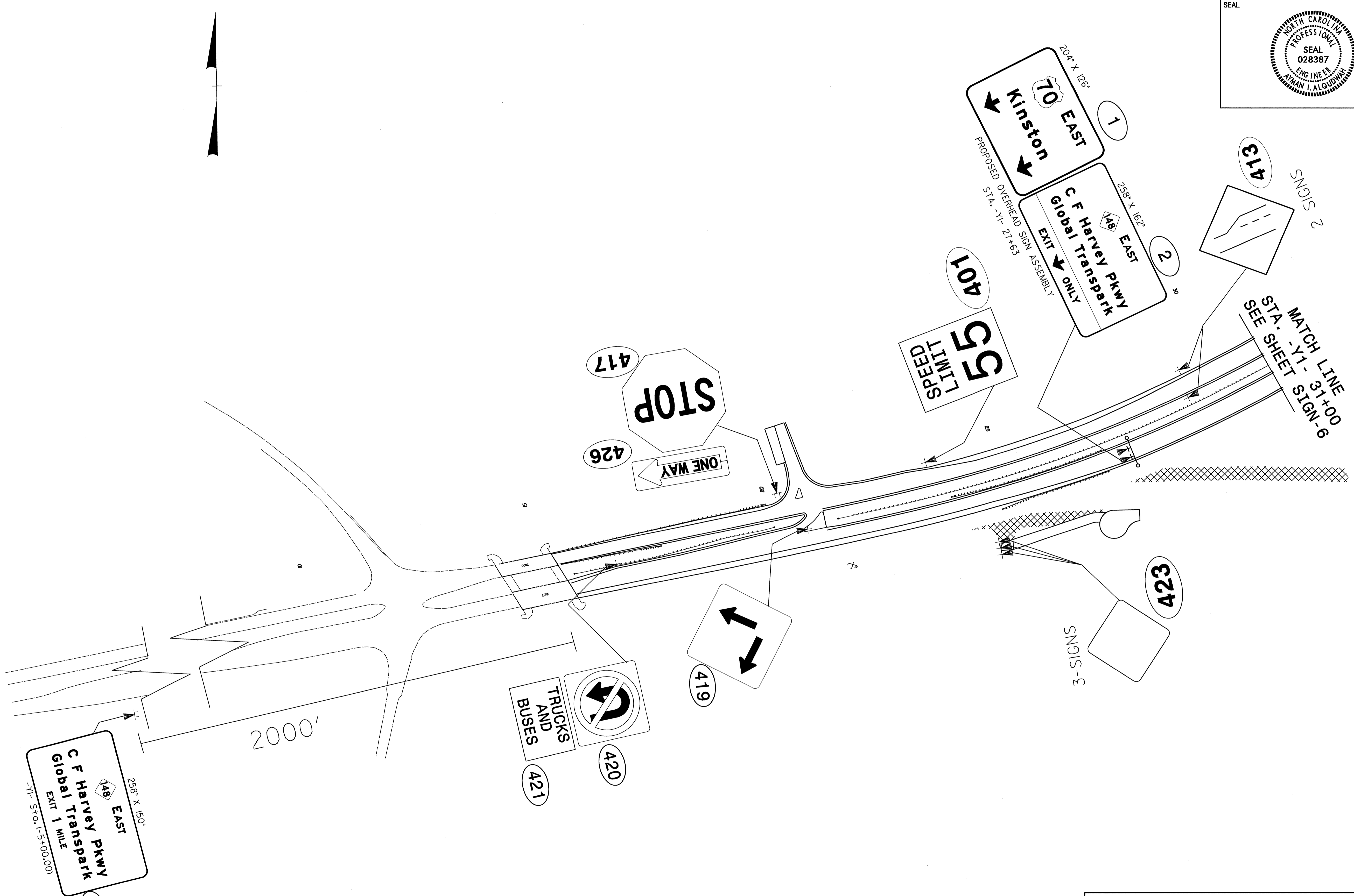

PROPOSED SIGNS
-Y1- STA. -5+00 TO STA 31+00

TIP NO. R-2719AA	SHEET NO. SIGN-6
APPROVED: <i>[Signature]</i>	
DATE: 2/21/12	
SEAL	

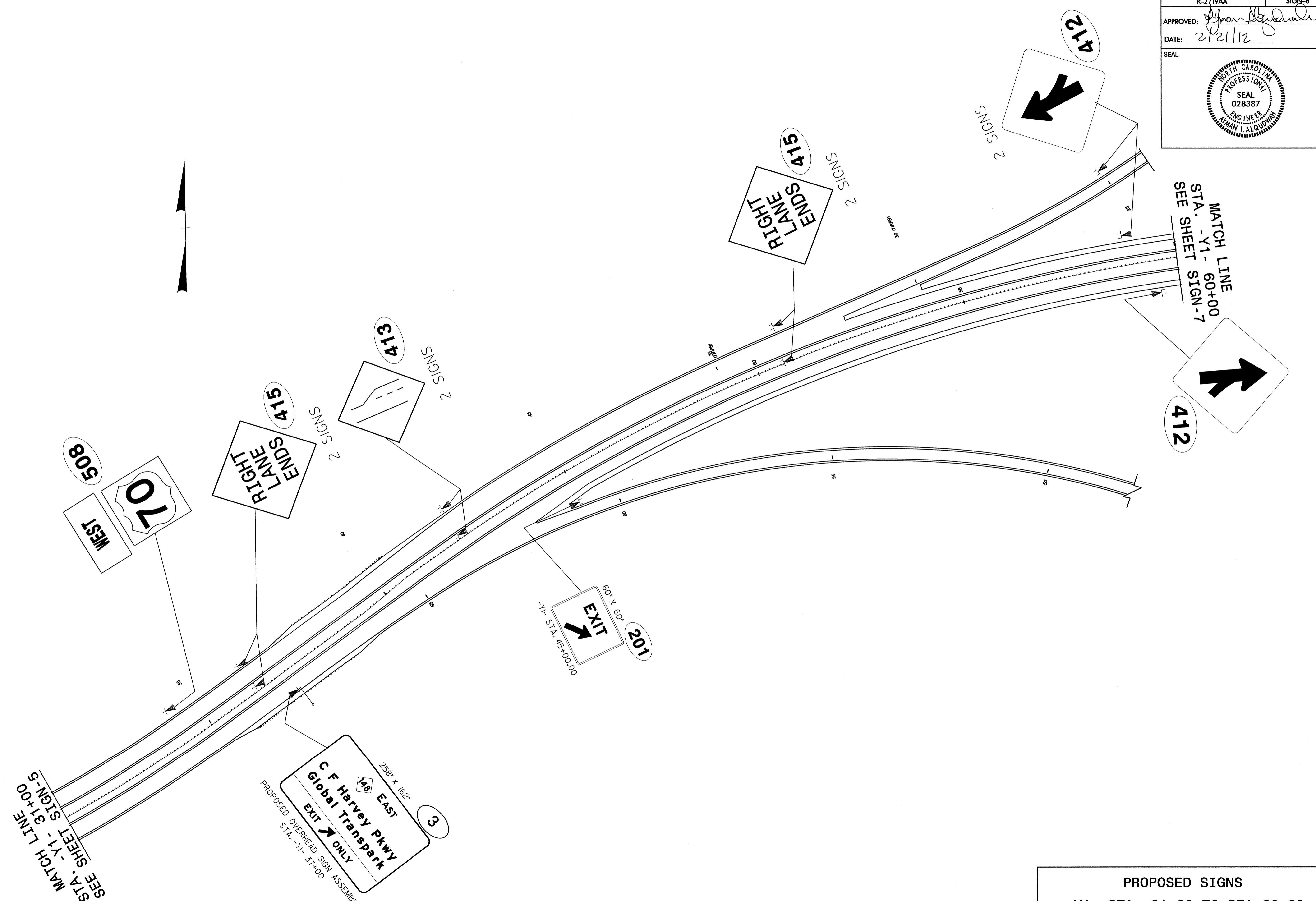

PROPOSED SIGNS
-Y1- STA. 31+00 TO STA 60+00

TIP NO. R-2719AA	SHEET NO. SIGN-7
APPROVED: <i>[Signature]</i>	
DATE: 2/21/12	
SEAL	

MATCH LINE
STA. -L- 65+00
SEE SHEET SIGN-10

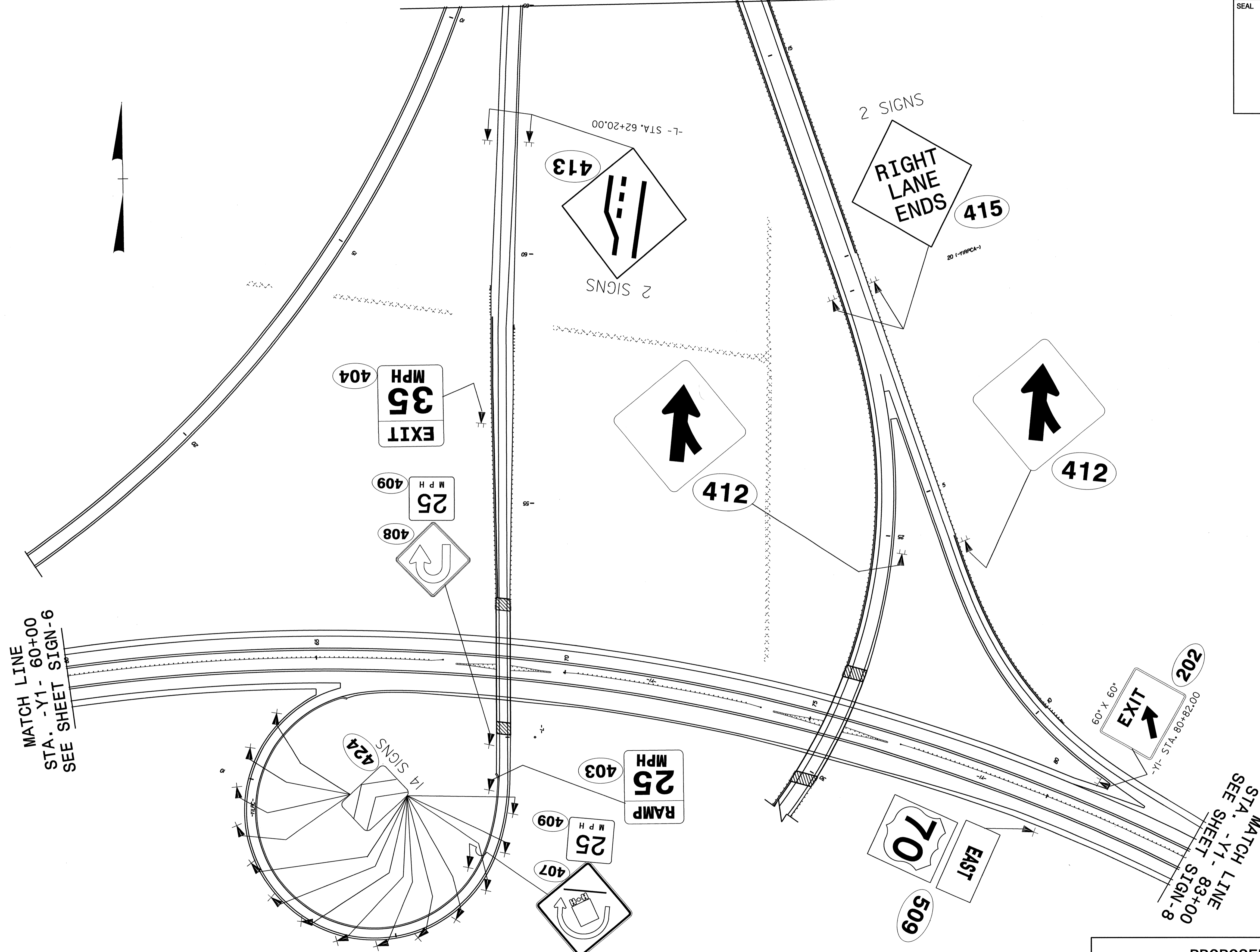

MATCH LINE
STA. -Y1- 60+00
SEE SHEET SIGN-6

MATCH LINE
STA. -Y1- 83+00
SEE SHEET SIGN-8

PROPOSED SIGNS
-Y1- STA. 60+00 TO STA 83+00

TIP NO. R-2719AA	SHEET NO. SIGN-9
APPROVED: <i>[Signature]</i>	
DATE: 2/21/12	
SEAL	

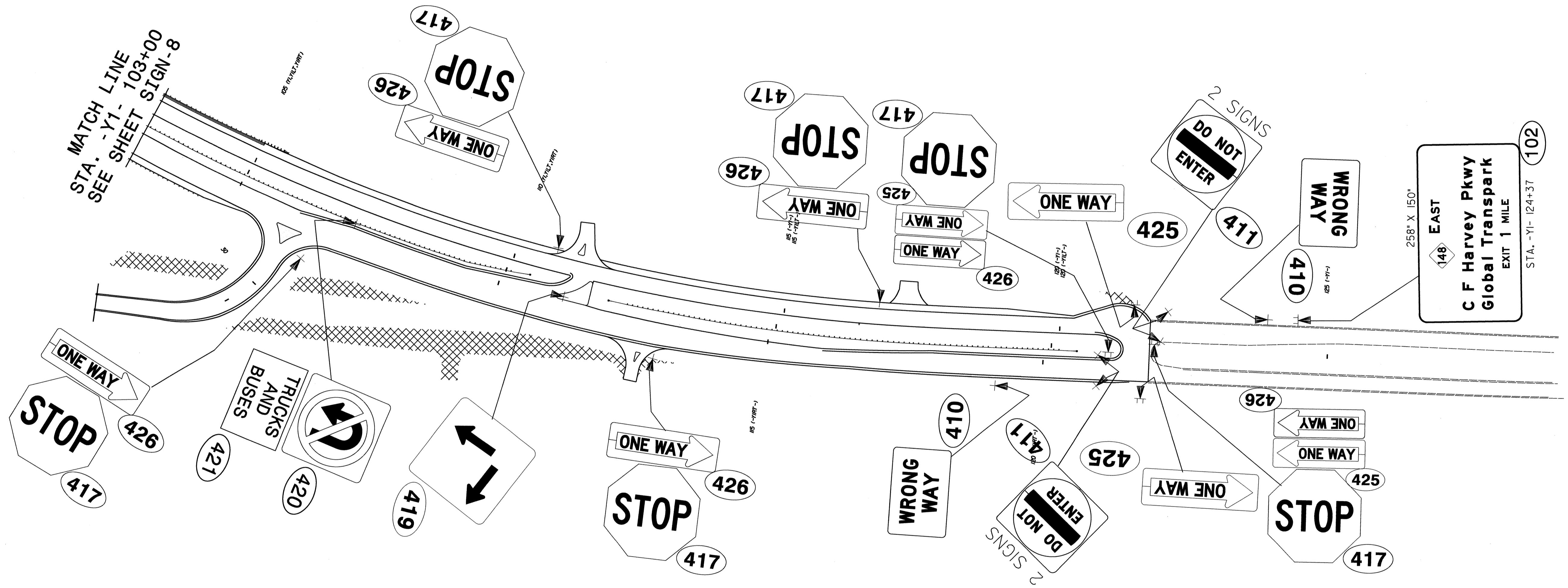
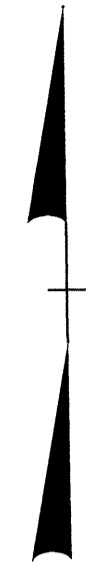

PROPOSED SIGNS
-Y1- STA. 83+00 TO STA 103+00

TIP NO. R-2719AA	SHEET NO. SIGN-10
APPROVED: <i>[Signature]</i>	
DATE: 2/21/12	
SEAL	
	

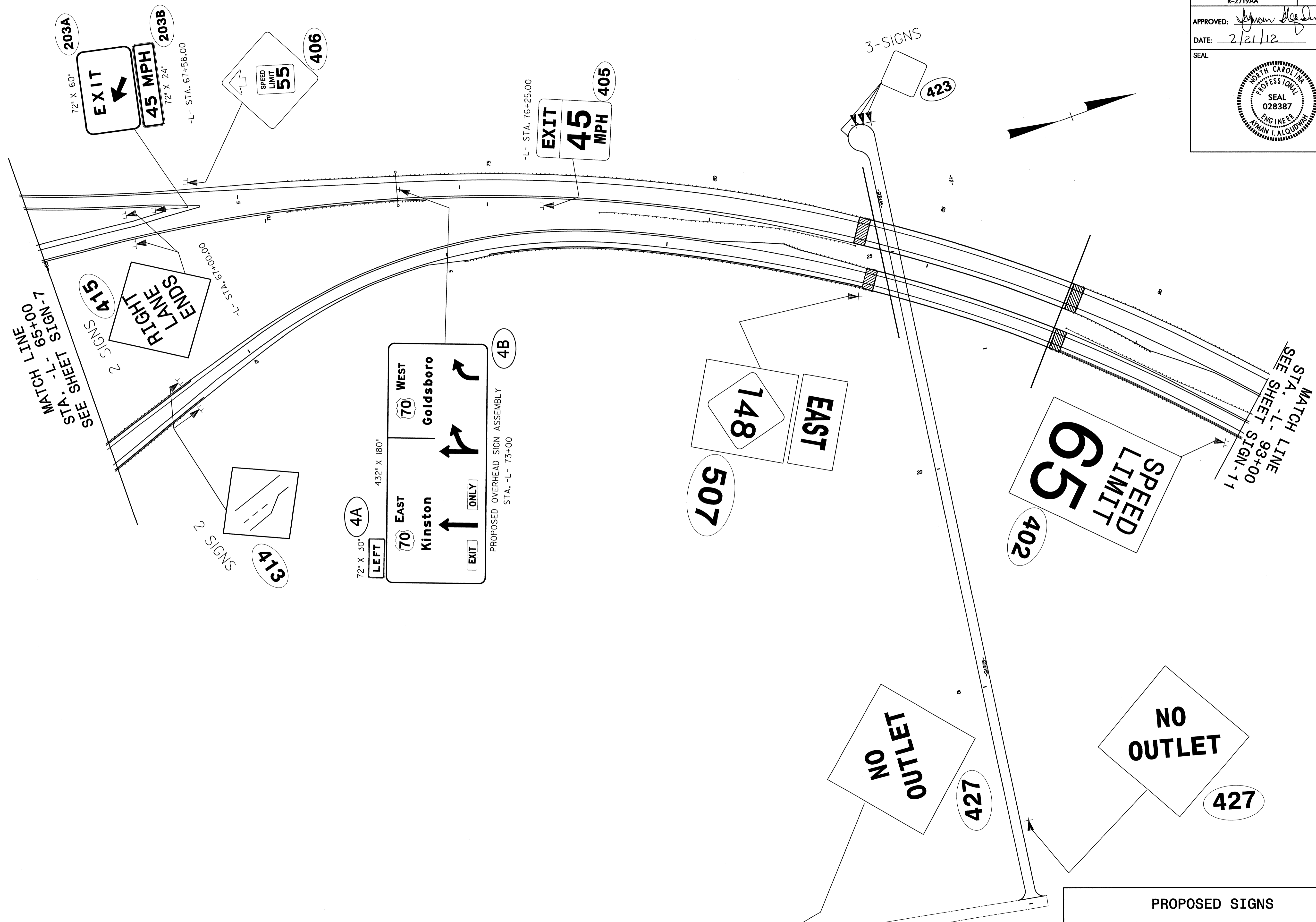

PROPOSED SIGNS
-L- STA. 65+00 TO STA 93+00

TIP NO. R-2719AA	SHEET NO. SIGN-11
APPROVED: <i>[Signature]</i>	
DATE: 2/21/12	
SEAL	



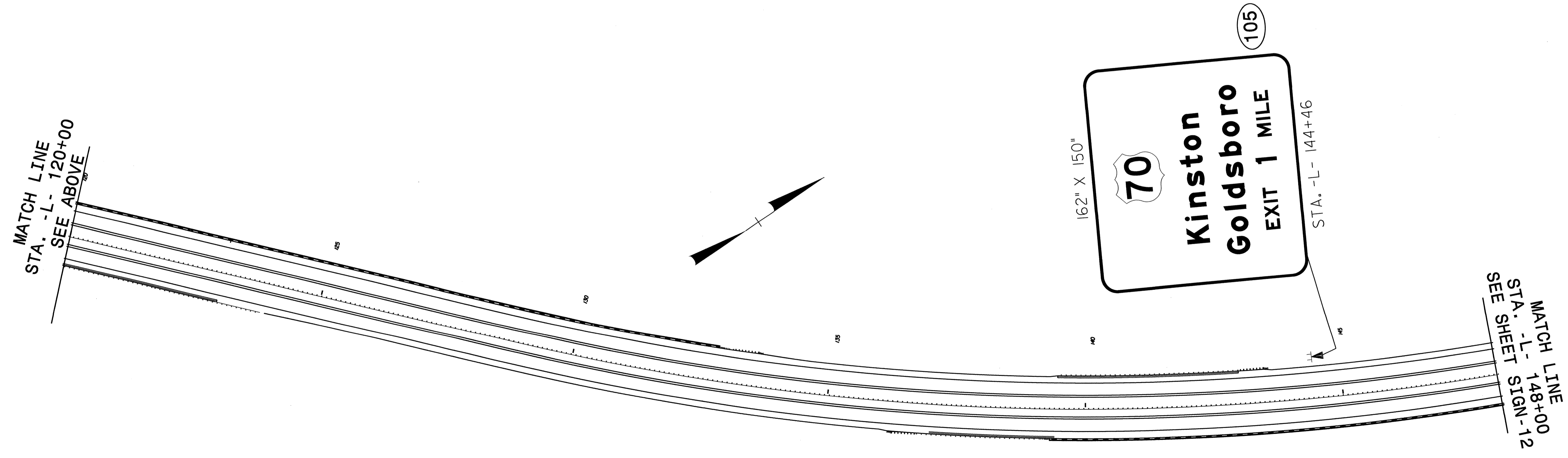
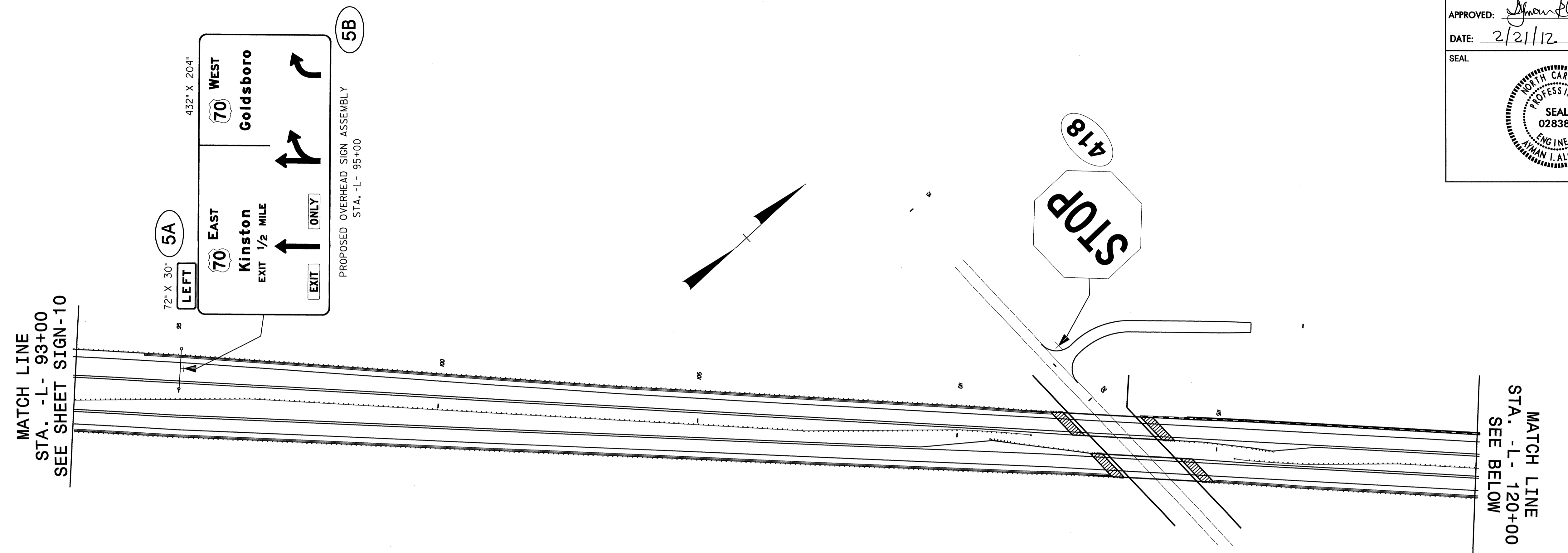

PROPOSED SIGNS
-L- STA. 93+00 TO STA 148+00

TIP NO. R-2719AA	SHEET NO. SIGN-12
APPROVED: <i>[Signature]</i>	
DATE: 2/21/12	
SEAL	

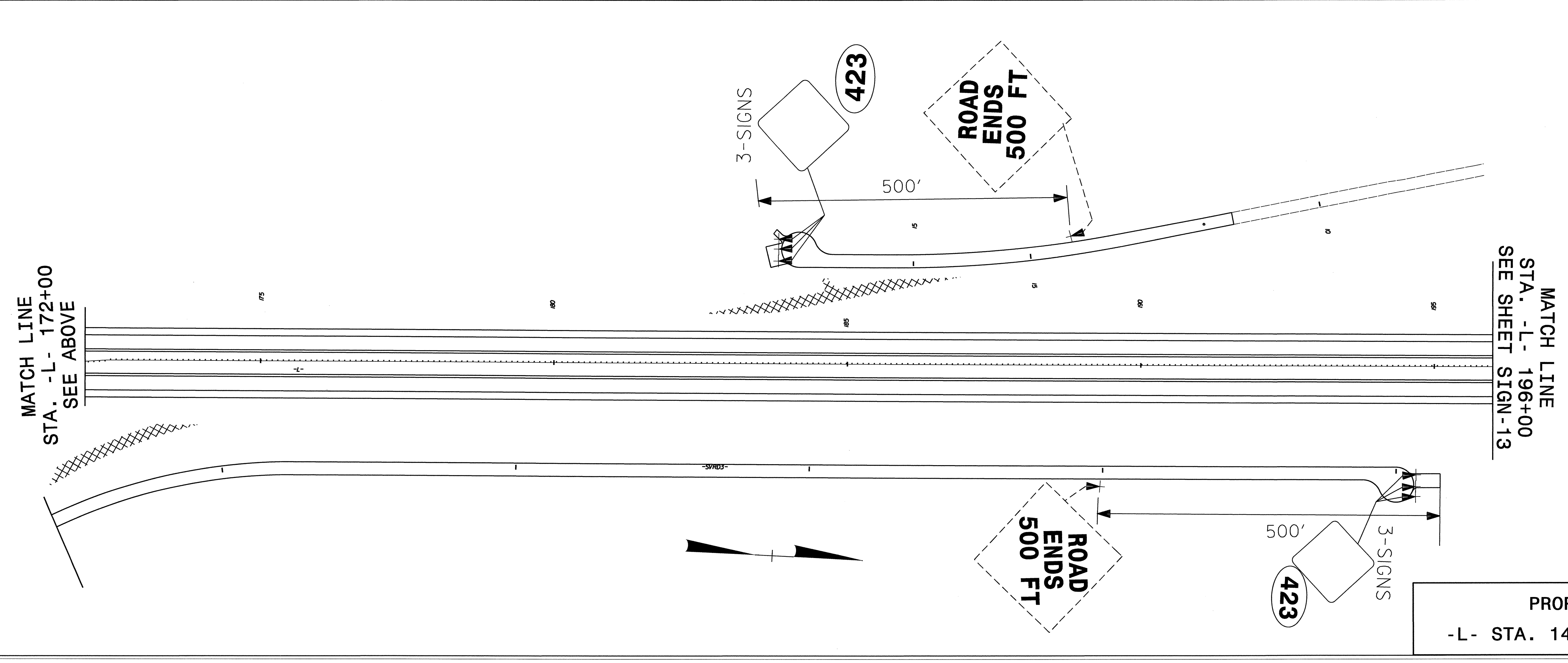
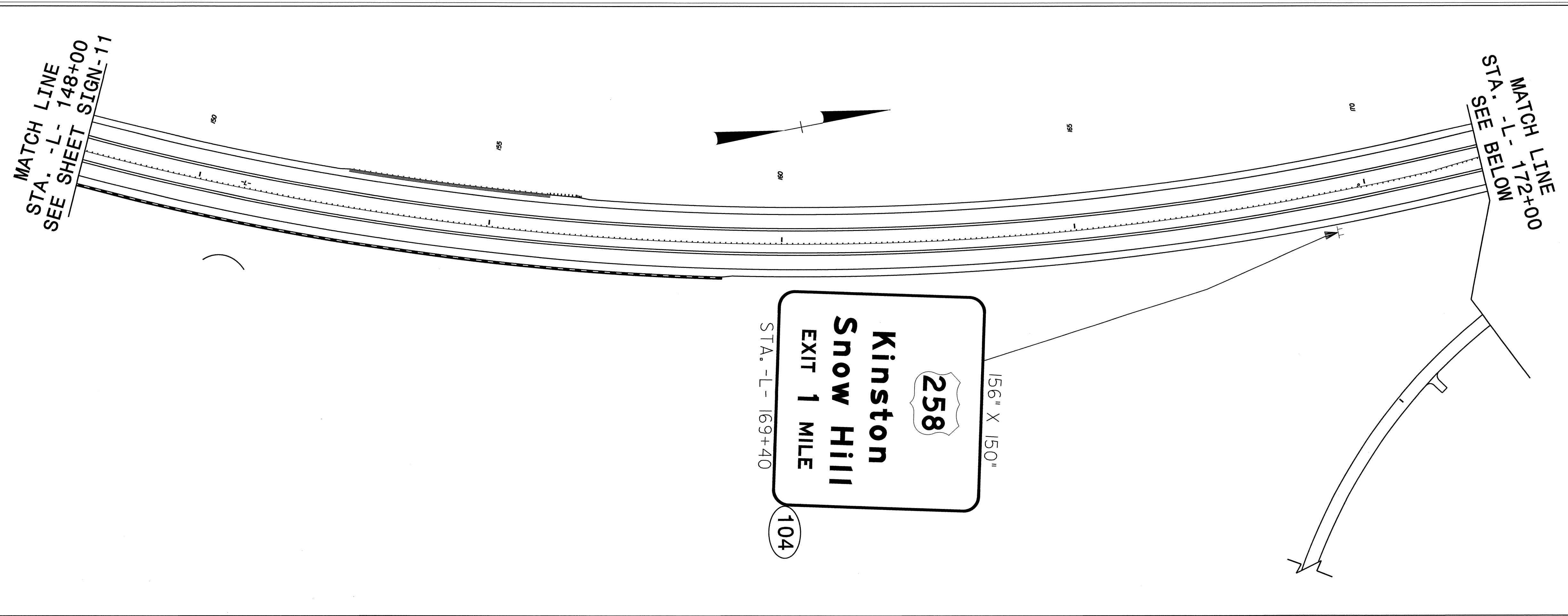

PROPOSED SIGNS
-L- STA. 148+00 TO STA 196+00

TIP NO. R-2719AA	SHEET NO. SIGN-13
APPROVED: <i>Hyman Alqudwini</i>	
DATE: 2/21/12	
SEAL	

MATCH LINE
STA. -L- 196+00
SEE SHEET SIGN-12

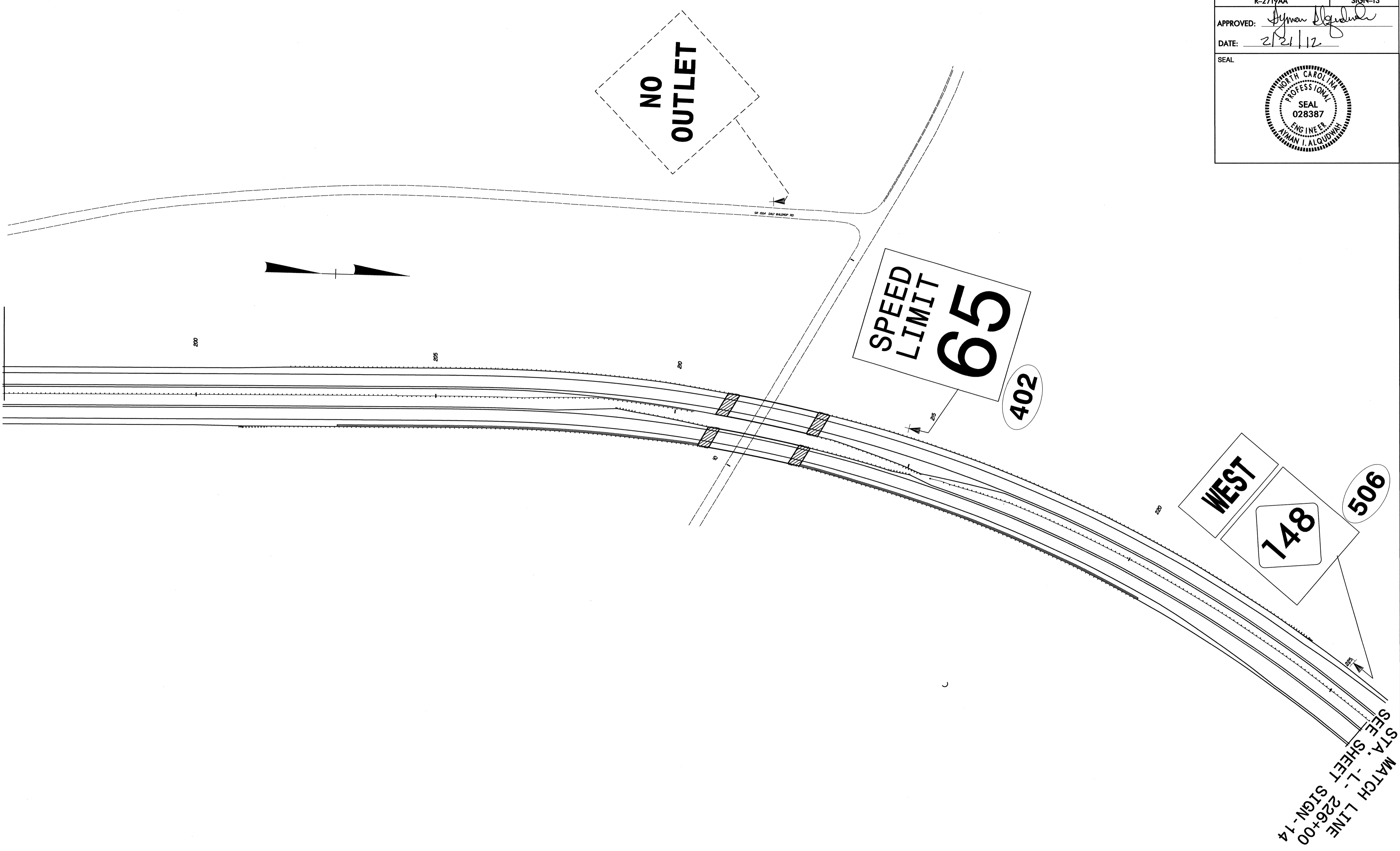

STA. -L- 226+00
MATCH LINE
SEE SHEET SIGN-14

PROPOSED SIGNS
-L- STA. 196+00 TO STA 226+00

- Pay Item/Construction Notes**
- DISPOSAL OF SIGN, A OR B (GROUND MOUNTED)
*REMOVE ONLY THE "ALL TRAFFIC EXIT" SIGN
 - DISPOSAL OF SIGN SYSTEM, WOOD
 - SIGN ERECTION, RELOCATE SIGN TYPE E

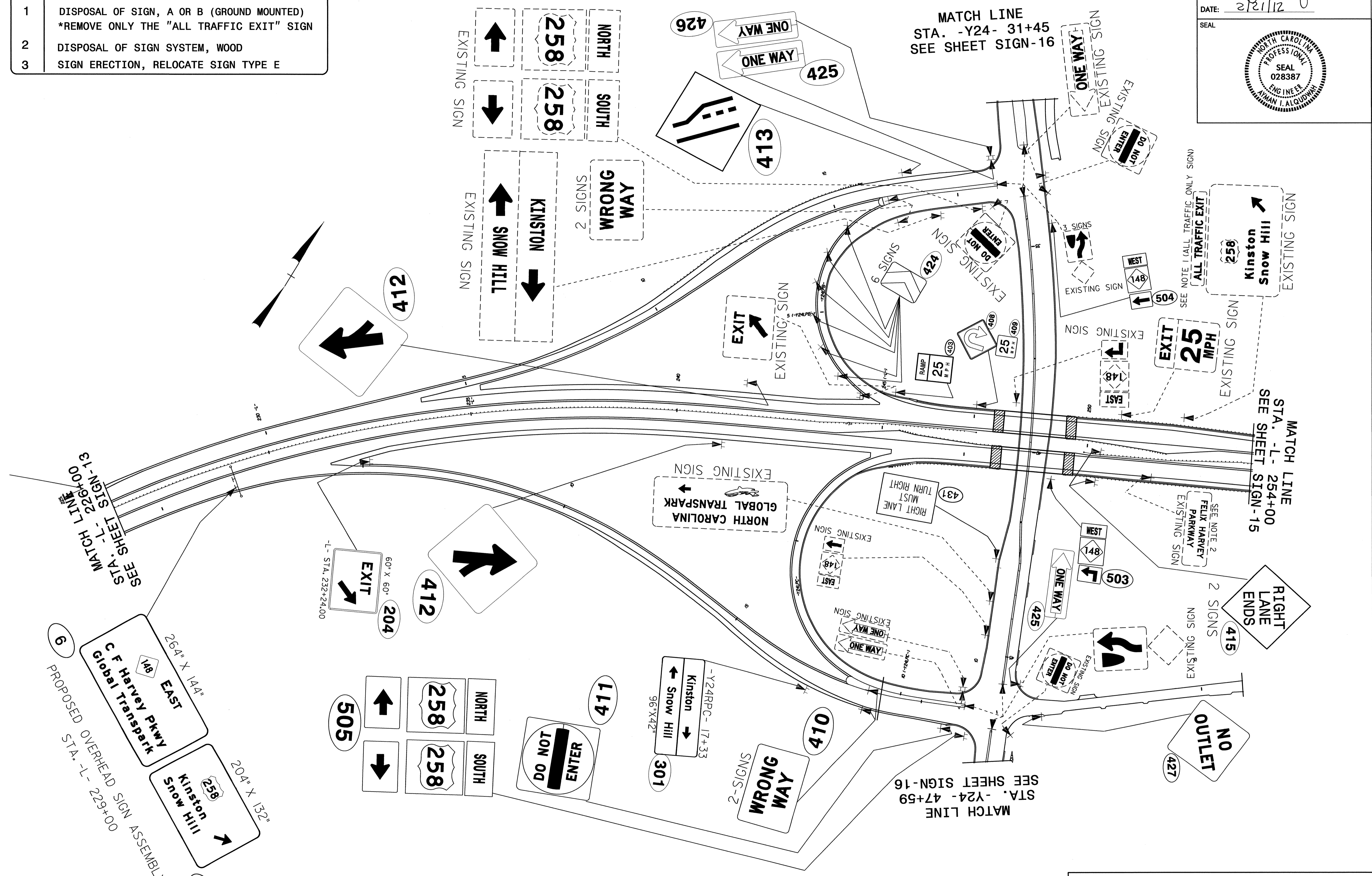

MATCH LINE
SEE SHEET SIGN-13
STA. -L- 229+00

264" X 144" EAST
148
C F Harvey Pkwy
Global Transpark

204" X 132" Kinston
258
III Snow Hill

PROPOSED OVERHEAD SIGN ASSEMBLY
STA. -L- 229+00

MATCH LINE
STA. -Y24- 31+45
SEE SHEET SIGN-16

MATCH LINE
STA. -L- 254+00
SEE SHEET SIGN-15

MATCH LINE
STA. -Y24- 47+59
SEE SHEET SIGN-16

PROPOSED SIGNS
-L- STA. 226+00 TO STA 254+00

TIP NO. R-2719AA	SHEET NO. SIGN-15
APPROVED: <i>[Signature]</i>	
DATE: 2/21/12	
SEAL	

Pay Item/Construction Notes	
1	DISPOSAL OF SIGN, A OR B (GROUND MOUNTED) *REMOVE ONLY THE "ALL TRAFFIC EXIT" SIGN
2	DISPOSAL OF SIGN SYSTEM, WOOD
3	SIGN ERECTION, RELOCATE SIGN TYPE E

MATCH LINE
STA. -L- 254+00
SEE SHEET SIGN-14

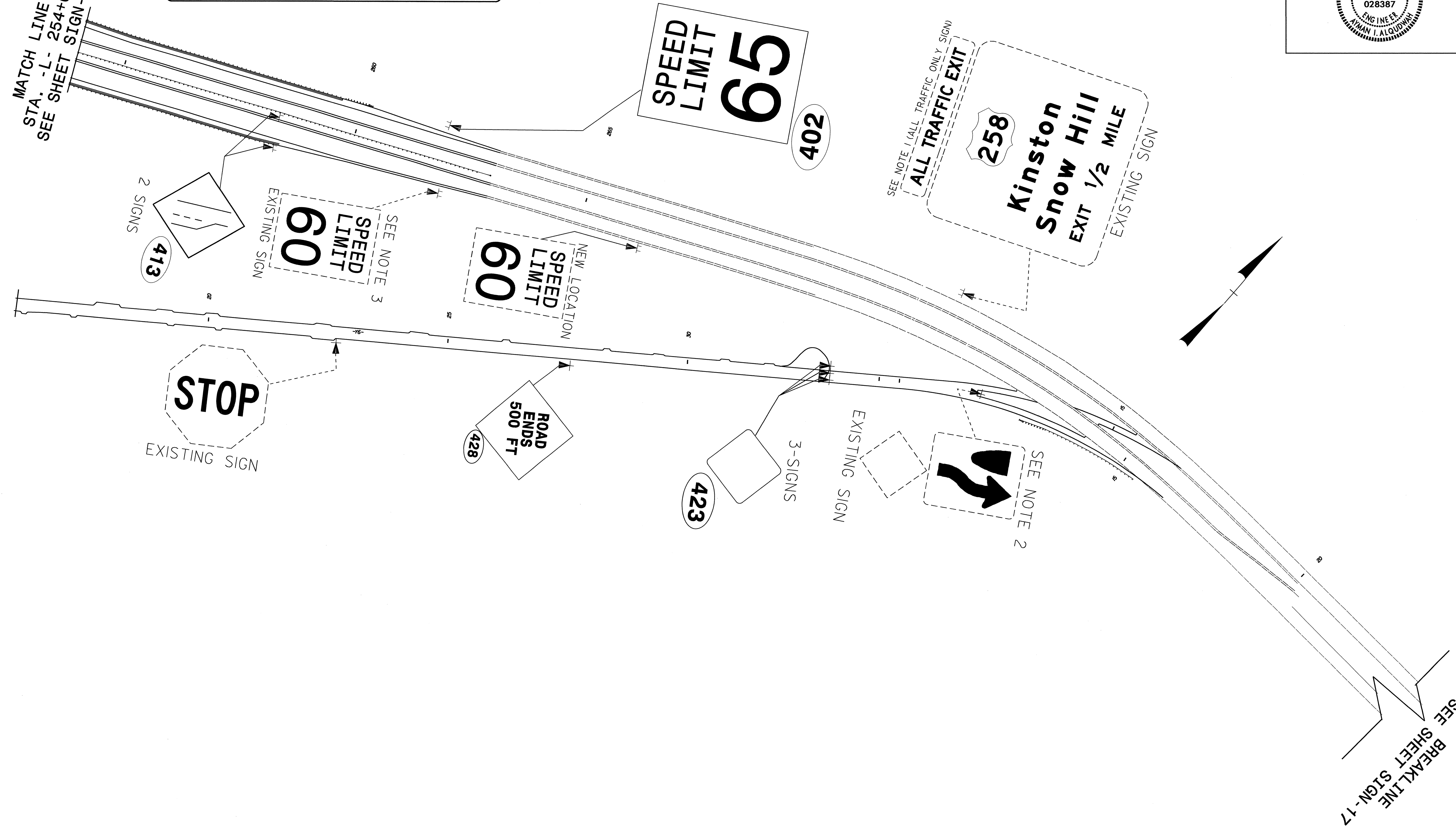

2 SIGNS
413

EXISTING SIGN
SPEED LIMIT 60
SEE NOTE 3

NEW LOCATION
SPEED LIMIT 60

STOP
EXISTING SIGN

ROAD ENDS 500 FT
428

3-SIGNS
423

EXISTING SIGN
SEE NOTE 2

SEE NOTE 1 (ALL TRAFFIC ONLY SIGN)
ALL TRAFFIC EXIT
258
Kinston
Snow Hill
EXIT 1/2 MILE
EXISTING SIGN

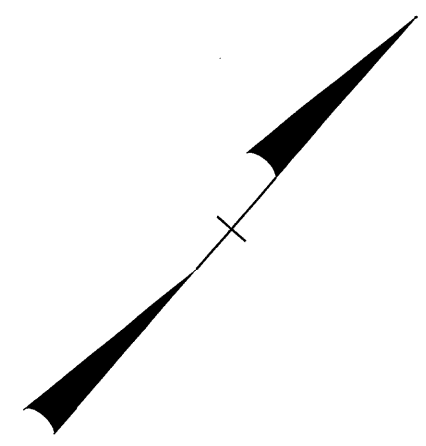

SEE BREAKLINE
SIGN-17

PROPOSED SIGNS
-L- STA. 196+00 TO STA 226+00

TIP NO. R-2719AA	SHEET NO. SIGN-16
APPROVED: <i>[Signature]</i>	
DATE: 2/21/12	
SEAL	

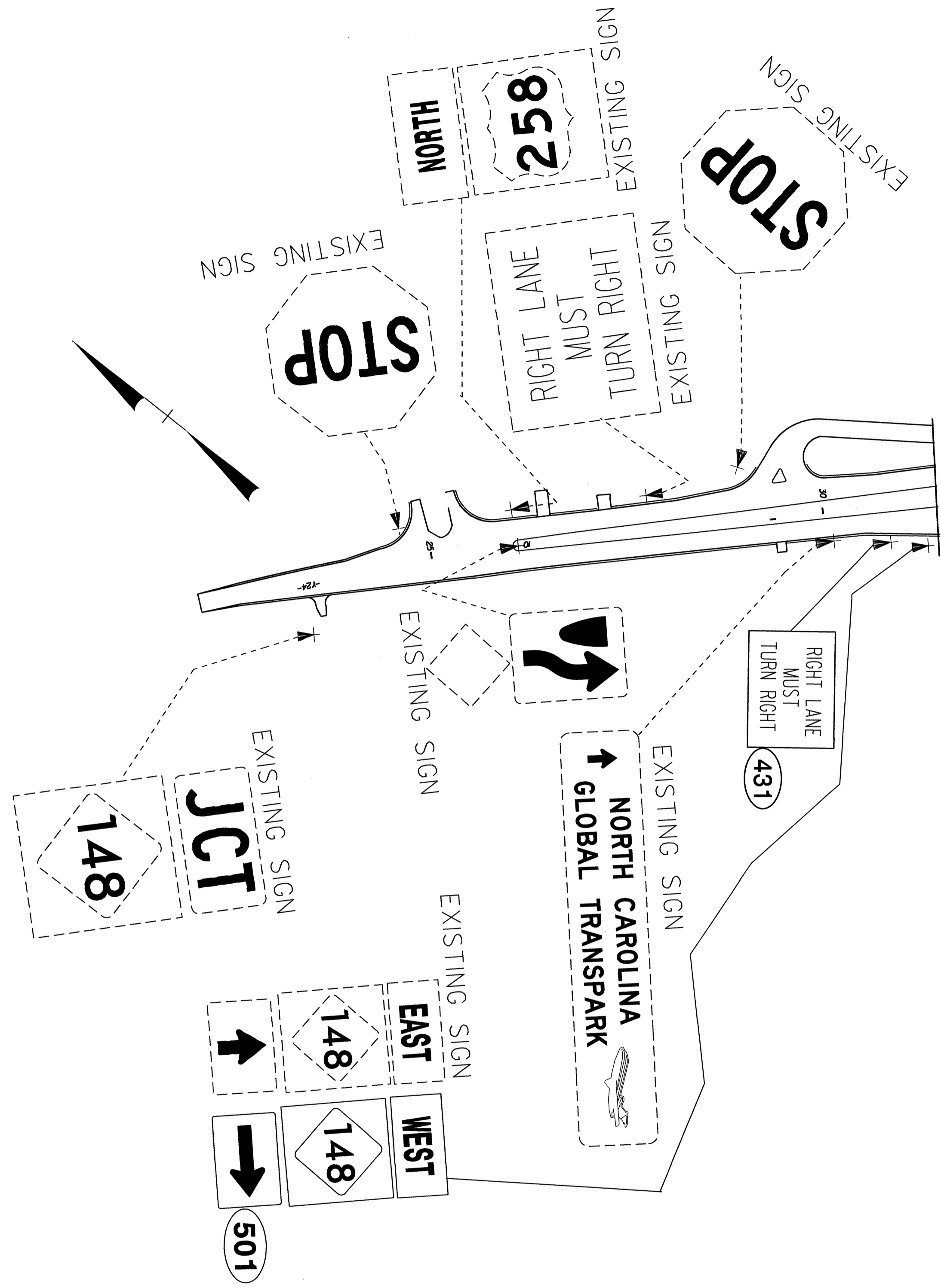

MATCH LINE
STA. -Y24 - 31+45
SEE SHEET SIGN-14

MATCH LINE
STA. -Y24 - 47+59
SEE SHEET SIGN-14

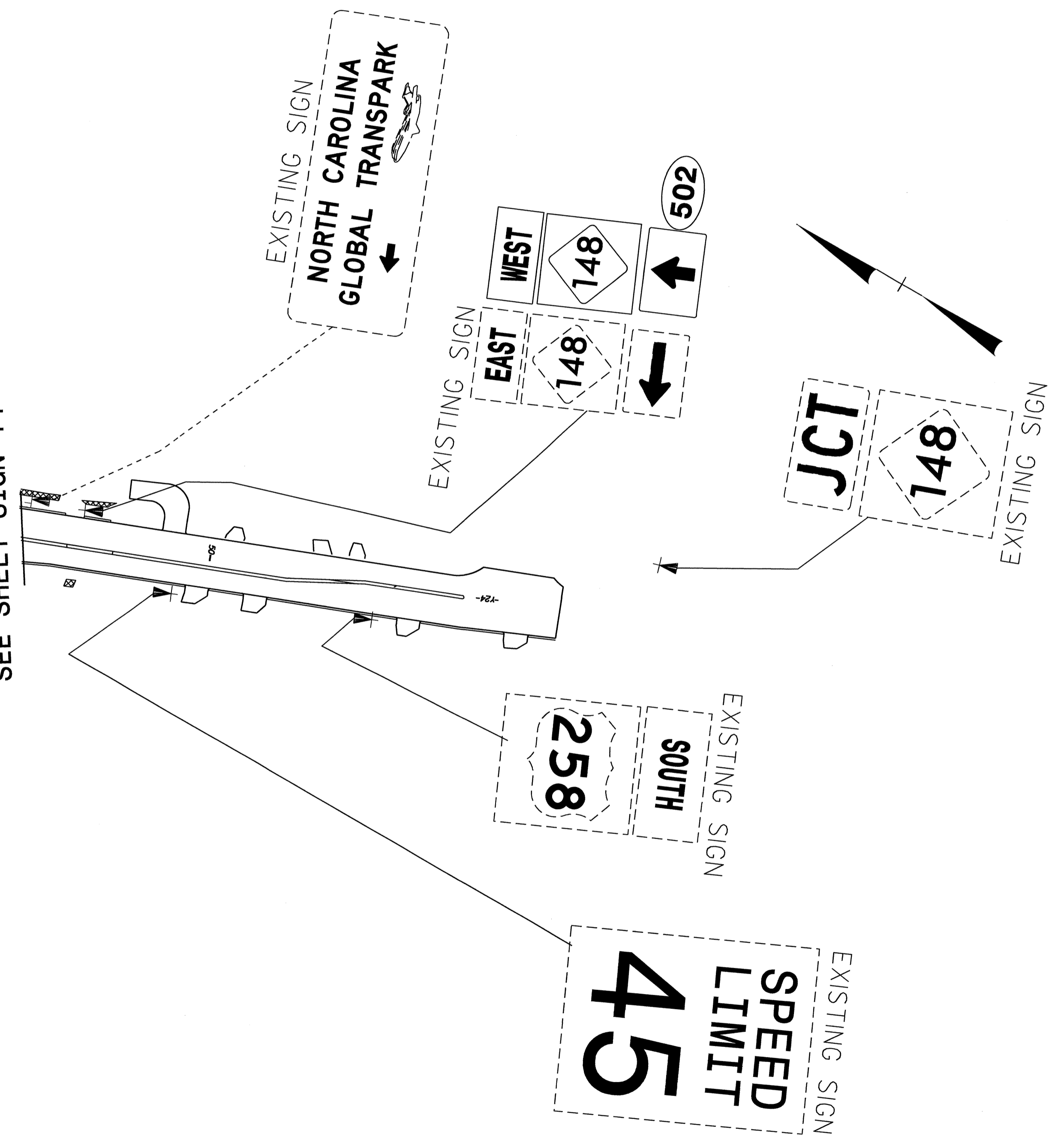

PROPOSED SIGNS
-L- STA. 196+00 TO STA 226+00

TIP NO. R-2719AA	SHEET NO. SIGN-37
APPROVED: <i>[Signature]</i>	
DATE: 2/21/12	
SEAL	

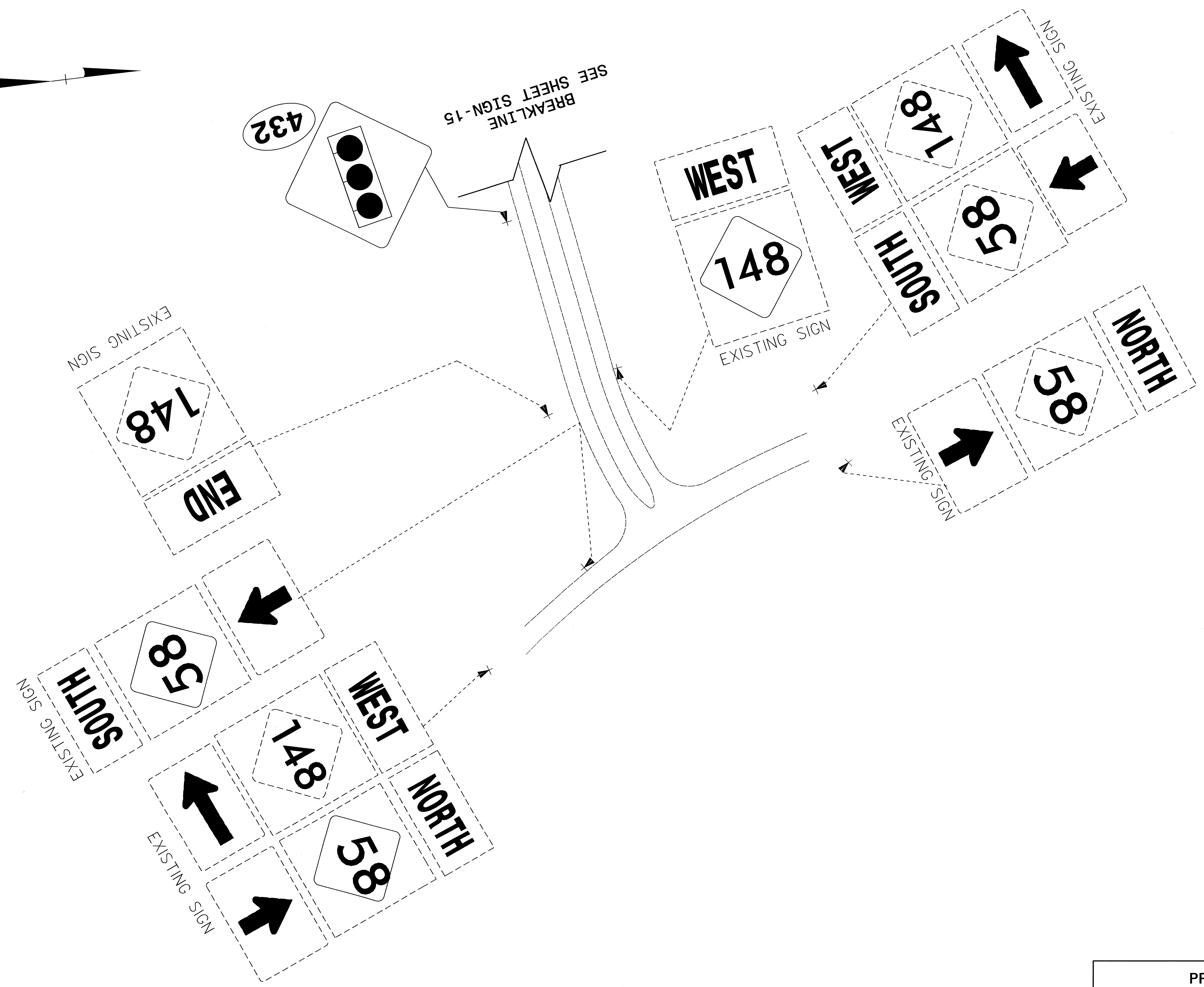
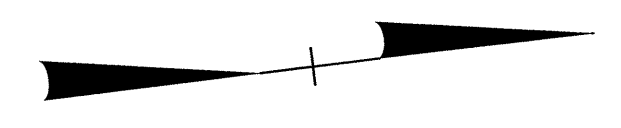

PROPOSED SIGNS
-L- STA. 196+00 TO STA 226+00