

T.I.P.: I-3819A

PROJECT: 34192.1.2

**STATE OF NORTH CAROLINA
 DEPARTMENT OF TRANSPORTATION**

**PAVEMENT MARKING PLAN
 IREDELL COUNTY**

**LOCATION: I-40I-77 INTERCHANGE INCLUDING I-40 FROM WEST OF
 SR 2003 (Radio Rd.) TO WEST OF SR 2158 (Old Mocksville Rd.) &
 I-77 FROM SOUTH OF I-40 TO SOUTH OF SR 2171 (Jane Sower Rd.)**

<small>TIP NO.</small> I-3819A	<small>SHEET NO.</small> PMP-1
<small>APPROVED:</small>	
<small>DATE:</small> 11-21-11	
<small>SEAL</small>	

Part 3 of 3

ROADWAY STANDARD DRAWING

THE FOLLOWING ROADWAY STANDARDS AS APPEAR IN "ROADWAY STANDARD DRAWINGS" - PROJECT SERVICES UNIT - N.C. DEPARTMENT OF TRANSPORTATION - RALEIGH, N.C., DATED JANUARY 2012 ARE APPLICABLE TO THIS PROJECT AND BY REFERENCE HEREBY ARE CONSIDERED A PART OF THESE PLANS:

<u>STD. NO.</u>	<u>TITLE</u>
1205.01	PAVEMENT MARKINGS - LINE TYPES AND OFFSETS
1205.02	PAVEMENT MARKINGS - 2 LANE AND MULTILANE ROADWAYS
1205.03	PAVEMENT MARKINGS - INTERCHANGES
1205.04	PAVEMENT MARKINGS - INTERSECTIONS
1205.05	PAVEMENT MARKINGS - TURN LANES
1205.06	PAVEMENT MARKINGS - THRU LANE DROPS
1205.07	PAVEMENT MARKINGS - PEDESTRIAN CROSSINGS
1205.08	PAVEMENT MARKINGS - SYMBOL AND WORD MESSAGES
1205.09	PAVEMENT MARKINGS - PAINTED ISLANDS
1205.12	PAVEMENT MARKINGS - BRIDGES
1205.13	PAVEMENT MARKINGS - LANE REDUCTIONS
1250.01	PAVEMENT MARKER SPACING
1251.01	RAISED PAVEMENT MARKERS - TEMPORARY AND PERMANENT
1253.01	SNOWPLOWABLE RAISED PAVEMENT MARKERS
1261.01	GUARDRAIL AND BARRIER DELINEATOR SPACING
1261.02	GUARDRAIL AND BARRIER DELINEATOR TYPES
1262.01	GUARDRAIL END DELINEATION
1264.02	OBJECT MARKERS - INSTALLATIONS
1267.01	FLEXIBLE DELINEATOR INSTALLATION
1267.02	FLEXIBLE DELINEATOR SPACING
1267.03	FLEXIBLE DELINEATOR - INTERCHANGES

GENERAL NOTES

THE FOLLOWING GENERAL NOTES APPLY AT ALL TIMES FOR THE DURATION OF THE CONSTRUCTION PROJECT, EXCEPT WHEN OTHERWISE NOTED IN THE PLAN, OR DIRECTED BY THE ENGINEER.

- A) INSTALL PAVEMENT MARKINGS AND PAVEMENT MARKERS ON THE FINAL SURFACE AS FOLLOWS:

ROAD NAME	MARKING	MARKER
-L-(I-40)/-Y-(I-77) Loops and Bridge Decks	Polyurea w/Highly Reflective Elements	Snowplowable (Raised on Bridge Decks)
All -Y- lines and -Y- line Bridge Decks	Polyurea w/Standard Beads	Snowplowable (Raised on Bridge Decks)
- B) TIE PROPOSED PAVEMENT MARKING LINES TO EXISTING PAVEMENT MARKING LINES.
- C) REMOVE/REPLACE ANY CONFLICTING/DAMAGED PAVEMENT MARKINGS AND MARKERS.
- D) PASSING ZONES WILL BE DETERMINED IN THE FIELD AND MUST BE APPROVED BY THE ENGINEER.
- E) STOPBAR LOCATION AT NON-SIGNALIZED INTERSECTIONS MAY BE ADJUSTED AS DIRECTED BY THE ENGINEER.
- F) USE HEATED-IN-PLACE THERMOPLASTIC OR COLD APPLIED PLASTIC PAVEMENT MARKING FOR SYMBOLS, CHARACTERS AND MARKING WHERE POLYUREA IS NOT PRACTICAL.
- G) MARKERS ARE TO BE SPACED ACCORDING TO THE ROADWAY STANDARD DRAWINGS.
- H) REMOVE ALL RESIDUE AND SURFACE LAITANCE BY ACCEPTABLE METHODS ON ALL CONCRETE SURFACES PRIOR TO PLACING POLYUREA PAVEMENT MARKING MATERIAL.

PLAN PREPARED BY: N.C.D.O.T. SIGNING AND DELINEATION UNIT

A. I. ALQUDWAH PE	SIGNING & DELINEATION REGIONAL ENGINEER
J. G. MARTINEZ	SIGNING & DELINEATION PROJECT DESIGN ENGINEER

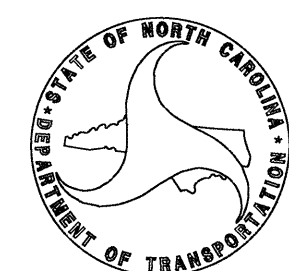

INDEX

<u>SHEET NO.</u>	<u>DESCRIPTION</u>
PMP-1 AND PMP-2	PAVEMENT MARKING PLAN TITLE AND SCHEDULE SHEET
PMP-2A	CROSSWALK & STOP BAR DETAIL
PMP 3-21	PAVEMENT MARKING DETAIL

TIP NO.	SHEET NO.
I-3819A	PMP-2
APPROVED: <i>[Signature]</i>	
DATE: 11-21-11	
SEAL	



PAVEMENT MARKING SCHEDULE

- THERMOPLASTIC (8", 90 MILS)
- TO WHITE DIAGONAL
TP YELLOW DIAGONAL
- THERMOPLASTIC (8", 120 MILS)
- TQ WHITE CROSSWALK LINE
- THERMOPLASTIC (24", 120 MILS)
- T2 WHITE STOPBAR
T3 WHITE CROSSWALK LINE
- THERMOPLASTIC PAVEMENT MARKING CHARACTER (120 MILS)
- UI ALPHANUMERIC CHAR.
- THERMOPLASTIC PAVEMENT MARKING SYMBOLS (90 MILS)
- UA LEFT TURN ARROW
UB RIGHT TURN ARROW
UC STRAIGHT ARROW
UD COMBO. STRAIGHT/LEFT
UE COMBO. STRAIGHT/RIGHT
UN 24" YIELD LINE TRIANGLE
UP MERGE ARROW
- POLYUREA (4") STANDARD GLASS BEADS
- V8 2 FT. - 6 FT./SP WHITE MINISKIP
VA WHITE EDGELINE
VB YELLOW EDGELINE
VC 10 FT. WHITE SKIP
VD 2 FT. - 9 FT./SP WHITE MINISKIP
VE WHITE SOLID LANE LINE
VI YELLOW DOUBLE CENTER
- POLYUREA (6") HIGHLY REFLECTIVE ELEMENTS
- V6 WHITE EDGELINES
V7 YELLOW EDGELINE
VJ 10 FT. WHITE SKIP
VK 2 FT. - 9 FT./SP WHITE MINISKIP
VL WHITE SOLID LANE LINE
- POLYUREA (12") HIGHLY REFLECTIVE ELEMENTS
- VS WHITE GORELINE
- PERMANENT RAISED PAVEMENT MARKERS
- MA - YELLOW & YELLOW -Y1- BRIDGE DOUBLE YELLOW, (@ 80 FT SPACING)
MB - CRYSTAL & RED -Y4- BRIDGE LANE LINES, (@ 20 FT SPACING)
MB - CRYSTAL & RED -Y4-BRIDGE SKIPS LINES, (@ 80 FT SPACING)
- SNOWPLOWABLE RAISED PAVEMENT MARKERS
- ME - YELLOW & YELLOW DOUBLE YELLOW, (@ 80 FT SPACING)
MF - CRYSTAL & RED GORE LINES, (@ 20 FT SPACING)
MF - CRYSTAL & RED LANE LINES, (@ 20 FT SPACING)
MF - CRYSTAL & RED -L- LINE SKIPS, (@ 80 FT SPACING)
- 7' U-CHANNEL POST
OBJECT MARKER (END OF ROAD)
- CURING COMPOUND REMOVAL (PAVEMENT MARKING LINES)
CURING COMPOUND REMOVAL (PAVEMENT MARKING SYMBOLS AND CHARACTERS)
*NO CURING COMPOUND REMOVAL ON BRIDGE DECKS

PAVEMENT MARKING SCHEDULE

14-NOV-2011 15:59
 I:\NIP\Projects\13819A\Tce\Tic\Signing\CADD\PMPI-3819A_PMP_L.dgn
 gmdr:thez AT 11/21/11

TIP NO. I-3819A	SHEET NO. PMP-2A
APPROVED: <i>[Signature]</i>	
DATE: 11-21-11	
SEAL	
	

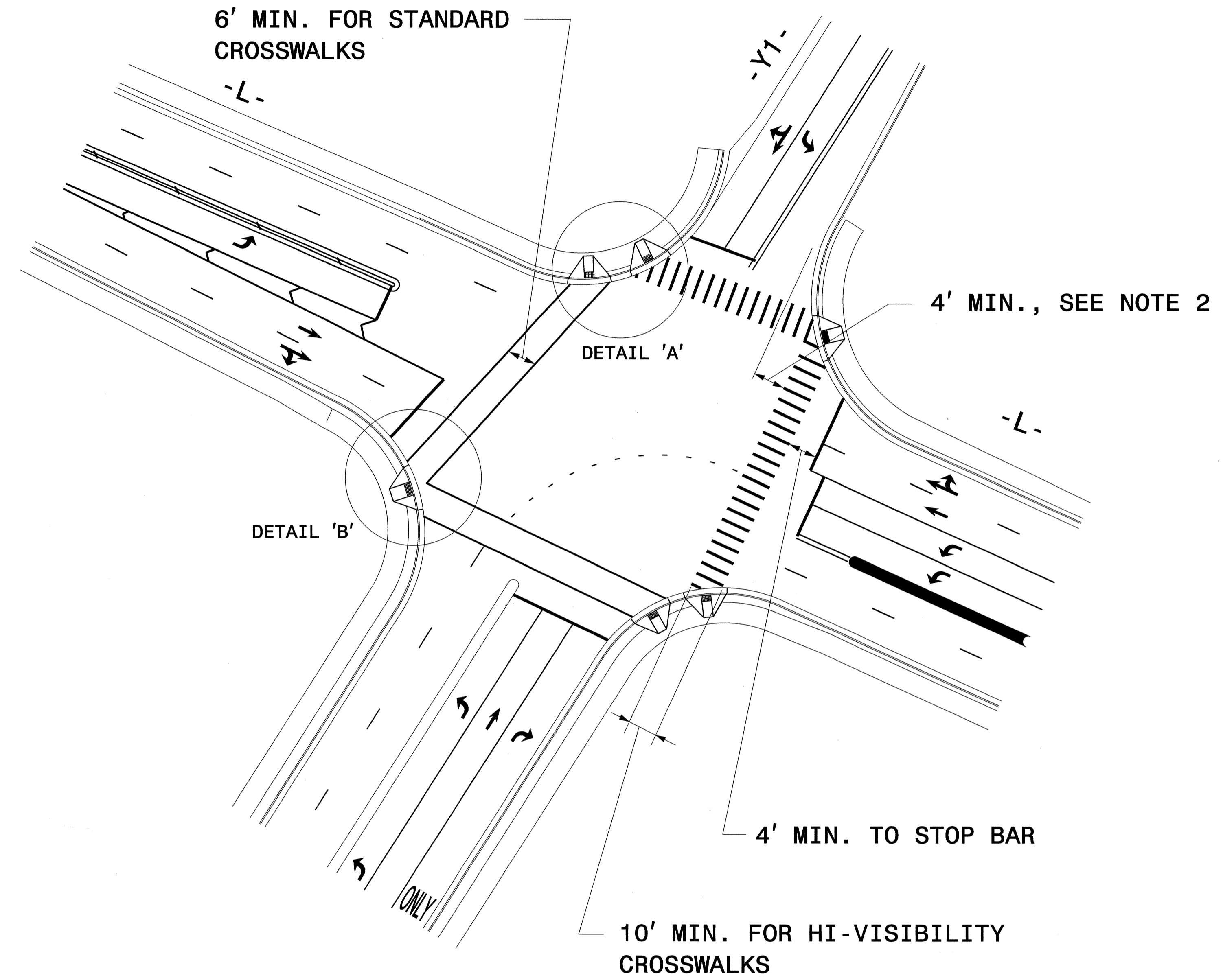

GUIDANCE DETAIL FOR STANDARD AND HI-VISIBILITY CROSSWALKS AT SIGNALIZED OR STOP SIGN CONTROLLED INTERSECTIONS

- NOTES:
1. USE DETAILS ABOVE AND THE FOLLOWING NOTES FOR GUIDANCE IN PLACING CROSSWALKS AND STOP BARS NOT STATIONED ON THE DETAIL SHEETS OR WHEN FIELD ADJUSTMENTS REQUIRED MOVING STATIONED MARKINGS AS DIRECTED BY THE ENGINEER. REFER TO NCDOT ROADWAY STANDARD DRAWINGS, MUTCD AND ADA STANDARDS FOR ADDITIONAL GUIDANCE.
 2. SET BACK DISTANCE FROM INSIDE CROSSWALK MARKING TO NEAREST EDGE OF TRAVEL IS 4' MIN.
 3. BEYOND THE CURB FACE, A CLEAR SPACE OF 4' X 4' MINIMUM SHALL BE PROVIDED WITHIN THE WIDTH OF THE CROSSWALK.
 4. SINGLE DIAGONAL CURB RAMPS WITH FLARED SIDES SHALL HAVE A SEGMENT OF CURB 2 FEET LONG MINIMUM LOCATED ON EACH SIDE OF THE CURB RAMP AND WITHIN THE MARKED CROSSING, SEE DETAIL 'B'.
 5. CURB RAMPS SHALL BE CONSTRUCTED IN ACCORDANCE TO THE LATEST NCDOT ROADWAY STANDARD DRAWINGS.

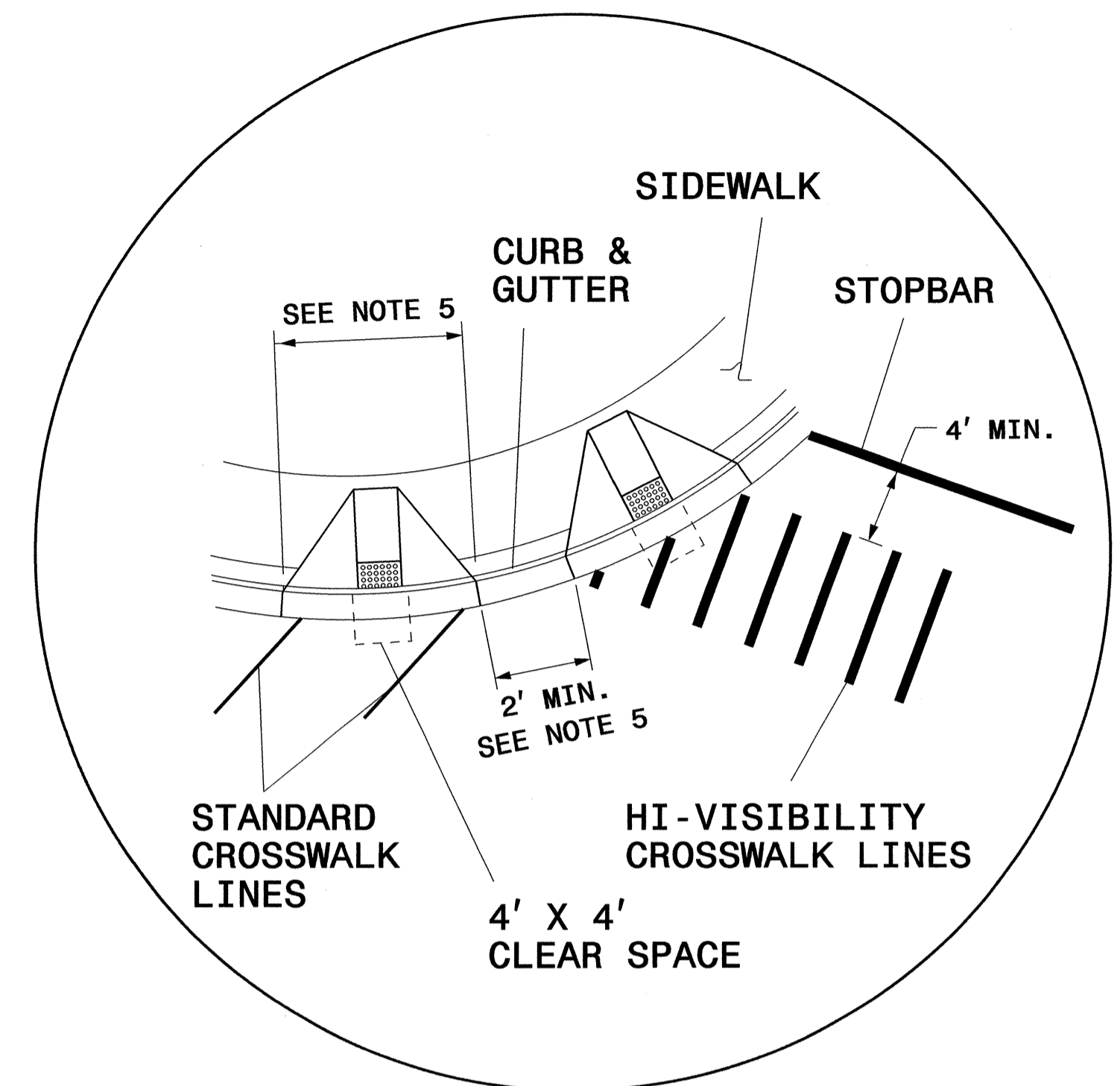

DETAIL 'A'- DUAL CURB RAMPS

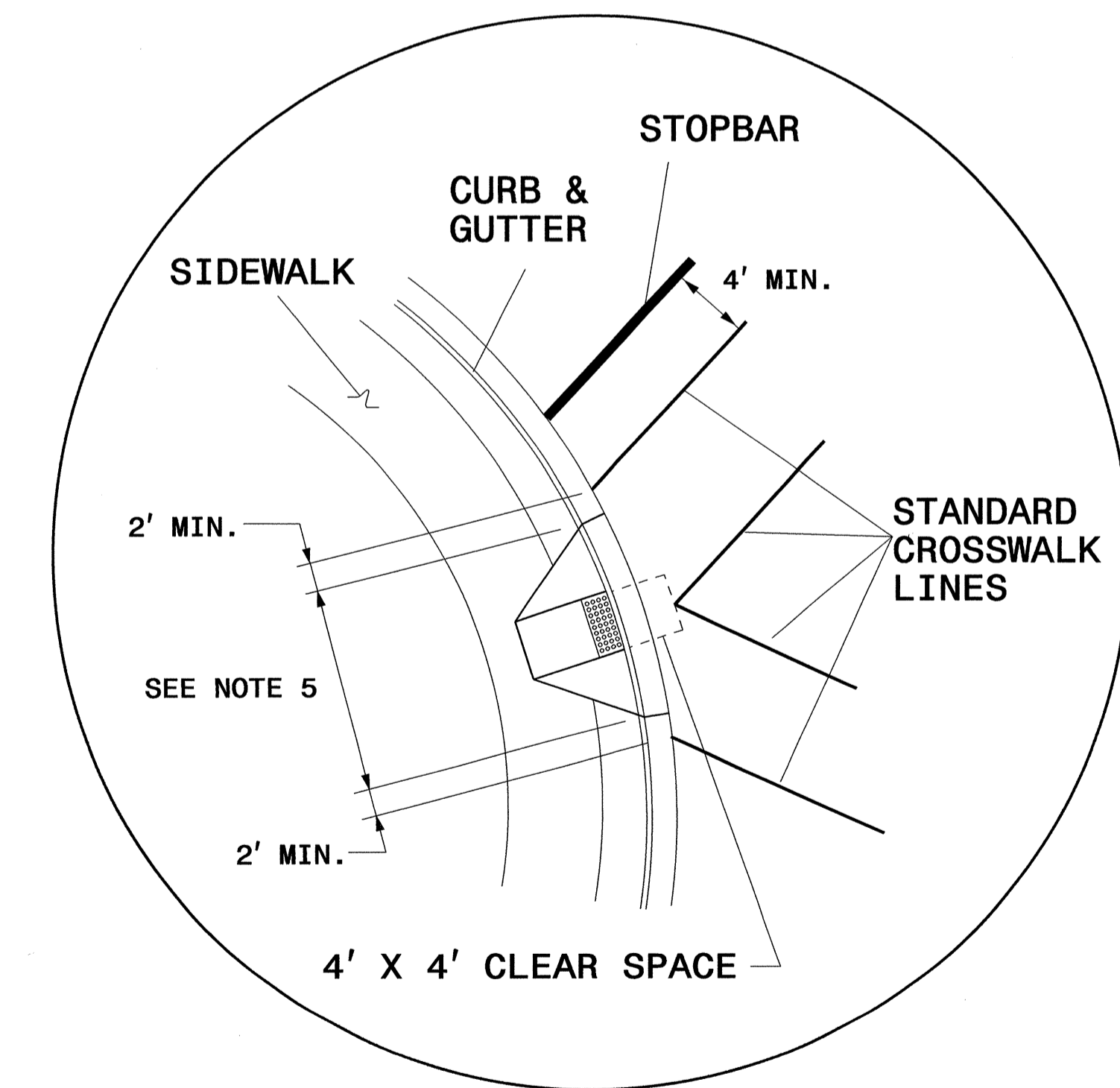

DETAIL 'B'- SINGLE DIAGONAL CURB RAMP

CROSSWALK AND STOP BAR PAVEMENT MARKING DETAIL

14-NOV-2011 16:01
 P:\TIP\Projects\I3819A\Traf\Signing\CADD\PM\I-3819A_PMP_2A_Curb Ramp and Crosswalk Guidance 8-23-11.dgn
 Jgmarfinez AT TE247795

TIP NO. I-3819A	SHEET NO. PMP-3
APPROVED: <i>[Signature]</i>	
DATE: 11-21-11	
SEAL	

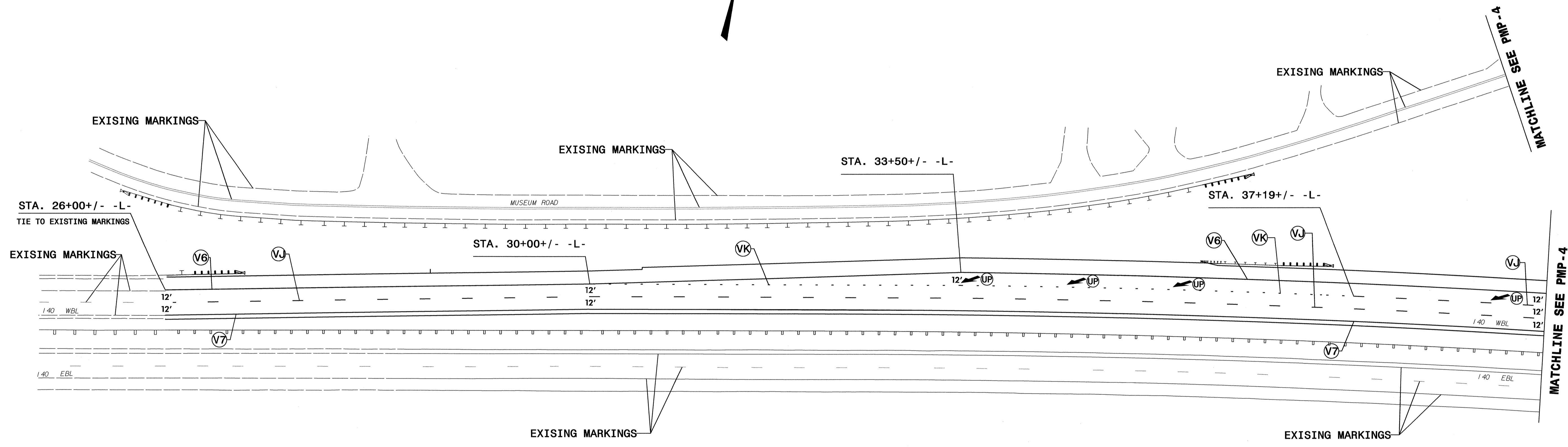

**I 40
PAVEMENT MARKING DETAIL**

I:\N\2011\603
 P:\1\3819A\Traffic\Signing\CADD\PMPI-3819A_PMP_03.dgn
 jgmartinez At 11/21/11

TIP NO. I-3819A	SHEET NO. PMP-4
APPROVED: <i>[Signature]</i>	
DATE: 11-21-11	
SEAL	

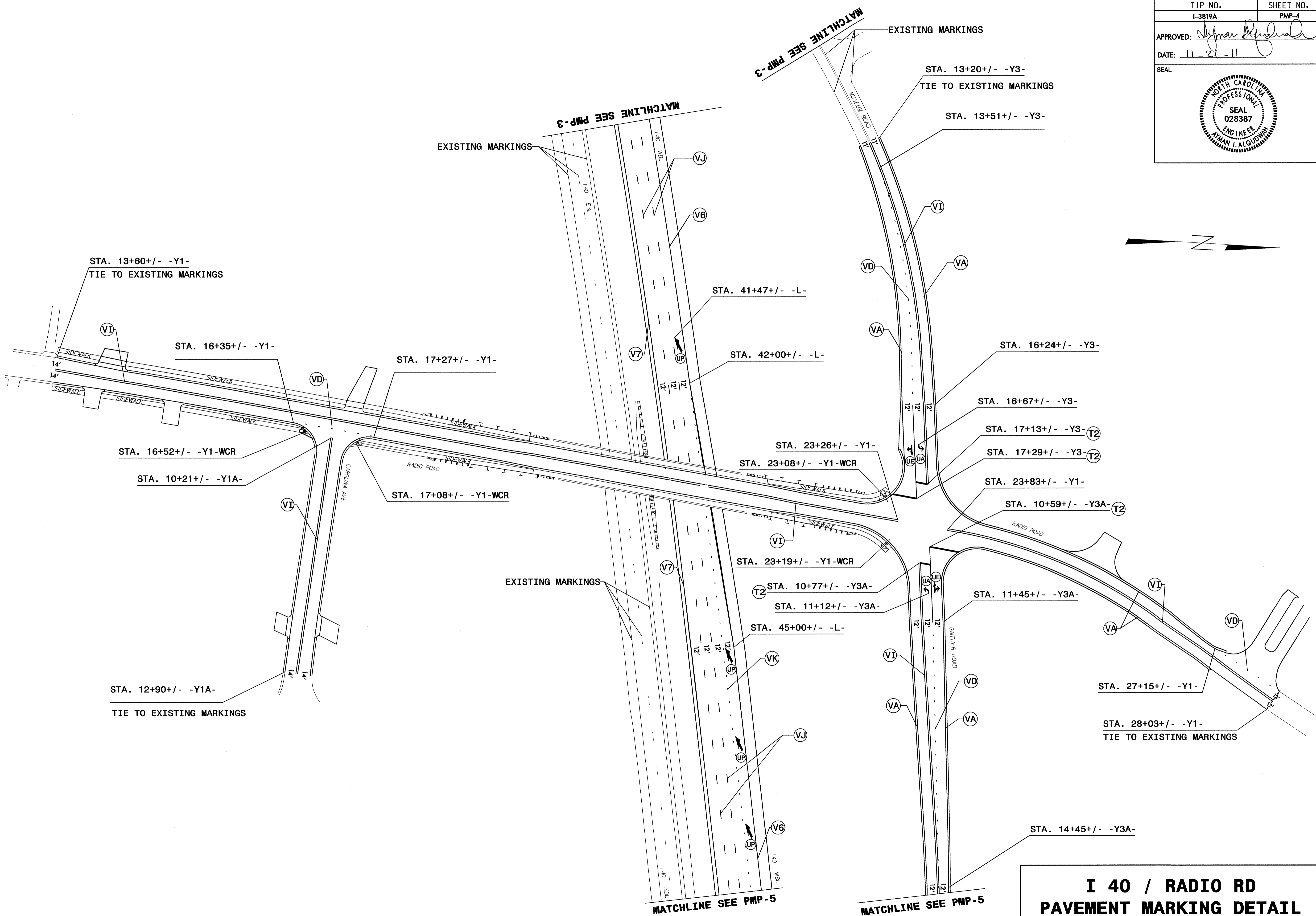
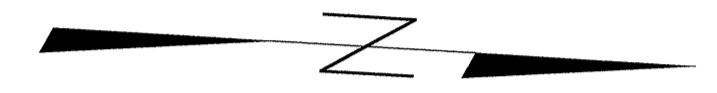

**I 40 / RADIO RD
PAVEMENT MARKING DETAIL**

I:\Projects\2011\11-16-11\I-3819A\Traffic\Signing\CADD\PMP-I-3819A_PMP_04.dgn
 P:\Projects\2011\11-16-11\I-3819A\Traffic\Signing\CADD\PMP-I-3819A_PMP_04.dgn
 jgmer-tne-z At 11/21/11

TIP NO. I-3819A	SHEET NO. PMP-5
APPROVED: <i>[Signature]</i>	
DATE: 11-21-11	
SEAL	

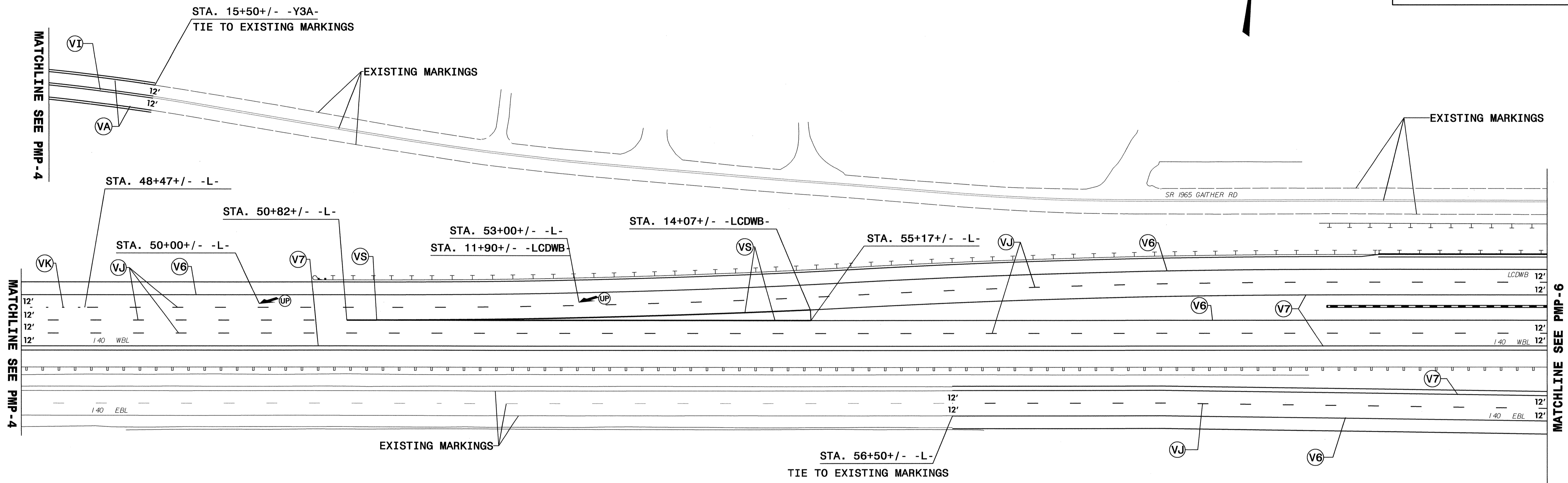

**I 40
PAVEMENT MARKING DETAIL**

I:\N\2011\605
 P:\Projects\I-3819A\Traffic\Signing\CADD\MP\I-3819A_PMP_05.dgn
 U:\gimart\at 11/24/11

TIP NO. I-3819A	SHEET NO. PMP-6
APPROVED: <i>[Signature]</i>	
DATE: 11-21-11	
SEAL	

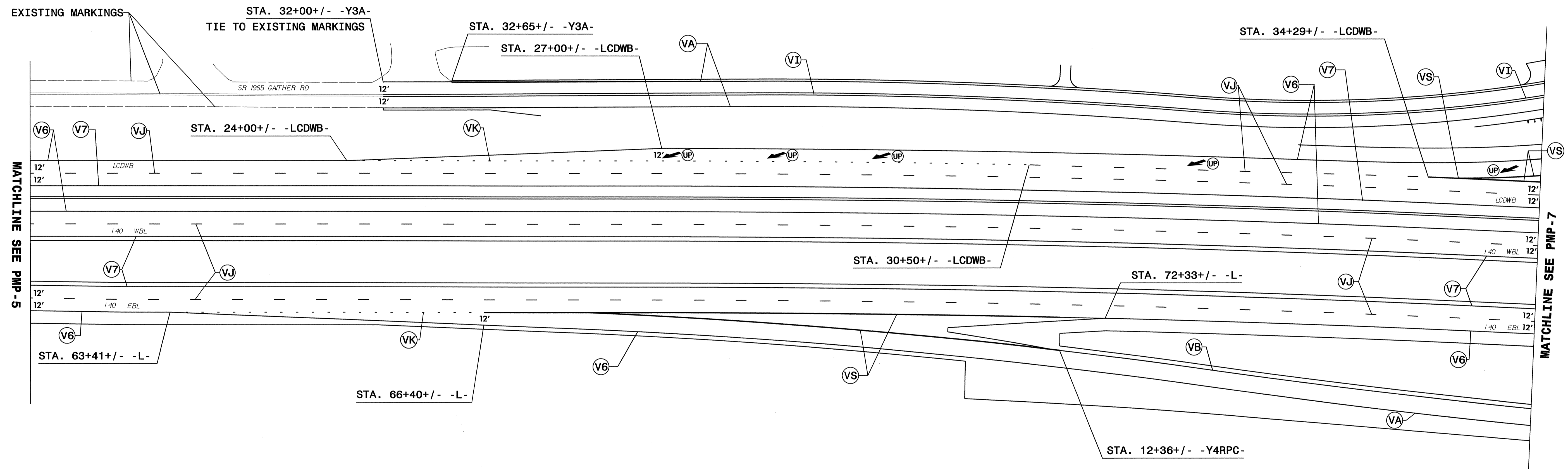
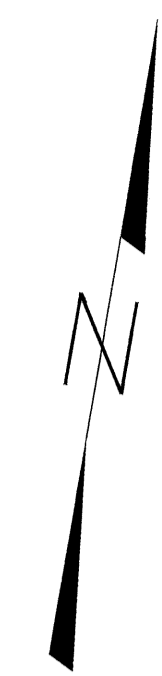

I:\NOV-2011\6508
 P:\10\pmp\pmp-6\1-3819A\Traf\Signing\CADD\pmp-1-3819A_PMP_06.dgn
 11/21/11 10:24:11 AM
 jgmar-tinez

**I 40
PAVEMENT MARKING DETAIL**

TIP NO. I-3819A	SHEET NO. PMP-7
APPROVED: <i>[Signature]</i>	
DATE: 11-21-11	
SEAL	

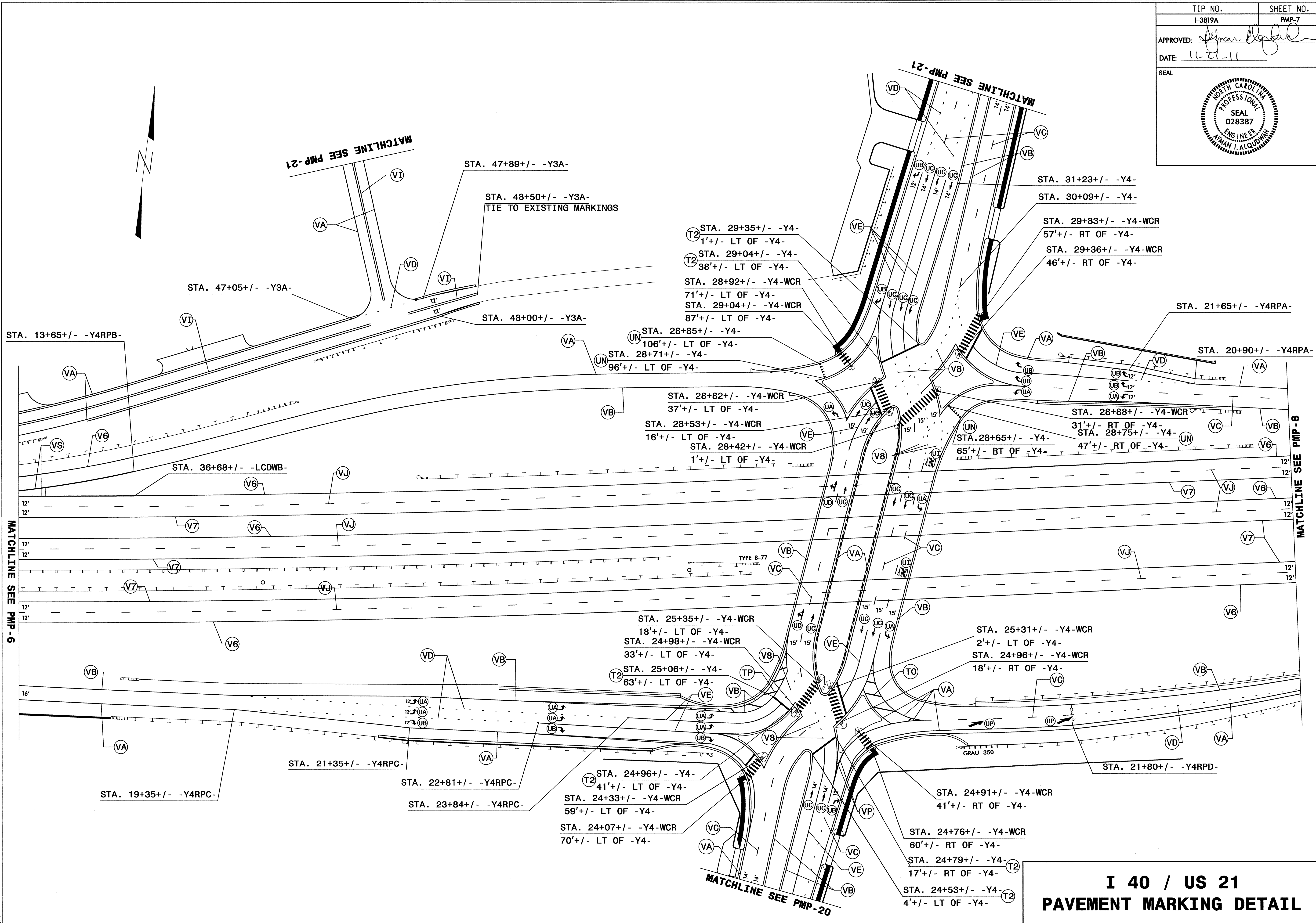

**I 40 / US 21
PAVEMENT MARKING DETAIL**

I:\Projects\2011\608\I-3819A\Teffic\Signing\CADD\I-3819A_PMP-07.dgn
 Date: 11/21/11
 User: jgmartinez

TIP NO.	SHEET NO.
I-3819A	PMP-8
APPROVED: <i>[Signature]</i>	
DATE: 11-21-11	
SEAL	

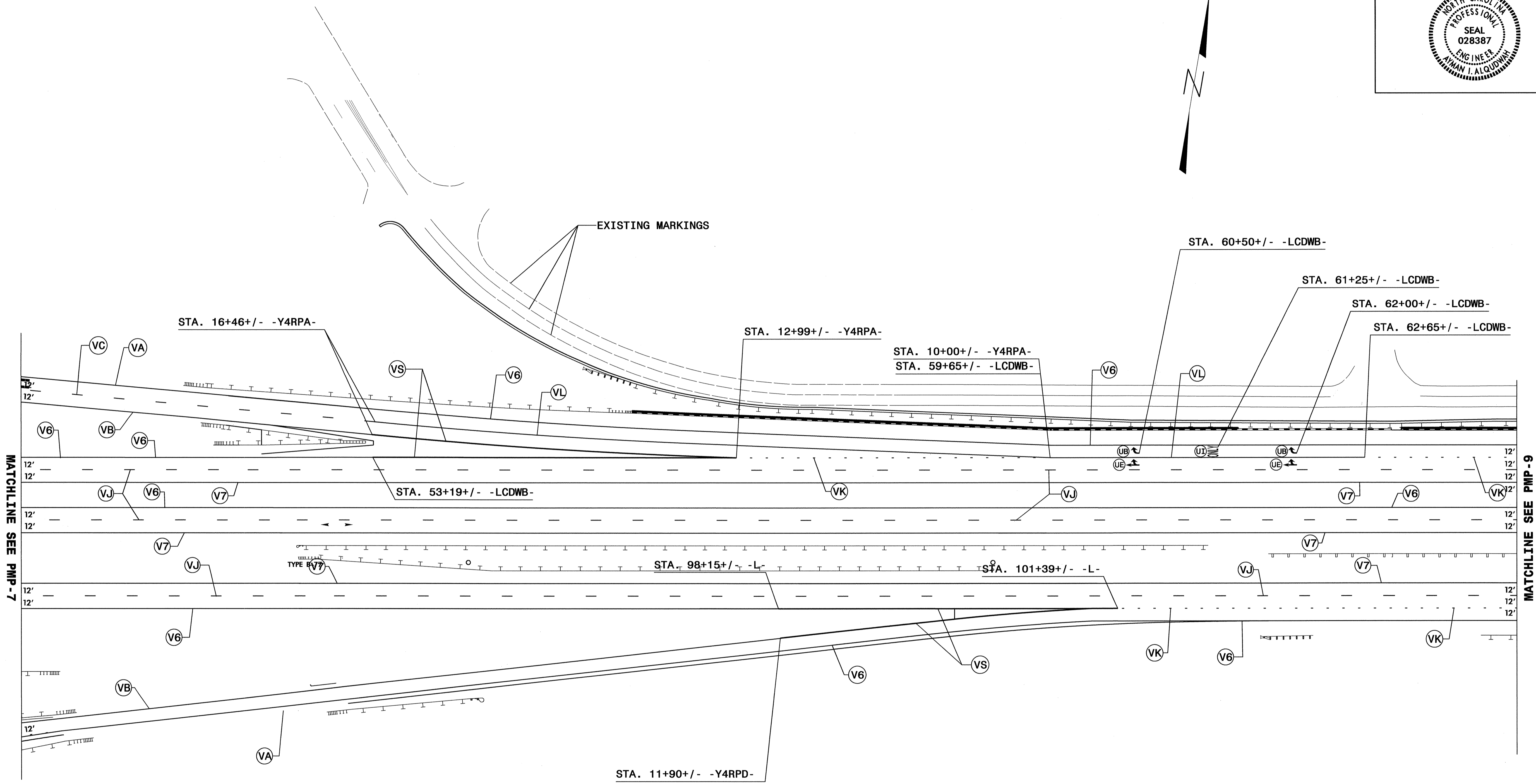
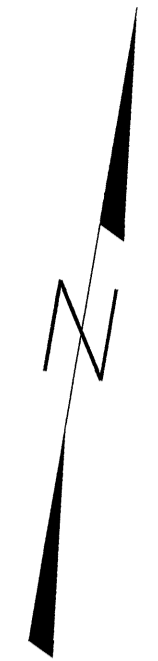

MATCHLINE SEE PMP-7

MATCHLINE SEE PMP-9

I:\NOV-2011\6:09 PM\I-3819A\Traffic\CADD\PMP-I-3819A_PMP_08.dgn
 I-3819A Traffic - E247795

**I 40
PAVEMENT MARKING DETAIL**

TIP NO. I-3819A	SHEET NO. PMP-9
APPROVED: <i>[Signature]</i>	
DATE: 3-26-12	
SEAL	

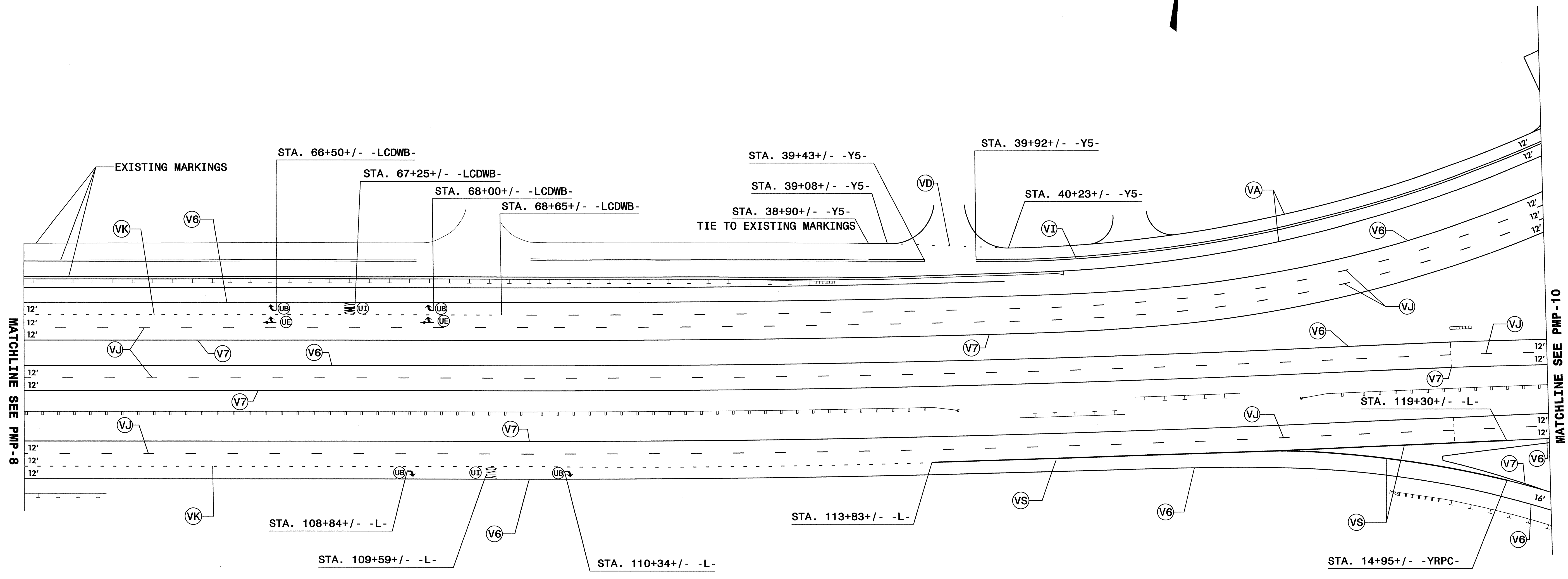
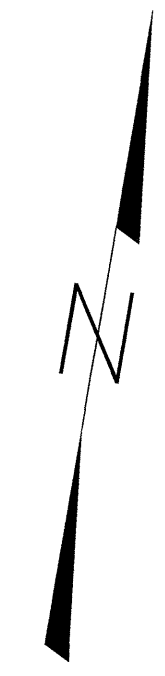

**I 40
PAVEMENT MARKING DETAIL**

26-MAR-2012 11:32 AM C:\Users\afre\Documents\CADD\PMPI-I-3819A_PMP-09.dgn
 I-3819A_PMP-09.dwg
 I-3819A_PMP-09.dwg
 I-3819A_PMP-09.dwg

TIP NO. I-3819A	SHEET NO. PMP-10
APPROVED: <i>[Signature]</i>	
DATE: 3-26-12	
SEAL	

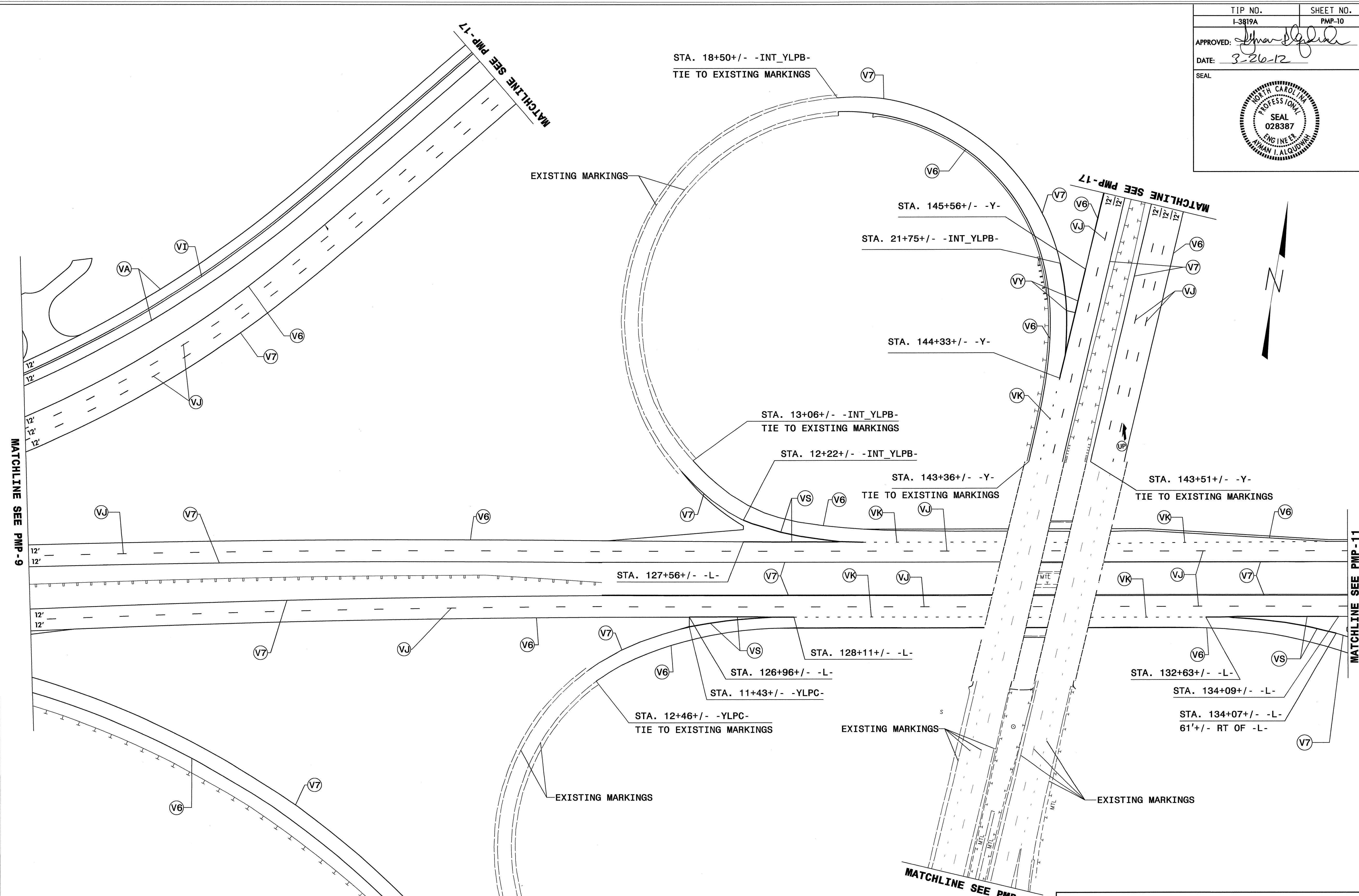
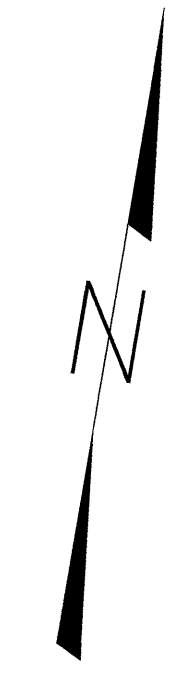

**I 40 / I 77
PAVEMENT MARKING DETAIL**

26 MAR-2012 11:33 I:\3819A\Traf\Signing\CADD\PMPT-I-3819A_PMP_10.dgn
 User: jmartinez
 Plot: 1127795

TIP NO. I-3819A	SHEET NO. PMP-11
APPROVED: <i>[Signature]</i>	
DATE: 3-26-12	
SEAL	

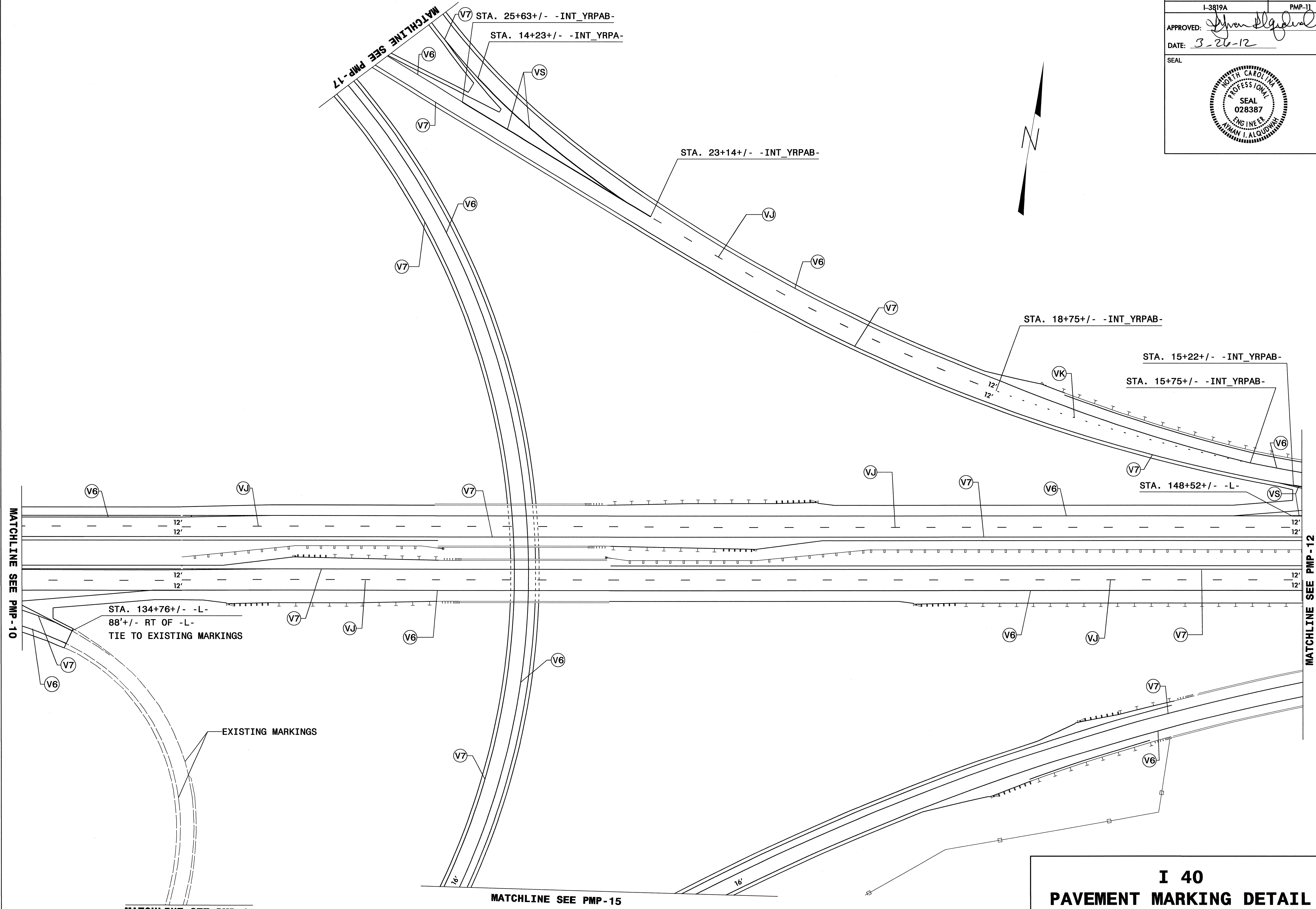
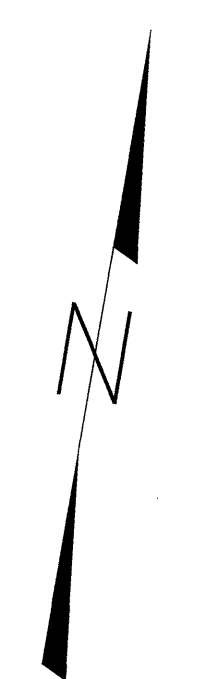

**I 40
PAVEMENT MARKING DETAIL**

26-MAR-2012 11:34
 P:\Projects\I-3819A\Teffie\Signing\CADD\PMPT-I-3819A_PMP-11.dgn
 jmarquez AI 11/27/12

TIP NO. I-3819A	SHEET NO. PMP-12
APPROVED: <i>[Signature]</i>	
DATE: 11-21-11	
SEAL	

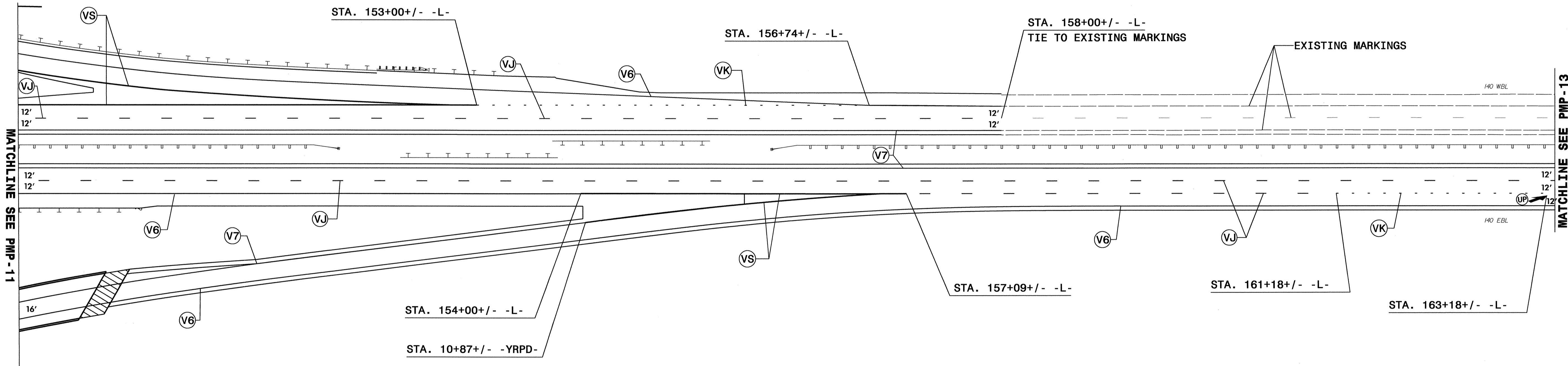
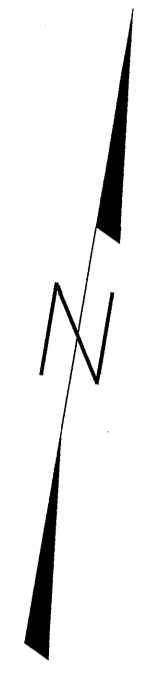

**I 40
PAVEMENT MARKING DETAIL**

I:\Projects\I-3819A\Teffric\Signing\CADD\PMPI-3819A_PMP-12.dgn
 11/21/11 10:16:11 AM
 A1 TE247795

TIP NO. I-3819A	SHEET NO. PMP-13
APPROVED: <i>[Signature]</i>	
DATE: 3-26-12	
SEAL	
	

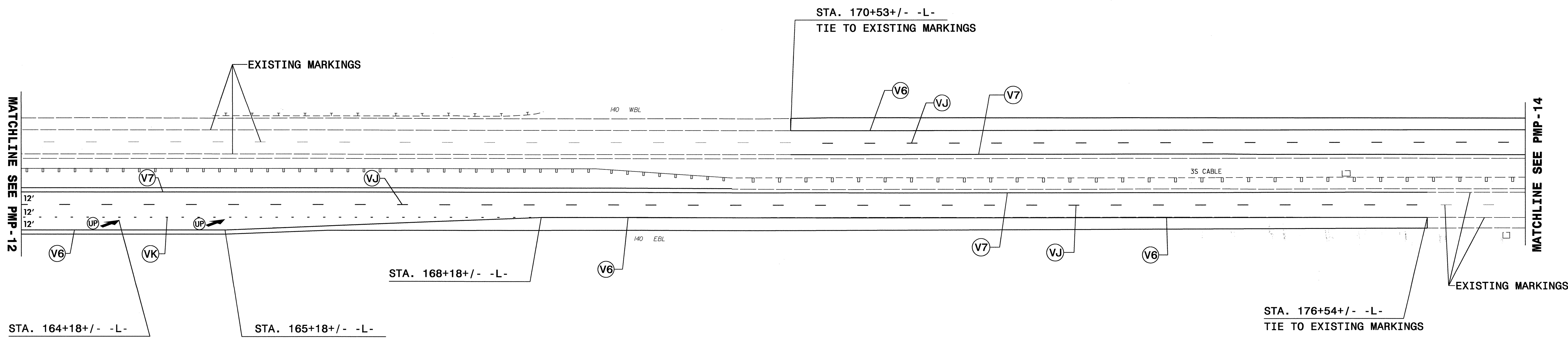

**I 40
PAVEMENT MARKING DETAIL**

25-MAR-2012 11:28 AM C:\Users\jamar-tinaz\Documents\13819A\Traffic\Signing\CADD\PMPT-I-3819A_PMP-13.dgn
 jamar-tinaz 11:27:45

TIP NO. I-3819A	SHEET NO. PMP-14
APPROVED: <i>[Signature]</i>	
DATE: 3-26-12	
SEAL	
	

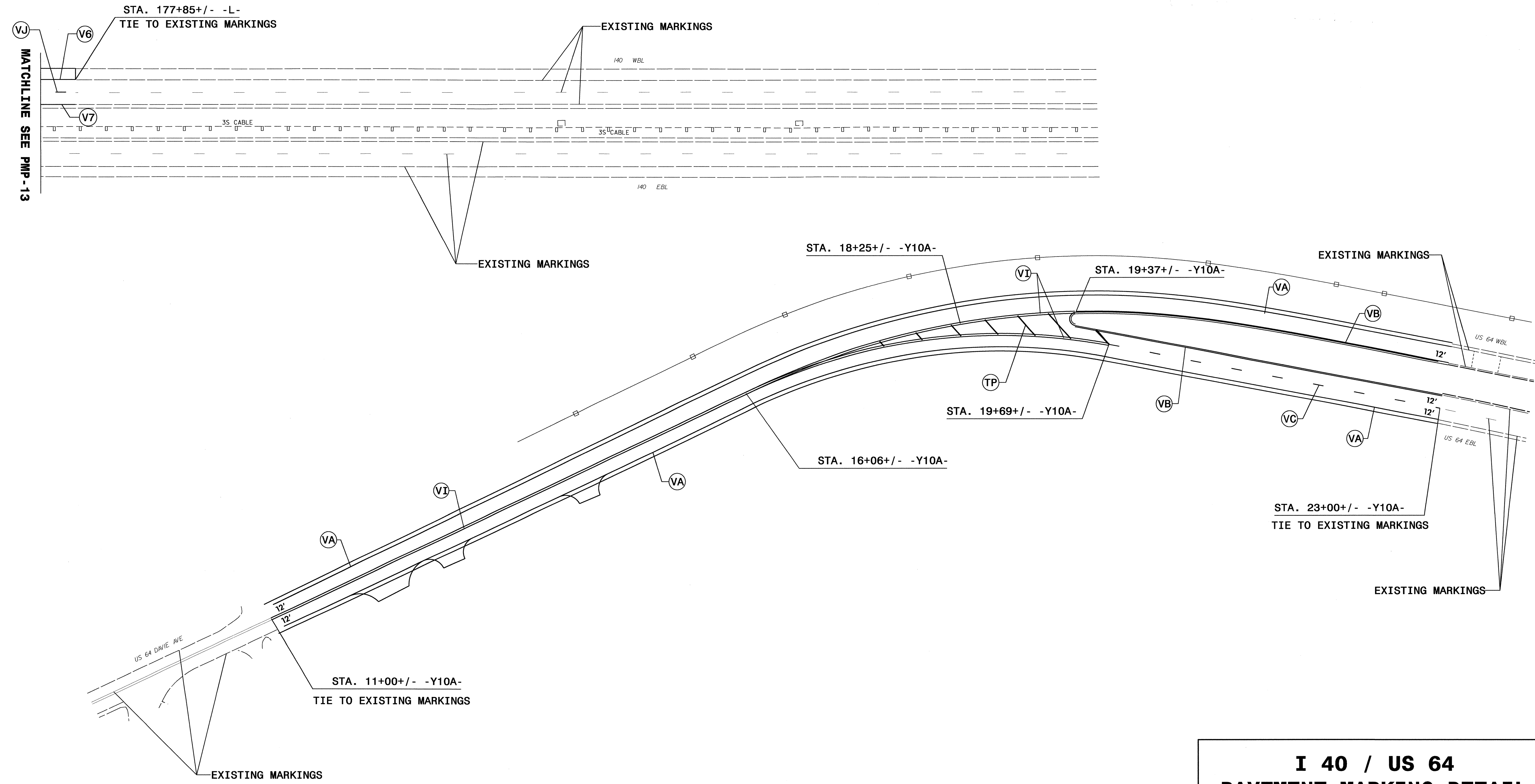
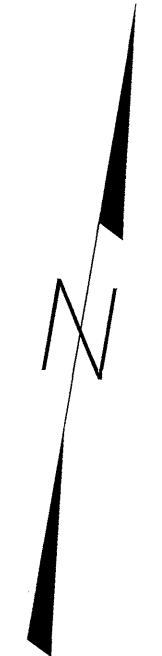

**I 40 / US 64
PAVEMENT MARKING DETAIL**

25 MAR 2012 11:31 AM I:\3819A\Traffic\Signing\CADD\PMPI-3819A_PMP-14.dgn
 jamar-tunez

TIP NO. I-3819A	SHEET NO. PMP-15
APPROVED: <i>[Signature]</i>	
DATE: 11-21-11	
SEAL	

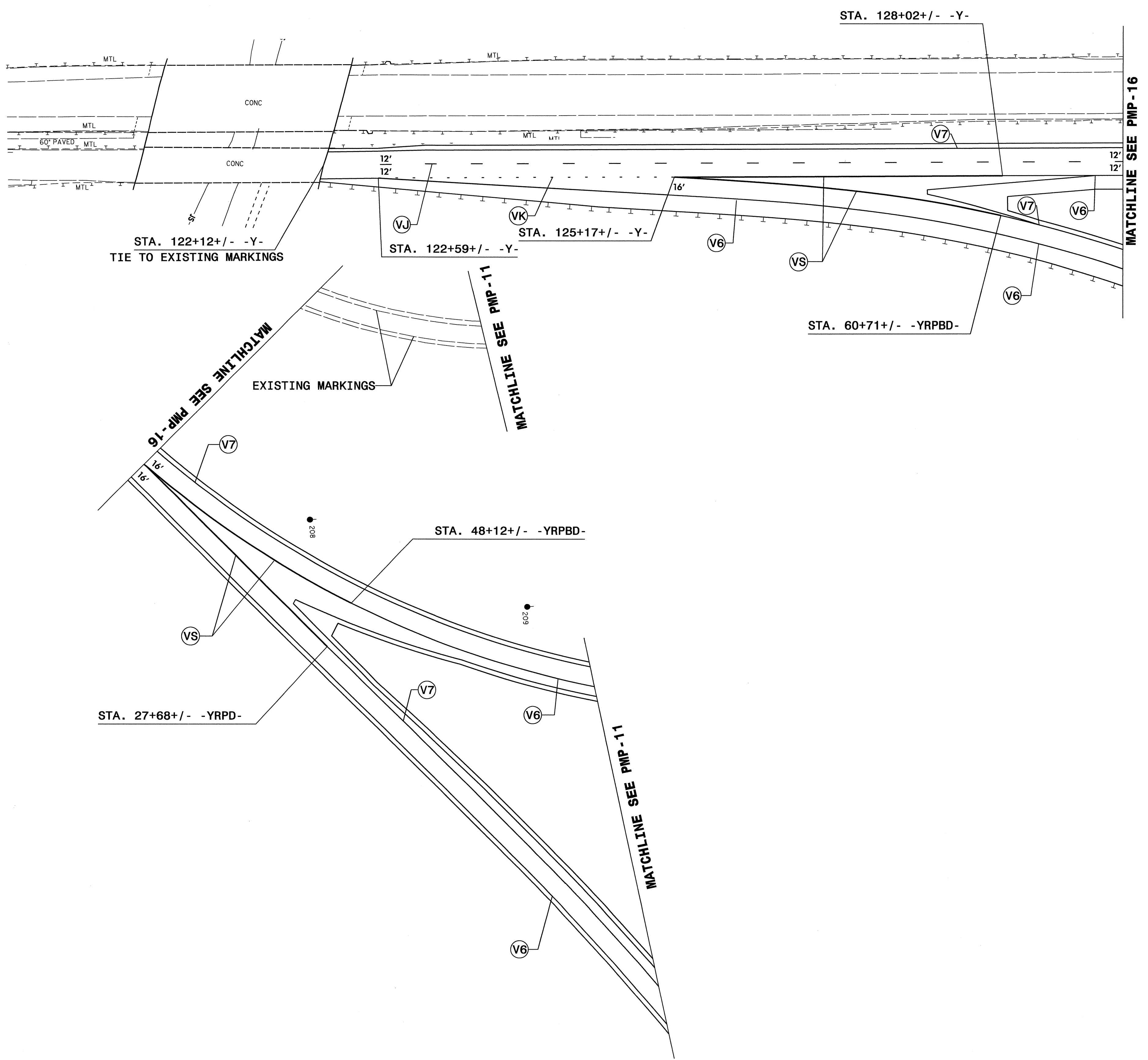
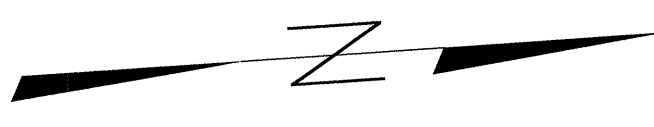

**I 77
PAVEMENT MARKING DETAIL**

I:\NOV\2011\615
 57\01\pmp\pmp-15\I-3819A\Teffric\Signing\CADD\pmp-15-3819A_PMP_15.dgn
 11/21/11 10:47:45 AM

TIP NO. I-3819A	SHEET NO. PMP-17
APPROVED: <i>[Signature]</i>	
DATE: 11-21-11	
SEAL	
	

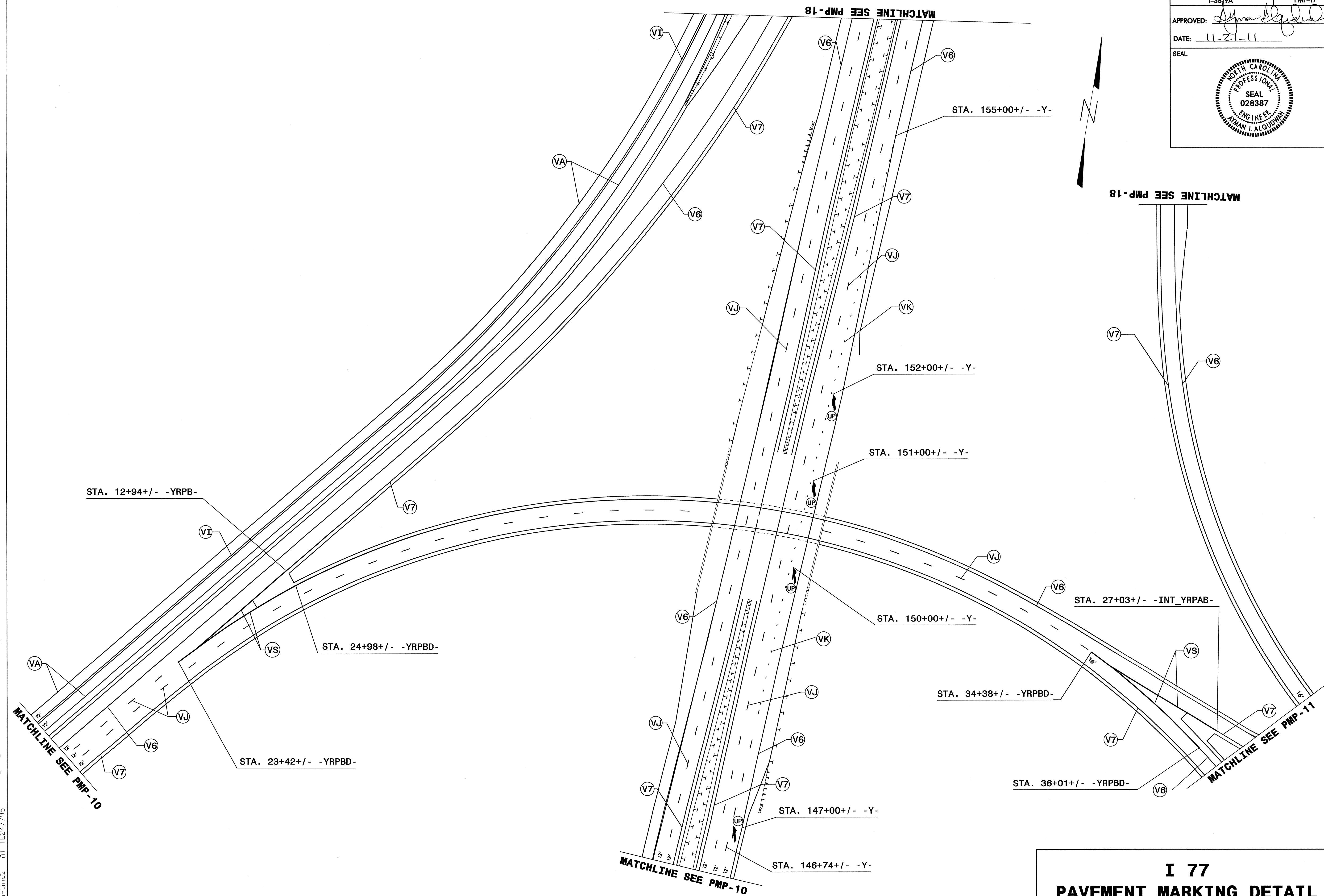

**I 77
PAVEMENT MARKING DETAIL**

I:\Projects\I-3819A\Traffic\Signing\CADD\PMPI-3819A_PMP-17.dgn
 11/21/11 10:44 AM
 User: jgmartinez

TIP NO. I-3819A	SHEET NO. PMP-18
APPROVED: <i>Ahmad Alquodw</i>	
DATE: 11-21-11	
SEAL	

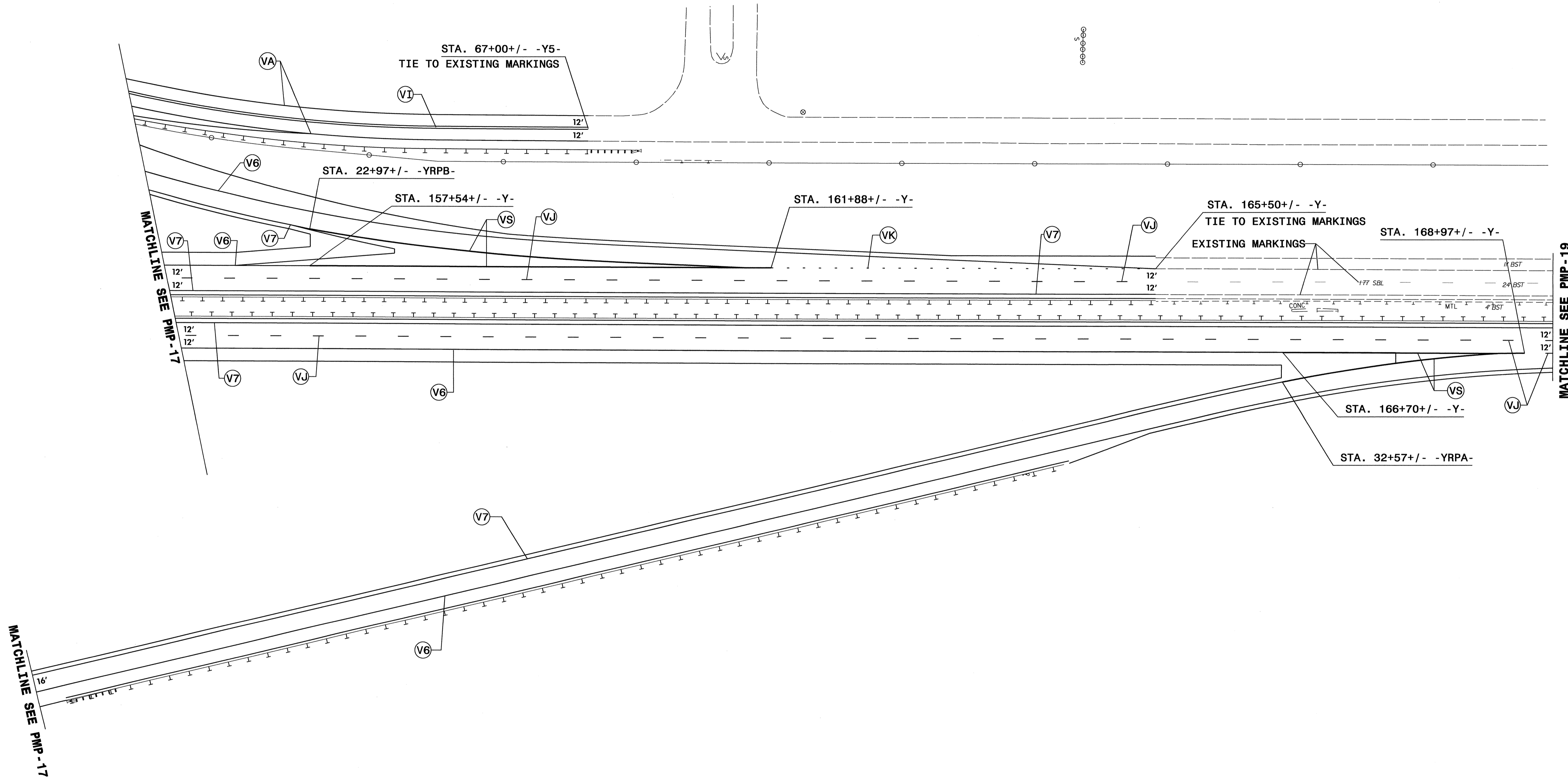
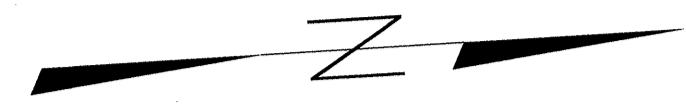

**I 77
PAVEMENT MARKING DETAIL**

14-NOV-2011 16:45
 P:\I-77\Projects\I-77\I-77\Signing\CADD\PMPI-3819A_PMP-18.dgn
 Jgambino

TIP NO. I-3819A	SHEET NO. PMP-20
APPROVED: <i>[Signature]</i>	
DATE: 11-21-11	
SEAL	

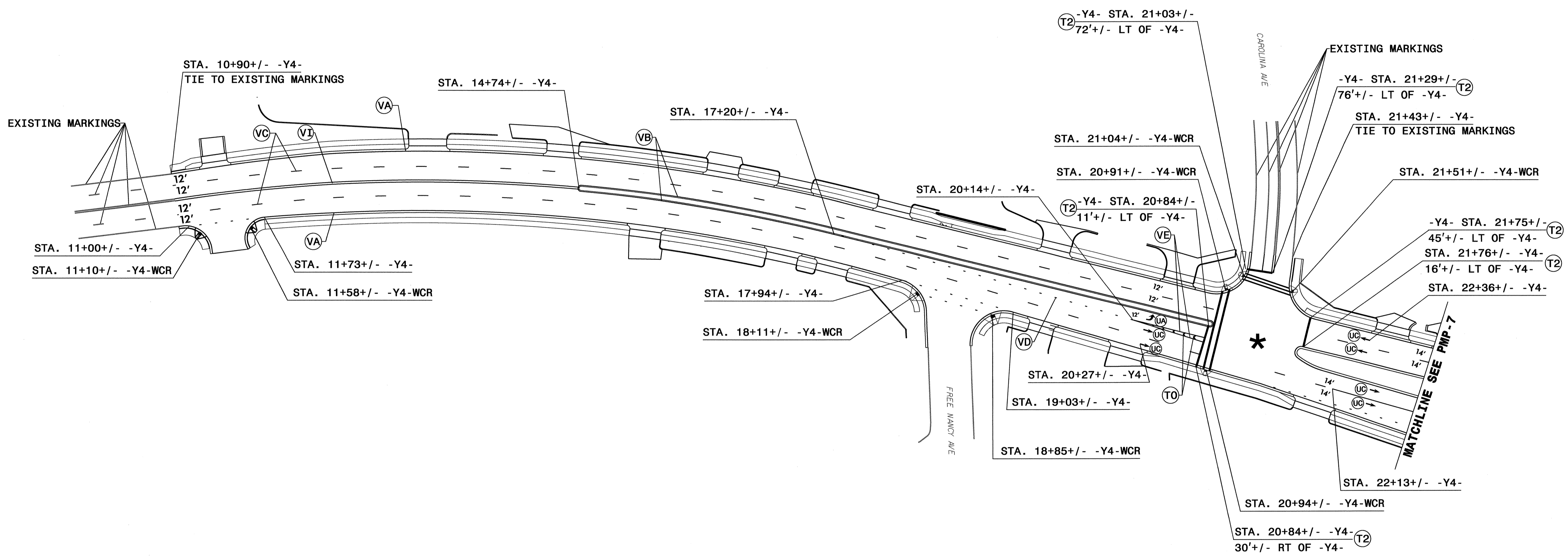

* SIGNALIZED

PAVEMENT MARKING DETAIL

I:\Projects\113819A\Traffic\Signing\CADD\PMP\I-3819A_PMP_20.dgn
 11/21/11 10:56:17 AM
 Aymen I. Alquodmani

TIP NO. I-3819A	SHEET NO. PMP-21
APPROVED: <i>[Signature]</i>	
DATE: 11-21-11	
SEAL	

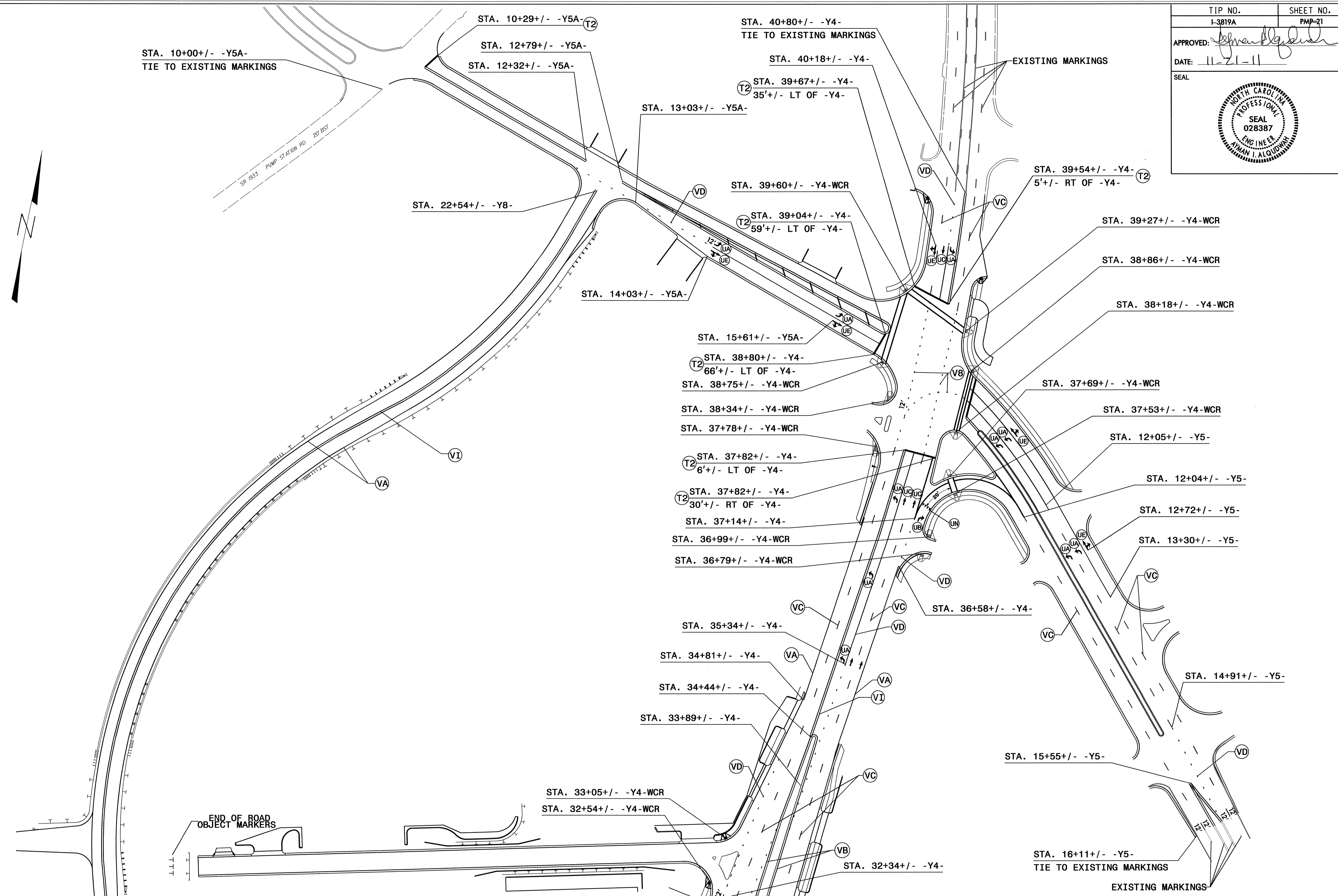

**I 40 / US 21
PAVEMENT MARKING DETAIL**

I:\Projects\2011\11-21-11\I-3819A\T-traffic\Signing\CADD\PMPI-3819A_PMP-21.dgn
 11/21/11 10:45:00 AM
 User: jgmar-tne

MATCHLINE SEE PMP-7