

- TA-E THERMO WHITE EDGELINE (4", 90 mils)
- TB-E THERMO YELLOW EDGELINE (4", 90 mils)
- TC-E THERMO 10' WHITE SKIP (4", 120 mils)
- TD-E THERMO 3'-9"/SP WHITE MINI-SKIP (4" 120 mils)
- T8-E THERMO 2'-6"/SP WHITE MINI-SKIP (4", 120 mils)
- TE-E THERMO WHITE SOLID LANE LINE (4", 120 mils)
- TF-E THERMO 10' YELLOW SKIP (4", 120 mils)
- T2-E THERMO WHITE STOPBAR (24", 120 mils)
- TV-E THERMO WHITE CROSSWALK LINE (8", 120 mils)
- TQ-E THERMO WHITE DIAGONAL (8", 90 mils)
- TT-E THERMO YELLOW DIAGONAL (8", 90 mils)
- UA-E THERMO LEFT TURN ARROW (90 mils)
- UB-E THERMO RIGHT TURN ARROW (90 mils)
- UC-E THERMO STRAIGHT ARROW (90 mils)
- UE-E THERMO COMBO STRAIGHT/RIGHT (90 mils)
- TH-E THERMO YELLOW SINGLE CENTER (4", 120 mils)
- TI-E THERMO YELLOW DOUBLE CENTER (4" 120 mils)
- UC-E THERMO BICYCLE LANE ARROW (90 mils)
- UI-E THERMO ALPHA-NUMERIC CHARACTER (120 mils)
- UK-E THERMO BICYCLE SYMBOL (90 mils)

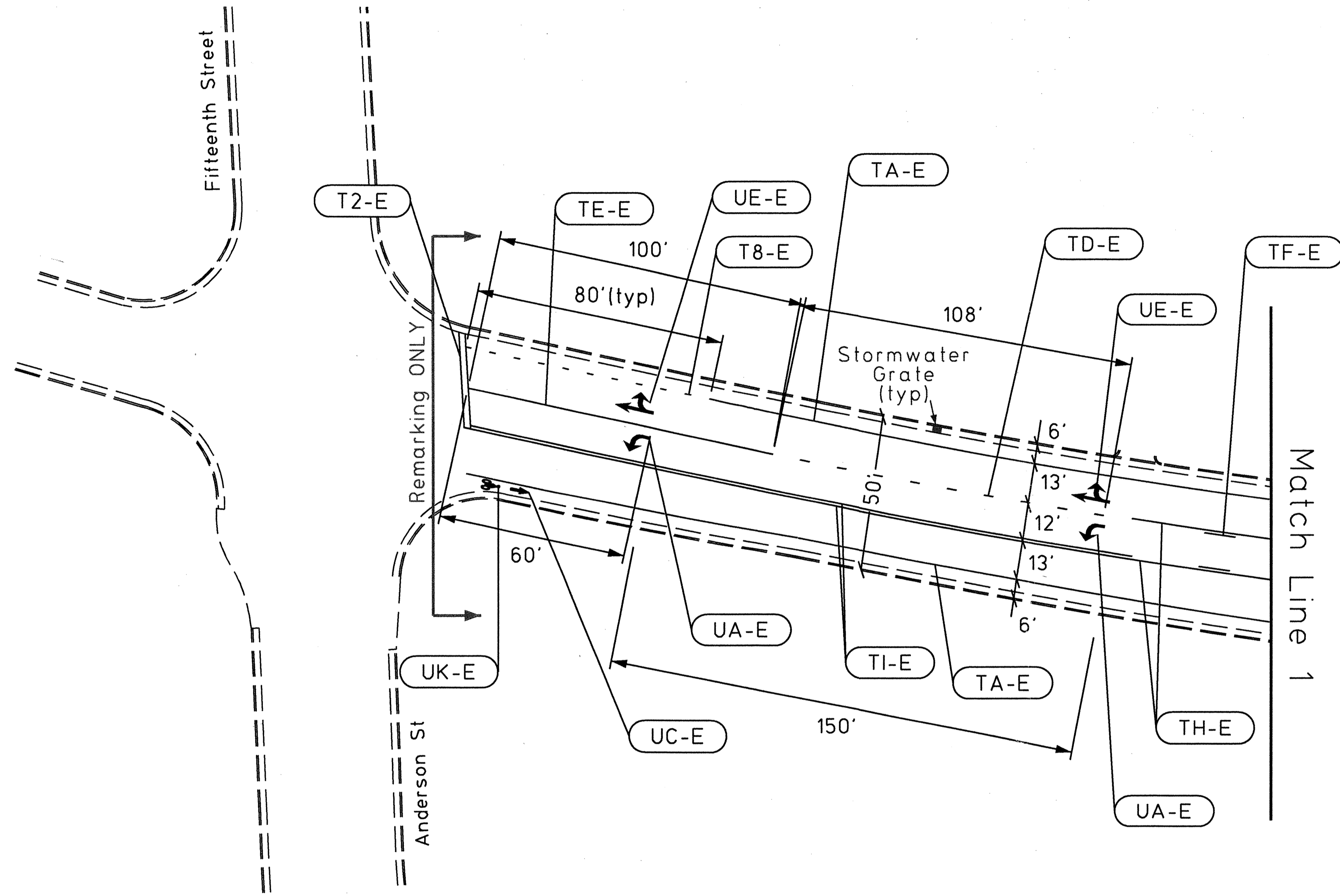

REVISIONS	INIT.	DATE

DURHAM
 City of Durham DOT
 101 City Hall Plaza
 Durham, NC 27701
 (919) 560-4366

Proposed Pavement Marking Plans
 US 70 Business (W Main Street)
 Road Diet

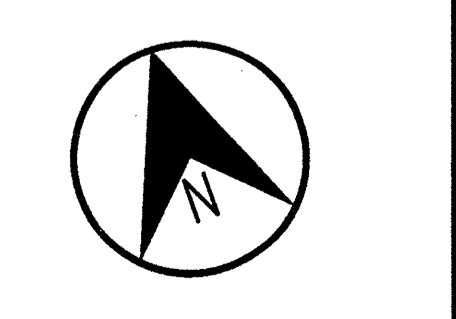
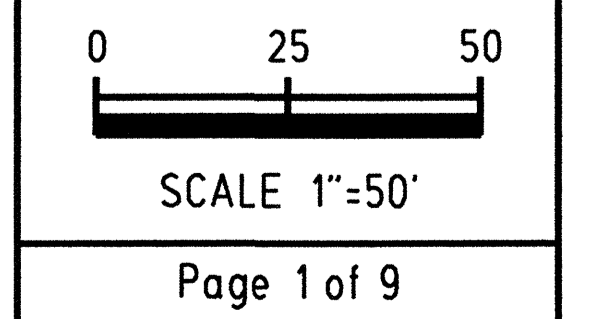

SEAL

1-17-12

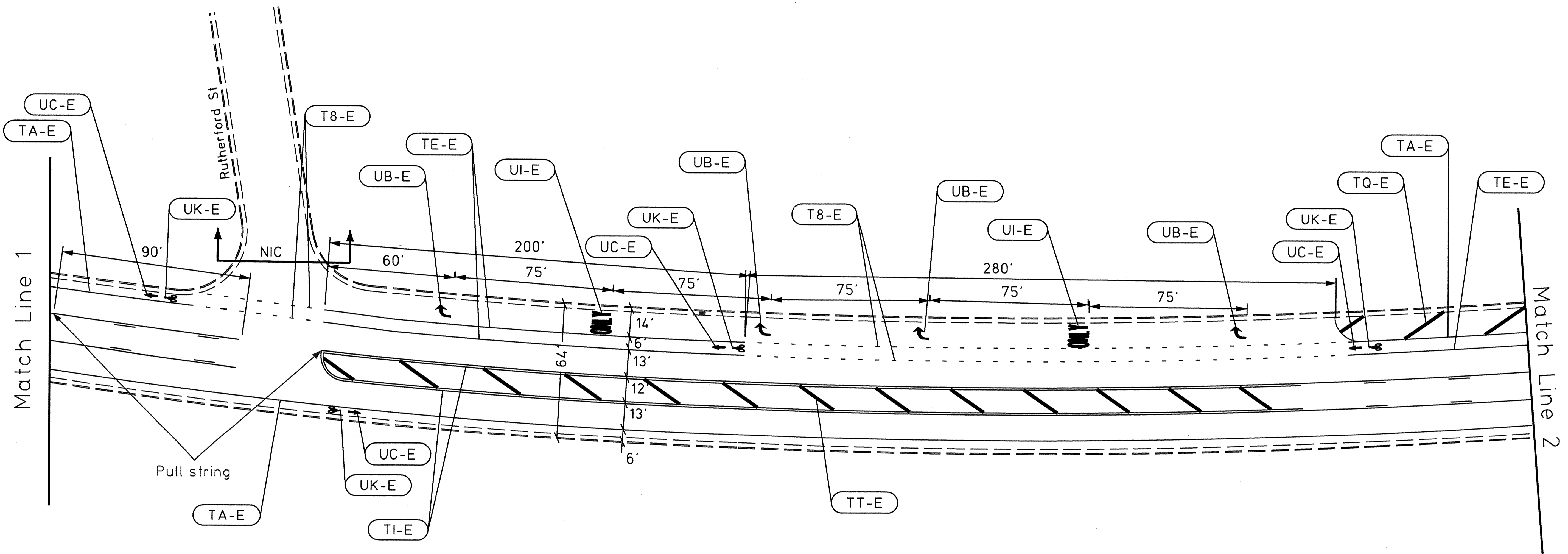

REVISIONS

INIT.

DATE



City of Durham DOT
101 City Hall Plaza
Durham, NC 27701
(919) 560-4366

Proposed Pavement Marking Plans
US 70 Business (W Main Street)
Road Diet

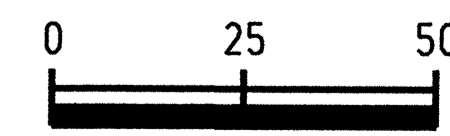

SCALE 1"=50'

Page 2 of 9

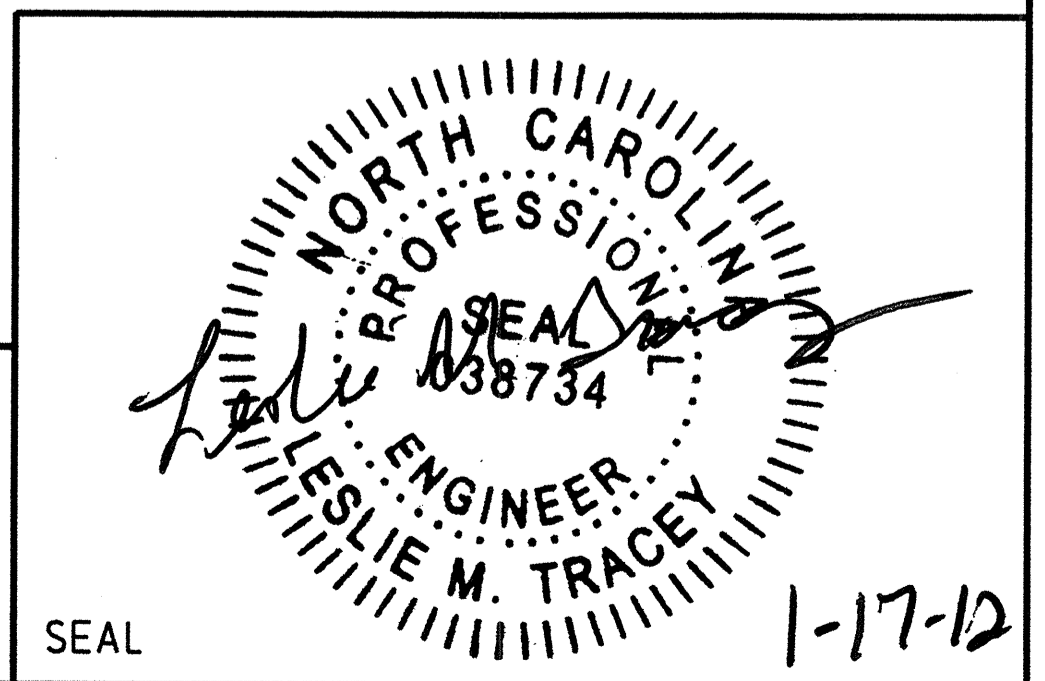
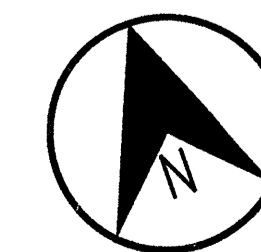

SEAL

1-17-12

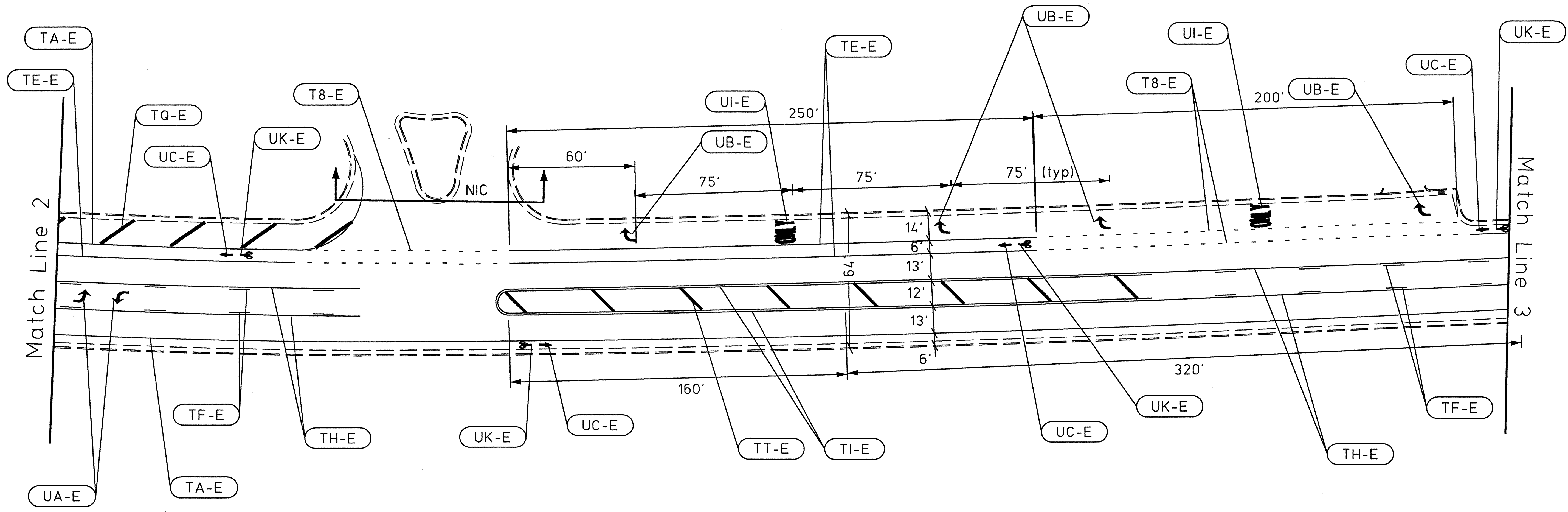

REVISIONS	INIT.	DATE

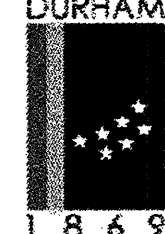
 City of Durham DOT
 101 City Hall Plaza
 Durham, NC 27701
 (919) 560-4366

Proposed Pavement Marking Plans
 US 70 Business (W Main Street)
 Road Diet

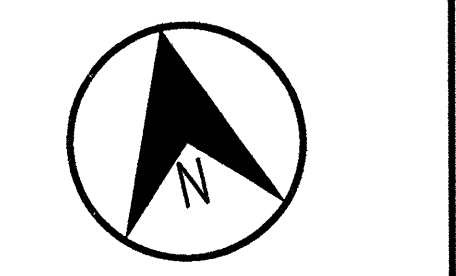
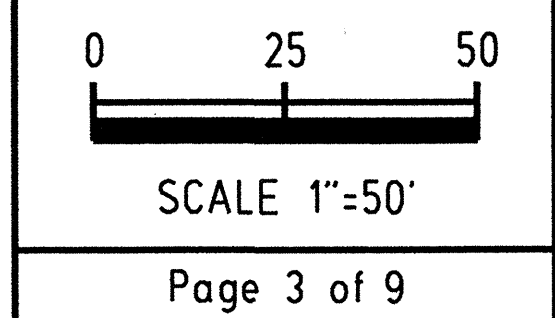

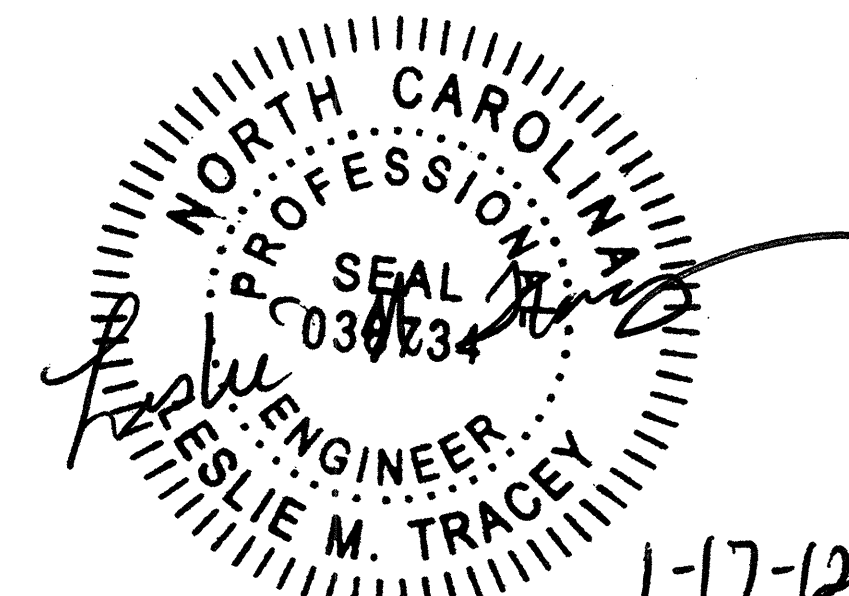
SEAL

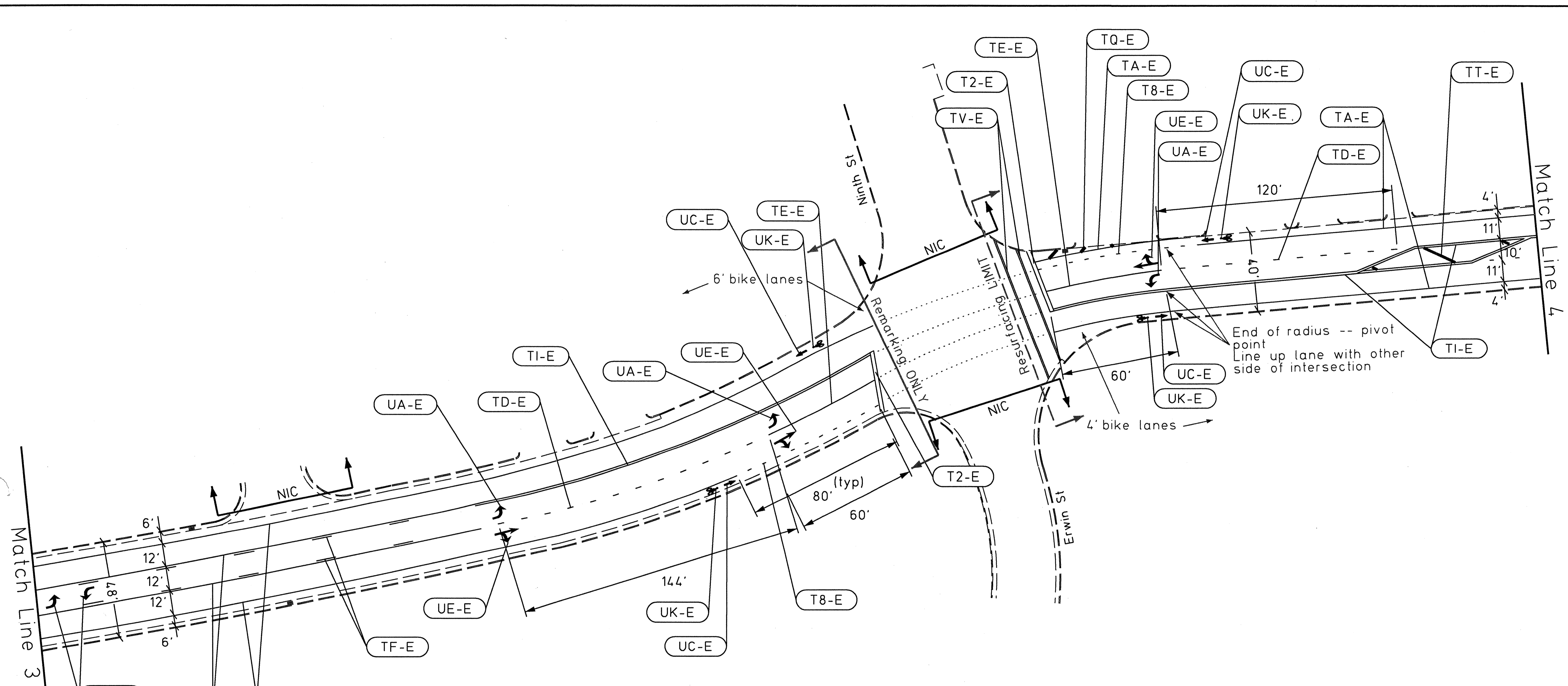
 1-17-12



Note: Crosswalk lines are 8 inches thick with 8 feet of separation. Locate stopbars 4 feet behind and parallel to crosswalks.

REVISIONS	INIT.	DATE

DURHAM
 City of Durham DOT
 101 City Hall Plaza
 Durham, NC 27701
 (919) 560-4366

Proposed Pavement Marking Plans
 US 70 Business (W Main Street)
 Road Diet

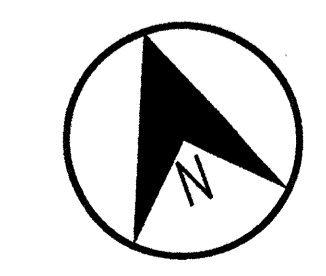
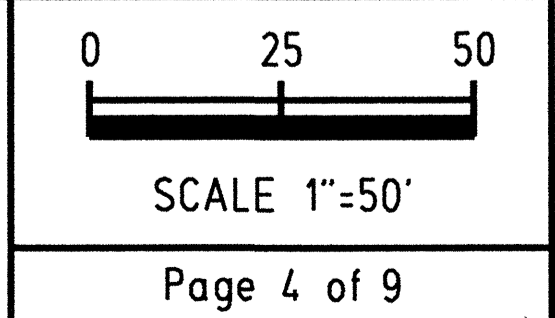

Professional Engineer Seal for Leslie M. Tracey, State of North Carolina, License No. 048734. The seal includes the text 'NORTH CAROLINA PROFESSIONAL ENGINEER SEAL' and 'LESLIE M. TRACEY'. A handwritten signature and the date '1-17-12' are present over the seal.

SEAL

Note: Crosswalk lines are 8 inches thick with 8 feet of separation.
 Locate stopbars 4 feet behind and parallel to crosswalks.

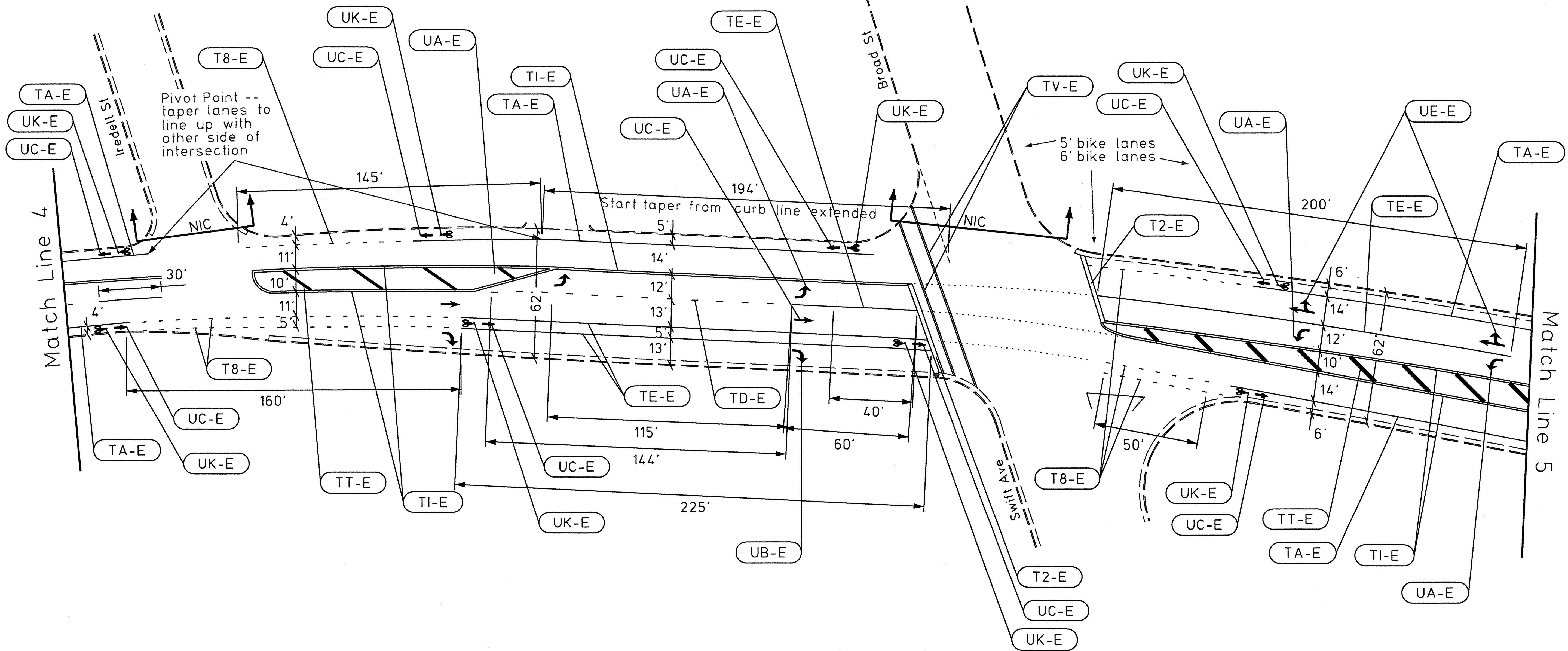

REVISIONS

INIT.

DATE



City of Durham DOT
 101 City Hall Plaza
 Durham, NC 27701
 (919) 560-4366

Proposed Pavement Marking Plans
 US 70 Business (W Main Street)
 Road Diet

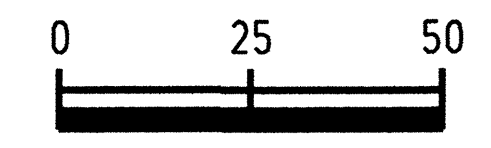

SCALE 1"=50'

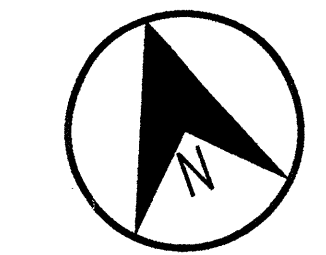

Professional Engineer Seal for Leslie M. Tracey, State of North Carolina, License No. 988734. The seal includes the text "NORTH CAROLINA PROFESSIONAL ENGINEER SEAL" and "LESLIE M. TRACEY".

1-17-12

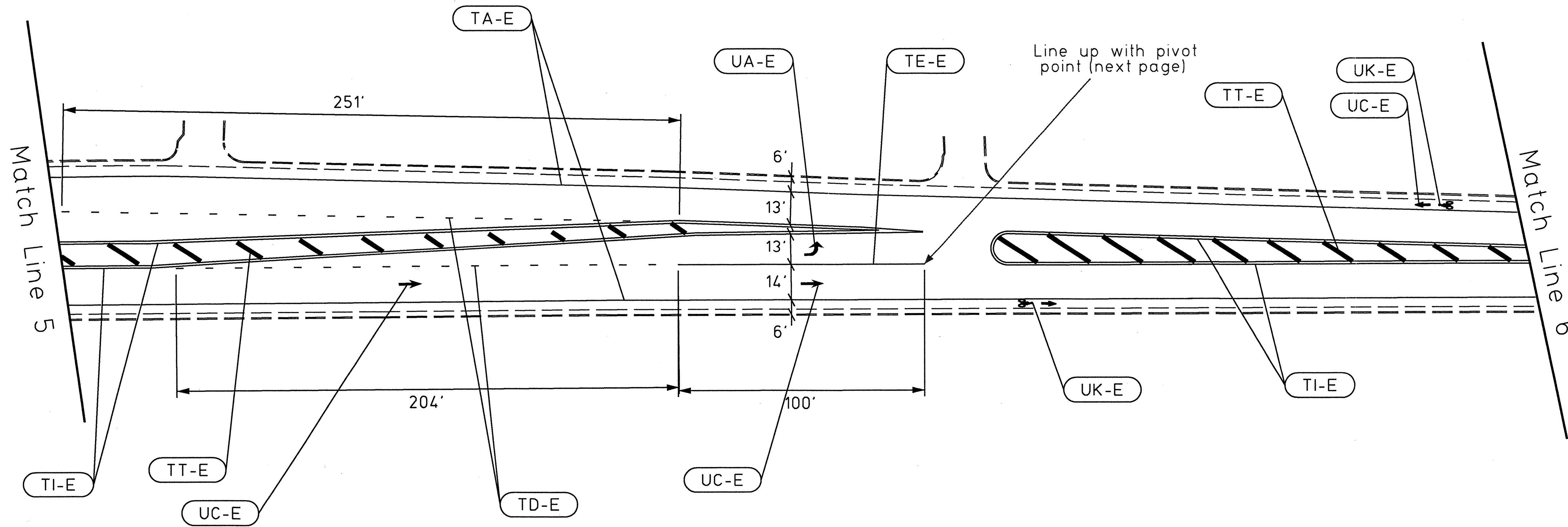

REVISIONS	INIT.	DATE

DURHAM
 City of Durham DOT
 101 City Hall Plaza
 Durham, NC 27701
 (919) 560-4366

Proposed Pavement Marking Plans
 US 70 Business (W Main Street)
 Road Diet

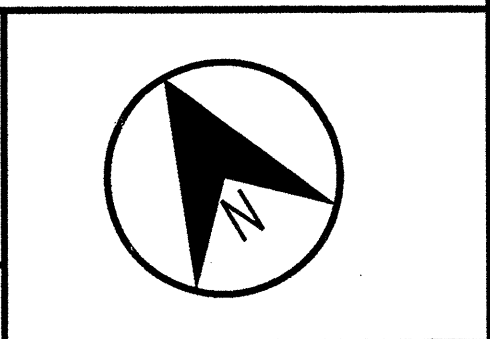
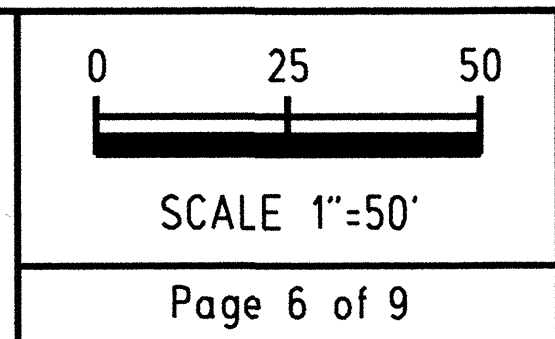

SEAL

1-17-12

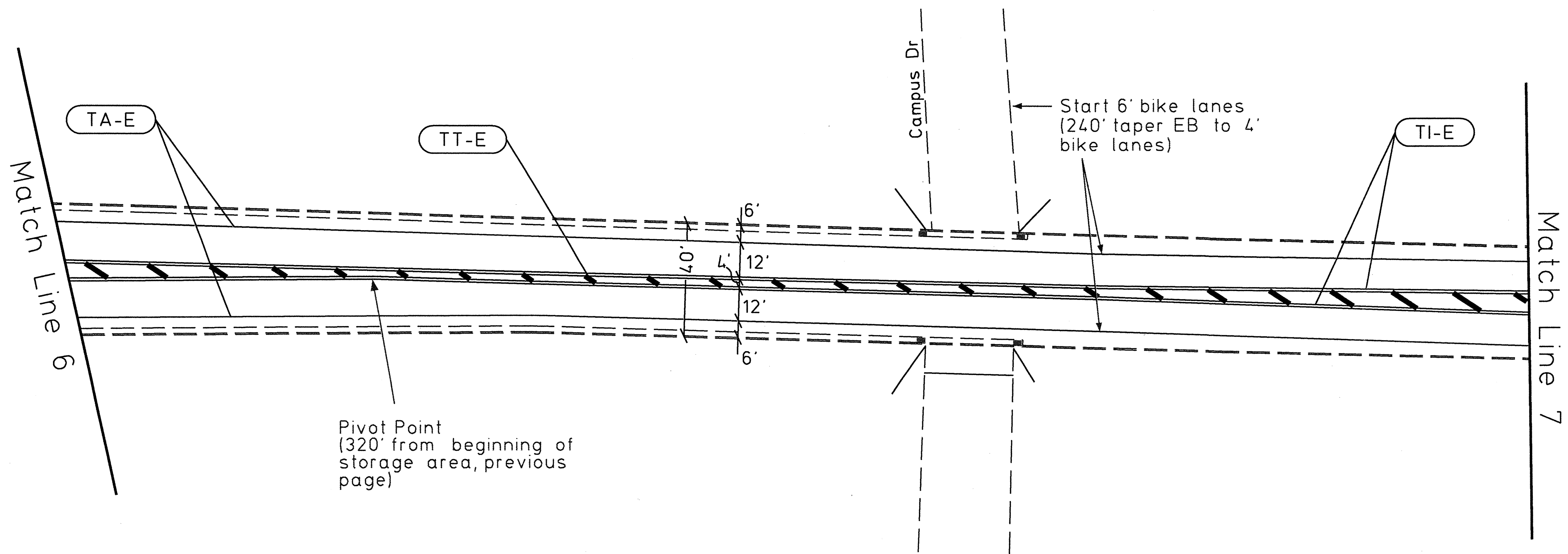

Note: Pavement markings to be cold-applied plastic in lieu of Thermoplastic on concrete surface, as directed by the Engineer.

REVISIONS

INIT.

DATE

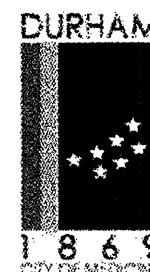

City of Durham DOT
101 City Hall Plaza
Durham, NC 27701
(919) 560-4366

Proposed Pavement Marking Plans
US 70 Business (W Main Street)
Road Diet

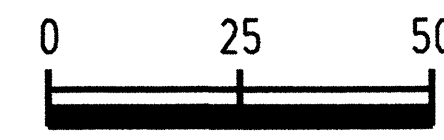

SCALE 1"=50'

Page 7 of 9

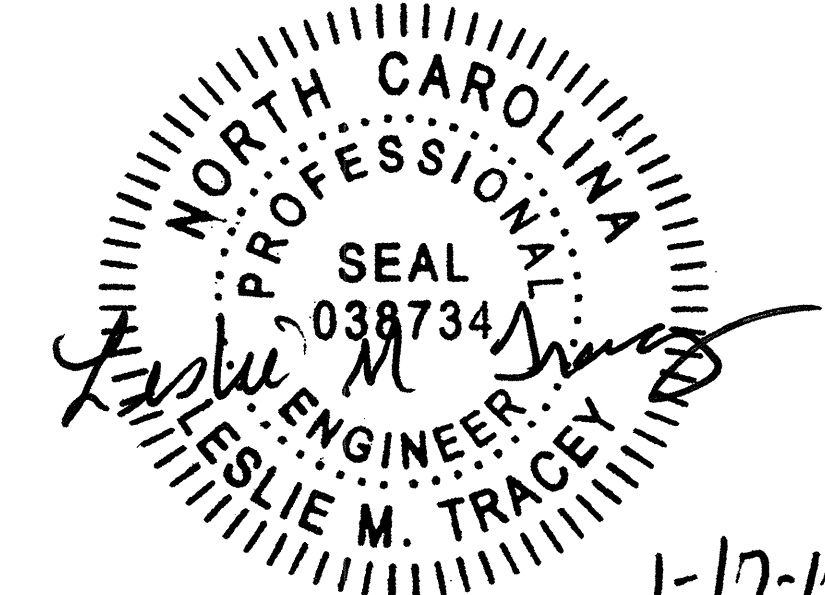
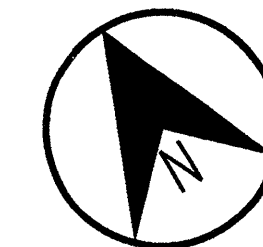

SEAL

1-17-12

Note: Crosswalk lines are 8 inches thick with 8 feet of separation.
 Locate stopbars 4 feet behind and parallel to crosswalks.

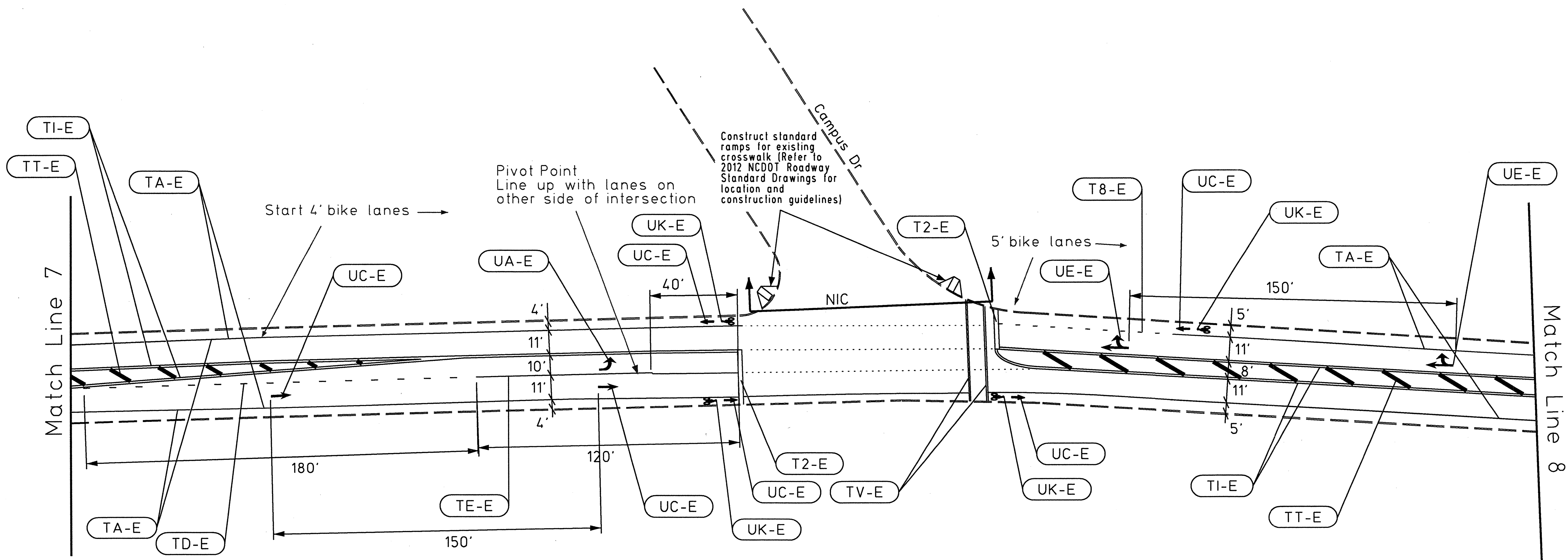

REVISIONS

INIT.

DATE

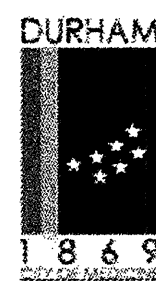

City of Durham DOT
 101 City Hall Plaza
 Durham, NC 27701
 (919) 560-4366

Proposed Pavement Marking Plans
 US 70 Business (W Main Street)
 Road Diet



SCALE 1"=50'

Page 8 of 9

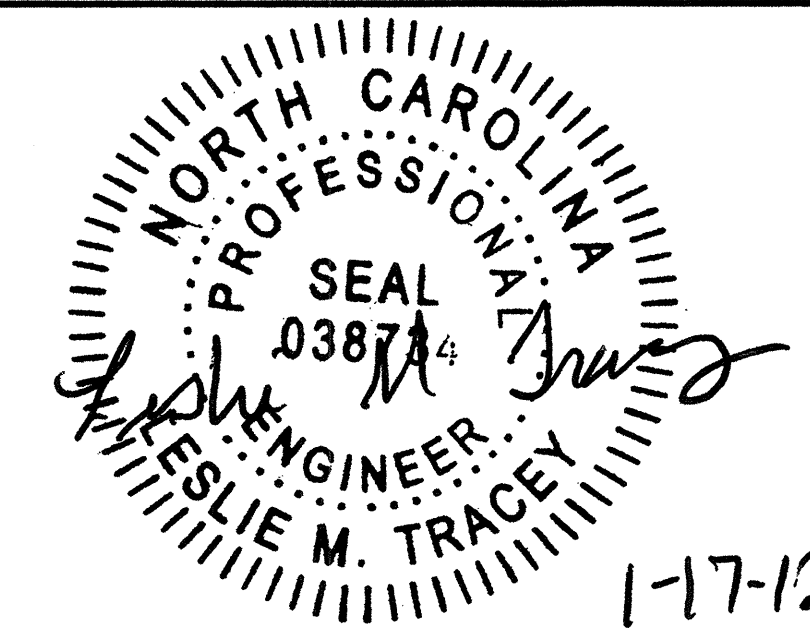
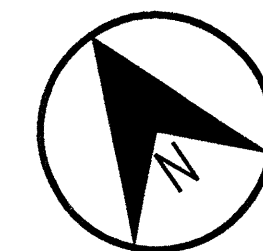

1-17-12

SEAL

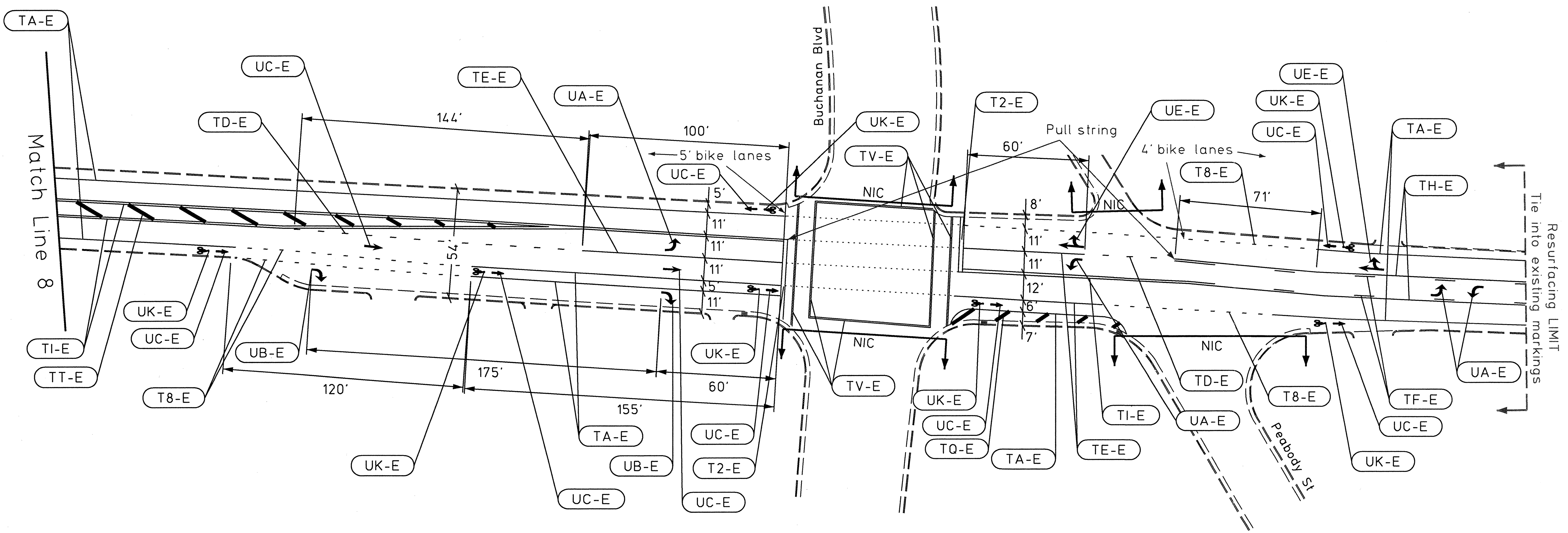

Note: Crosswalk lines are 8 inches thick with 8 feet of separation.
 Locate stopbars 4 feet behind and parallel to crosswalks.

REVISIONS	INIT.	DATE

DURHAM
 City of Durham DOT
 101 City Hall Plaza
 Durham, NC 27701
 (919) 560-4366

Proposed Pavement Marking Plans
 US 70 Business (W Main Street)
 Road Diet

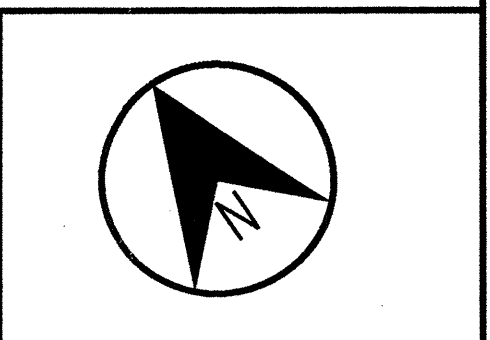
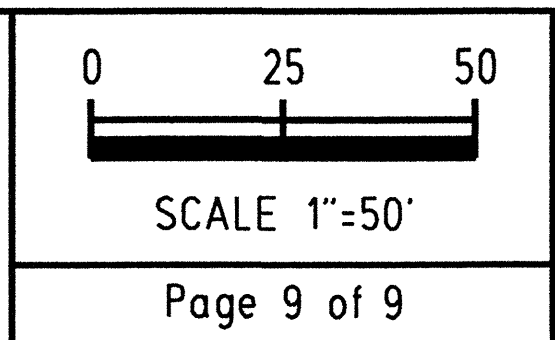

Professional Engineer Seal for Leslie M. Tracey, North Carolina. The seal is circular with the text 'NORTH CAROLINA PROFESSIONAL ENGINEER' around the perimeter and 'SEAL 03/13/34' in the center. A signature is written over the seal. The date '1-17-12' is written to the right of the seal. The word 'SEAL' is printed at the bottom left of the block.