

STATE	PROJECT NO.	SHEET NO.	TOTAL SHEETS
N.C.		I	
PROJECT NO.		IOCR.10601.66, ETC.	

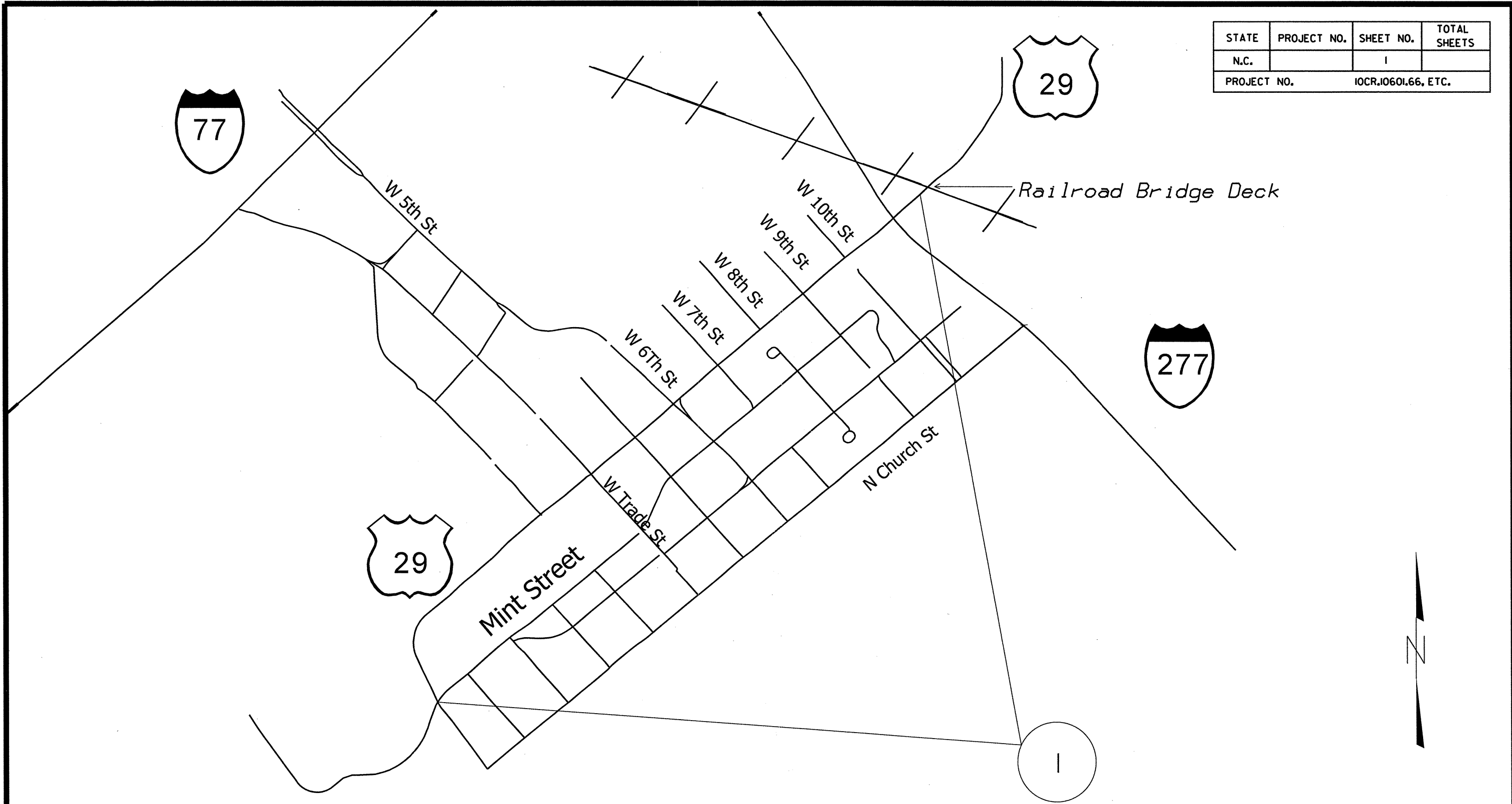

MAP

# 1 US 29 (Graham Street)

DESCRIPTION

FROM RR Bridge Deck N. of I-277 TO  
Mint St.

2012/2013 MECKLENBURG COUNTY RESURFACING			
SCALE	-NA-		REVISIONS
DATE	12/11		
DWG. BY	JHW		
DESIGN BY	JSL		
APPROVED	LLW		

STATE	PROJECT NO.	SHEET NO.	TOTAL SHEETS
N.C.		2	
PROJECT NO.		10CR.10601.66, ETC.	

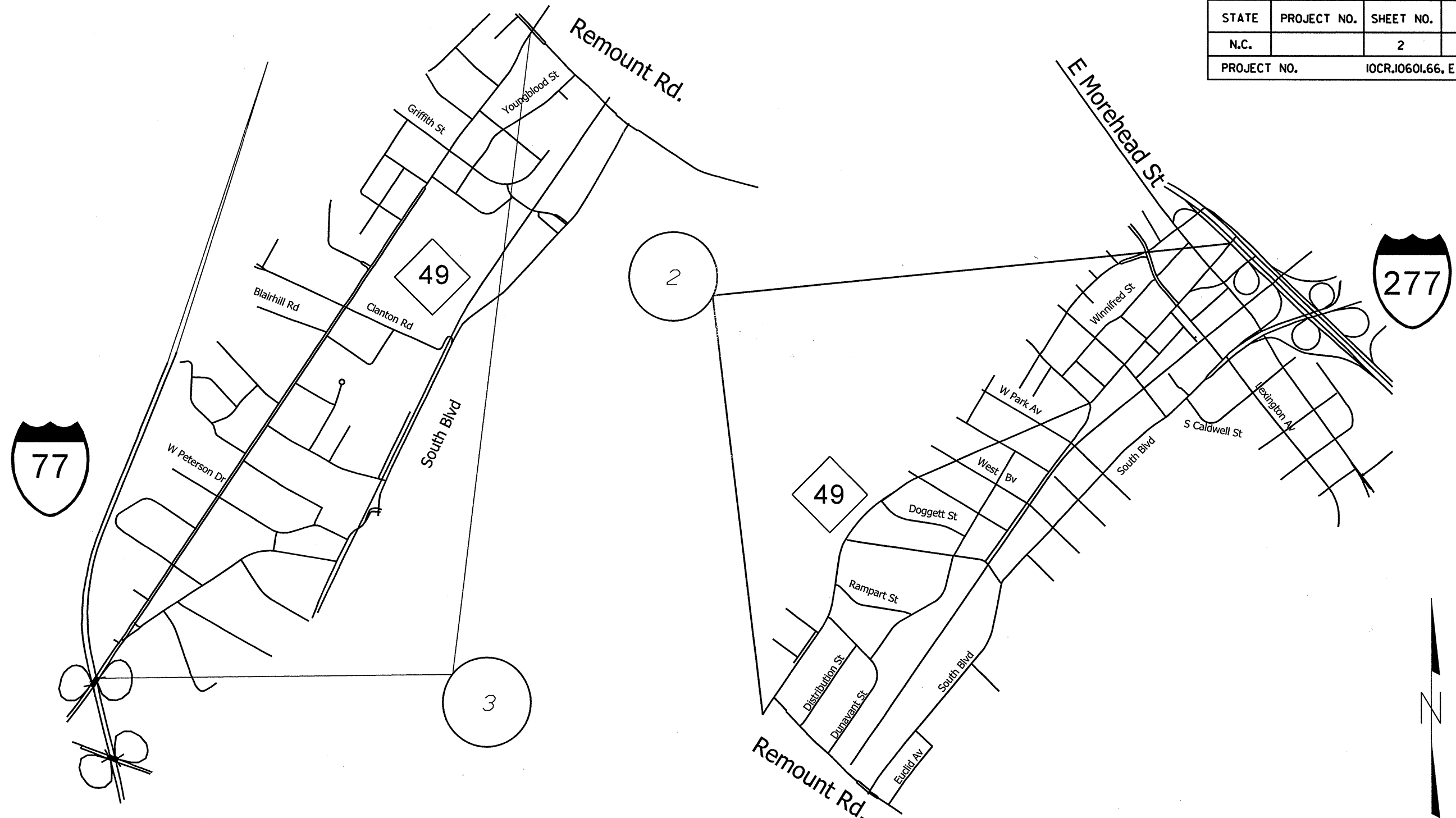

MAP

DESCRIPTION

- # 2 NC 49 (Tryon Street)
- # 3 NC 49 (Tryon Street)

FROM Remount Rd TO Morehead St.  
 FROM Remount Rd TO I-77

2012/2013 MECKLENBURG COUNTY RESURFACING			
SCALE	-NA-		REVISIONS
DATE	12/11		
DWG. BY	JHW		
DESIGN BY	JSL		
APPROVED	LLM		

STATE	PROJECT NO.	SHEET NO.	TOTAL SHEETS
N.C.		3	
PROJECT NO.		IOCR.10601.66, ETC.	

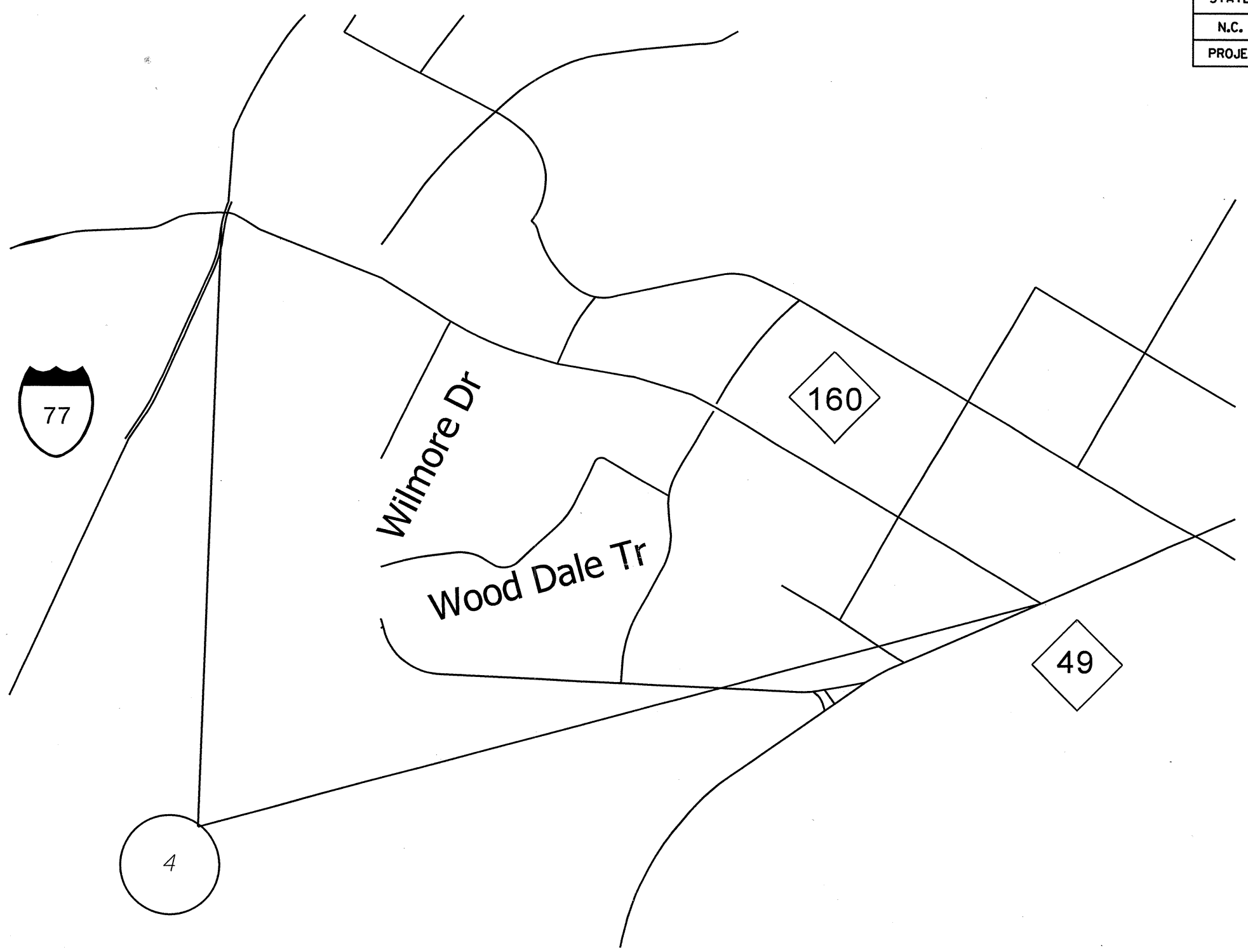

MAP

# 4 (NC 160)

DESCRIPTION

FROM I-77 TO NC 49

2012/2013 MECKLENBURG COUNTY  
RESURFACING

SCALE	-NA-		REVISIONS
DATE	12/11		
DWG. BY	JHW		
DESIGN BY	JSL		
APPROVED	LLM		

STATE	PROJECT NO.	SHEET NO.	TOTAL SHEETS
N.C.		4	
PROJECT NO.		IOCR.10601.66, ETC.	

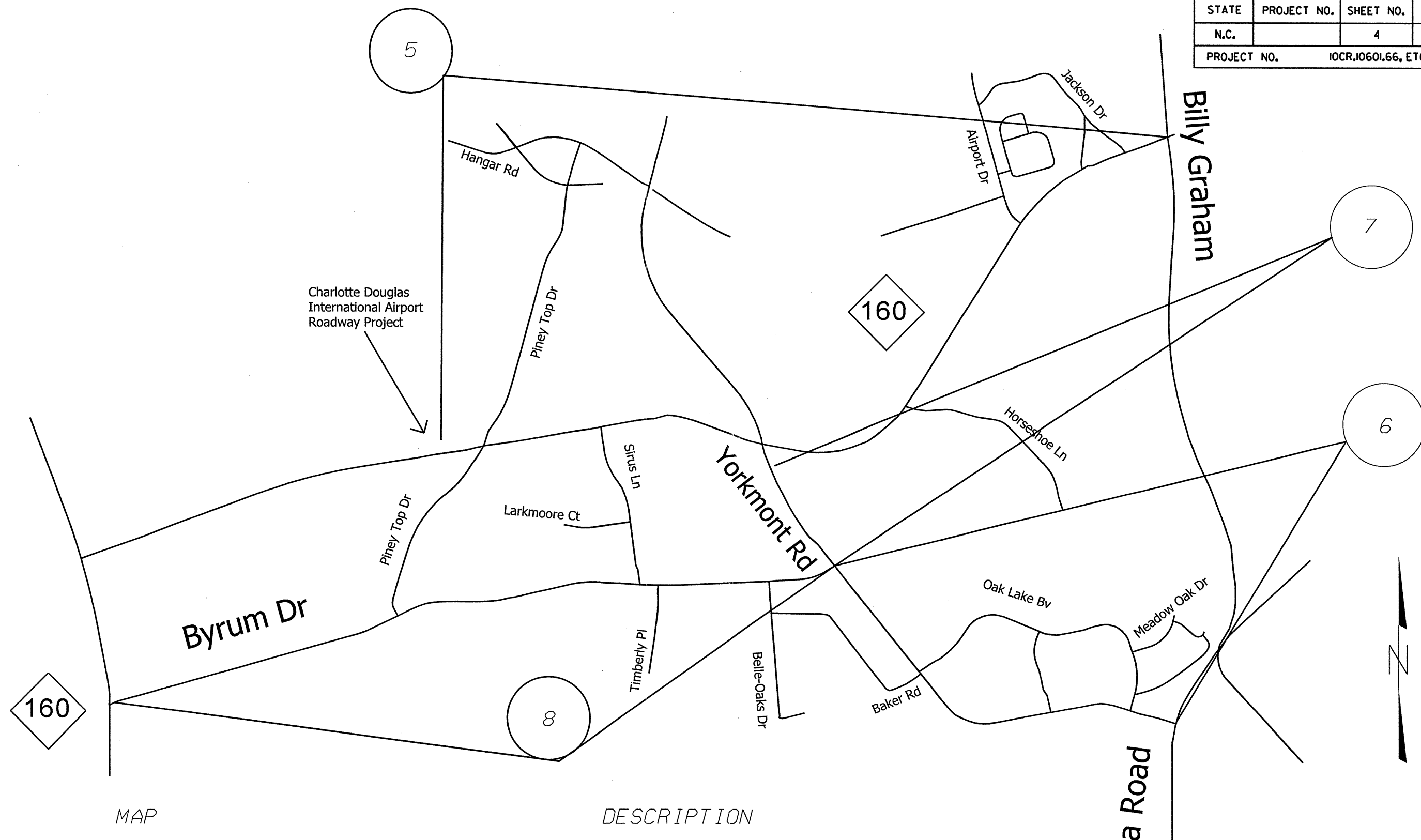

MAP

DESCRIPTION

- # 5 NC 160
- # 6 SR 1156 (Yorkmont Rd)
- # 7 SR 1156 (Yorkmont Rd)
- # 8 SR 1255 (Byrum Drive)

- FROM Billy Graham TO Airport Work
- FROM Byrum Dr TO Tyvola Rd
- FROM Byrum Dr TO NC 160
- FROM NC 160 TO Yorkmont Rd

2012/2013 MECKLENBURG COUNTY RESURFACING		
SCALE	-NA-	REVISIONS
DATE	12/11	
DWG. BY	JHW	
DESIGN BY	JSL	
APPROVED	LLM	



STATE	PROJECT NO.	SHEET NO.	TOTAL SHEETS
N.C.		5	
PROJECT NO.		IOCR.10601.66. ETC.	

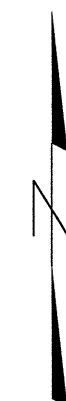
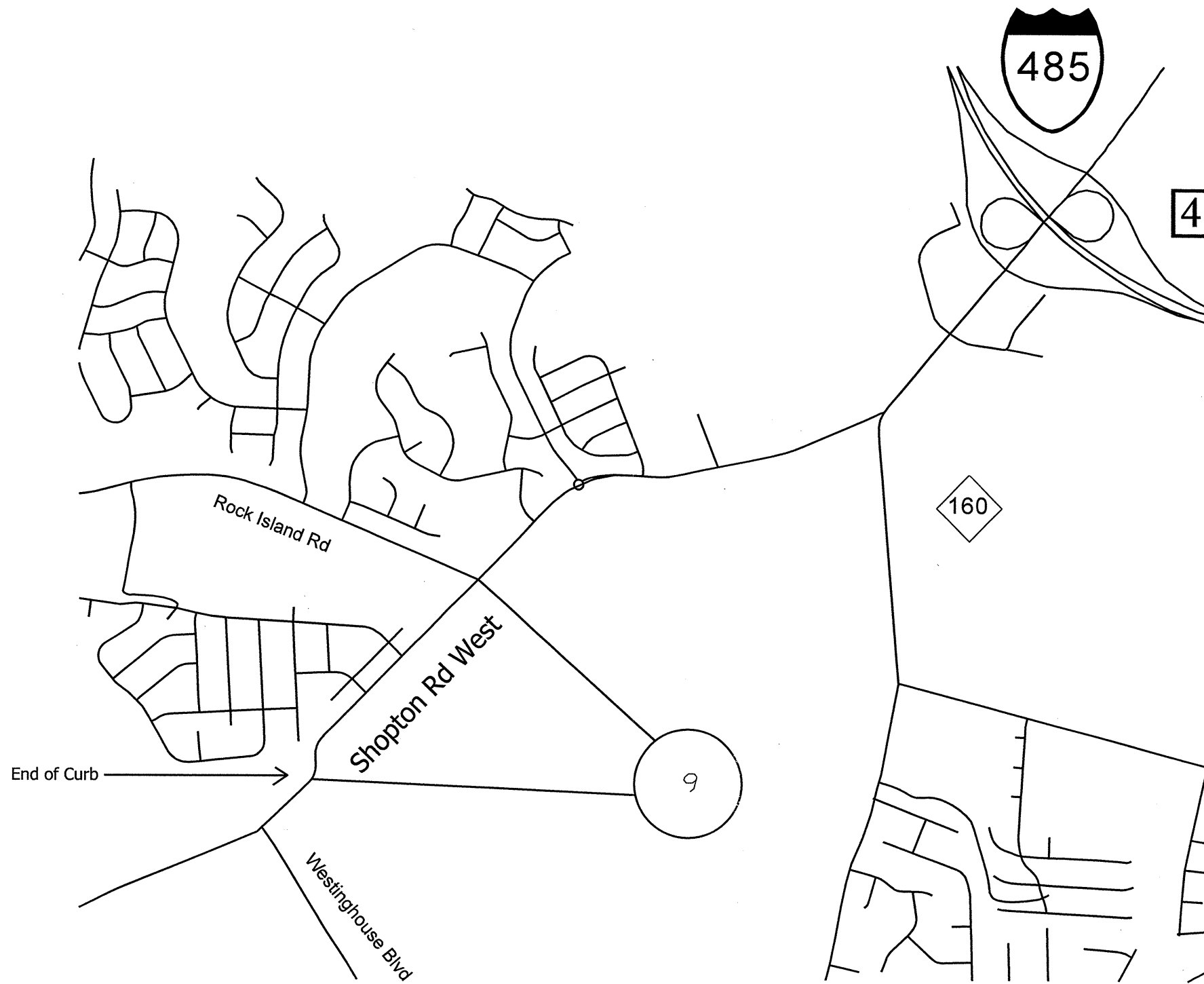

MAP

DESCRIPTION

# 9 SR 1116 (Shopton Rd West)

FROM Rock Island Rd TO End of Curb

2012/2013 MECKLENBURG COUNTY  
RESURFACING

SCALE -NA-  
DATE 12/11  
DWG. BY JHW  
DESIGN BY JSL  
APPROVED LLW



REVISIONS	

STATE	PROJECT NO.	SHEET NO.	TOTAL SHEETS
N.C.		6	
PROJECT NO.		IOCR.10601.66, ETC.	

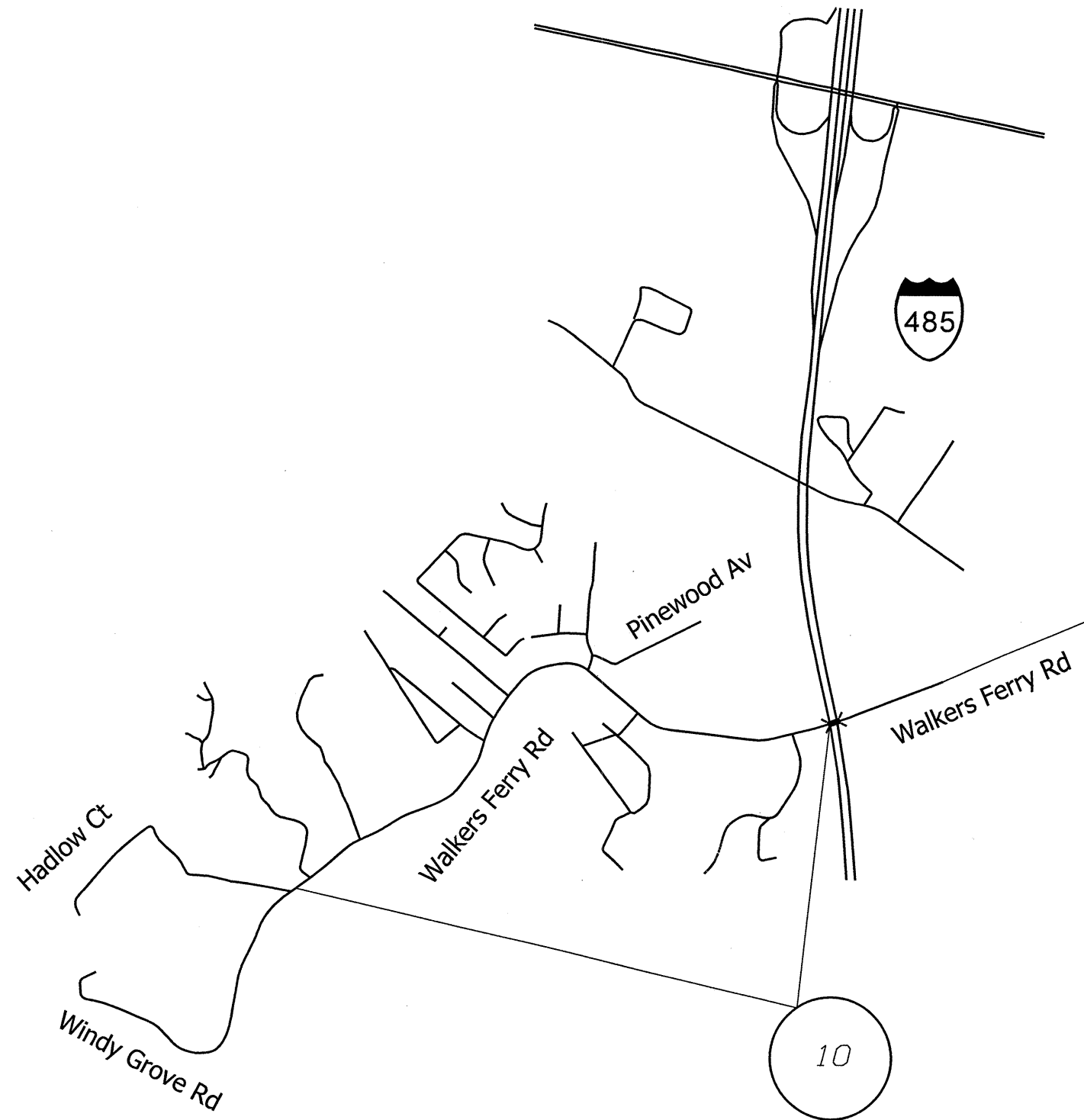

MAP

DESCRIPTION

# 10 SR 1193 (Walkers Ferry Rd)

FROM Pvmnt Jnt at I 485 Bridge TO Pvmnt Jnt at Hallow Court

2012/2013 MECKLENBURG COUNTY RESURFACING			
SCALE	-NA-		REVISIONS
DATE	12/11		
DWG. BY	JHW		
DESIGN BY	JSL		
APPROVED	LLM		

STATE	PROJECT NO.	SHEET NO.	TOTAL SHEETS
N.C.		7	
PROJECT NO.		IOCR.10601.66, ETC.	

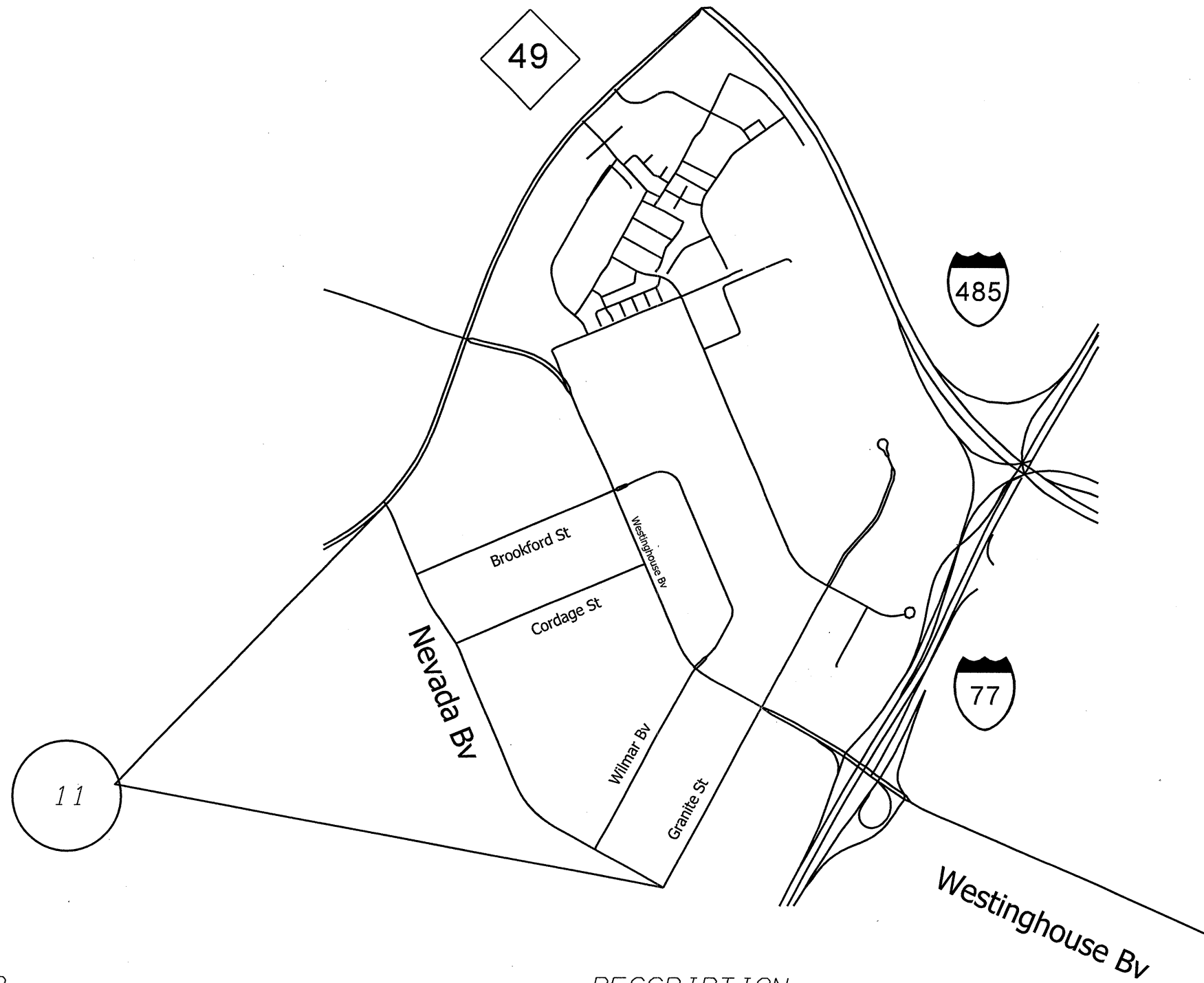

MAP

DESCRIPTION

# 11 SR 1347 (Nevada Bv)

FROM NC 49 TO End of State Maint.

2012/2013 MECKLENBURG COUNTY  
RESURFACING

SCALE	-NA-		REVISIONS
DATE	12/11		
DWG. BY	JHW		
DESIGN BY	JSL		
APPROVED	LLM		

STATE	PROJECT NO.	SHEET NO.	TOTAL SHEETS
N.C.	8	8	
PROJECT NO.		IOCR.10601.66, ETC.	

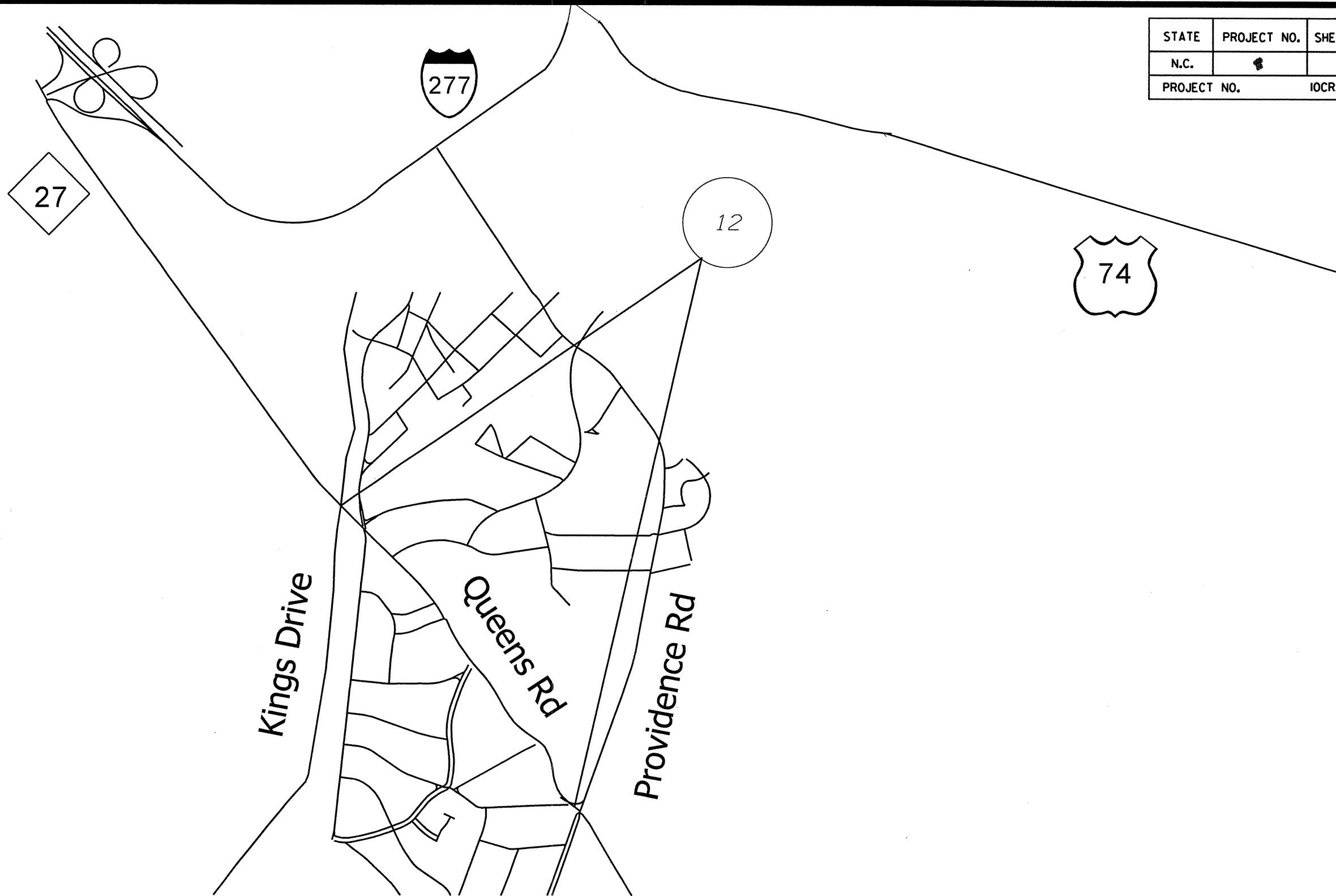

MAP

DESCRIPTION

# 12 SR 3815 (Queens Rd)

FROM S. Kings Drive TO Providence Rd

2012/2013 MECKLENBURG COUNTY RESURFACING		
SCALE	-NA-	
DATE	12/11	
DWG. BY	JHW	
DESIGN BY	JSL	
APPROVED	LLM	
		REVISIONS



STATE	PROJECT NO.	SHEET NO.	TOTAL SHEETS
N.C.		9	
PROJECT NO.		10CRJ060.66, ETC.	

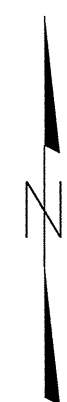
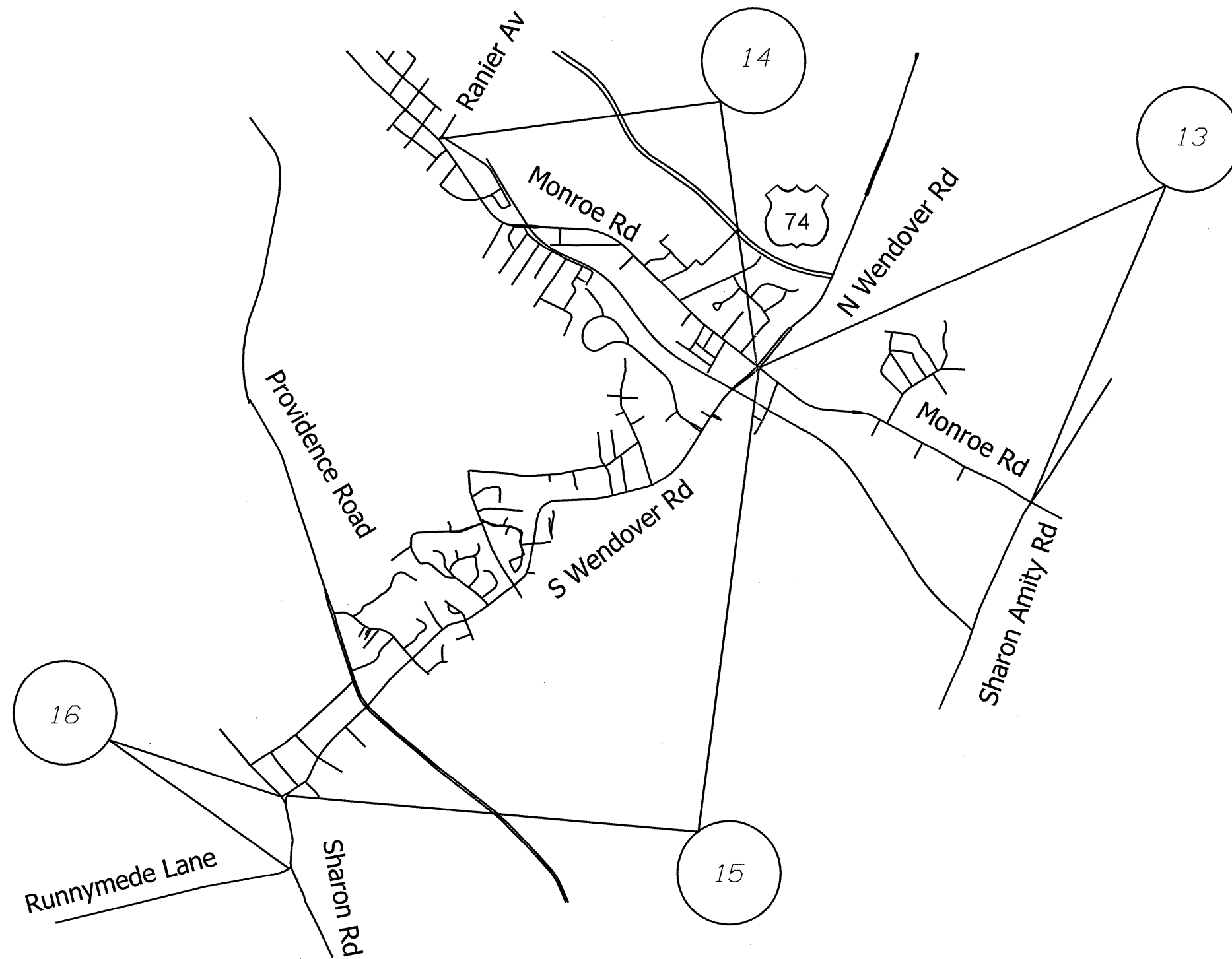

MAP

DESCRIPTION

# 13 SR 1009 (Monroe Rd)	FROM Wendover Rd	TO Sharon Amity Rd
# 14 SR 3300 (Monroe Rd)	FROM Wendover Rd	TO Ranier Ave
# 15 SR 3585 & 3600 (Wendover Rd)	FROM Monroe Rd	TO Sharon Rd
# 16 SR 3600 (Sharon Rd)	FROM Wendover Rd	TO Runnymede Lane

2012/2013 MECKLENBURG COUNTY  
RESURFACING

SCALE	-NA-
DATE	12/11
DWG. BY	JW
DESIGN BY	JSL
APPROVED	LLM



REVISIONS	

2012 ROADWAY ENGLISH STANDARD DRAWINGS

The following Roadway Standards as appear in "Roadway Standard Drawings" Highway Design Branch  
 N. C. Department of Transportation - Raleigh, N. C., Dated January, 2012 are applicable to this project  
 and by reference hereby are considered a part of these plans:

STD.NO. TITLE  
 DIVISION 8 - INCIDENTALS  
 848.06 Curb Ramp - Existing Curb & Gutter

STATE	PROJECT NO.	SHEET NO.	TOTAL SHEETS
N.C.		10	
PROJECT NO.		IOCR.I0601.66. ETC.	

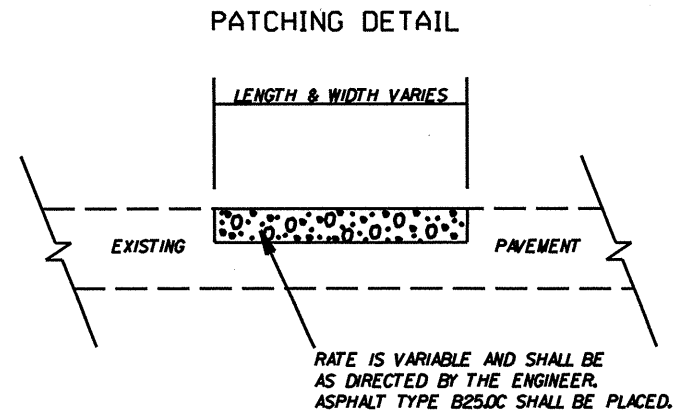

PAVEMENT SCHEDULE	
C1	PROP. APPROX. 1.5" ASPHALT CONCRETE SURFACE COURSE, TYPE S9.5C, AT AN AVERAGE RATE OF 168 LBS. PER SQ. YD.
D1	PROP. APPROX. 2.5" ASPHALT CONCRETE INTERMEDIATE COURSE, TYPE I19.0C, AT AN AVERAGE RATE OF 285 LBS. PER SQ. YD.
T1	SHOULDER RECONSTRUCTION.
V1	MILLING 1.5" DEPTH
V2	PROFILE MILLING 0" TO 1.5"
V3	PROFILE MILLING 0" TO 2.5"

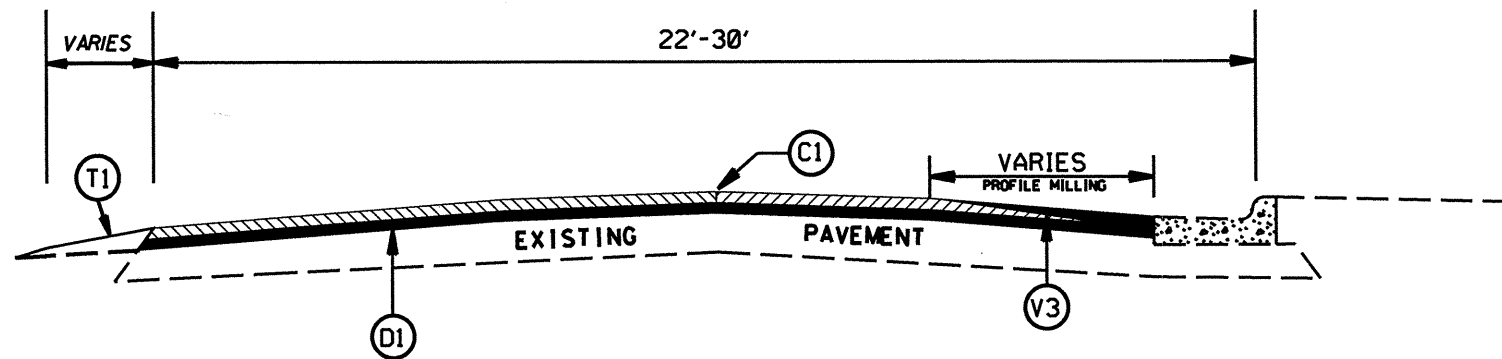

TYPICAL SECTION NO. 10

2012/2013 MECKLENBURG COUNTY RESURFACING			
SCALE	-HA-		REVISIONS
DATE	12/11		
DWG. BY	JHW		
DESIGN BY	JSL		
APPROVED	LLM		

STATE	PROJECT NO.	SHEET NO.	TOTAL SHEETS
N.C.		11	
PROJECT NO.		IOCR.10601.66, ETC.	

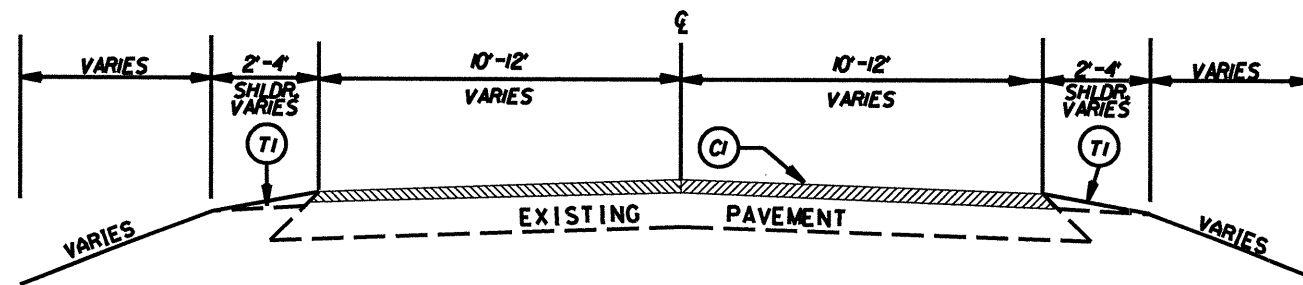

TYPICAL SECTION NO. 9

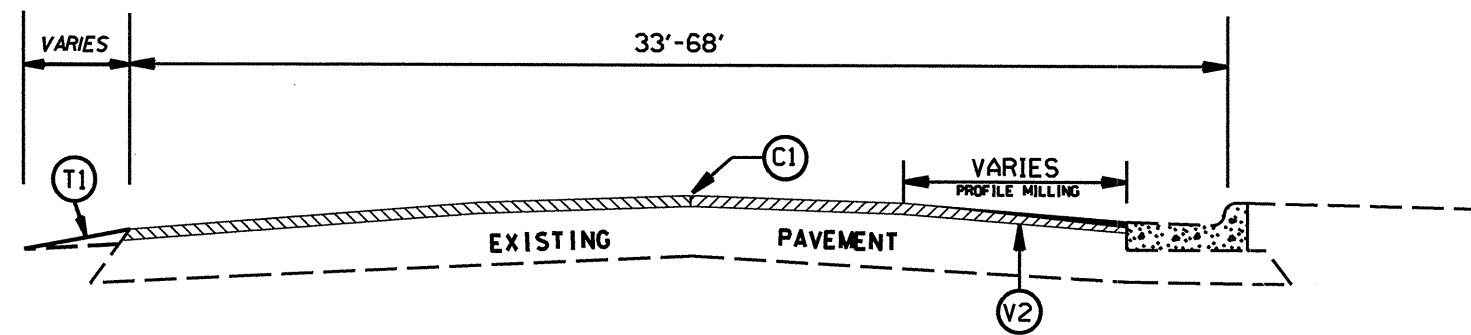

TYPICAL SECTION NO. 8

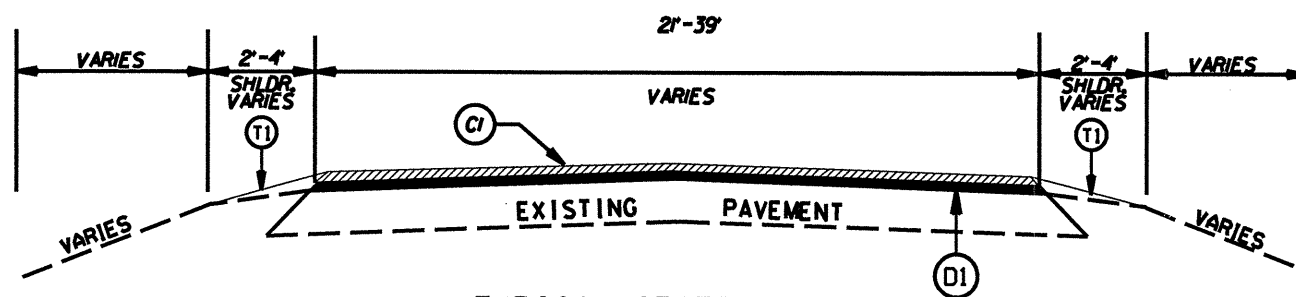

TYPICAL SECTION NO. 7

PAVEMENT SCHEDULE	
C1	PROP. APPROX. 1.5" ASPHALT CONCRETE SURFACE COURSE, TYPE S9.5C, AT AN AVERAGE RATE OF 168 LBS. PER SQ. YD.
D1	PROP. APPROX. 2.5" ASPHALT CONCRETE INTERMEDIATE COURSE, TYPE I19.0C, AT AN AVERAGE RATE OF 285 LBS. PER SQ. YD.
T1	SHOULDER RECONSTRUCTION.
V1	MILLING 1.5" DEPTH
V2	PROFILE MILLING 0" TO 1.5"
V3	PROFILE MILLING 0" TO 2.5"

2012/2013 MECKLENBURG COUNTY  
RESURFACING

SCALE	-NA-		REVISIONS
DATE	12/11		
DWG. BY	JSL		
DESIGN BY	JSL		
APPROVED	LLM		

STATE	PROJECT NO.	SHEET NO.	TOTAL SHEETS
N.C.		12	
PROJECT NO.		IOCR.10601.66, ETC.	

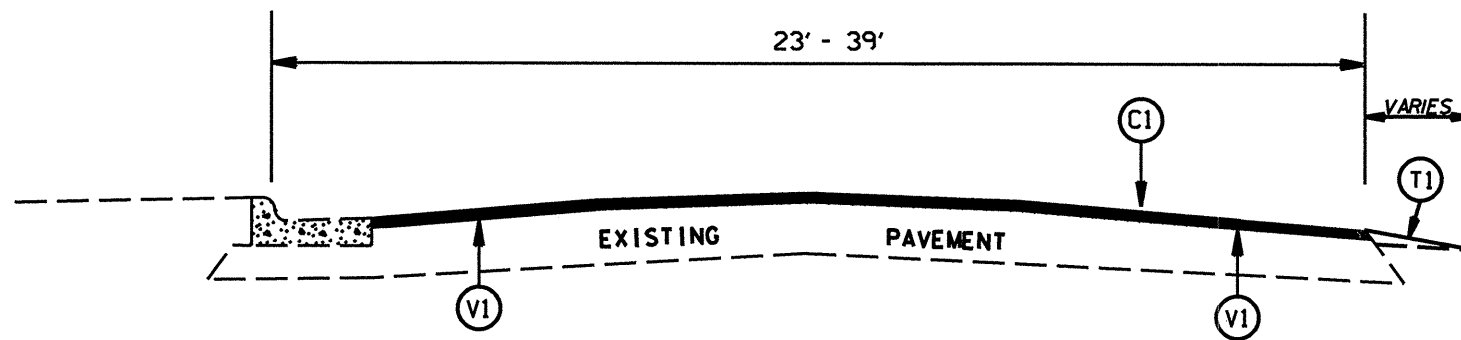

TYPICAL SECTION NO. 6

PAVEMENT SCHEDULE	
C1	PROP. APPROX. 1.5" ASPHALT CONCRETE SURFACE COURSE, TYPE S9.5C, AT AN AVERAGE RATE OF 168 LBS. PER SQ. YD.
D1	PROP. APPROX. 2.5" ASPHALT CONCRETE INTERMEDIATE COURSE, TYPE I19.0C, AT AN AVERAGE RATE OF 285 LBS. PER SQ. YD.
T1	SHOULDER RECONSTRUCTION.
V1	MILLING 1.5" DEPTH
V2	PROFILE MILLING 0" TO 1.5"
V3	PROFILE MILLING 0" TO 2.5"

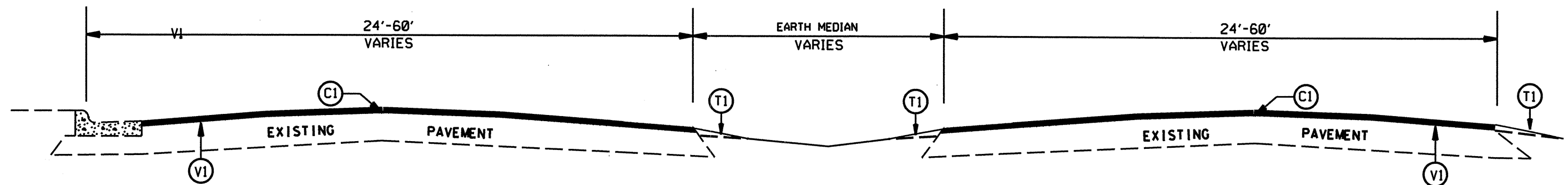

TYPICAL SECTION NO. 5

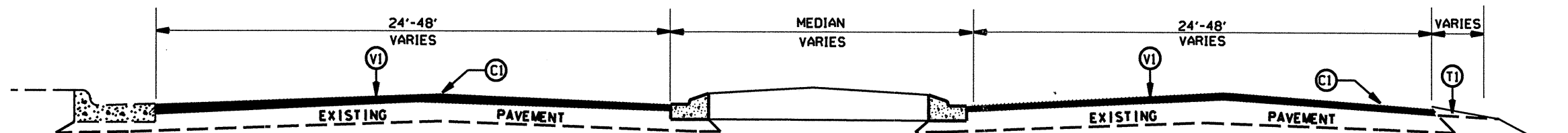

TYPICAL SECTION NO. 4

2012/2013 MECKLENBURG COUNTY  
RESURFACING

SCALE	-NA-		REVISIONS
DATE	12/11		
DWG. BY	JSL		
DESIGN BY	JSL		
APPROVED	LLM		

STATE	PROJECT NO.	SHEET NO.	TOTAL SHEETS
N.C.		13	
PROJECT NO.		IOCR.I060I.66, ETC.	

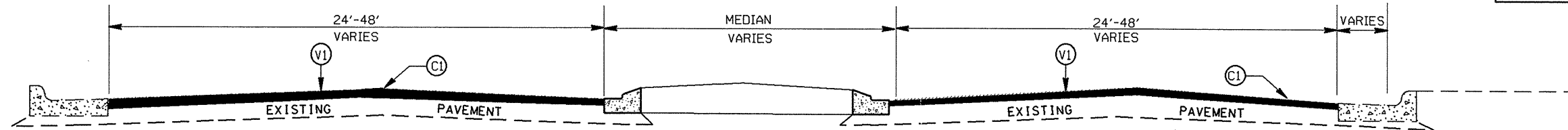

TYPICAL SECTION NO.3

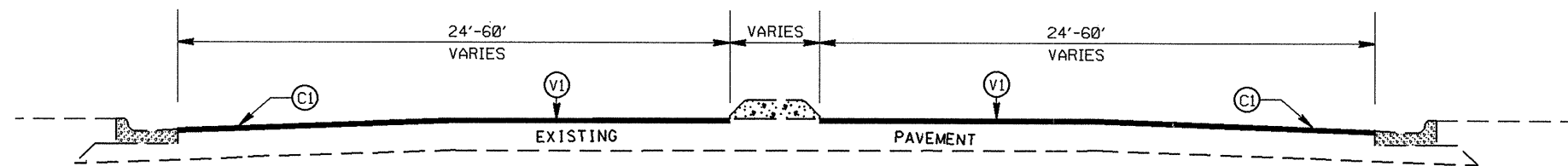

TYPICAL SECTION NO.2

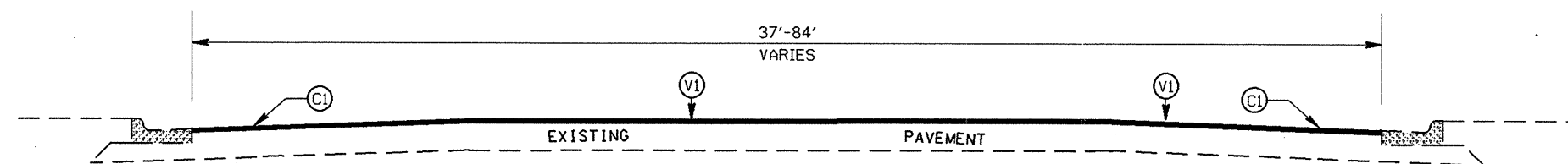

TYPICAL SECTION NO.1

PAVEMENT SCHEDULE	
C1	PROP. APPROX. 1.5" ASPHALT CONCRETE SURFACE COURSE, TYPE S9.5C, AT AN AVERAGE RATE OF 168 LBS. PER SQ. YD.
D1	PROP. APPROX. 2.5" ASPHALT CONCRETE INTERMEDIATE COURSE, TYPE I19.0C, AT AN AVERAGE RATE OF 285 LBS. PER SQ. YD.
T1	SHOULDER RECONSTRUCTION.
V1	MILLING 1.5" DEPTH
V2	PROFILE MILLING 0" TO 1.5"
V3	PROFILE MILLING 0" TO 2.5"

2012/2013 MECKLENBURG COUNTY  
RESURFACING

SCALE -NA-  
DATE 12/11  
DWG. BY JSL  
DESIGN BY JSL  
APPROVED LLM



REVISIONS	

PROJECT NO. 10CR.10601.66, ETC.	SHEET NO. 14	TOTAL NO.
---------------------------------------	-----------------	-----------

## SUMMARY OF QUANTITIES

PROJECT NO	COUNTY	MAP NO	ROUTE	DESCRIPTION	TYP	FINAL SURFACE TESTING REQUIRED	AGGREGATE SHOULDER BORROW ALLOWED	LENGTH MI	WIDTH FT	BORROW CY	INCIDENTAL STONE BASE TONS	SHOULDER RECONSTRUCTION SMI	1 1/2" MILLING SY	0" TO 2.5" MILLING SY	0" TO 1.5" MILLING SY	INCIDENTAL MILLING SY	INTER-MEDIATE COURSE, I19.0C TONS	SURFACE COURSE, S9.5C TONS	LEVELING COURSE, S9.5C TONS	ASPHALT BINDER FOR PLANT MIX TONS	PATCHING EXISTING PAVEMENT TONS	RETROFIT EXISTING CURB RAMP EA	ADJ. OF MAN-HOLES EA	ADJ. OF METER OR VALVE BOX EA	PORTABLE LIGHTING LS	TEMPORARY SILT FENCE LF	STONE FOR EROSION CONTROL, CLASS B TN	SEDIMENT CONTROL STONE TN	MATTING (EROSION CONTROL) SY	WATTLE LF	POLY-ACRYLAMIDE (PAM) LB					
10CR.10601.66	Mecklenburg	1	GRAHAM STREET (US 29)	FROM RR BRIDGE DECK TO MINT STREET	1	NO	NO	1.08	43.5				27,562					2,554		151	500	30	15	10	*											
<b>TOTAL FOR PROJ NO. 10CR.10601.66</b>								<b>1.08</b>	<b>43.5</b>				<b>27,562</b>					<b>2,554</b>		<b>151</b>	<b>500</b>	<b>30</b>	<b>15</b>	<b>10</b>												
10CR.10601.67	Mecklenburg	2	S. TRYON ST (NC 49)	FROM REMOUNT RD TO MOREHEAD STREET (SR 3815)	1	NO	NO	1.55	48.5				44,103					4,086		241	1,200	31	15	15	*											
<b>TOTAL FOR PROJ NO. 10CR.10601.67</b>								<b>1.55</b>	<b>48.5</b>				<b>44,103</b>					<b>4,086</b>		<b>241</b>	<b>1,200</b>	<b>31</b>	<b>15</b>	<b>15</b>												
10CR.10601.68	Mecklenburg	3	S. TRYON STREET (NC 49)	FROM I-77 TO REMOUNT RD	1, 2	NO	NO	1.89	55				60,984					5,648		333	1,420	30	10	8	*											
<b>TOTAL FOR PROJ NO. 10CR.10601.68</b>								<b>1.89</b>	<b>55</b>				<b>60,984</b>					<b>5,648</b>		<b>333</b>	<b>1,420</b>	<b>30</b>	<b>10</b>	<b>8</b>												
10CR.10601.69	Mecklenburg	4	WEST BLVD (NC 160)	FROM I-77 TO S. TRYON ST (NC 49)	1, 2	NO	NO	0.69	49				19,835					1,837		108	520	23			*											
<b>TOTAL FOR PROJ NO. 10CR.10601.69</b>								<b>0.69</b>	<b>49</b>				<b>19,835</b>					<b>1,837</b>		<b>108</b>	<b>520</b>	<b>23</b>														
10CR.10601.70	Mecklenburg	5	WEST BLVD (NC 160)	FROM BILLY GRAHAM PKWY (SR 5901) TO PVT JT AT THE LIMITS OF THE AIRPORT PROJECT	1, 3, 4, 5, 6, 7	NO	YES	1.9	48	100	50	2.80	26,752			600	2,295	4,957	700	448	1,200	7	5		*	95	24	24	10	15	1					
<b>TOTAL FOR PROJ NO. 10CR.10601.70</b>								<b>1.9</b>	<b>48</b>	<b>100</b>	<b>50</b>	<b>2.80</b>	<b>26,752</b>			<b>600</b>	<b>2,295</b>	<b>4,957</b>	<b>700</b>	<b>448</b>	<b>1,200</b>	<b>7</b>	<b>5</b>					<b>95</b>	<b>24</b>	<b>24</b>	<b>10</b>	<b>15</b>	<b>1</b>			
10CR.20601.135	Mecklenburg	6	YORKMONT RD (SR 1156)	FROM BYRUM DR (SR 1255) TO TVOLA RD	2, 6	NO	YES	0.8	49	50		0.60	22,997					2,130		126	550	3	2	6												
<b>TOTAL FOR PROJ NO. 10CR.20601.135</b>								<b>0.8</b>	<b>49</b>	<b>50</b>		<b>0.60</b>	<b>22,997</b>					<b>2,130</b>		<b>126</b>	<b>550</b>	<b>3</b>	<b>2</b>	<b>6</b>												
10CR.20601.136	Mecklenburg	7	YORKMONT RD (SR 1156)	FROM BYRUM DR (SR 1255) TO WEST BLVD (NC 160)	1, 2	NO	NO	0.24	55				7,744					717		42	150	3		2		25	3	3	10	10	1					
<b>TOTAL FOR PROJ NO. 10CR.20601.136</b>								<b>0.24</b>	<b>55</b>				<b>7,744</b>					<b>717</b>		<b>42</b>	<b>150</b>	<b>3</b>		<b>2</b>		<b>25</b>	<b>3</b>	<b>3</b>	<b>10</b>	<b>10</b>	<b>1</b>					
10CR.20601.137	Mecklenburg	8	BYRUM DRIVE (SR 1255)	FROM STEELE CREEK RD (NC 160) TO YORKMONT RD (SR 1156)	7,10	NO	YES	1.25	25	300	100	2.10		1,150		350	2,898	1,702		240	950	2		6		125	16	16	10	20	1					
<b>TOTAL FOR PROJ NO. 10CR.20601.137</b>								<b>1.25</b>	<b>25</b>	<b>300</b>	<b>100</b>	<b>2.10</b>		<b>1,150</b>		<b>350</b>	<b>2,898</b>	<b>1,702</b>		<b>240</b>	<b>950</b>	<b>2</b>		<b>240</b>	<b>950</b>	<b>2</b>		<b>6</b>		<b>125</b>	<b>16</b>	<b>16</b>	<b>10</b>	<b>20</b>	<b>1</b>	
10CR.20601.138	Mecklenburg	9	SHOPTON RD WEST (SR 1116)	FROM ROCK ISLAND RD TO END OF CURB AND GUTTER	8, 9	NO	YES	0.42	28.5	50	30	0.55		1,750	125		652	300	58	325					25	6	6	5	10	0.5						
<b>TOTAL FOR PROJ NO. 10CR.20601.138</b>								<b>0.42</b>	<b>28.5</b>	<b>50</b>	<b>30</b>	<b>0.55</b>		<b>1,750</b>	<b>125</b>		<b>652</b>	<b>300</b>	<b>58</b>	<b>325</b>								<b>25</b>	<b>6</b>	<b>6</b>	<b>5</b>	<b>10</b>	<b>0.5</b>			
10CR.20601.139	Mecklenburg	10	WALKERS FERRY RD (SR 1193)	FROM PAVEMENT JOINT AT I-485 BRIDGE TO WINDY GROVE RD	9	NO	YES	1.4	21	200	100	2.80			125		1,603	600	134	600					140	18	18	20	30	1						
<b>TOTAL FOR PROJ NO. 10CR.20601.139</b>								<b>1.4</b>	<b>21</b>	<b>200</b>	<b>100</b>	<b>2.80</b>			<b>125</b>		<b>1,603</b>	<b>600</b>	<b>134</b>	<b>600</b>									<b>140</b>	<b>18</b>	<b>18</b>	<b>20</b>	<b>30</b>	<b>1</b>		
10CR.20601.140	Mecklenburg	11	NEVADA BLVD (SR 1347)	FROM S. TRYON ST (NC 49) TO END OF MAINTENANCE	7,10	NO	YES	1.24	26	300	100	2.50		1,500	1,750	2,989	1,756		247	500	3				*	65	32	32	5	10	1					
<b>TOTAL FOR PROJ NO. 10CR.20601.140</b>								<b>1.24</b>	<b>26</b>	<b>300</b>	<b>100</b>	<b>2.50</b>		<b>1,500</b>	<b>1,750</b>	<b>2,989</b>	<b>1,756</b>		<b>247</b>	<b>500</b>	<b>3</b>									<b>65</b>	<b>32</b>	<b>32</b>	<b>5</b>	<b>10</b>	<b>1</b>	
10CR.20601.141	Mecklenburg	12	QUEENS RD (SR 3815)	FROM S. KINGS DRIVE TO PROVIDENCE RD (NC 16)	1, 2	NO	NO	0.8	50				23,467					2,174		128	400	31														
<b>TOTAL FOR PROJ NO. 10CR.20601.141</b>								<b>0.8</b>	<b>50</b>				<b>23,467</b>				<b>2,174</b>		<b>128</b>	<b>400</b>	<b>31</b>															
10CR.20601.142	Mecklenburg	13	MONROE RD (SR 1009)	FROM WENDOVER RD (SR 3585) TO SHARON AMITY RD	1, 2	NO	NO	1.22	55.5				39,723					3,679		217	1,000	27	20	10												
<b>TOTAL FOR PROJ NO. 10CR.20601.142</b>								<b>1.22</b>	<b>55.5</b>				<b>39,723</b>				<b>3,679</b>		<b>217</b>	<b>1,000</b>	<b>27</b>	<b>20</b>	<b>10</b>													
10CR.20601.143	Mecklenburg	14	MONROE RD 7TH ST (SR 3300)	FROM WENDOVER RD (SR 3585) TO RANIER RD	1, 2	NO	NO	1.8	48.5				51,216					4,745		280	1,350	43	25	10												
<b>TOTAL FOR PROJ NO. 10CR.20601.143</b>								<b>1.8</b>	<b>48.5</b>				<b>51,216</b>				<b>4,745</b>		<b>280</b>	<b>1,350</b>	<b>43</b>	<b>25</b>	<b>10</b>													
10CR.20601.144	Mecklenburg	15	WENDOVER RD (SR 3585 & 3600)	FROM MONROE RD (SR 1009) TO SHARON RD (SR 3600)	1, 2	NO	NO	2.62	55				84,539					7,829		462	1,100	35	12	8												
<b>TOTAL FOR PROJ NO. 10CR.20601.144</b>								<b>2.62</b>	<b>55</b>				<b>84,539</b>				<b>7,829</b>		<b>462</b>	<b>1,100</b>	<b>35</b>	<b>12</b>	<b>8</b>													
10CR.20601.145	Mecklenburg	16	SHARON RD (SR 3600)	FROM WENDOVER RD (SR 3600) TO RUNNYMEDE LANE (SR 3814)	1	NO	NO	0.29	66				11,229					1,040		61	150	10	10	2												
<b>TOTAL FOR PROJ NO. 10CR.20601.145</b>								<b>0.29</b>	<b>66</b>				<b>11,229</b>				<b>1,040</b>		<b>61</b>	<b>150</b>	<b>10</b>	<b>10</b>	<b>2</b>													
<b>GRAND TOTAL</b>								<b>19.19</b>		<b>1,000</b>	<b>380</b>	<b>11.35</b>	<b>420,151</b>	<b>2,650</b>	<b>1,750</b>	<b>2,950</b>	<b>8,182</b>	<b>47,109</b>	<b>1,600</b>	<b>3,276</b>	<b>11,915</b>	<b>278</b>	<b>114</b>	<b>77</b>	<b>1</b>	<b>475</b>	<b>99</b>	<b>99</b>	<b>60</b>	<b>95</b>	<b>5.5</b>					

PROJECT NO. 10CR.10601.66, ETC.	SHEET NO. 15	TOTAL NO.
---------------------------------------	-----------------	-----------

### THERMOPLASTIC AND PAINT QUANTITIES

PROJECT NO	COUNTY	MAP NO	ROUTE	DESCRIPTION	LENGTH	WIDTH	4399000000-N TEMPORARY TRAFFIC CONTROL LS	4685000000-E		4686000000-E		4688000000-E		4695000000-E		4697000000-E		4705000000-E		4710000000-E		4721000000-E					4810000000-E		4900000000-N				
								4" X 90 M YELLOW THERMO LF	4" X 90 M WHITE THERMO LF	4" X 120 M WHITE THERMO LF	4" X 120 M YELLOW THERMO LF	6" X 90 M WHITE THERMO LF	8" X 90 M YELLOW THERMO LF	8" X 90 M WHITE THERMO LF	8" X 120 M WHITE THERMO LF	16" X 120 M WHITE THERMO LF	24" X 120 M WHITE THERMO LF	THERMO MSG ONLY 120 M EA	THERMO MSG SCHOOL 120 M EA	THERMO RXR 120 M EA	THERMO LT ARROW 90 M EA	THERMO RT ARROW 90 M EA	THERMO STR ARROW 90 M EA	THERMO STR & RT ARROW 90 M EA	MERGE ARROW EA	4" YELLOW PAINT LF	4" WHITE PAINT LF	YELLOW & YELLOW MARKERS EA	CRYSTAL & RED MARKERS EA				
10CR.10601.66	Mecklenburg	1	GRAHAM STREET (US 29)	FROM RR BRIDGE DECK TO MINT STREET	1.08	43.5	*	900		4,800	11,500	150	150		5,100		450	4			29	4	4				11,500	4,800	125	120			
TOTAL FOR PROJ NO. 10CR.10601.66								1.08		900		4,800	11,500	150	150	5,100		450	4			29	4	4				11,500	4,800	125	120		
										900		16,300			150	5,100		450	4			29	4	4				16,300		245			
10CR.10601.67	Mecklenburg	2	S. TRYON ST (NC 49)	FROM REMOUNT RD TO MOREHEAD STREET (SR 3815)	1.55	48.5	*			6,100	16,000	100		200	4,800		300	8				11					16,000	6,100	200	420			
TOTAL FOR PROJ NO. 10CR.10601.67								1.55				6,100	16,000	100		200	4,800		300	8					11				16,000	6,100	200	420	
												22,100			200	4,800		300	8				11				16,000	6,100	200	420			
															200	4,800		300	8				11				16,000	6,100	200	420			
10CR.10601.68	Mecklenburg	3	S. TRYON STREET (NC 49)	FROM I-77 TO REMOUNT RD	1.89	55	*			7,000	7,700			6,200	2,100		225										7,700	6,100	190	500			
TOTAL FOR PROJ NO. 10CR.10601.68								1.89				7,000	7,700			6,200	2,100		225										7,700	6,100	190	500	
												14,700			6,200	2,100		225									7,700	6,100	190	500			
															6,200	2,100		225									7,700	6,100	190	500			
															6,200	2,100		225									7,700	6,100	190	500			
10CR.10601.69	Mecklenburg	4	WEST BLVD (NC 160)	FROM I-77 TO S. TRYON ST (NC 49)	0.69	49	*	1,300		3,100	7,300		30		1,200		100										7,300	3,100	90	200			
TOTAL FOR PROJ NO. 10CR.10601.69								0.69		1,300		3,100	7,300		30		1,200		100											7,300	3,100	90	200
										1,300		10,400		30		1,200		100									7,300	3,100	90	200			
										1,300		10,400		30		1,200		100										7,300	3,100	90	200		
										1,300		10,400		30		1,200		100										7,300	3,100	90	200		
10CR.10601.70	Mecklenburg	5	WEST BLVD (NC 160)	FROM BILLY GRAHAM PKWY (SR 5901) TO PVT JT AT THE LIMITS OF THE AIRPORT PROJECT	1.9	48	*	500	14,650	18,500	6,500			500			120					27	18	9					200	200			
TOTAL FOR PROJ NO. 10CR.10601.70								1.9		500	14,650	18,500	6,500		500			120								27	18	9				200	200
										500	14,650	18,500	6,500		500			120						27	18	9				200	200		
										500	14,650	18,500	6,500		500			120							27	18	9				200	200	
										500	14,650	18,500	6,500		500			120							27	18	9				200	200	
										500	14,650	18,500	6,500		500			120							27	18	9				200	200	
										500	14,650	18,500	6,500		500			120							27	18	9				200	200	
										500	14,650	18,500	6,500		500			120							27	18	9				200	200	
										500	14,650	18,500	6,500		500			120							27	18	9				200	200	
										500	14,650	18,500	6,500		500			120							27	18	9				200	200	
										500	14,650	18,500	6,500		500			120							27	18	9				200	200	
										500	14,650	18,500	6,500		500			120							27	18	9				200	200	
										500	14,650	18,500	6,500		500			120							27	18	9				200	200	
										500	14,650	18,500	6,500		500			120							27	18	9				200	200	
										500	14,650	18,500	6,500		500			120							27	18	9				200	200	
										500	14,650	18,500	6,500		500			120							27	18	9				200	200	
										500	14,650	18,500	6,500		500			120							27	18	9				200	200	
										500	14,650	18,500	6,500		500			120							27	18	9				200	200	
										500	14,650	18,500	6,500		500			120							27	18	9				200	200	
										500	14,650	18,500	6,500		500			120							27	18	9				200	200	
										500	14,650	18,500	6,500		500			120							27	18	9				200	200	
										500	14,650	18,500	6,500		500			120							27	18	9				200	200	
										500	14,650	18,500	6,500		500			120							27	18	9				200	200	
										500	14,650	18,500	6,500		500			120							27	18	9				200	200	
										500	14,650	18,500	6,500		500			120							27	18	9				200	200	
										500	14,650	18,500	6,500		500			120							27	18	9				200	200	
										500	14,650	18,500	6,500		500			120							27	18	9				200	200	
										500	14,650	18,500	6,500		500			120							27	18	9				200	200	
										500	14,650	18,500	6,500		500			120							27	18	9				200	200	
										500	14,650	18,500	6,500		500			120							27	18	9				200	200	
										500	14,650	18,500	6,500		500			120							27	18	9				200	200	
										500	14,650	18,500	6,500		500			120							27	18	9				200	200	
										500	14,650	18,500	6,500		500			120							27	18	9				200	200	
										500	14,650	18,500	6,500		500			120							27	18	9				200	200	
										500	14,650	18,500	6,500		500			120							27	18	9				200	200	
										500	14,650	18,500	6,500		500			120							27	18	9				200	200	
										500	14,650	18,500	6,500		500			120							27	18	9				200	200	
										500	14,650	18,500	6,500		500			120							27	18	9				200	200	
										500	14,650	18,500	6,500		500			120							27	18	9				200	200	
										500	14,650	18,500	6,500		500			120							27	18	9				200	200	
										500	14,650	18,500	6,500		500			120							27	18	9				200	200	

PROJECT REFERENCE NO.	SHEET NO.
10CR.10601.66, ETC	16

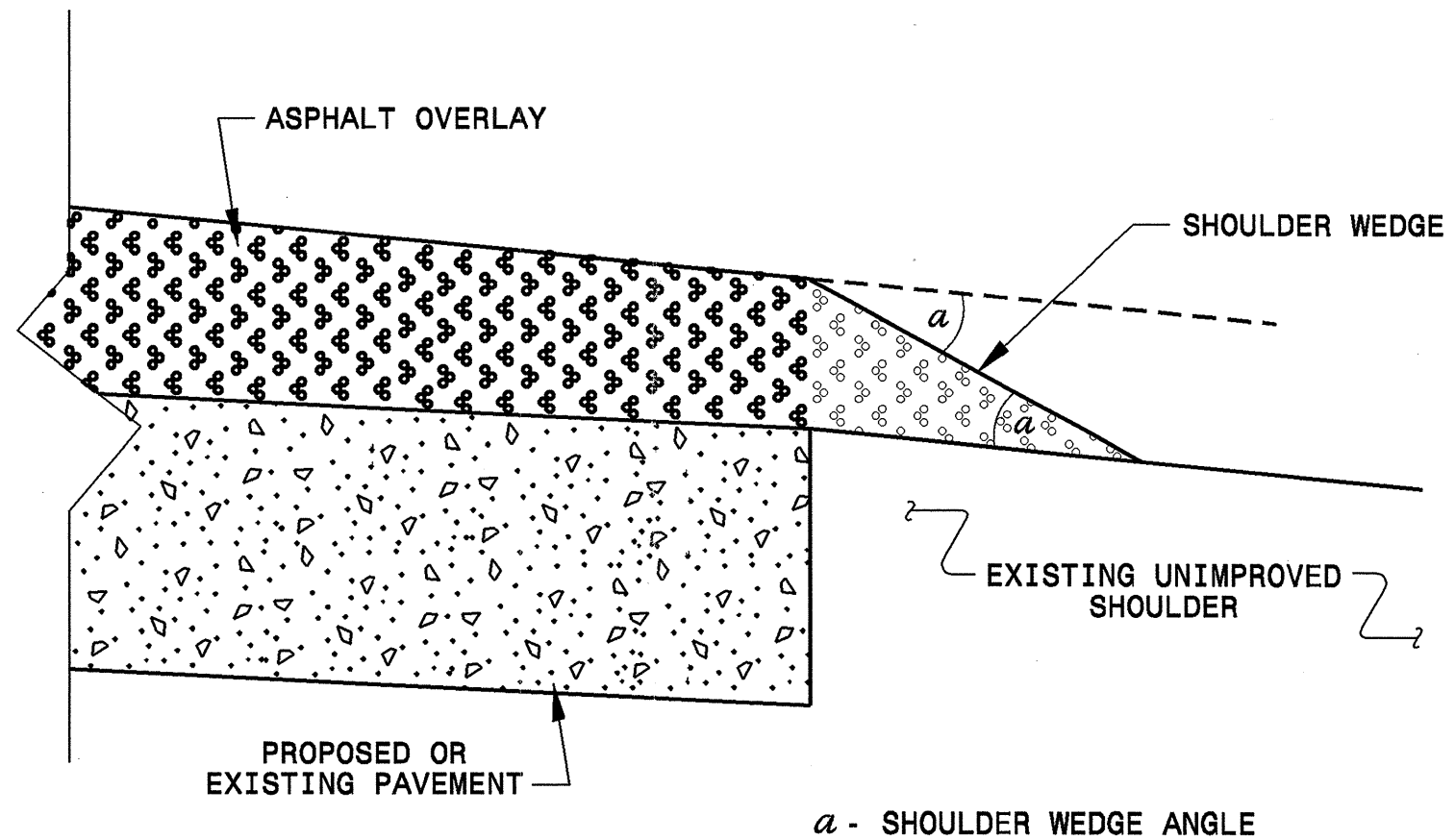

## SHOULDER WEDGE DETAIL

27-FEB-2012 14:31  
 C:\misc\shoulder\std\stand\shoulderwedgedetail.dgn  
 P:\porter\AT\_CSD237485

<b>CONTRACT STANDARDS AND DEVELOPMENT UNIT</b> Office 919-707-6950 FAX 919-250-4119			
<b>SHOULDER WEDGE DETAIL</b>			
ORIGINAL BY:	T. SPELL	DATE:	7-19-11
MODIFIED BY:		DATE:	
CHECKED BY:		DATE:	
FILE SPEC.:	s:\user\details\stand\shoulderwedgedetail.dgn		



NOTES: Less than 5' - 10' undisturbed buffer from ROW, ditchline, water feature, or drainage inlet, add BMP.

BMP Options: Wattle or Silt Fence

# EROSION CONTROL DETAIL

PROJECT REFERENCE NO. 10CRJ0601.66, ETC	SHEET NO. EC-1
--	-------------------

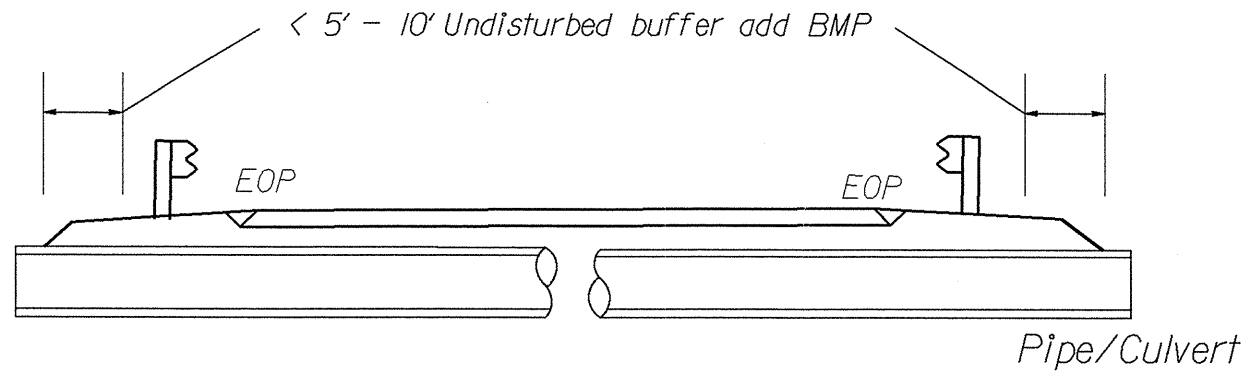

< 5' - 10' Undisturbed buffer from jurisdictional feature add BMP

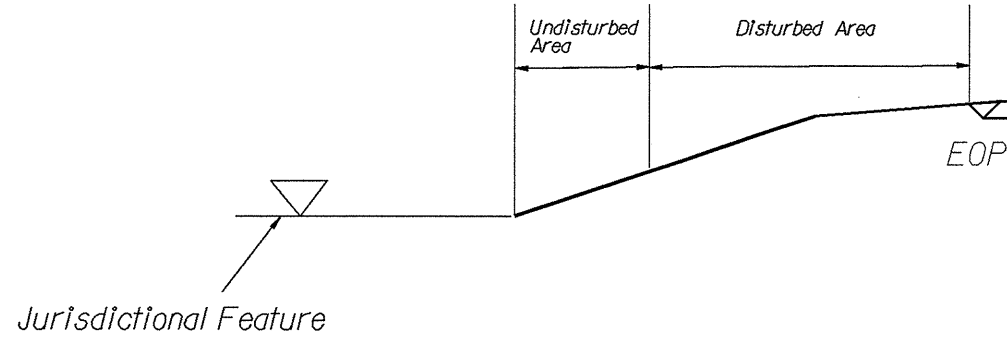

< 5' - 10' Undisturbed buffer from ditchline, add BMP

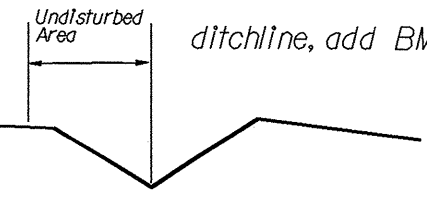

Use BMP's if shoulders and/or frontslopes and/or ditchline and/or backslopes are disturbed

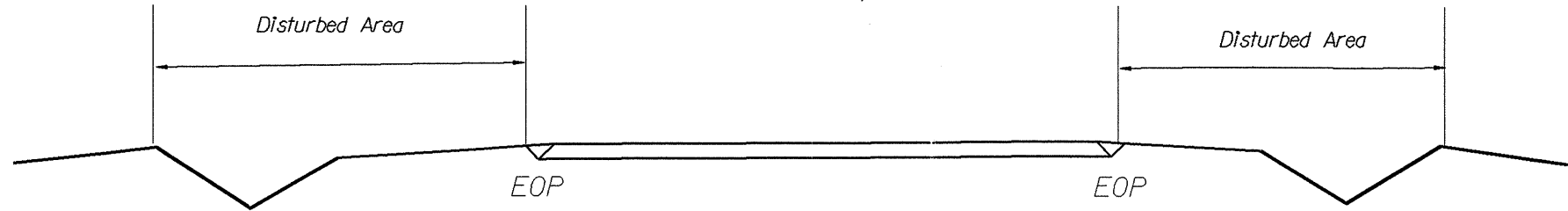

< 5' - 10' Undisturbed buffer from inlet, add wattle

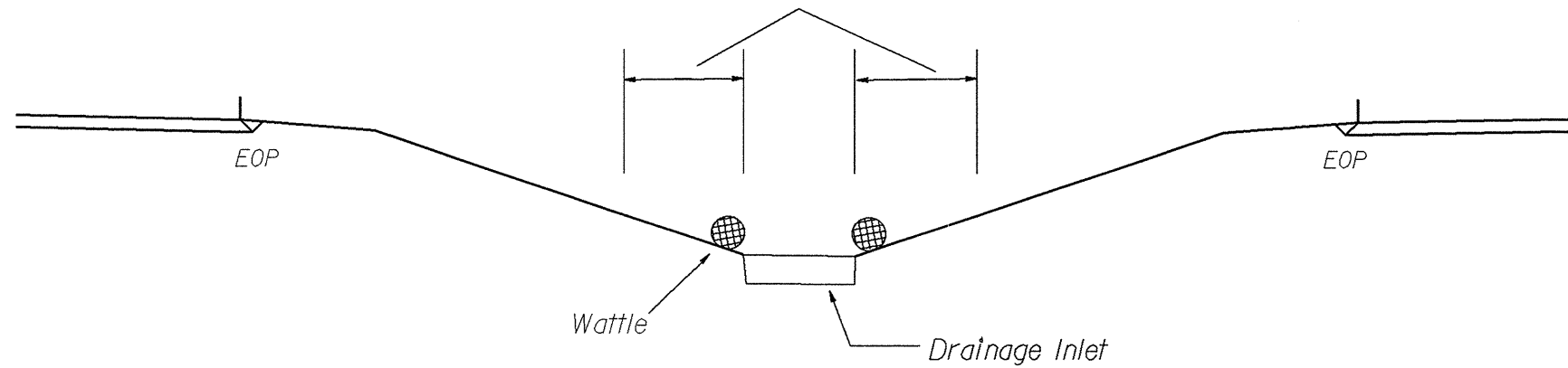

NOT TO SCALE

# WATTLE WITH POLYACRYLAMIDE (PAM) DETAIL

**NOTES:**

- USE MINIMUM 12 IN. DIAMETER EXCELSIOR WATTLE.
- USE 2 FT. WOODEN STAKES WITH A 2 IN. BY 2 IN. NOMINAL CROSS SECTION.
- ONLY INSTALL WATTLE(S) TO A HEIGHT IN DITCH SO FLOW WILL NOT WASH AROUND WATTLE AND SCOUR DITCH SLOPES AND AS DIRECTED.
- INSTALL A MINIMUM OF 2 UPSLOPE STAKES AND 4 DOWNSLOPE STAKES AT AN ANGLE TO WEDGE WATTLE TO BOTTOM OF DITCH.
- PROVIDE STAPLES MADE OF 0.125 IN. DIAMETER STEEL WIRE FORMED INTO A U SHAPE NOT LESS THAN 12" IN LENGTH.
- INSTALL STAPLES APPROXIMATELY EVERY 1 LINEAR FOOT ON BOTH SIDES OF WATTLE AND AT EACH END TO SECURE IT TO THE SOIL.
- INSTALL MATTING IN ACCORDANCE WITH SECTION 1631 OF THE STANDARD SPECIFICATIONS.
- PRIOR TO POLYACRYLAMIDE (PAM) APPLICATION, OBTAIN A SOIL SAMPLE FROM PROJECT LOCATION, AND FROM OFFSITE MATERIAL, AND ANALYZE FOR APPROPRIATE PAM FLOCCULANT TO BE APPLIED TO EACH WATTLE.
- INITIALLY APPLY 2 OUNCES OF ANIONIC OR NEUTRALLY CHARGED PAM OVER WATTLE WHERE WATER WILL FLOW AND 1 OUNCE OF PAM ON MATTING ON EACH SIDE OF WATTLE. REAPPLY PAM AFTER EVERY RAINFALL EVENT THAT IS EQUAL TO OR EXCEEDS 0.50 IN.

