

07-NOV-2011 14:37
 R:\TIP\Projects\247799
 br-rashid

T.I.P.: R-3825A

CONTRACT: C202786

**STATE OF NORTH CAROLINA
 DEPARTMENT OF TRANSPORTATION**

**PAVEMENT MARKING PLAN
 JOHNSTON COUNTY**

**LOCATION: NC 42 FROM US 70 IN CLAYTON TO 0.31 MI
 EAST OF SR 1902 (GLEN LAUREL RD)**

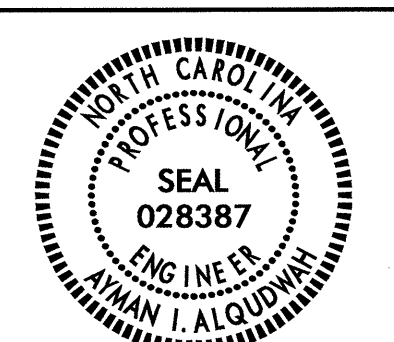
TIP NO. R-3825A	SHEET NO. PMP-1
APPROVED: <i>Alman Alqudwah</i>	
DATE: 11-14-11	
SEAL	
	

**R-3825A FINAL PAVEMENT
 MARKING SCHEDULE**

SYMBOL	DESCRIPTION
	(FINAL PAVEMENT MARKINGS)
	THERMOPLASTIC (16", 120 MILS)
T1	WHITE LINE, RRX
	THERMOPLASTIC (24", 120 MILS)
T2	WHITE STOPBAR
	THERMOPLASTIC (4", 120 MILS)
T8	2 FT.-6 FT./SP WHITE MINISKIP
T9	2 FT.-6 FT./SP YELLOW MINISKIP
TC	10 FT. WHITE SKIP
TD	3 FT.-9 FT./WHITE MINISKIP
TE	WHITE SOLID LANE LINE
TI	YELLOW DOUBLE CENTER
	THERMOPLASTIC (4", 90 MILS)
TA	WHITE EDGELINE
TB	YELLOW EDGELINE
	THERMOPLASTIC (8", 90 MILS)
TN	WHITE GORELINE
TO	WHITE DIAGONAL
TP	YELLOW DIAGONAL
	THERMOPLASTIC (8", 120 MILS)
TR	WHITE SOLID LANE LINE
	THERMOPLASTIC PAVEMENT MARKING CHARACTER (120 MILS)
UI	ALPHANUMERIC CHAR.
	THERMOPLASTIC PAVEMENT MARKING SYMBOLS (90 MILS)
UA	LEFT TURN ARROW
UB	RIGHT TURN ARROW
UC	STRAIGHT ARROW
UD	COMBO.STRAIGHT/LEFT ARROW
UE	STRAIGHT/RIGHT ARROW
UF	COMBO.LEFT/RIGHT ARROW
UN	24" YIELD LINE TRIANGLE
UP	MERGE ARROW
UT	U-TURN ARROW
	(MARKERS)
	PERMANENT RAISED PAVEMENT MARKERS
MA	YELLOW & YELLOW
MB	CRYSTAL & RED

ROADWAY STANDARD DRAWING

THE FOLLOWING ROADWAY STANDARDS AS APPEAR IN "ROADWAY STANDARD DRAWINGS" - PROJECT SERVICES UNIT - N.C. DEPARTMENT OF TRANSPORTATION - RALEIGH, N.C., DATED JANUARY 2012 ARE APPLICABLE TO THIS PROJECT AND BY REFERENCE HEREBY ARE CONSIDERED A PART OF THESE PLANS:

STD. NO.	TITLE
1205.01	PAVEMENT MARKINGS - LINE TYPES AND OFFSETS
1205.02	PAVEMENT MARKINGS - 2 LANE AND MULTILANE ROADWAYS
1205.04	PAVEMENT MARKINGS - INTERSECTIONS
1205.05	PAVEMENT MARKINGS - TURN LANES
1205.06	PAVEMENT MARKINGS - THRU LANE DROPS
1205.08	PAVEMENT MARKINGS - SYMBOL AND WORD MESSAGES
1205.09	PAVEMENT MARKINGS - PAINTED ISLANDS
1205.11	PAVEMENT MARKINGS - RAILROAD CROSSINGS
1250.01	PAVEMENT MARKER SPACING
1251.01	RAISED PAVEMENT MARKERS - TEMPORARY AND PERMANENT
1261.01	GUARDRAIL AND BARRIER DELINEATOR SPACING
1261.02	GUARDRAIL AND BARRIER DELINEATOR TYPES
1262.01	GUARDRAIL END DELINEATION

GENERAL NOTES

THE FOLLOWING GENERAL NOTES APPLY AT ALL TIMES FOR THE DURATION OF THE CONSTRUCTION PROJECT, EXCEPT WHEN OTHERWISE NOTED IN THE PLAN, OR DIRECTED BY THE ENGINEER.

- A) INSTALL PAVEMENT MARKINGS AND PAVEMENT MARKERS ON THE FINAL SURFACE AS FOLLOWS:

ROAD NAME	MARKING	MARKER
-L-, -Y1-, -Y2-, -Y3- & -DR-	THERMOPLASTIC	PERMANENT RAISED MARKER
- B) TIE PROPOSED PAVEMENT MARKING LINES TO EXISTING PAVEMENT MARKING LINES.
- C) REMOVE/REPLACE ANY CONFLICTING/DAMAGED PAVEMENT MARKINGS AND MARKERS.
- D) PASSING ZONES WILL BE DETERMINED IN THE FIELD AND MUST BE APPROVED BY THE ENGINEER.
- E) STOPBAR LOCATION AT NON-SIGNALIZED INTERSECTIONS MAY BE ADJUSTED AS DIRECTED BY THE ENGINEER.
- F) MARKERS SHALL BE INSTALLED ACCORDING TO THE NCDOT ROADWAY STANDARD DRAWING 1250.01.

INDEX

SHEET NO.	DESCRIPTION
PMP-1	PAVEMENT MARKING PLAN TITLE AND SCHEDULE SHEET
PMP-2-8	PAVEMENT MARKING DETAIL

PLAN PREPARED BY: N.C.D.O.T. SIGNING AND DELINEATION UNIT

AYMAN ALQUDWAH, PE, CPM SIGNING & DELINEATION REGIONAL ENGINEER

BASIR A. RASHID SIGNING & DELINEATION PROJECT DESIGN ENGINEER

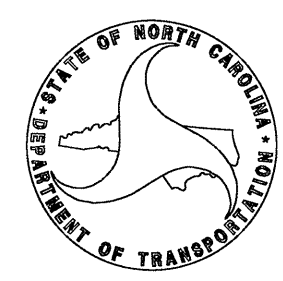

TIP NO. R-3825A	SHEET NO. PMP-2
APPROVED: <i>[Signature]</i>	
DATE: 11-14-11	
SEAL	

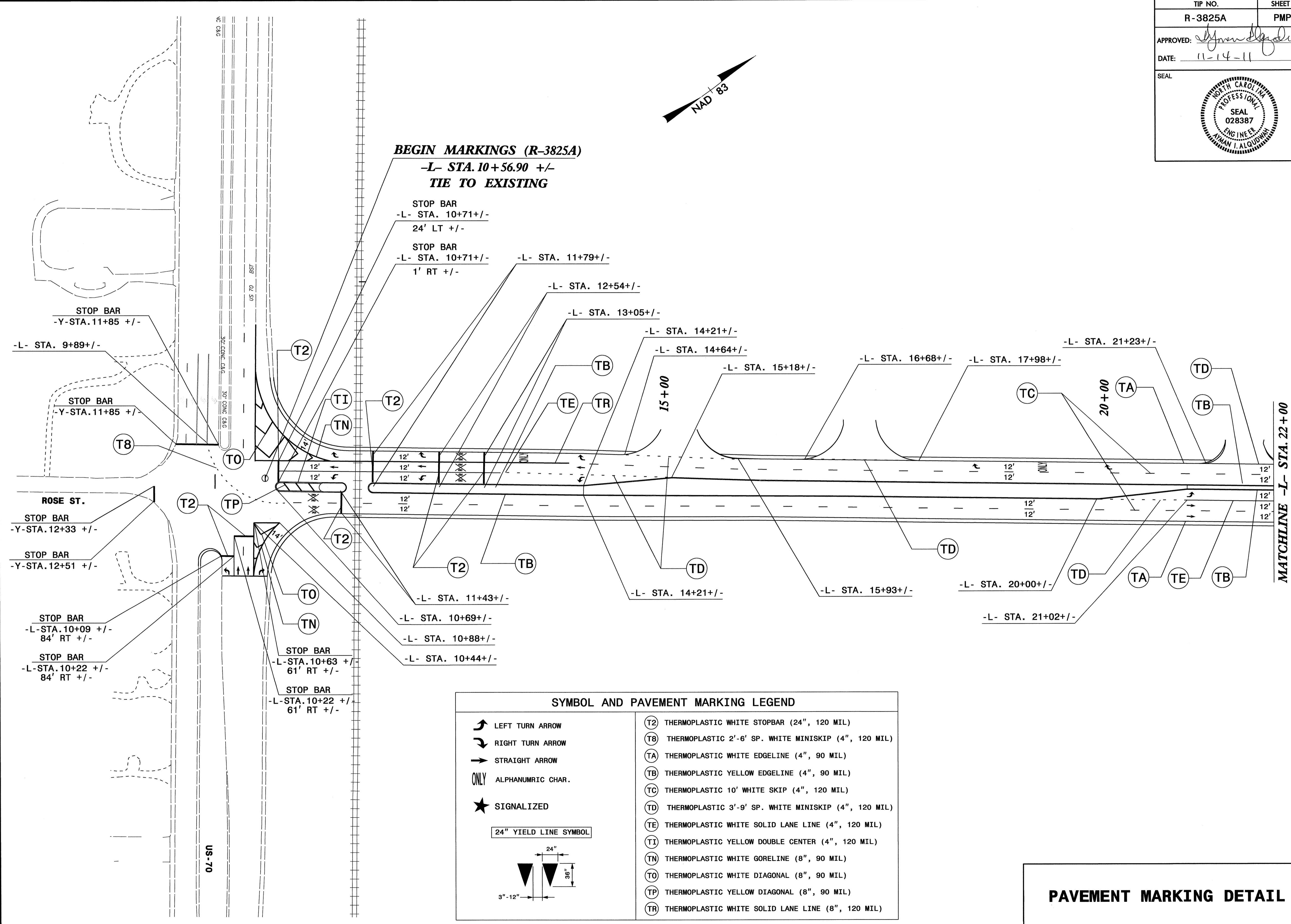
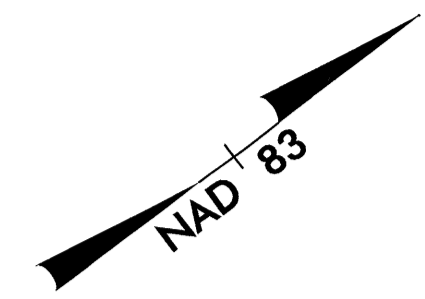

BEGIN MARKINGS (R-3825A)

**-L- STA. 10+56.90 +/-
TIE TO EXISTING**

STOP BAR
-L- STA. 10+71 +/-
24' LT +/-

STOP BAR
-L- STA. 10+71 +/-
1' RT +/-

-L- STA. 11+79 +/-

-L- STA. 12+54 +/-

-L- STA. 13+05 +/-

-L- STA. 14+21 +/-

-L- STA. 14+64 +/-

-L- STA. 15+18 +/-

-L- STA. 16+68 +/-

-L- STA. 17+98 +/-

-L- STA. 21+23 +/-

STOP BAR
-Y- STA. 11+85 +/-

STOP BAR
-Y- STA. 11+85 +/-

ROSE ST.
STOP BAR
-Y- STA. 12+33 +/-

STOP BAR
-Y- STA. 12+51 +/-

STOP BAR
-L- STA. 10+09 +/-
84' RT +/-

STOP BAR
-L- STA. 10+22 +/-
84' RT +/-

STOP BAR
-L- STA. 10+63 +/-
61' RT +/-

STOP BAR
-L- STA. 10+22 +/-
61' RT +/-

-L- STA. 11+43 +/-

-L- STA. 10+69 +/-

-L- STA. 10+88 +/-

-L- STA. 10+44 +/-

-L- STA. 14+21 +/-

-L- STA. 15+93 +/-

-L- STA. 20+00 +/-

-L- STA. 21+02 +/-

MATCHLINE -L- STA. 22+00
SEE SHEET PMP-3

SYMBOL AND PAVEMENT MARKING LEGEND

- LEFT TURN ARROW
- RIGHT TURN ARROW
- STRAIGHT ARROW
- ONLY ALPHANUMRIC CHAR.
- SIGNALIZED

24" YIELD LINE SYMBOL

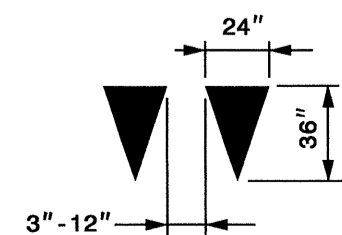

- (T2) THERMOPLASTIC WHITE STOPBAR (24", 120 MIL)
- (T8) THERMOPLASTIC 2'-6" SP. WHITE MINISKIP (4", 120 MIL)
- (TA) THERMOPLASTIC WHITE EDGELINE (4", 90 MIL)
- (TB) THERMOPLASTIC YELLOW EDGELINE (4", 90 MIL)
- (TC) THERMOPLASTIC 10' WHITE SKIP (4", 120 MIL)
- (TD) THERMOPLASTIC 3'-9" SP. WHITE MINISKIP (4", 120 MIL)
- (TE) THERMOPLASTIC WHITE SOLID LANE LINE (4", 120 MIL)
- (TI) THERMOPLASTIC YELLOW DOUBLE CENTER (4", 120 MIL)
- (TN) THERMOPLASTIC WHITE GORELINE (8", 90 MIL)
- (TO) THERMOPLASTIC WHITE DIAGONAL (8", 90 MIL)
- (TP) THERMOPLASTIC YELLOW DIAGONAL (8", 90 MIL)
- (TR) THERMOPLASTIC WHITE SOLID LANE LINE (8", 120 MIL)

PAVEMENT MARKING DETAIL

I:\NOV-2011\11445
 p:\pmp\01615\B\3825A_Sgn_pmp_Sheet-2.dgn
 AT 11/14/11 11:24:39 AM
 brashid

TIP NO. R-3825A	SHEET NO. PMP-3
APPROVED: <i>[Signature]</i>	
DATE: 11-14-11	



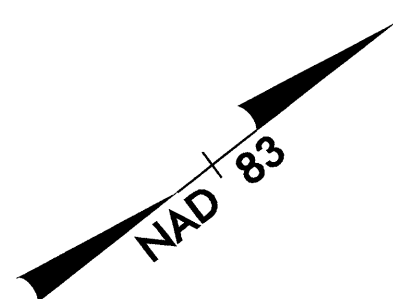
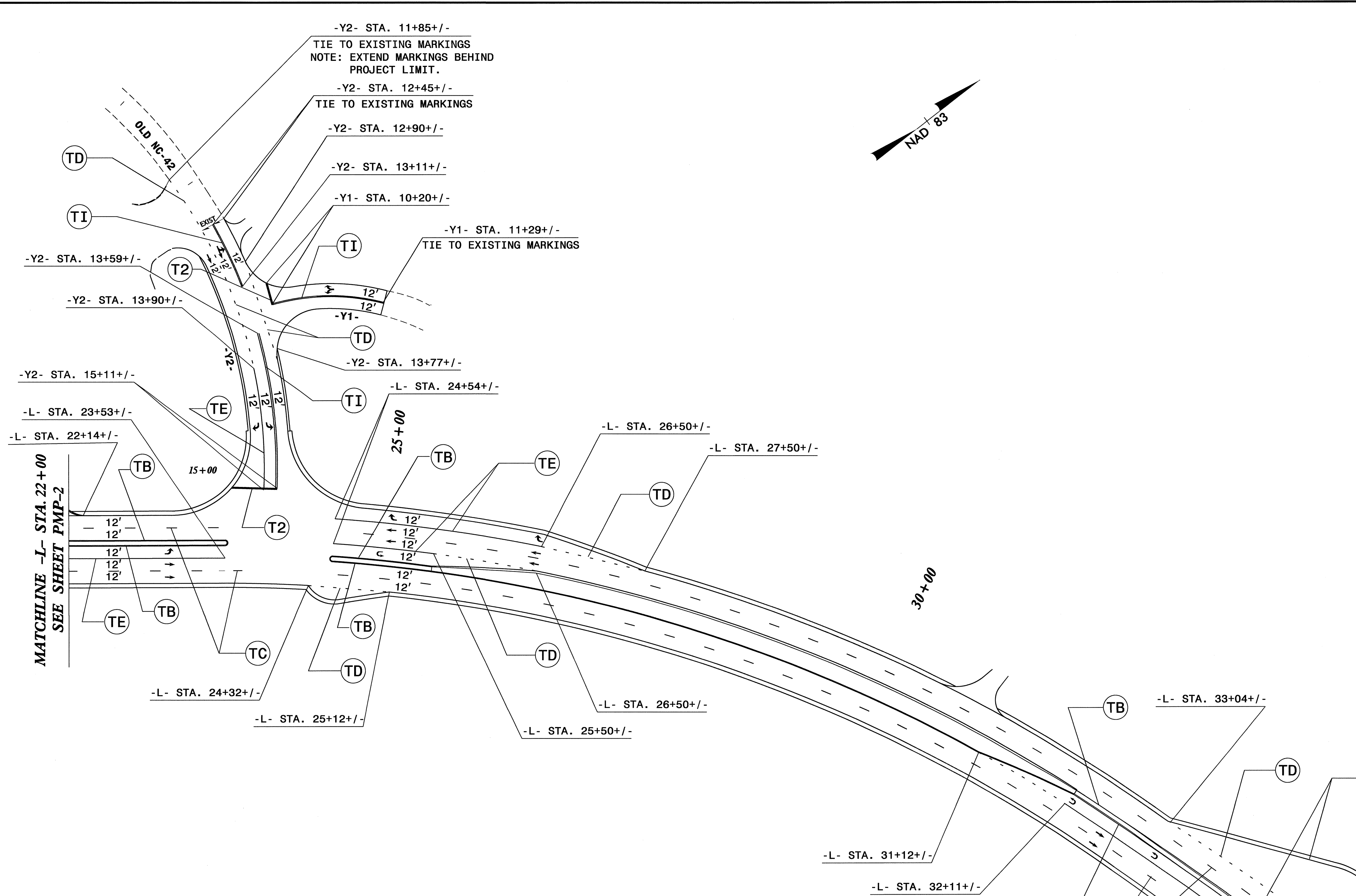

SYMBOL AND PAVEMENT MARKING LEGEND			
	LEFT TURN ARROW		THERMOPLASTIC WHITE STOPBAR (24", 120 MIL)
	RIGHT TURN ARROW		THERMOPLASTIC WHITE EDGELINE (4", 90 MIL)
	STRAIGHT ARROW		THERMOPLASTIC YELLOW EDGELINE (4", 90 MIL)
	COMBINATION STRAIGHT/LEFT ARROW		THERMOPLASTIC 10' WHITE SKIP (4", 120 MIL)
	COMBINATION LEFT/RIGHT ARROW		THERMOPLASTIC 3'-9' SP. WHITE MINISKIP (4", 120 MIL)
	U TURN ARROW		THERMOPLASTIC WHITE SOLID LANE LINE (4", 120 MIL)
			THERMOPLASTIC YELLOW DOUBLE CENTER (4", 120 MIL)

PAVEMENT MARKING DETAIL

07-NOV-2011 14:23
P:\TIP\Projects-RAR\3825a\Traffic\Signing\CADD\PMR\3825A_Sgn_pmp_Sheet-3.dgn
brashid AT 12/27/11

TIP NO. R-3825A	SHEET NO. PMP-4
APPROVED: <i>[Signature]</i>	
DATE: 11-14-11	
SEAL	

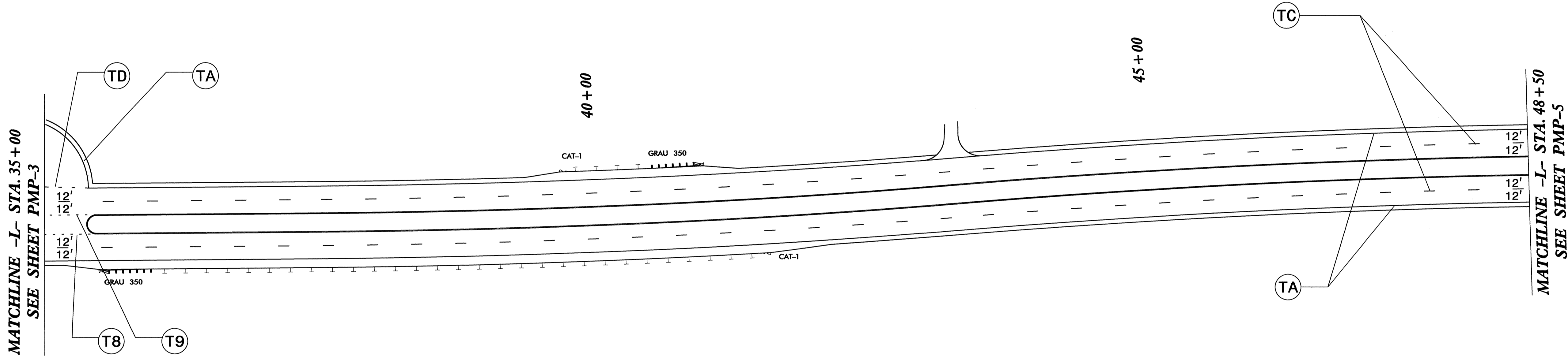

PAVEMENT MARKING LEGEND	
(TA)	THERMOPLASTIC WHITE EDGELINE (4", 90 MIL)
(TC)	THERMOPLASTIC 10' WHITE SKIP (4", 120 MIL)
(T8)	THERMOPLASTIC 2 FT.-6 FT./SP WHITE MINISKIP (4", 120MIL)
(T9)	THERMOPLASTIC 2 FT.-6 FT./SP YELLOW MINISKIP (4", 120MIL)

PAVEMENT MARKING DETAIL

07-NOV-2011 14:24
 P:\TIPR-01\11-R-3825A\Traffic\Signing\CADD\NMP\R3825A_Sgn_pmp_Sheet-4.dgn
 brashid

TIP NO. R-3825A	SHEET NO. PMP-5
APPROVED: <i>[Signature]</i>	
DATE: 11/14/11	
SEAL	

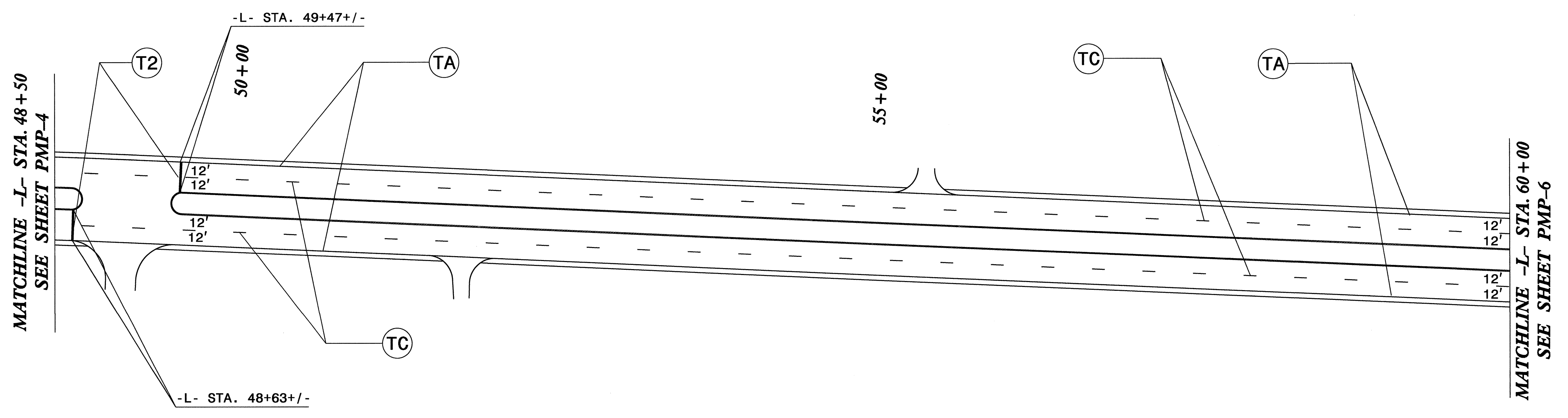
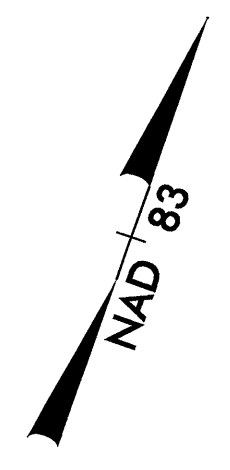

PAVEMENT MARKING LEGEND	
(T2)	THERMOPLASTIC WHITE STOPBAR (24", 120 MIL)
(TA)	THERMOPLASTIC WHITE EDGELINE (4", 90 MIL)
(TC)	THERMOPLASTIC 10' WHITE SKIP (4", 120 MIL)

PAVEMENT MARKING DETAIL

07-NOV-2011 14:25
 P:\TIP\Projects\R3825a\Traffic\Signing\CADD\PMR3825A_Sgn_pmp_Sheet-5.dgn
 brashid AT 11/24/11

SYMBOL AND PAVEMENT MARKING LEGEND

	LEFT TURN ARROW	(T2)	THERMOPLASTIC WHITE STOPBAR (24", 120 MIL)
	RIGHT TURN ARROW	(T8)	THERMOPLASTIC 2 FT.-6 FT./SP WHITE MINISKIP (4", 120MIL)
	STRAIGHT ARROW	(T9)	THERMOPLASTIC 2 FT.-6 FT./SP YELLOW MINISKIP (4", 120MIL)
	ALPHANUMERIC CHAR.	(TA)	THERMOPLASTIC WHITE EDGELINE (4", 90 MIL)
	U-TURN ARROW	(TB)	THERMOPLASTIC YELLOW EDGELINE (4", 90 MIL)
	COMBO. STRAIGHT/RIGHT ARROW	(TC)	THERMOPLASTIC 10' WHITE SKIP (4", 120 MIL)
	SIGNALIZED	(TD)	THERMOPLASTIC 3'-9' SP. WHITE MINISKIP (4", 120 MIL)
		(TE)	THERMOPLASTIC WHITE SOLID LANE LINE (4", 120 MIL)
		(TI)	THERMOPLASTIC YELLOW DOUBLE CENTER (4", 120 MIL)
		(TP)	THERMOPLASTIC YELLOW DIAGONAL (8", 90 MIL)

TIP NO.	SHEET NO.
R-3825A	PMP-7
APPROVED:	
DATE: 11-14-11	
SEAL	

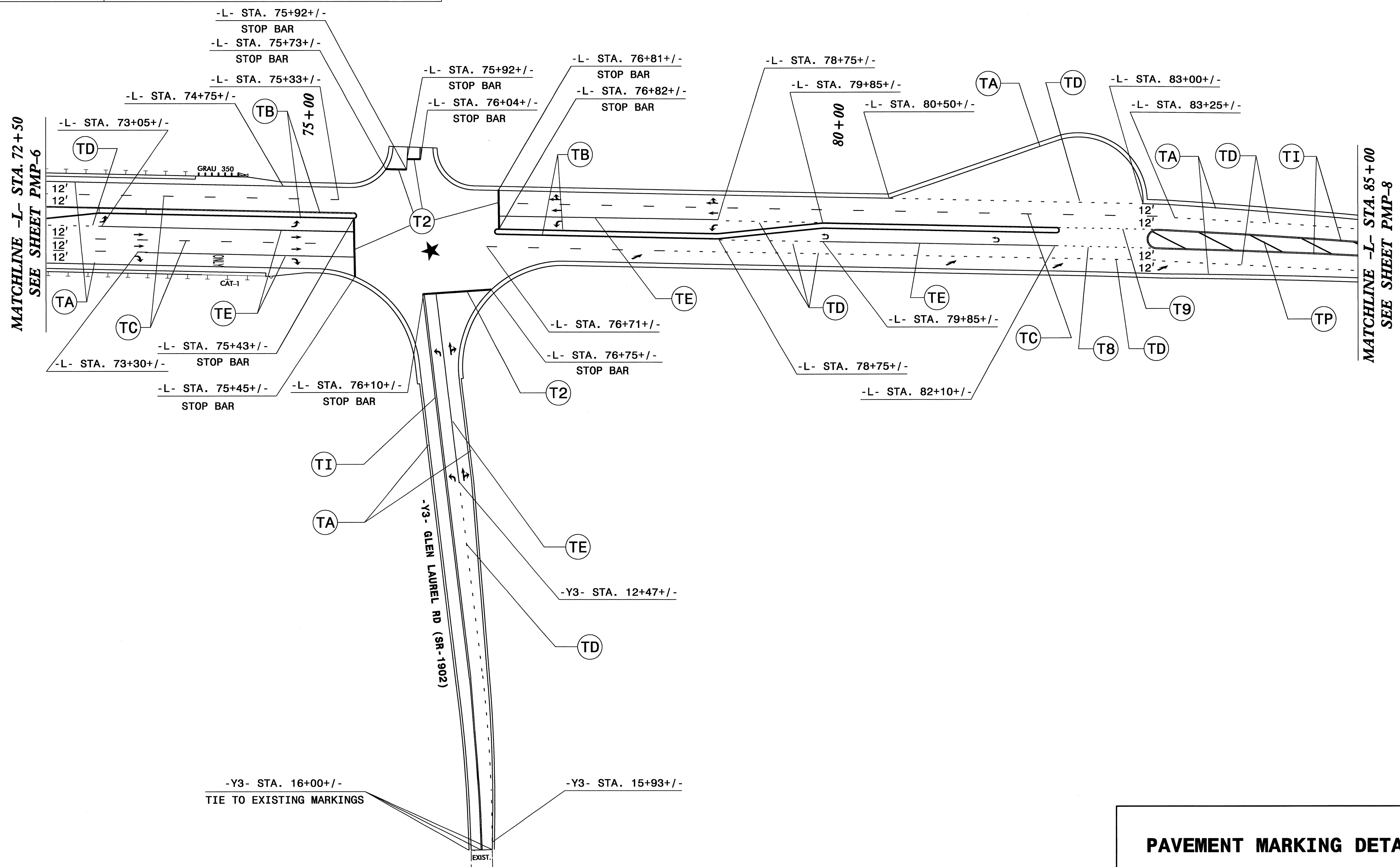
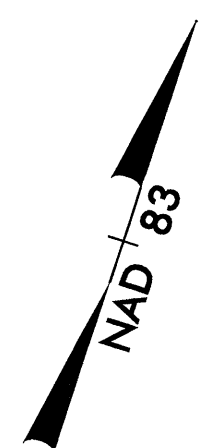

PAVEMENT MARKING DETAIL

07.NOV.2011 4:27 PM \\p01s01-rp3825a\Traffic\Signing\CADD\PMR\3825A_sign_pmp_Sheet-7.dgn
 P:\TIP\01s01-rp3825a\Traffic\Signing\CADD\PMR\3825A_sign_pmp_Sheet-7.dgn
 br_ashid

TIP NO.	SHEET NO.
R-3825A	PMP-8
APPROVED: <i>[Signature]</i>	
DATE: 11-14-11	
SEAL	

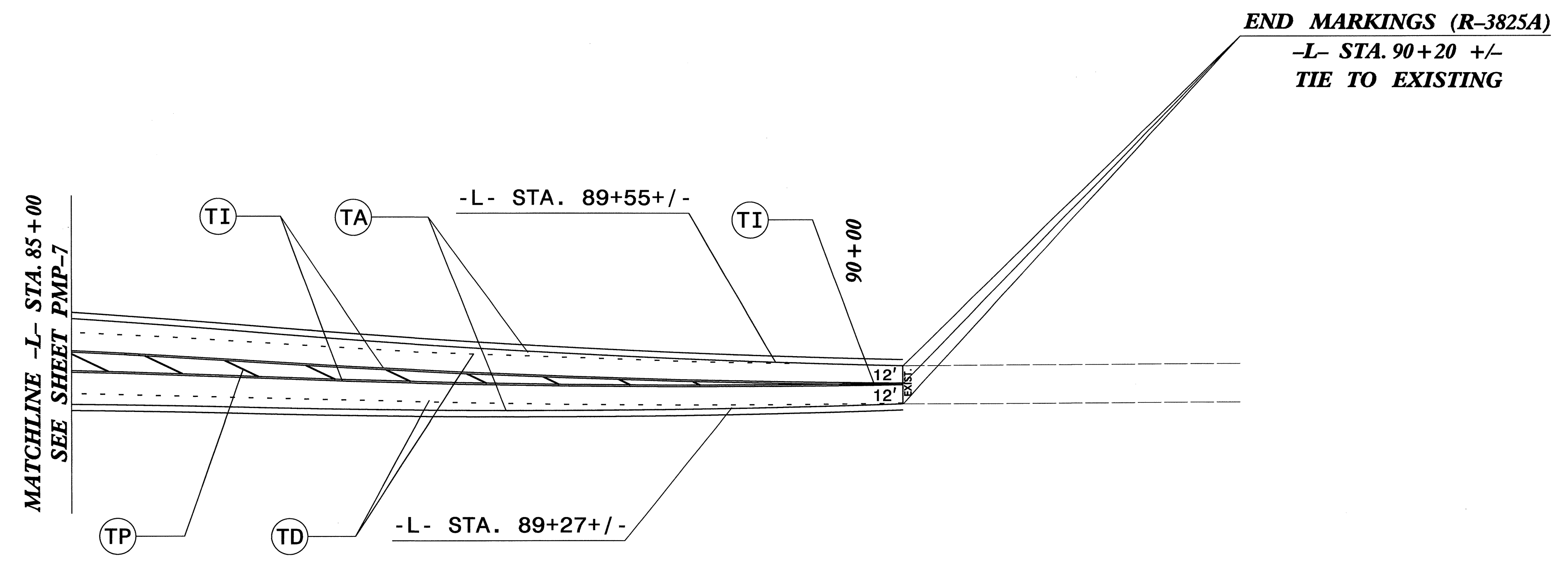
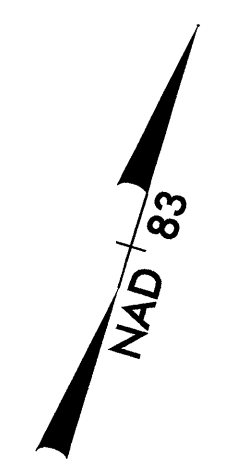

PAVEMENT MARKING LEGEND	
(TA)	THERMOPLASTIC WHITE EDGELINE (4", 90 MIL)
(TD)	THERMOPLASTIC 3'-9" SP. WHITE MINISKIP (4", 120 MIL)
(TI)	THERMOPLASTIC YELLOW DOUBLE CENTER (4", 120 MIL)
(TP)	THERMOPLASTIC YELLOW DIAGONAL (8", 90 MIL)

PAVEMENT MARKING DETAIL

07-NOV-2011 14:28
 C:\Users\pmp\Documents\Projects\3825A\Traffic\Signing\CADD\PMR\3825A_Sign_PMP-Sheet-8.dgn
 bpshtid AT 1E247798