

PROJECT: R-2413C

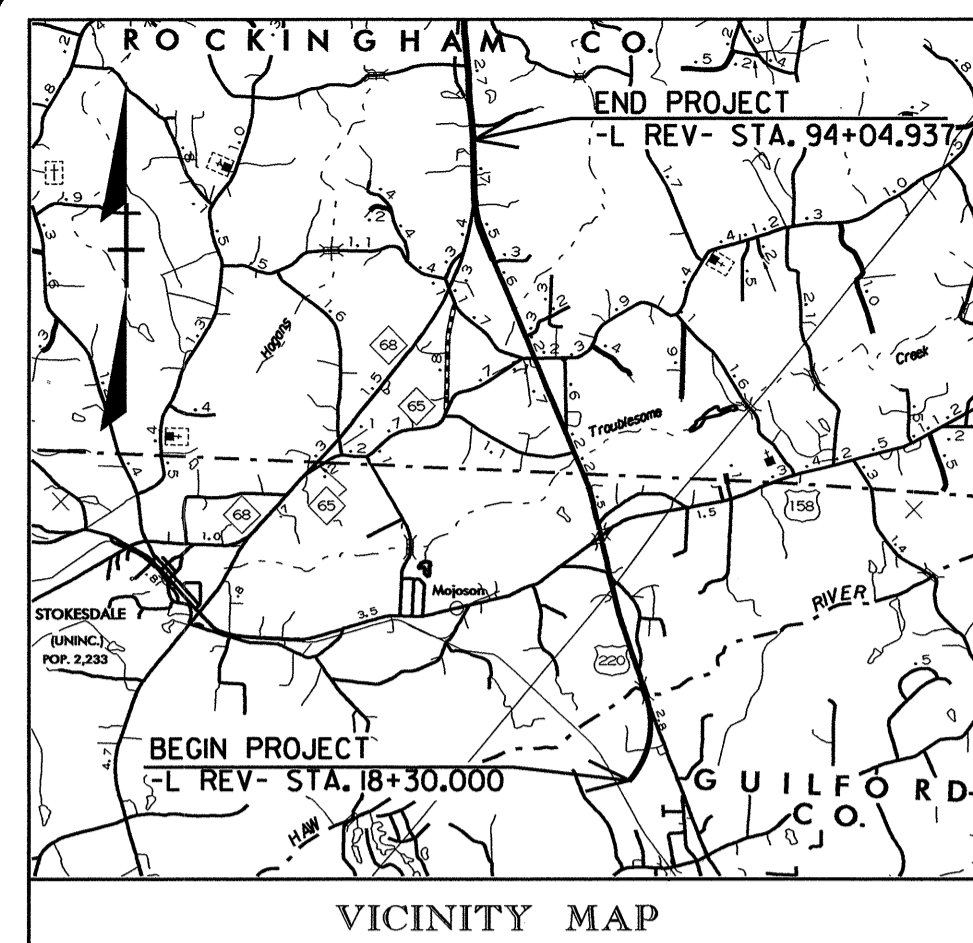

STATE OF NORTH CAROLINA DIVISION OF HIGHWAYS

GUILFORD AND ROCKINGHAM COUNTIES

STATE	STATE PROJECT REFERENCE NO.	SHEET NO.
N.C.	R-2413C	ITS-1
STATE PROJ. NO.	F.A. PROJ. NO.	DESCRIPTION
34429.1.3		PE
34429.3.7		CONST.

ITS PLANS

THIS PROJECT CONSISTS OF FURNISHING AND INSTALLING EQUIPMENT AND MATERIALS FOR THE INSTALLATION OF CCTV CAMERAS ALONG US 220 IN GUILFORD AND ROCKINGHAM COUNTIES, NORTH CAROLINA. RELATED MATERIALS CONSIST OF CCTV CAMERA EQUIPMENT, FIBER OPTIC COMMUNICATIONS CABLE, WOOD POLES, UNDERGROUND CONDUIT, JUNCTION BOXES, SPLICE ENCLOSURES, AND ELECTRICAL SERVICE EQUIPMENT.

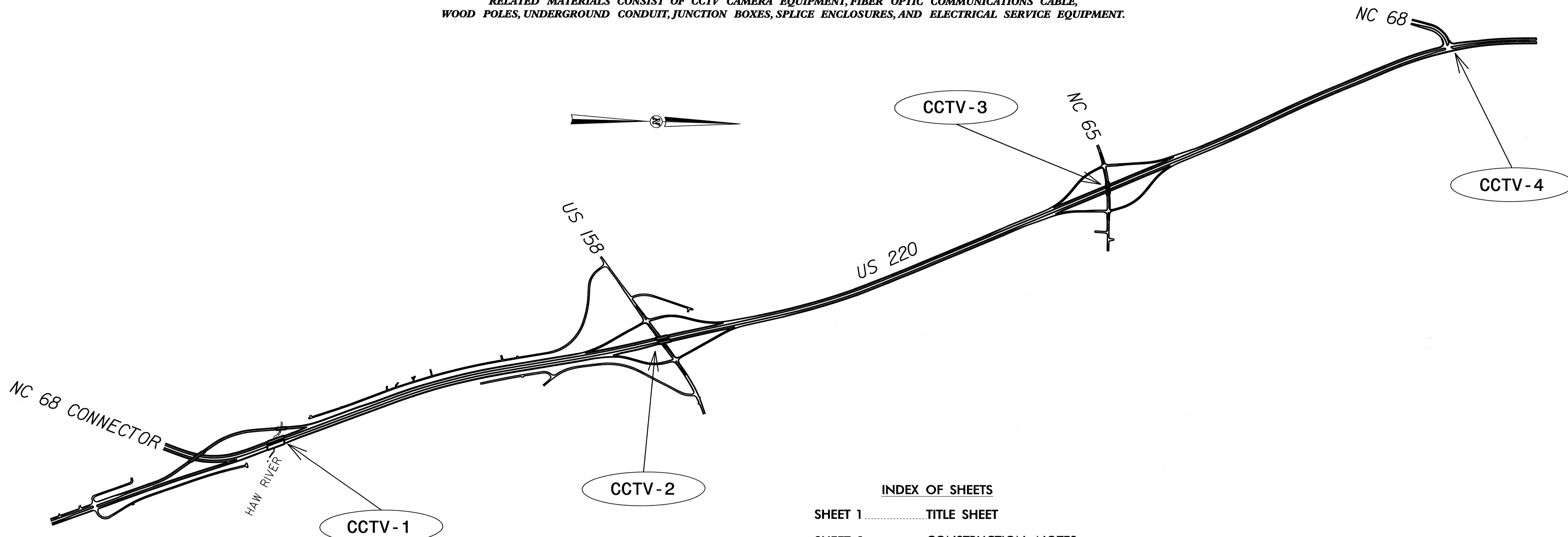

INDEX OF SHEETS

- SHEET 1 TITLE SHEET
- SHEET 2 CONSTRUCTION NOTES
- SHEET 2A-2B TYPICAL DETAILS
- SHEET 3 SUMMARY OF QUANTITIES
- SHEET 4 - 13 PLAN OVERVIEW
- SHEET 14 - 16 SPLICE DETAILS

LEGEND

- | | | | |
|-----------|---------------------------------|---|-----------------------------|
| ----- | NEW CONDUIT | Ⓢ | NEW SPLICE ENCLOSURE |
| - - - - - | EXISTING CONDUIT | ⊠ | NEW CCTV CAMERA ASSEMBLY |
| - - - - - | NEW DIRECTIONAL DRILLED CONDUIT | ⚡ | NEW ELECTRICAL SERVICE |
| | NEW GUARDRAIL | ⚡ | EXISTING ELECTRICAL SERVICE |
| - - - - - | EXISTING GUARDRAIL | □ | NEW 6" X 6" WOOD PEDESTAL |
| □ | NEW JUNCTION BOX | | |
| ○ | NEW WOOD POLE | | |
| ● | EXISTING WOOD POLE | | |

2006 STANDARD SPECIFICATION

**NCDOT CONTACT:
TRANSPORTATION MOBILITY AND SAFETY**

G.A. FULLER, P.E.
STATE ITS & SIGNALS ENGINEER

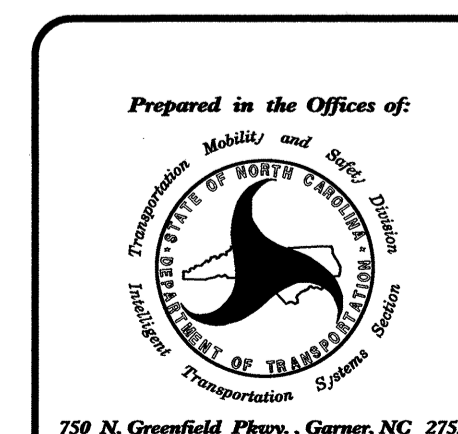

ENGLISH

ALL DIMENSIONS IN THESE PLANS ARE IN FEET UNLESS OTHERWISE NOTED

SEAL

PROFESSIONAL ENGINEER
SEAL
023919
GREGORY A. FULLER

Gregory A. Fuller
10/5/11

- 1 MVD CONTROL CABLES
- 2 3-WIRE #3 SERVICE ENTRANCE CONDUCTORS
- 3A 4-WIRE #4 COPPER FEEDER CONDUCTORS
- 3B 4-WIRE #6 COPPER FEEDER CONDUCTORS
- 3C 3-WIRE #8 COPPER FEEDER CONDUCTORS
- 3D 3-WIRE #10 COPPER FEEDER CONDUCTORS
- 3E 3-WIRE #12 COPPER FEEDER CONDUCTORS
- 4 INSTALL SMFO CABLE
- 5 INSTALL MMFO CABLE
- 6 INSTALL FIBER OPTIC DROP CABLE
- 7 INSTALL TRACER WIRE
- 8 TRENCH
- 9 INSTALL PVC CONDUIT
- 10 INSTALL RIGID, GALVANIZED STEEL CONDUIT
- 11 INSTALL RIGID, GALVANIZED STEEL RISER WITH WEATHERHEAD
- 12 INSTALL RIGID, GALVANIZED STEEL RISER WITH FIBER OPTIC CABLE SEAL
- 13 INSTALL OUTER-DUCT POLYETHYLENE CONDUIT
- 14 INSTALL POLYETHYLENE CONDUIT
- 15 DIRECTIONAL DRILL CONDUIT
- 16 BORE AND JACK CONDUIT
- 17 INSTALL CABLE(S) IN EXISTING CONDUIT
- 18 INSTALL CABLE(S) IN NEW CONDUIT
- 19 INSTALL CABLE(S) IN EXISTING RISER
- 20 INSTALL CABLE(S) IN NEW RISER
- 21 INSTALL CABLE(S) IN EXISTING CONDUIT STUBOUTS
- 22 INSTALL NEW CONDUIT INTO EXISTING CABINET BASE (USE EXISTING CONDUIT STUB-OUTS WHEN AVAILABLE)
- 23 INSTALL NEW RISER INTO EXISTING CABINET BASE (USE EXISTING CONDUIT STUB-OUTS WHEN AVAILABLE)
- 24 INSTALL NEW CONDUIT INTO EXISTING POLE MOUNTED CABINET
- 25 INSTALL NEW RISER INTO EXISTING POLE MOUNTED CABINET
- 26 TERMINATE COMMUNICATIONS CABLE ON EXISTING TELEMETRY INTERFACE PANEL IN TRAFFIC SIGNAL CONTROLLER CABINET
- 27 INSTALL NEW TELEMETRY INTERFACE PANEL IN TRAFFIC SIGNAL CONTROLLER CABINET
- 28 INSTALL INTERCONNECT CENTER, PATCH PANEL, JUMPERS, AND FUSION SPLICE CABLE IN CABINET
- 29 INSTALL UNDERGROUND SPLICE ENCLOSURE
- 30 INSTALL AERIAL SPLICE ENCLOSURE

- 31 MODIFY EXISTING SPLICE ENCLOSURE
- 32 INSTALL BASE MOUNTED SPLICE CABINET
- 33 REMOVE EXISTING SPLICE CABINET
- 34 INSTALL CABINET FOUNDATION
- 35 REMOVE EXISTING CABINET FOUNDATION
- 36 INSTALL CCTV CAMERA ASSEMBLY
- 37 INSTALL CCTV CAMERA WOOD POLE
- 38 INSTALL CCTV CAMERA METAL POLE AND FOUNDATION
- 39 INSTALL STANDARD JUNCTION BOX
- 40 INSTALL OVERSIZED JUNCTION BOX
- 41 REMOVE EXISTING JUNCTION BOX
- 42 INSTALL WOOD POLE
- 43 INSTALL 6" X 6" WOOD PEDESTAL
- 44 INSTALL AERIAL GUY ASSEMBLY
- 45 INSTALL STANDARD GUY ASSEMBLY
- 46 INSTALL SIDEWALK GUY ASSEMBLY
- 47 INSTALL MESSENGER CABLE
- 48 REMOVE EXISTING COMMUNICATIONS CABLE AND MESSENGER CABLE
- 49 REMOVE EXISTING COMMUNICATIONS CABLE
- 50 INSTALL TELEPHONE SERVICE
- 51 INSTALL CABLE STORAGE RACKS (SNOW SHOES) AND STORE 100 FEET OF CABLE
- 52 INSTALL DELINEATOR MARKER
- 53 STORE 30 FEET OF COMMUNICATIONS CABLE
- 54 LASH CABLE(S) TO EXISTING SIGNAL/COMMUNICATIONS CABLE
- 55 LASH CABLE(S) TO EXISTING MESSENGER CABLE
- 56 LASH CABLE(S) TO NEW MESSENGER CABLE
- 57 INSTALL NEW EQUIPMENT CABINET DISCONNECT
- 58 INSTALL NEW ELECTRICAL SERVICE
- 59 MODIFY ELECTRICAL SERVICE
- 60 INSTALL MICROWAVE VEHICLE DETECTION ASSEMBLY

- 61 INSTALL POLE MOUNTED EQUIPMENT CABINET
- 62 INSTALL INDUSTRIAL ETHERNET SWITCH
- 63 INSTALL FIBER OPTIC TRANSCEIVER
- 64 INSTALL VIDEO ENCODER
- 65 INSTALL VIDEO DECODER

CONSTRUCTION NOTE SYMBOLOGY KEY

- INDICATES NUMBER OF CABLES, LOOPS, ETC.
- INDICATES NUMBER OF FIBERS PER CABLE, TWISTED PAIRS PER CABLE, ETC.
- INDICATES NUMBER OF RISER(S)/CONDUIT(S)
- INDICATES DIAMETER OF RISER(S)/CONDUIT(S) (INCH)

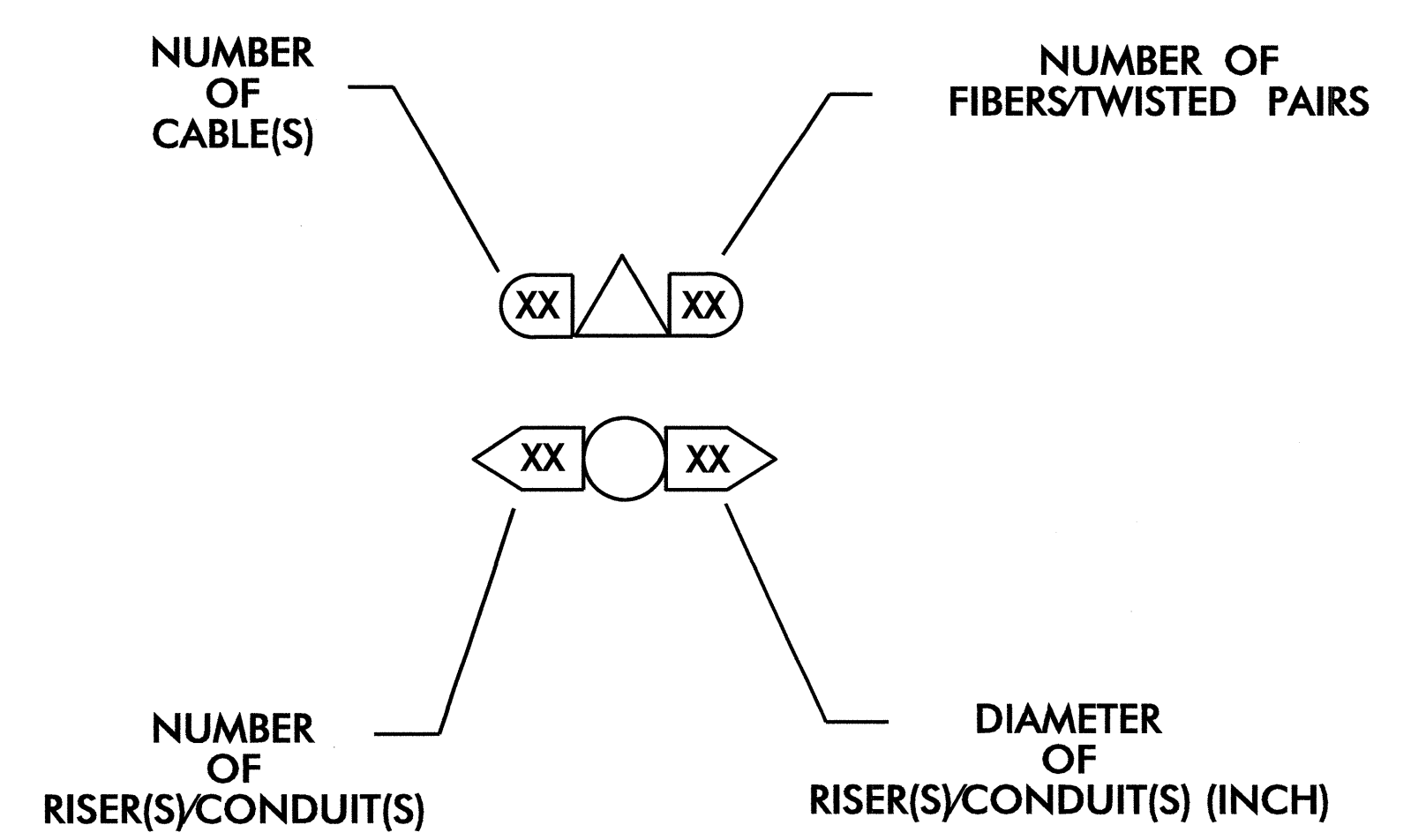

	CONSTRUCTION NOTES		SEAL
	PLAN DATE: SEPTEMBER 2011 PREPARED BY: G.A. GREEN	REVIEWED BY: M.A. ASLAMI, PE REVIEWED BY: T.G. PARKER	
SCALE 0 _____ N/A	REVISIONS _____ _____	INIT. DATE _____ _____	SIGNATURE
			DATE 10/5/11

INSET 'A'

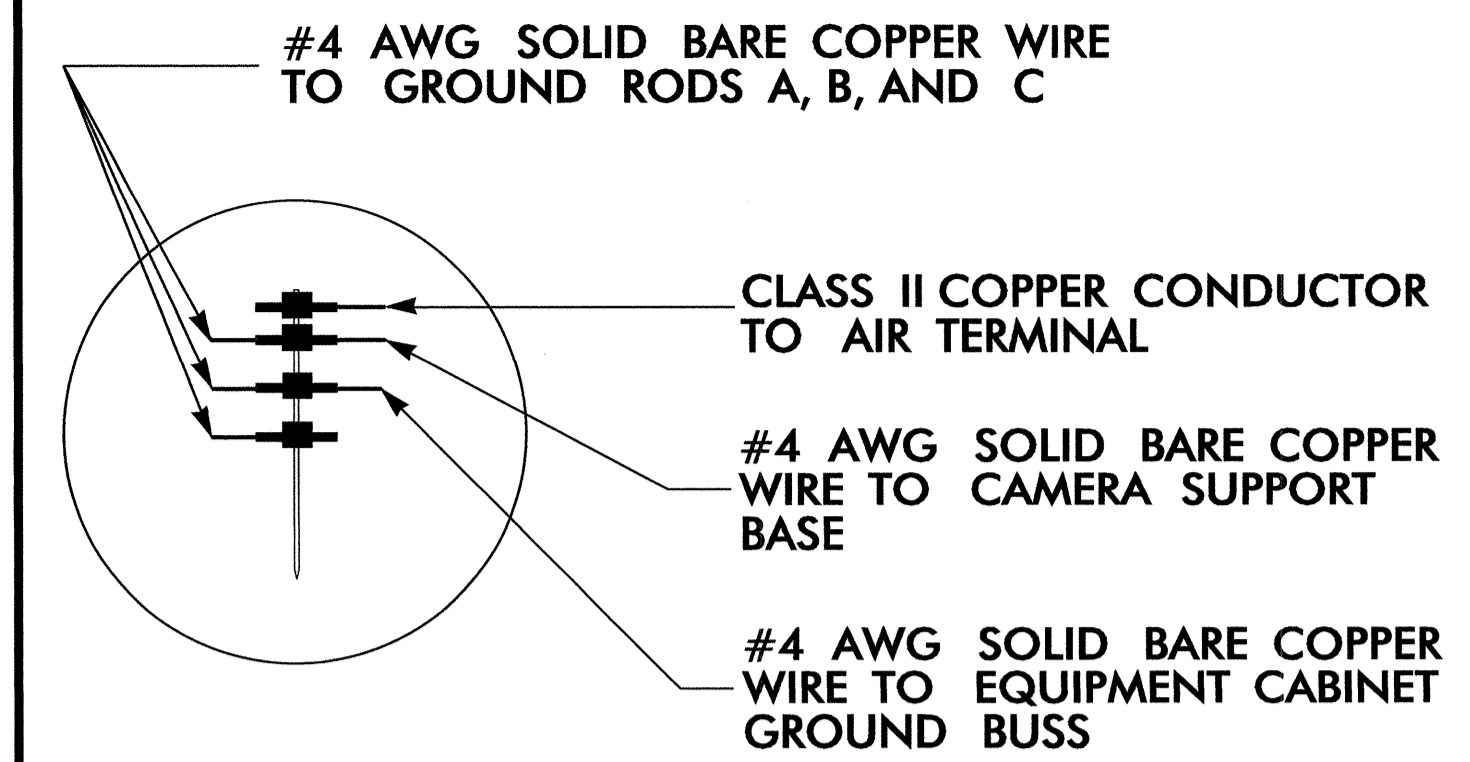

10 FOOT RADIUS EACH "SPHERE OF INFLUENCE"

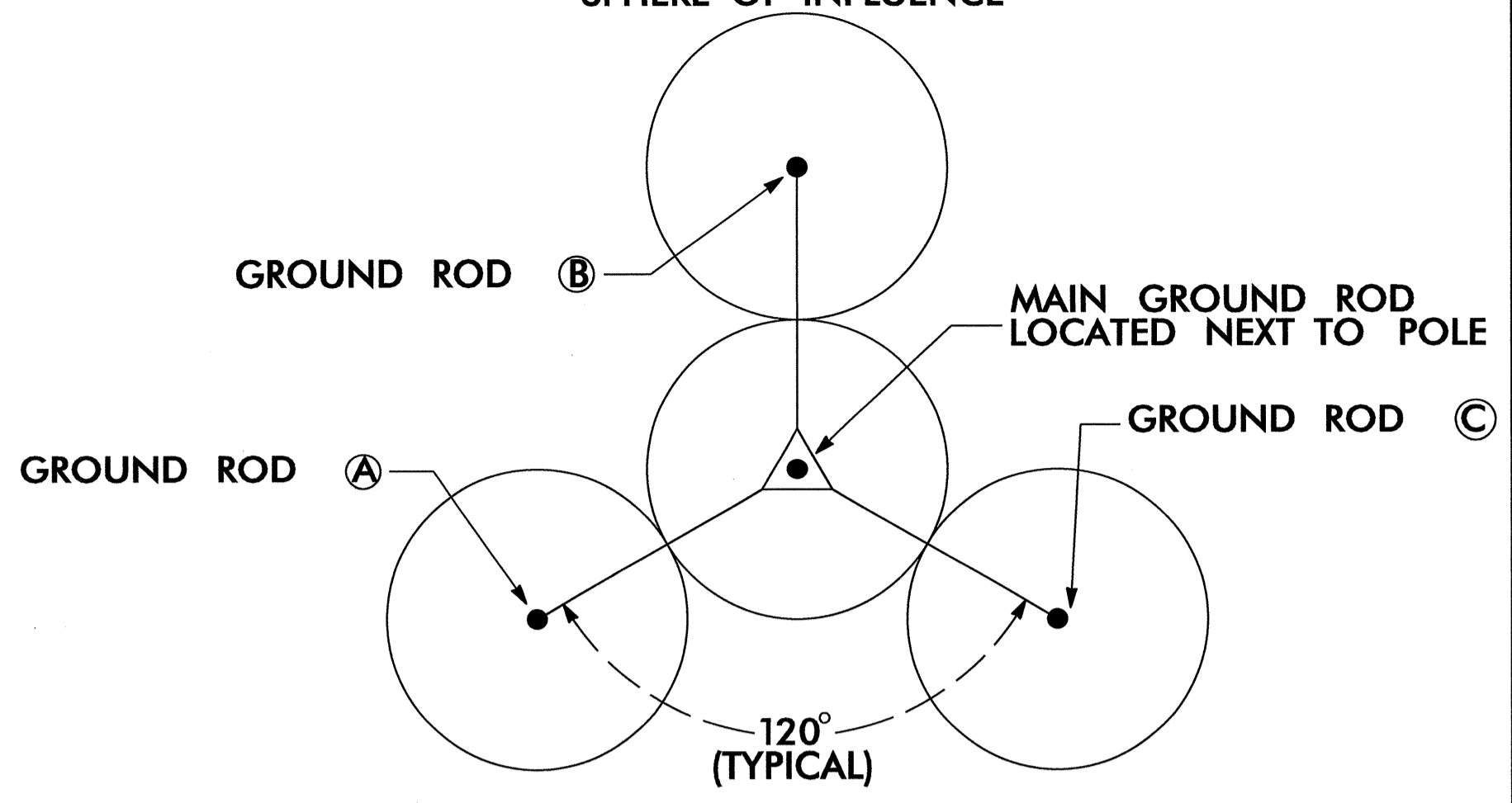

GROUND ROD PLACEMENT DETAIL (TYPICAL EACH POLE)

0.5 INCH X 36 INCH MINIMUM COPPER-CLAD AIR TERMINAL (CLASS II)

MECHANICALLY BOND CLASS II, 28 STRAND (MINIMUM), 15 AWG (MINIMUM) ROPE LAY BARE COPPER LIGHTNING CONDUCTOR TO THE AIR TERMINAL.

SECURE CLASS II, 28 STRAND (MINIMUM), 15 AWG (MINIMUM), ROPE-LAY BARE COPPER LIGHTNING CONDUCTOR TO THE POLE ON 24 INCH CENTERS. USE COPPER CABLE CLIPS DESIGNED FOR USE WITH THE CLASS II COPPER CONDUCTOR. SECURE EACH COPPER CABLE CLIP TO THE POLE USING A 0.25 INCH DIAMETER X 1.5 INCH LONG HEX HEAD, GALVANIZED SCREW.

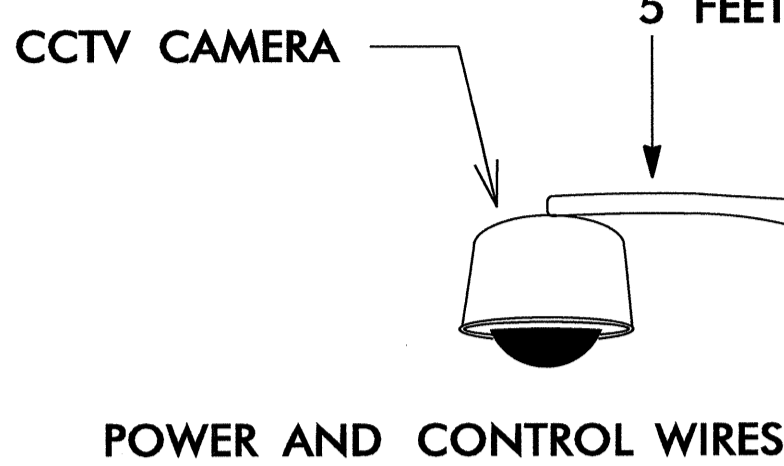

ELECTRICAL SERVICE DROP CONDUCTORS INSTALLED BY UTILITY COMPANY

BOND #4 AWG SOLID BARE COPPER WIRE TO CAMERA SUPPORT BASE BY AN ALUMINUM TO COPPER #2 - #14 AWG LUG. ATTACH TO CAMERA BASE WITH A STAINLESS STEEL SELF TAPPING SCREW. REMOVE PAINT OR PROTECTIVE COATING WHERE ATTACHING LUG ONLY.

INSTALL 2-INCH PVC U-GUARD OVER COPPER CONDUCTOR FROM GROUND LEVEL TO 10 FEET (MINIMUM) ABOVE THE GROUND.

1.25-INCH RIGID GALVANIZED STEEL RISER WITH WEATHERHEAD

2-INCH RIGID GALVANIZED STEEL RISER FOR POWER AND CONTROL WIRES

POLE MOUNT EQUIPMENT CABINET

METER BASE /DISCONNECT COMBINATION PANEL

SEE NOTE 5

ALTERNATE GROUNDING METHOD

IF SPACE IS NOT AVAILABLE TO DRIVE MULTIPLE RODS, DRIVE SECTIONAL GROUND RODS A MINIMUM OF 30 FEET.

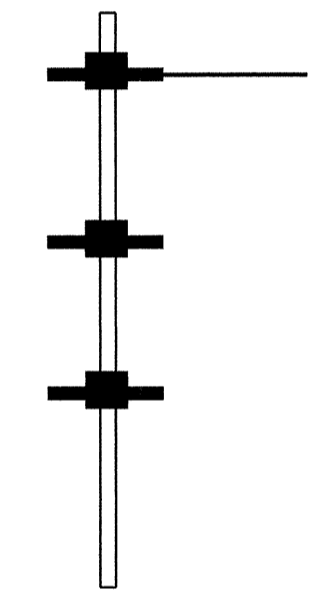

JOIN SECTIONAL GROUND RODS BY EXOTHERMIC WELDING CONNECTION

INSTALL ELECTRICAL SERVICE POLE NEAR RIGHT OF WAY OR AS DIRECTED BY THE ENGINEER.

INSTALL MARKER TAPE 12 INCHES BELOW GRADE AND ABOVE ALL GROUNDING CONDUCTORS.

FINISHED GRADE

24 INCH MIN.

EXOTHERMIC WELD

GROUND ROD (A)

TO GROUND ROD (B)

TO GROUND ROD (C)

TO EQUIPMENT CABINET GROUND BUSS

MAIN GROUND ROD INDICATED BY "●" IN GROUND ROD PLACEMENT DETAIL THIS SHEET

12 INCH MINIMUM

5/8 INCH X 10 FOOT MIN. COPPER CLAD STEEL GROUND RODS DRIVEN INTO UNDISTURBED EARTH

10 - 20 FEET

NOTES

1. BOND CLASS II, 28 STRAND (MINIMUM), 15 AWG (MINIMUM) ROPE-LAY BARE COPPER CONDUCTOR TO THE MAIN GROUND ROD BY AN EXOTHERMIC WELD METHOD. MAINTAIN MAXIMUM HORIZONTAL SEPARATION BETWEEN COPPER CONDUCTOR AND RISER.
2. EXOTHERMICALLY WELD ALL CONNECTIONS TO GROUND RODS.
3. THE CONTRACTOR MAY, UPON APPROVAL OF THE ENGINEER, INSTALL A 30-FOOT SECTIONAL GROUND ROD FOR INSTANCES WHEN CONDITIONS WILL NOT ALLOW FOR THE INSTALLATION OF THE 3 - RADIAL GROUND RODS.
4. INSTALL MARKER TAPE DIRECTLY ABOVE ALL GROUNDING ELECTRODES AND CONDUCTORS AT A DEPTH OF 12 INCHES.
5. REMOVE BONDING JUMPER BETWEEN EQUIPMENT CABINET GROUND BUSS AND NEUTRAL BUSS.

CCTV CAMERA INSTALLATION FOR WOOD POLES WITH NEW AERIAL ELECTRICAL SERVICE TYPICAL DETAIL

PLAN DATE: SEPTEMBER 2011	REVIEWED BY: M.A. ASLAMI, PE
PREPARED BY: G.A. GREEN	REVIEWED BY: T.G. PARKER
REVISIONS	INIT. DATE



SEAL

PROFESSIONAL ENGINEER

SEAL 023919

GREGORY A. FULLER

750 N. Greenfield Place, Garner, NC 27529

SCALE: 0 N/A

SIGNATURE: *Gregory A. Fuller* DATE: 10/5/11

INSET 'A'

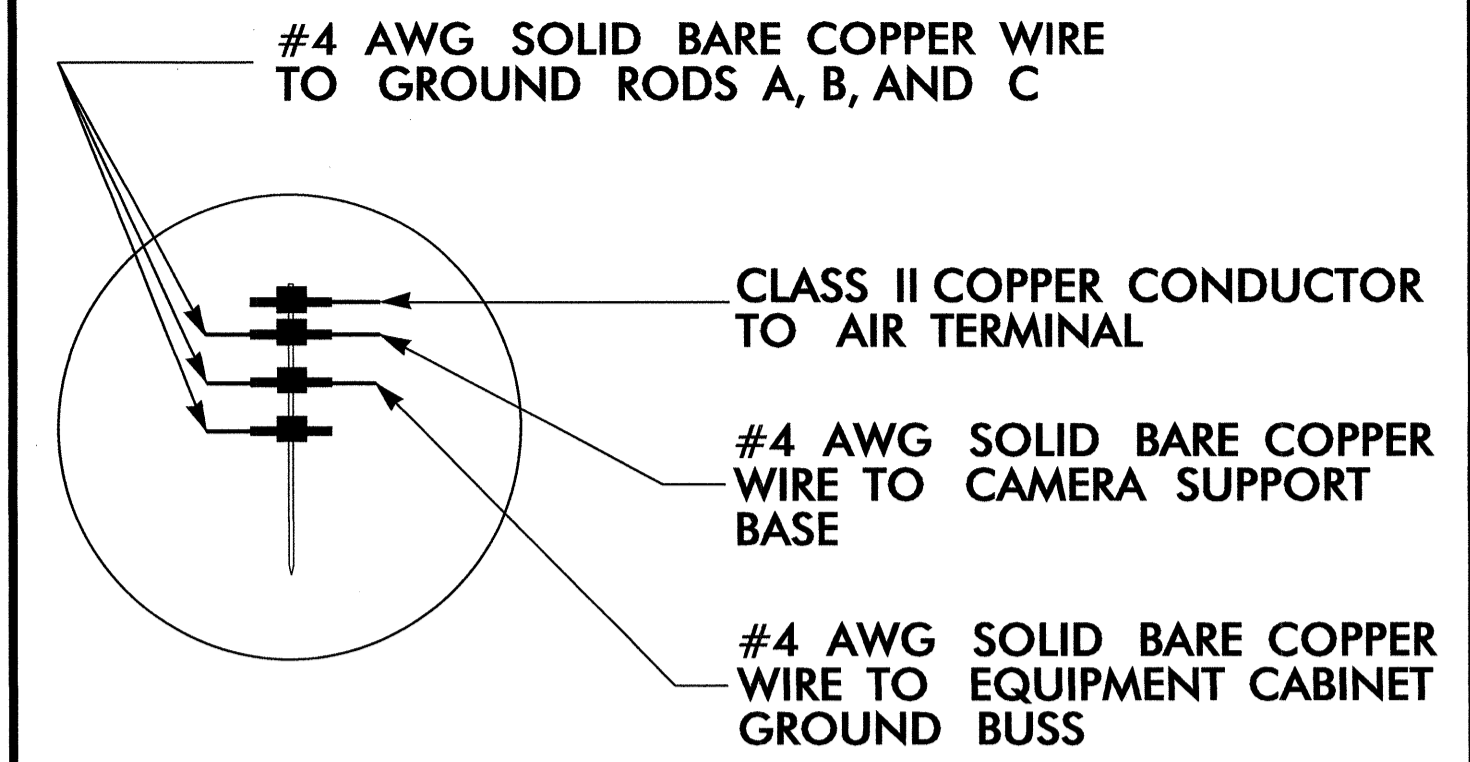

10 FOOT RADIUS EACH "SPHERE OF INFLUENCE"

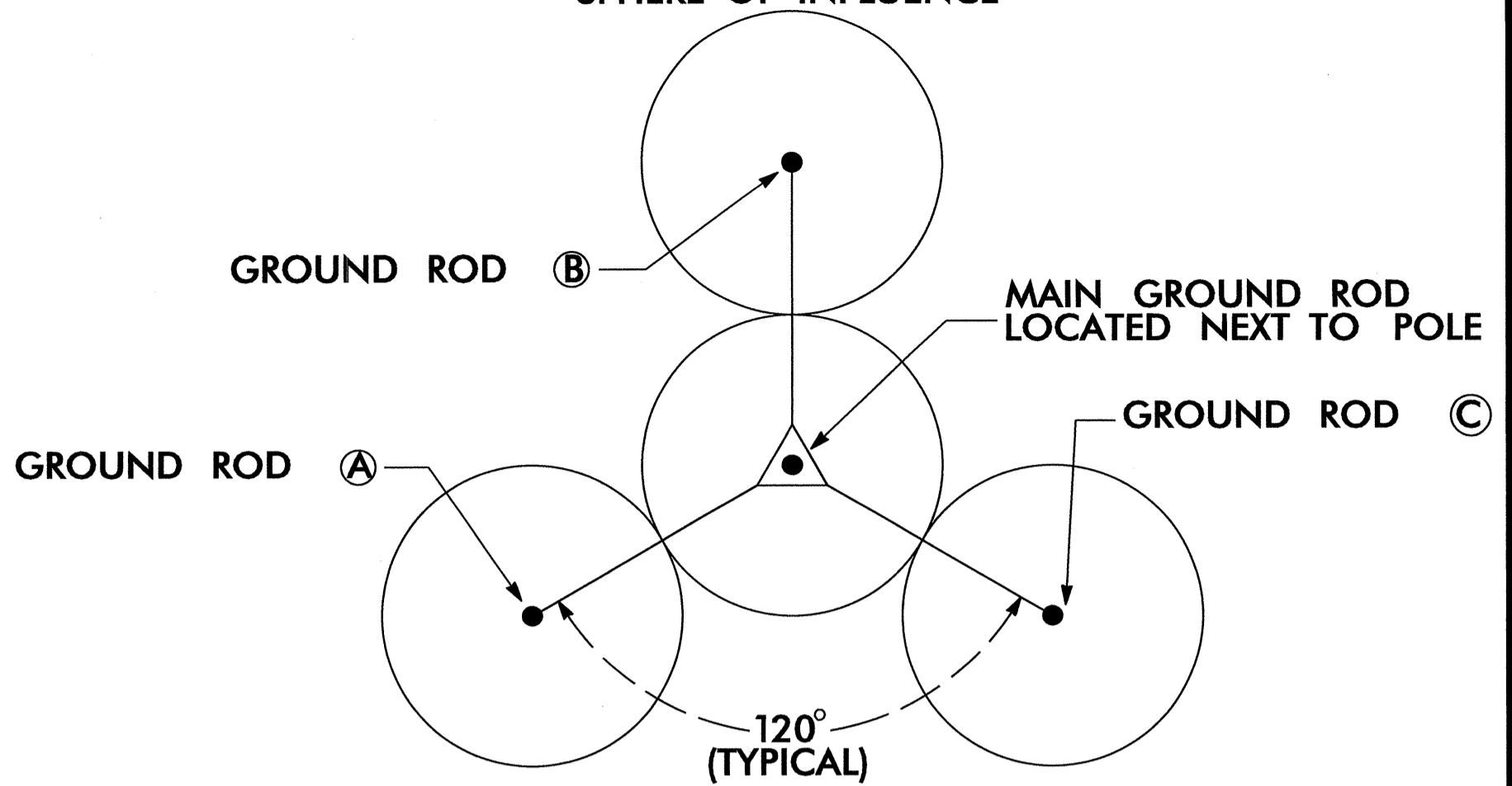

GROUND ROD PLACEMENT DETAIL (TYPICAL EACH POLE)

0.5 INCH X 36 INCH MINIMUM COPPER-CLAD AIR TERMINAL (CLASS II)

MECHANICALLY BOND CLASS II, 28 STRAND (MINIMUM), 15 AWG (MINIMUM) ROPE LAY BARE COPPER LIGHTNING CONDUCTOR TO THE AIR TERMINAL.

SECURE CLASS II, 28 STRAND (MINIMUM), 15 AWG (MINIMUM), ROPE-LAY BARE COPPER LIGHTNING CONDUCTOR TO THE POLE ON 24 INCH CENTERS. USE COPPER CABLE CLIPS DESIGNED FOR USE WITH THE CLASS II COPPER CONDUCTOR. SECURE EACH COPPER CABLE CLIP TO THE POLE USING A 0.25 INCH DIAMETER X 1.5 INCH LONG HEX HEAD, GALVANIZED SCREW.

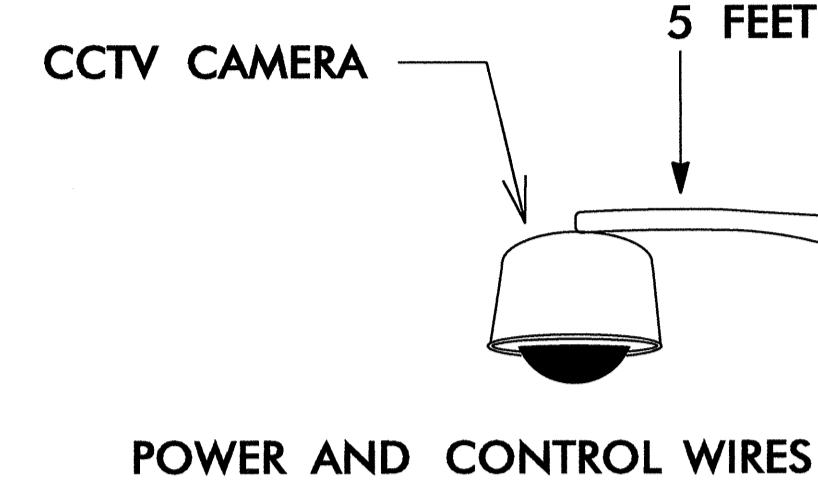

BOND #4 AWG SOLID BARE COPPER WIRE TO CAMERA SUPPORT BASE BY AN ALUMINUM TO COPPER #2 - #14 AWG LUG. ATTACH TO CAMERA BASE WITH A STAINLESS STEEL SELF TAPPING SCREW. REMOVE PAINT OR PROTECTIVE COATING WHERE ATTACHING LUG ONLY.

INSTALL 2-INCH PVC U-GUARD OVER COPPER CONDUCTOR FROM GROUND LEVEL TO 10 FEET (MINIMUM) ABOVE THE GROUND.

2-INCH RIGID GALVANIZED STEEL RISER FOR POWER AND CONTROL WIRES

INSTALL MARKER TAPE 12 INCHES BELOW GRADE AND ABOVE ALL GROUNDING CONDUCTORS.

FINISHED GRADE

24 INCH MIN.

EXOTHERMIC WELD

GROUND ROD A

TO GROUND ROD B

TO GROUND ROD C

MAIN GROUND ROD INDICATED BY "▲" IN GROUND ROD PLACEMENT DETAIL THIS SHEET

5/8 INCH X 10 FOOT MIN. COPPER CLAD STEEL GROUND RODS DRIVEN INTO UNDISTURBED EARTH

10 - 20 FEET

12 INCH MINIMUM

NOTES

1. BOND CLASS II, 28 STRAND (MINIMUM), 15 AWG (MINIMUM) ROPE-LAY BARE COPPER CONDUCTOR TO THE MAIN GROUND ROD BY AN EXOTHERMIC WELD METHOD. MAINTAIN MAXIMUM HORIZONTAL SEPARATION BETWEEN COPPER CONDUCTOR AND RISER.
2. EXOTHERMICALLY WELD ALL CONNECTIONS TO GROUND RODS.
3. THE CONTRACTOR MAY, UPON APPROVAL OF THE ENGINEER, INSTALL A 30-FOOT SECTIONAL GROUND ROD FOR INSTANCES WHEN CONDITIONS WILL NOT ALLOW FOR THE INSTALLATION OF THE 3 - RADIAL GROUND RODS.
4. INSTALL MARKER TAPE DIRECTLY ABOVE ALL GROUNDING ELECTRODES AND CONDUCTORS AT A DEPTH OF 12 INCHES.
5. REMOVE BONDING JUMPER BETWEEN EQUIPMENT CABINET GROUND BUSS AND NEUTRAL BUSS.

ALTERNATE GROUNDING METHOD

IF SPACE IS NOT AVAILABLE TO DRIVE MULTIPLE RODS, DRIVE SECTIONAL GROUND RODS A MINIMUM OF 30 FEET.

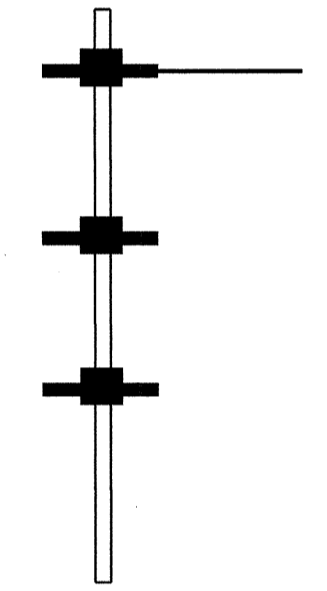

JOIN SECTIONAL GROUND RODS BY EXOTHERMIC WELDING CONNECTION

CCTV CAMERA INSTALLATION FOR WOOD PEDESTAL WITH UNDERGROUND ELECTRICAL SERVICE TYPICAL DETAIL

PLAN DATE: SEPTEMBER 2011	REVIEWED BY: M.A. ASLAMI, PE
PREPARED BY: G.A. GREEN	REVIEWED BY: T.G. PARKER
REVISIONS	INIT. DATE

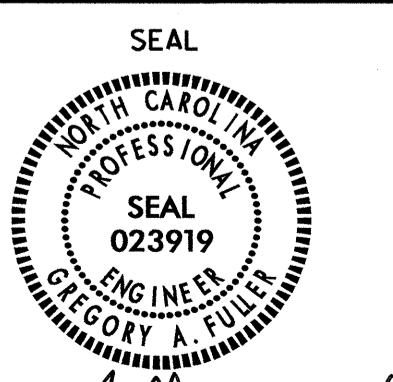
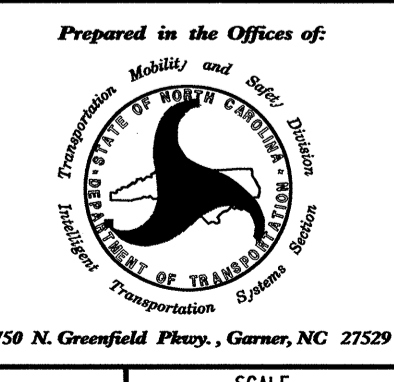



750 N. Greenfield Place, Garner, NC 27529

SCALE: 0 N/A

SIGNATURE: Gregory A. Fuller DATE: 10/5/11

QUANTITIES

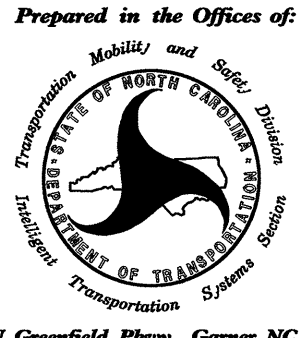
**SEE
SUMMARY
OF
QUANTITIES**

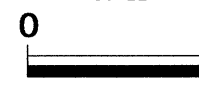
 <p>Prepared in the Offices of: Transportation Mobility and Safe Driving DEPARTMENT OF TRANSPORTATION 750 N. Greenfield Pkwy., Garner, NC 27529</p>	QUANTITIES		
	DIVISION 07 GUILFORD & ROCKINGHAM CO.		
SCALE  N/A	PLAN DATE: SEPTEMBER 2011 PREPARED BY: G.A. GREEN	REVIEWED BY: M.A. ASLAMI, PE REVIEWED BY: T.G. PARKER	REVISIONS INIT. DATE _____ _____ _____
CADD Filename:			SIGNATURE: <i>Gregory A. Fuller</i> DATE: 10/5/11

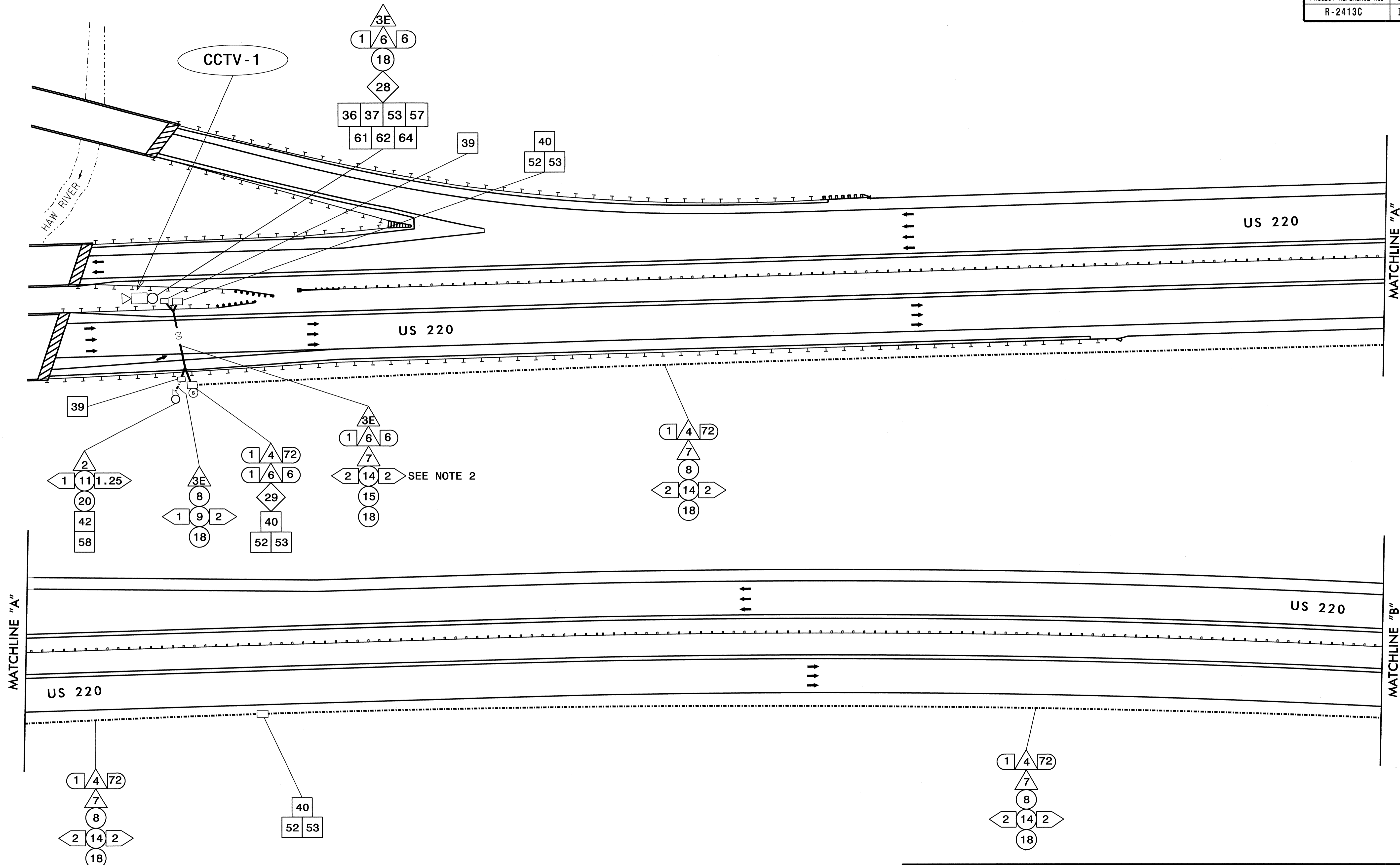

NOTES

1. MAINTAIN A MINIMUM OF SIX (6) FEET FROM EDGE OF PAVEMENT WHEN TRENCHING PARALLEL TO THE ROADWAY. MAXIMUM JUNCTION BOX SPACING 1500' OR AS DIRECTED BY THE ENGINEER.
2. INSTALL CONDUITS FOR FEEDER CONDUCTORS AND FIBER OPTIC CABLE FOR NEW CCTV IN SAME BORE AND USE SEPARATE CONDUIT AND JUNCTION BOXES.
3. COMMUNICATIONS WITH THE TRTMC WILL BE INSTALLED BY OTHERS.

<p>750 N. Greenfield Pkwy., Garner, NC 27529</p>	<p>CCTV INSTALLATIONS</p>		
	<p>DIVISION 07 GUILFORD CO.</p>		
<p>SCALE 0 N/A</p>	<p>PLAN DATE: SEPTEMBER 2011 PREPARED BY: G.A. GREEN</p>	<p>REVIEWED BY: M.A. ASLAMI, PE REVIEWED BY: T.G. PARKER</p>	<p>INIT. DATE SIGNATURE: <i>Gregory A. Fuller</i> 10/5/11 DATE</p>

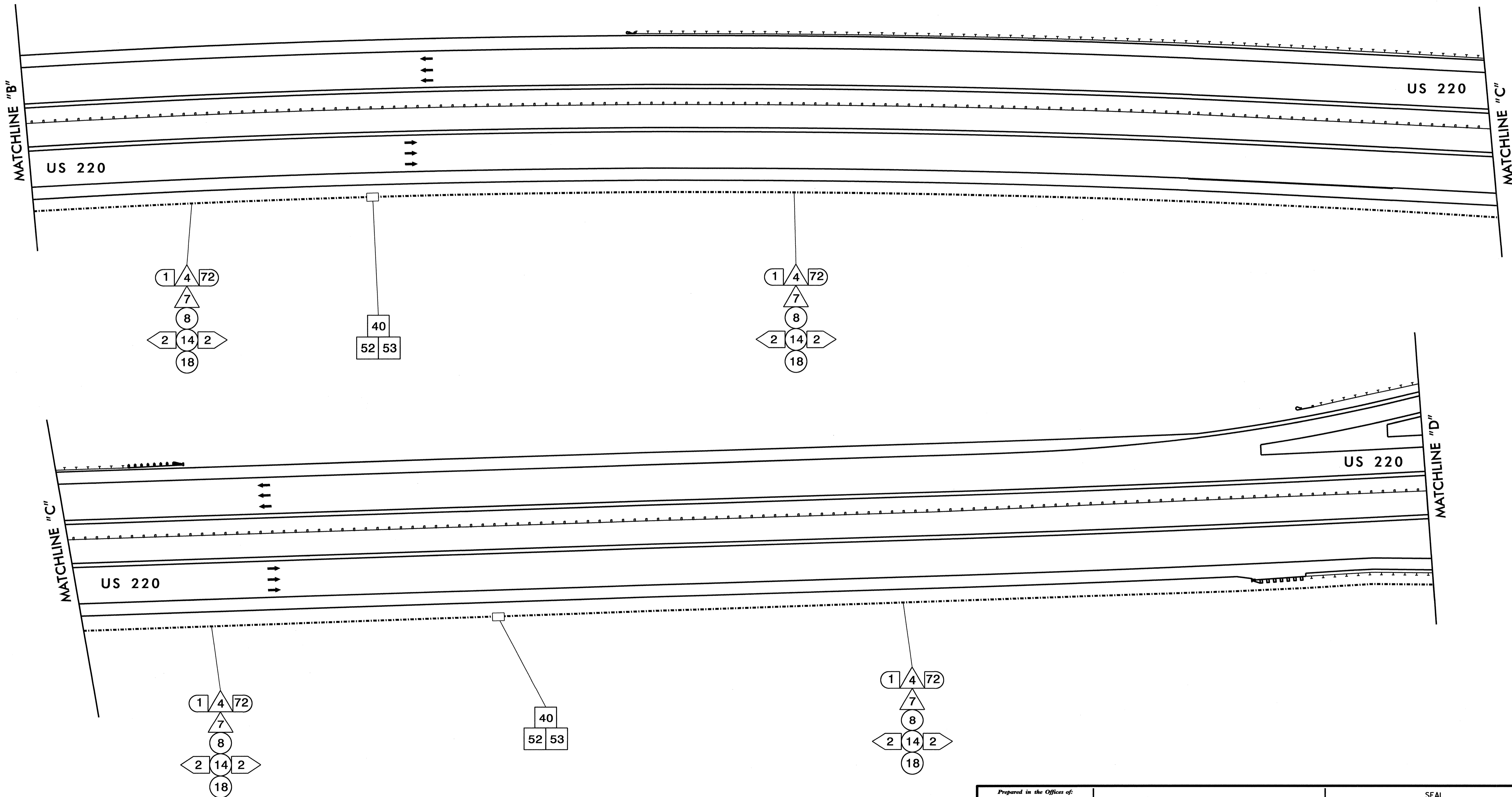

NOTES

1. MAINTAIN A MINIMUM OF SIX (6) FEET FROM EDGE OF PAVEMENT WHEN TRENCHING PARALLEL TO THE ROADWAY. MAXIMUM JUNCTION BOX SPACING 1500' OR AS DIRECTED BY THE ENGINEER.

	CCTV INSTALLATIONS		
	DIVISION 07 GUILFORD CO.		
Prepared in the Offices of: G.A. Green & Associates, Inc. 750 N. Greenfield Place - Greensboro, NC 27409	PLAN DATE: SEPTEMBER 2011 PREPARED BY: G.A. GREEN	REVIEWED BY: M.A. ASLAMI, PE REVIEWED BY: T.G. PARKER	SCALE: 0 N/A REVISIONS: _____ INIT.: _____ DATE: _____
Signature: <i>Gregory A. Fuller</i>			Date: 10/5/11

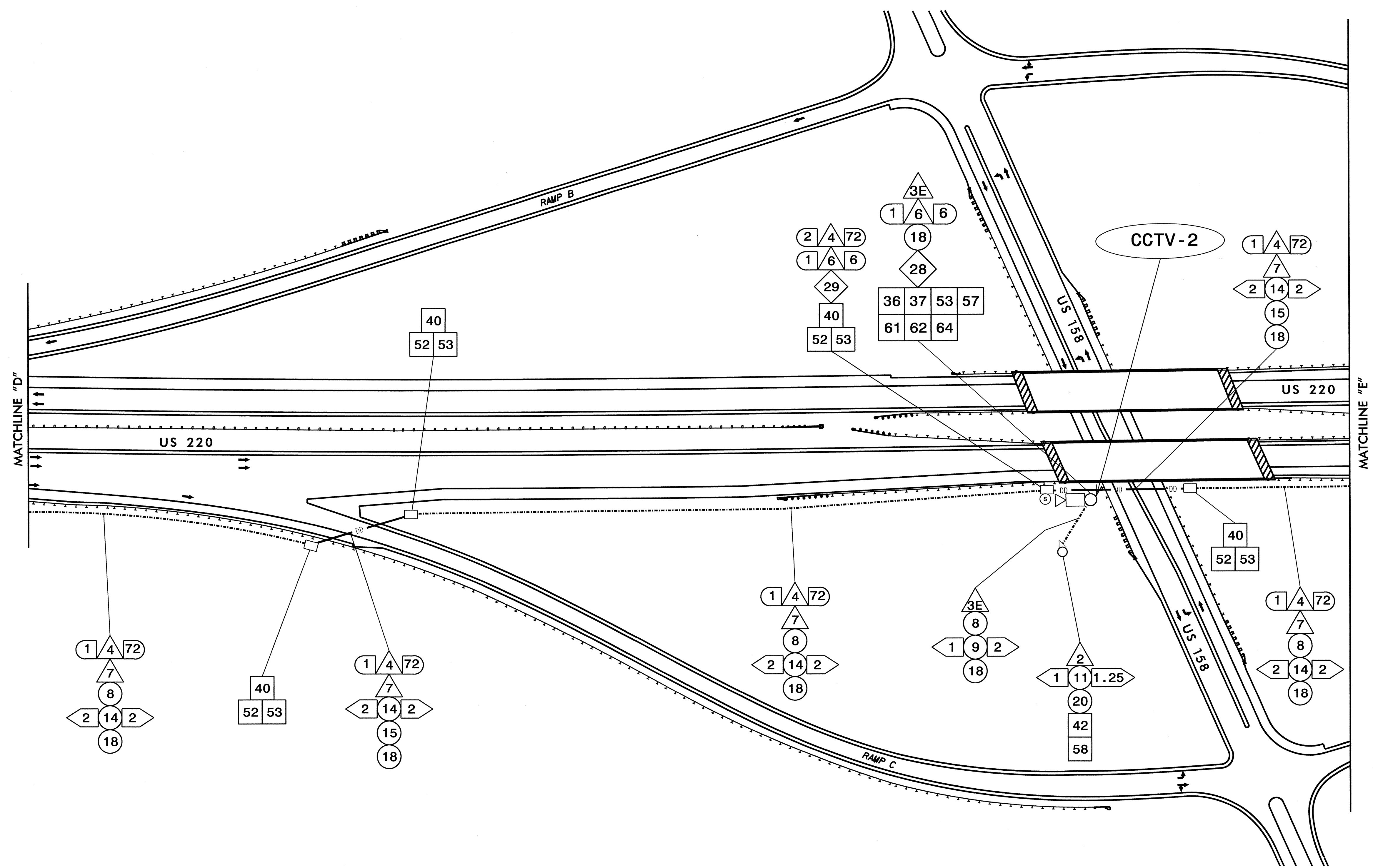

NOTES

1. MAINTAIN A MINIMUM OF SIX (6) FEET FROM EDGE OF PAVEMENT WHEN TRENCHING PARALLEL TO THE ROADWAY. MAXIMUM JUNCTION BOX SPACING 1500' OR AS DIRECTED BY THE ENGINEER.

<p>Prepared in the Offices of: Department of Transportation 750 N. Greenfield Pkwy., Garner, NC 27529</p>	<p>CCTV INSTALLATIONS</p>		
	<p>DIVISION 07 GUILFORD CO.</p>		
<p>PLAN DATE: SEPTEMBER 2011</p>	<p>REVIEWED BY: M.A. ASLAMI, PE</p>		<p>INIT. DATE</p>
<p>PREPARED BY: G.A. GREEN</p>	<p>REVIEWED BY: T.G. PARKER</p>		
<p>SCALE 0 N/A</p>	<p>REVISIONS</p>	<p>INIT.</p>	<p>DATE</p>
<p>CADD Filename:</p>			<p><i>Gregory A. Fuller</i> 10/5/11 SIGNATURE DATE</p>

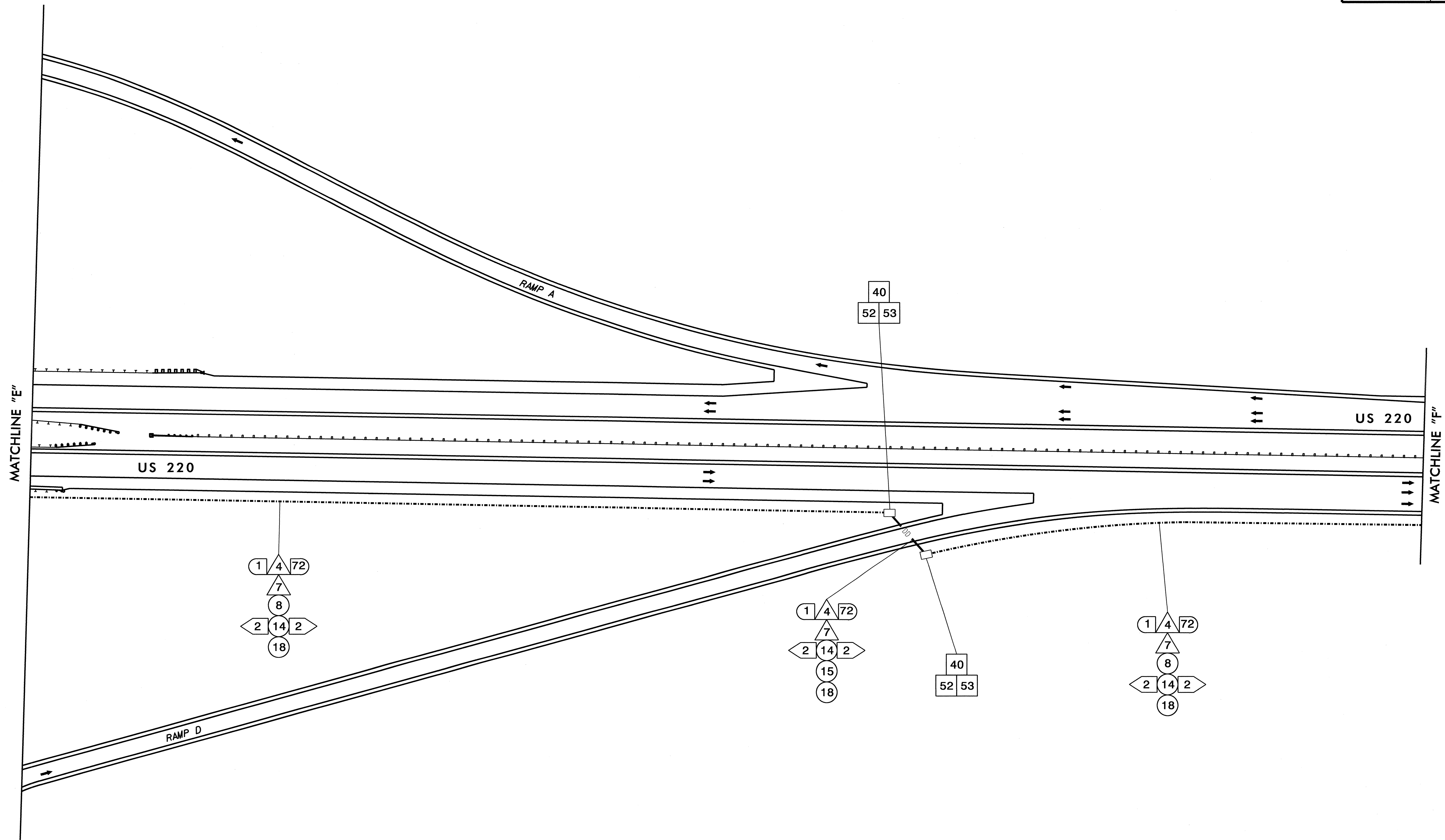

NOTES

1. MAINTAIN A MINIMUM OF SIX (6) FEET FROM EDGE OF PAVEMENT WHEN TRENCHING PARALLEL TO THE ROADWAY. MAXIMUM JUNCTION BOX SPACING 1500' OR AS DIRECTED BY THE ENGINEER.

<p>Prepared in the Offices of: Department of Transportation 750 N. Greenfield Place, Greensboro, NC 27529</p>	<p>CCTV INSTALLATIONS</p>		
	<p>DIVISION 07 GUILFORD CO.</p>		
<p>PLAN DATE: SEPTEMBER 2011</p>	<p>REVIEWED BY: M.A. ASLAMI, PE</p>		<p>INIT. DATE</p>
<p>PREPARED BY: G.A. GREEN</p>	<p>REVIEWED BY: T.G. PARKER</p>		
<p>SCALE 0 N/A</p>	<p>REVISIONS</p>	<p>INIT.</p>	<p>DATE</p>
<p>CADD Filename:</p>			<p>10/5/11</p>

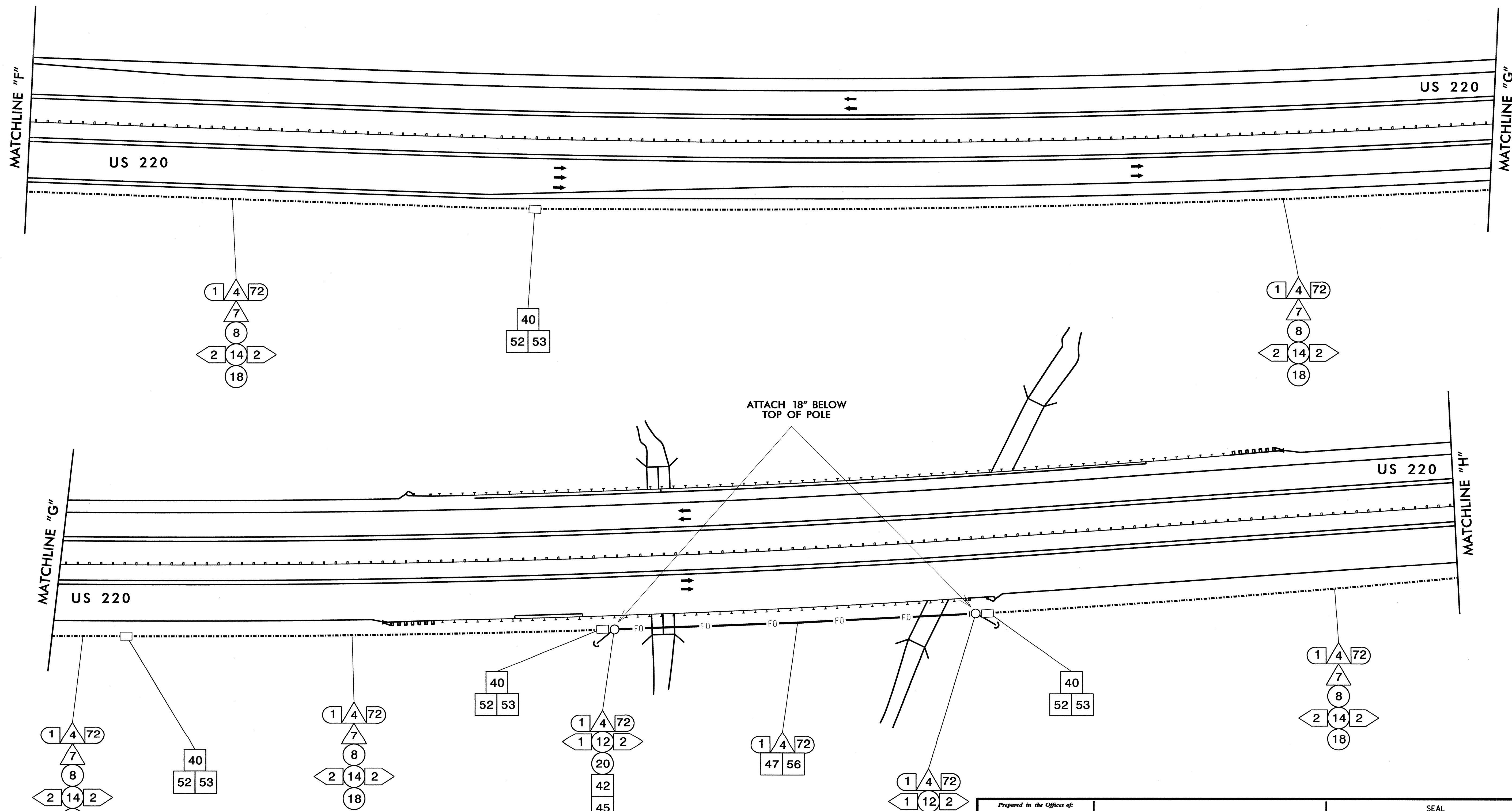

NOTES

1. MAINTAIN A MINIMUM OF SIX (6) FEET FROM EDGE OF PAVEMENT WHEN TRENCHING PARALLEL TO THE ROADWAY. MAXIMUM JUNCTION BOX SPACING 1500' OR AS DIRECTED BY THE ENGINEER.

BOND RISER AND MESSENGER CABLE TO POLE GROUND

BOND RISER AND MESSENGER CABLE TO POLE GROUND

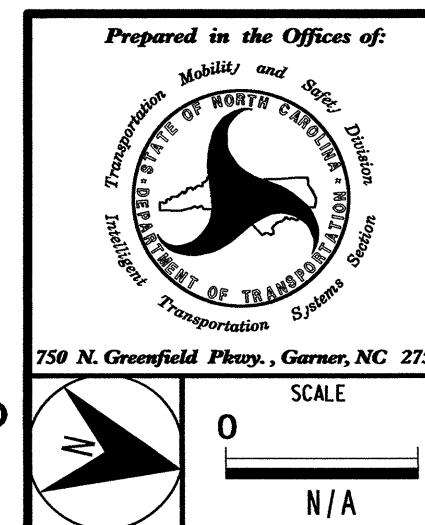

CCTV INSTALLATIONS	
DIVISION 07 GUILFORD CO.	
PLAN DATE: SEPTEMBER 2011	REVIEWED BY: M.A. ASLAMI, PE
PREPARED BY: G.A. GREEN	REVIEWED BY: T.G. PARKER
REVISIONS	INIT. DATE

SEAL

SEAL
 NORTH CAROLINA
 PROFESSIONAL ENGINEER
 GREGORY A. FULLER
 023919

Signature: *Gregory A. Fuller* Date: 10/5/11

CADD File name:

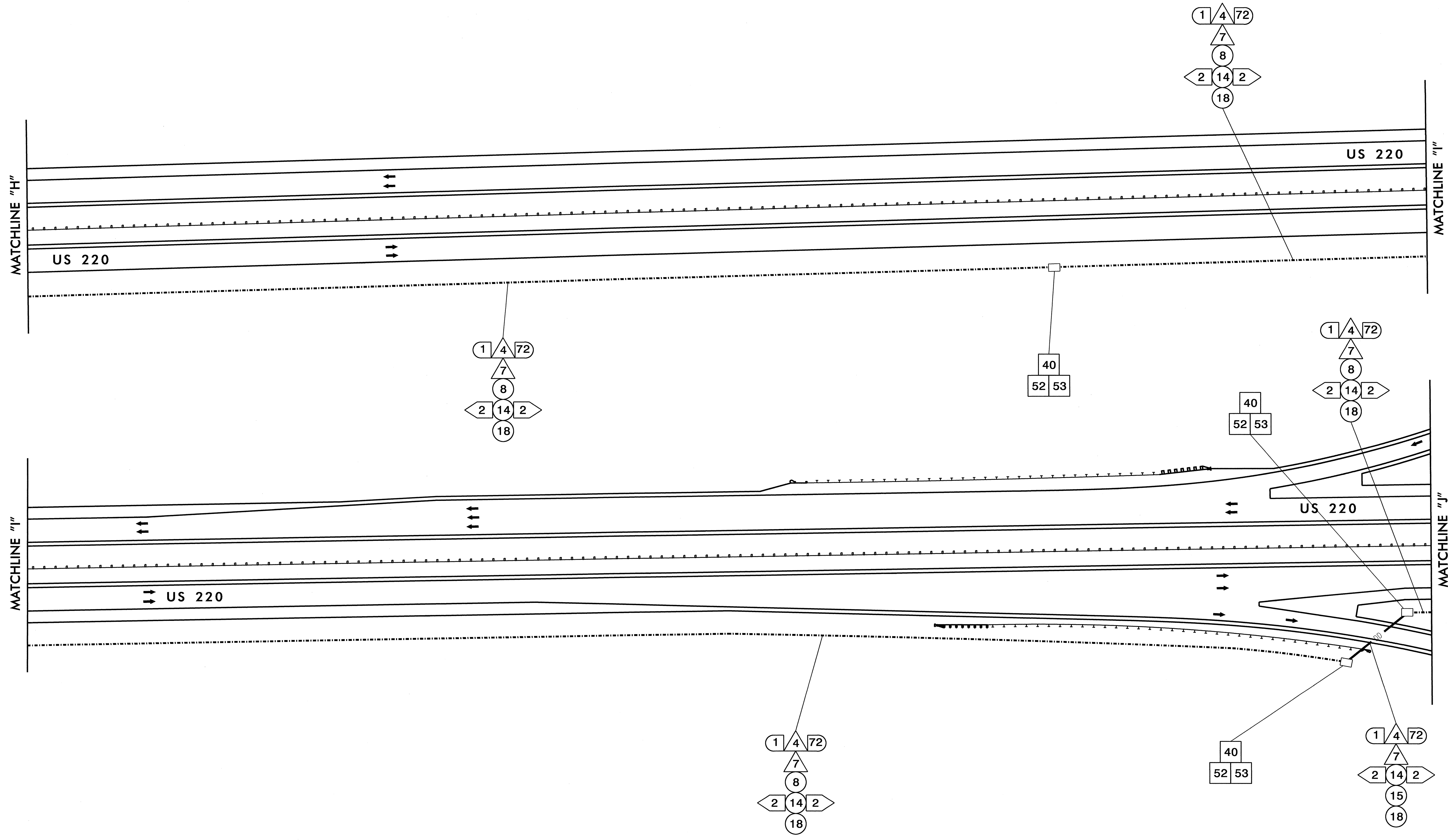

NOTES

1. MAINTAIN A MINIMUM OF SIX (6) FEET FROM EDGE OF PAVEMENT WHEN TRENCHING PARALLEL TO THE ROADWAY. MAXIMUM JUNCTION BOX SPACING 1500' OR AS DIRECTED BY THE ENGINEER.

	CCTV INSTALLATIONS		
	DIVISION 07 ROCKINGHAM CO. PLAN DATE: SEPTEMBER 2011 REVIEWED BY: M.A. ASLAMI, PE PREPARED BY: G.A. GREEN REVIEWED BY: T.G. PARKER		
SCALE 0' = 1" / N/A	REVISIONS _____ _____ _____	INIT. DATE _____ _____	SIGNATURE: <i>Gregory A. Fuller</i> DATE: 10/5/11 CADD File Name:

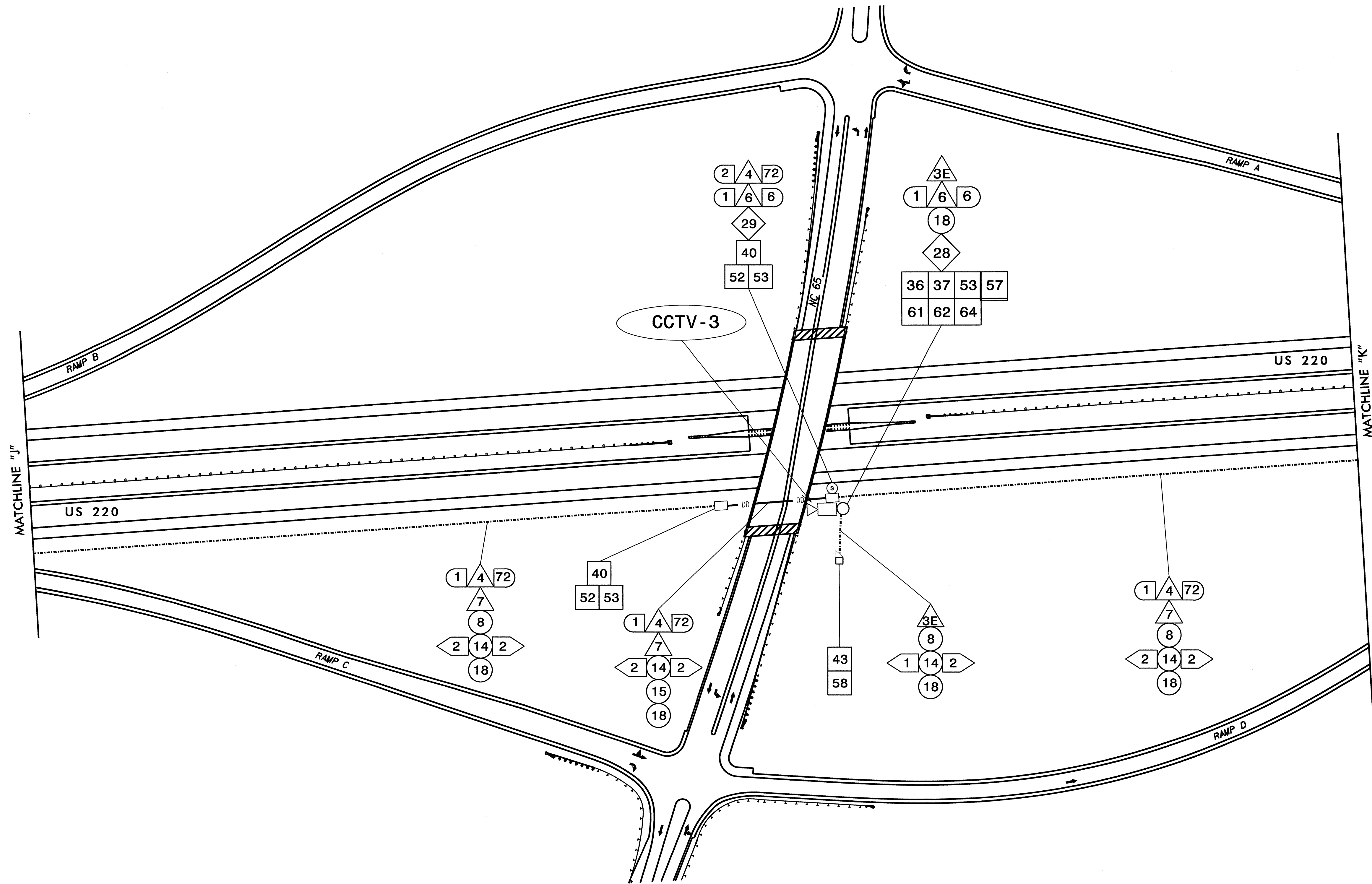

NOTES

1. MAINTAIN A MINIMUM OF SIX (6) FEET FROM EDGE OF PAVEMENT WHEN TRENCHING PARALLEL TO THE ROADWAY. MAXIMUM JUNCTION BOX SPACING 1500' OR AS DIRECTED BY THE ENGINEER.
2. INSTALL CCTV-3 THIRTY (30) FEET FROM US 220 NORTH BOUND EGDE OF TRAVEL LANE.

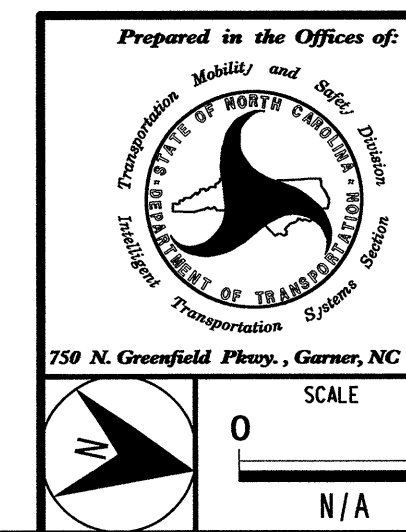

CCTV INSTALLATIONS	
DIVISION 07 ROCKINGHAM CO.	
PLAN DATE: SEPTEMBER 2011	REVIEWED BY: M.A. ASLAMI, PE
PREPARED BY: G.A. GREEN	REVIEWED BY: T.G. PARKER
REVISIONS	INIT. DATE

SEAL NORTH CAROLINA PROFESSIONAL ENGINEER GREGORY A. FULLER 023919	 10/5/11 DATE
---	---------------------

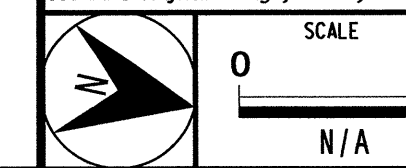

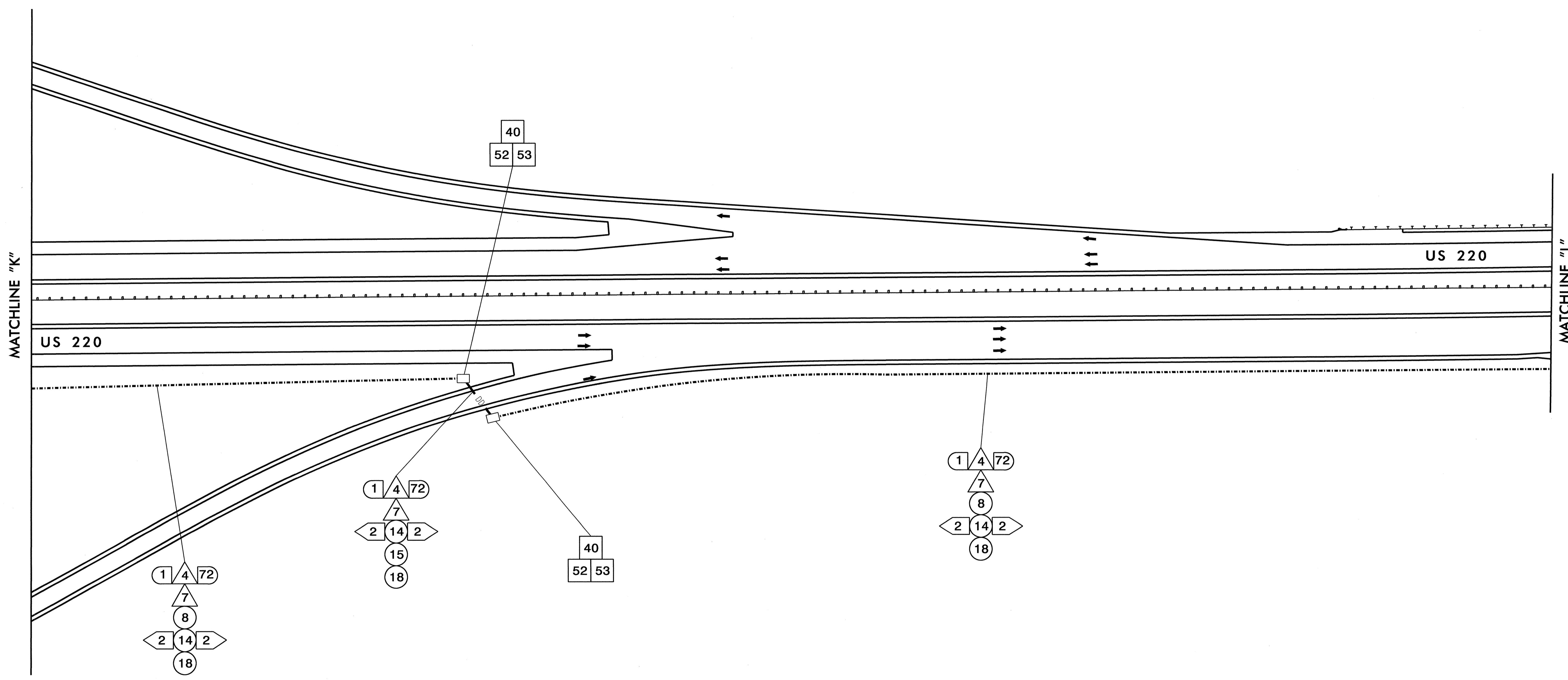

NOTES

1. MAINTAIN A MINIMUM OF SIX (6) FEET FROM EDGE OF PAVEMENT WHEN TRENCHING PARALLEL TO THE ROADWAY. MAXIMUM JUNCTION BOX SPACING 1500' OR AS DIRECTED BY THE ENGINEER.

	CCTV INSTALLATIONS		
	DIVISION 07 ROCKINGHAM CO.		
PLAN DATE: SEPTEMBER 2011 REVIEWED BY: M.A. ASLAMI, PE		PREPARED BY: G.A. GREEN REVIEWED BY: T.G. PARKER	
SCALE: 0 N/A		REVISIONS	INIT. DATE
			SIGNATURE: <i>Gregory A. Fuller</i> DATE: 10/5/11

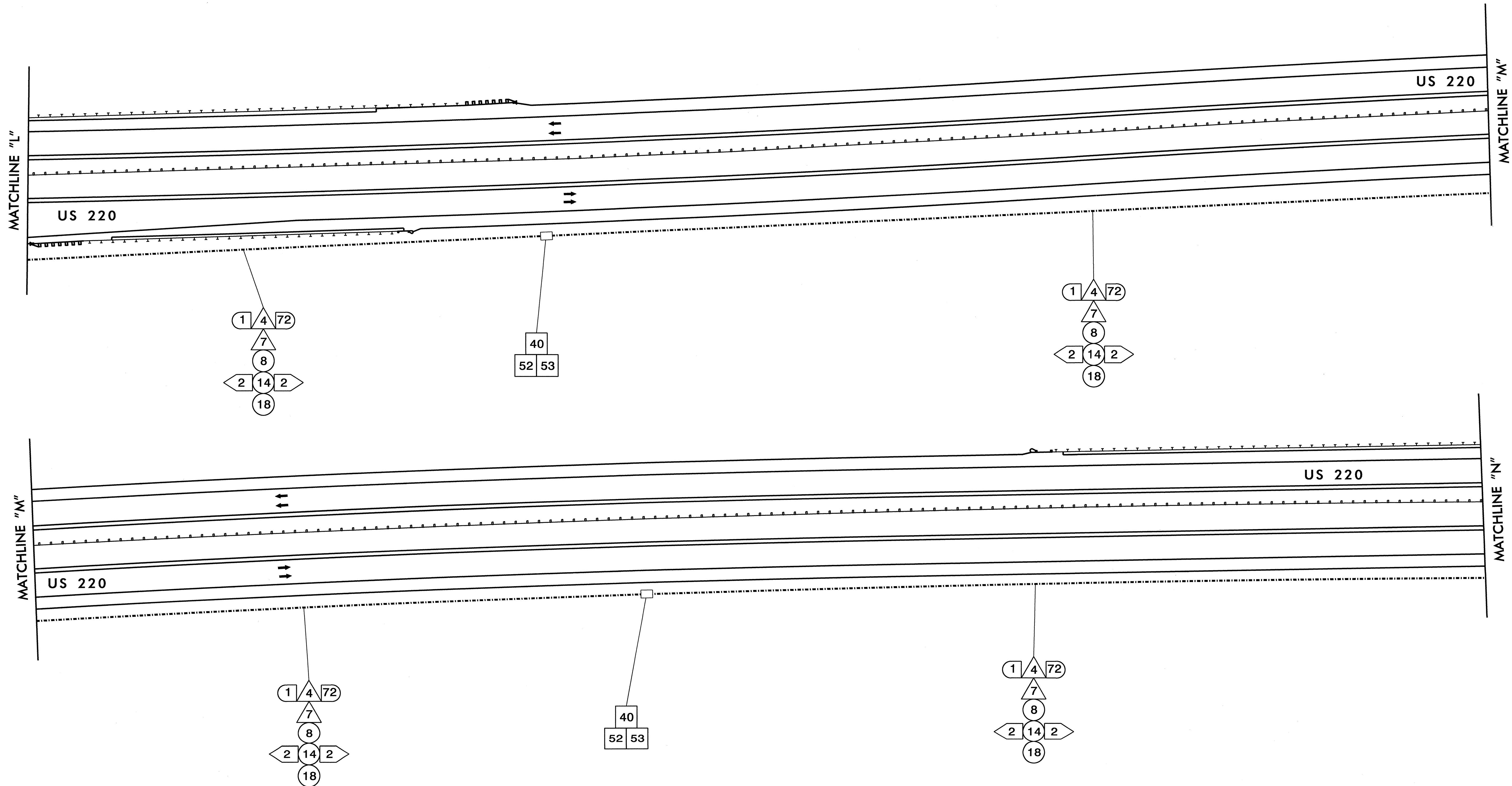

NOTES

1. MAINTAIN A MINIMUM OF SIX (6) FEET FROM EDGE OF PAVEMENT WHEN TRENCHING PARALLEL TO THE ROADWAY. MAXIMUM JUNCTION BOX SPACING 1500' OR AS DIRECTED BY THE ENGINEER.

	CCTV INSTALLATIONS																
	DIVISION 07 ROCKINGHAM CO. PLAN DATE: SEPTEMBER 2011 REVIEWED BY: M.A. ASLAMI, PE PREPARED BY: G.A. GREEN REVIEWED BY: T.G. PARKER																
	<table border="1"> <thead> <tr> <th>REVISIONS</th> <th>INIT.</th> <th>DATE</th> </tr> </thead> <tbody> <tr> <td> </td> <td> </td> <td> </td> </tr> <tr> <td> </td> <td> </td> <td> </td> </tr> </tbody> </table>	REVISIONS	INIT.	DATE							<table border="1"> <tr> <td colspan="2" style="text-align: center;"> </td> </tr> <tr> <td style="text-align: center;"> SIGNATURE </td> <td style="text-align: center;"> DATE </td> </tr> <tr> <td style="text-align: center;"> 10/5/11 </td> <td style="text-align: center;"> DATE </td> </tr> </table>			SIGNATURE	DATE	10/5/11	DATE
REVISIONS	INIT.	DATE															
SIGNATURE	DATE																
10/5/11	DATE																
<small>CADD File Name:</small>																	

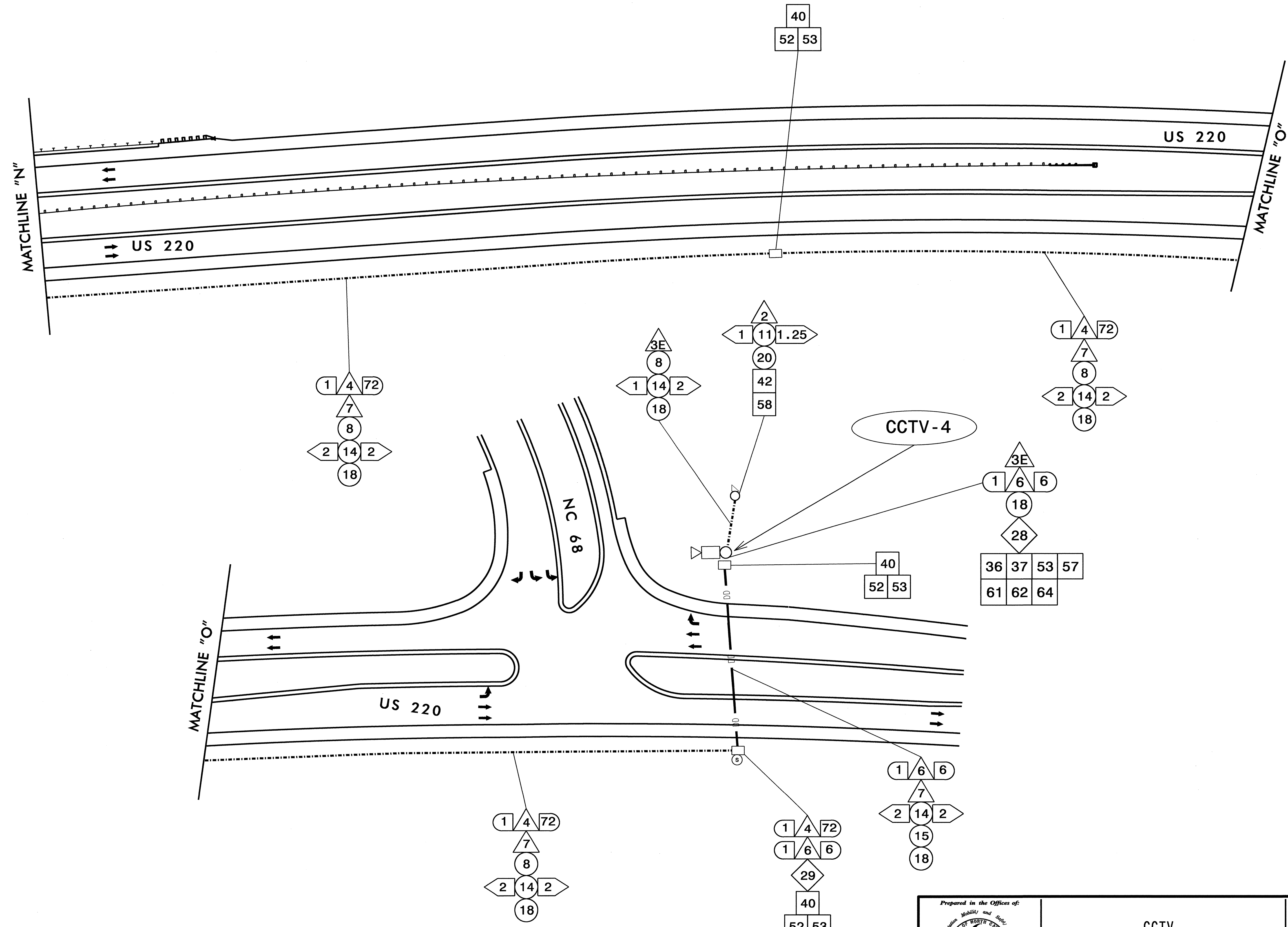

NOTES

1. MAINTAIN A MINIMUM OF SIX (6) FEET FROM EDGE OF PAVEMENT WHEN TRENCHING PARALLEL TO THE ROADWAY. MAXIMUM JUNCTION BOX SPACING 1500' OR AS DIRECTED BY THE ENGINEER.
2. INSTALL CCTV-4 THIRTY (30) FEET FROM US 220 SOUTH BOUND EGDE OF TRAVEL LANE.

	CCTV INSTALLATIONS		
	DIVISION 07 ROCKINGHAM CO.		
	PLAN DATE: SEPTEMBER 2011	REVIEWED BY: M.A. ASLAMI, PE	
PREPARED BY: G.A. GREEN	REVIEWED BY: T.G. PARKER	REVISIONS	INIT. DATE
SCALE: 0 N/A			
		Signature: <i>Gregory A. Fuller</i> DATE: 10/5/11	

**NEW SPLICE ENCLOSURE
US 220 AT HAW RIVER BRIDGE**

SHEET ITS-4

LEGEND

- X = FUSION SPLICE
- E = EXISTING FUSION SPLICE
- C = EXISTING FUSION SPLICE

**COLOR CODE
TIA/EIA 598-A**

- | | |
|------------|-------------|
| (1) BLUE | (7) RED |
| (2) ORANGE | (8) BLACK |
| (3) GREEN | (9) YELLOW |
| (4) BROWN | (10) VIOLET |
| (5) SLATE | (11) ROSE |
| (6) WHITE | (12) AQUA |

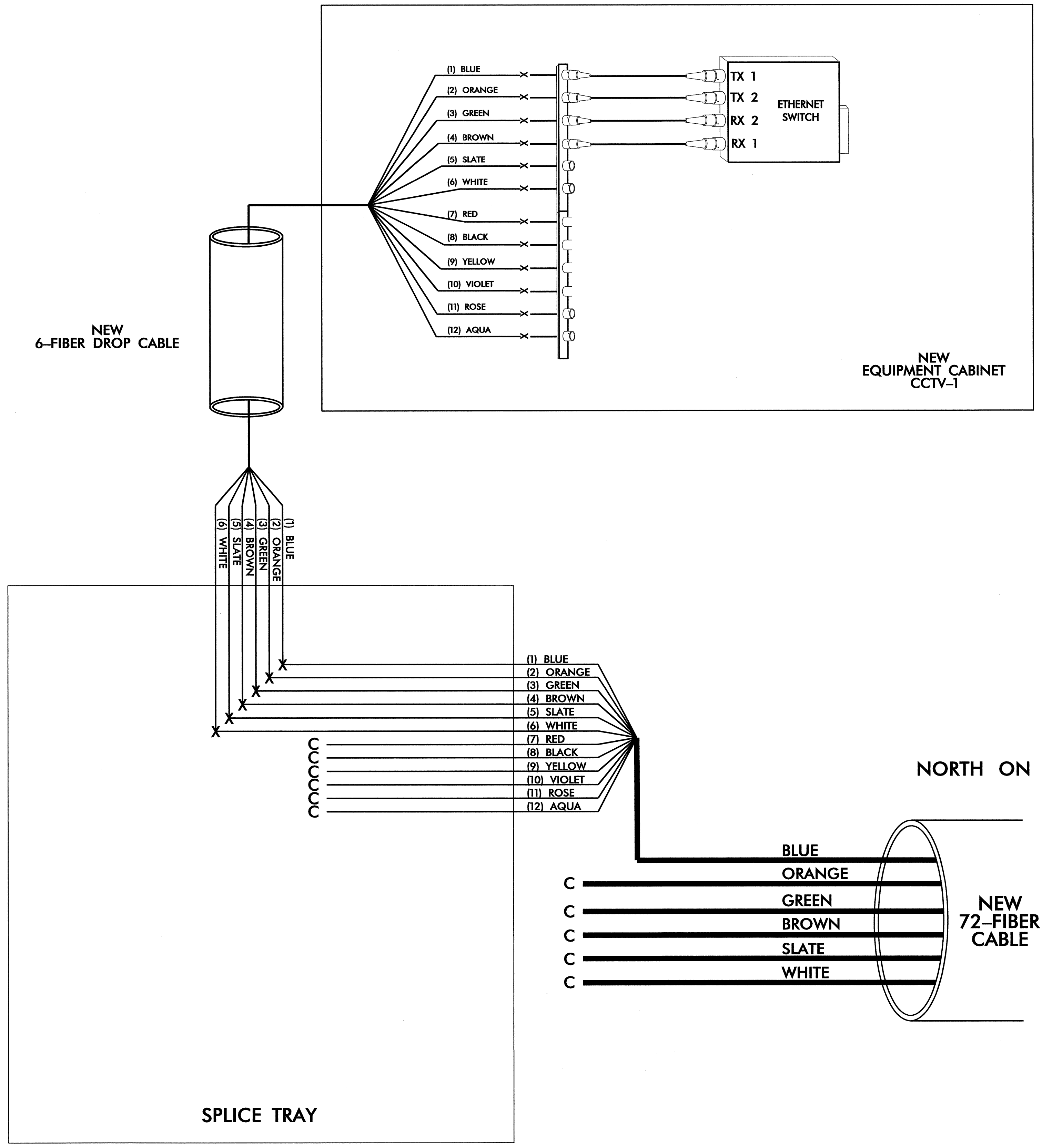

NOTES:

1. COIL AND STORE ALL UNUSED FIBERS IN SPLICE TRAY. CAP UNUSED BUFFER TUBES.
2. ETHERNET SWITCH AND TRANSCEIVER TERMINATION CONFIGURATIONS ARE GENERIC. CONTRACTOR IS RESPONSIBLE FOR DETERMINING/ENSURING PROPER TERMINATION.

	SPLICE DETAILS		SEAL NORTH CAROLINA PROFESSIONAL ENGINEER GREGORY A. FULLER 023919
	DIVISION 07 GUILFORD & ROCKINGHAM CO. PLAN DATE: SEPTEMBER 2011 REVIEWED BY: M.A. ASLAM, PE PREPARED BY: G.A. GREEN REVIEWED BY: T.G. PARKER		

NEW SPLICE ENCLOSURE
US 220 AT US 158
US 220 AT NC 65
SHEETS ITS-6 & ITS-10

LEGEND

- X = FUSION SPLICE
- E = EXISTING FUSION SPLICE
- C = EXISTING FUSION SPLICE

COLOR CODE
TIA/EIA 598-A

- (1) BLUE
- (2) ORANGE
- (3) GREEN
- (4) BROWN
- (5) SLATE
- (6) WHITE
- (7) RED
- (8) BLACK
- (9) YELLOW
- (10) VIOLET
- (11) ROSE
- (12) AQUA

SOUTH ON US 220



BLUE
ORANGE
GREEN
BROWN
SLATE
WHITE

NEW
6-FIBER DROP CABLE

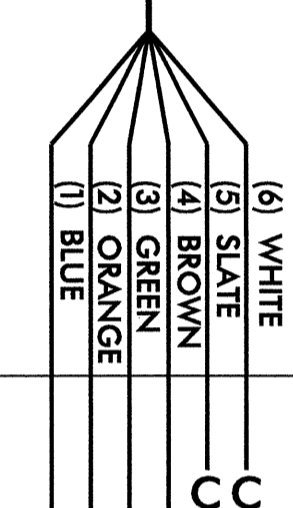
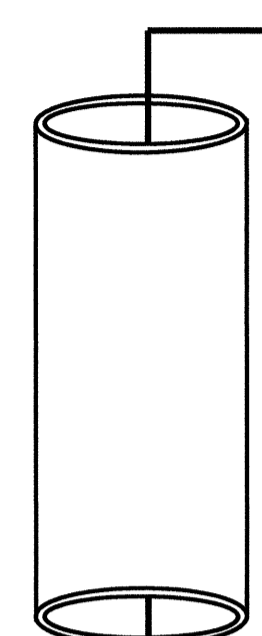

THRU SPLICE ALL FIBERS
THRU SPLICE ALL FIBERS
THRU SPLICE ALL FIBERS
THRU SPLICE ALL FIBERS
THRU SPLICE ALL FIBERS

(1) BLUE
(2) ORANGE
(3) GREEN
(4) BROWN
(5) SLATE
(6) WHITE
(7) RED
(8) BLACK
(9) YELLOW
(10) VIOLET
(11) ROSE
(12) AQUA

NORTH ON US 220

BLUE
ORANGE
GREEN
BROWN
SLATE
WHITE

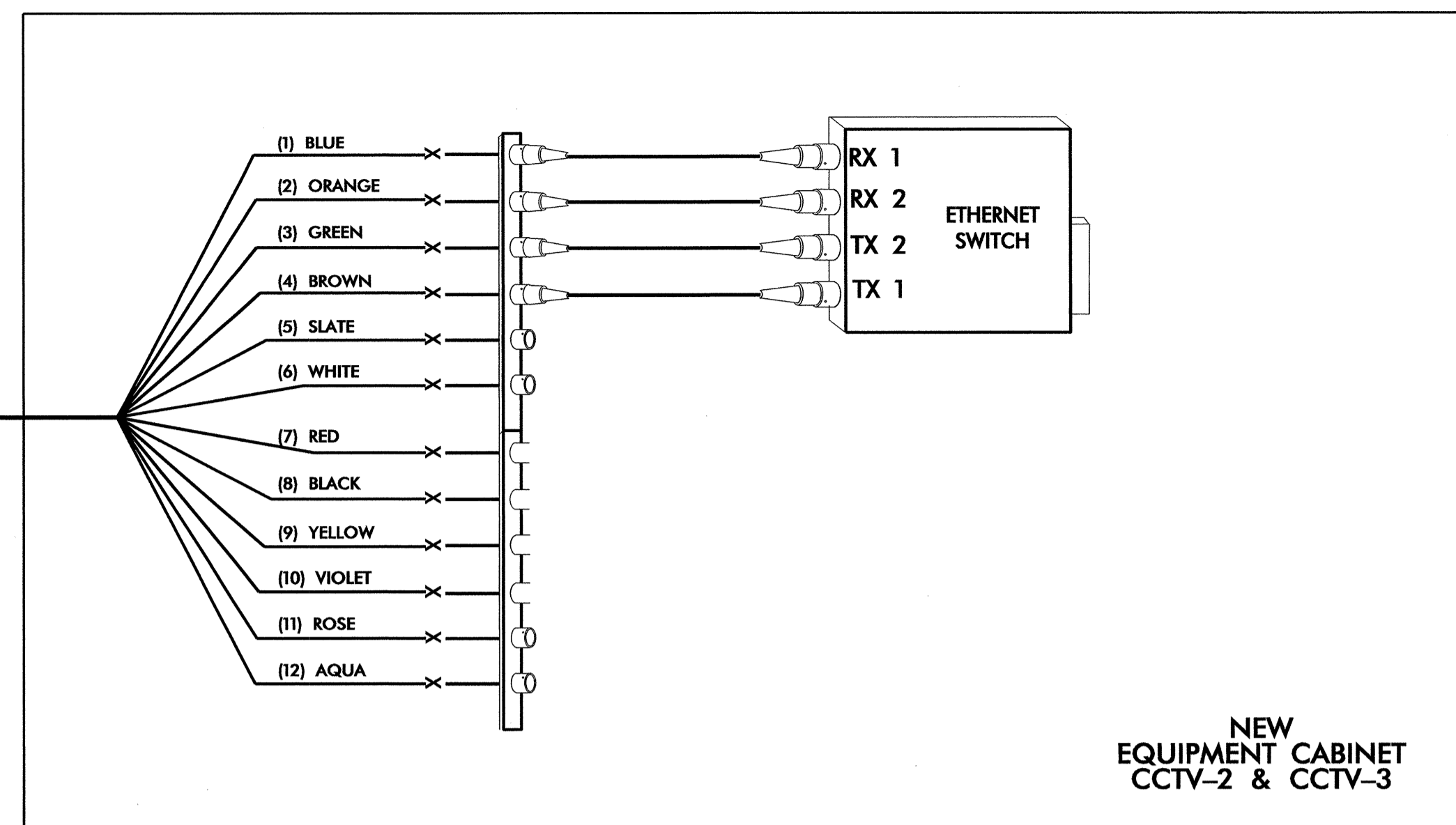
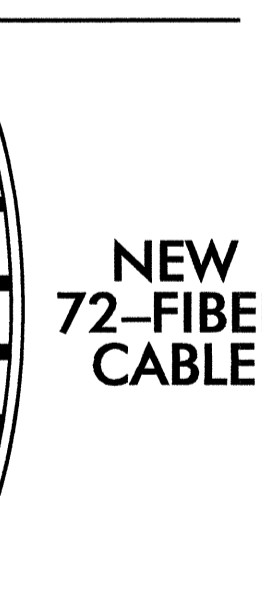

NEW
EQUIPMENT CABINET
CCTV-2 & CCTV-3

SPLICE TRAY

NOTES:

1. COIL AND STORE ALL UNUSED FIBERS IN SPLICE TRAY. CAP UNUSED BUFFER TUBES.
2. ETHERNET SWITCH AND TRANSCEIVER TERMINATION CONFIGURATIONS ARE GENERIC. CONTRACTOR IS RESPONSIBLE FOR DETERMINING/ENSURING PROPER TERMINATION.

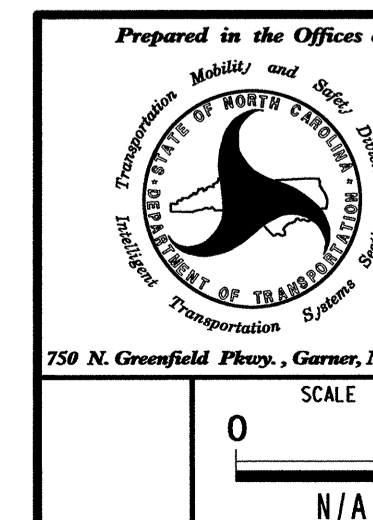

Prepared in the Offices of:
Promotion, Mobility and Safety Division
STATE OF NORTH CAROLINA
Department of Transportation
750 N. Greenfield Pkwy., Garner, NC 27529

SCALE: 0 N/A

SPLICE DETAILS	
REVISIONS	INIT. DATE

SEAL
NORTH CAROLINA
PROFESSIONAL
ENGINEER
GREGORY A. FULLER
023919

Signature: Gregory A. Fuller
Date: 10/5/11

CADD Filename: _____

NEW SPLICE ENCLOSURE
US 220 AT NC 68

SHEET ITS-13

LEGEND

- X = FUSION SPLICE
- E = EXISTING FUSION SPLICE
- C = EXISTING FUSION SPLICE

COLOR CODE
TIA/EIA 598-A

- | | |
|------------|-------------|
| (1) BLUE | (7) RED |
| (2) ORANGE | (8) BLACK |
| (3) GREEN | (9) YELLOW |
| (4) BROWN | (10) VIOLET |
| (5) SLATE | (11) ROSE |
| (6) WHITE | (12) AQUA |

SOUTH ON US 220

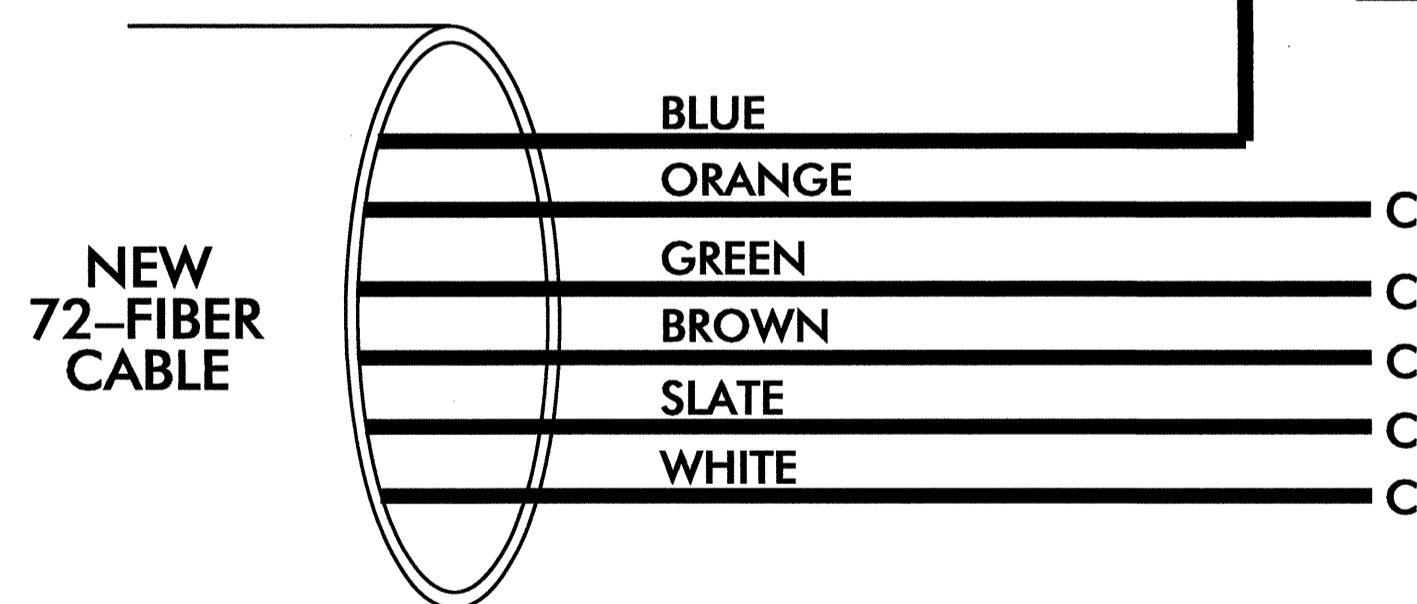

NEW
6-FIBER
DROP CABLE

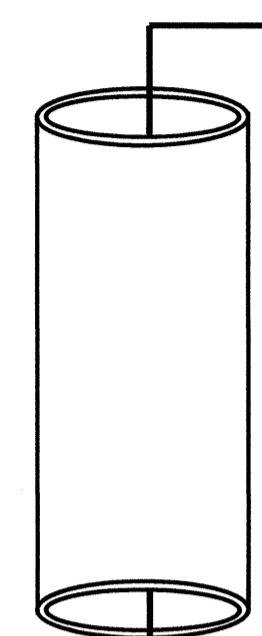

- (1) BLUE
- (2) ORANGE
- (3) GREEN
- (4) BROWN
- (5) SLATE
- (6) WHITE

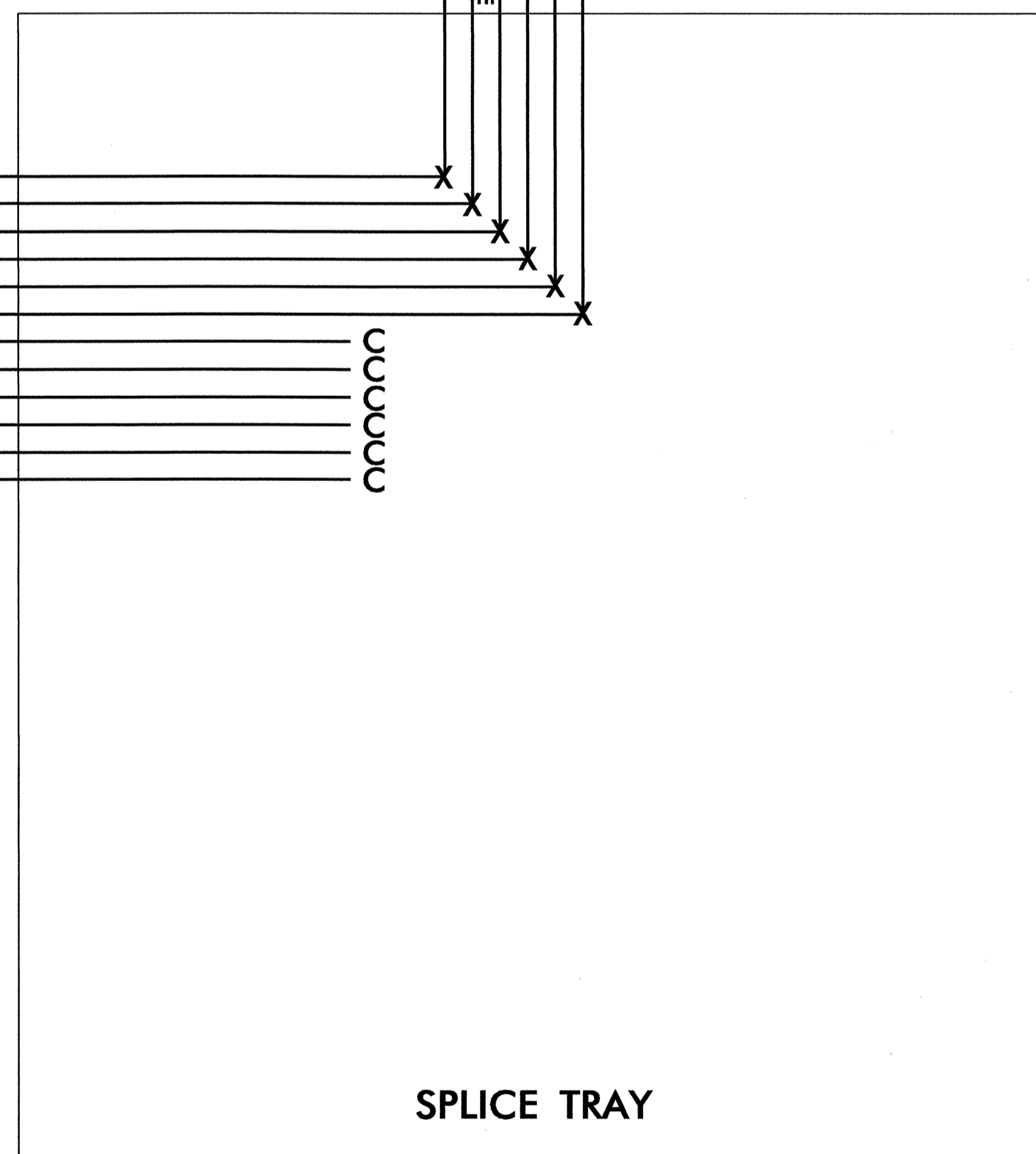

SPLICE TRAY

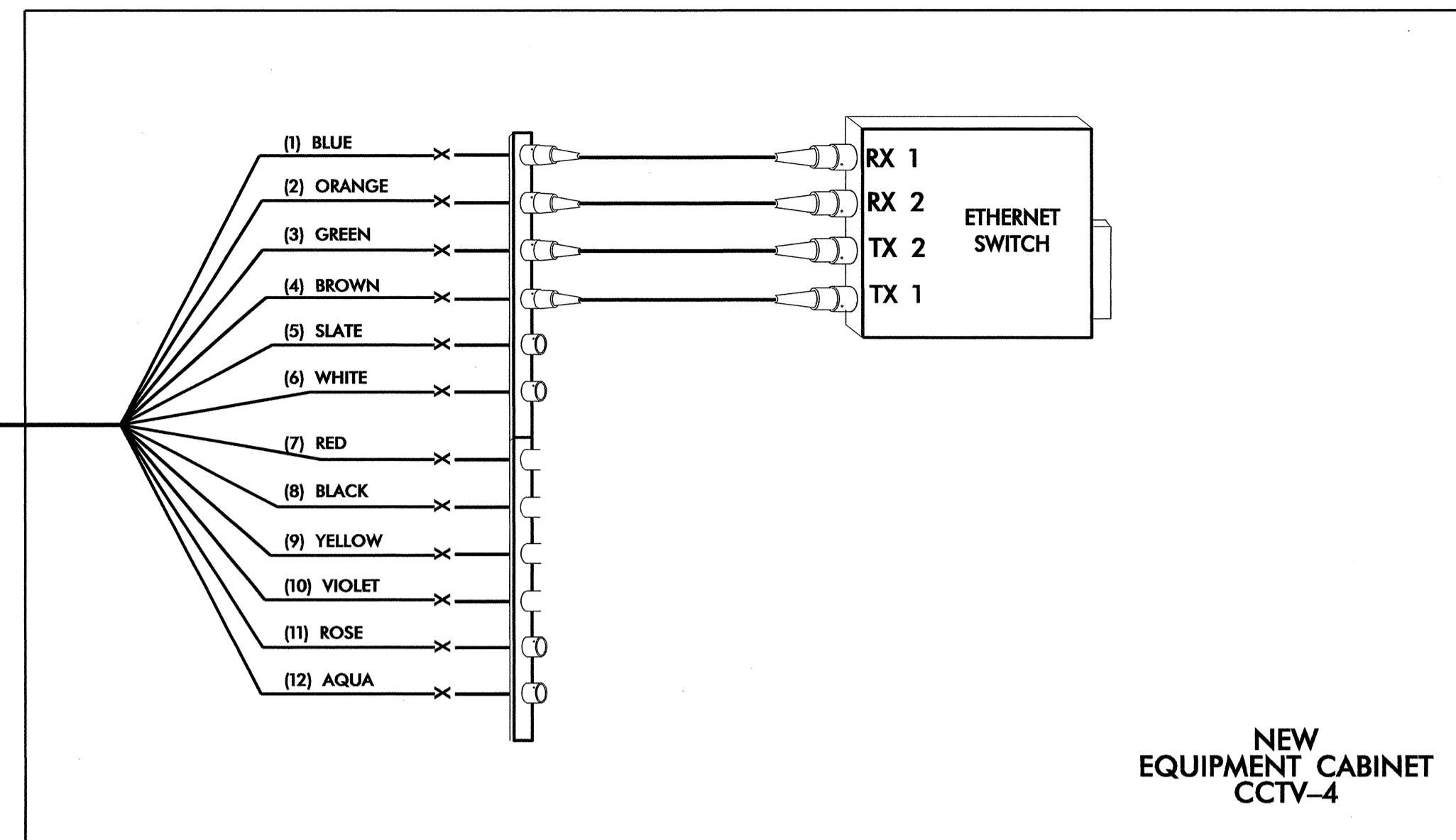

NEW
EQUIPMENT CABINET
CCTV-4

NOTES:

1. COIL AND STORE ALL UNUSED FIBERS IN SPLICE TRAY. CAP UNUSED BUFFER TUBES.
2. ETHERNET SWITCH AND TRANSCEIVER TERMINATION CONFIGURATIONS ARE GENERIC. CONTRACTOR IS RESPONSIBLE FOR DETERMINING/ENSURING PROPER TERMINATION.

	SPLICE DETAILS		
	DIVISION 07 GUILFORD & ROCKINGHAM CO. PLAN DATE: SEPTEMBER 2011 REVIEWED BY: M.A. ASLAMI, PE PREPARED BY: G.A. GREEN REVIEWED BY: T.G. PARKER		
SCALE 0 N/A	REVISIONS _____ _____ _____	INIT. DATE _____ _____ _____ _____	SIGNATURE: <i>Gregory A. Fuller</i> DATE: 10/3/11 CADD Filename: