

TIP PROJECT: B-4416

STATE OF NORTH CAROLINA
 DIVISION OF HIGHWAYS
 PLAN FOR PROPOSED
 HIGHWAY EROSION CONTROL
BEAUFORT COUNTY

**LOCATION: BRIDGE 76 OVER THE CAROLINA &
 NORTHWEST RAILROADS ON NC 33**

TYPE OF WORK: GRADING, DRAINAGE, PAVING, AND STRUCTURE

STATE	STATE PROJECT REFERENCE NO.	SHEET NO.	TOTAL SHEETS
N.C.	B-4416	EC-1	
STATE PROJ. NO.	F.A. PROJ. NO.	DESCRIPTION	

EROSION AND SEDIMENT CONTROL MEASURES

Std. #	Description	Symbol
1630.03	Temporary Silt Ditch.....	TD
1630.05	Temporary Diversion.....	TD
1605.01	Temporary Silt Fence.....	III III III
1606.01	Special Sediment Control Fence.....	△△△△△
1622.01	Temporary Berms and Slope Drains.....	T
	Silt Basin Type B.....	□
1633.01	Temporary Rock Silt Check Type-A.....	⊗
	Temporary Rock Silt Check Type-A with Matting and Polyacrylamide (PAM).....	⊗
	Temporary Rock Silt Check Type-B.....	▶
	Wattle / Coir Fiber Wattle.....	⌒
	Wattle / Coir Fiber Wattle with Polyacrylamide (PAM).....	⌒
1634.01	Temporary Rock Sediment Dam Type-A.....	⊞
1634.02	Temporary Rock Sediment Dam Type-B.....	⊞
1635.01	Rock Pipe Inlet Sediment Trap Type-A.....	⊞
1635.02	Rock Pipe Inlet Sediment Trap Type-B.....	⊞
1630.04	Stilling Basin.....	□
1630.06	Special Stilling Basin.....	□
	Rock Inlet Sediment Trap:	
1632.01	Type A.....	A
1632.02	Type B.....	B
1632.03	Type C.....	C
	Skimmer Basin.....	□
	Tiered Skimmer Basin.....	□
	Infiltration Basin.....	□

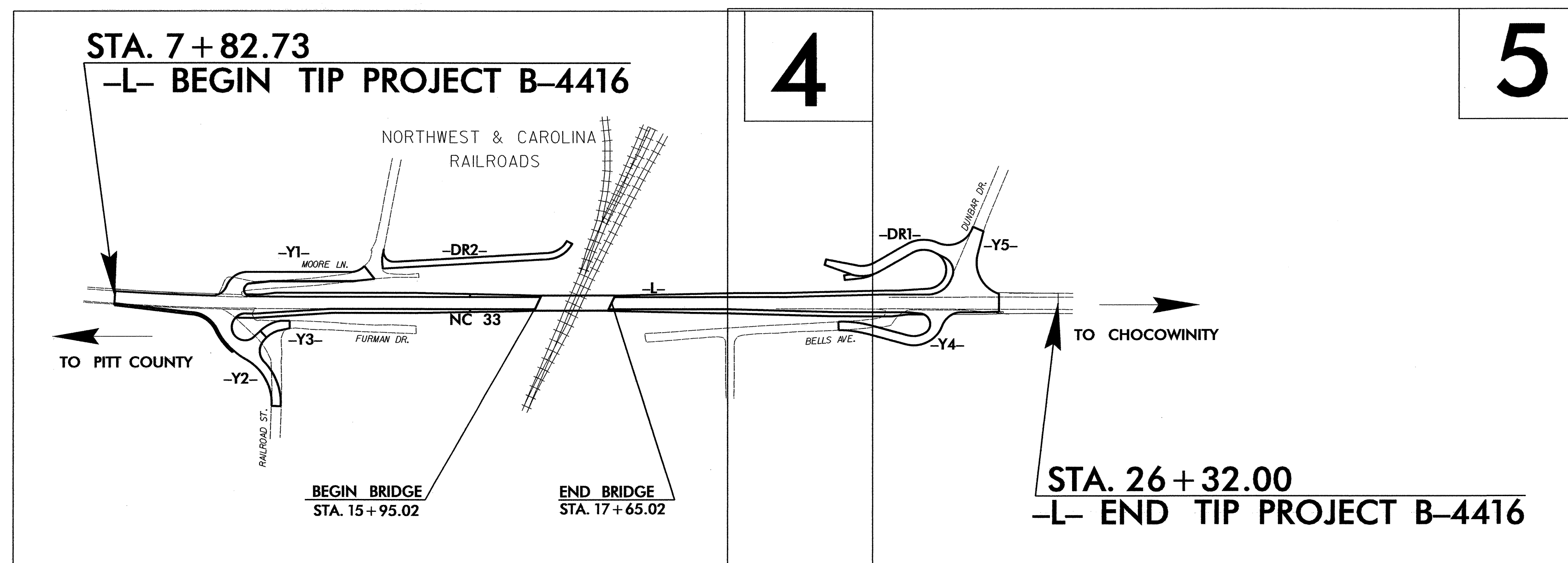
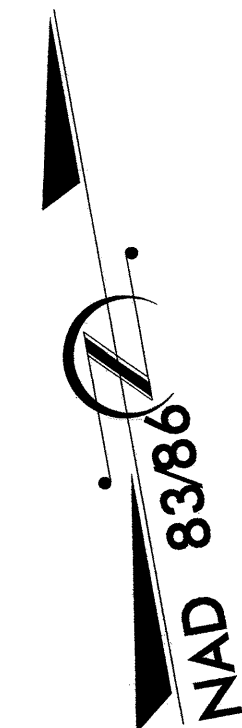

**THIS PROJECT CONTAINS
 EROSION CONTROL PLANS
 FOR CLEARING AND
 GRUBBING PHASE OF
 CONSTRUCTION.**

**THIS PROJECT HAS
 BEEN DESIGNED TO
 SENSITIVE WATERSHED
 STANDARDS.**

GRAPHIC SCALE

0

 PLANS

0

 PROFILE (HORIZONTAL)

0

 PROFILE (VERTICAL)

ROADSIDE ENVIRONMENTAL UNIT
 DIVISION OF HIGHWAYS
 STATE OF NORTH CAROLINA

Prepared In the Office of:
ROADSIDE ENVIRONMENTAL UNIT
 1 South Wilmington St.
 Raleigh, NC 27611
2006 STANDARD SPECIFICATIONS

Roadway Standard Drawings

The following roadway english standards as appear in "Roadway Standard Drawings"- Roadway Design Unit - N. C. Department of Transportation - Raleigh, N. C., dated July 18, 2006 and the latest revision thereto are applicable to this project and by reference hereby are considered a part of these plans.

1605.01 Temporary Silt Fence	1630.05 Temporary Diversion
1606.01 Special Sediment Control Fence	1632.02 Rock Inlet Sediment Trap Type B
1607.01 Gravel Construction Entrance	1632.03 Rock Inlet Sediment Trap Type C
1622.01 Temporary Berms and Slope Drains	1633.01 Temporary Rock Silt Check Type A
1630.03 Temporary Silt Ditch	1635.02 Rock Pipe Inlet Sediment Trap Type B

25-JUL-2011 13:27
 R:\ENR\10\PROJECTS\B4416\EC.tah.dgn
 n:\pib

PROJECT REFERENCE NO. B-4416	SHEET NO. EC-2
RW SHEET NO.	
ROADWAY DESIGN ENGINEER	HYDRAULICS ENGINEER

TEMPORARY ROCK SILT CHECK TYPE 'B' DETAIL

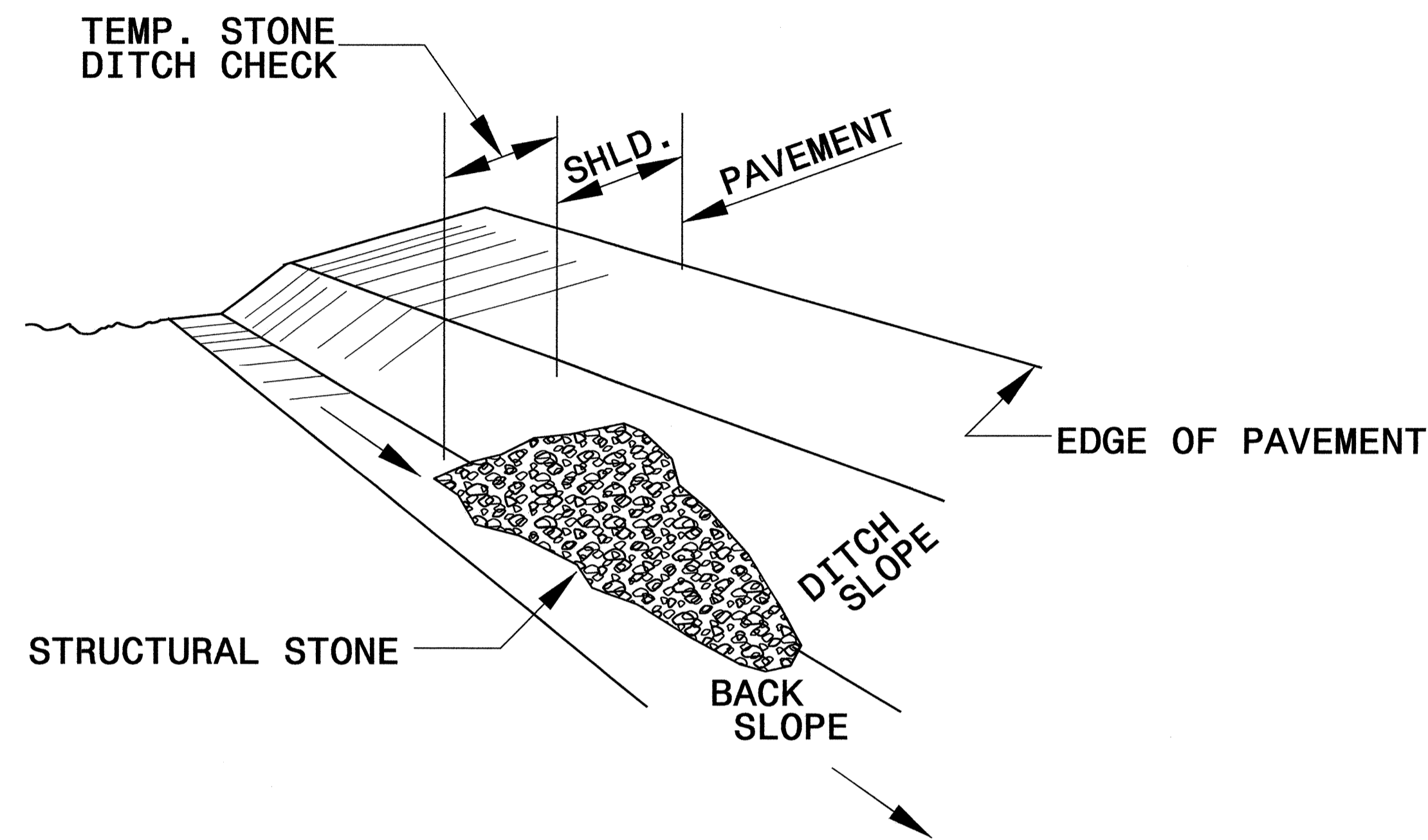

ISOMETRIC VIEW

NOTES:

USE CLASS 'B' EROSION CONTROL STONE FOR STRUCTURAL STONE.

THE ENGINEER MAY DIRECT THE OPTION OF CLASS "A" STONE FOR SITES HAVING LESS THAN ONE (1) ACRE DRAINAGE AREA AND A DITCH GRADE LESS THAN 3%.

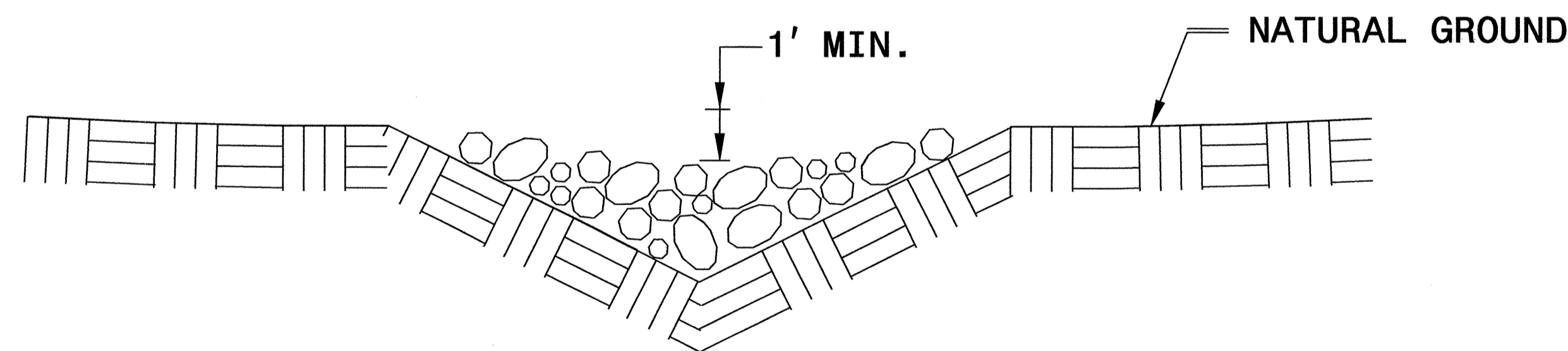

**CROSS SECTION
VEE DITCH**

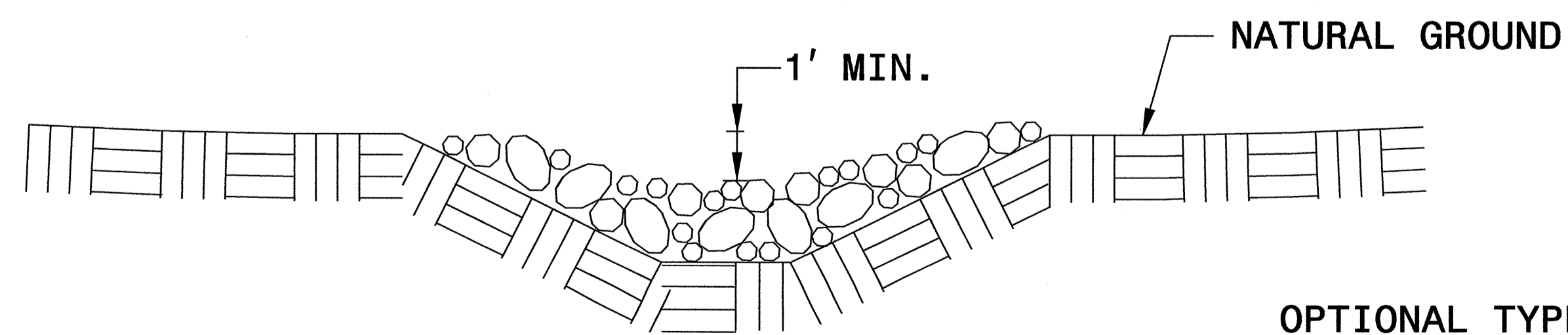

**CROSS SECTION
TRAPEZOIDAL DITCH**

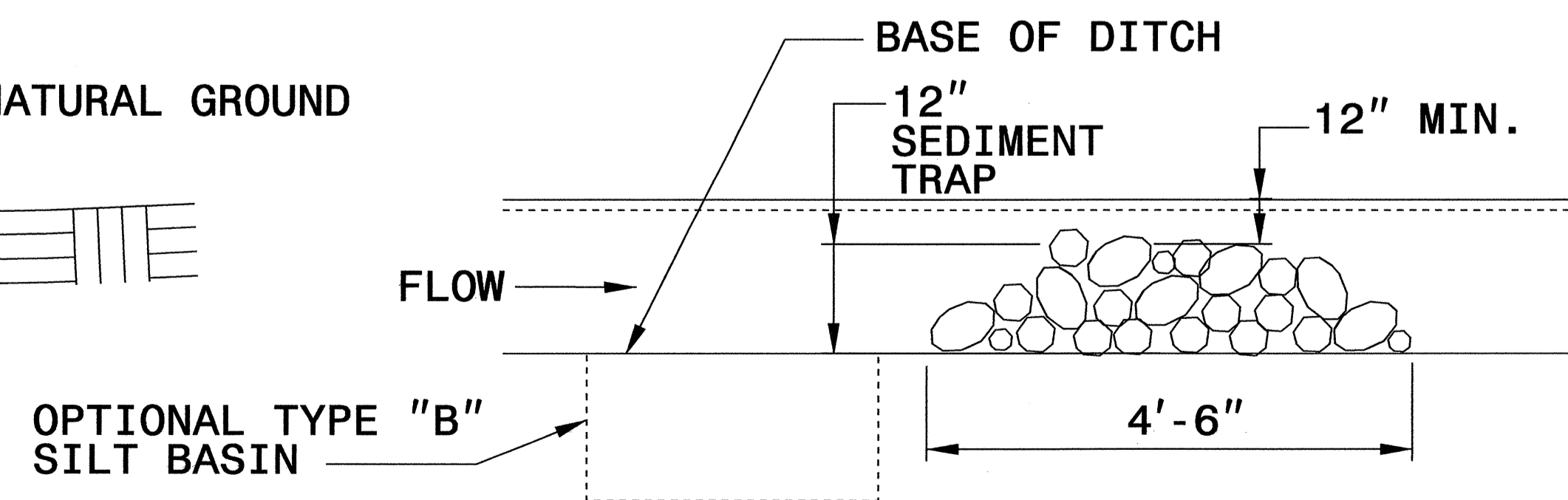

ELEVATION VIEW

PROJECT REFERENCE NO. B-4416	SHEET NO. EC-2A
RW SHEET NO.	
ROADWAY DESIGN ENGINEER	HYDRAULICS ENGINEER

COIR FIBER BAFFLE DETAIL

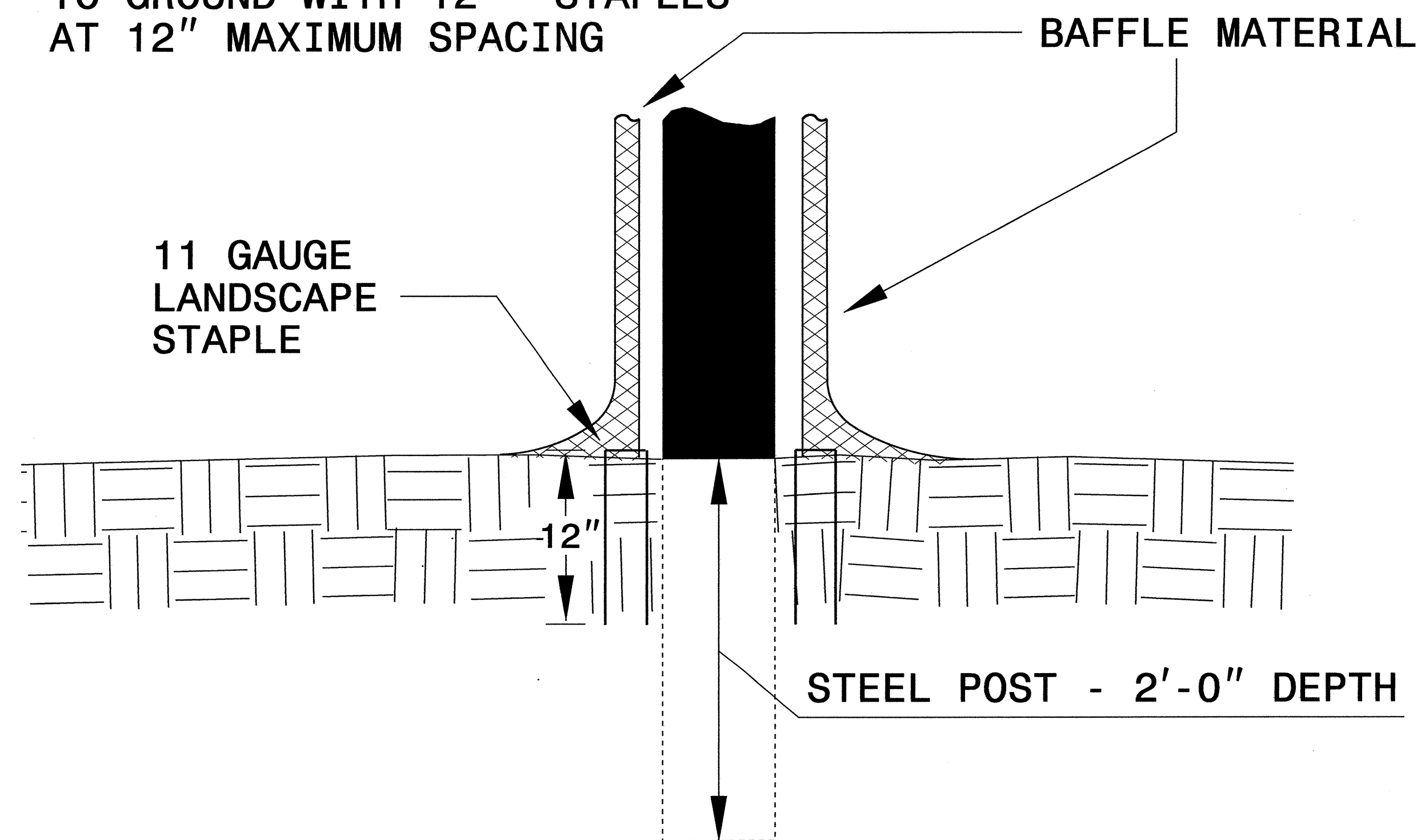
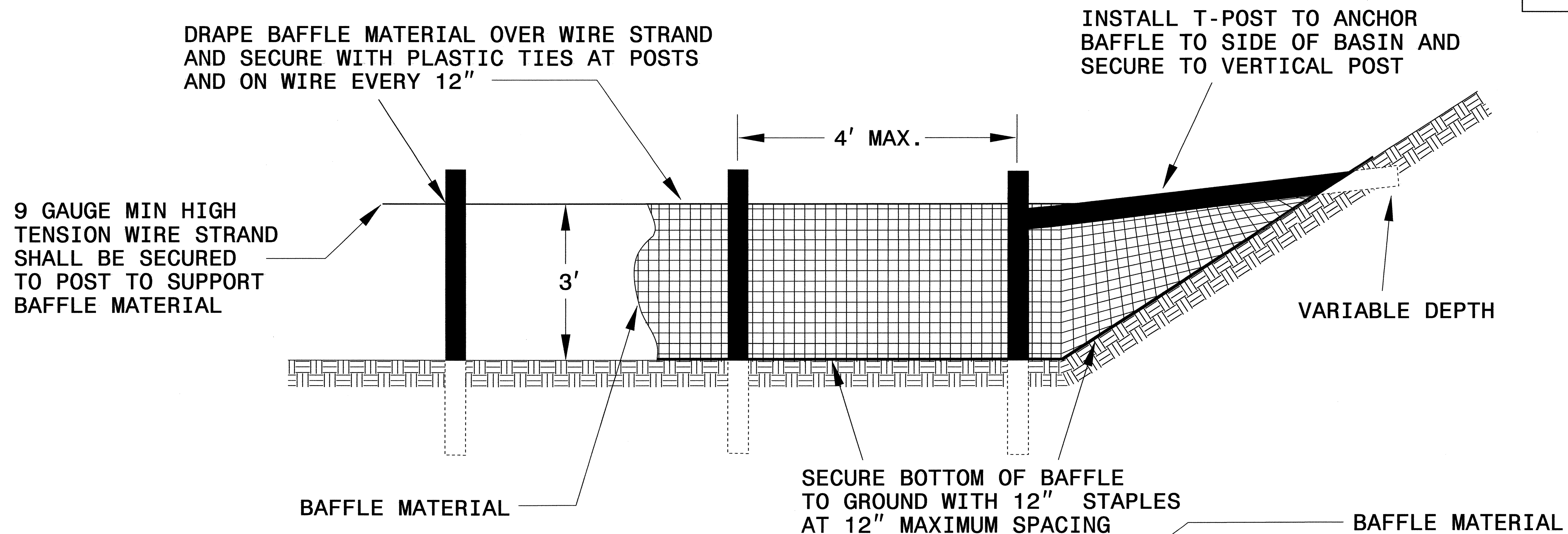

NOTES:

1. INSTALL THREE(3) COIR FIBER BAFFLES IN SILT BASINS AND SEDIMENT DAMS AT DRAINAGE OUTLETS WITH A SPACING OF $\frac{1}{4}$ THE BASIN LENGTH.
2. TWO(2) COIR FIBER BAFFLES CAN BE INSTALLED IN SILT BASINS AND DAMS LESS THAN 20 FT. IN LENGTH WITH A SPACING OF $\frac{1}{3}$ THE BASIN LENGTH.
3. TOP HEIGHT OF COIR FIBER BAFFLES SHALL NOT BE BELOW BASE OF EMERGENCY SPILLWAY ELEVATION.

BAFFLE MATERIAL SHALL BE SECURED TO THE BOTTOM AND SIDES OF BASIN USING 12" LANDSCAPE STAPLES

PROJECT REFERENCE NO. B-4416	SHEET NO. EC-2B
RW SHEET NO.	
ROADWAY DESIGN ENGINEER	HYDRAULICS ENGINEER

SKIMMER BASIN WITH BAFFLES DETAIL

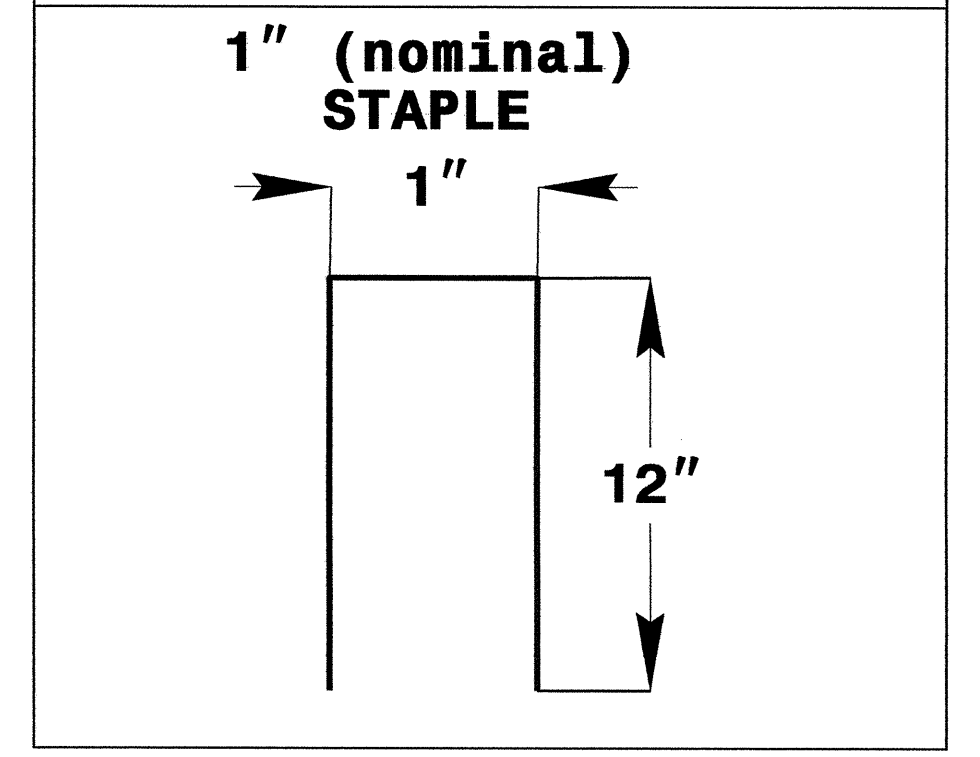
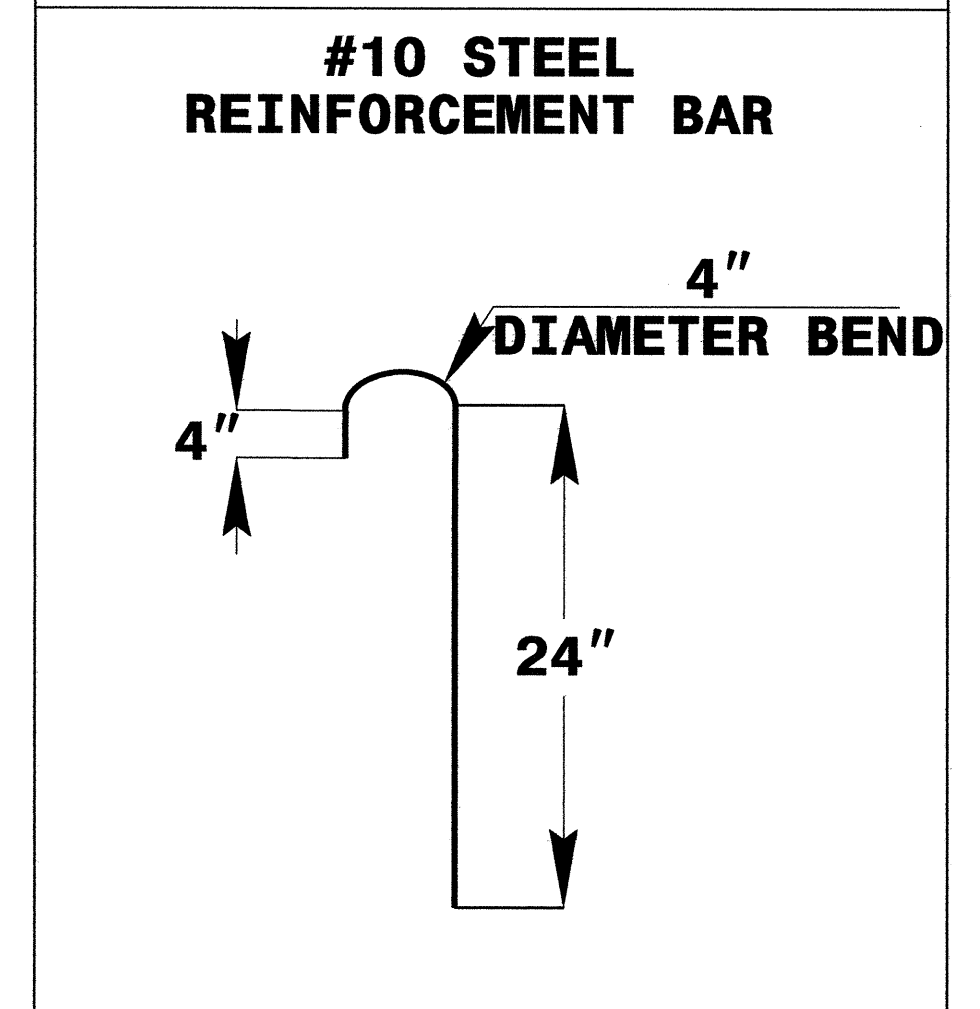
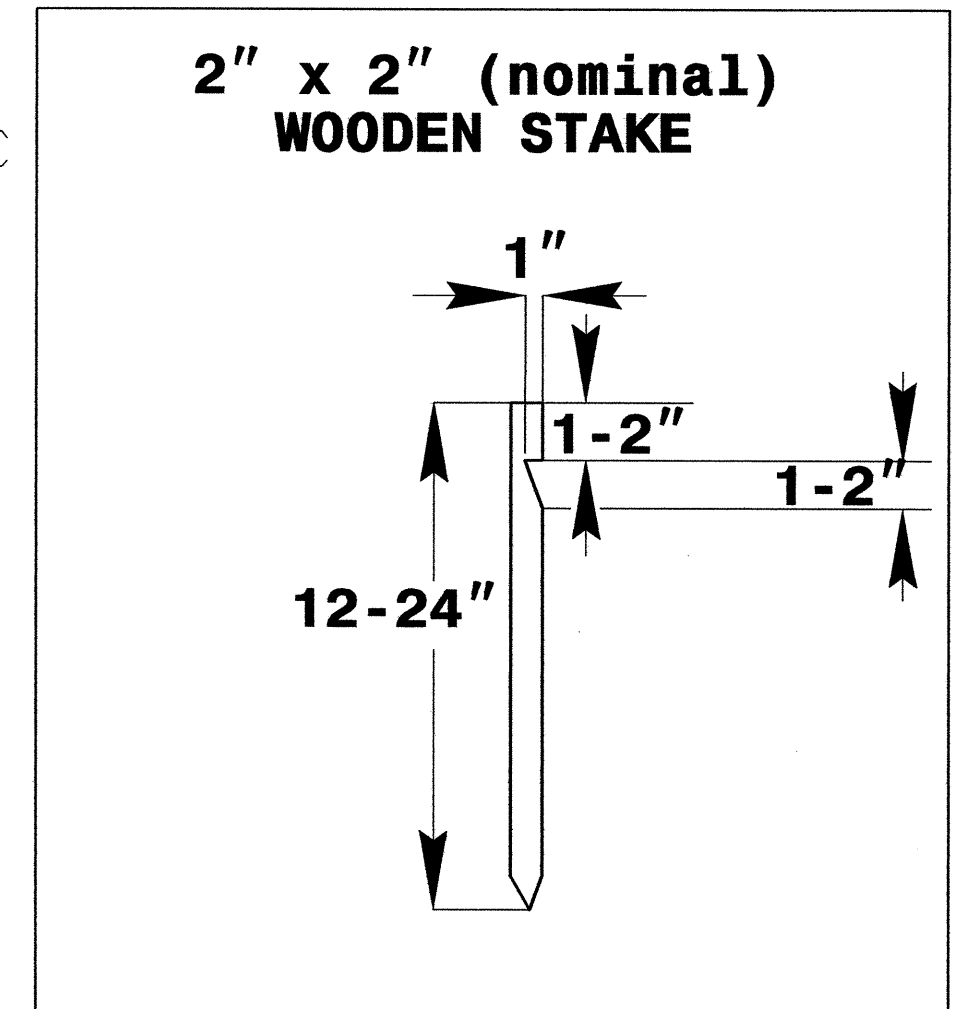
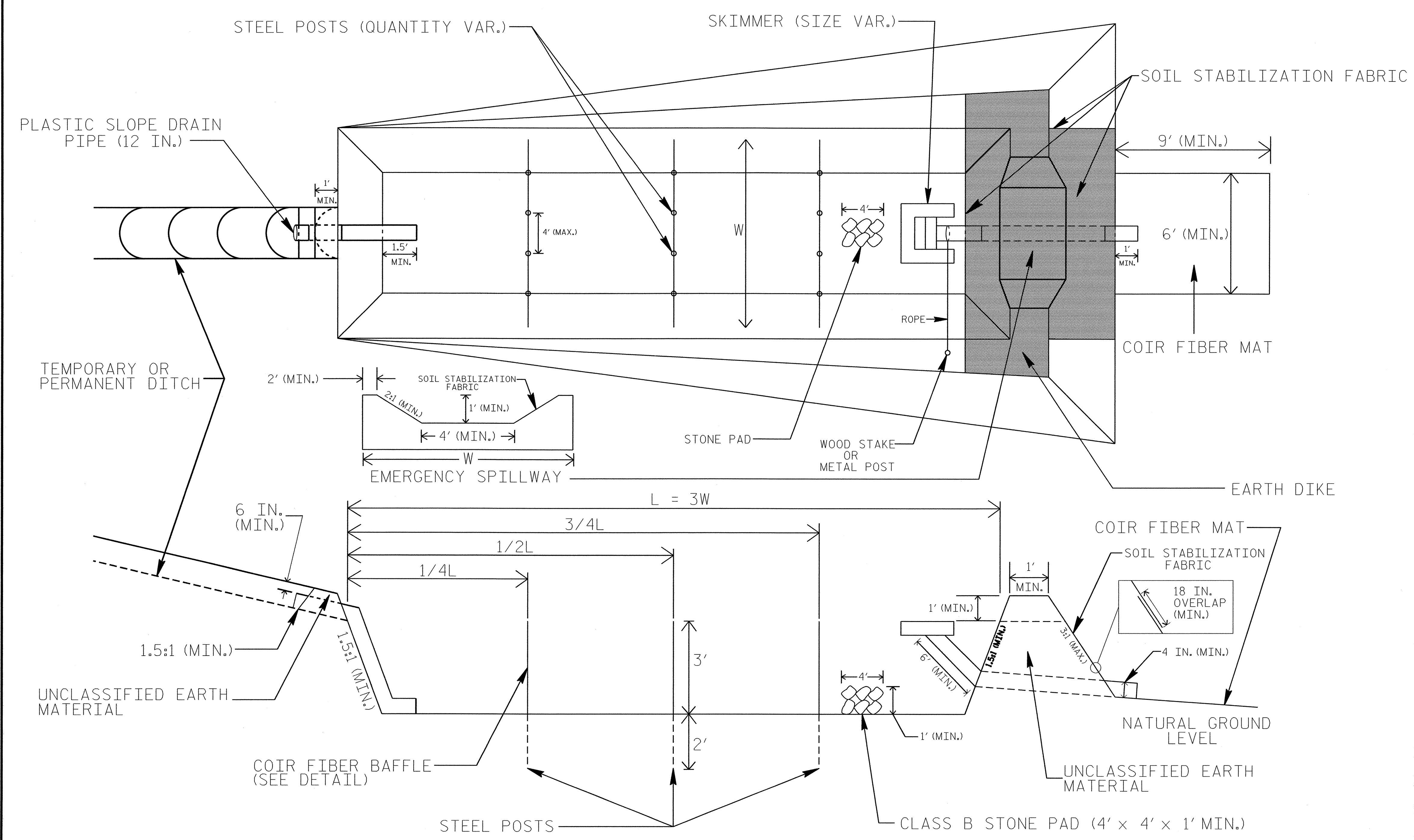

COIR FIBER MAT ANCHOR OPTIONS

NOTES

1. SEED AND PLACE MATTING FOR EROSION CONTROL ON INTERIOR AND EXTERIOR SIDESLOPES.
2. LIMIT EARTH DIKE HEIGHT TO 5 FT.
3. FOR BASIN DEPTH OF 3 FT., THE MINIMUM BASIN WIDTH SHALL BE 9 FT.
4. DETERMINE EMERGENCY SPILLWAY LENGTH (FT.) USING $Q/0.8$, WHERE Q IS FLOW RATE (CFS) INTO BASIN.
5. PLASTIC SLOPE DRAIN PIPE AT INLET OF BASIN MAY BE REPLACED BY FILTER FABRIC AS DIRECTED.
6. SOIL STABILIZATION FABRIC FOR EMERGENCY SPILLWAY SHALL BE ONE CONTINUOUS PIECE OF MATERIAL OR OVERLAPPED 18 IN. (MIN.).

NOT TO SCALE

PROJECT REFERENCE NO. B-4416	SHEET NO. EC-2C
RW SHEET NO.	
ROADWAY DESIGN ENGINEER	HYDRAULICS ENGINEER

WATTLE WITH POLYACRYLAMIDE (PAM) DETAIL

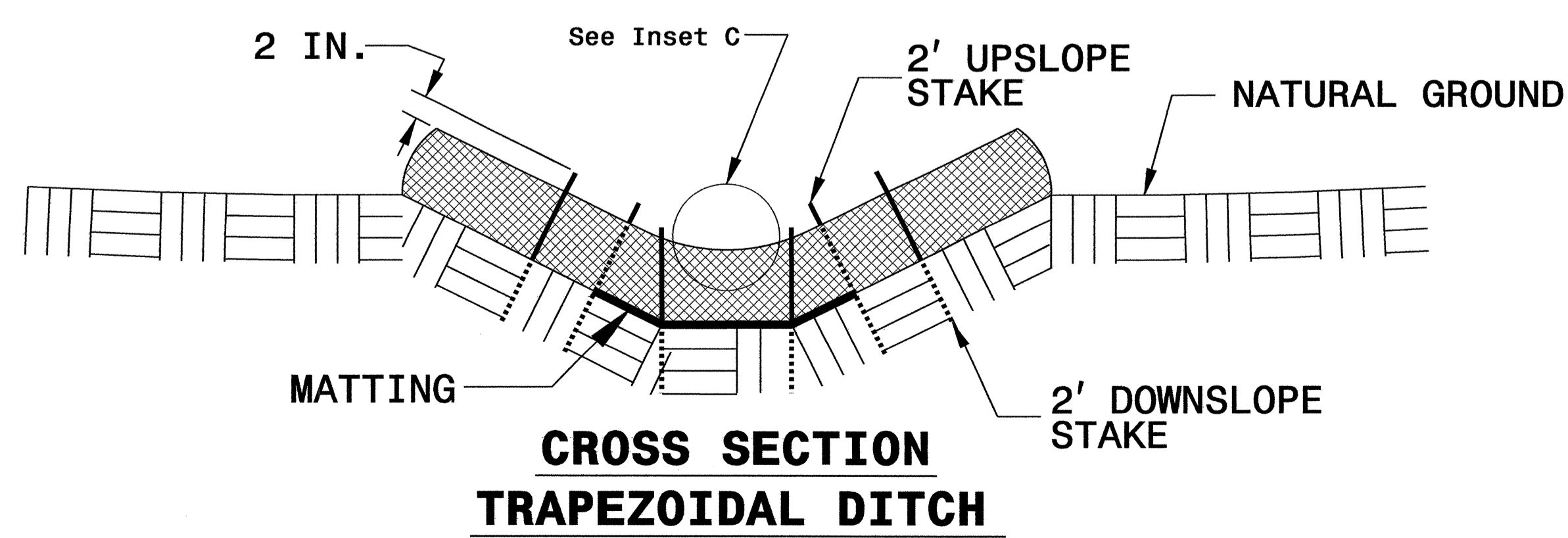
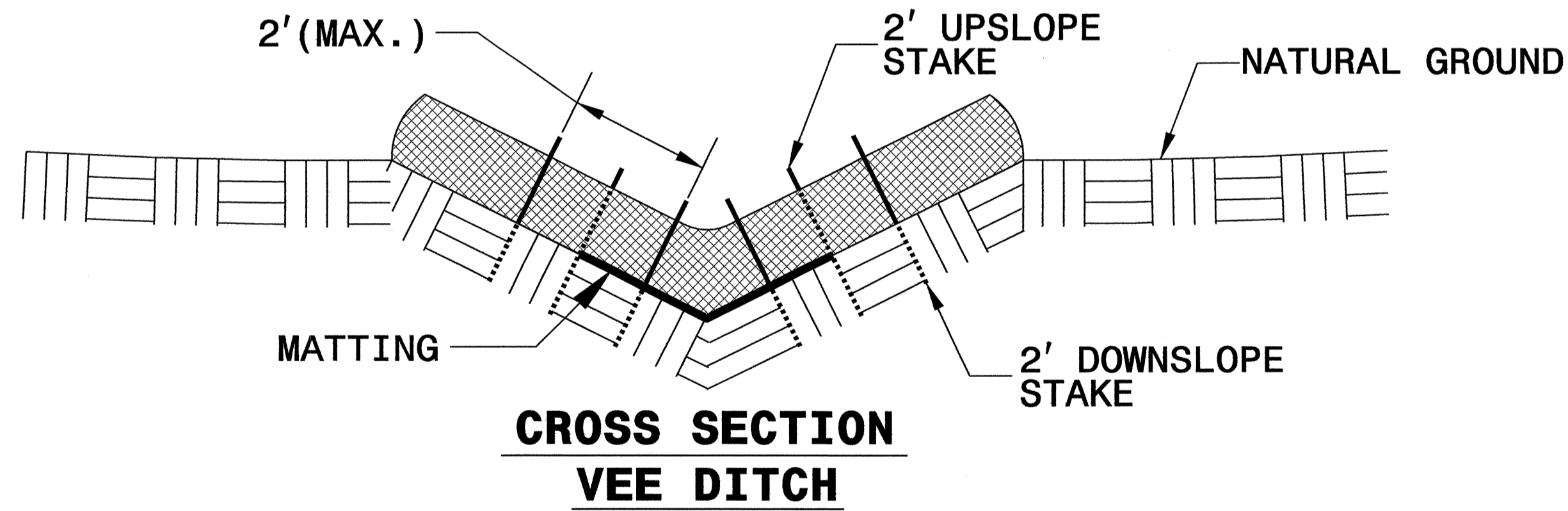
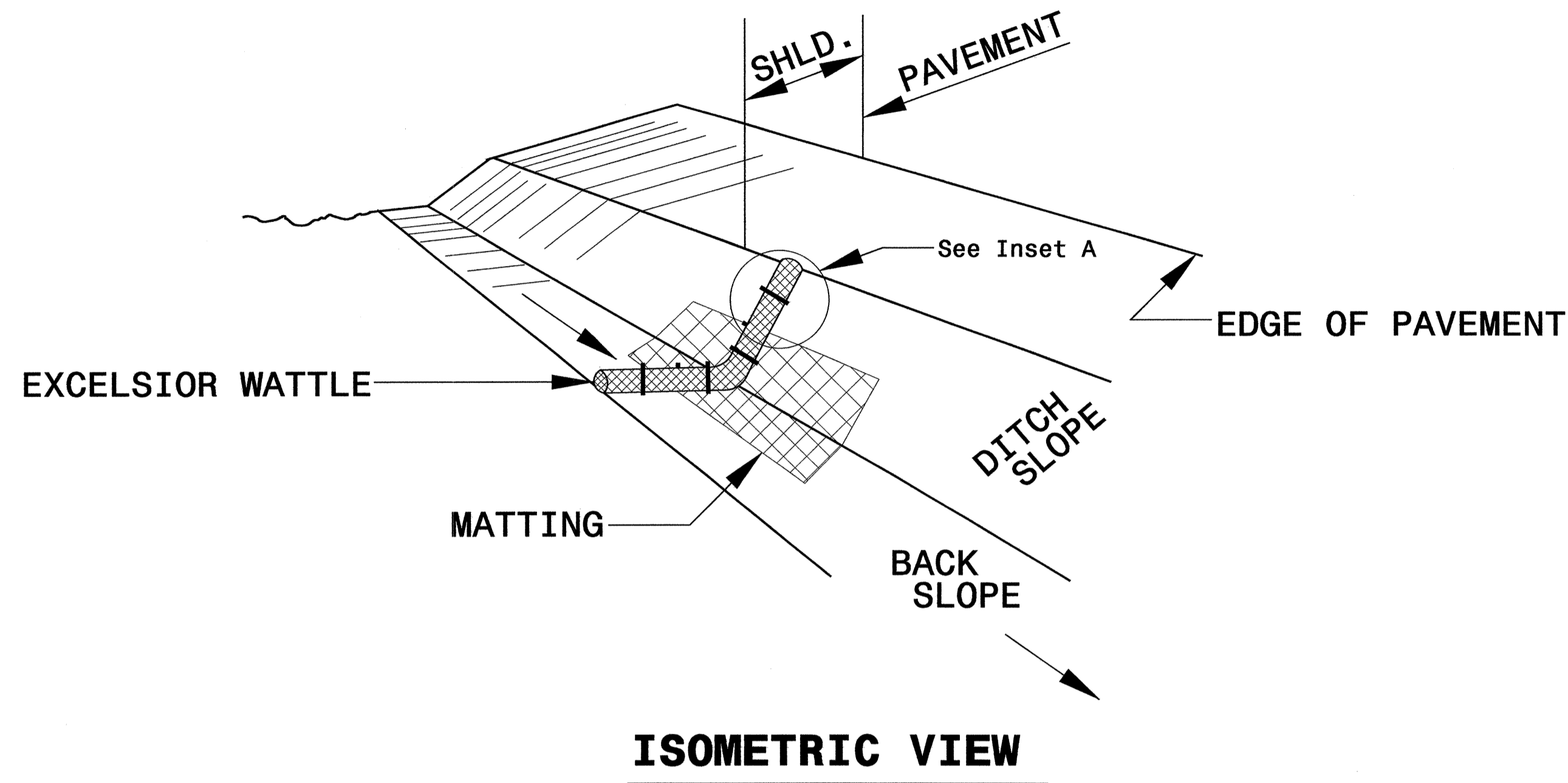

- NOTES:
- USE MINIMUM 12 IN. DIAMETER EXCELSIOR WATTLE.
 - USE 2 FT. WOODEN STAKES WITH A 2 IN. BY 2 IN. NOMINAL CROSS SECTION.
 - ONLY INSTALL WATTLE(S) TO A HEIGHT IN DITCH SO FLOW WILL NOT WASH AROUND WATTLE AND SCOUR DITCH SLOPES AND AS DIRECTED.
 - INSTALL A MINIMUM OF 2 UPSLOPE STAKES AND 4 DOWNSLOPE STAKES AT AN ANGLE TO WEDGE WATTLE TO BOTTOM OF DITCH.
 - PROVIDE STAPLES MADE OF 0.125 IN. DIAMETER STEEL WIRE FORMED INTO A U SHAPE NOT LESS THAN 12" IN LENGTH.
 - INSTALL STAPLES APPROXIMATELY EVERY 1 LINEAR FOOT ON BOTH SIDES OF WATTLE AND AT EACH END TO SECURE IT TO THE SOIL.
 - INSTALL MATTING IN ACCORDANCE WITH SECTION 1631 OF THE STANDARD SPECIFICATIONS.
 - PRIOR TO POLYACRYLAMIDE (PAM) APPLICATION, OBTAIN A SOIL SAMPLE FROM PROJECT LOCATION, AND FROM OFFSITE MATERIAL, AND ANALYZE FOR APPROPRIATE PAM FLOCCULANT TO BE APPLIED TO EACH WATTLE.
 - INITIALLY APPLY 2 OUNCES OF ANIONIC OR NEUTRALLY CHARGED PAM OVER WATTLE WHERE WATER WILL FLOW AND 1 OUNCE OF PAM ON EACH SIDE OF WATTLE. REAPPLY PAM AFTER EVERY RAINFALL EVENT THAT IS EQUAL TO OR EXCEEDS 0.50 IN.

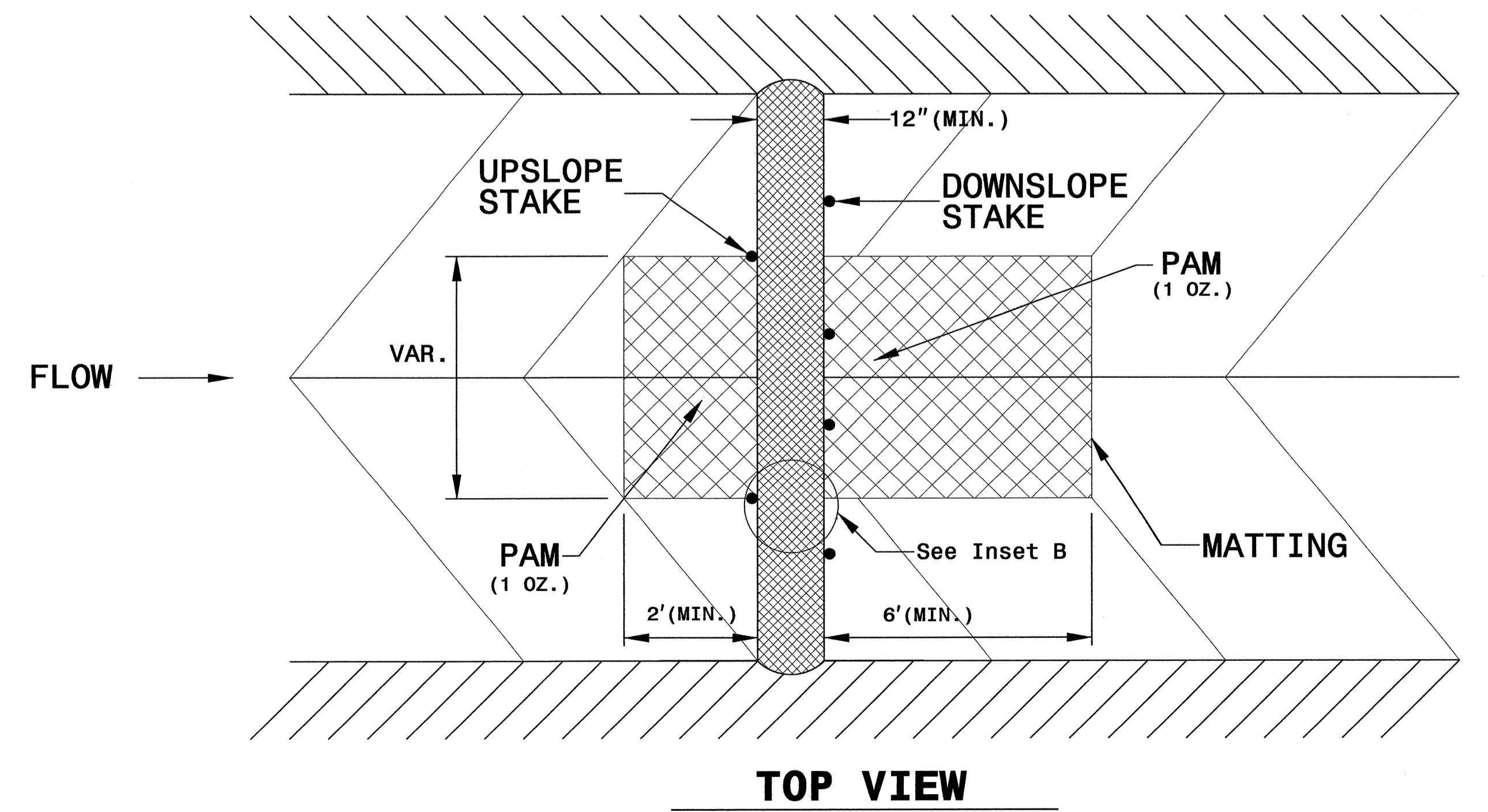
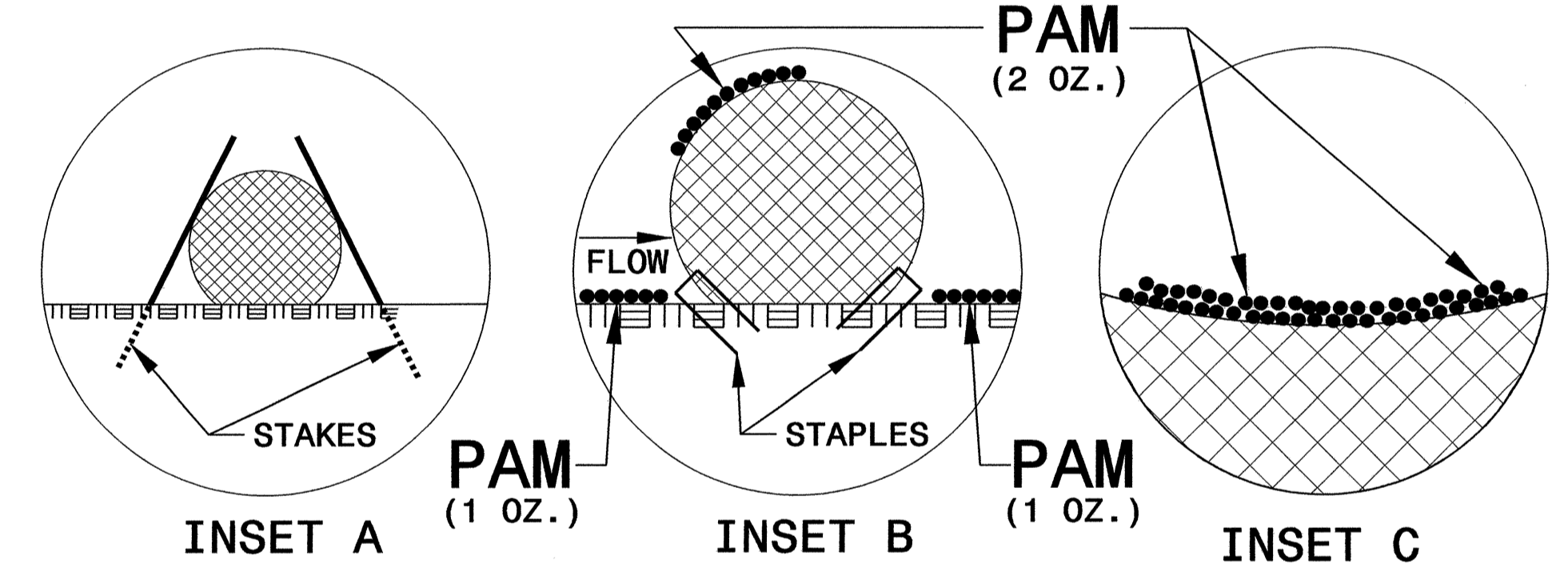

PROJECT REFERENCE NO. B-4416	SHEET NO. EC-2D
RW SHEET NO.	
ROADWAY DESIGN ENGINEER	HYDRAULICS ENGINEER

TEMPORARY ROCK SILT CHECK TYPE 'A' WITH EXCELSIOR MATTING AND POLYACRYLAMIDE (PAM)

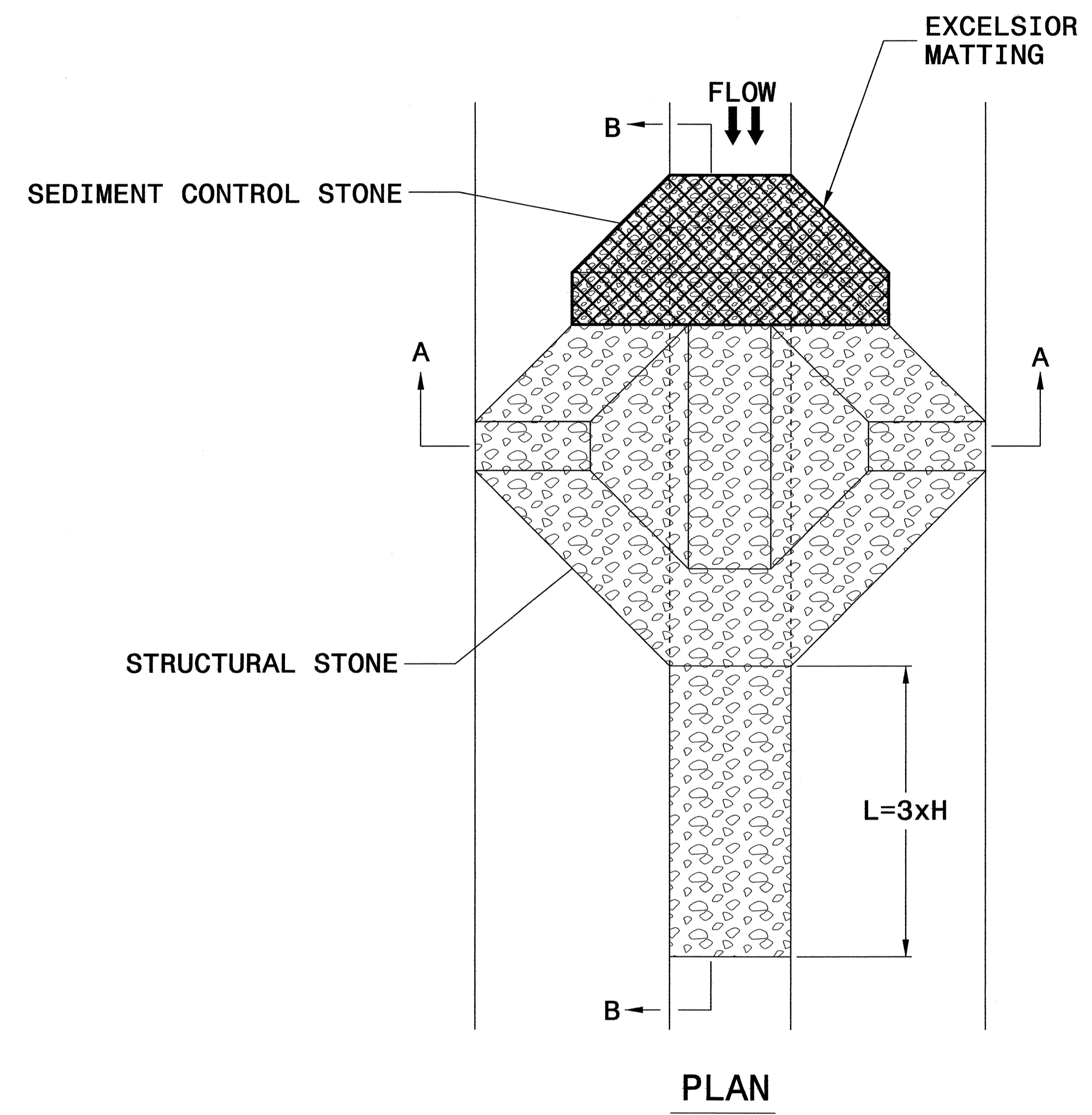

NOTES

USE EXCELSIOR FOR MATTING MATERIAL AND ANCHOR MATTING SECTION AT TOP AND BOTTOM WITH CLASS B STONE.

PRIOR TO POLYACRYLAMIDE (PAM) APPLICATION, OBTAIN A SOIL SAMPLE FROM PROJECT LOCATION, AND FROM OFFSITE MATERIAL, AND ANALYZE FOR APPROPRIATE PAM FLOCCULANT TO BE APPLIED TO EACH ROCK SILT CHECK.

INITIALLY APPLY 3.5 OUNCES OF POLYACRYLAMIDE (PAM) TO TOP OF MATTING SECTION AND AFTER EVERY RAINFALL EVENT THAT EQUALS OR EXCEEDS 0.50 INCHES.

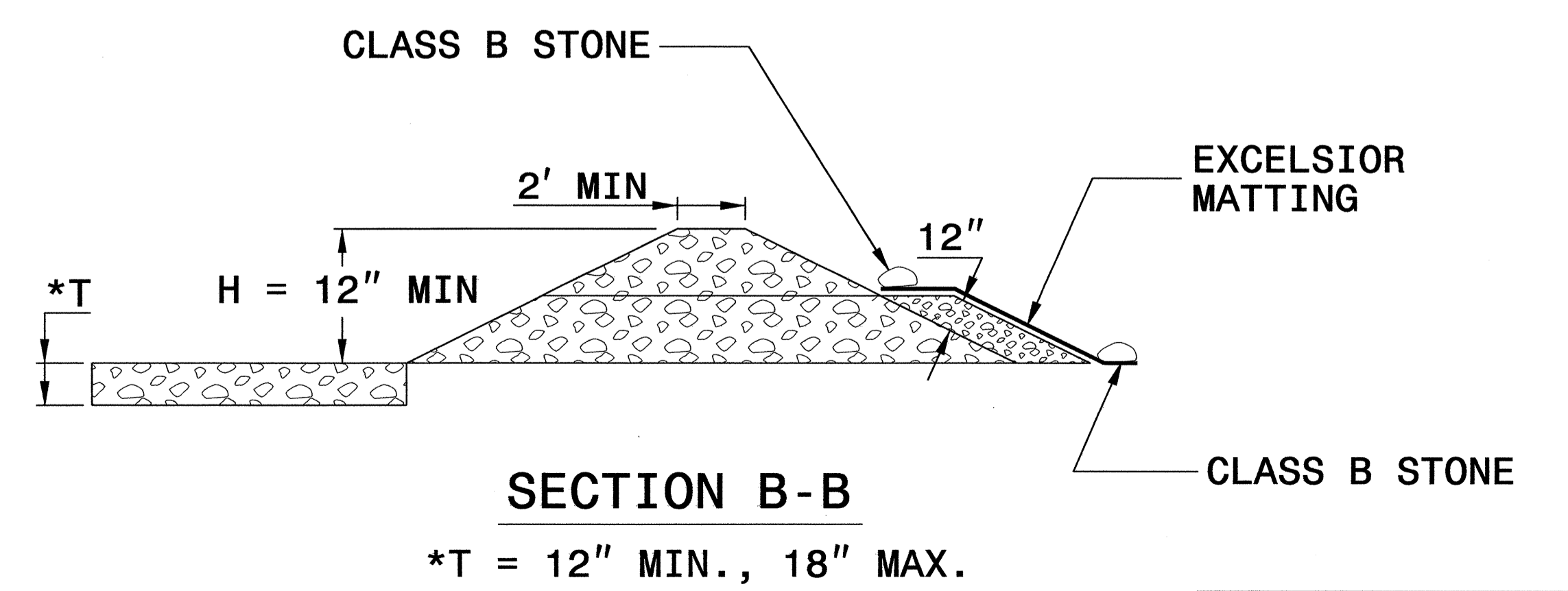
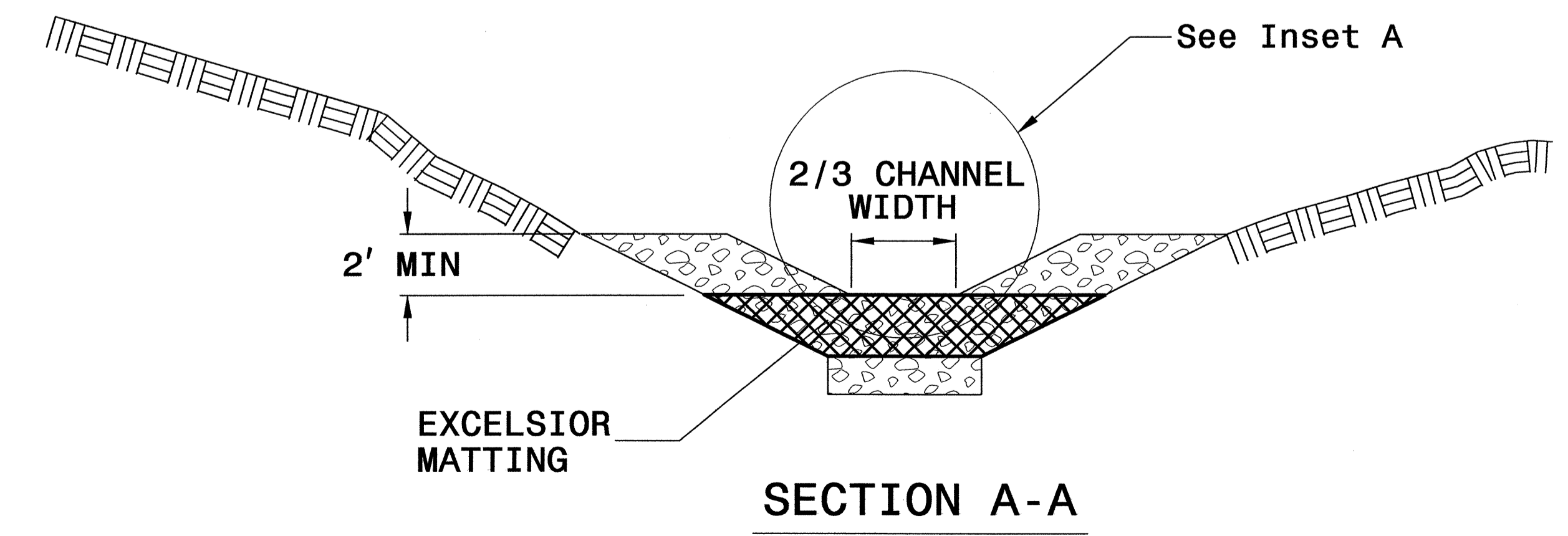
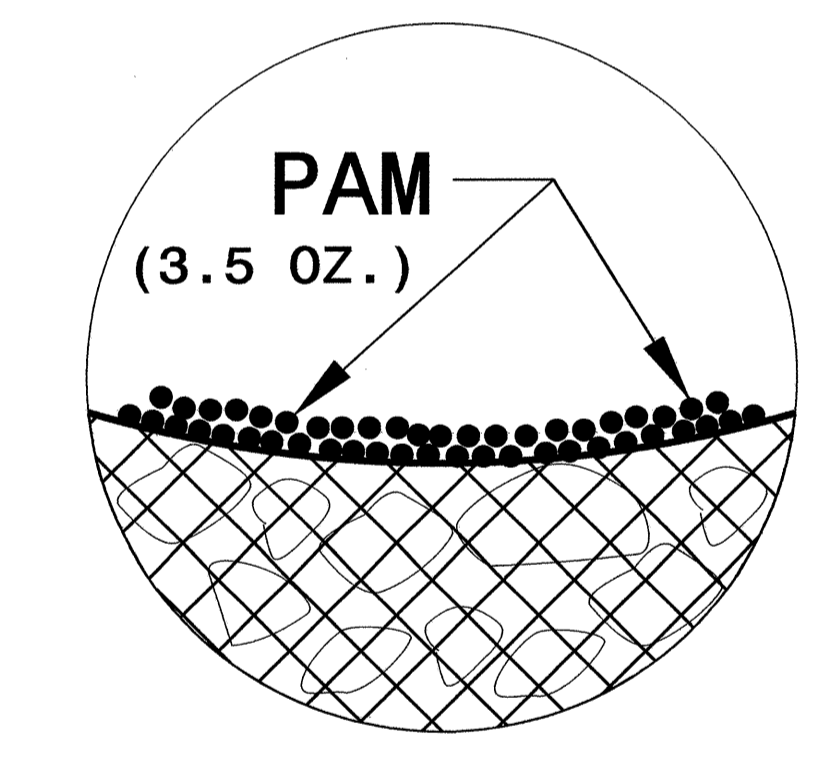

NOT TO SCALE

PROJECT REFERENCE NO. B-4416	SHEET NO. EC-2E
RW SHEET NO.	
ROADWAY DESIGN ENGINEER	HYDRAULICS ENGINEER

MATTING INSTALLATION DETAIL

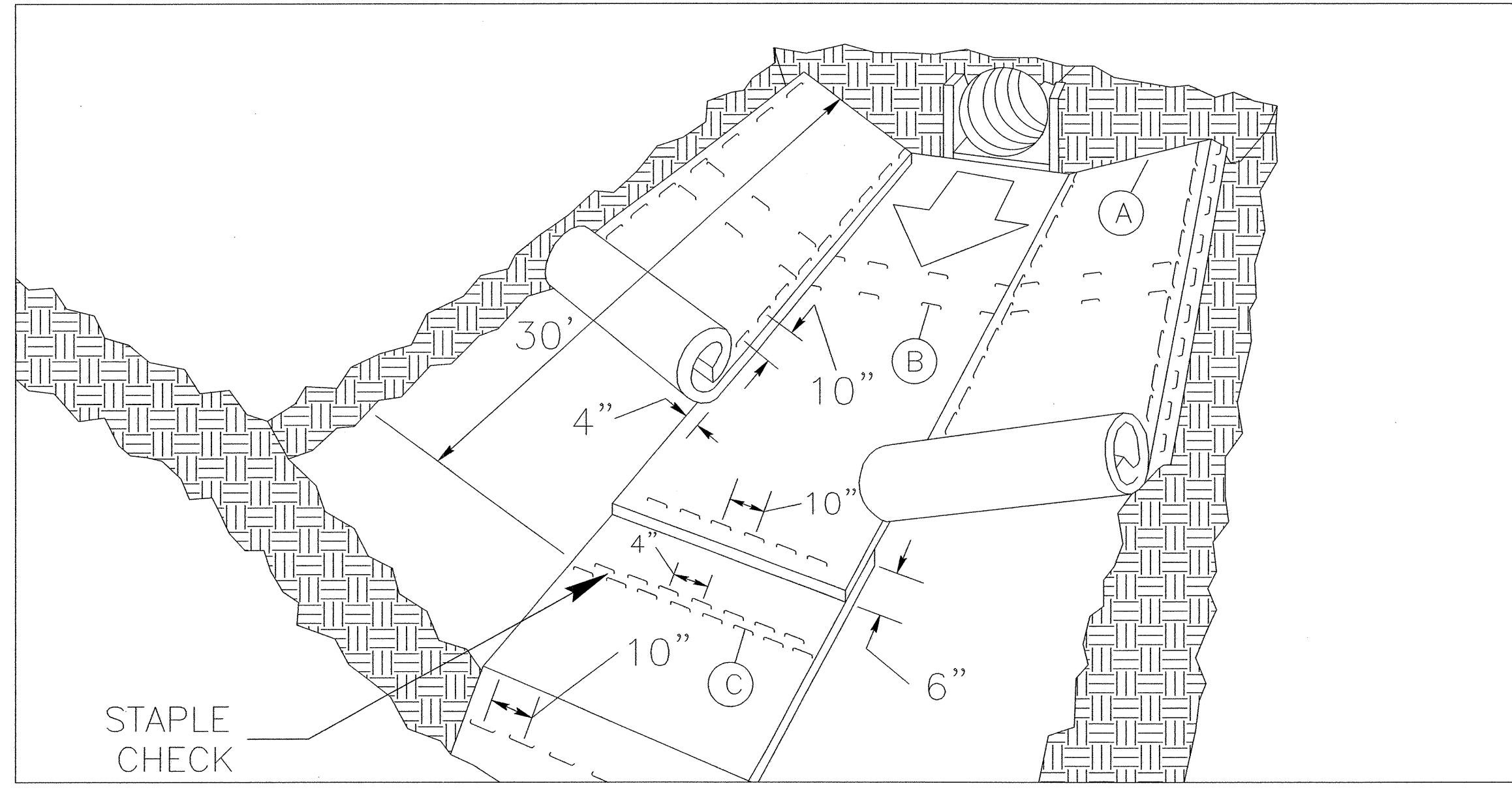

MATTING IN DITCHES

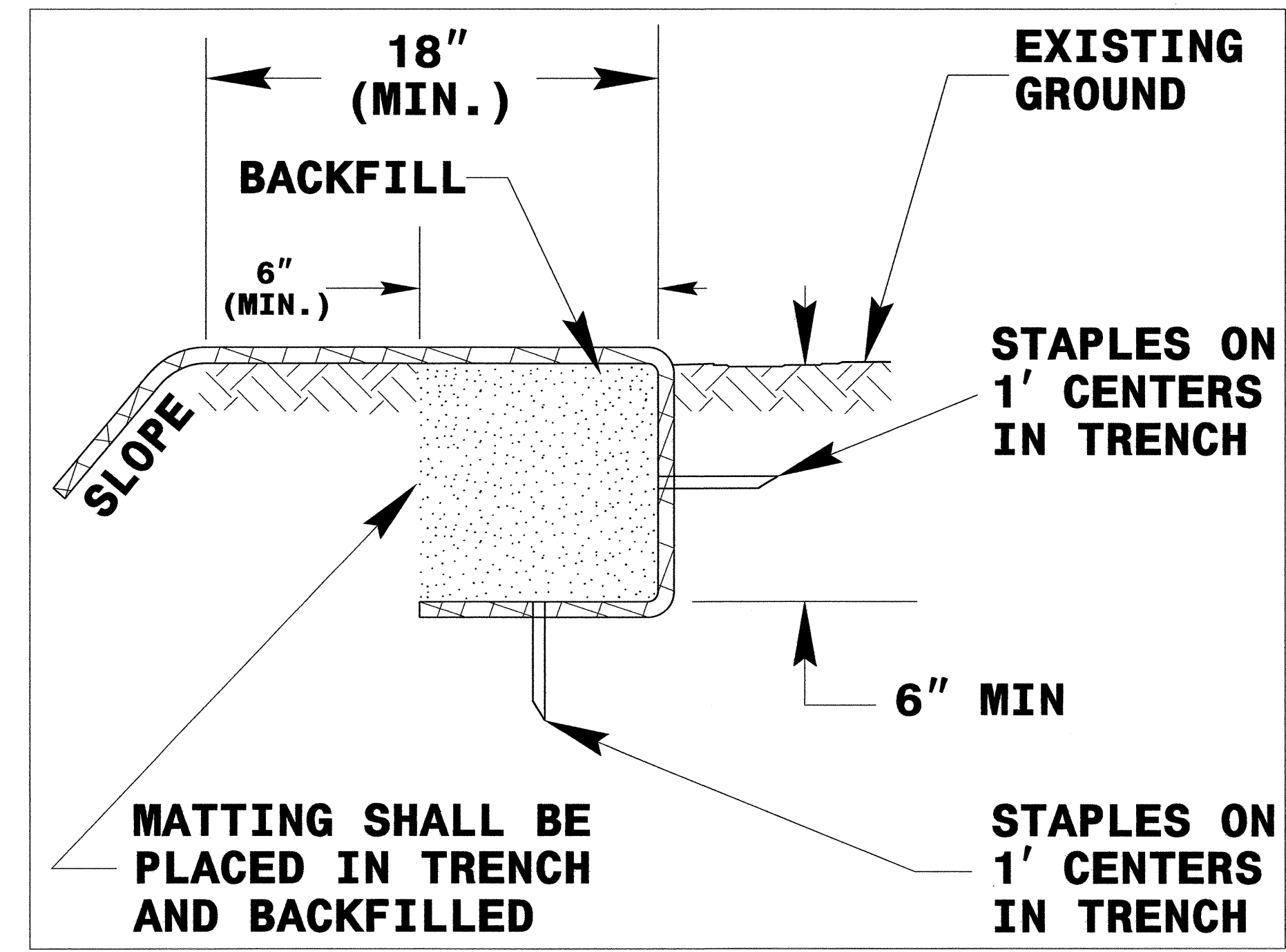
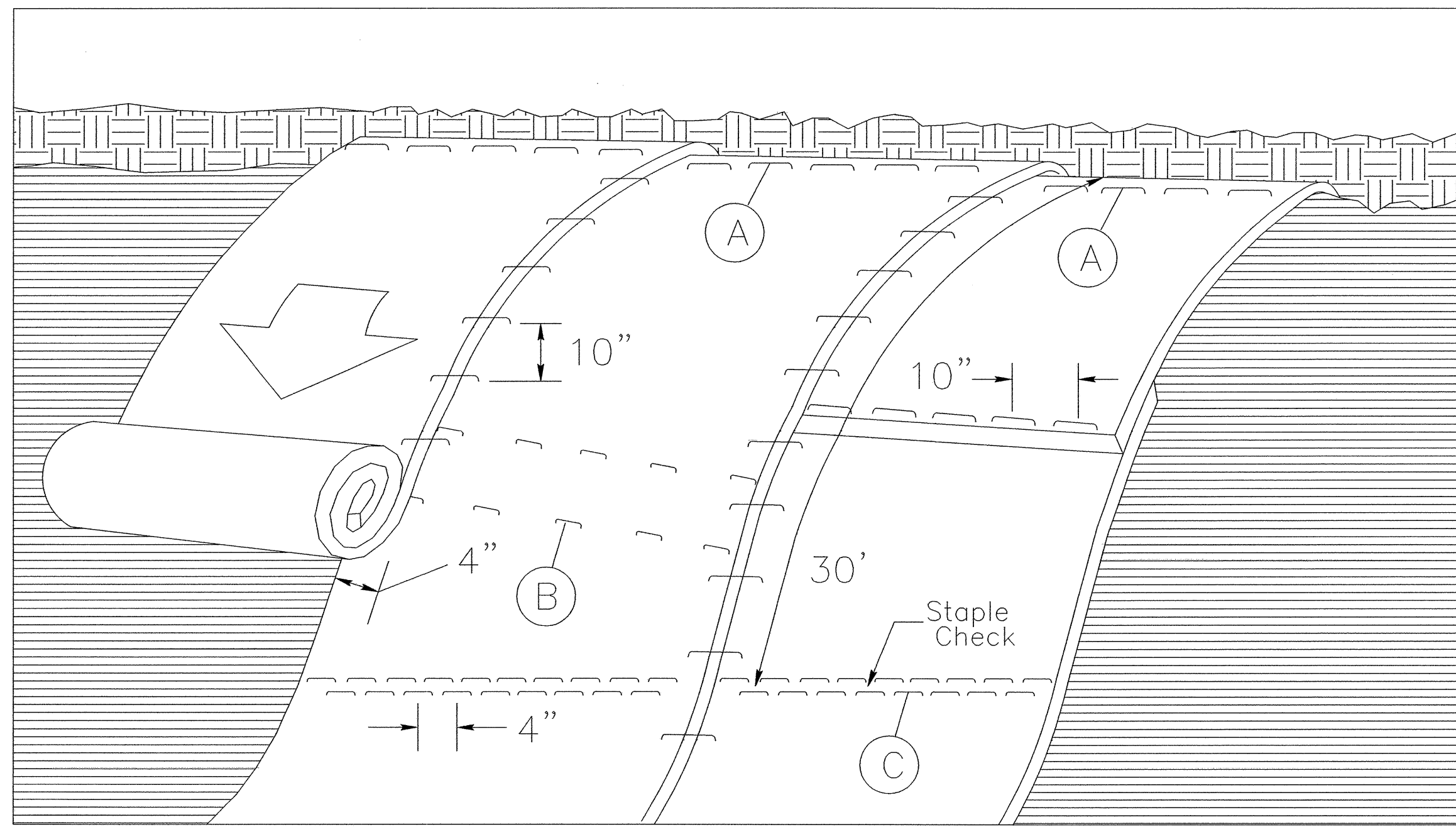

DIAGRAM (A)



MATTING ON SLOPES

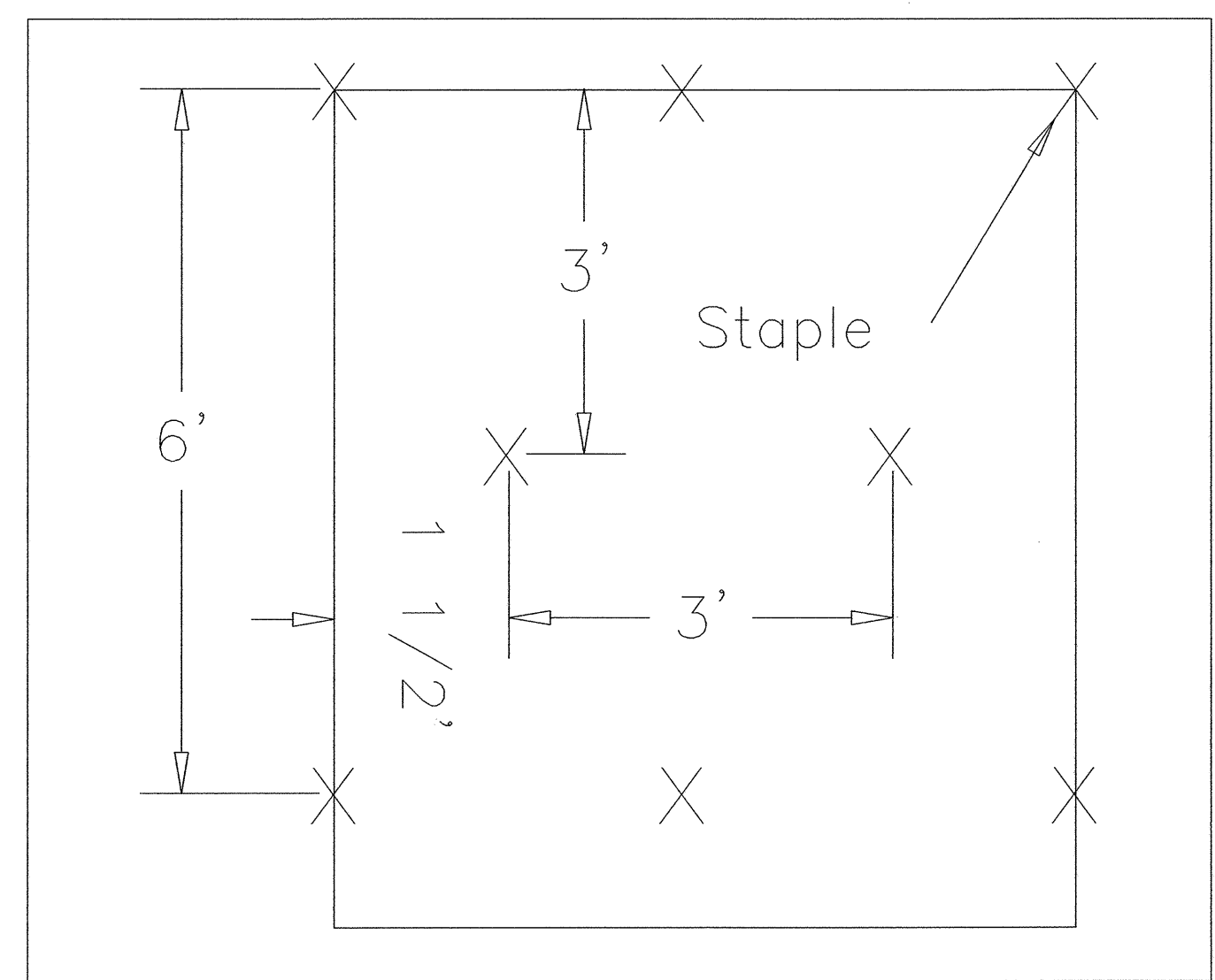

DIAGRAM (B)

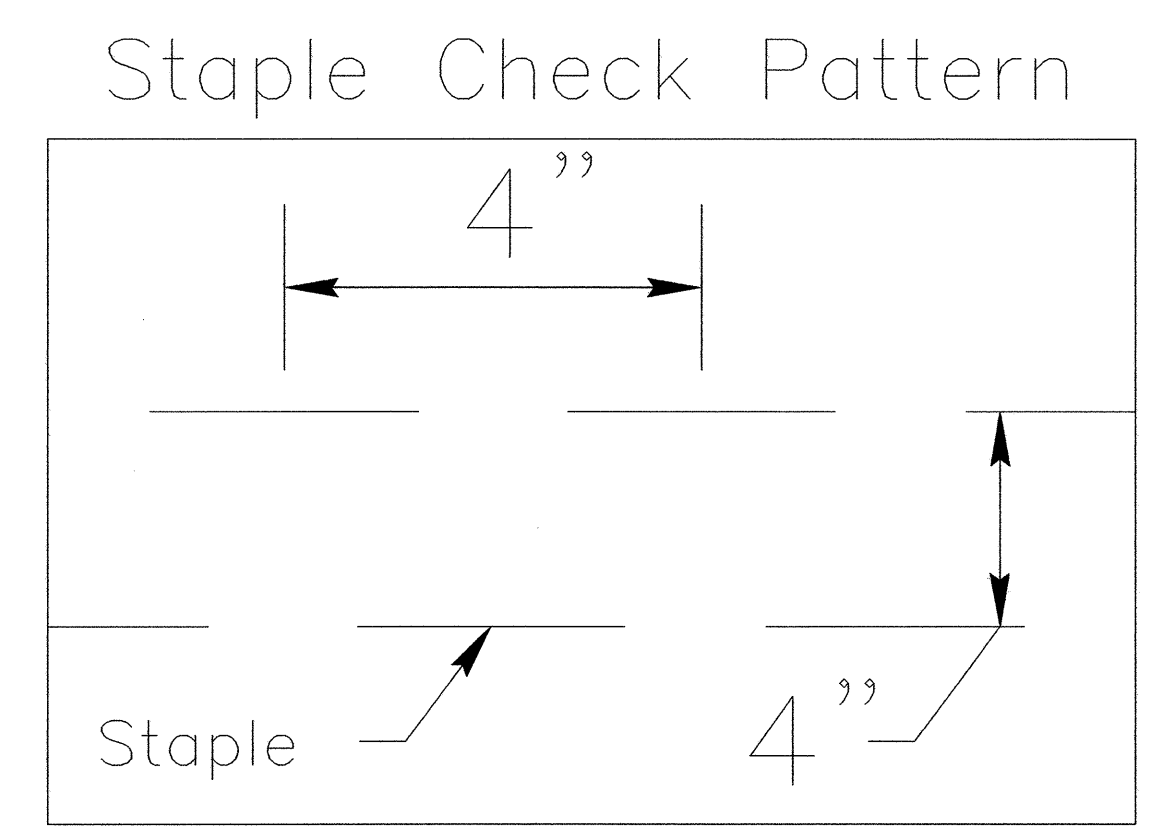

DIAGRAM (C)

NOTES:

THIS DETAIL APPLIES TO STRAW, EXCELSIOR, AND PERMANENT SOIL REINFORCEMENT MAT (PSRM) INSTALLATION.

STAPLES SHALL BE NO. 11 GAUGE STEEL WIRE FORMED INTO A "U" SHAPE WITH A MINIMUM THROAT WIDTH OF 1 INCH AND NOT LESS THAN 6 INCHES IN LENGTH.

NOT TO SCALE

8/17/99

PROJECT REFERENCE NO. B-4416	SHEET NO. EC-4/CONST.4
RW SHEET NO.	
ROADWAY DESIGN ENGINEER	HYDRAULICS ENGINEER

CLEARING AND GRUBBING
EROSION CONTROL FOR
CONSTRUCTION SHEET 4

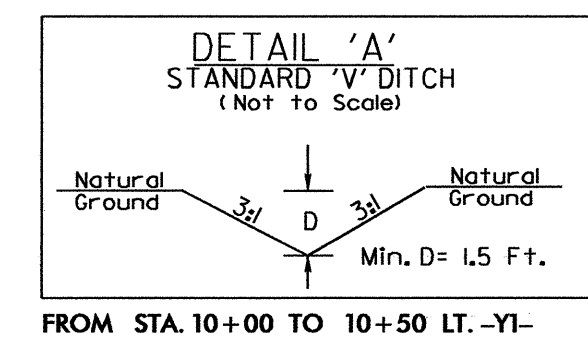
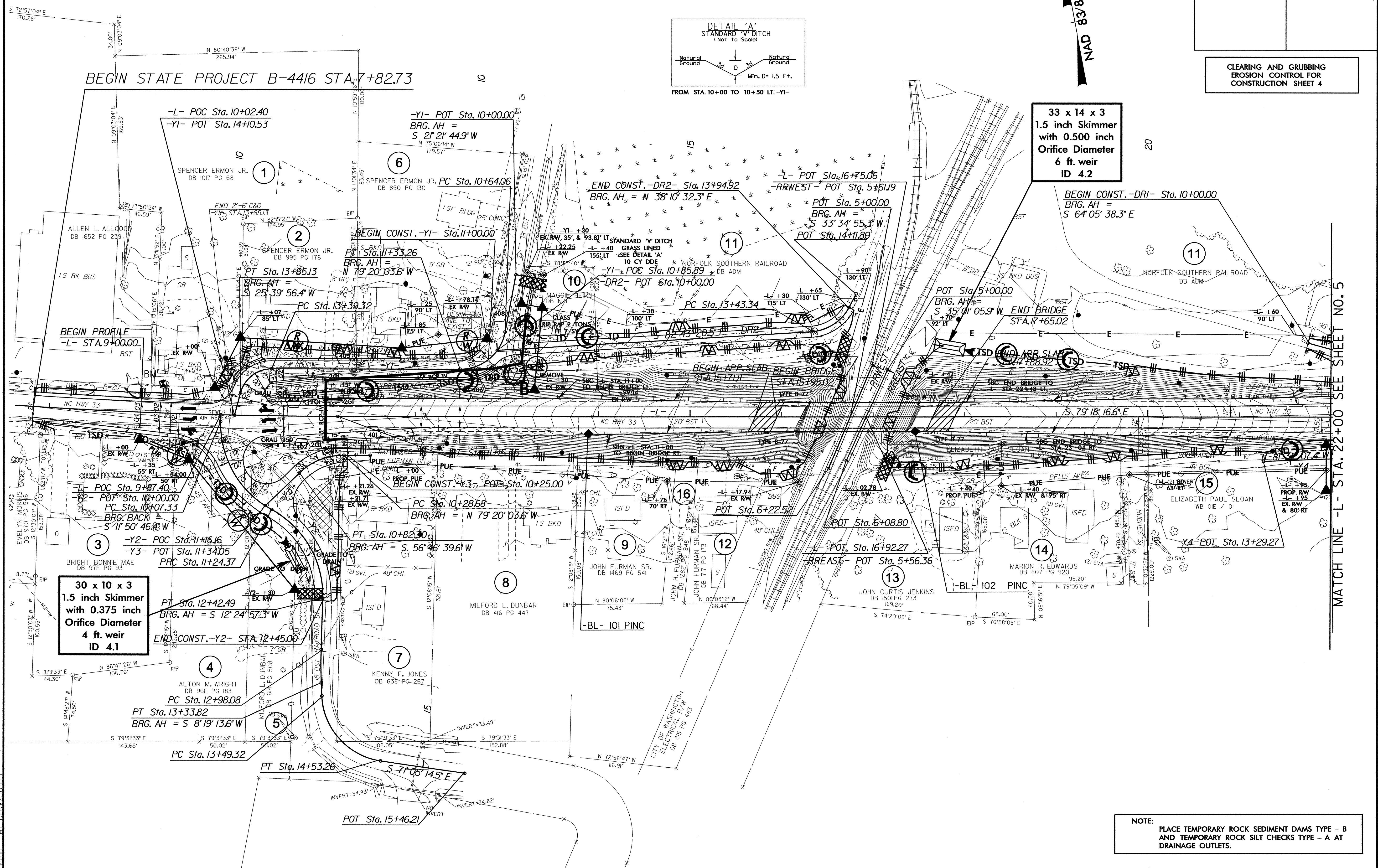

NAD 83/86

MATCH LINE - L - STA. 22+00 SEE SHEET NO. 5

NOTE:
PLACE TEMPORARY ROCK SEDIMENT DAMS TYPE - B
AND TEMPORARY ROCK SILT CHECKS TYPE - A AT
DRAINAGE OUTLETS.

25-JUL-2011 13:48
R:\env\p\at\brn\256388
Design\4416.EC_psh_04.dgn

PROJECT REFERENCE NO. B-4416		SHEET NO. EC-5/CONST.5	
RW SHEET NO.			
ROADWAY DESIGN ENGINEER		HYDRAULICS ENGINEER	

CLEARING AND GRUBBING
EROSION CONTROL FOR
CONSTRUCTION SHEET 5

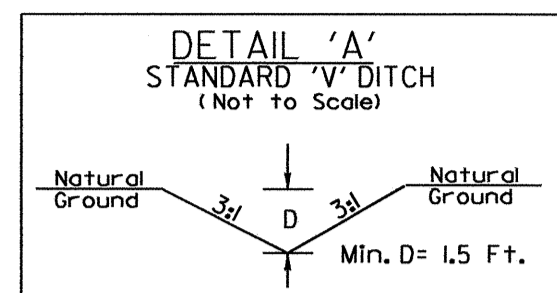

FROM STA. 10+75 TO STA. 12+30 RT. -DRI-
STA. 11+20 LT. -Y4-

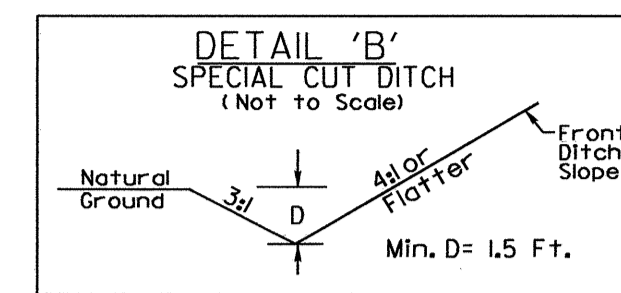

FROM STA. 11+00 TO STA. 11+30 LT. -Y4-
FROM STA. 11+30 TO STA. 11+50 LT. -Y4-

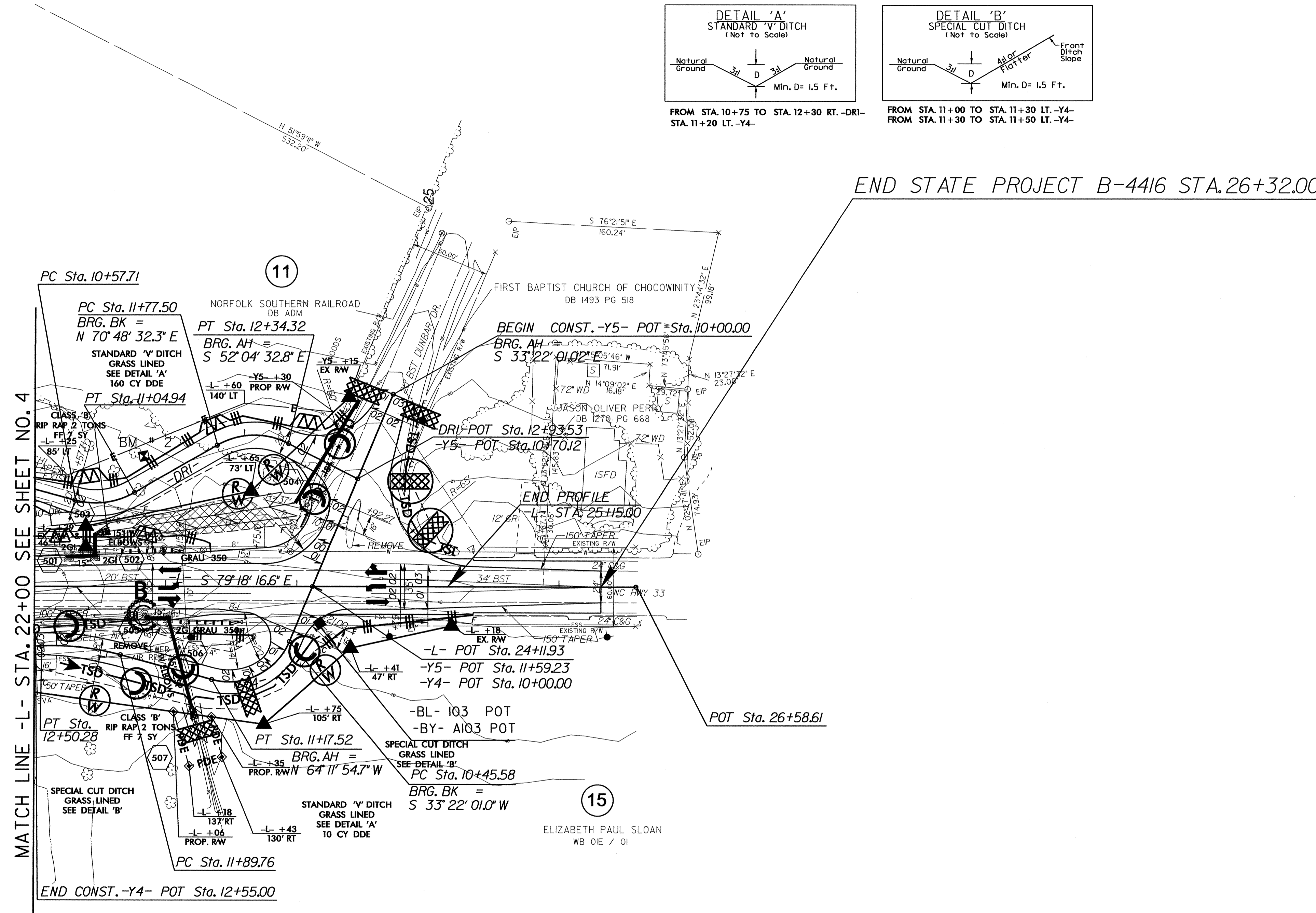
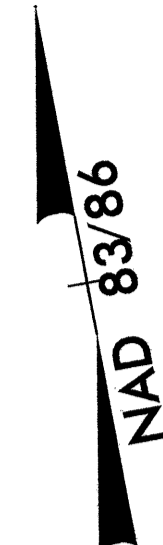

MATCH LINE -L- STA. 22+00 SEE SHEET NO. 4

-DRI-

PI Sta 10+82.63	PI Sta 12+08.53
Δ = 45° 05' 49.4" (LT)	Δ = 57° 06' 54.9" (RT)
D = 95' 29' 34.7"	D = 100' 31' 08.1"
L = 47.23'	L = 56.82'
T = 24.91'	T = 31.02'
R = 60.00'	R = 57.00'
SE = SEE PLANS	SE = SEE PLANS
RO = SEE PLANS	RO = SEE PLANS

-Y4-

PI Sta 10+89.38	PI Sta 12+20.25
Δ = 82° 26' 04.2" (RT)	Δ = 17° 20' 12.7" (LT)
D = 114' 35' 29.6"	D = 28' 38' 52.4"
L = 71.94'	L = 60.52'
T = 43.80'	T = 30.49'
R = 50.00'	R = 200.00'
SE = SEE PLANS	SE = SEE PLANS
RO = SEE PLANS	RO = SEE PLANS

NOTE:
PLACE TEMPORARY ROCK SEDIMENT DAMS TYPE - B
AND TEMPORARY ROCK SILT CHECKS TYPE - A AT
DRAINAGE OUTLETS.

PROJECT REFERENCE NO.	SHEET NO.
B-4416	EC-6/CONST.4
RW SHEET NO.	
ROADWAY DESIGN ENGINEER	HYDRAULICS ENGINEER

8/17/99

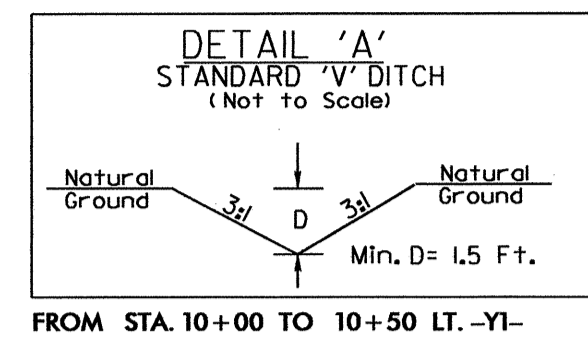
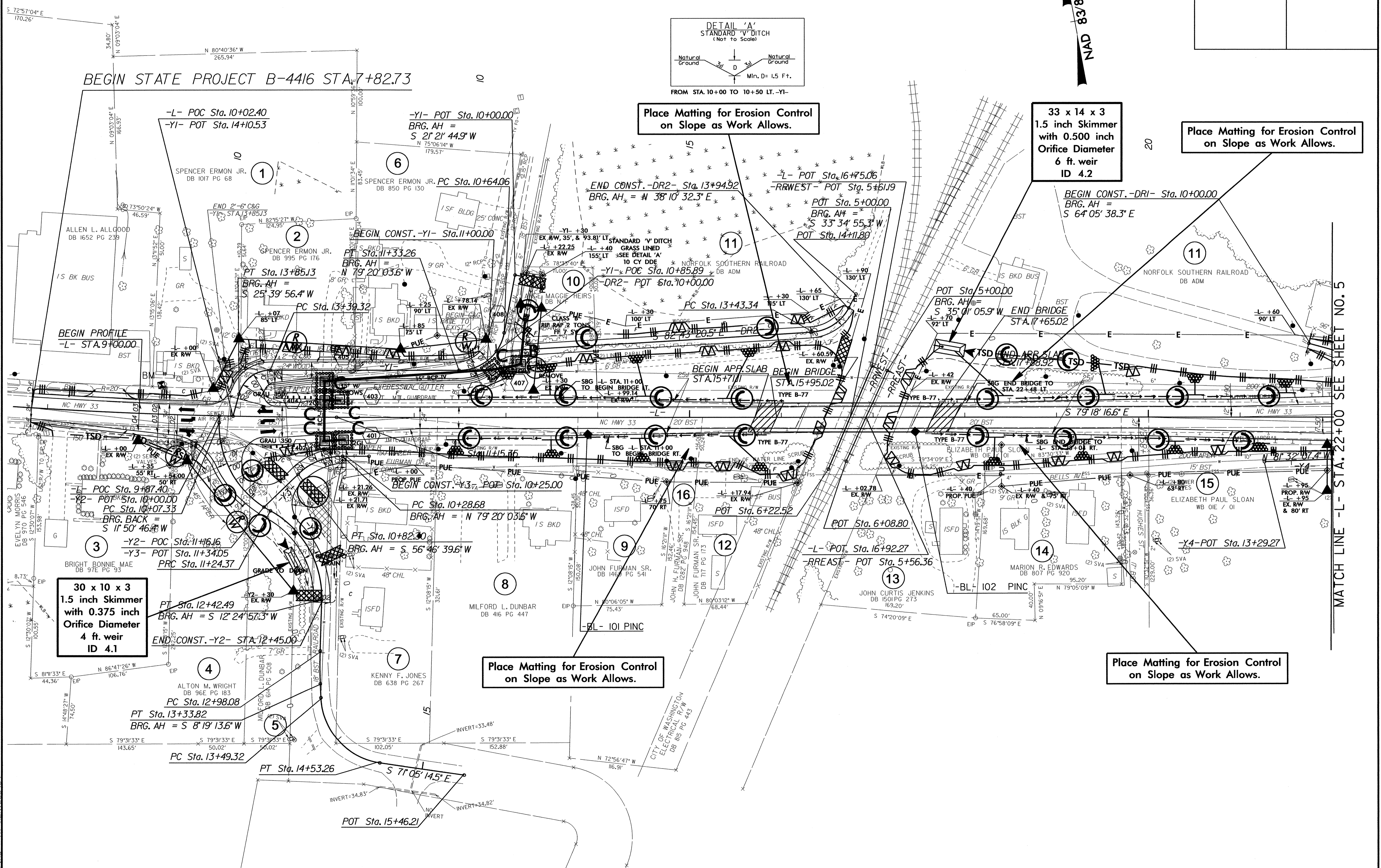

Place Matting for Erosion Control on Slope as Work Allows.

33 x 14 x 3
1.5 inch Skimmer
with 0.500 inch
Orifice Diameter
6 ft. weir
ID 4.2

Place Matting for Erosion Control on Slope as Work Allows.

30 x 10 x 3
1.5 inch Skimmer
with 0.375 inch
Orifice Diameter
4 ft. weir
ID 4.1

Place Matting for Erosion Control on Slope as Work Allows.

Place Matting for Erosion Control on Slope as Work Allows.

MATCH LINE -L- STA. 22+00 SEE SHEET NO. 5

25-JUL-2011 15:50
R:\Environmental\Design\B4416-EC.psh_04.dgn
AT:RENV256395

PROJECT REFERENCE NO.	SHEET NO.
B-4416	EC-7/CONST.5
RW SHEET NO.	
ROADWAY DESIGN ENGINEER	HYDRAULICS ENGINEER

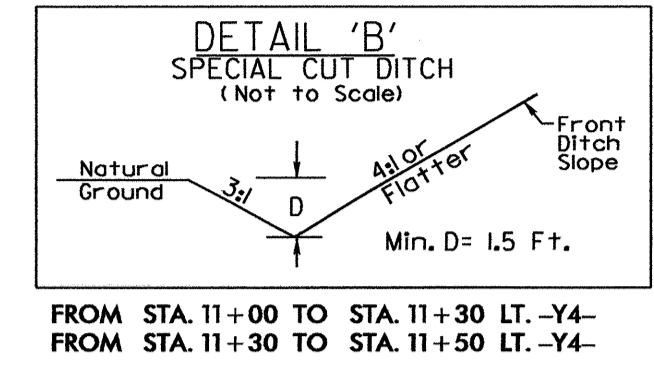
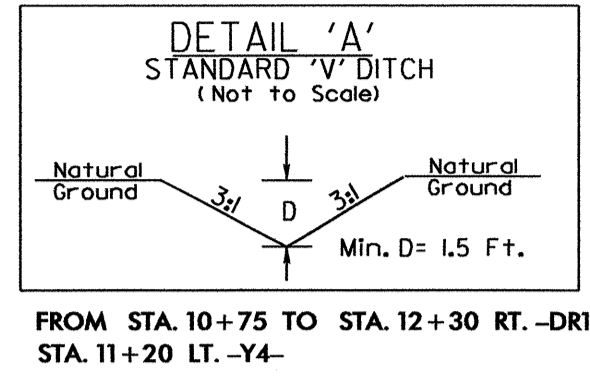
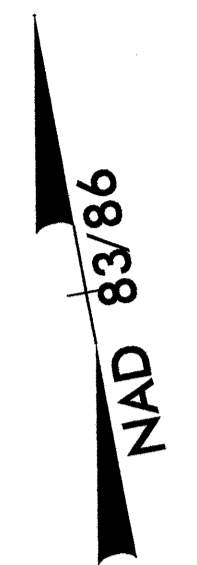

33 x 14 x 3
1.5 inch Skimmer
with 0.500 inch
Orifice Diameter
6 ft. weir
ID 4.3F

END STATE PROJECT B-4416 STA. 26+32.00

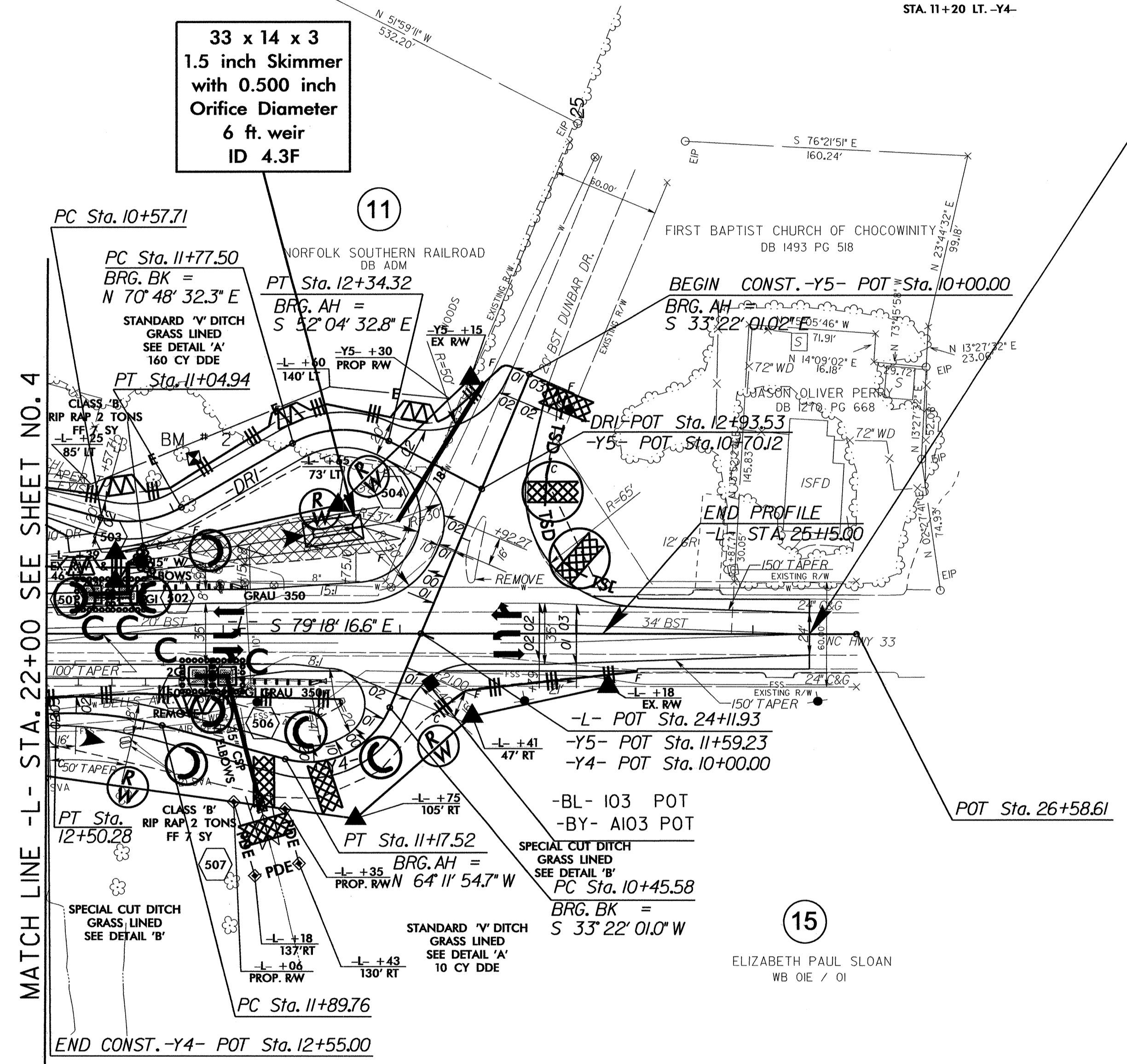

MATCH LINE -L- STA. 22+00 SEE SHEET NO. 4

-DRI-		-Y4-	
PI Sta 10+82.63	PI Sta 12+08.53	PI Sta 10+89.38	PI Sta 12+20.25
Δ = 45° 05' 49.4" (LT)	Δ = 57° 06' 54.9" (RT)	Δ = 82° 26' 04.2" (RT)	Δ = 17° 20' 12.7" (LT)
D = 95' 29' 34.7"	D = 100' 31' 08.1"	D = 114' 35' 29.6"	D = 28' 38' 52.4"
L = 47.23'	L = 56.82'	L = 71.94'	L = 60.52'
T = 24.91'	L = 31.02'	T = 43.80'	T = 30.49'
R = 60.00'	R = 57.00'	R = 50.00'	R = 200.00'
SE = SEE PLANS	SE = SEE PLANS	SE = SEE PLANS	SE = SEE PLANS
RO = SEE PLANS	RO = SEE PLANS	RO = SEE PLANS	RO = SEE PLANS

8/17/99
 25-JUL-2011 13:56
 R:\Environment\Design\B4416_EC_psh_05.dgn
 AT BENV256695