

T.I.P.: R-5185

**STATE OF NORTH CAROLINA
DEPARTMENT OF TRANSPORTATION**

**PAVEMENT MARKING PLANS
HARNETT COUNTY**

**LOCATION: US 401 FROM NC 210 NORTH OF SR 1436
(MATTHEWS ROAD) IN LILLINGTON**

TIP NO. R-5185	SHEET NO. PMP-1
APPROVED:	
DATE: 12-21-10	
SEAL	

ROADWAY STANDARD DRAWING

THE FOLLOWING ROADWAY STANDARDS AS APPEAR IN "ROADWAY STANDARD DRAWINGS" - PROJECT SERVICES UNIT - N.C. DEPARTMENT OF TRANSPORTATION - RALEIGH, N.C., DATED JULY 2006 ARE APPLICABLE TO THIS PROJECT AND BY REFERENCE HEREBY ARE CONSIDERED A PART OF THESE PLANS:

STD. NO.	TITLE
1205.01	PAVEMENT MARKINGS - LINE TYPES AND OFFSETS
1205.02	PAVEMENT MARKINGS - 2 LANE AND MULTILANE ROADWAYS
1205.04	PAVEMENT MARKINGS - INTERSECTIONS
1205.05	PAVEMENT MARKINGS - TURN LANES
1205.07	PAVEMENT MARKINGS - PEDESTRIAN CROSSINGS
1205.08	PAVEMENT MARKINGS - SYMBOL AND WORD MESSAGES
1205.09	PAVEMENT MARKINGS - PAINTED ISLANDS
1250.01	PAVEMENT MARKER SPACING
1261.01	GUARDRAIL AND BARRIER DELINEATOR SPACING
1261.02	GUARDRAIL AND BARRIER DELINEATOR TYPES
1262.01	GUARDRAIL END DELINEATION

GENERAL NOTES

THE FOLLOWING GENERAL NOTES APPLY AT ALL TIMES FOR THE DURATION OF THE CONSTRUCTION PROJECT, EXCEPT WHEN OTHERWISE NOTED IN THE PLAN, OR DIRECTED BY THE ENGINEER.

- A) INSTALL PAVEMENT MARKINGS AND PAVEMENT MARKERS ON THE FINAL SURFACES AS FOLLOWS:

ROAD NAME	MARKING	MARKER
US 401 (-L-)	THERMOPLASTIC	RAISED
- B) TIE PROPOSED PAVEMENT MARKING LINES TO EXISTING PAVEMENT MARKING LINES.
- C) REMOVE/REPLACE ANY CONFLICTING/DAMAGED PAVEMENT MARKINGS AND MARKERS.
- D) STOPBAR LOCATION AT NON-SIGNALIZED INTERSECTIONS MAY BE ADJUSTED AS DIRECTED BY THE ENGINEER.

INDEX

SHEET NO.	DESCRIPTION
PMP-1	PAVEMENT MARKING PLAN TITLE SHEET
PMP-2	PAVEMENT MARKING SCHEDULE
PMP-3-6	PAVEMENT MARKING DETAILS

PLAN PREPARED BY: N.C.D.O.T. SIGNING AND DELINEATION UNIT

AYMAN ALQUDWAH, P.E. SIGNING & DELINEATION REGIONAL ENGINEER
D. PILLAR SIGNING & DELINEATION DESIGN ENGINEER

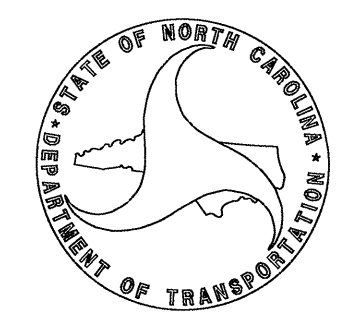

TIP NO.	SHEET NO.
R-5185	PMP-2
APPROVED: <i>[Signature]</i>	
DATE: 3-24-11	
SEAL	
	

PAVEMENT MARKING SCHEDULE

SYMBOL AND PAVEMENT MARKING LEGEND

- THERMOPLASTIC
- ↶ UA LEFT TURN ARROW
 - ↷ UB RIGHT TURN ARROW
 - ← UC STRAIGHT ARROW
 - ↷ UE COMBO STRAIGHT/RIGHT ARROW
 - ONLY UI ALPHANUMERIC CHARACTER

- THERMOPLASTIC
- (TA) WHITE EDGELINE
 - (TB) YELLOW EDGELINE
 - (T11) 2 FT. - 8 FT./SP YELLOW MINISKIP
 - (T8) 2 FT. - 8 FT./SP WHITE MINISKIP
 - (TC) 10 FT. WHITE SKIP
 - (TD) 2 FT. - 13 FT./SP WHITE MINISKIP
 - (TE) WHITE SOLID LANE LINE
 - (TI) YELLOW DOUBLE CENTER
 - (TP) WHITE GORELINE
 - (TQ) WHITE DIAGONAL
 - (TT) YELLOW DIAGONAL
 - (TV) WHITE CROSSWALK
 - (T1) WHITE LINE RR X
 - (T2) WHITE STOPBAR
 - (UI) ALPHA NUMERIC CHARACTER
 - (UA) LEFT ARROW
 - (UB) RIGHT ARROW
 - (UC) STRAIGHT ARROW
 - (UE) COMBO STRAIGHT/RIGHT ARROW
 - (TH) YELLOW SINGLE CENTER
 - (TF) 10 FT. YELLOW SKIP

SYMBOL	DESCRIPTION	QUANTITY BREAKDOWN	TOTAL QUANTITY
THERMOPLASTIC(4", 90 MILS)			
TA	WHITE EDGELINE		3025LF
TB	YELLOW EDGELINE		10611LF
		TOTAL (4", 90 MILS)	13636 LF
THERMOPLASTIC(4", 120 MILS)			
T11	2 FT. - 8 FT./SP YELLOW MINISKIP		23LF
T8	2 FT. - 8 FT./SP WHITE MINISKIP		46LF
TC	10 FT. WHITE SKIP		3460LF
TD	2 FT. - 13 FT./SP WHITE MINISKIP		513LF
TE	WHITE SOLID LANE LINE		3464LF
TF	10 FT. YELLOW SKIP		121LF
TH	YELLOW SINGLE CENTER		484LF
TI	YELLOW DOUBLE CENTER		5250LF
		TOTAL (4", 120 MILS)	13361 LF
THERMOPLASTIC(8", 90 MILS)			
TP	WHITE GORELINE		3579LF
TQ	WHITE DIAGONAL		295LF
TT	YELLOW DIAGONAL		256LF
		TOTAL (8", 90 MILS)	4130 LF
THERMOPLASTIC(8", 120 MILS)			
TV	WHITE CROSSWALK LINE		2773LF
THERMOPLASTIC(16", 120 MILS)			
T1	WHITE LINE, RR CROSSB		47LF
THERMOPLASTIC(24", 120 MILS)			
T2	WHITE STOPBAR		945LF
THERMOPLASTIC PAVEMENT MARKING CHARACTER (120 MILS)			
UI	ALPHANUMERIC CHAR.		22EA
THERMOPLASTIC PAVEMENT MARKING SYMBOLS (90 MILS)			
UA	LEFT TURN ARROW		44EA
UB	RIGHT TURN ARROW		34EA
UC	STRAIGHT ARROW		37EA
UE	COMBO STRAIGHT/RIGHT		7EA
		TOTAL PAVEMENT MARKING SYMBOLS (90 MILS)	122 EA
PERMANENT RAISED PAVEMENT MARKERS			
MB	CRYSTAL & RED		538EA
MA	YELLOW & YELLOW		60EA
		TOTAL PERMANENT RAISED PAVEMENT MARKERS	598 EA

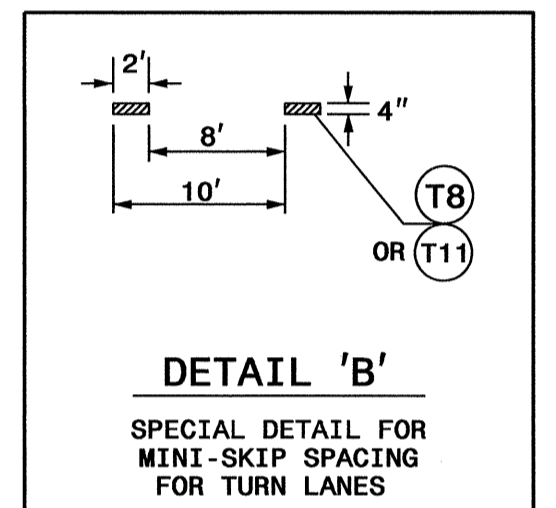

APPROVED: *John ...*
 DATE: 3-24-11



SYMBOL AND PAVEMENT MARKING LEGEND

THERMOPLASTIC

↩ UA LEFT TURN ARROW
 ↪ UB RIGHT TURN ARROW
 ↑ UC STRAIGHT ARROW
 ↗ UE COMBO STRAIGHT/RIGHT ARROW
 ONLY UI ALPHANUMERIC SYMBOL

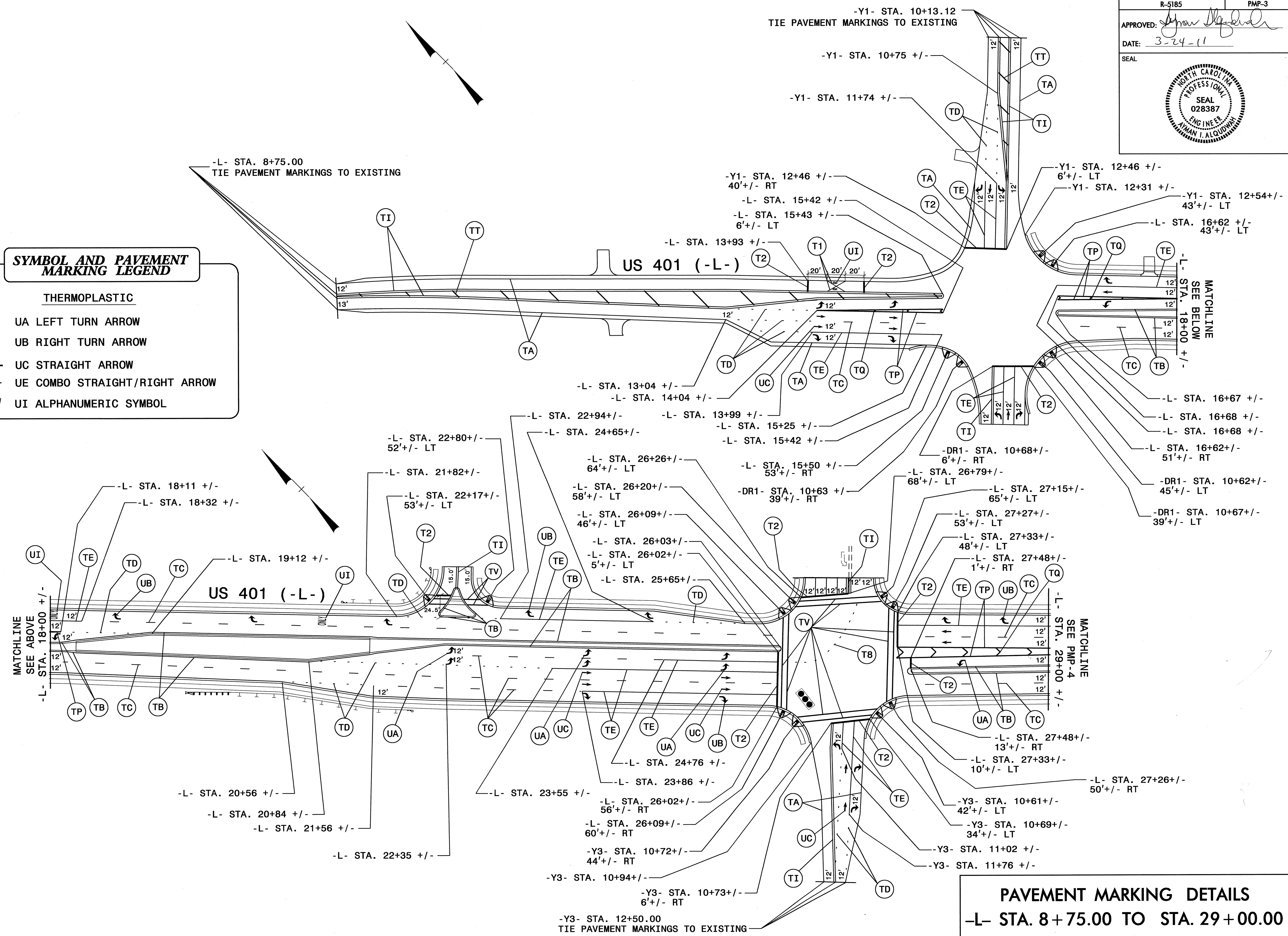



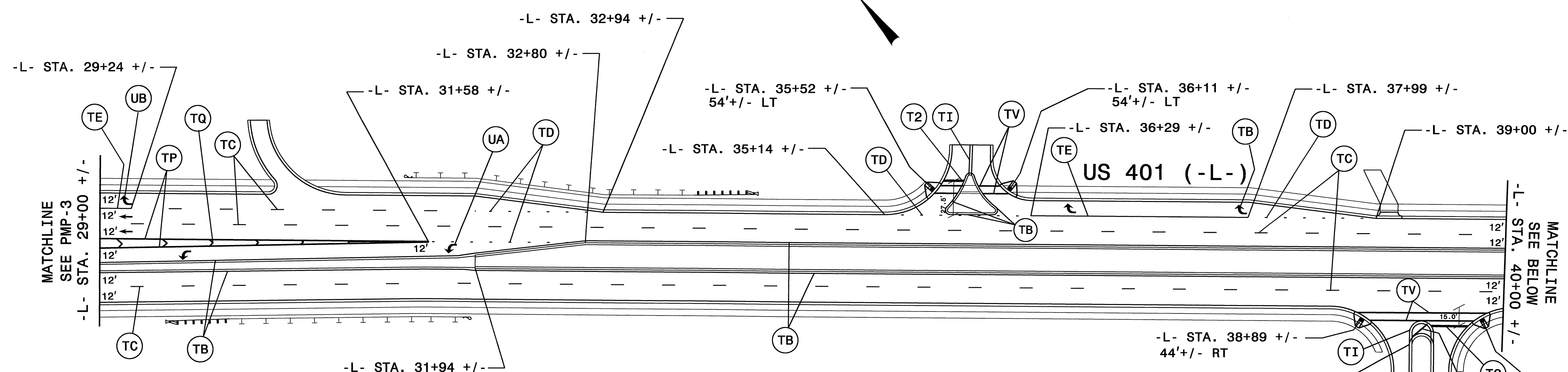

PAVEMENT MARKING DETAILS
 -L- STA. 8+75.00 TO STA. 29+00.00



SYMBOL AND PAVEMENT MARKING LEGEND

THERMOPLASTIC

-  UA LEFT TURN ARROW
-  UB RIGHT TURN ARROW
-  UC STRAIGHT ARROW
-  UE COMBO STRAIGHT/RIGHT ARROW
- ONLY UI ALPHANUMERIC SYMBOL

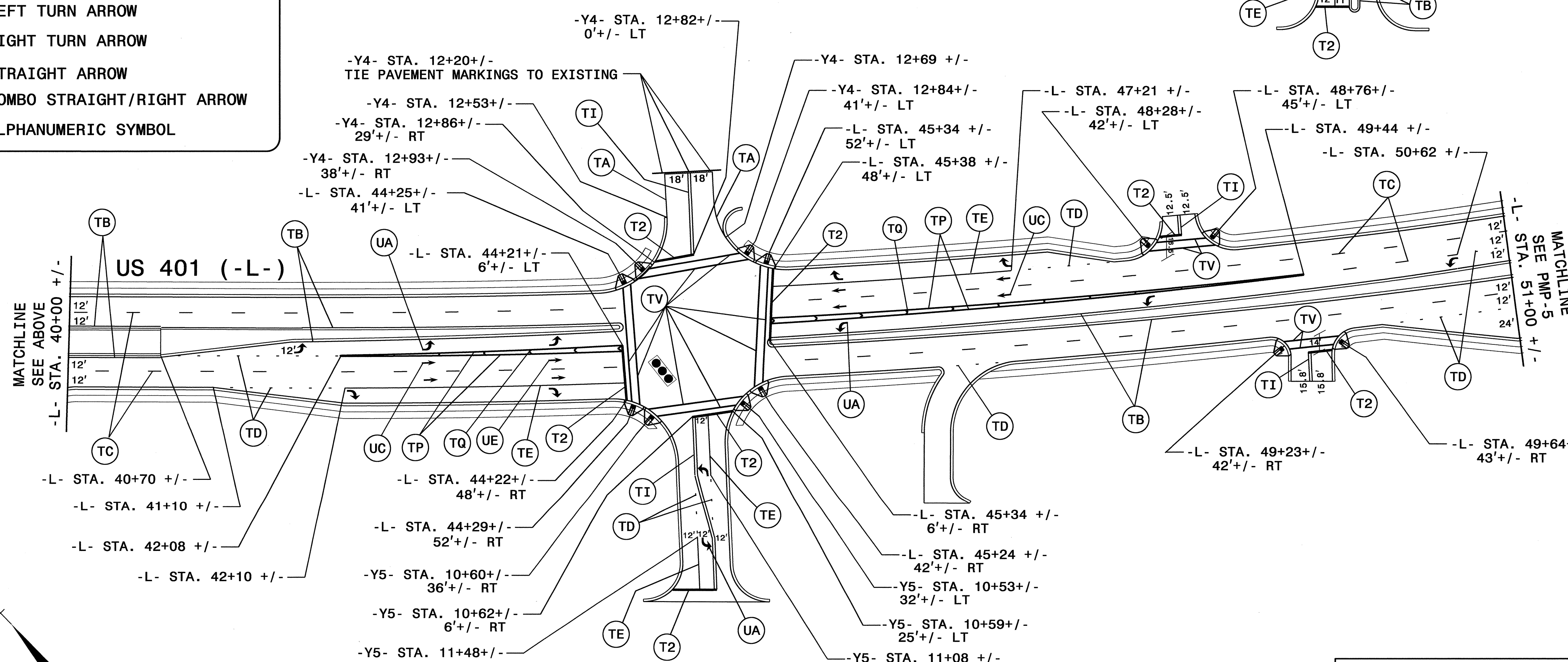

PAVEMENT MARKING DETAILS
-L- STA. 29+00.00 TO STA. 51+00.00



SYMBOL AND PAVEMENT MARKING LEGEND

THERMOPLASTIC

- ← UA LEFT TURN ARROW
- UB RIGHT TURN ARROW
- ← UC STRAIGHT ARROW
- ↔ UE COMBO STRAIGHT/RIGHT ARROW
- ONLY UI ALPHANUMERIC SYMBOL

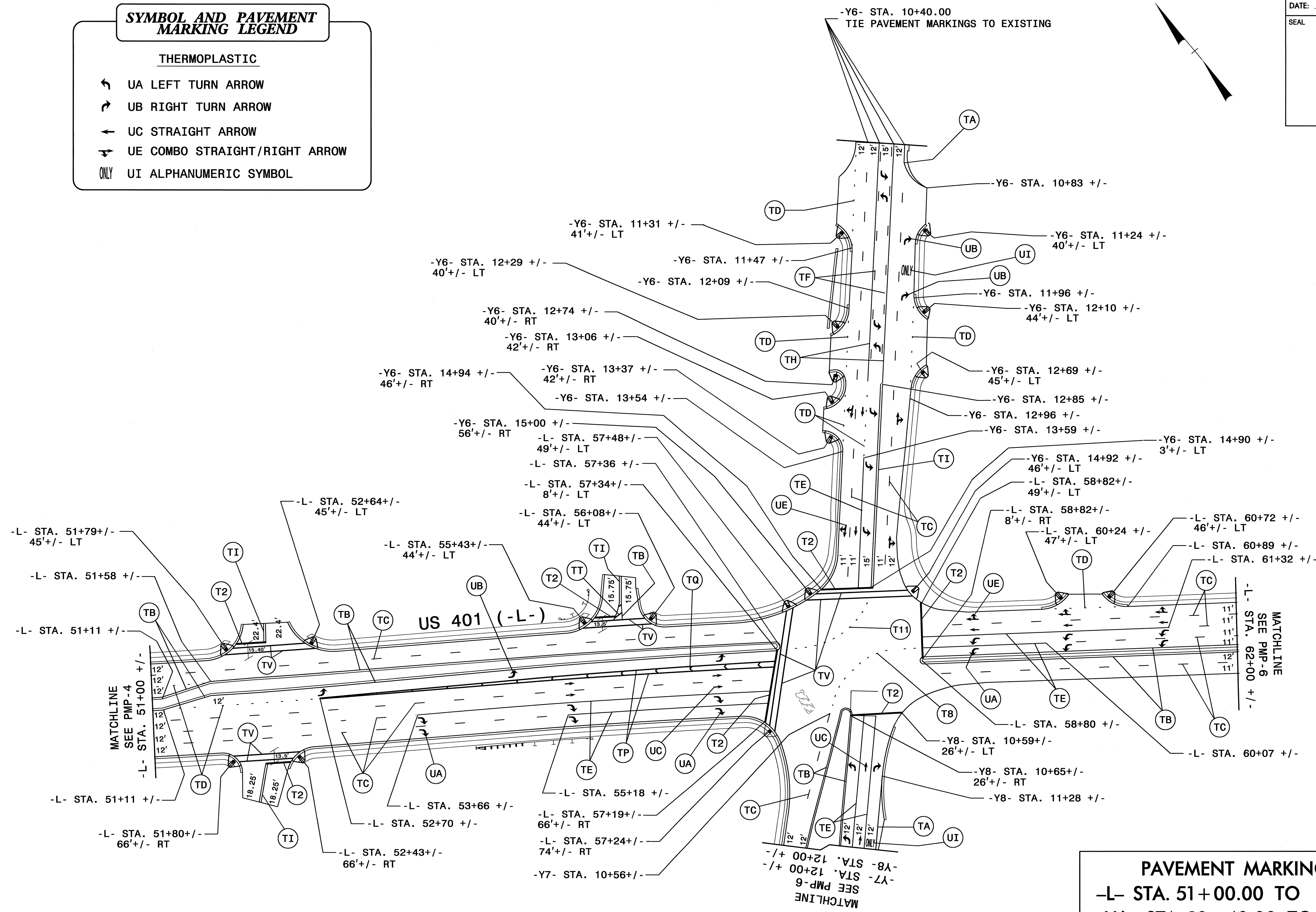

PAVEMENT MARKING DETAILS

- L- STA. 51+00.00 TO STA. 62+00.00
- Y6- STA. 10+40.00 TO STA. 15+56.81
- Y7- STA. 10+00.14 TO STA. 12+00.00
- Y8- STA. 10+00.00 TO STA. 12+00.00

SYMBOL AND PAVEMENT MARKING LEGEND

THERMOPLASTIC

- ↶ UA LEFT TURN ARROW
- ↷ UB RIGHT TURN ARROW
- ← UC STRAIGHT ARROW
- ↷ UE COMBO STRAIGHT/RIGHT ARROW
- ONLY UI ALPHANUMERIC SYMBOL

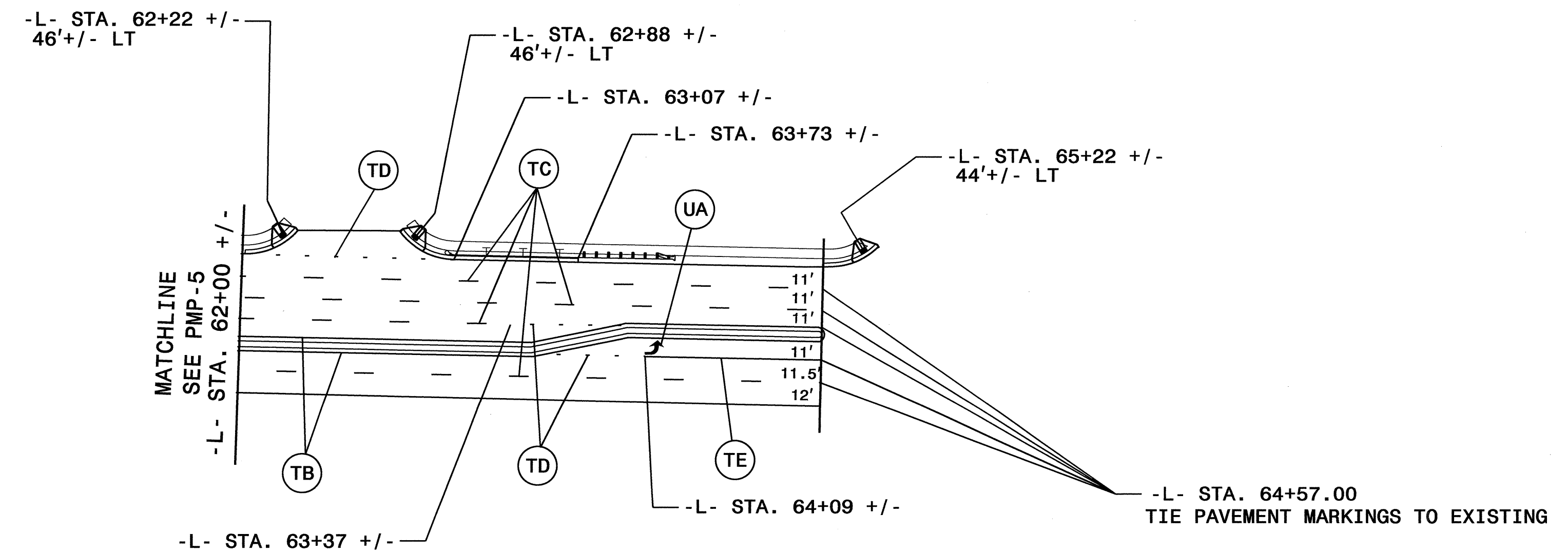
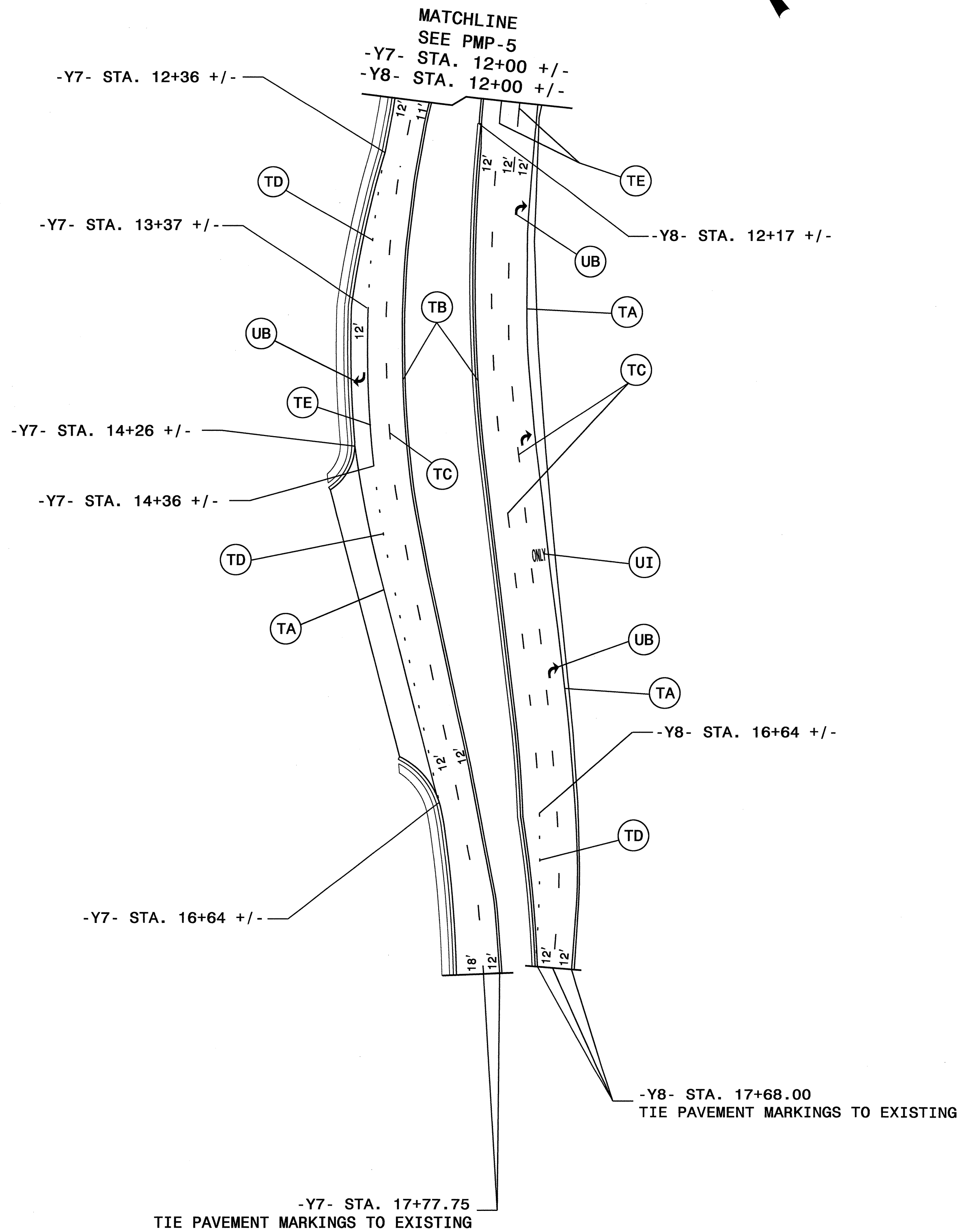

PAVEMENT MARKING DETAILS
 -L- STA. 62+00.00 TO STA. 64+57.00
 -Y7- STA. 12+00.00 TO STA. 17+77.75
 -Y8- STA. 12+00.00 TO STA. 17+68.00