

C:\APR-2011\0837  
 R:\Traffic\Signing\CADD\Quantities & GM\Sigma U-4019\eed.dgn  
 bnowlin AT 11/27/11

**CONTRACT: C202621 T.I.P.: U-4019**

**STATE OF NORTH CAROLINA  
 DEPARTMENT OF TRANSPORTATION**

**PAVEMENT MARKING PLAN**

**NASH COUNTY**

**LOCATION: SR-1613 N. WINSTEAD AVE. FROM SR-1770 SUNSET AVE.  
 TO SR-1604 HUNTER HILL RD.**

TIP NO. U-4019	SHEET NO. PMP-1
APPROVED:	
DATE: 4-5-11	

**ROADWAY STANDARD DRAWING**

THE FOLLOWING ROADWAY STANDARDS AS APPEAR IN "ROADWAY STANDARD DRAWINGS" - PROJECT SERVICES UNIT - N.C. DEPARTMENT OF TRANSPORTATION - RALEIGH, N.C., DATED JULY 2006 ARE APPLICABLE TO THIS PROJECT AND BY REFERENCE HEREBY ARE CONSIDERED A PART OF THESE PLANS:

STD. NO.	TITLE
1205.01	PAVEMENT MARKINGS - LINE TYPES AND OFFSETS
1205.02	PAVEMENT MARKINGS - 2 LANE AND MULTILANE ROADWAYS
1205.03	PAVEMENT MARKINGS - INTERCHANGES
1205.04	PAVEMENT MARKINGS - INTERSECTIONS
1205.05	PAVEMENT MARKINGS - TURN LANES
1205.06	PAVEMENT MARKINGS - THRU LANE DROPS
1205.07	PAVEMENT MARKINGS - PEDESTRIAN CROSSINGS
1205.08	PAVEMENT MARKINGS - SYMBOL AND WORD MESSAGES
1205.09	PAVEMENT MARKINGS - PAINTED ISLANDS
1205.12	PAVEMENT MARKINGS - BRIDGES
1250.01	PAVEMENT MARKER SPACING
1251.01	RAISED PAVEMENT MARKERS - TEMPORARY AND PERMANENT
1253.01	SNOWPLOWABLE RAISED PAVEMENT MARKERS
1261.01	GUARDRAIL AND BARRIER DELINEATOR SPACING
1261.02	GUARDRAIL AND BARRIER DELINEATOR TYPES
1262.01	GUARDRAIL END DELINEATION
1264.01	OBJECT MARKERS
1264.02	PLACEMENT OF OBJECT MARKERS
1267.01	FLEXIBLE DELINEATOR INSTALLATION
1267.02	FLEXIBLE DELINEATOR SPACING
1267.03	FLEXIBLE DELINEATOR - INTERCHANGES

Pavement Marking Schedule  
TIP Project # U-4019

SYMBOL	DESCRIPTION
FINAL PAVEMENT MARKINGS	
THERMOPLASTIC(24", 120 MILS)	
T2	WHITE STOPBAR
T3	WHITE CROSSWALK LINE POLYUREA(4")
V8	2 FT. - 8 FT./SP WHITE MINISKIP
VA	WHITE EDGELINE
VB	YELLOW EDGELINE
VD	2 FT. - 13 FT./SP WHITE MINISKIP THERMOPLASTIC(4", 120 MILS)
T8	2 FT. - 8 FT./SP WHITE MINISKIP
TC	10 FT. WHITE SKIP
TD	2 FT. - 13 FT./SP WHITE MINISKIP
TE	WHITE SOLID LANE LINE
TI	YELLOW DOUBLE CENTER THERMOPLASTIC(4", 90 MILS)
TA	WHITE EDGELINE
TB	YELLOW EDGELINE
THERMOPLASTICPAVEMENT MARKING CHARACTER (120 MILS)	
UI	ALPHANUMERIC CHAR.
THERMOPLASTICPAVEMENT MARKING SYMBOLS (90 MILS)	
UA	LEFT TURN ARROW
UB	RIGHT TURN ARROW
UC	STRAIGHT ARROW
UD	COMBO.STRAIGHT/LEFT
SYMBOL DESCRIPTION	
MARKERS	
PERMANENT RAISED PAVEMENT MARKERS	
MB	CRYSTAL & RED

**GENERAL NOTES**

THE FOLLOWING GENERAL NOTES APPLY AT ALL TIMES FOR THE DURATION OF THE CONSTRUCTION PROJECT, EXCEPT WHEN OTHERWISE NOTED IN THE PLAN, OR DIRECTED BY THE ENGINEER.

- A) INSTALL PAVEMENT MARKINGS AND PAVEMENT MARKERS ON THE FINAL SURFACE AS FOLLOWS:
 

ROAD NAME	MARKING	MARKER
WINSTEAD AVE	THERMO & POLYUREA OR TAPE	RAISED
- B) TIE PROPOSED PAVEMENT MARKING LINES TO EXISTING PAVEMENT MARKING LINES.
- C) REMOVE/REPLACE ANY CONFLICTING/DAMAGED PAVEMENT MARKINGS AND MARKERS.
- D) PASSING ZONE WILL BE DETERMINED IN THE FIELD AND MUST BE APPROVED BY THE ENGINEER.

**PLAN PREPARED BY: N.C.D.O.T. SIGNING AND DELINEATION SECTION**

**AYMAN I. ALQUDWAH P.E. SIGNING & DELINEATION REGIONAL ENGINEER**

**BARRY NOWLIN SIGNING & DELINEATION PROJECT DESIGN TECHNICIAN**

**INDEX**

SHEET NO.	DESCRIPTION
PMP-1	FINAL PAVEMENT MARKING PLAN COVER SHEET
PMP-2-8	FINAL PAVEMENT MARKING DETAIL

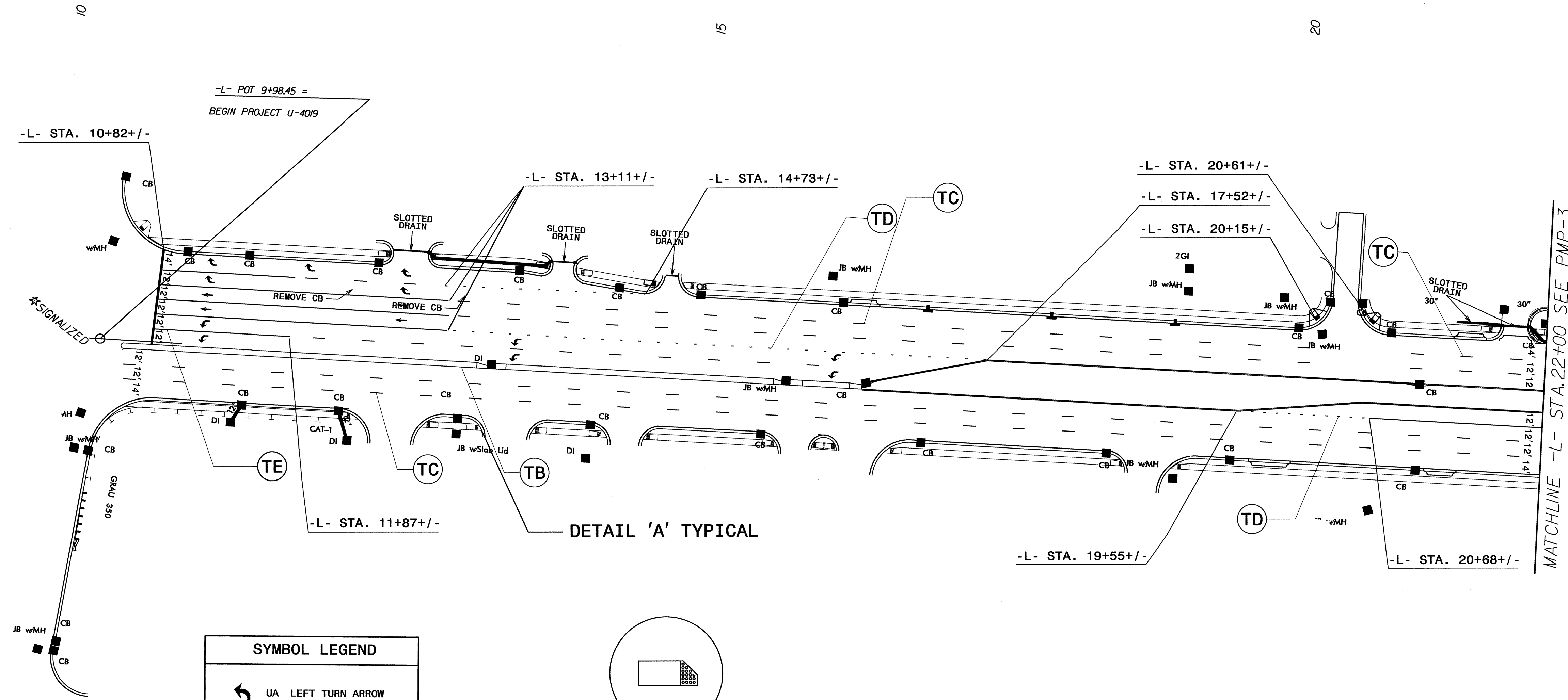
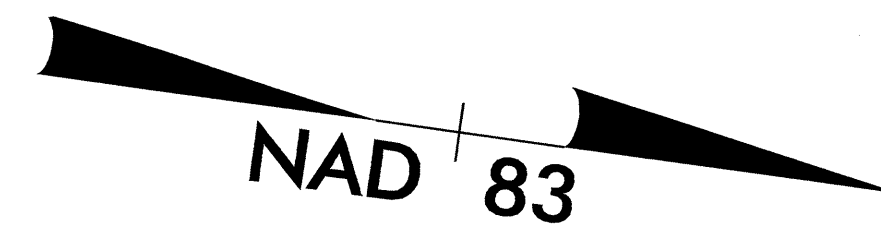

DETAIL 'A' TYPICAL

SYMBOL LEGEND	
	UA LEFT TURN ARROW
	UB RIGHT TURN ARROW
	UC STRAIGHT ARROW

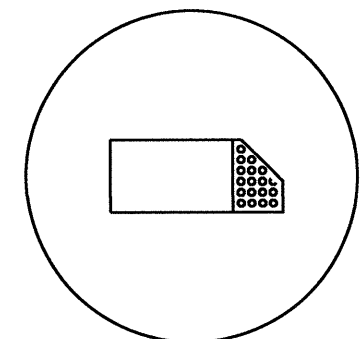

DETAIL 'A'

NOTES: SEE 2006 NCDOT ROADWAY STANDARD DRAWING 1205.02, 1205.04, 1205.08 AND 1250.01, FOR PAVEMENT MARKING, MARKERS, SYMBOLS AND CHARACTER LOCATIONS.

**PAVEMENT MARKING DETAIL**

TIP NO. U-4019	SHEET NO. PMP-3
APPROVED: <i>Wm. J. Aloud</i>	
DATE: 4-5-11	
SEAL	

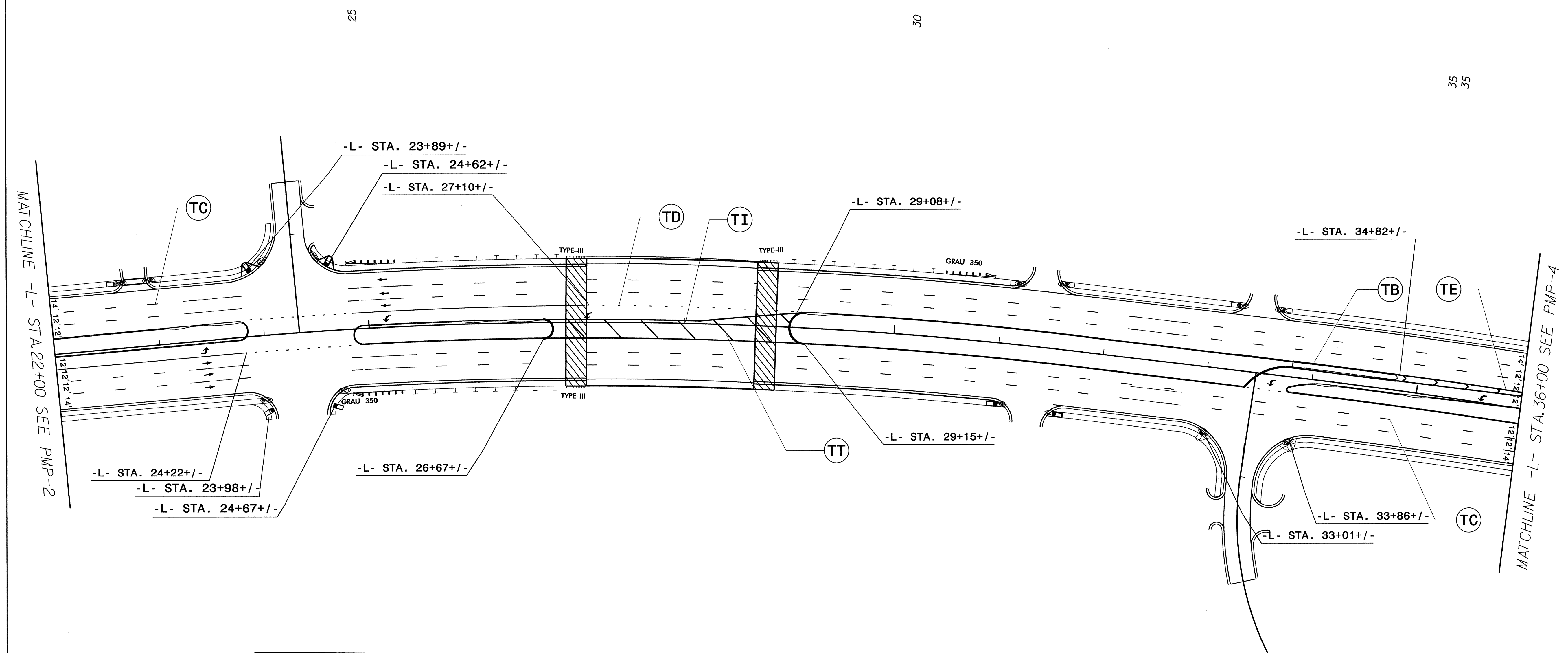
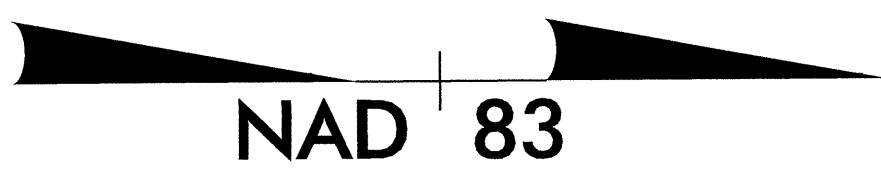

MATCHLINE -L- STA. 22+00 SEE PMP-2

MATCHLINE -L- STA. 36+00 SEE PMP-4

SYMBOL LEGEND	
	UA LEFT TURN ARROW
	UC STRAIGHT ARROW



NOTES: SEE 2006 NCDOT ROADWAY STANDARD DRAWING 1205.02, 1205.04, 1205.08 AND 1250.01, FOR PAVEMENT MARKING, MARKERS, SYMBOLS AND CHARACTER LOCATIONS.

**PAVEMENT MARKING DETAIL**

04-11-2011 10:15:10  
C:\Users\jacob\Documents\CADD\PMU-4019.pmp3.dgn  
browlin

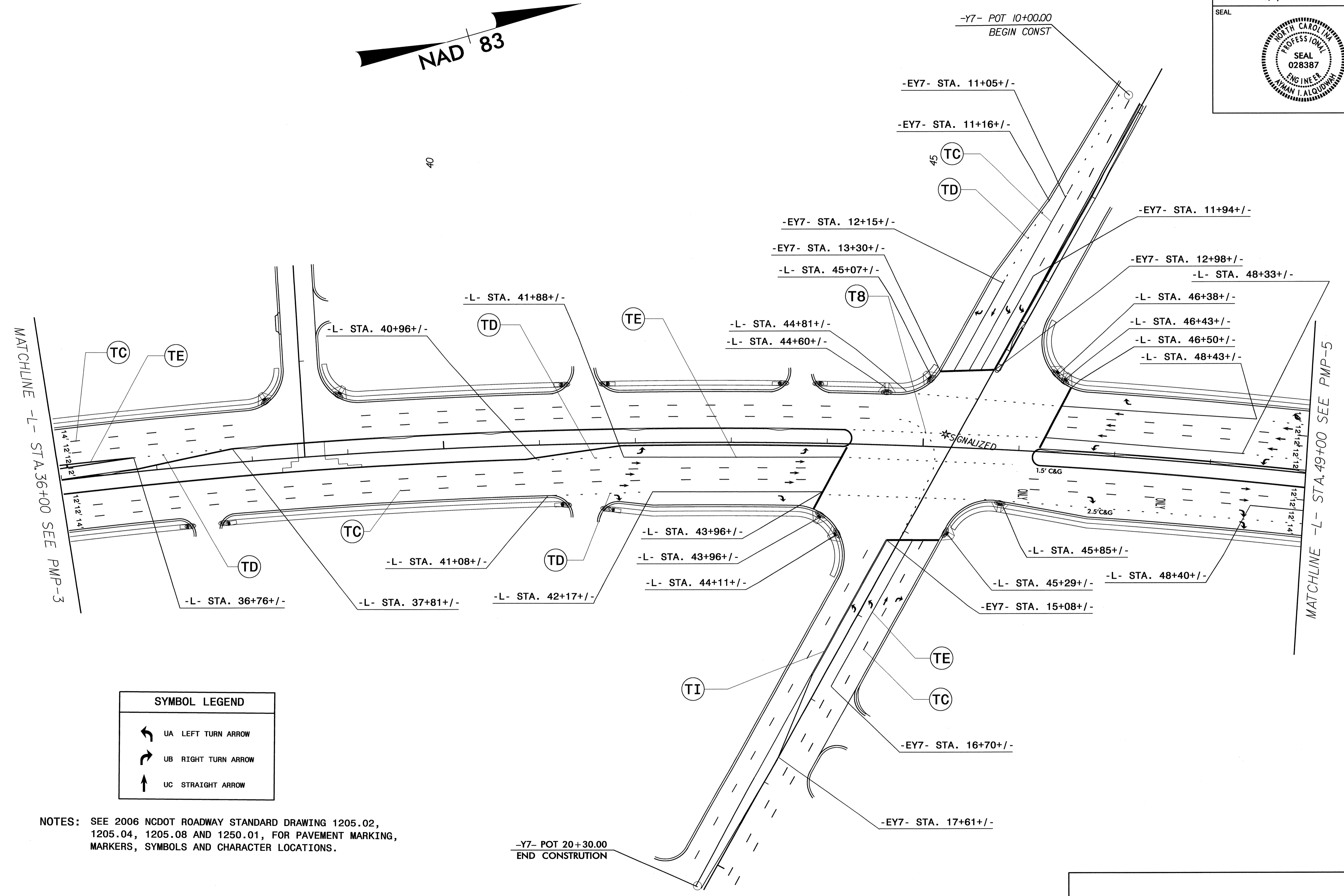
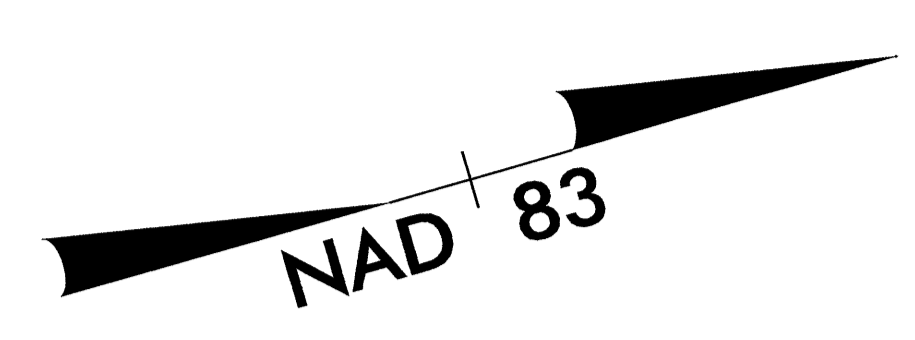
TIP NO. U-4019	SHEET NO. PMP-4
APPROVED: <i>[Signature]</i>	
DATE: 4/6/11	
SEAL	
	



SYMBOL LEGEND	
	UA LEFT TURN ARROW
	UB RIGHT TURN ARROW
	UC STRAIGHT ARROW

NOTES: SEE 2006 NCDOT ROADWAY STANDARD DRAWING 1205.02, 1205.04, 1205.08 AND 1250.01, FOR PAVEMENT MARKING, MARKERS, SYMBOLS AND CHARACTER LOCATIONS.

**PAVMENT MARKING DETAIL**

D:\PMP\2011\5458  
 PMP-4.dwg  
 4/6/11  
 Man I. Aloudini



TIP NO. U-4019	SHEET NO. PMP-6
APPROVED: <i>[Signature]</i>	
DATE: 4/26/11	
SEAL	

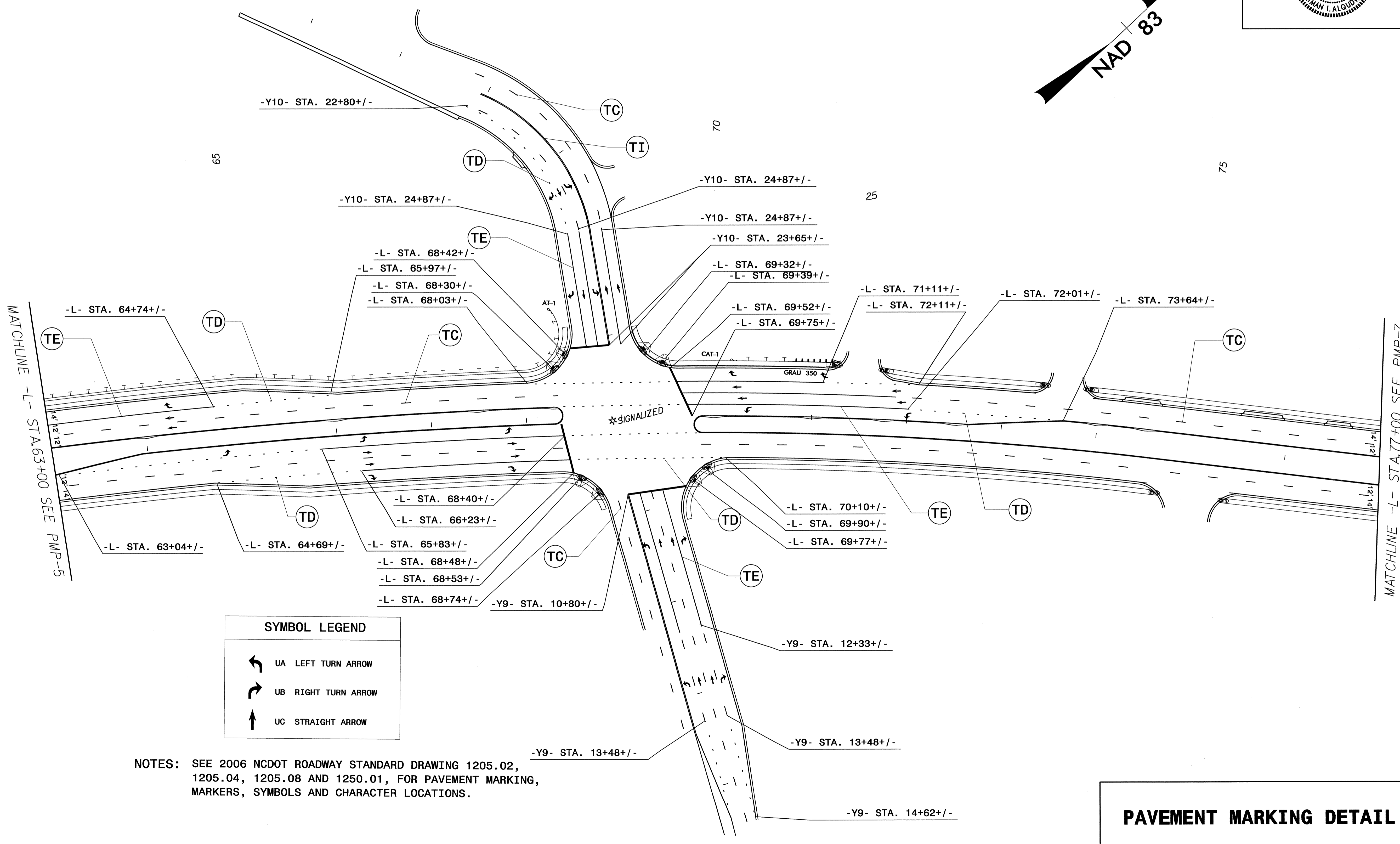
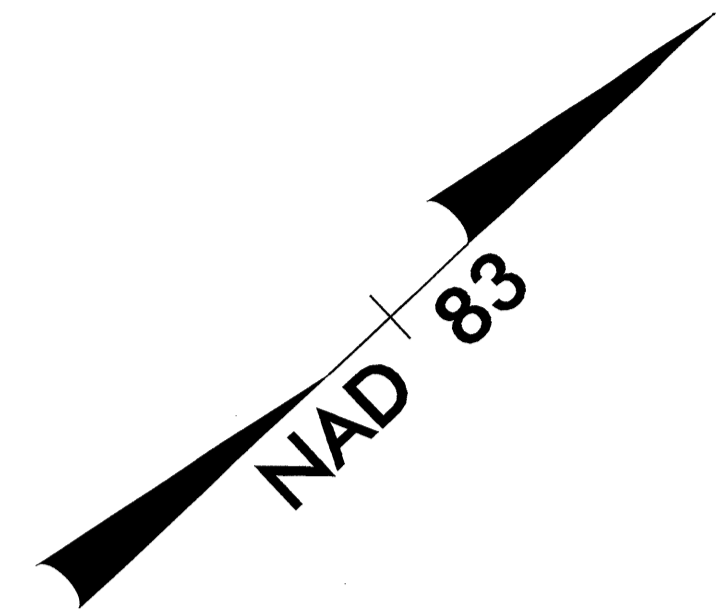

SYMBOL LEGEND	
	UA LEFT TURN ARROW
	UB RIGHT TURN ARROW
	UC STRAIGHT ARROW

NOTES: SEE 2006 NCDOT ROADWAY STANDARD DRAWING 1205.02, 1205.04, 1205.08 AND 1250.01, FOR PAVEMENT MARKING, MARKERS, SYMBOLS AND CHARACTER LOCATIONS.

**PAVEMENT MARKING DETAIL**

06-APP-2011(6)08  
R:\Projects\Signage\CADD\PMU-U-4019\_Sgn\_PMP-6.dgn  
browlin

MATCHLINE -L- STA.63+00 SEE PMP-5

MATCHLINE -L- STA.77+00 SEE PMP-7

TIP NO. U-4019	SHEET NO. PMP-7
APPROVED: <i>[Signature]</i>	
DATE: 4-5-11	
SEAL	

SYMBOL LEGEND	
	UA LEFT TURN ARROW

NOTES: SEE 2006 NCDOT ROADWAY STANDARD DRAWING 1205.02, 1205.04, 1205.08 AND 1250.01, FOR PAVEMENT MARKING, MARKERS, SYMBOLS AND CHARACTER LOCATIONS.

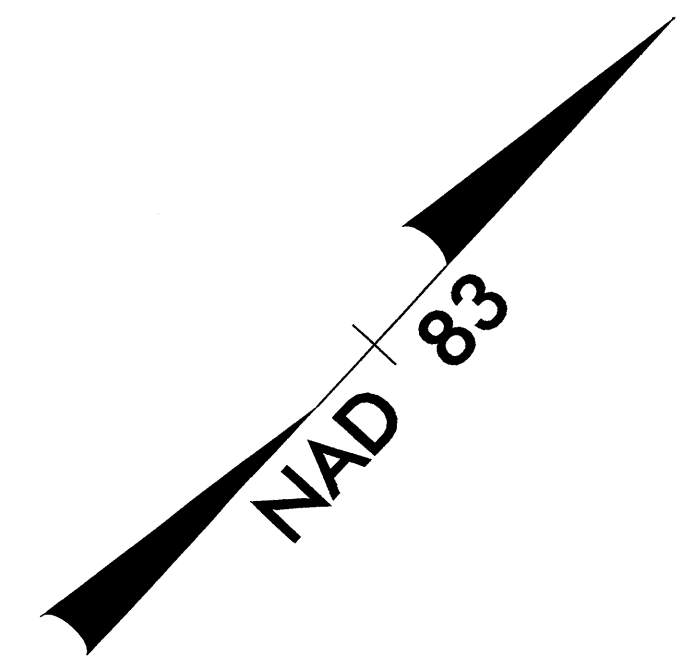

80

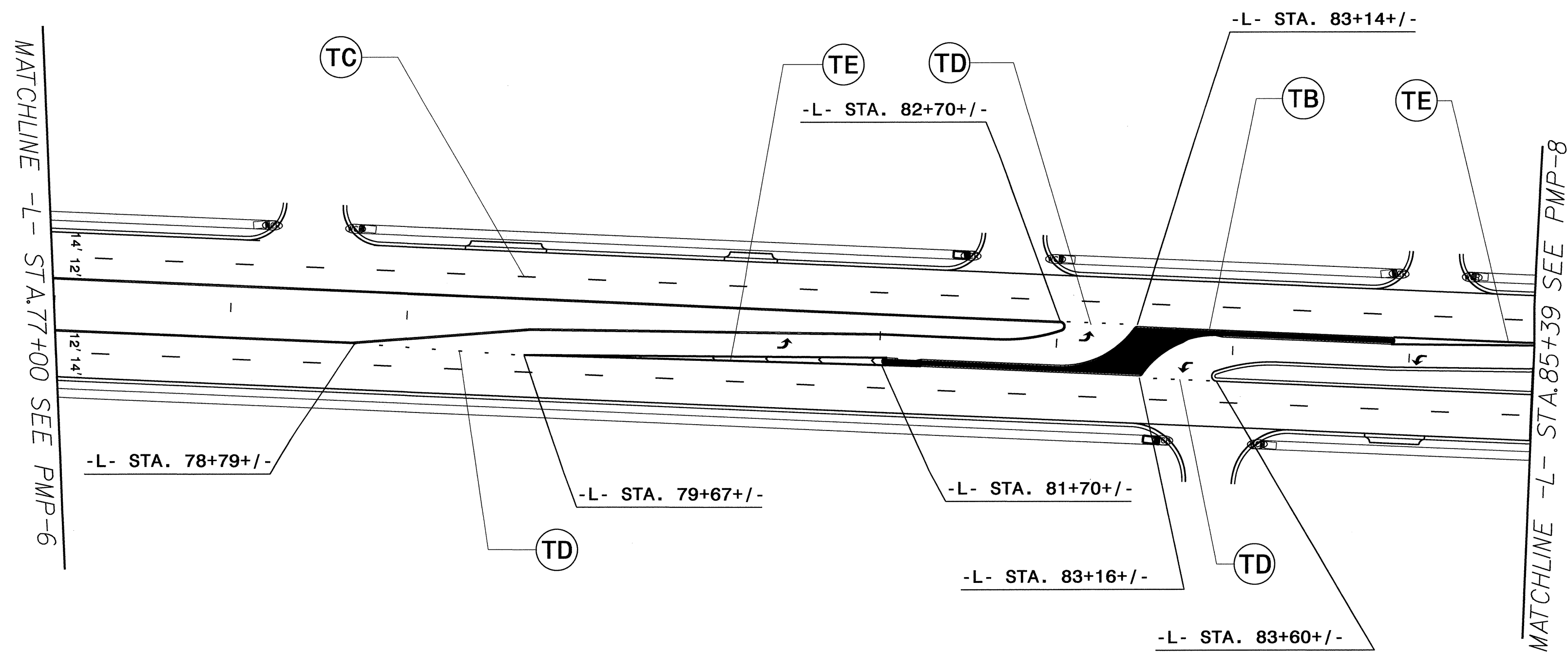

**PAVEMENT MARKING DETAIL**

04-APR-2011 14:45  
R:\Prof\c\Sign\109\CADD\PMU\U-4019\_Sgn\_PMP-7.dgn  
browlin AL 4/27/11

SYMBOL LEGEND	
	UA LEFT TURN ARROW
	UB RIGHT TURN ARROW
	UC STRAIGHT ARROW

NOTES: SEE 2006 NCDOT ROADWAY STANDARD DRAWING 1205.02, 1205.04, 1205.08 AND 1250.01, FOR PAVEMENT MARKING, MARKERS, SYMBOLS AND CHARACTER LOCATIONS.

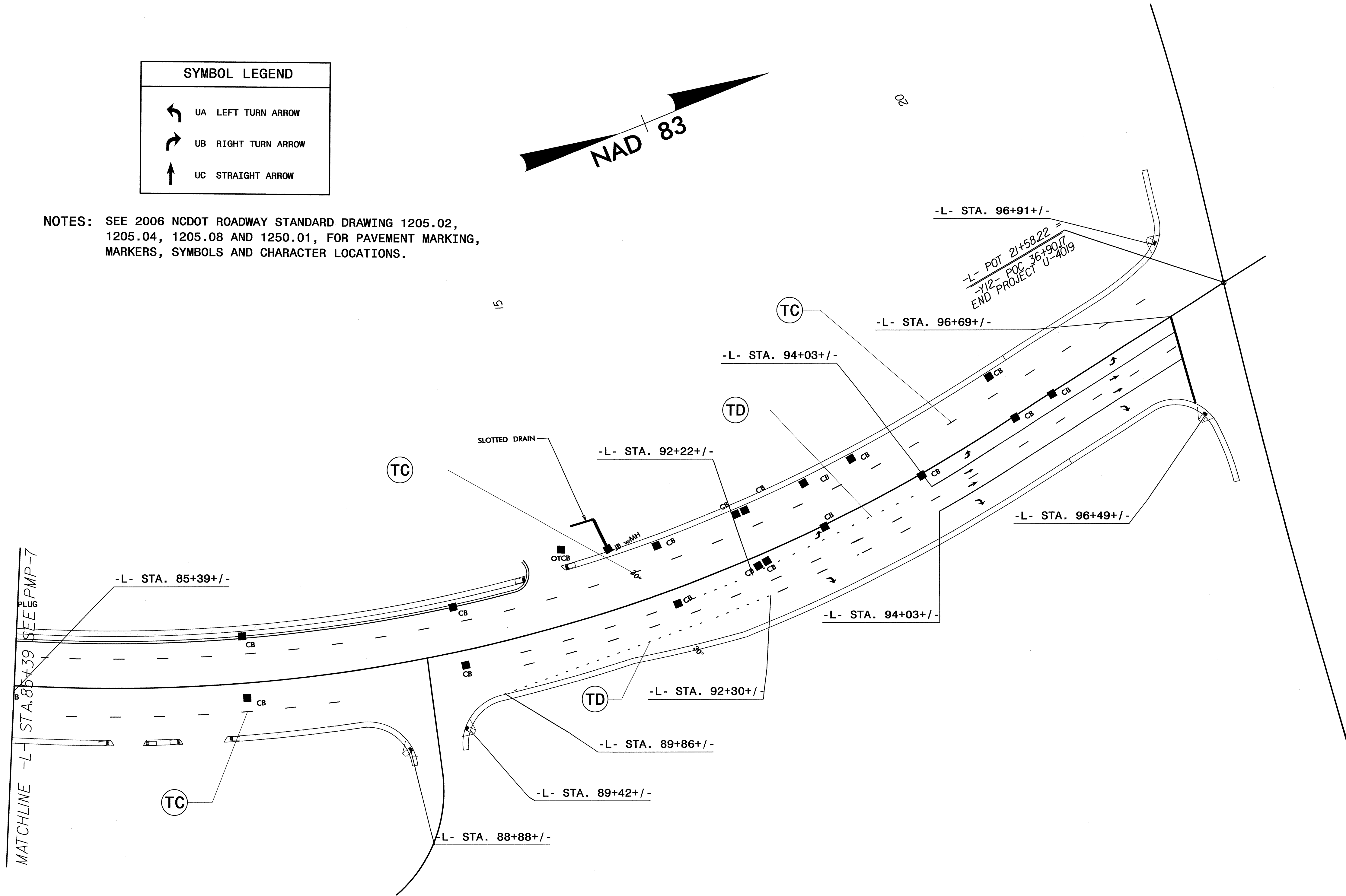

3-MAR-2011 13:02  
 R:\Traffic\Sigap109\ADD\PMF\U-4019\_Sgn\_PMP-8.dgn  
 browlin AT 11:27:51

**PAVEMENT MARKING DETAIL**