

STATE OF NORTH CAROLINA
DIVISION OF HIGHWAYS

**UTILITY CONSTRUCTION PLANS
BURKE COUNTY**

**LOCATION: MORGANTON - NC 18(STERLING STREET) AND
I-40 INTERCHANGE**

**TYPE OF WORK: WATER, SANITARY SEWER AND
ELECTRIC POWER DUCT BANK**

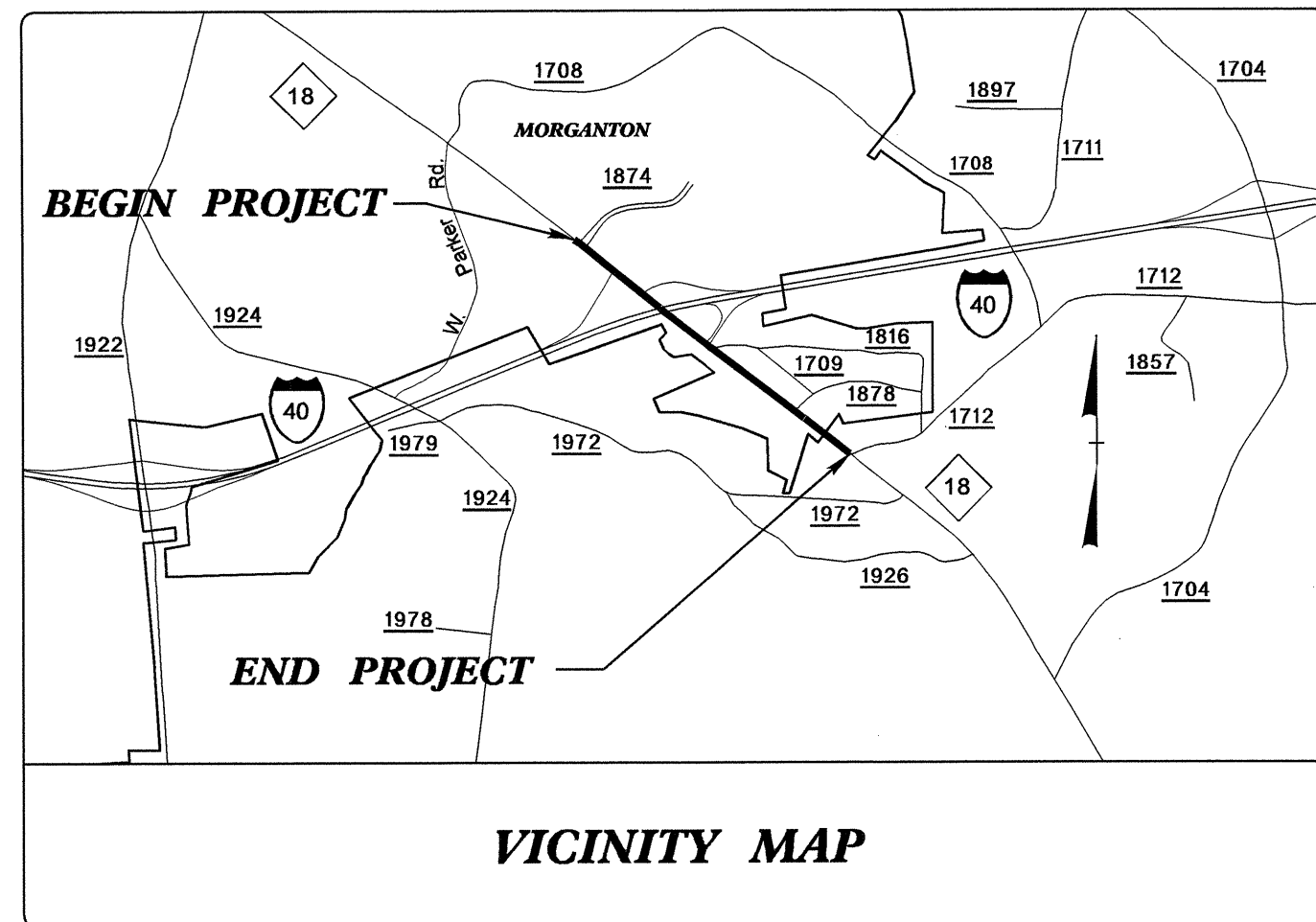

VICINITY MAP

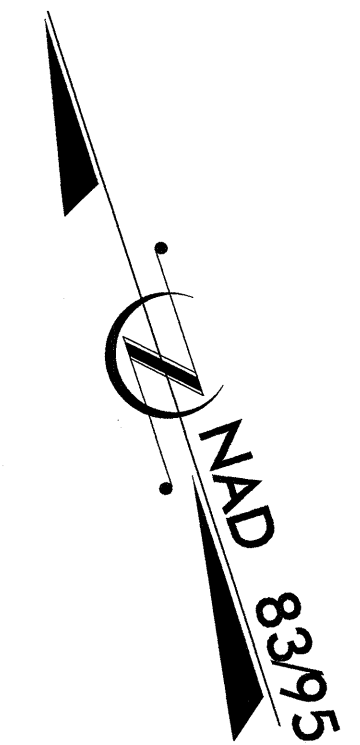

STA. 12+80.00 -L- BEGIN TIP PROJECT U-2550B

STA. 46+65.00 -L- END TIP PROJECT U-2550B

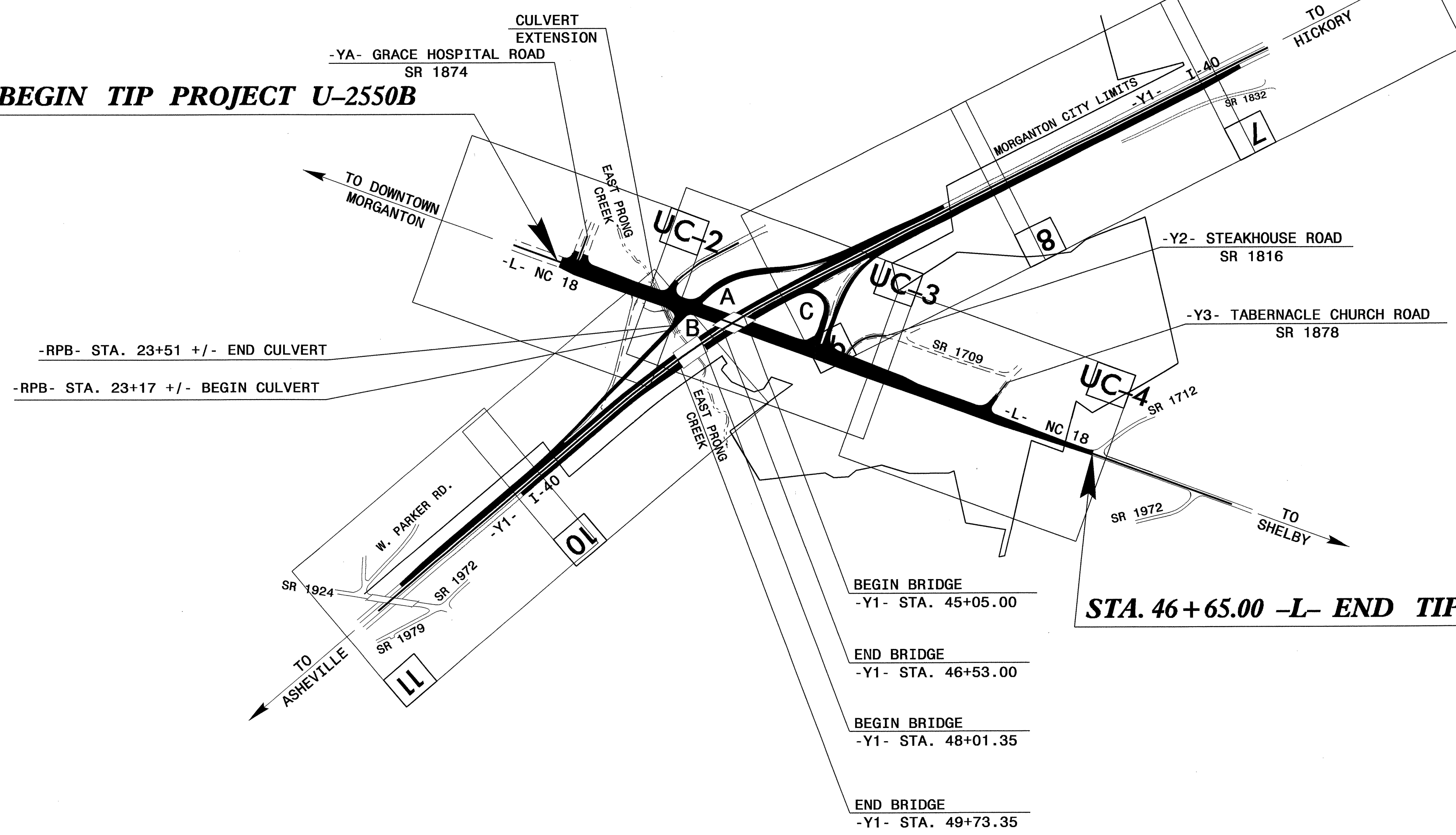

TIP PROJECT: U-2550B

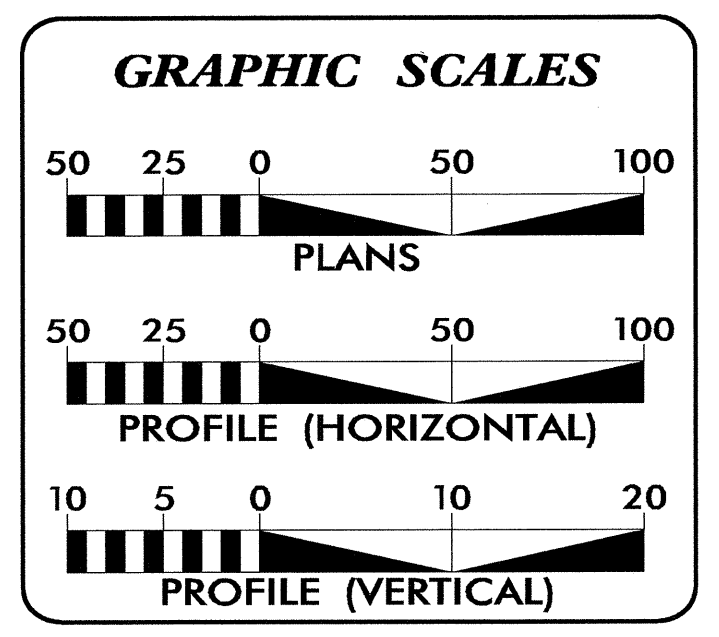

INDEX OF SHEETS

SHEET NO.	DESCRIPTION
UC-1	TITLE SHEET
UC-2 THRU UC-4	UTILITY CONSTRUCTION PLAN SHEETS
UC-5	PROFILE SHEET(S)
UC-6	DETAILS SHEET(S)

WATER AND SEWER OWNERS ON PROJECT

(1) WATER : CITY OF MORGANTON
(2) SANITARY SEWER : CITY OF MORGANTON
(3) ELECTRIC POWER : CITY OF MORGANTON

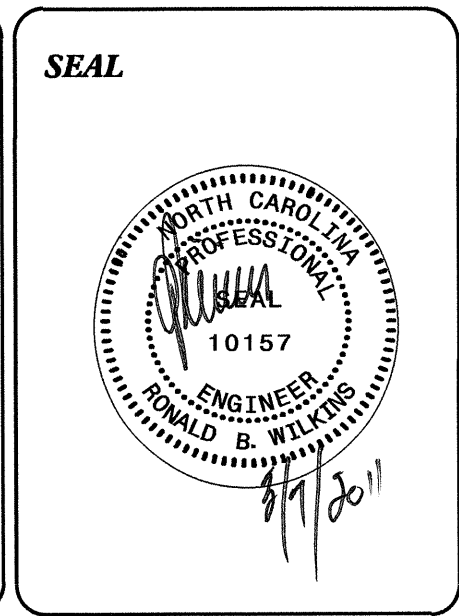

PREPARED IN THE OFFICE OF:
**DIVISION OF HIGHWAYS
UTILITIES ENGINEERING
SECTION**

1591 MAIL SERVICES CENTER
RALEIGH NC 27699-1591
PHONE (919) 250-4128
FAX (919) 250-4119

Roger Worthington, P.E. UTILITIES SECTION ENGINEER
R.B. WILKINS, P.E. UTILITIES SQUAD LEADER PROJECT ENGINEER
JONG-TAE YOON UTILITIES PROJECT DESIGNER

02-MAR-2011 09:49 R:\Utilities\RDY\UF\Proj\U2550B_UT_1.UCL.TSH.dgn \$\$\$USERNAME\$\$\$



UTILITY CONSTRUCTION

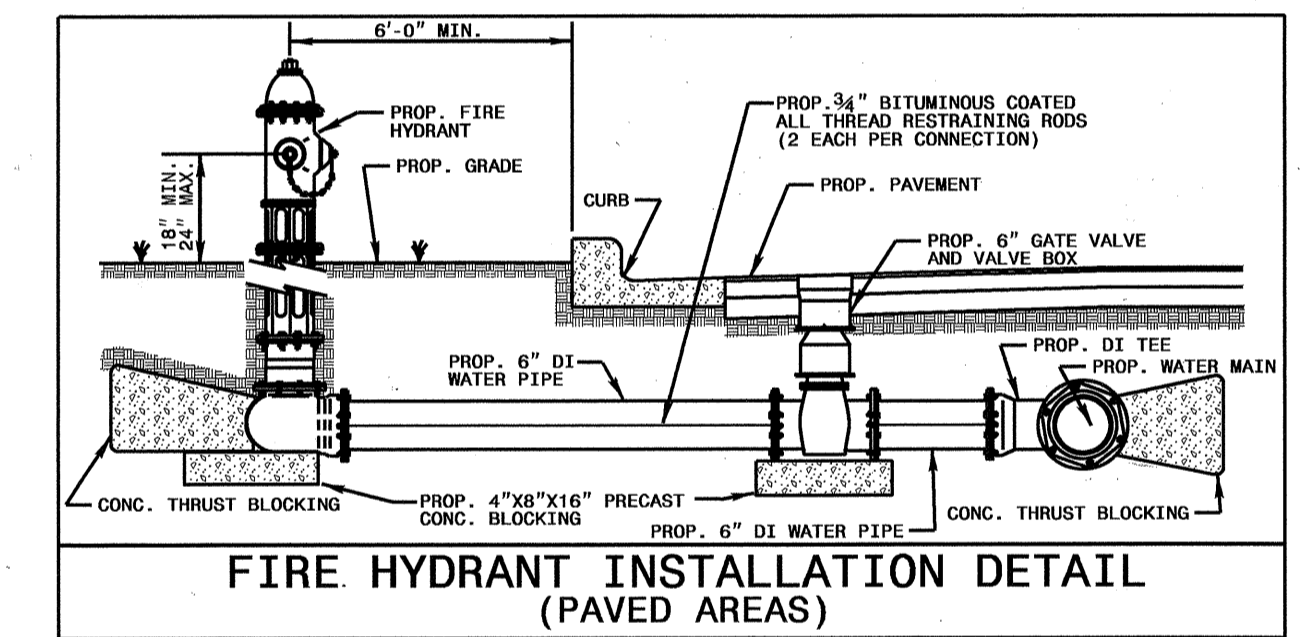
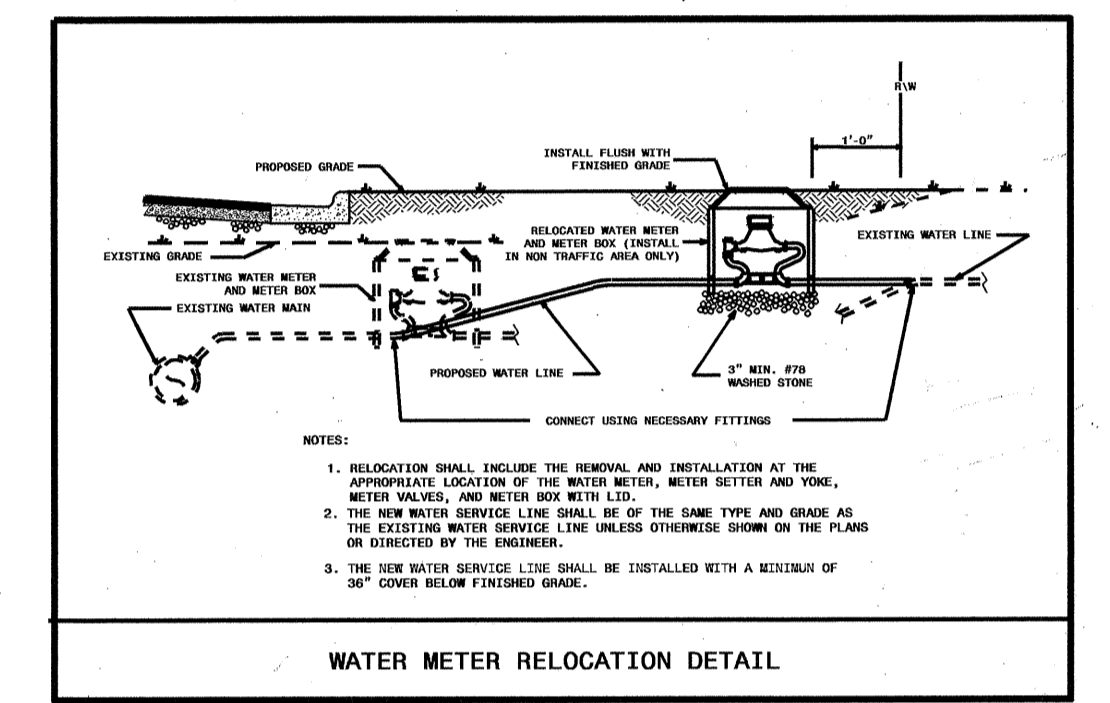
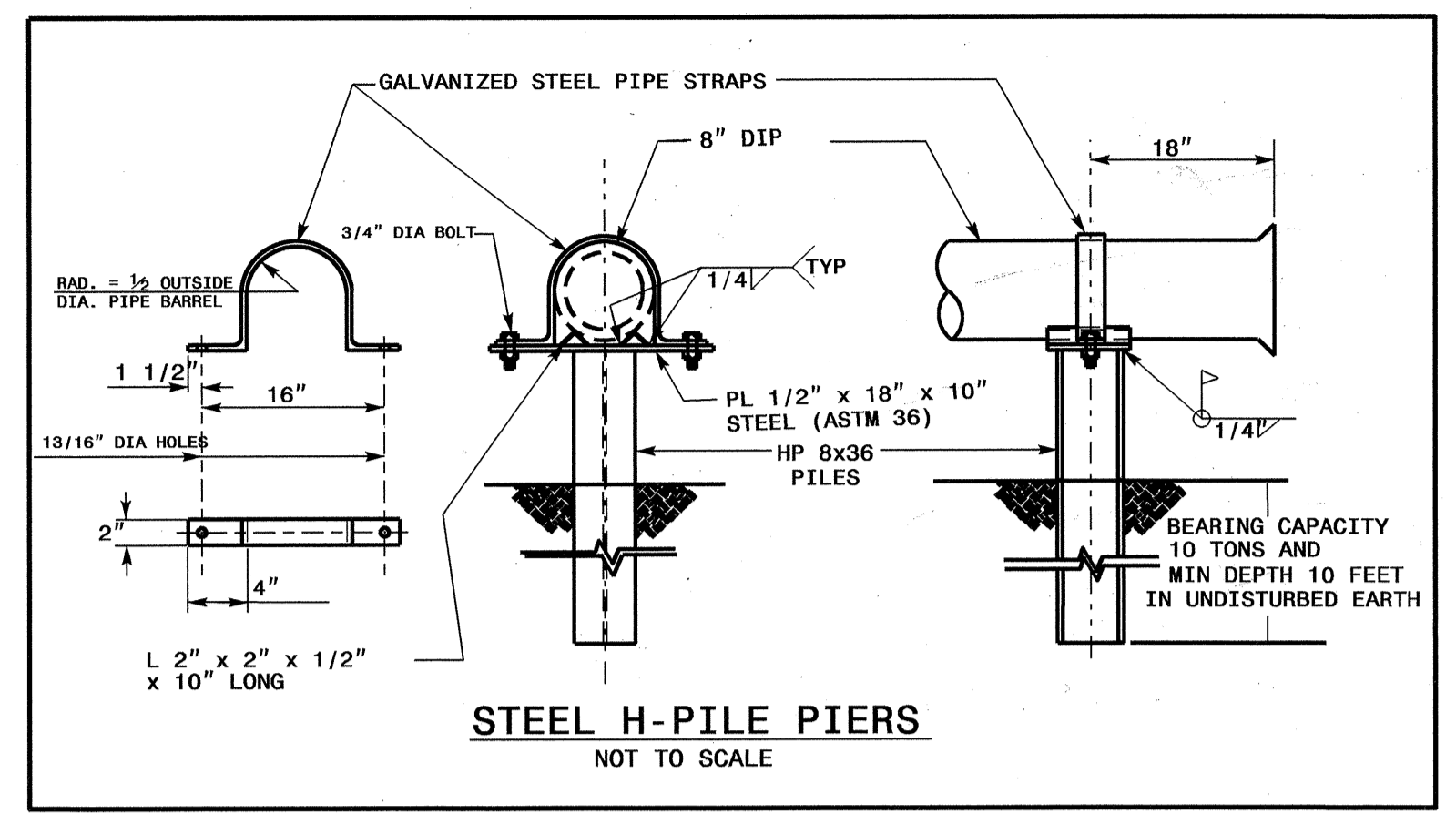

MANHOLE TRENCH WITH AT TOP OF PIPE			
MANHOLE TYPE	TRENCH WITH SLOPED SIDES	TRENCH WITH VERTICAL SIDES	TRENCH WITH SLOPED SIDES
TYPE 1	TYPE 2	TYPE 3	TYPE 4

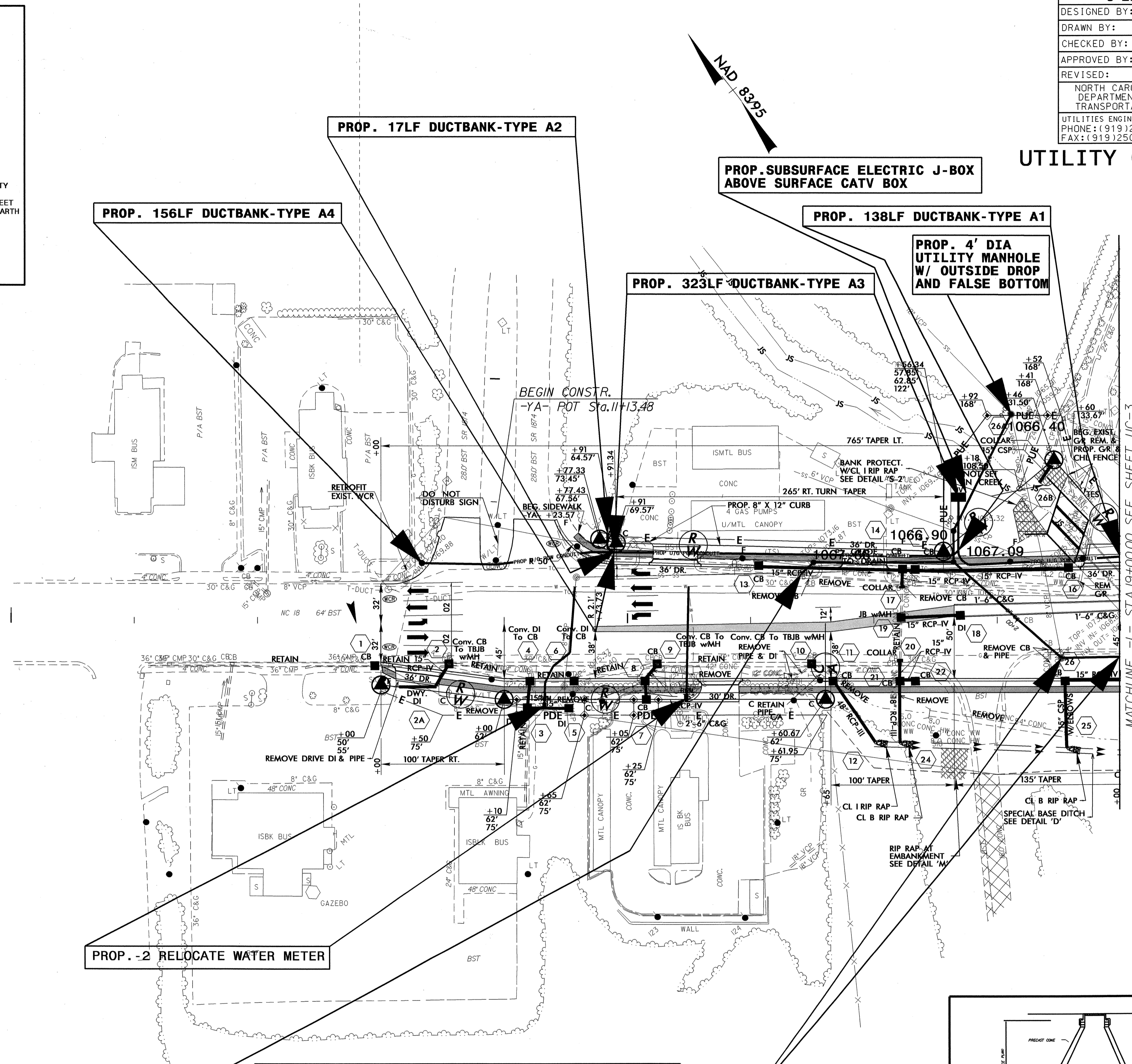
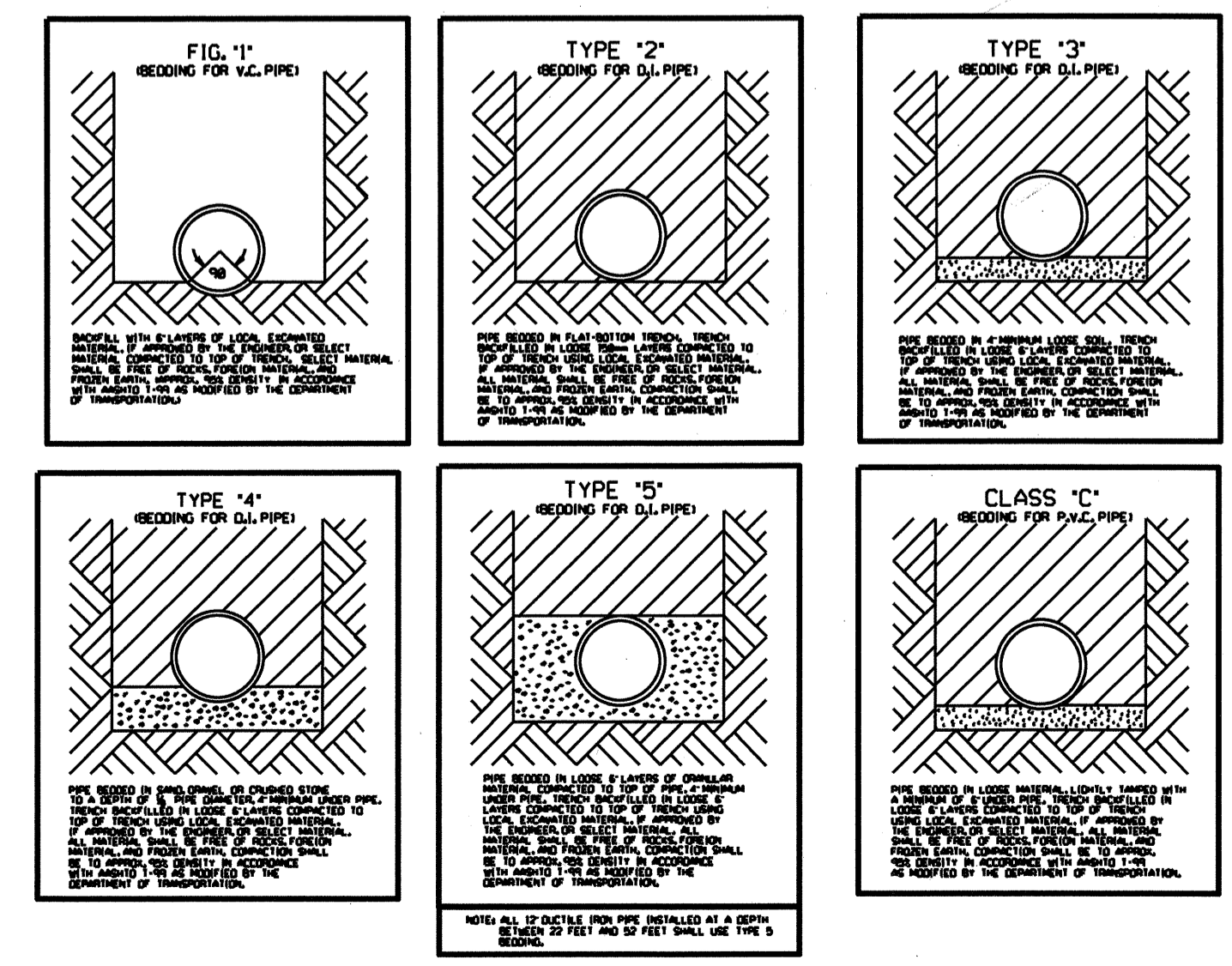

- PROP. - 55LF 6" SANITARY GRAVITY SEWER
- PROP. - 422LF 8" SANITARY GRAVITY SEWER
- PROP. - 3 4' DIA UTILITY MANHOLE
- PROP. - 298LF ABANDON 8" UTILITY PIPE
- PROP. - 2 ABANDON UTILITY MANHOLE
- PROP. - 32LF STEEL H-PILE PIERS

SANITARY GRAVITY SEWER PIPE MUST BE DUCTILE IRON PIPE W/ CERAMIC EPOXY INTERIOR COATING

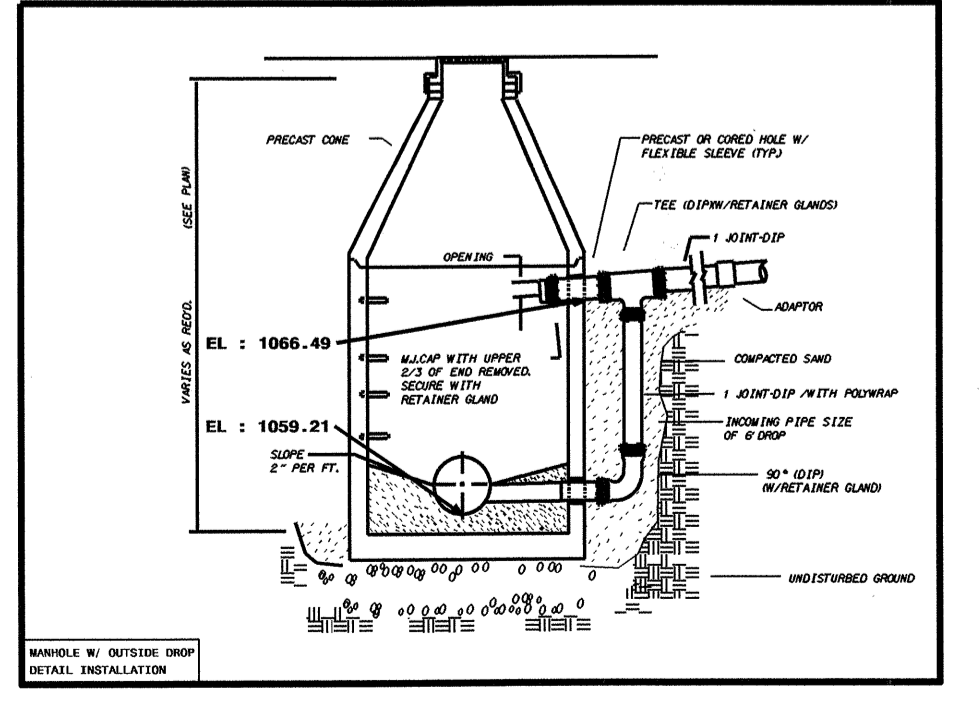

5/14/99
 13-APR-2011 11:54
 R:\Utilities\Draw\U-2550B\U-2550B_UC-2_PSH.dgn

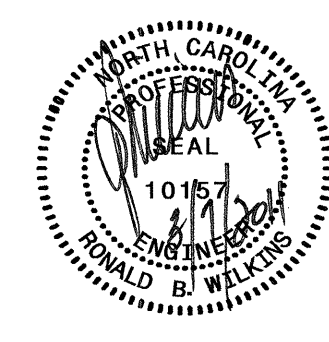
PROJECT REFERENCE NO.	SHEET NO.
U-2550B	UC-4
DESIGNED BY: JTY	
DRAWN BY: JTY	
CHECKED BY: RBW	
APPROVED BY: RBW	
REVISED:	
NORTH CAROLINA DEPARTMENT OF TRANSPORTATION UTILITIES ENGINEERING SEC. PHONE: (919) 250-4128 FAX: (919) 250-4119	
UTILITY CONSTRUCTION PLANS ONLY	

UTILITY CONSTRUCTION

**PROP. - 4 RELOCATE WATER METER
 PROP. - 1 RELOCATE FIRE HYDRANT
 PROP. - 1 2" WATER METER
 PROP. - 67LF 2" WATER LINE**

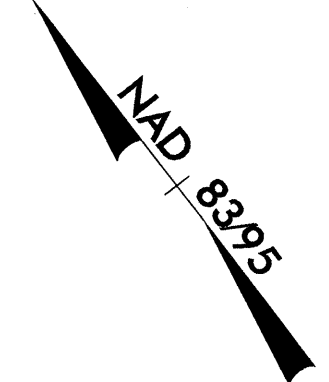

**END TIP PROJECT U-2550B
 -L- STA. 46+65.00**

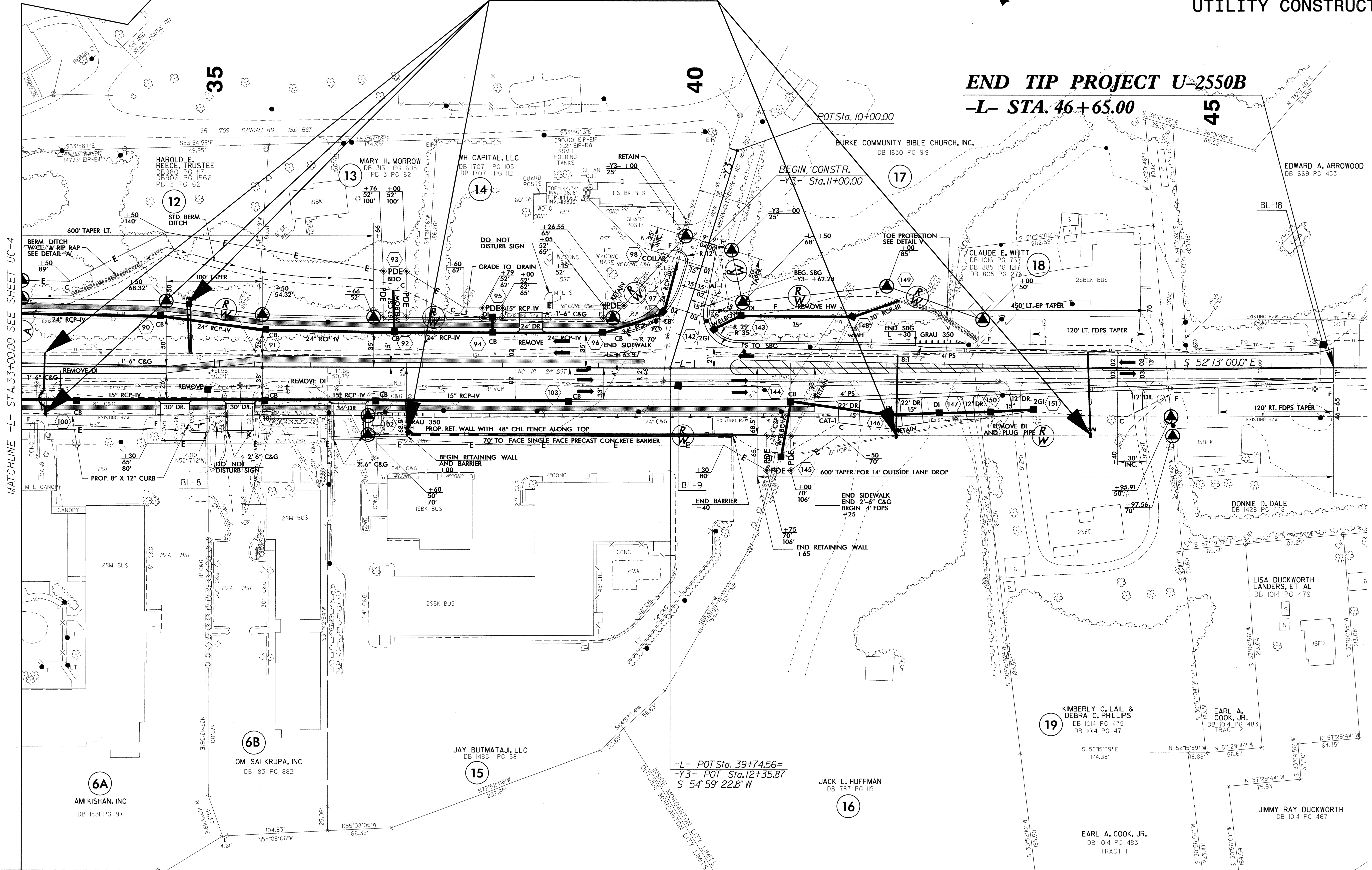

MATCHLINE -L- STA. 33+00.00 SEE SHEET UC-3

-L- POT Sta. 39+74.56=
 -Y3- POT Sta. 12+35.87
 S 54° 59' 22.8" W

5/14/99

R:\U\11-28-FEB-2011\1109-338315-FERMANE-UC-4-UC-4_psh.dgn

5/14/99

12-APR-2011 15:32
F:\Utilities\Ncd\Ut\Proj\U25508_UT_UC5.dgn

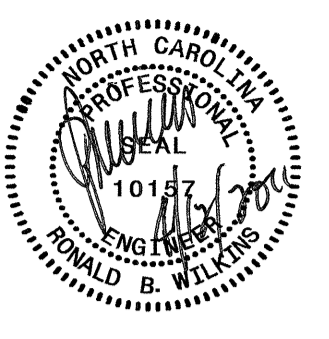
PROJECT REFERENCE NO.	SHEET NO.
U-2550B	UC-5
DESIGNED BY: JTY	
DRAWN BY: JTY	
CHECKED BY: RBW	
APPROVED BY: RBW	
REVISED:	NORTH CAROLINA DEPARTMENT OF TRANSPORTATION UTILITY CONSTRUCTION PLANS ONLY
NORTH CAROLINA DEPARTMENT OF TRANSPORTATION	
UTILITIES ENGINEERING SEC. PHONE: (919) 250-4128 FAX: (919) 250-4119	

UTILITY CONSTRUCTION

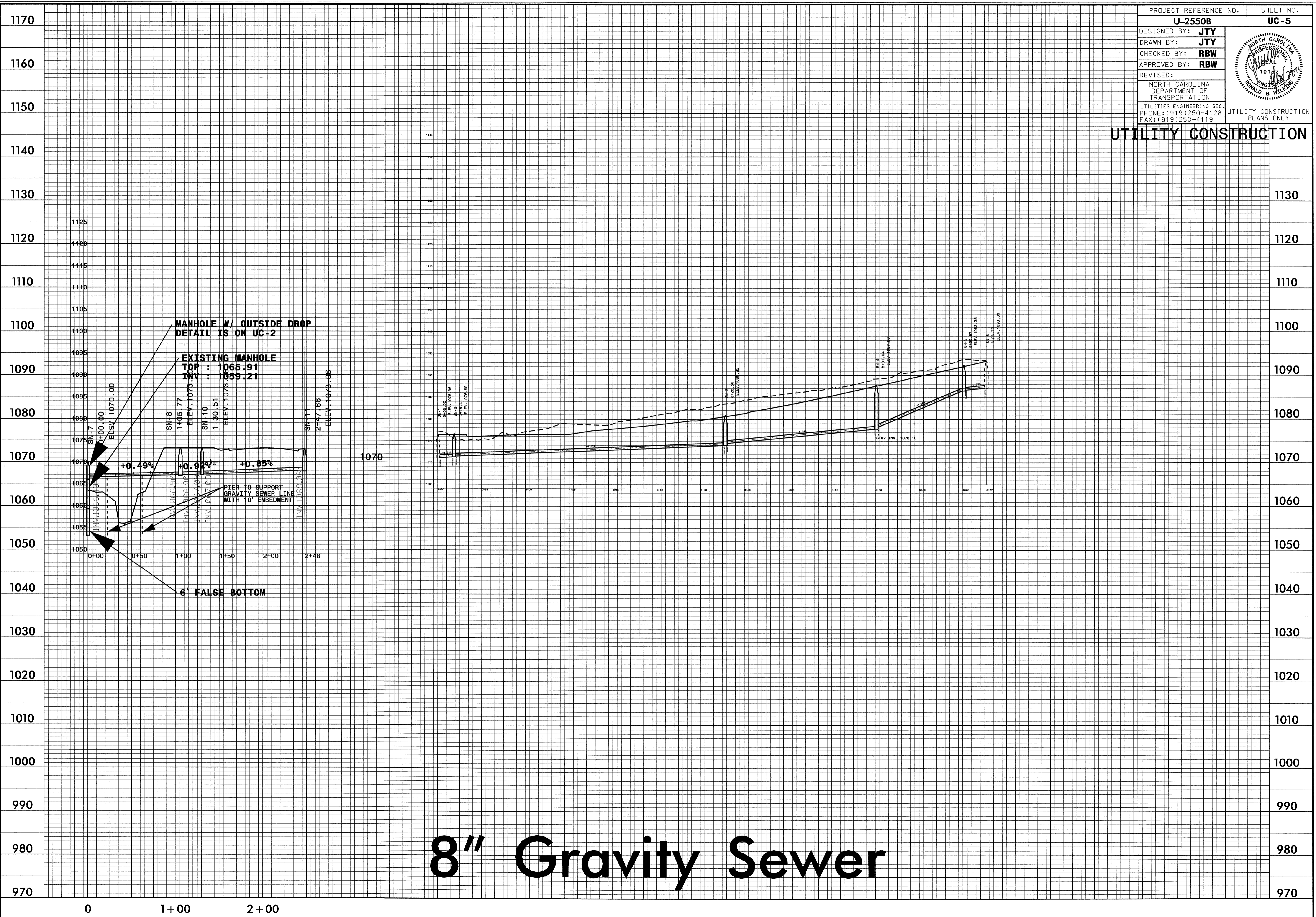

8" Gravity Sewer

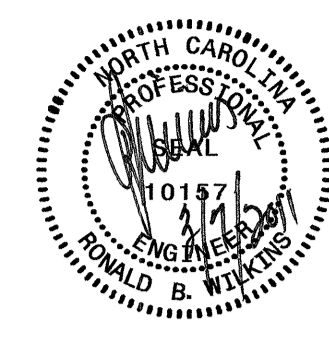
PROJECT REFERENCE NO. U-2550B	SHEET NO. UC-6
DESIGNED BY: JTY	
DRAWN BY: JTY	
CHECKED BY: RBW	
APPROVED BY: RBW	
REVISID:	
NORTH CAROLINA DEPARTMENT OF TRANSPORTATION UTILITIES ENGINEERING SEC. PHONE: (919) 250-4128 FAX: (919) 250-4119	



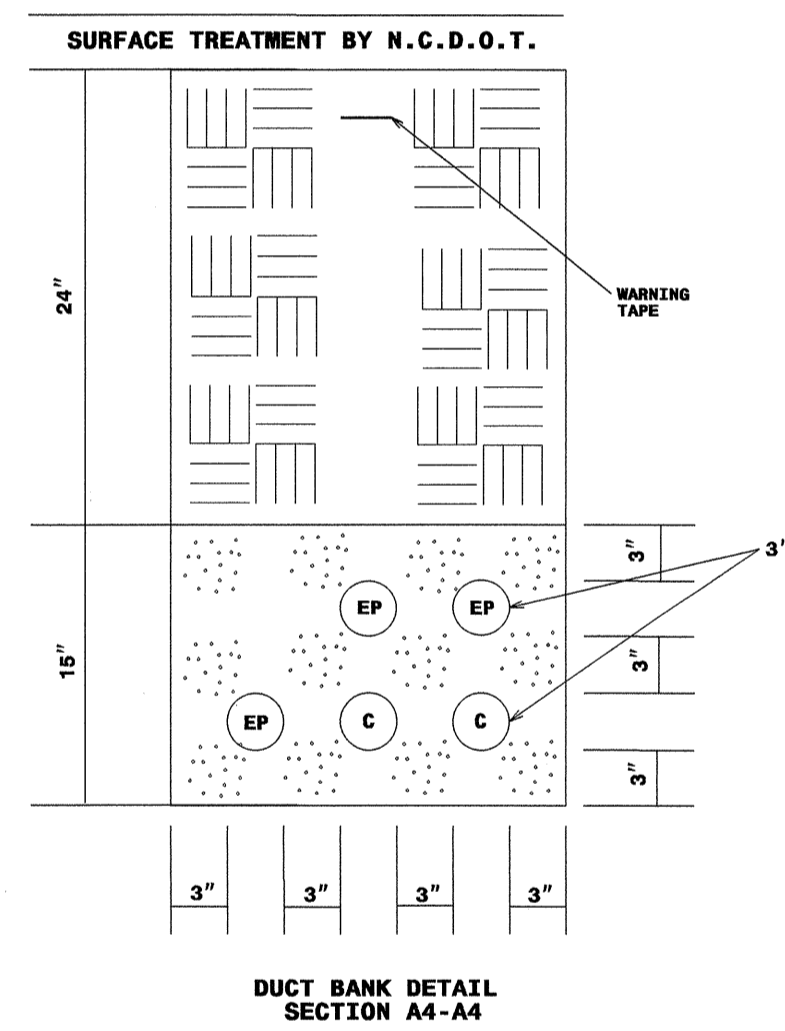
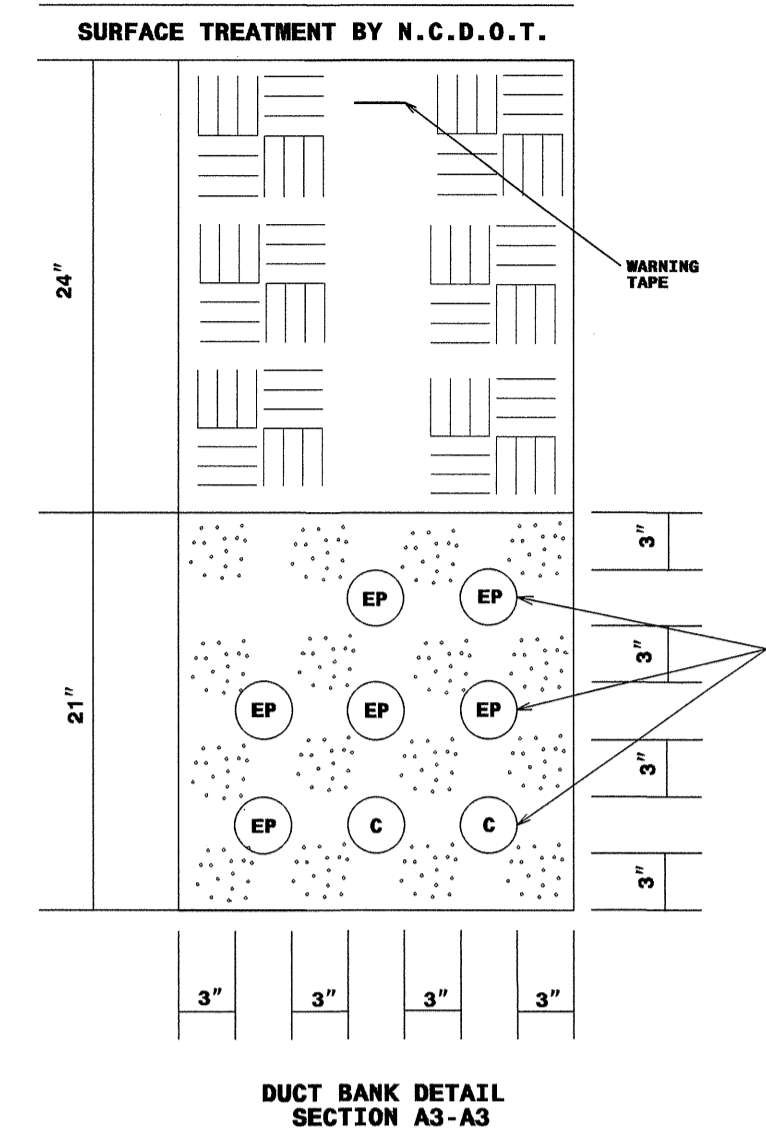
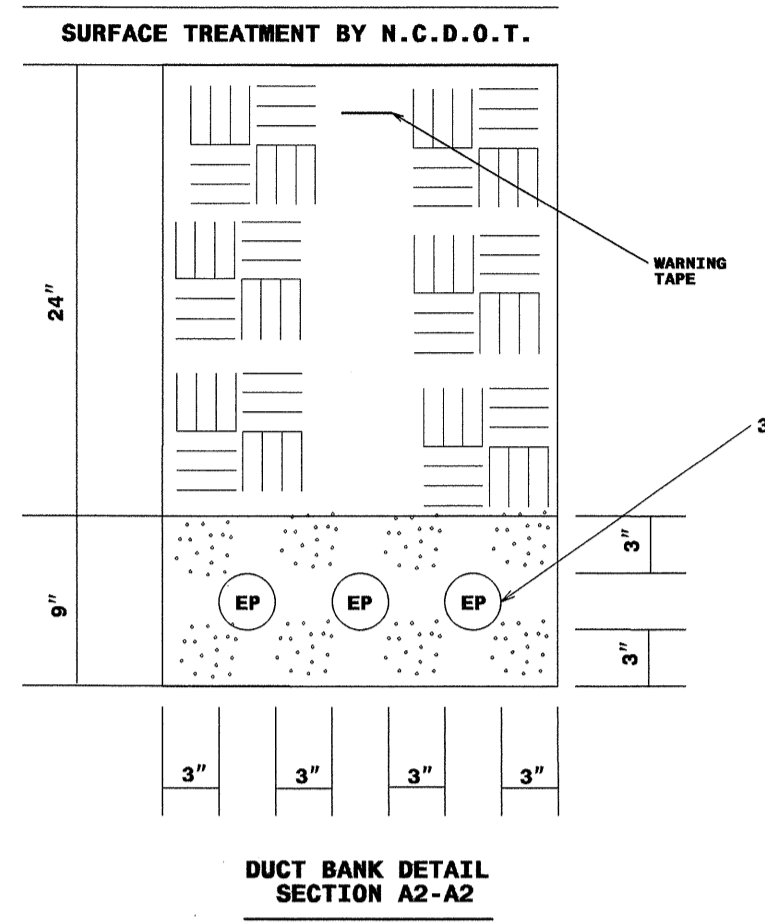
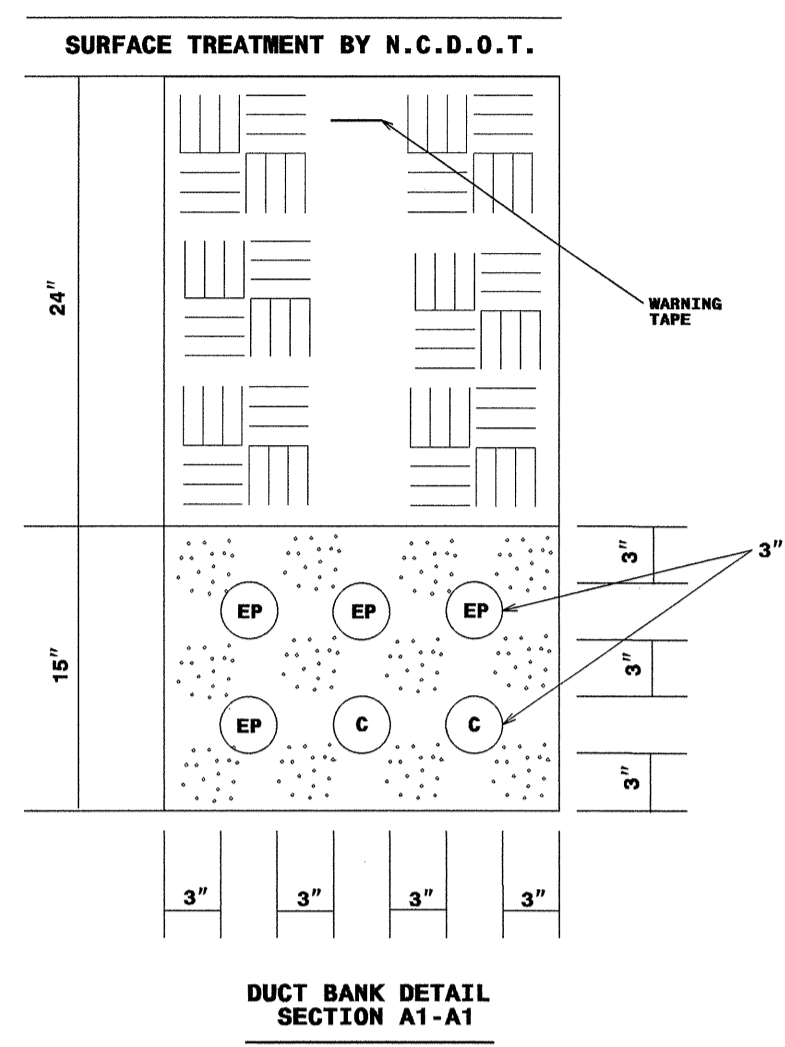

UTILITY CONSTRUCTION



GENERAL NOTES:

1. DIMENSIONS AND TYPES OF SURFACE TREATMENTS BY NCDOT IN ACCORDANCE WITH LOCAL AND STATE HIGHWAY REGULATIONS.
2. DUCT BANK CONFIGURATIONS ARE TYPICAL AND MAY VARY WITH SITE CONDITIONS.
3. SUBSURFACE CONDITIONS MAY VARY. ROUTE CONDUITS AS NEEDED TO CLEAR OBSTACLES. MAINTAIN SMOOTH RADIUS SWEEPS (ALL 90 DEGREE BENDS MUST HAVE A MINIMUM RADIUS OF 36-INCHES) WHILE ROUTING CONDUITS.
4. MAINTAIN ADEQUATE SPACE BETWEEN CONDUITS AS SHOWN IN CROSS SECTIONS. USE ADDITIONAL DUCT SPACERS IF NECESSARY.
5. 500 PSI FLOWABLE FILL SHALL BE USED FOR ALL DUCT BANK (UNLESS OTHERWISE SPECIFIED). FLOWABLE FILL SHALL HAVE A RED TINT MIXTURE ADDED PRIOR TO POURING.
6. MAINTAIN DEPTH OF BURIAL TO TOP OF FLOWABLE FILL ; ADJUST TRENCH SPACING ACCORDINGLY, WHILE MAINTAINING 3" FLOWABLE FILL COVER BETWEEN AND AROUND CONDUITS.
7. LOCATE ALL UNDERGROUND UTILITIES PRIOR TO EXCAVATION. USE EXTREME CAUTION IN THE VICINITY OF BURIED ELECTRIC, WATER, WASTEWATER, AND STEAM LINES (IF PRESENT)
8. FOLLOW ALL OSHA REQUIREMENTS FOR SLOPING AND SHORING EXCAVATIONS. USE EXTREME CAUTION WHEN TRENCHING TO AVOID CAVE-INS.
9. USE SCHEDULE 40 PVC FOR ALL DUCT BANK CONDUITS.
10. DUCT BANK SPACERS TO BE LOCATED EVERY 5'-0" ALONG LENGTH OF DUCT BANK.
11. BOTTOM OF TRENCH TO BE SMOOTH AND FREE OF ROCK AND DEBRIS. A FOUR (4) INCH BED OF SAND SHALL BE ADDED IF BOTTOM IS ROCKY.
12. ALL DIMENSIONS SHOWN ON THIS SHEET ARE MINIMUM. CONTRACTOR SHALL ACCOUNT FOR ADDITIONAL WIDTH AND DEPTH OF TRENCH REQUIRED FOR CONSTRUCTION METHODS.

LEGEND

-  ELECTRIC POWER
-  CATV
-  500 PSI FLOWABLE FILL (UNLESS OTHERWISE NOTED)
-  SELECTED BACKFILL

09/08/99

T.I.P. NO.	SHEET NO.
U-2550B	U0-1

STATE OF NORTH CAROLINA
DIVISION OF HIGHWAYS

**UTILITIES BY OTHERS PLANS
BURKE COUNTY**

**LOCATION: MORGANTON-NC18(STERLING STREET)
AND I-40 INTERCHANGE**

TYPE OF WORK: UTILITY WORK



TIP PROJECT: U-2550B

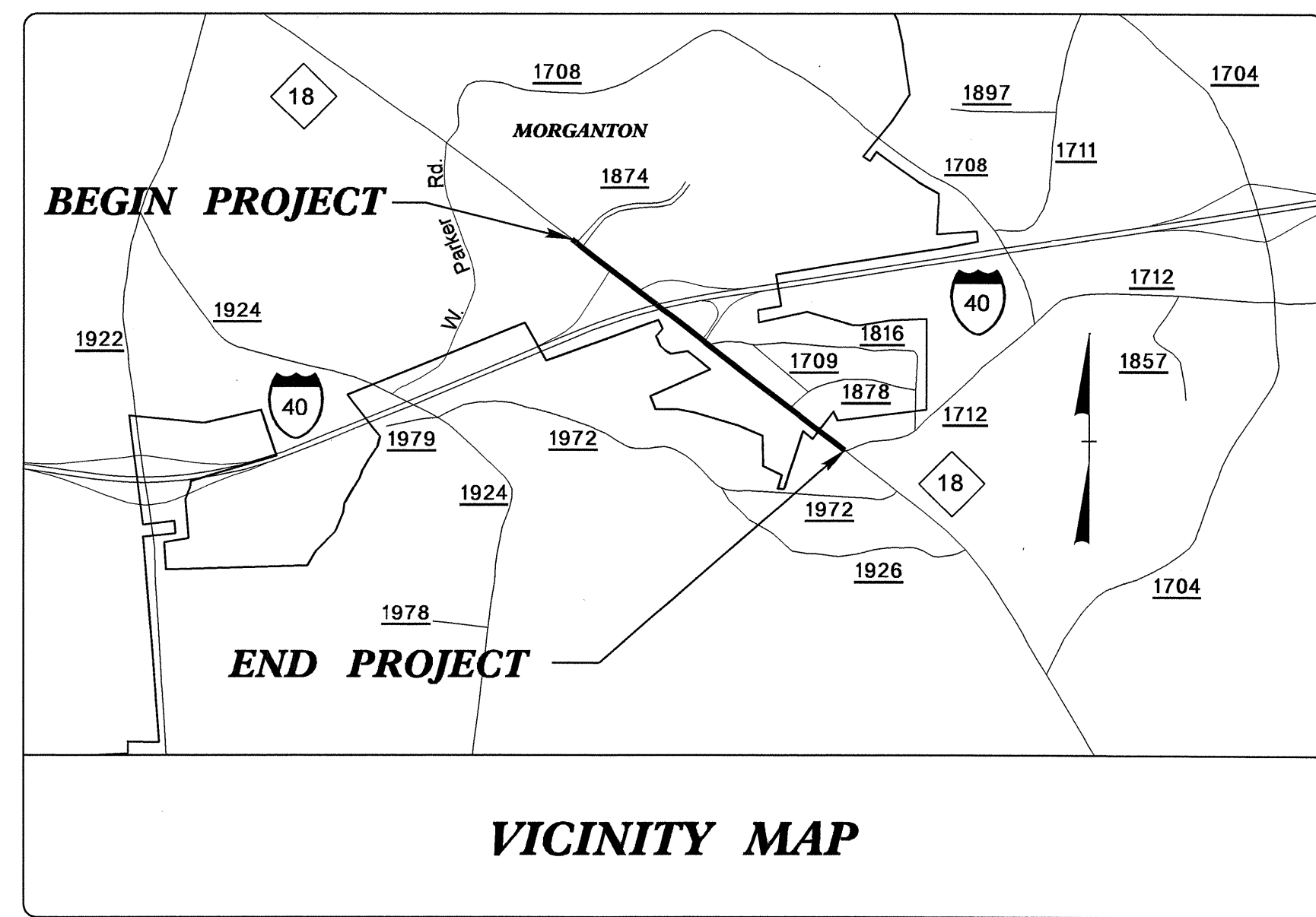

VICINITY MAP

STA. 12+80.00 -L- BEGIN TIP PROJECT U-2550B

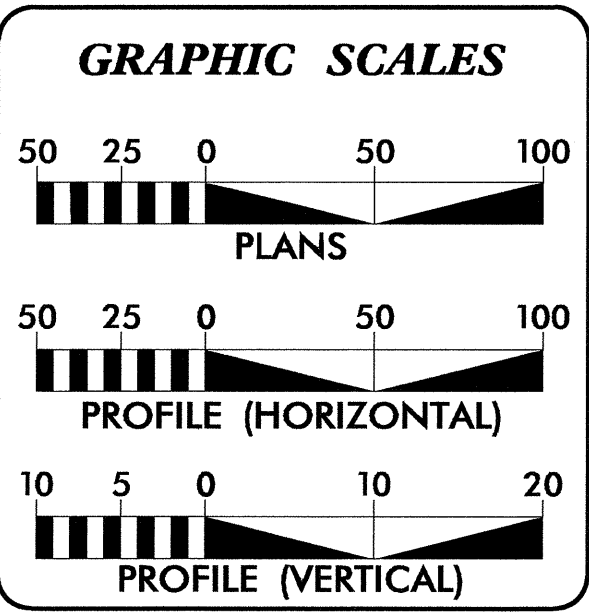
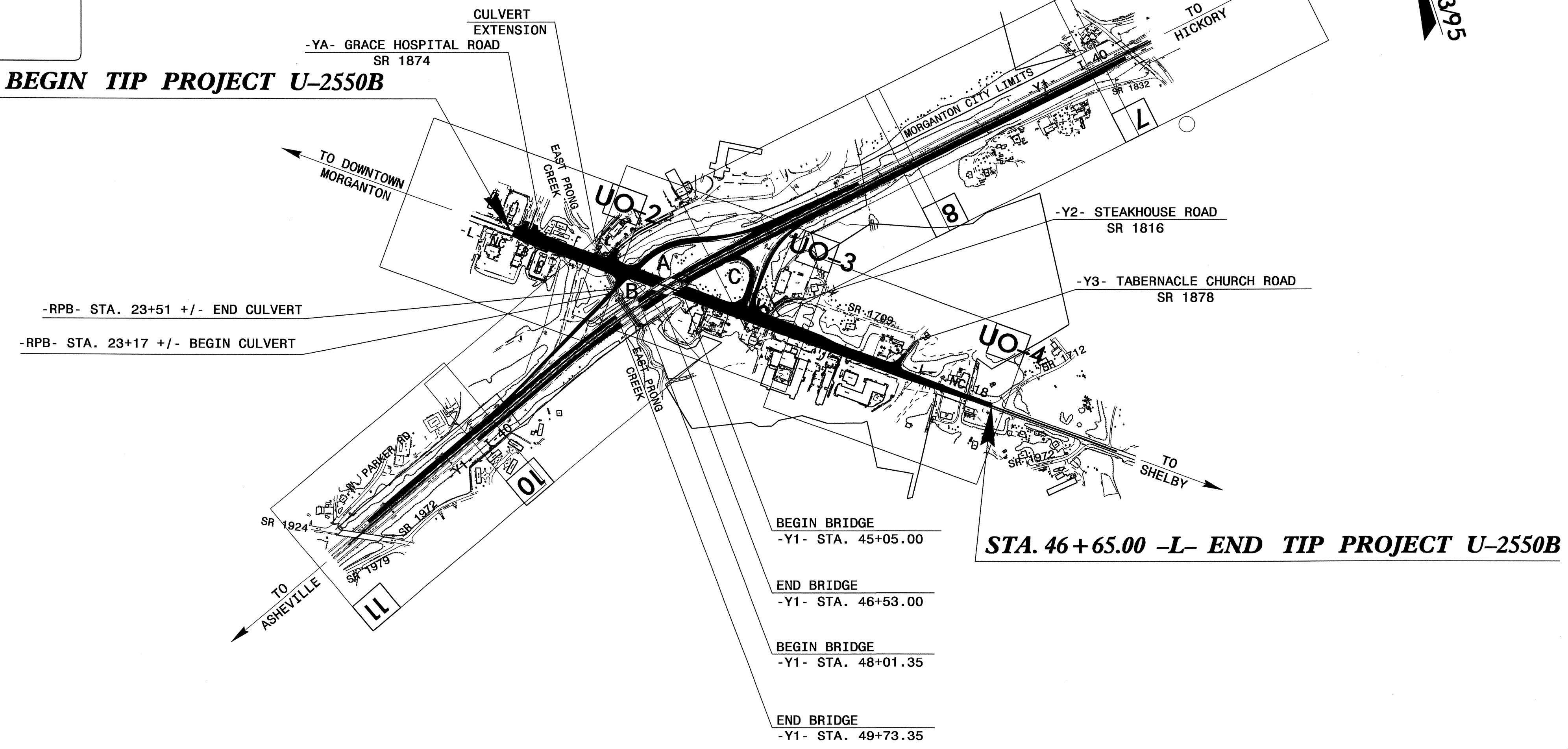

INDEX OF SHEETS

SHEET NO.	DESCRIPTION
U0-1	TITLE SHEET
U0-2 THRU U0-4	UTILITY BY OTHERS PLAN SHEETS

- UTILITY OWNERS ON PROJECT**
- (1) POWER : DUKE ENERGY, CITY OF MORGANTON
 - (2) TELEPHONE : TELICS/BELLSOUTH
 - (3) CABLE AND INTERNET : CoMPAS
 - (4) GAS : PIEDMONT NATURAL GAS

PREPARED IN THE OFFICE OF:
**DIVISION OF HIGHWAYS
UTILITIES ENGINEERING
SECTION**

1591 MAIL SERVICES CENTER
RALEIGH NC 27699-1591
PHONE (919) 250-4128
FAX (919) 250-4119

Roger Worthington, P.E. UTILITIES SECTION ENGINEER
R.B. WILKINS, P.E. UTILITIES SQUAD LEADER PROJECT ENGINEER
JONG-TAE YOON UTILITIES PROJECT DESIGNER

06-APR-2011 14:43 P:\Utilities\U2550B_U0-1\Title_U01_psh.dgn

UTILITIES BY OTHERS

NOTE:
ALL PROPOSED UTILITY WORK
SHOWN ON THIS SHEET WILL
BE DONE BY OTHERS

STA. 12+80.00 -L- BEGIN TIP PROJECT U-2550B

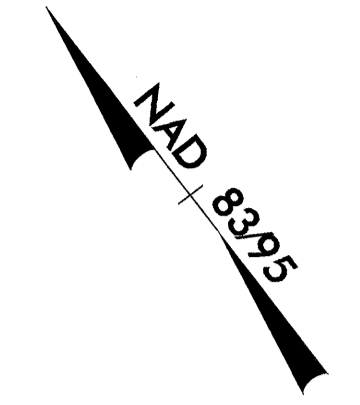

10

15

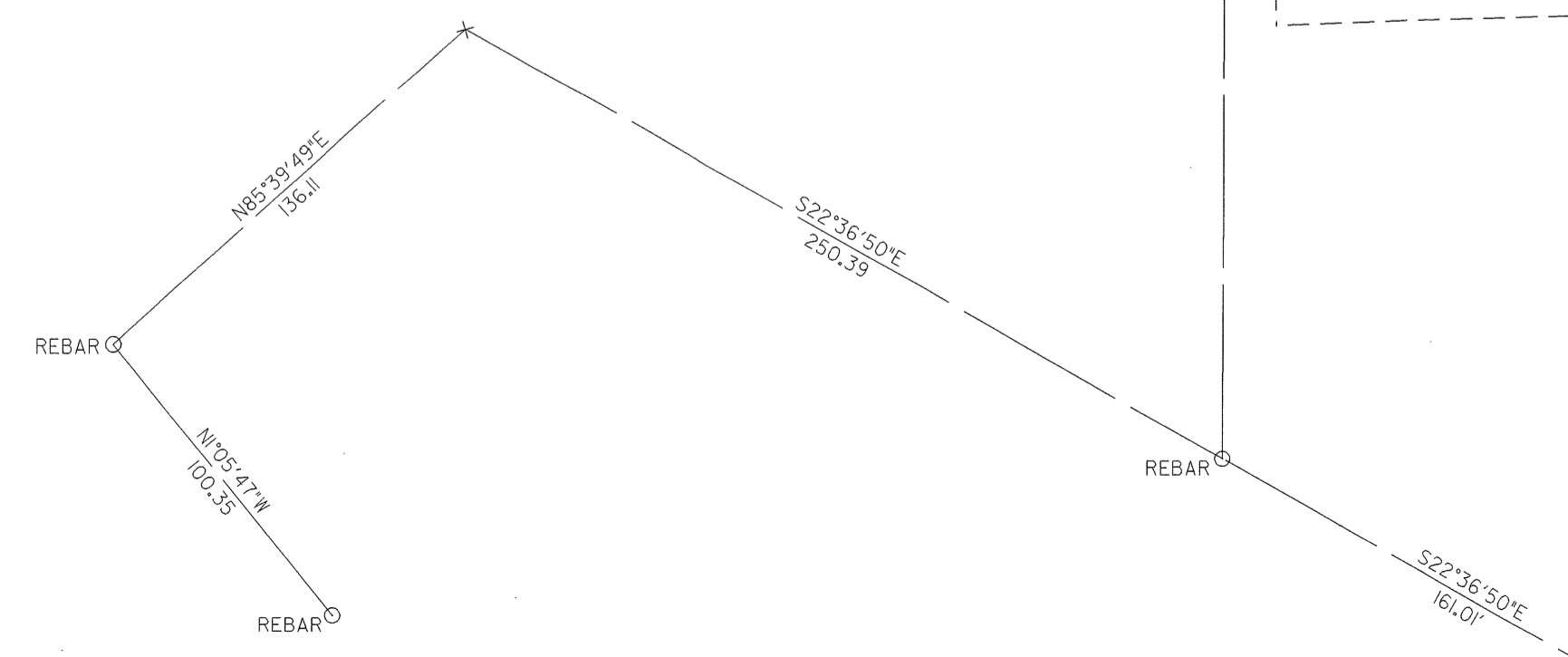
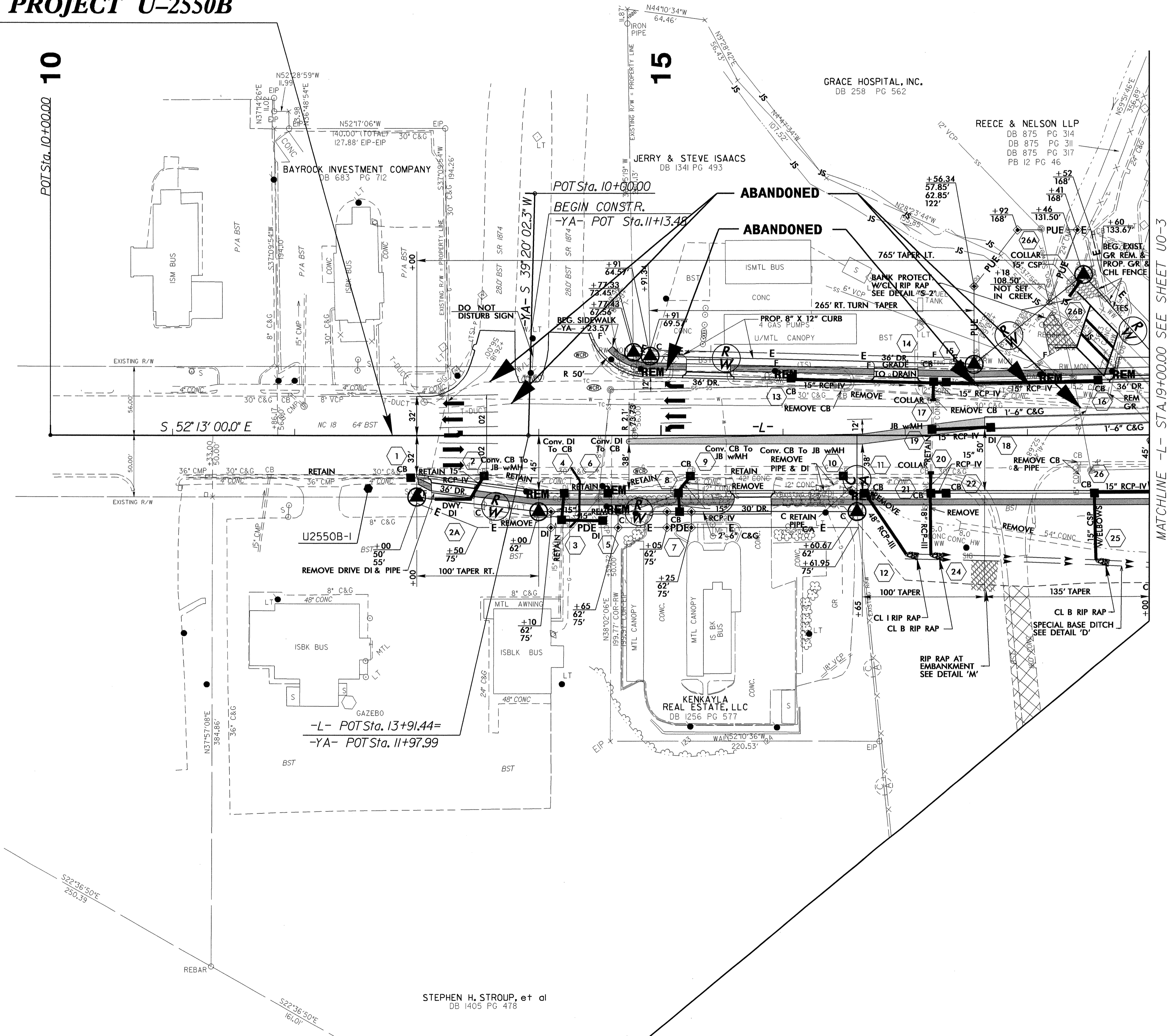

STEPHEN H. STROUP, et al
DB 1405 PG 478

MATCHLINE -L- STA. 19+00.00 SEE SHEET U0-3

5/14/99

R:\U011\21-MAR-2011\0643
11:53:11 AM\U2550B.U0-2.PSH.dgn

UTILITIES BY OTHERS

NOTE:
ALL PROPOSED UTILITY WORK
SHOWN ON THIS SHEET WILL
BE DONE BY OTHERS

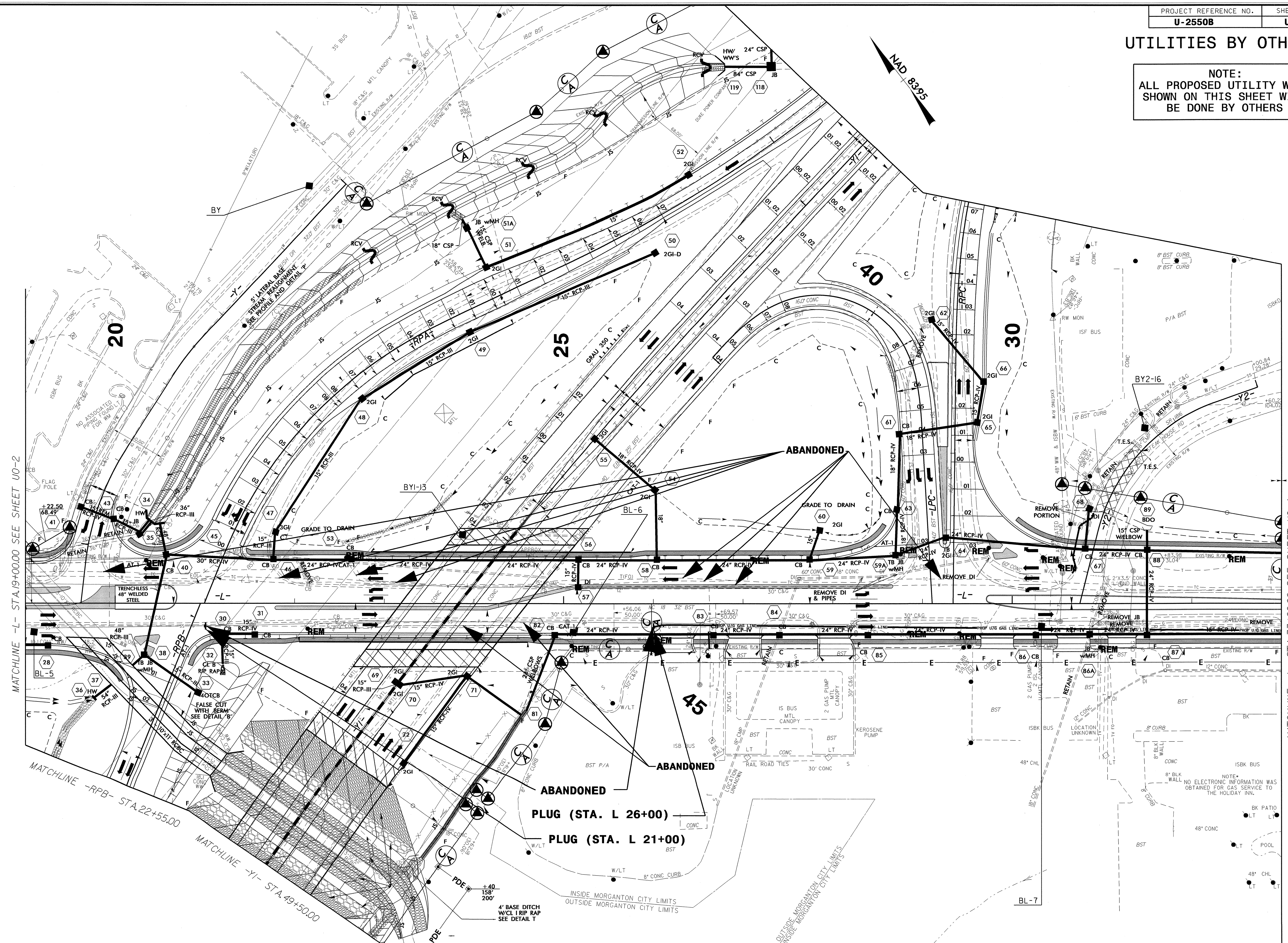

MATCHLINE -L- STA.19+00.00 SEE SHEET UO-2

MATCHLINE -RPB- STA.22+55.00

MATCHLINE -YI- STA.49+50.00

MATCHLINE -L- STA.33+00.00 SEE SHEET UO-4

ABANDONED
PLUG (STA. L 26+00)
PLUG (STA. L 21+00)

4' BASE DITCH
W/C 1' RIP RAP
SEE DETAIL T

INSIDE MORGANTON CITY LIMITS
OUTSIDE MORGANTON CITY LIMITS

OUTSIDE MORGANTON CITY LIMITS
INSIDE MORGANTON CITY LIMITS

5/14/99

R:\U\11-21-MAR-2010\06\14
11-21-MAR-2010\06\14\U2550B.U1_5_U03.PSH.dgn

NOTE:
NO ELECTRONIC INFORMATION WAS
OBTAINED FOR GAS SERVICE TO
THE HOLIDAY INN.

