

STATE OF NORTH CAROLINA  
DEPARTMENT OF TRANSPORTATION

PAVEMENT MARKING PLAN  
WAKE COUNTY

LOCATION: US 401 ROLESVILLE BYPASS FROM SR 2225,  
LOUISBURY ROAD TO NC 96, ZEBULON

TIP NO. R-2814B	SHEET NO. PMP-1
APPROVED: _____	
DATE: _____	
SEAL	

T.I.P.: R-2814B

CONTRACT: C202583

GENERAL NOTES

THE FOLLOWING GENERAL NOTES APPLY AT ALL TIMES FOR THE DURATION OF THE CONSTRUCTION PROJECT, EXCEPT WHEN OTHERWISE NOTED IN THE PLAN, OR DIRECTED BY THE ENGINEER.

A) INSTALL PAVEMENT MARKINGS AND PAVEMENT MARKERS ON THE FINAL SURFACE AS FOLLOWS:

ROAD NAME	MARKING	MARKER
US 401 LOUISBURG ROAD AND -Y- LINES	THERMOPLASTIC	RAISED

B) TIE PROPOSED PAVEMENT MARKING LINES TO EXISTING PAVEMENT MARKING LINES.

C) REMOVE/REPLACE ANY CONFLICTING/DAMAGED PAVEMENT MARKINGS AND MARKERS.

D) STOPBAR LOCATION AT NON-SIGNALIZED INTERSECTIONS MAY BE ADJUSTED AS DIRECTED BY THE ENGINEER.

E) MARKERS ARE TO PLACED ACCORDING TO THE ROADWAY STANDARD DRAWINGS.

ROADWAY STANDARD DRAWING

THE FOLLOWING ROADWAY STANDARDS AS APPEAR IN "ROADWAY STANDARD DRAWINGS" - PROJECT SERVICES UNIT - N.C. DEPARTMENT OF TRANSPORTATION - RALEIGH, N.C., DATED JULY 2006 ARE APPLICABLE TO THIS PROJECT AND BY REFERENCE HEREBY ARE CONSIDERED A PART OF THESE PLANS:

STD. NO.	TITLE
1205.01	PAVEMENT MARKINGS - LINE TYPES AND OFFSETS
1205.02	PAVEMENT MARKINGS - 2 LANE AND MULTILANE ROADWAYS
1205.04	PAVEMENT MARKINGS - INTERSECTIONS
1205.05	PAVEMENT MARKINGS - TURN LANES
1205.06	PAVEMENT MARKINGS - THRU LANE DROPS
1205.08	PAVEMENT MARKINGS - SYMBOL AND WORD MESSAGES
1205.09	PAVEMENT MARKINGS - PAINTED ISLANDS
1250.01	PAVEMENT MARKER SPACING
1251.01	RAISED PAVEMENT MARKERS - TEMPORARY AND PERMANENT

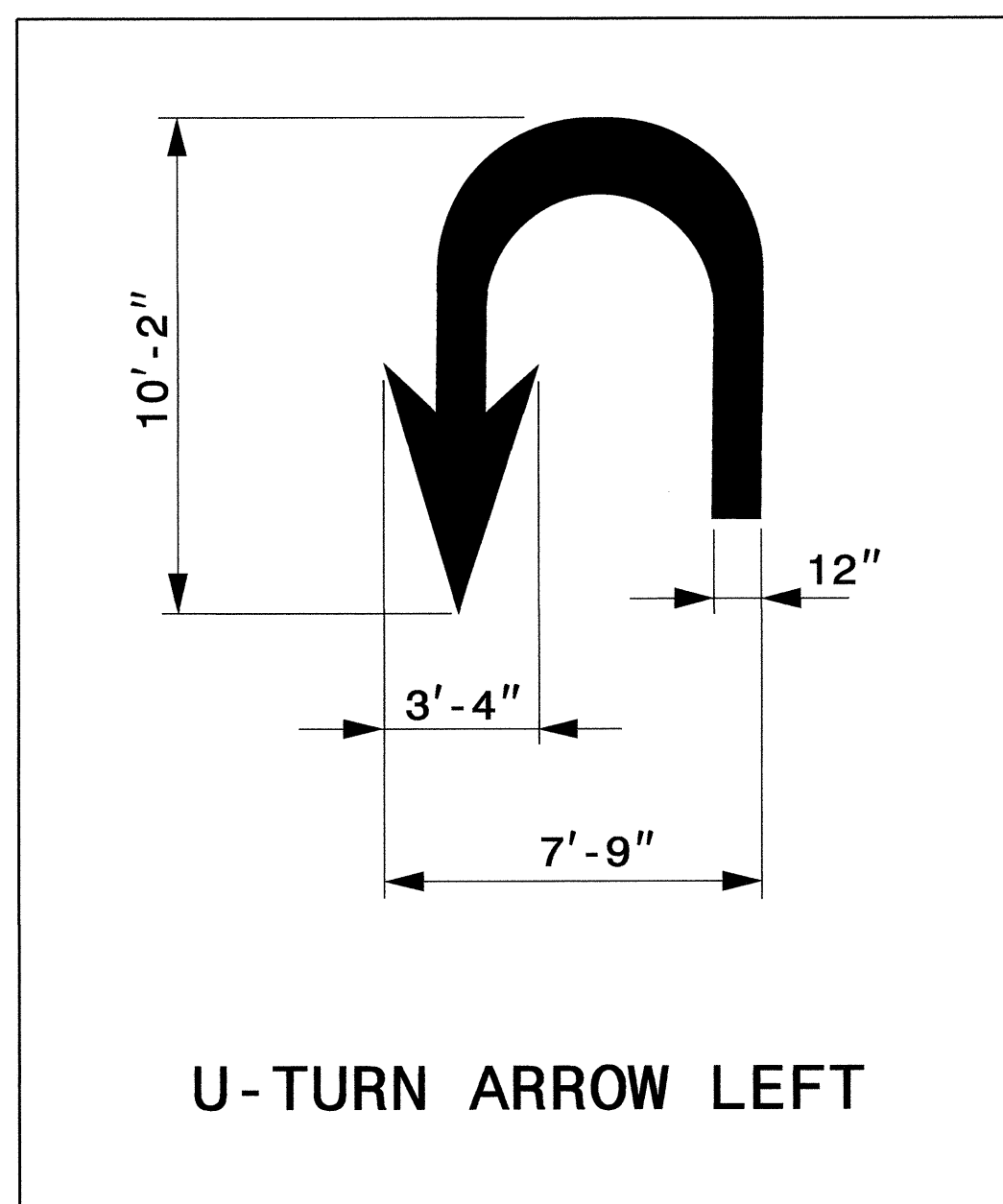

PAVEMENT MARKING SCHEDULE

SYMBOL	DESCRIPTION
THERMOPLASTIC(24", 120 MILS)	
T2	WHITE STOPBAR
THERMOPLASTIC(4", 120 MILS)	
T11	2 FT. - 8 FT./SP YELLOW MINISKIP
T8	2 FT. - 8 FT./SP WHITE MINISKIP
TC	10 FT. WHITE SKIP
TD	2 FT. - 13 FT./SP WHITE MINISKIP
TE	WHITE SOLID LANE LINE
TI	YELLOW DOUBLE CENTER
THERMOPLASTIC(4", 90 MILS)	
TA	WHITE EDGELINE
TB	YELLOW EDGELINE
THERMOPLASTIC(8", 90 MILS)	
TP	WHITE GORELINE
TQ	WHITE DIAGONAL
THERMOPLASTICPAVEMENT MARKING CHARACTER (120 MILS)	
UI	ALPHANUMERIC CHAR.
THERMOPLASTICPAVEMENT MARKING SYMBOLS (90 MILS)	
UA	LEFT TURN ARROW
UB	RIGHT TURN ARROW
UC	STRAIGHT ARROW
UN	24" YIELD LINE TRIANGLE
UT	U-TURN ARROW
MARKERS	
PERMANENT RAISED PAVEMENT MARKERS	
MA	YELLOW & YELLOW
MB	CRYSTAL & RED

PLAN PREPARED BY: N.C.D.O.T. SIGNING AND DELINEATION UNIT

SUSAN B. KUNZ	SIGNING & DELINEATION REGIONAL ENGINEER
STACEY JOHNS	SIGNING & DELINEATION DESIGN ENGINEER

INDEX

SHEET NO.	DESCRIPTION
PMP-1	PAVEMENT MARKING PLAN TITLE SHEET AND PAVEMENT MARKING SCHEDULE
PMP-2-PMP-9	PAVEMENT MARKING DETAIL

03-NOV-2010 14:29 R2814B-Traffic\Signing\CADD\PMP\Title.dgn  
St Johns - 11/23/10

TIP NO. R-2814B	SHEET NO. PMP-2
APPROVED: _____	
DATE: _____	
SEAL	

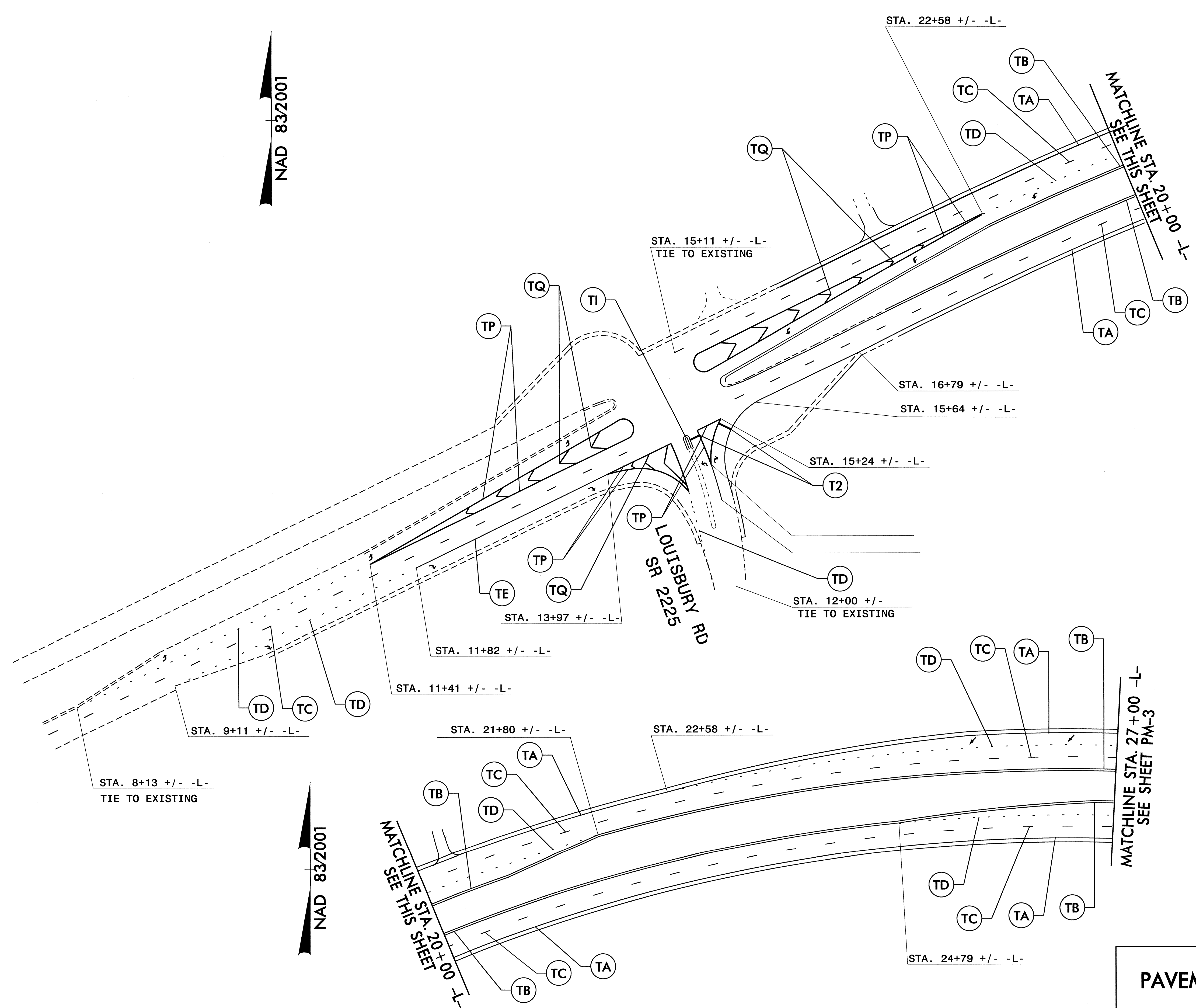

MATCHLINE STA. 27+00 -L-  
SEE SHEET PM-3

MATCHLINE STA. 20+00 -L-  
SEE THIS SHEET

LOUTSBURY RD  
SR 2225

**PAVEMENT MARKING DETAIL**

03-1001-2010 1423  
 N:\TIP\Projects\2814b\Traffic\Signing\CADD\PM-2\2814b.pmp00.dgn  
 3/10/10 11:27:57

TIP NO. R-2814B	SHEET NO. PMP-3
APPROVED: _____	
DATE: _____	
SEAL	

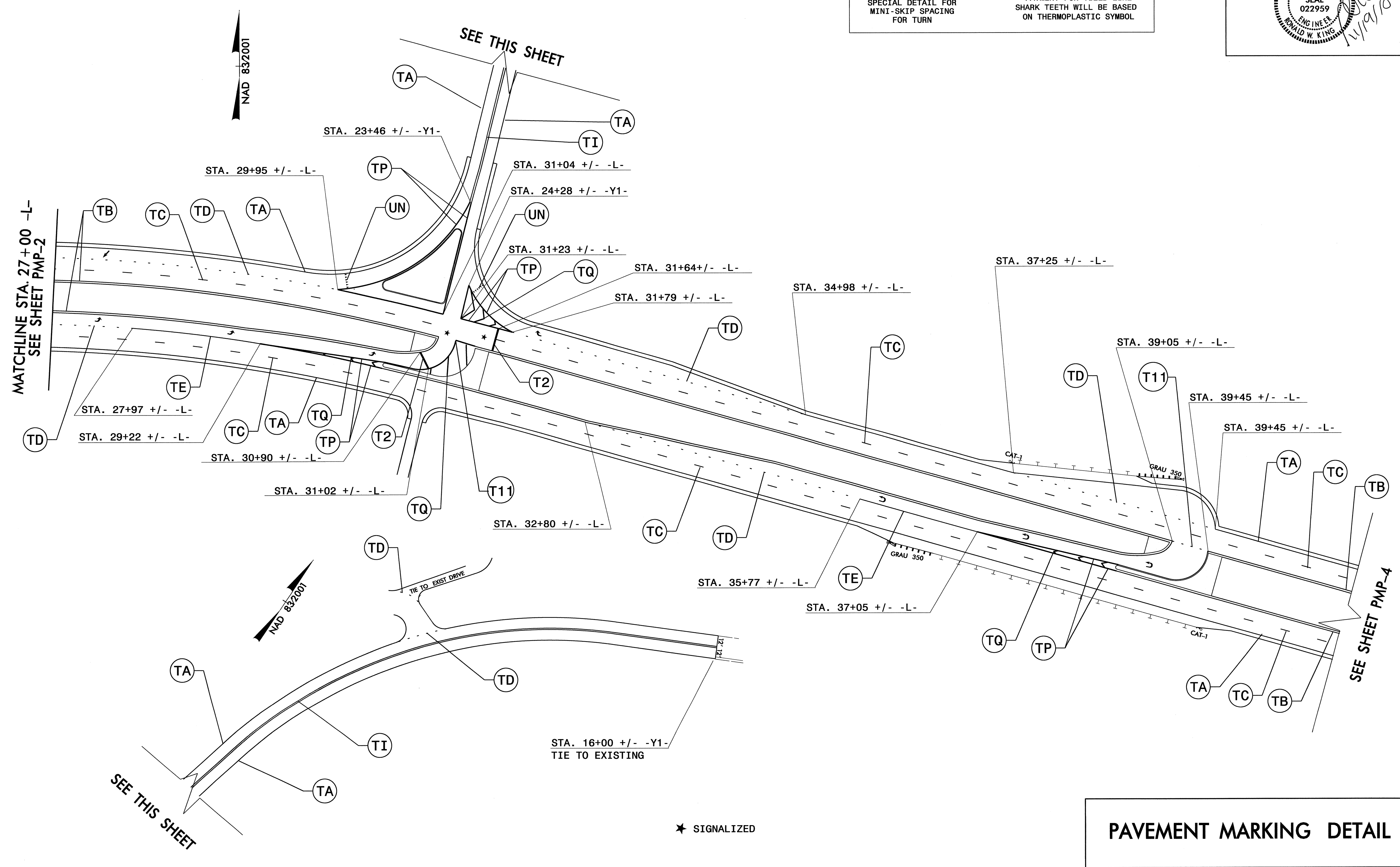
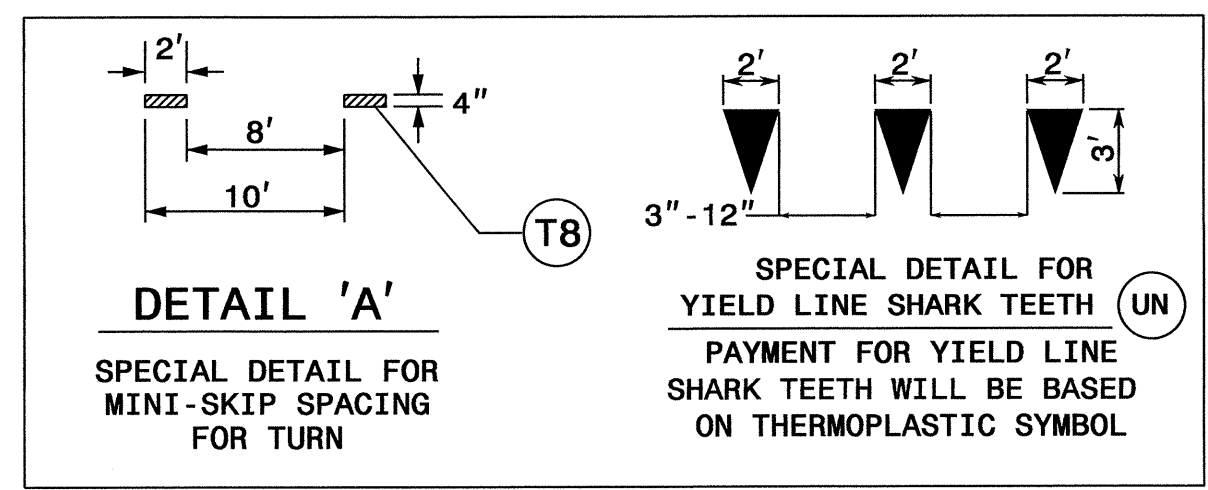

★ SIGNALIZED

**PAVEMENT MARKING DETAIL**

03-NOV-2010 15:37  
 N:\pmp\2814b\Traffic\Signing\CADD\PMP-3-2814b\_pmp01.dgn  
 s.johns  
 11/19/10



TIP NO. R-2814B	SHEET NO. PMP-4
APPROVED: _____	
DATE: _____	
SEAL	

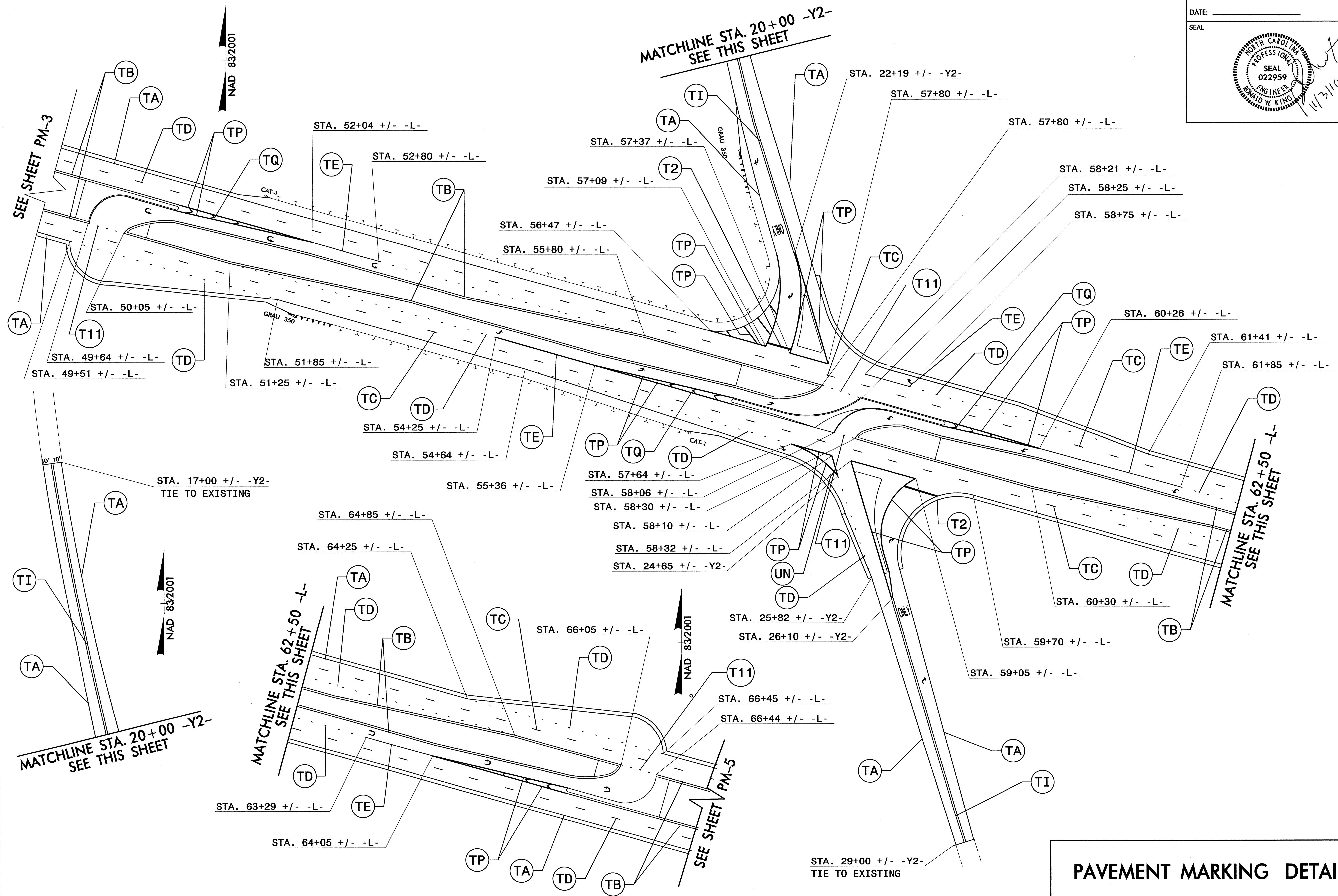

**PAVEMENT MARKING DETAIL**

02-10-2010 14:35 P2814B\Traffic\Signing\CADD\PMP-4-2814b\_pmp02.dgn  
 sjohns 11/3/10 11:24:55

TIP NO. R-2814B	SHEET NO. PMP-5
APPROVED: _____	
DATE: _____	
SEAL	

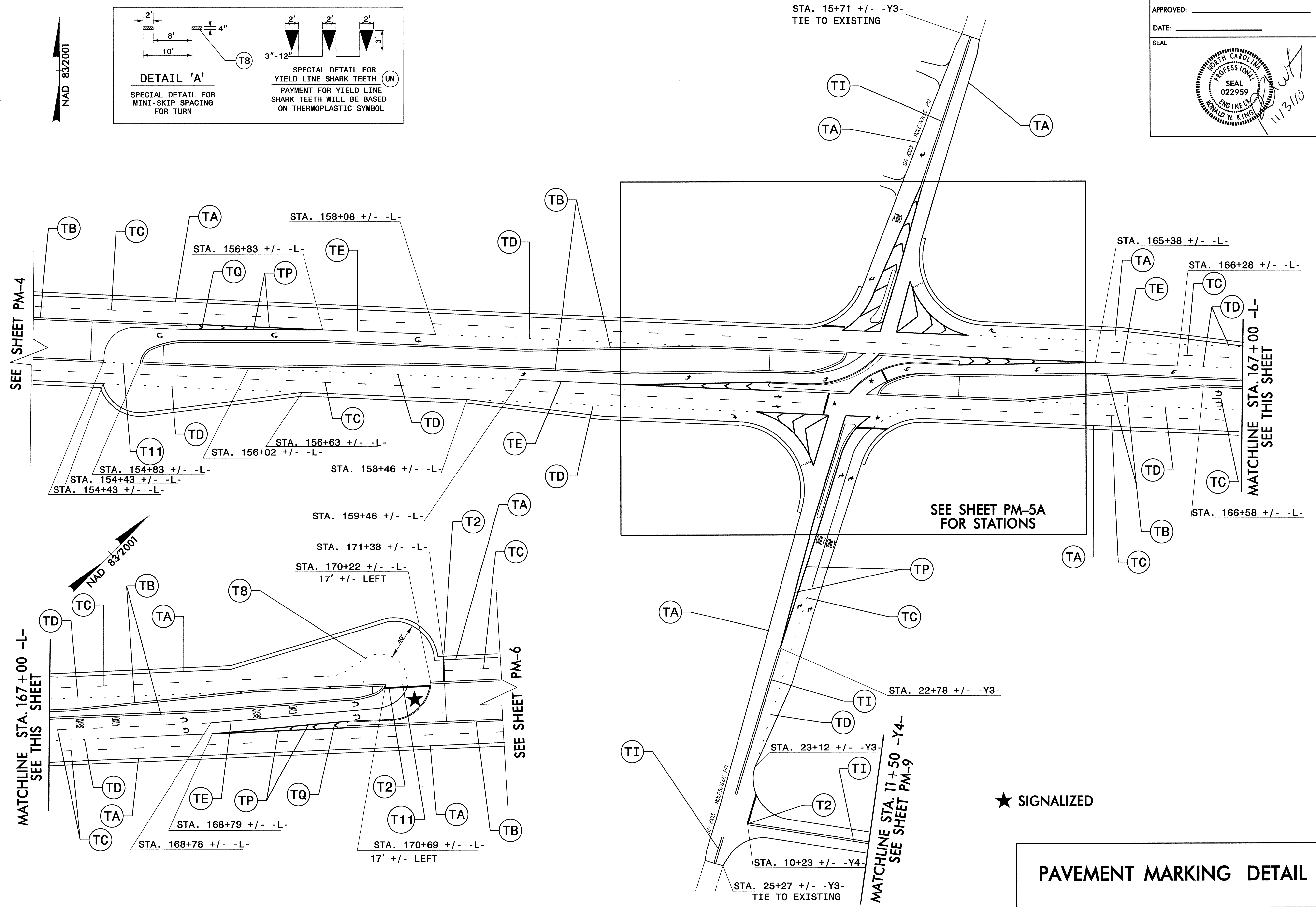
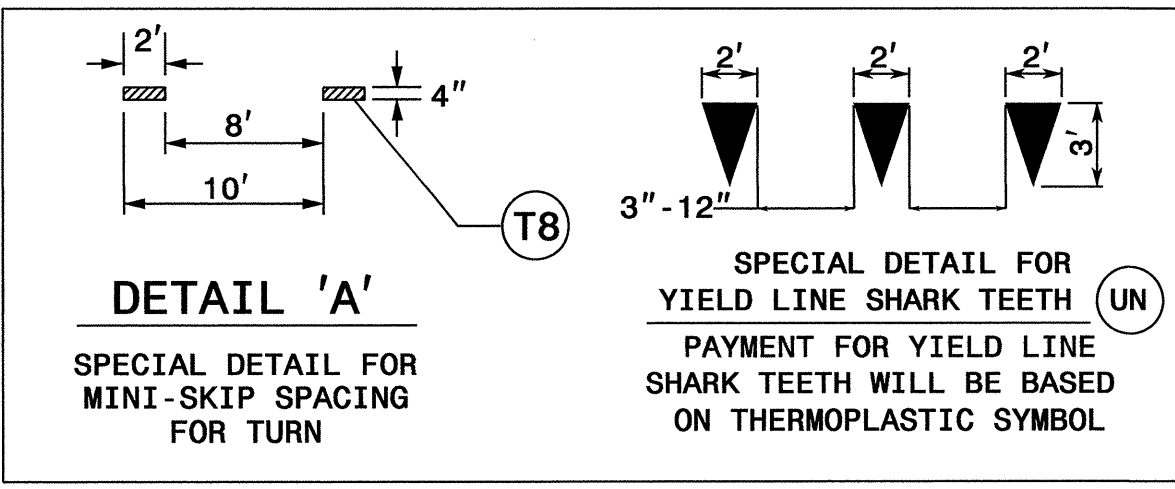

★ SIGNALIZED

**PAVEMENT MARKING DETAIL**

03-Nov-2010 14:37  
 Q:\pmp\2814b\Traffic\Signing\CADD\PM-5-2814b.pmp03.dgn  
 s.johns - A1 - 11/2/10

TIP NO. R-2814B	SHEET NO. PMP-5A
APPROVED: _____	
DATE: _____	
SEAL	

NAD 83/2001

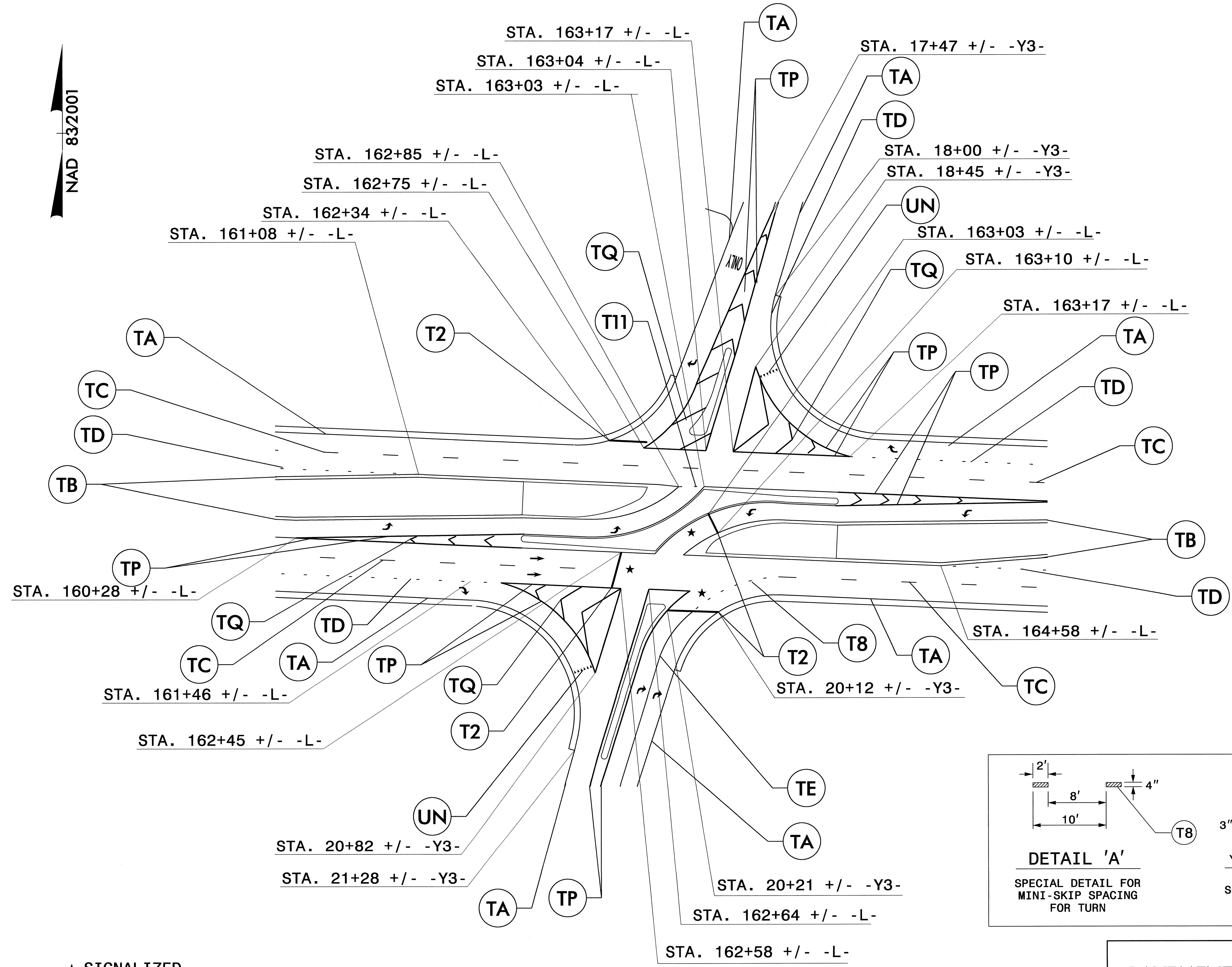

★ SIGNALIZED

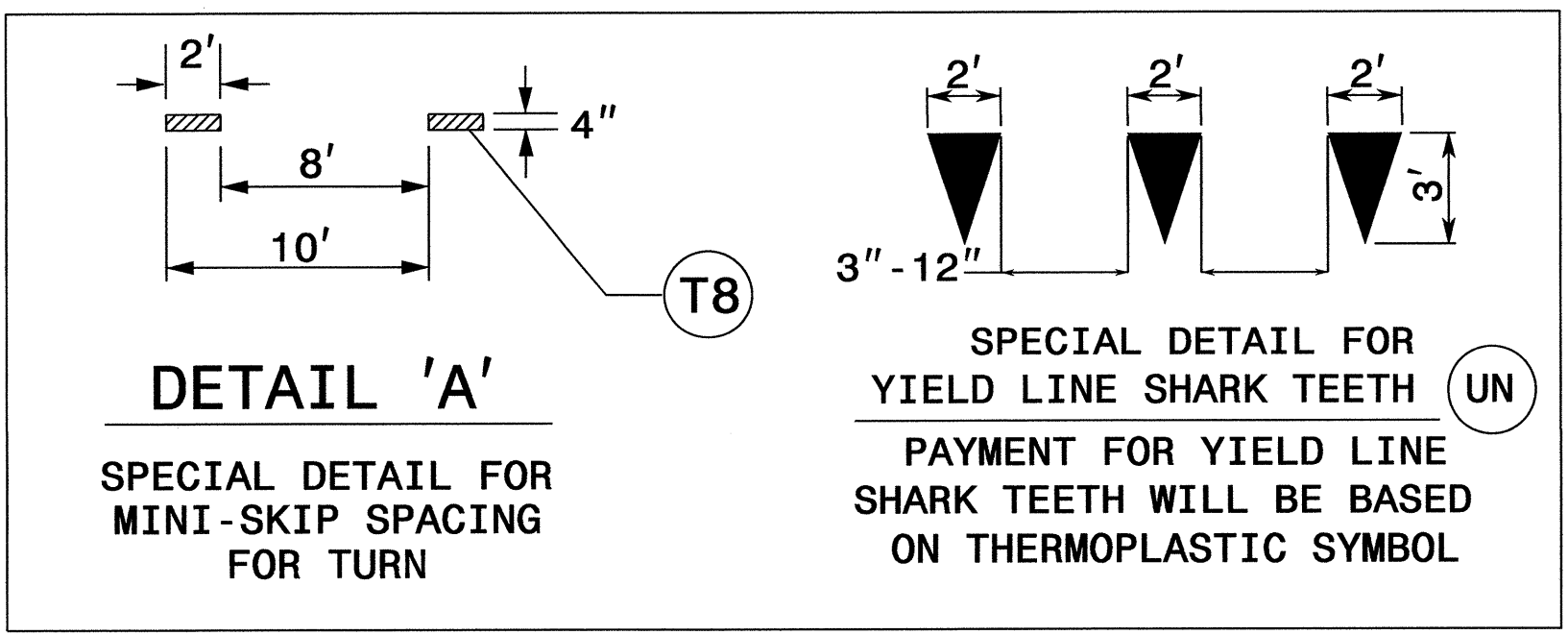

**PAVEMENT MARKING DETAIL**

03-NOV-2010 15:04 162814b\Traffic\Signing\CADD\PM\2814b\_pmp05a.dgn sjohns



TIP NO. R-2814B	SHEET NO. PMP-6
APPROVED: _____	
DATE: _____	
SEAL	

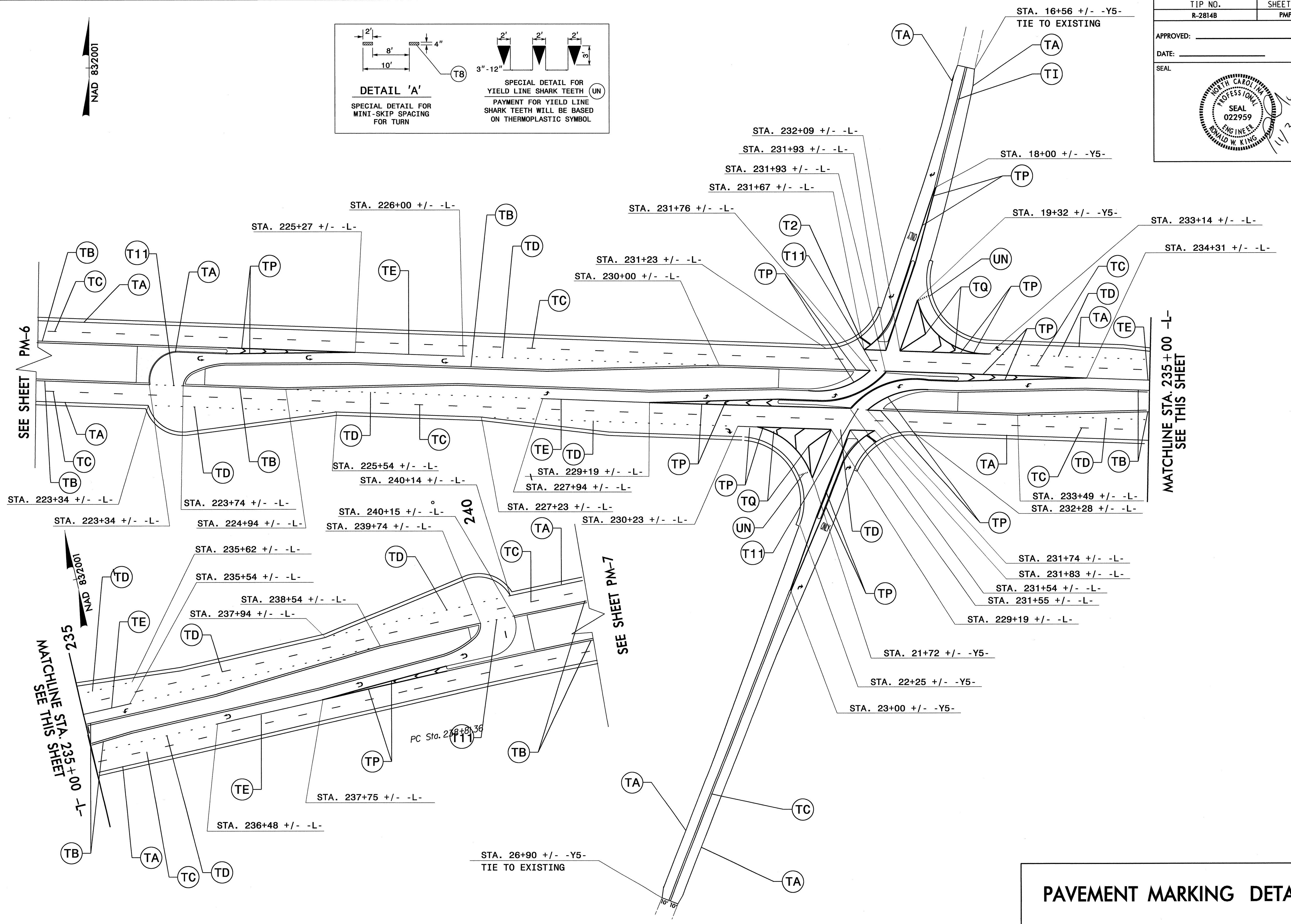
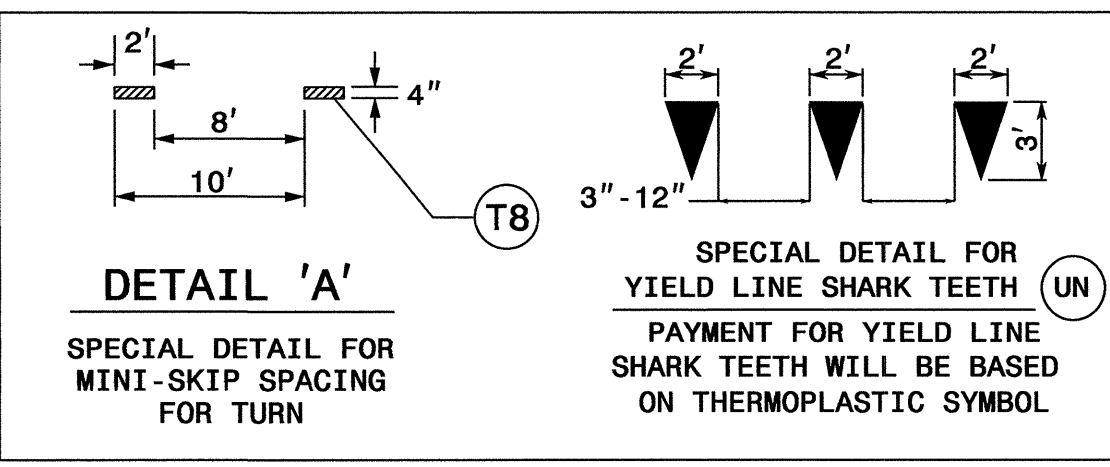

**PAVEMENT MARKING DETAIL**

03-NOV-2010 15:05  
 N:\TIP\Projects\2814B\Traffic\Signing\CADD\PM-6\2814b\_pmp04.dgn  
 s.johns - H1 12/24/10

TIP NO. R-2814B	SHEET NO. PMP-7
APPROVED: _____	
DATE: _____	
SEAL	

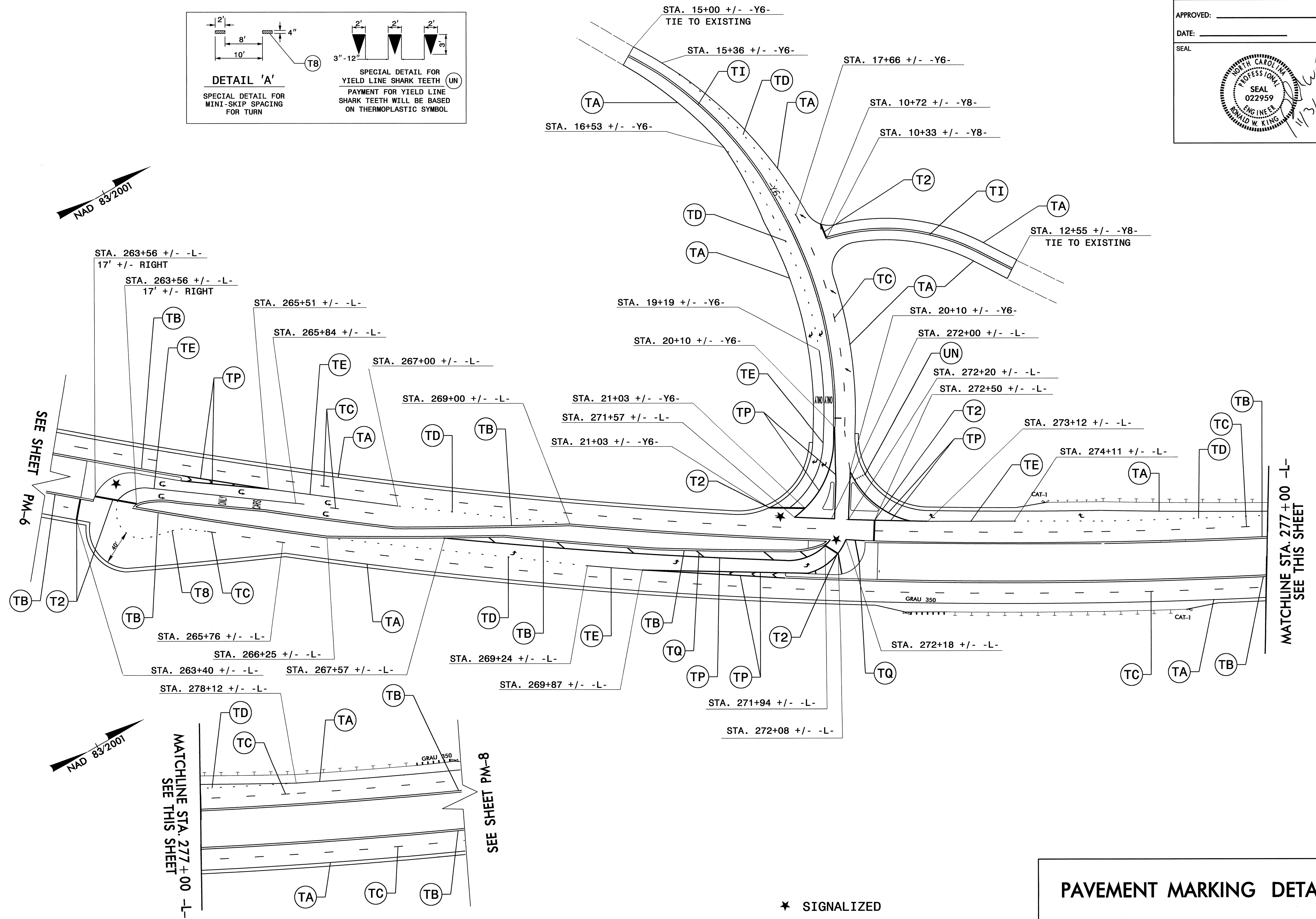
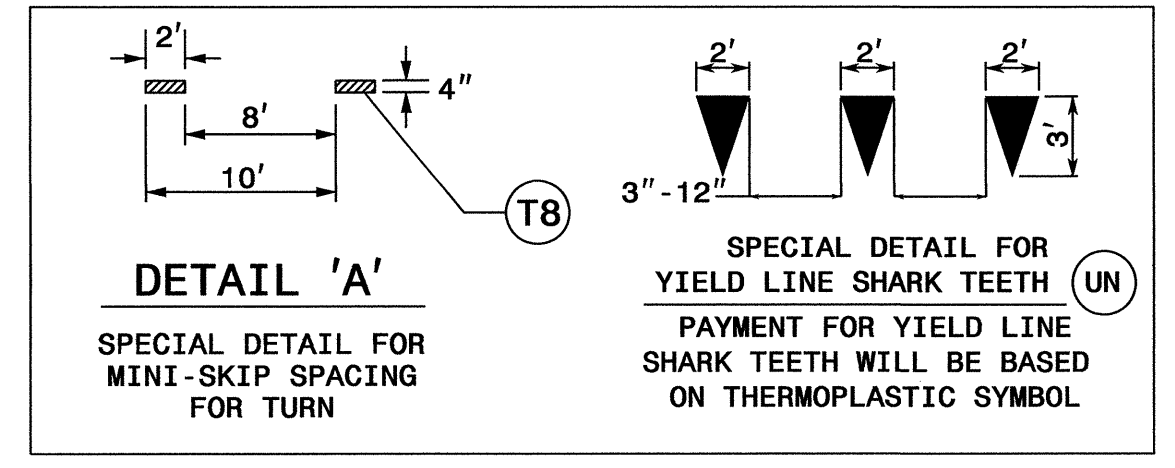

**PAVEMENT MARKING DETAIL**

02-10-2010 15:00 \\p02814b\Trff\c:\Signmg\CADD\PM-7\2814b\_pmp05.dgn  
 sjohns 11/3/10 11:24:55

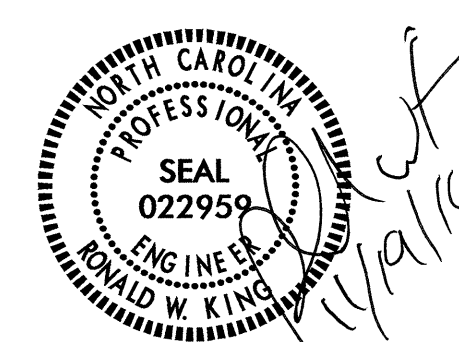

TIP NO. R-2814B	SHEET NO. PMP-8
APPROVED: _____	
DATE: _____	
SEAL	
	

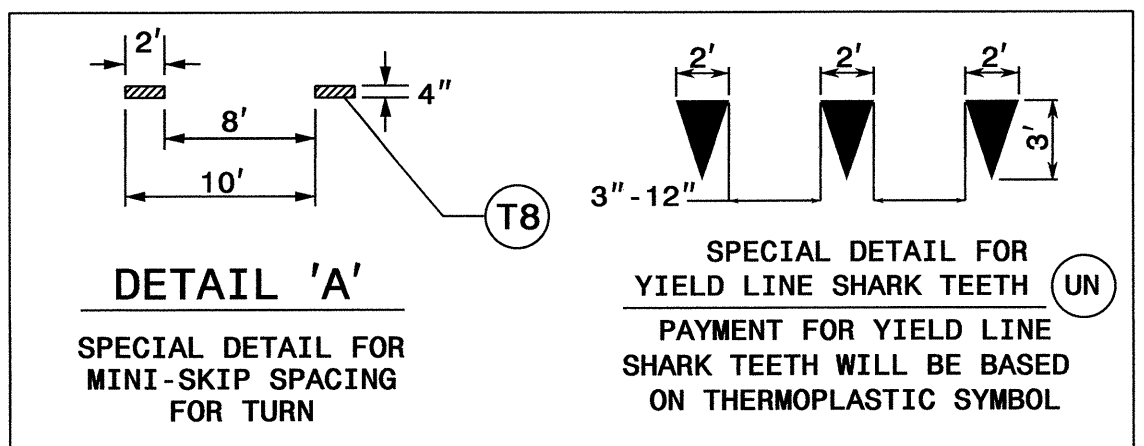
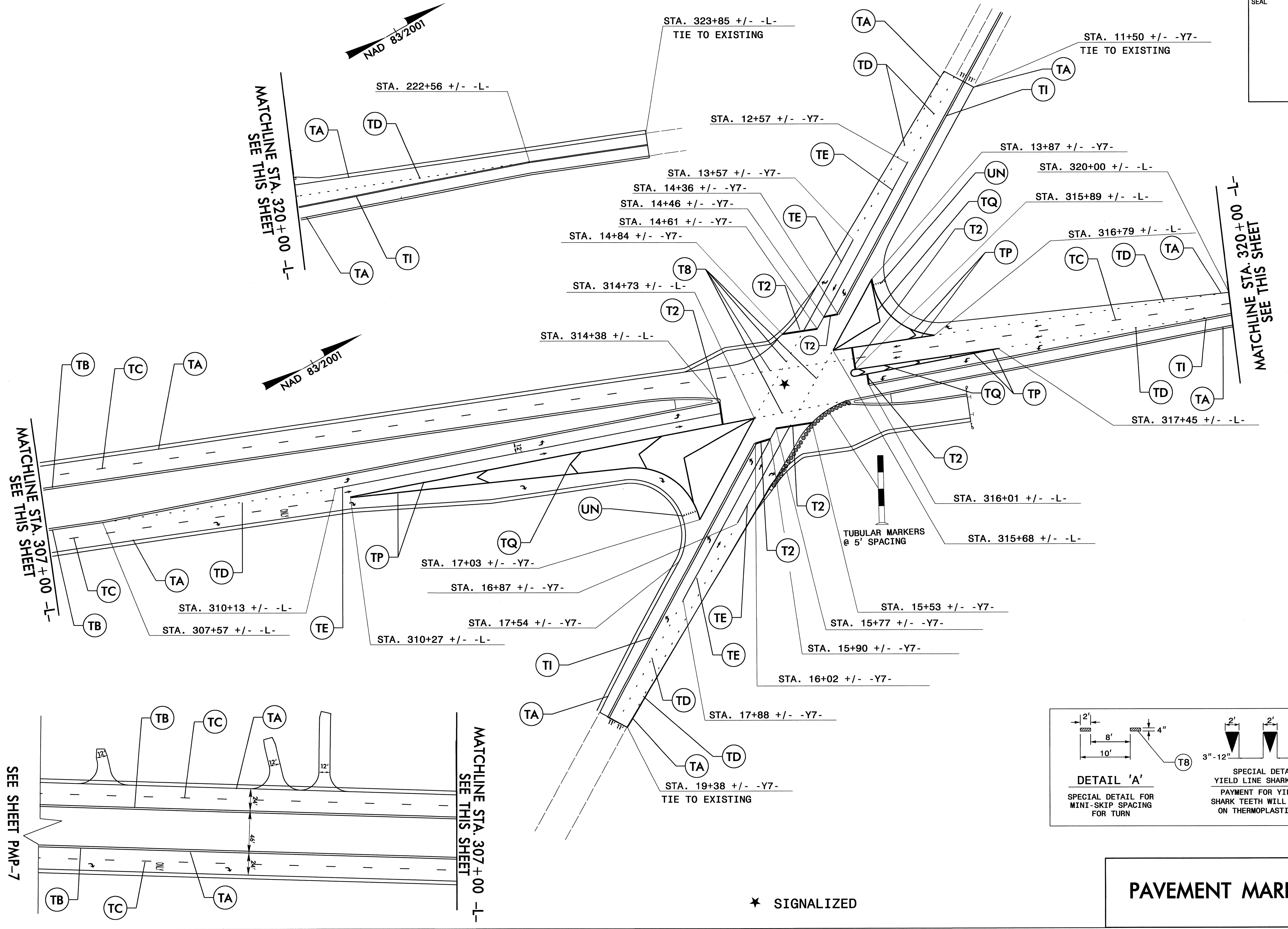

**PAVEMENT MARKING DETAIL**

09/NOV/2010 15:38  
 C:\Users\johns\Documents\Projects\2814B\Traffic\Signing\CADD\PMPPMP-8-2814B.pmp06.dgn  
 s.johns

TIP NO. R-2814B	SHEET NO. PMP-9
APPROVED: _____	
DATE: _____	
SEAL	



MATCHLINE STA. 11+50 -Y4-  
SEE SHEET PM-5

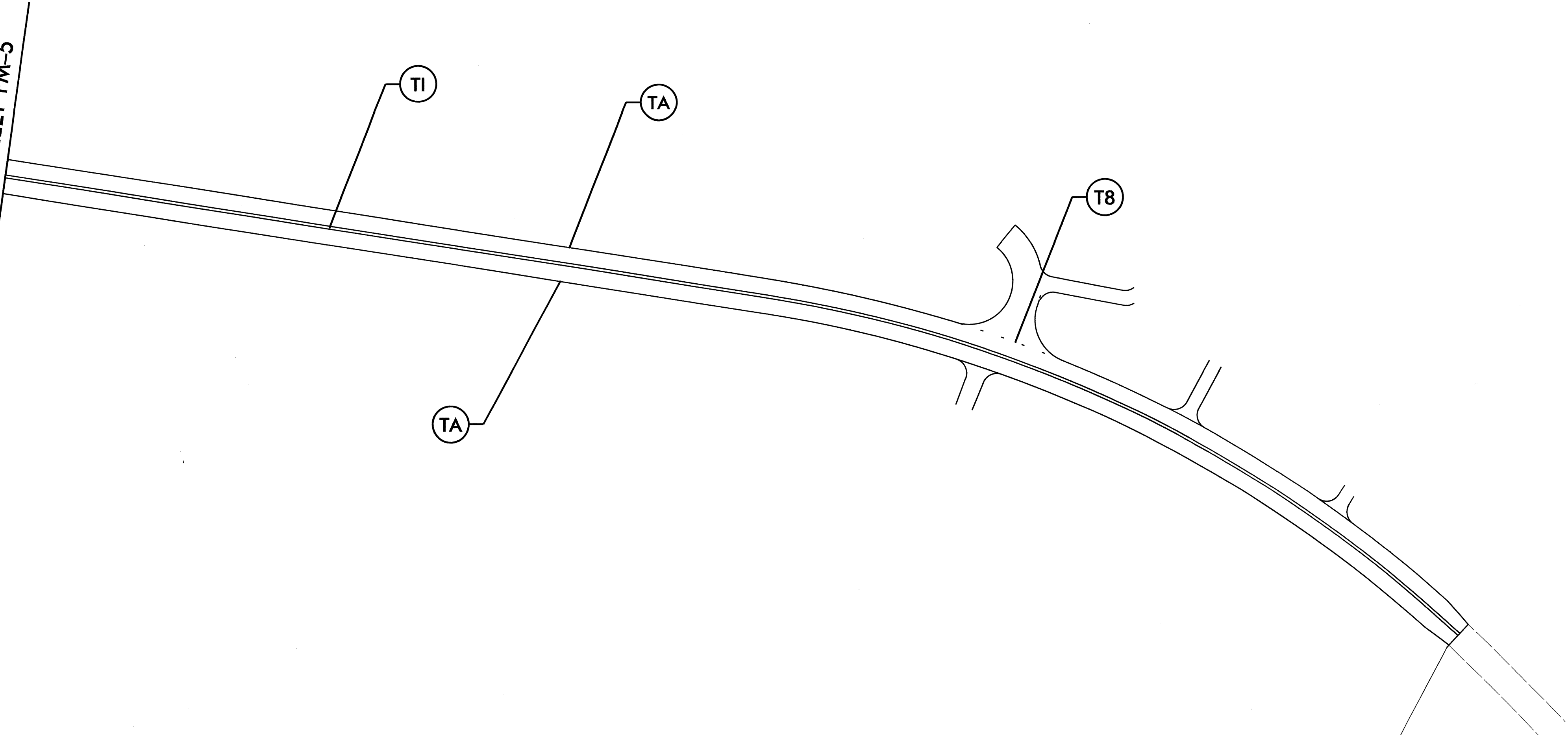

STA. 22+29 +/- -Y4-  
TIE TO EXISTING

**PAVEMENT MARKING DETAIL**

03-NOV-2010 13:53  
N:\TIP-projects\2814B\Traffic\Signing\CADD\PM-9-2814b\_pmp07.dgn  
Systems - PL - 11/3/10