

STATE OF NORTH CAROLINA
DEPARTMENT OF TRANSPORTATION

PAVEMENT MARKING PLAN
CLAY COUNTY

LOCATION: BRIDGE NO. 3 OVER BRASSTOWN CREEK ON SR 1111
(WEST ROAD)

TIP NO. B-4467	SHEET NO. PMP-1
APPROVED: <i>[Signature]</i>	
DATE: 2/10/11	
SEAL	
	

T.I.P.: B-4467

CONTRACT: C202430

ROADWAY STANDARD DRAWING

THE FOLLOWING ROADWAY STANDARDS AS APPEAR IN "ROADWAY STANDARD DRAWINGS" - PROJECT SERVICES UNIT - N.C. DEPARTMENT OF TRANSPORTATION - RALEIGH, N.C., DATED JULY 2006 ARE APPLICABLE TO THIS PROJECT AND BY REFERENCE HEREBY ARE CONSIDERED A PART OF THESE PLANS:

STD. NO.	TITLE
1205.01	PAVEMENT MARKINGS - LINE TYPES AND OFFSETS
1205.02	PAVEMENT MARKINGS - 2 LANE AND MULTILANE ROADWAYS
1205.12	PAVEMENT MARKINGS - BRIDGES
1261.01	GUARDRAIL AND BARRIER DELINEATOR SPACING
1261.02	GUARDRAIL AND BARRIER DELINEATOR TYPES
1262.01	GUARDRAIL END DELINEATION

GENERAL NOTES

THE FOLLOWING GENERAL NOTES APPLY AT ALL TIMES FOR THE DURATION OF THE CONSTRUCTION PROJECT, EXCEPT WHEN OTHERWISE NOTED IN THE PLAN, OR DIRECTED BY THE ENGINEER.

- A) INSTALL PAVEMENT MARKINGS AND PAVEMENT MARKERS ON THE FINAL SURFACE AS FOLLOWS:

ROAD NAME	MARKING	MARKER
SR 1111 (WEST ROAD)	PAINT	
- B) STATE FORCES WILL INSTALL PAVEMENT MARKINGS AND PAVEMENT MARKERS ON THE FINAL SURFACE AS FOLLOWS:

ROAD NAME	MARKING	MARKER
- C) PLACE TWO APPLICATIONS OF PAINT PAVEMENT MARKINGS ON THE FINAL WEARING SURFACE. PLACE THE SECOND APPLICATION OF PAINT UPON SUFFICIENT DRYING TIME OF THE FIRST.
- D) TIE PROPOSED PAVEMENT MARKING LINES TO EXISTING PAVEMENT MARKING LINES.
- E) REMOVE/REPLACE ANY CONFLICTING/DAMAGED PAVEMENT MARKINGS AND MARKERS.
- F) PASSING ZONES WILL BE DETERMINED IN THE FIELD AND MUST BE APPROVED BY THE ENGINEER.
- G) STOPBAR LOCATION AT NON-SIGNALIZED INTERSECTIONS MAY BE ADJUSTED AS DIRECTED BY THE ENGINEER.
- H) REMOVE ALL RESIDUE AND SURFACE LAITANCE BY ACCEPTABLE METHODS ON THE BRIDGE DECK(S) PRIOR TO PLACING (PAVEMENT MARKING MATERIAL HERE) PAVEMENT MARKING.

INDEX

SHEET NO.	DESCRIPTION
PMP-1	PAVEMENT MARKING PLAN TITLE
PMP-2	PAVEMENT MARKING DETAIL

PLAN PREPARED BY: N.C.D.O.T. SIGNING AND DELINEATION UNIT

Ayman I Alqudwah, P.E. SIGNING & DELINEATION REGIONAL ENGINEER

WALTER JOHNSON SIGNING & DELINEATION PROJECT DESIGN ENGINEER/TECHNICIAN

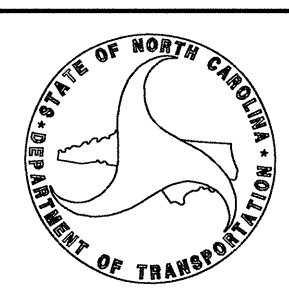

TIP NO. B-4467	SHEET NO. PMP-2
APPROVED: <i>[Signature]</i>	
DATE: 2/10/11	
SEAL	
	

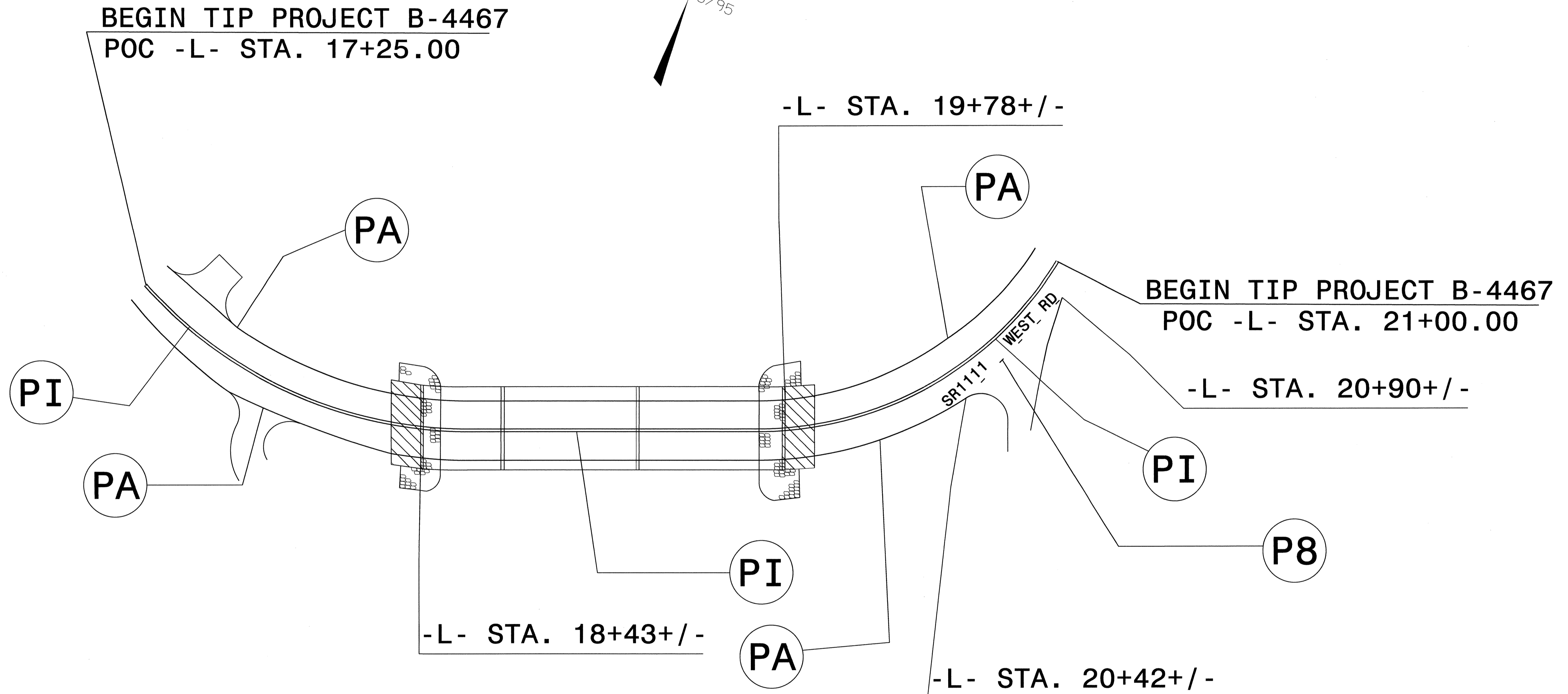

PAVEMENT MARKING SCHEDULE	
SYMBOL	DESCRIPTION
PA	WHITE EDGELINE (4")
P8	WHITE MINISKIP (4")
PI	YELLOW DOUBLE CENTER(4")

PAVEMENT MARKING DETAIL

10-FEB-2011 08:56
 P:\TIP\Projects-B\B4467\Traffic\Signing\CADD\PM\B-4467_Sgn_BPMP_Basemap.dgn
 Walter Johnson AT 1/24/11