

T.I.P.: R-2233AB

**STATE OF NORTH CAROLINA  
DEPARTMENT OF TRANSPORTATION**

**PAVEMENT MARKING PLAN**

**RUTHERFORD COUNTY**

LOCATION: US 221 FROM JUST NORTH OF SR 2125  
TO JUST NORTH OF SR 2171

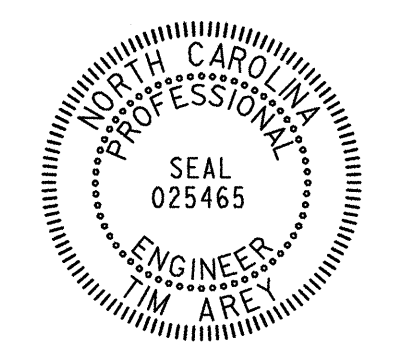
TIP NO. R-2233AB	SHEET NO. PMP-1
APPROVED: <i>Tim Arey</i>	
DATE: 6/29/10	
SEAL 	

**ROADWAY STANDARD DRAWING**

THE FOLLOWING ROADWAY STANDARDS AS APPEAR IN "ROADWAY STANDARD DRAWINGS" - PROJECT SERVICES UNIT - N.C. DEPARTMENT OF TRANSPORTATION - RALEIGH, N.C., DATED JULY 2006 ARE APPLICABLE TO THIS PROJECT AND BY REFERENCE HEREBY ARE CONSIDERED A PART OF THESE PLANS:

STD. NO.	TITLE
1205.01	PAVEMENT MARKINGS - LINE TYPES AND OFFSETS
1205.02	PAVEMENT MARKINGS - 2 LANE AND MULTILANE ROADWAYS
1205.03	PAVEMENT MARKINGS - INTERCHANGES
1205.04	PAVEMENT MARKINGS - INTERSECTIONS
1205.05	PAVEMENT MARKINGS - TURN LANES
1205.06	PAVEMENT MARKINGS - THRU LANE DROPS
1205.08	PAVEMENT MARKINGS - SYMBOL AND WORD MESSAGES
1205.09	PAVEMENT MARKINGS - PAINTED ISLANDS
1205.10	PAVEMENT MARKINGS - SCHOOL AREAS
1205.12	PAVEMENT MARKINGS - BRIDGES
1250.01	PAVEMENT MARKER SPACING
1253.01	SNOWPLOWABLE RAISED PAVEMENT MARKERS
1261.01	GUARDRAIL AND BARRIER DELINEATOR SPACING
1261.02	GUARDRAIL AND BARRIER DELINEATOR TYPES
1262.01	GUARDRAIL END DELINEATION
1264.01	OBJECT MARKERS
1264.02	PLACEMENT OF OBJECT MARKERS
1267.01	FLEXIBLE DELINEATOR INSTALLATION
1267.02	FLEXIBLE DELINEATOR SPACING
1267.03	FLEXIBLE DELINEATOR - INTERCHANGES

**INDEX**

SHEET NO.	DESCRIPTION
PMP-1	PAVEMENT MARKING PLAN COVER SHEET
PMP-2	PAVEMENT MARKING SCHEDULE
PMP-3-27	PAVEMENT MARKING DETAIL

**GENERAL NOTES**

THE FOLLOWING GENERAL NOTES APPLY AT ALL TIMES FOR THE DURATION OF THE CONSTRUCTION PROJECT, EXCEPT WHEN OTHERWISE NOTED IN THE PLAN, OR DIRECTED BY THE ENGINEER.

- A) INSTALL PAVEMENT MARKINGS AND PAVEMENT MARKERS ON THE FINAL SURFACE AS FOLLOWS:

ROAD NAME	MARKING	MARKER
ALL	THERMOPLASTIC	SNOWPLOWABLE RAISED
-L- BRIDGES	COLD APPLIED PLASTIC-TYPE 2	
- B) TIE PROPOSED PAVEMENT MARKING LINES TO EXISTING PAVEMENT MARKING LINES.
- C) REMOVE/REPLACE ANY CONFLICTING/DAMAGED PAVEMENT MARKINGS AND MARKERS.
- D) STOPBAR LOCATION AT NON-SIGNALIZED INTERSECTIONS MAY BE ADJUSTED AS DIRECTED BY THE ENGINEER.
- E) REMOVE ALL RESIDUE AND SURFACE LAITANCE BY ACCEPTABLE METHODS ON THE BRIDGE DECKS PRIOR TO PLACING COLD APPLIED PLASTIC PAVEMENT MARKING.
- F) SNOWPLOWABLE MARKERS ARE TO BE PLACED ACCORDING TO THE ROADWAY STANDARD DRAWINGS.

**PLAN REVIEWED BY: N.C.D.O.T. SIGNING AND DELINEATION UNIT**

CHRIS HOWARD SIGNING & DELINEATION STANDARDS ENGINEER  
MARK MANRIQUEZ SIGNING & DELINEATION PROJECT DESIGN ENGINEER

**PLAN PREPARED BY: PROGRESSIVE DESIGN GROUP, INC.**

TIM AREY, P.E. PROJECT MANAGER  
LARRY ASHLEY ENGINEER

PLAN PREPARED IN THE OFFICE OF

**PROGRESSIVE  
DESIGN GROUP, INC.**



ENGINEERS • CONSULTANTS

CHARLOTTE, NC 704.573.5005

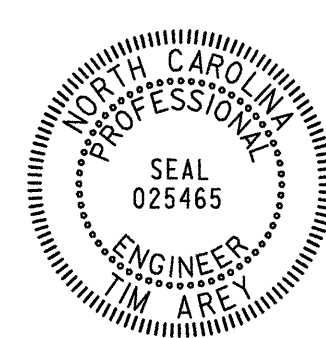
TIP NO.	SHEET NO.
R-2233AB	PMP-2
APPROVED: <i>[Signature]</i>	
DATE: 8/24/10	
SEAL	
	

SYMB	DESCRIPTION	PAY ITEM	QUANTITY	TOTAL
THERMOPLASTIC(24", 120 MILS)				
T2	WHITE STOPBAR		420 LF	
		TOTAL		420 LF
COLD APPLIED PLASTIC (4") Type 2- Permanent High Performance				
CA	WHITE EDGELINE		790 LF	
CB	YELLOW EDGELINE		490 LF	
CC	10 FT. WHITE SKIP		198 LF	
CD	2 FT. WHITE MINISKIP		33 LF	
CI	YELLOW DOUBLE CENTER		640 LF	
		TOTAL		2151 LF
THERMOPLASTIC(4", 120 MILS)				
TC	10 FT. WHITE SKIP		15700 LF	
TD	2 FT. WHITE MINISKIP		1849 LF	
TE	WHITE SOLID LANE LINE		6100 LF	
TI	YELLOW DOUBLE CENTER		13400 LF	
		TOTAL		37049 LF
THERMOPLASTIC(4", 90 MILS)				
TA	WHITE EDGELINE		85500 LF	
TB	YELLOW EDGELINE		62800 LF	
		TOTAL		148300 LF
THERMOPLASTIC(6", 120 MILS)				
TN	2 FT. YELLOW MINISKIP		146 LF	
		TOTAL		146 LF
COLD APPLIED PLASTIC (8") Type 2- Permanent High Performance				
CV	YELLOW DIAGONAL		50 LF	
		TOTAL		50 LF
THERMOPLASTIC(8", 90 MILS)				
TP	WHITE GORELINE		30600 LF	
TQ	WHITE DIAGONAL		5600 LF	
TT	YELLOW DIAGONAL		1300 LF	
		TOTAL		37500 LF
THERMOPLASTICPAVEMENT MARKING CHARACTER (120 MILS)				
UI	ALPHANUMERIC CHAR.		20 EA	
		TOTAL		20 EA
THERMOPLASTICPAVEMENT MARKING SYMBOLS (90 MILS)				
UA	LEFT TURN ARROW		61 EA	
UB	RIGHT TURN ARROW		95 EA	
UC	STRAIGHT ARROW		3 EA	
UF	COMBO. LEFT/RIGHT		3 EA	
UG	LEFT/RIGHT/STRAIGHT		6 EA	
UK	U-TURN ARROW		51 EA	
		TOTAL		219 EA
MARKERS				
SNOWPLOWABLE RAISED PAVEMENT MARKERS				
ME	YELLOW & YELLOW		305 EA	
MF	CRYSTAL & RED		1935 EA	
		TOTAL		2240 EA

TIP NO. R-2233AB	SHEET NO. PMP-3
APPROVED: <i>[Signature]</i>	
DATE: 6/29/10	
SEAL	

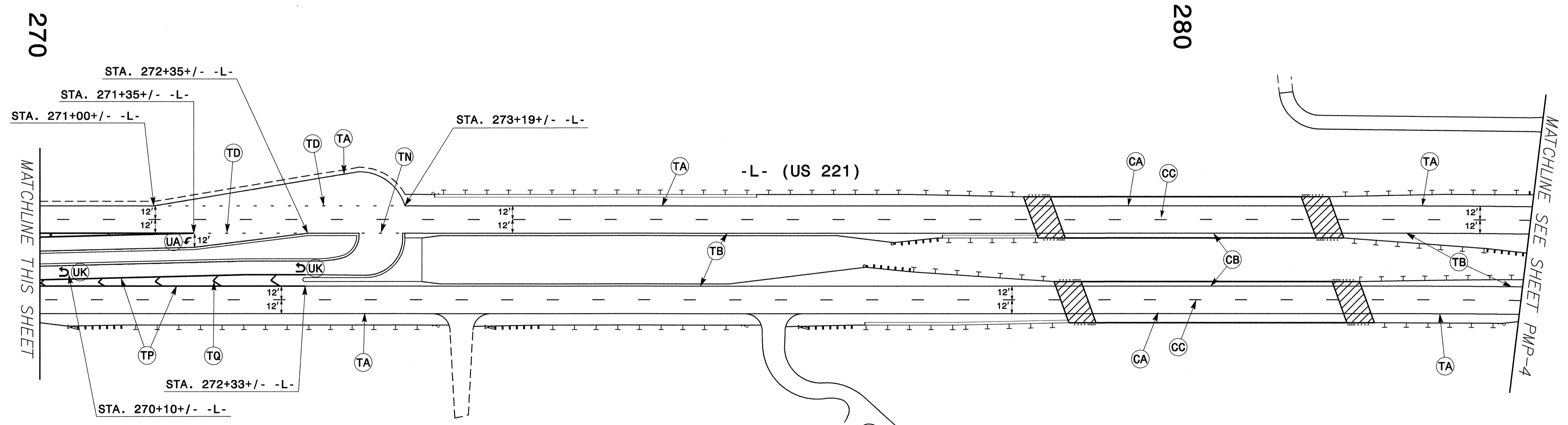
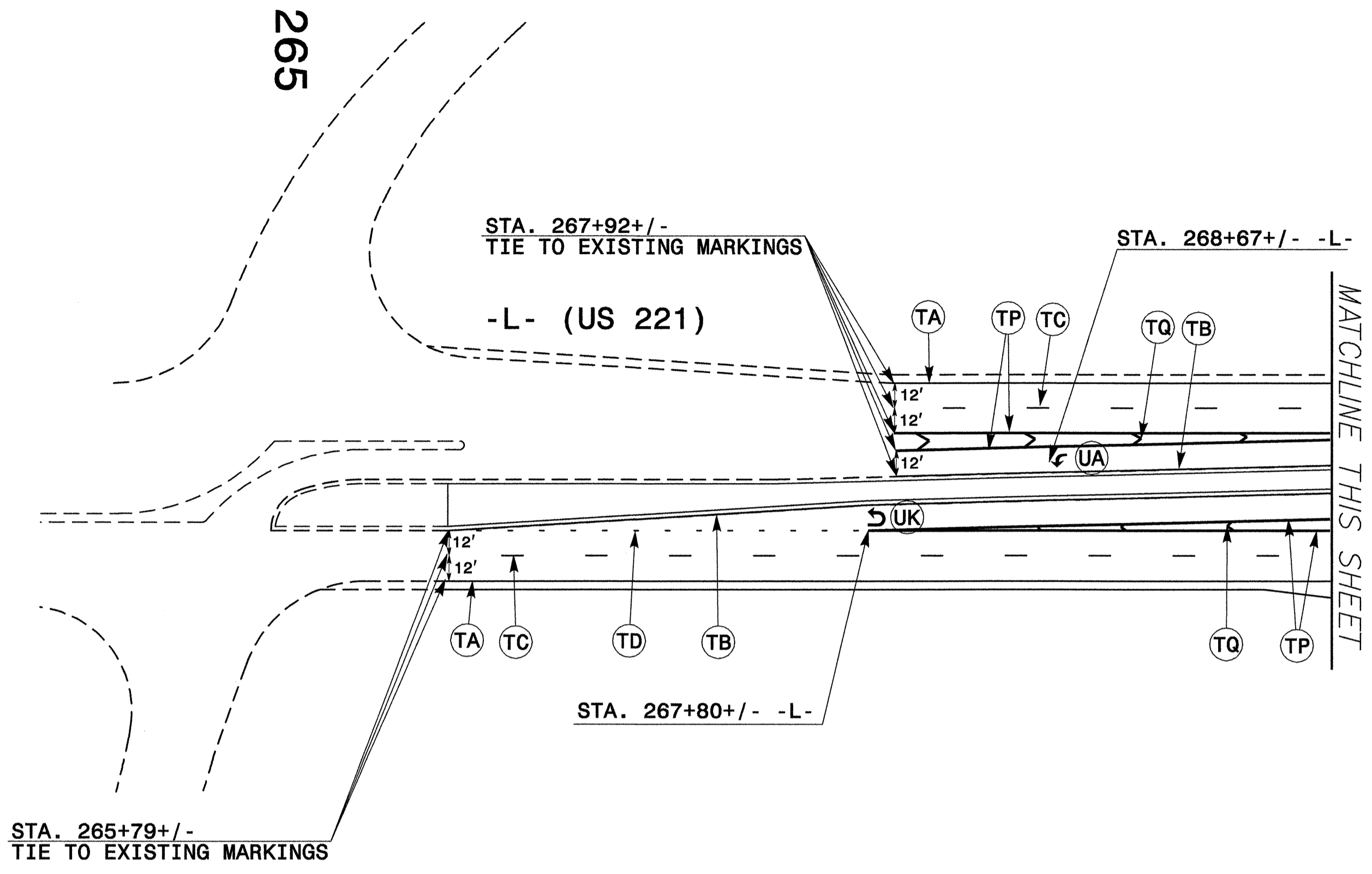

PLAN PREPARED IN THE OFFICE OF  
**PROGRESSIVE**  
 DESIGN GROUP, INC.  
  
 ENGINEERS • CONSULTANTS  
 CHARLOTTE, NC 704.373.5003

**PAVEMENT MARKING DETAIL**

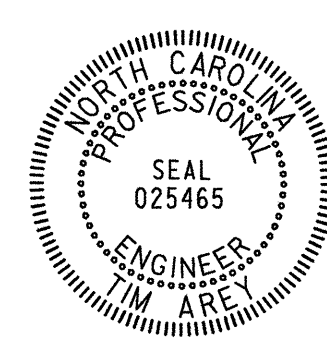
TIP NO. R-2233AB	SHEET NO. PMP-4
APPROVED: <i>[Signature]</i>	
DATE: 6/29/10	
SEAL	
	

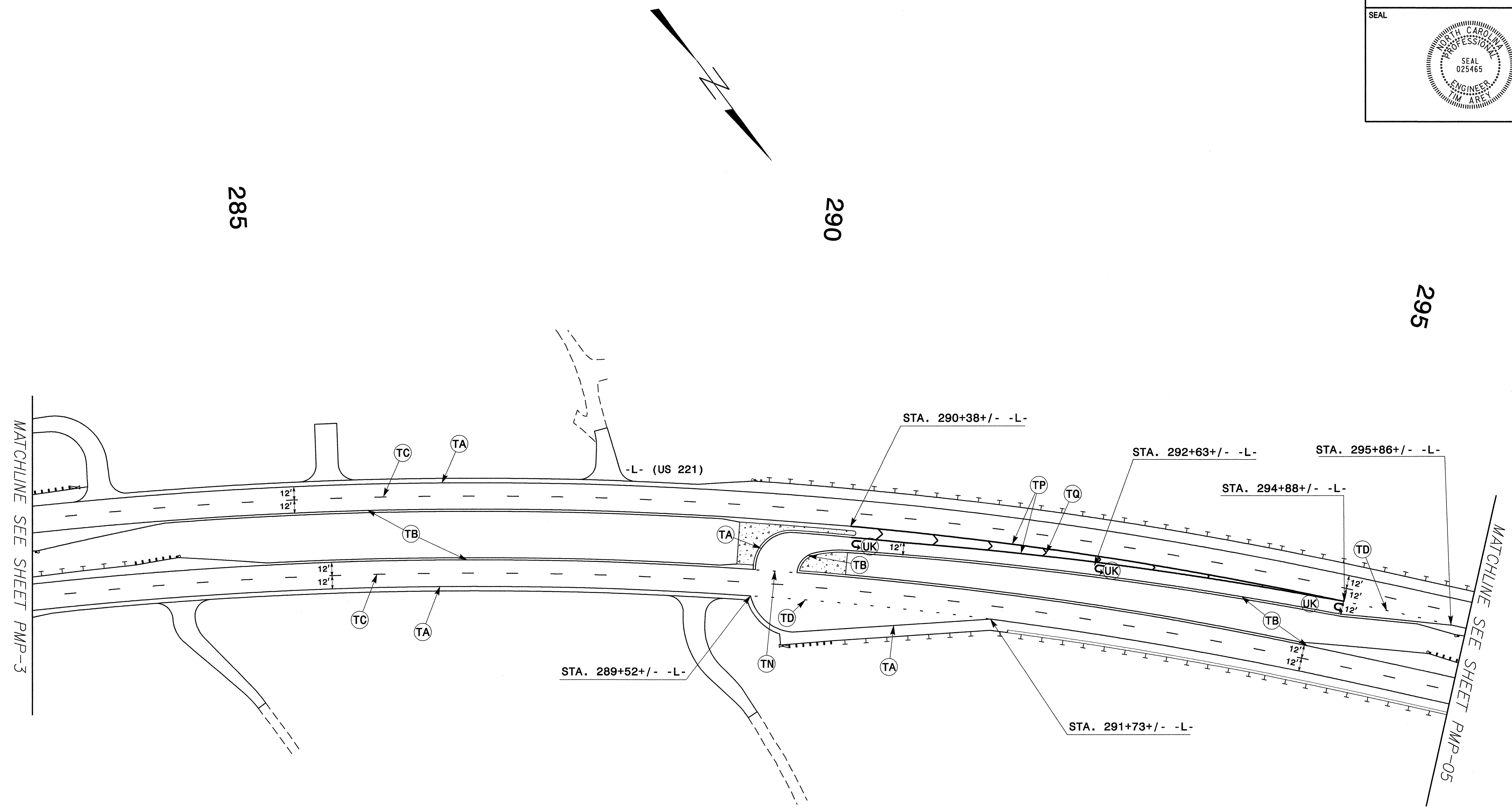

PLAN PREPARED IN THE OFFICE OF  
**PROGRESSIVE**  
 DESIGN GROUP, INC.  
  
 ENGINEERS • CONSULTANTS  
 CHARLOTTE, NC 704.573.5003

**NOTE:**  
 SEE ROADWAY STANDARD FOR PLACEMENT OF SYMBOLS AND  
 CHARACTERS UNLESS OTHERWISE SPECIFIED ON THE PLAN.

**PAVEMENT MARKING DETAIL**

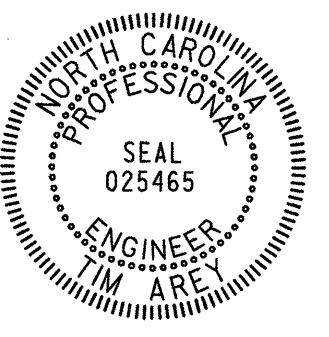
TIP NO. R-2233AB	SHEET NO. PMP-5
APPROVED: <i>[Signature]</i>	
DATE: 6/29/10	
SEAL	
	

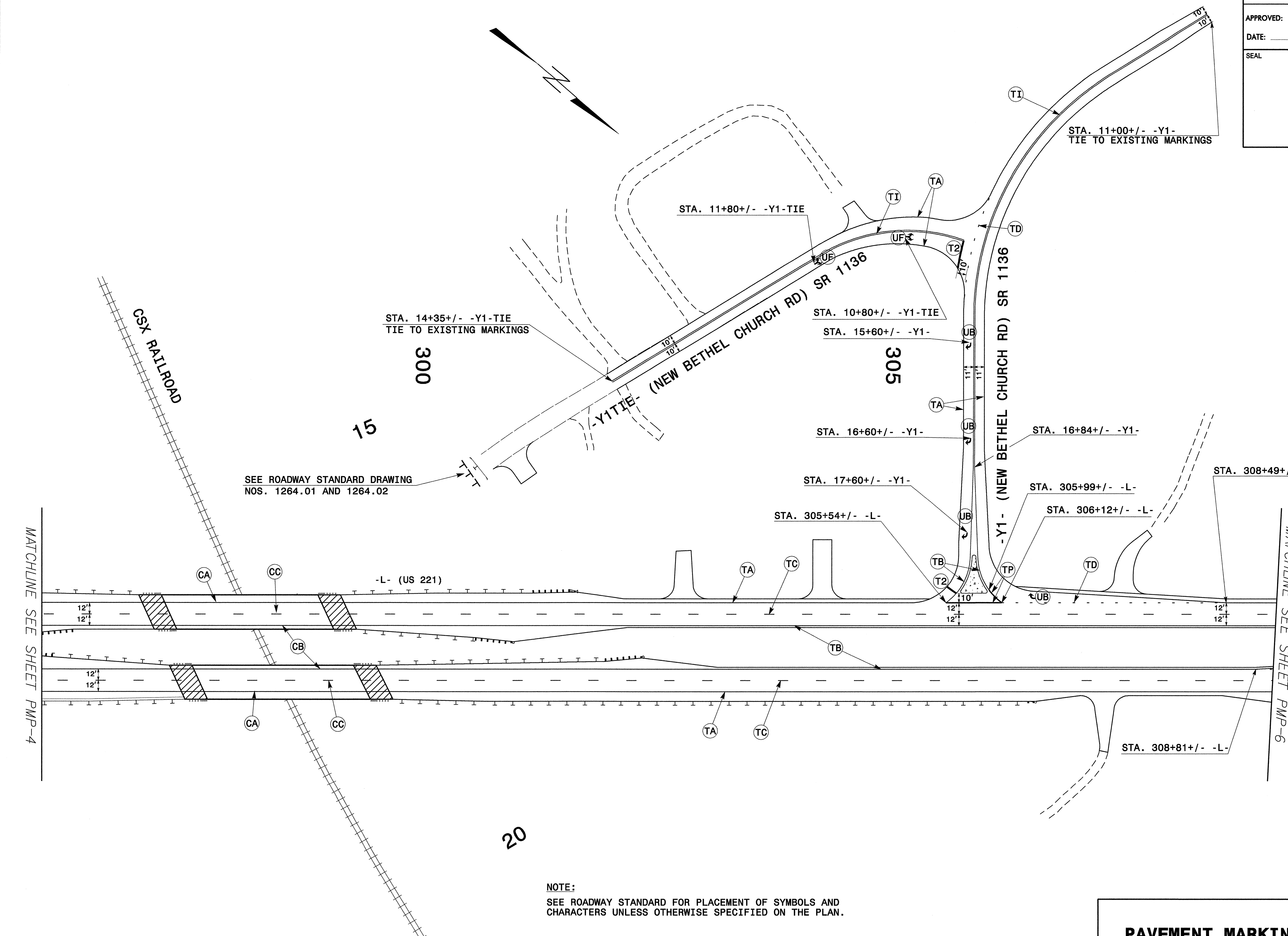

SEE ROADWAY STANDARD DRAWING  
NOS. 1264.01 AND 1264.02

NOTE:  
SEE ROADWAY STANDARD FOR PLACEMENT OF SYMBOLS AND  
CHARACTERS UNLESS OTHERWISE SPECIFIED ON THE PLAN.

**PAVEMENT MARKING DETAIL**

TIP NO. R-2233AB	SHEET NO. PMP-6
APPROVED: <i>J. A. [Signature]</i>	
DATE: 6/29/10	
SEAL	

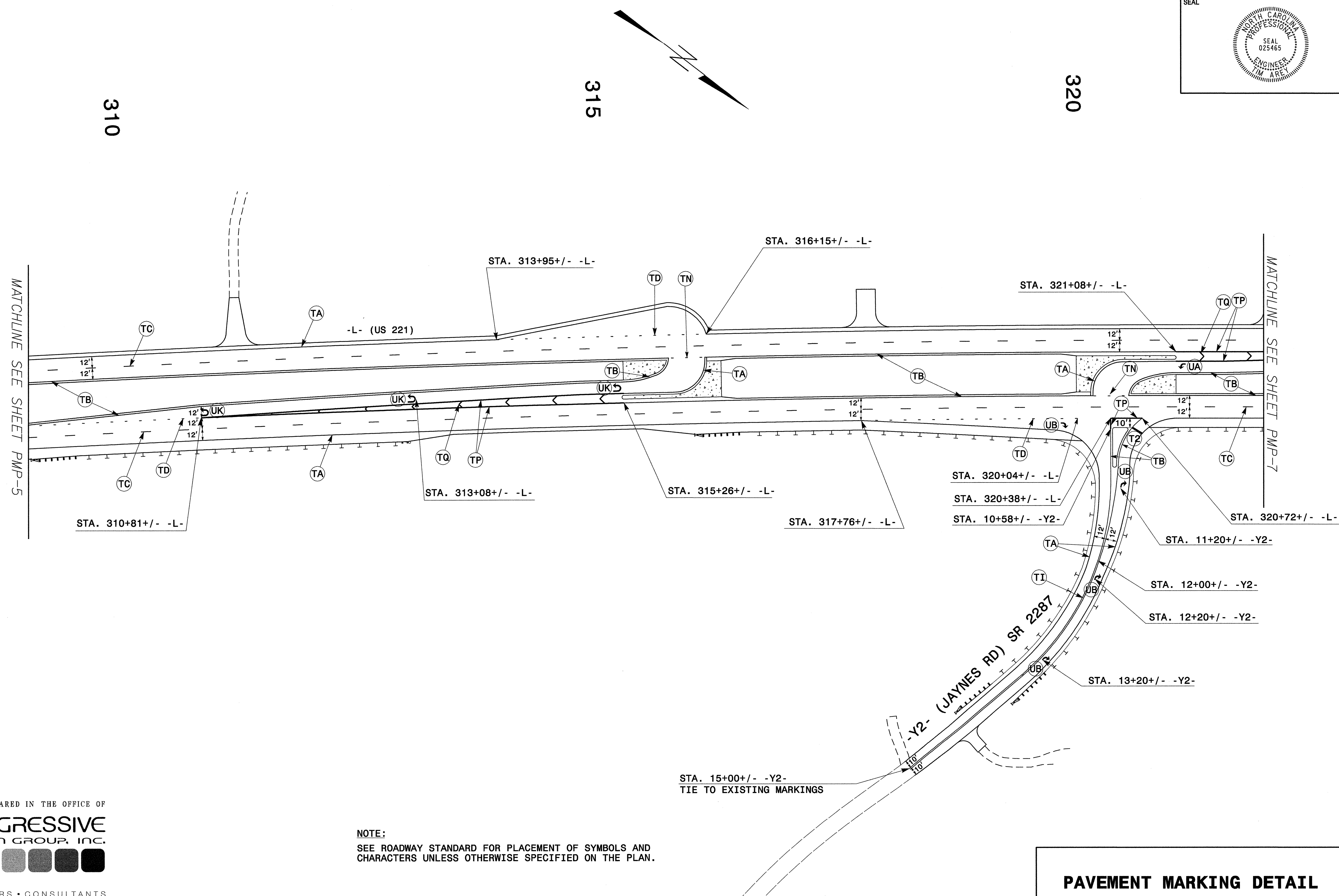

PLAN PREPARED IN THE OFFICE OF  
**PROGRESSIVE**  
 DESIGN GROUP, INC.  
  
 ENGINEERS • CONSULTANTS  
 CHARLOTTE, NC 704.573.5003

**NOTE:**  
 SEE ROADWAY STANDARD FOR PLACEMENT OF SYMBOLS AND CHARACTERS UNLESS OTHERWISE SPECIFIED ON THE PLAN.

**PAVEMENT MARKING DETAIL**

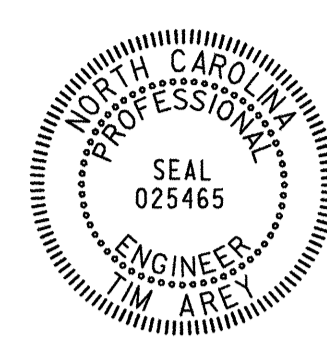
TIP NO. R-2233AB	SHEET NO. PMP-7
APPROVED: <i>Jim Arey</i>	
DATE: 4/29/10	
SEAL	
	

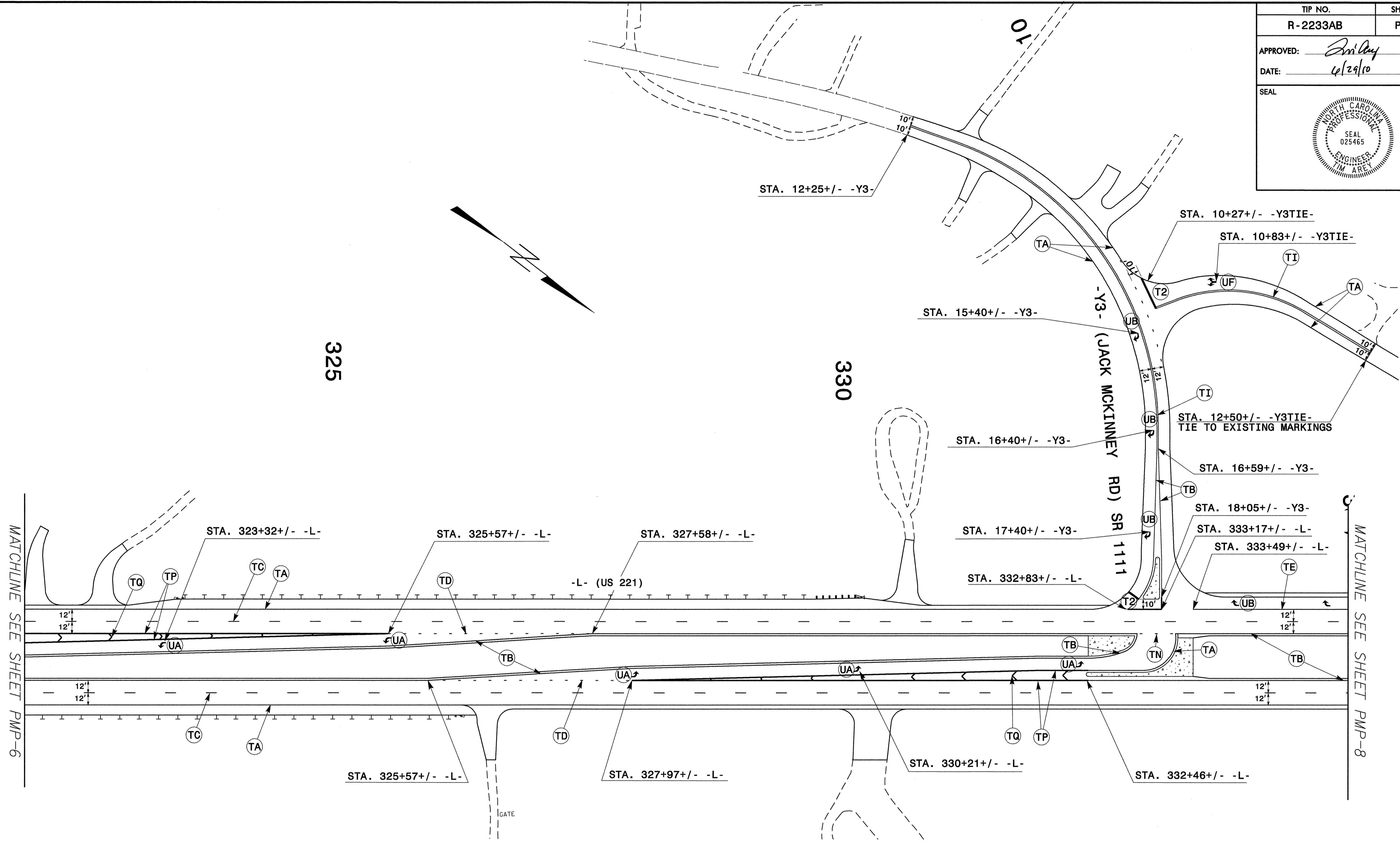

PLAN PREPARED IN THE OFFICE OF  
**PROGRESSIVE**  
 DESIGN GROUP, INC.  
  
 ENGINEERS • CONSULTANTS  
 CHARLOTTE, NC 704.573.5003

**NOTE:**  
 SEE ROADWAY STANDARD FOR PLACEMENT OF SYMBOLS AND  
 CHARACTERS UNLESS OTHERWISE SPECIFIED ON THE PLAN.

**PAVEMENT MARKING DETAIL**

TIP NO. R-2233AB	SHEET NO. PMP-8
APPROVED: <i>Shi Day</i>	
DATE: 6/29/10	
SEAL	

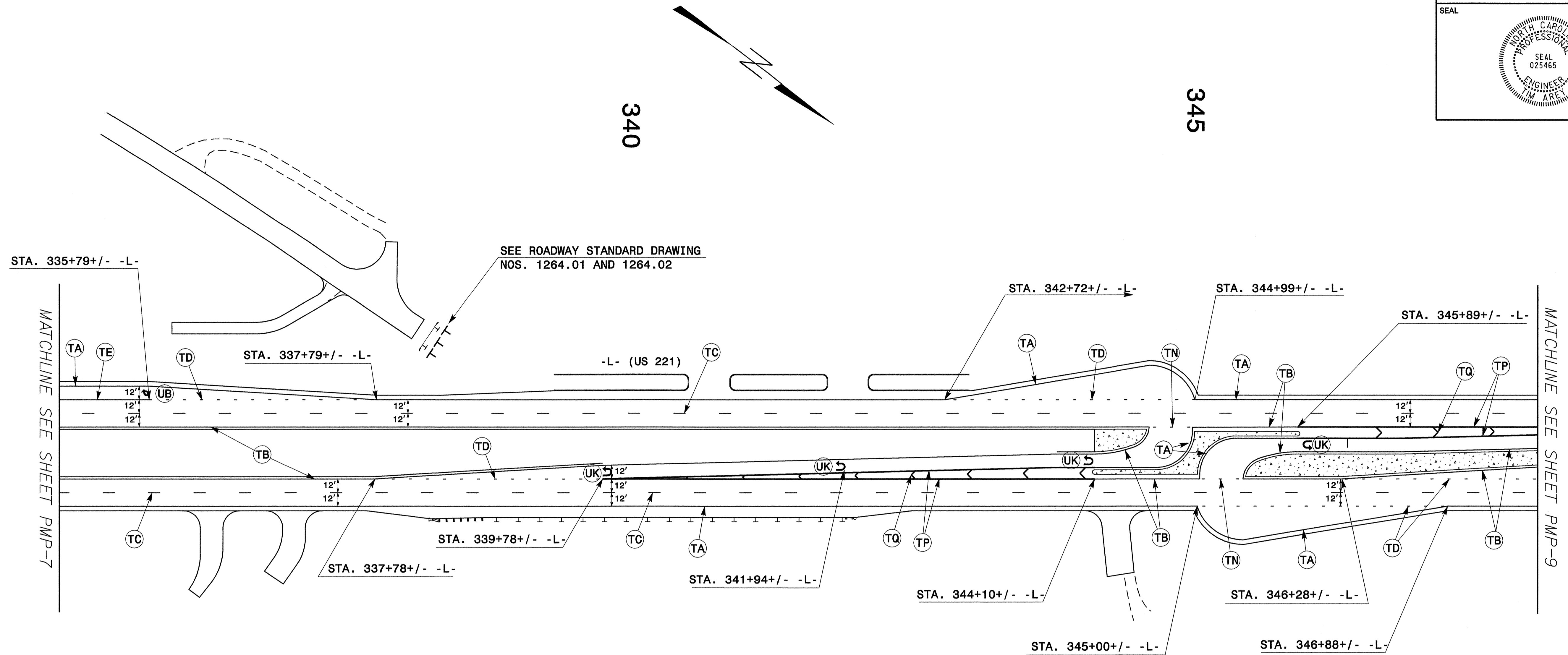

**NOTE:**  
SEE ROADWAY STANDARD FOR PLACEMENT OF SYMBOLS AND  
CHARACTERS UNLESS OTHERWISE SPECIFIED ON THE PLAN.

**PAVEMENT MARKING DETAIL**

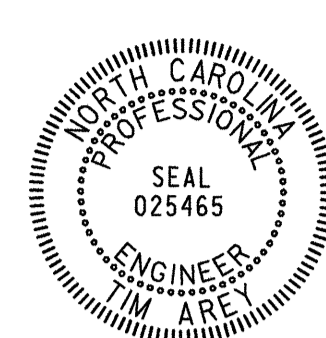

TIP NO. R-2233AB	SHEET NO. PMP-9
APPROVED: <i>[Signature]</i>	
DATE: 6/29/10	
SEAL	
	

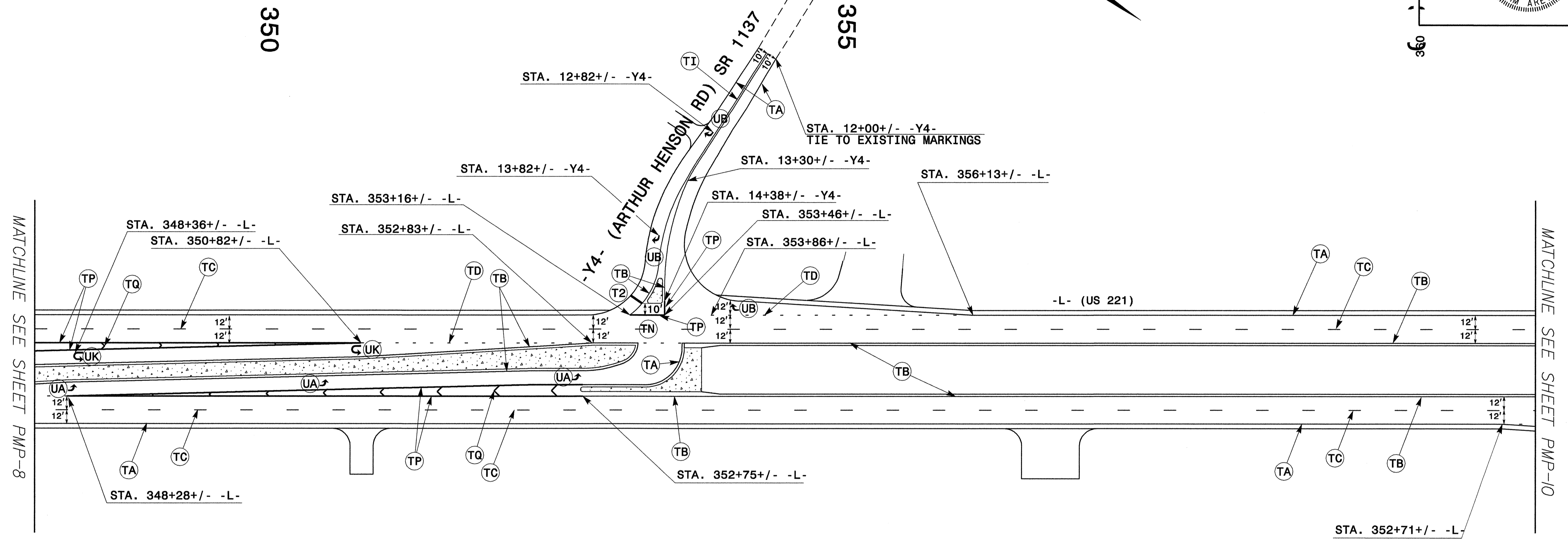

PLAN PREPARED IN THE OFFICE OF  
**PROGRESSIVE**  
 DESIGN GROUP, INC.  
  
 ENGINEERS • CONSULTANTS  
 CHARLOTTE, NC 704.573.5005

NOTE:  
 SEE ROADWAY STANDARD FOR PLACEMENT OF SYMBOLS AND  
 CHARACTERS UNLESS OTHERWISE SPECIFIED ON THE PLAN.

**PAVEMENT MARKING DETAIL**

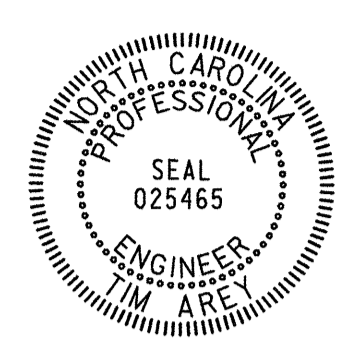
TIP NO. R-2233AB	SHEET NO. PMP-10
APPROVED: <i>Z. Day</i>	
DATE: 6/29/10	
SEAL	
	

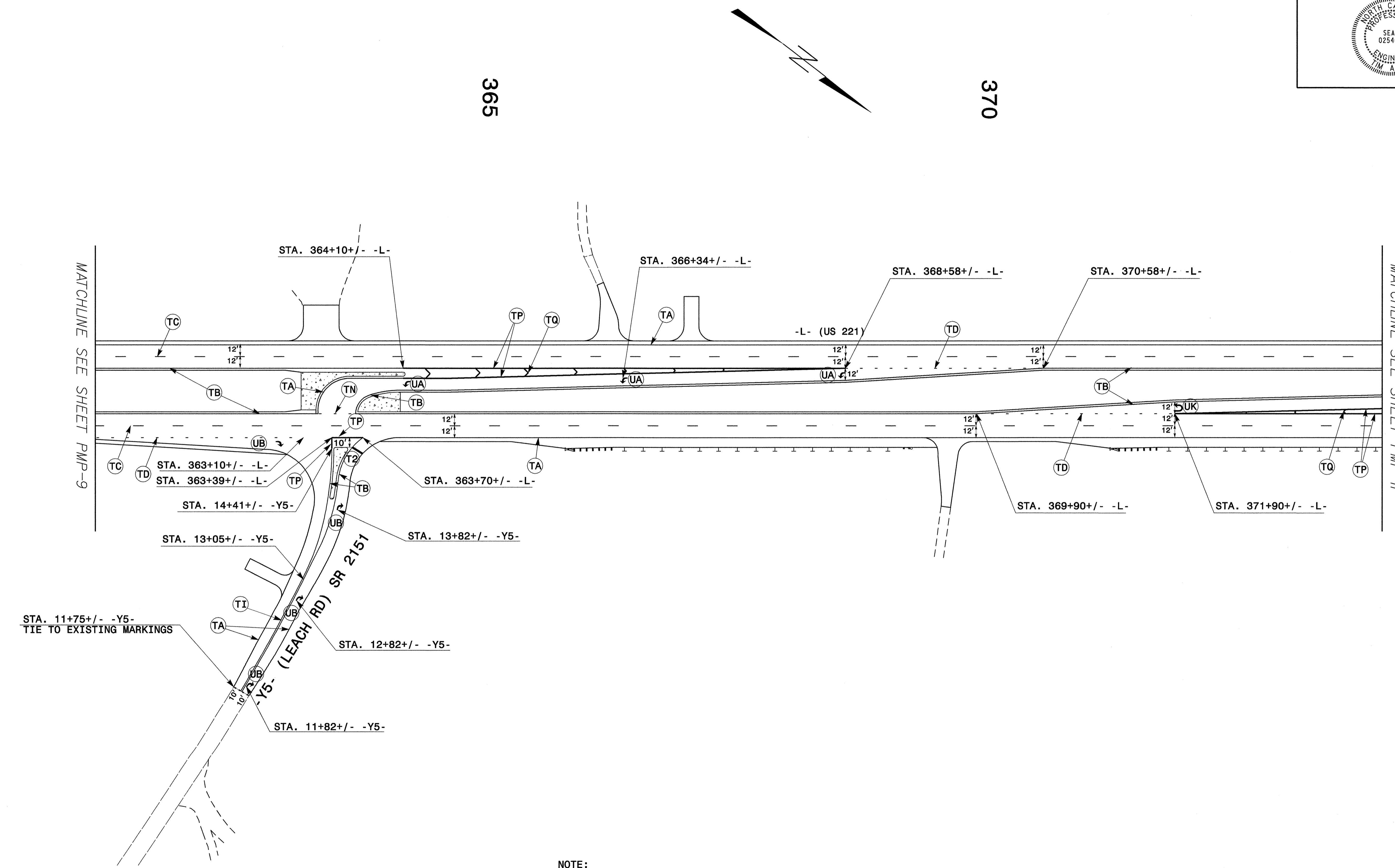

NOTE:  
SEE ROADWAY STANDARD FOR PLACEMENT OF SYMBOLS AND  
CHARACTERS UNLESS OTHERWISE SPECIFIED ON THE PLAN.

**PAVEMENT MARKING DETAIL**

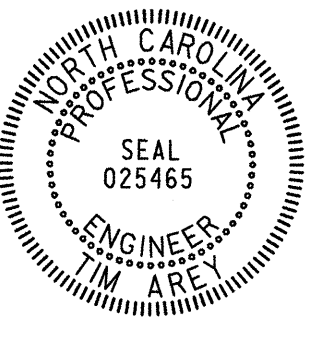
TIP NO. R-2233AB	SHEET NO. PMP-11
APPROVED: <i>[Signature]</i>	
DATE: 6/29/10	
SEAL	
	

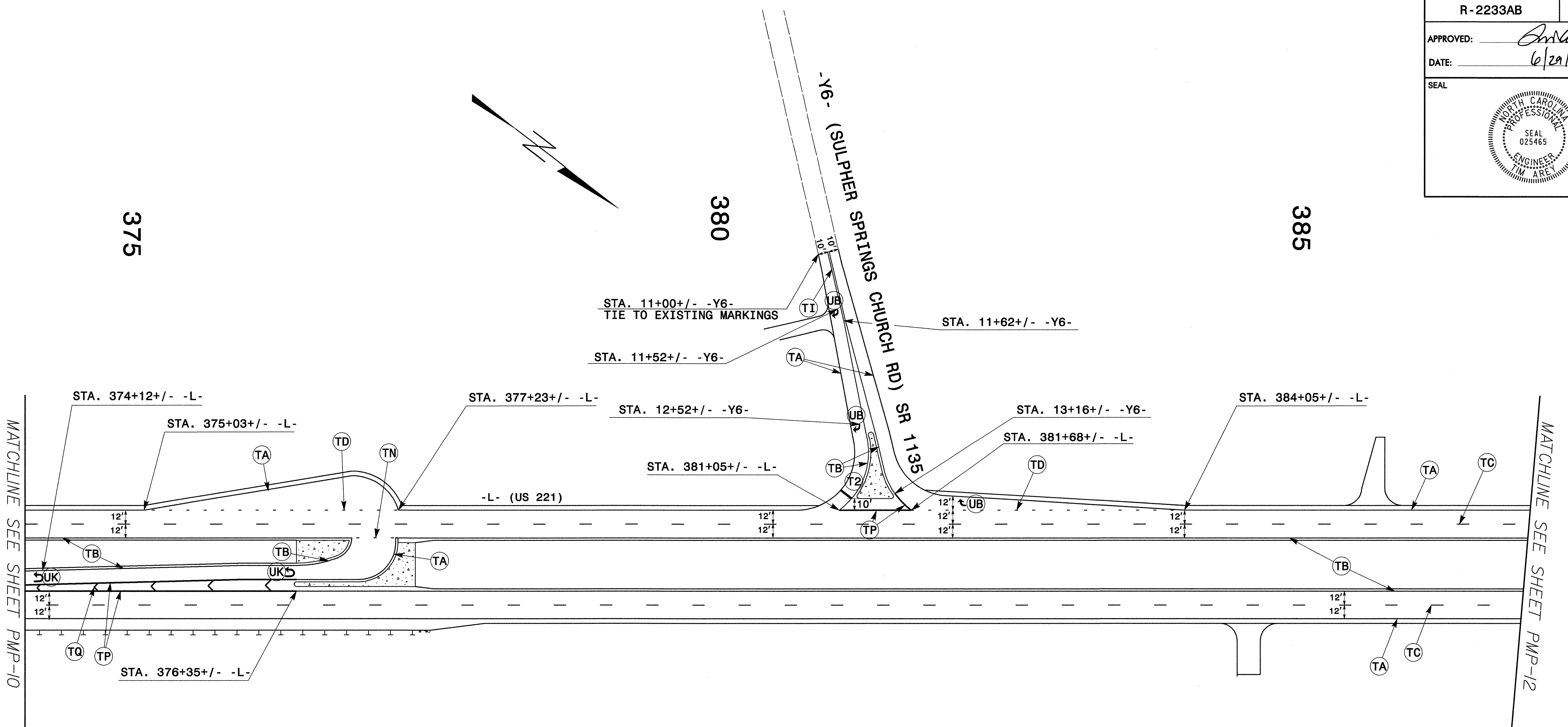

PLAN PREPARED IN THE OFFICE OF  
**PROGRESSIVE**  
 DESIGN GROUP, INC.  
  
 ENGINEERS • CONSULTANTS  
 CHARLOTTE, NC 704.573.5005

NOTE:  
 SEE ROADWAY STANDARD FOR PLACEMENT OF SYMBOLS AND  
 CHARACTERS UNLESS OTHERWISE SPECIFIED ON THE PLAN.

**PAVEMENT MARKING DETAIL**

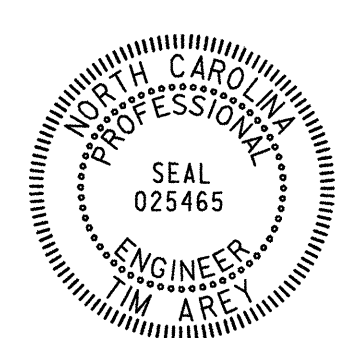
TIP NO. R-2233AB	SHEET NO. PMP-12
APPROVED: <i>[Signature]</i>	
DATE: 6/29/10	
SEAL	
	

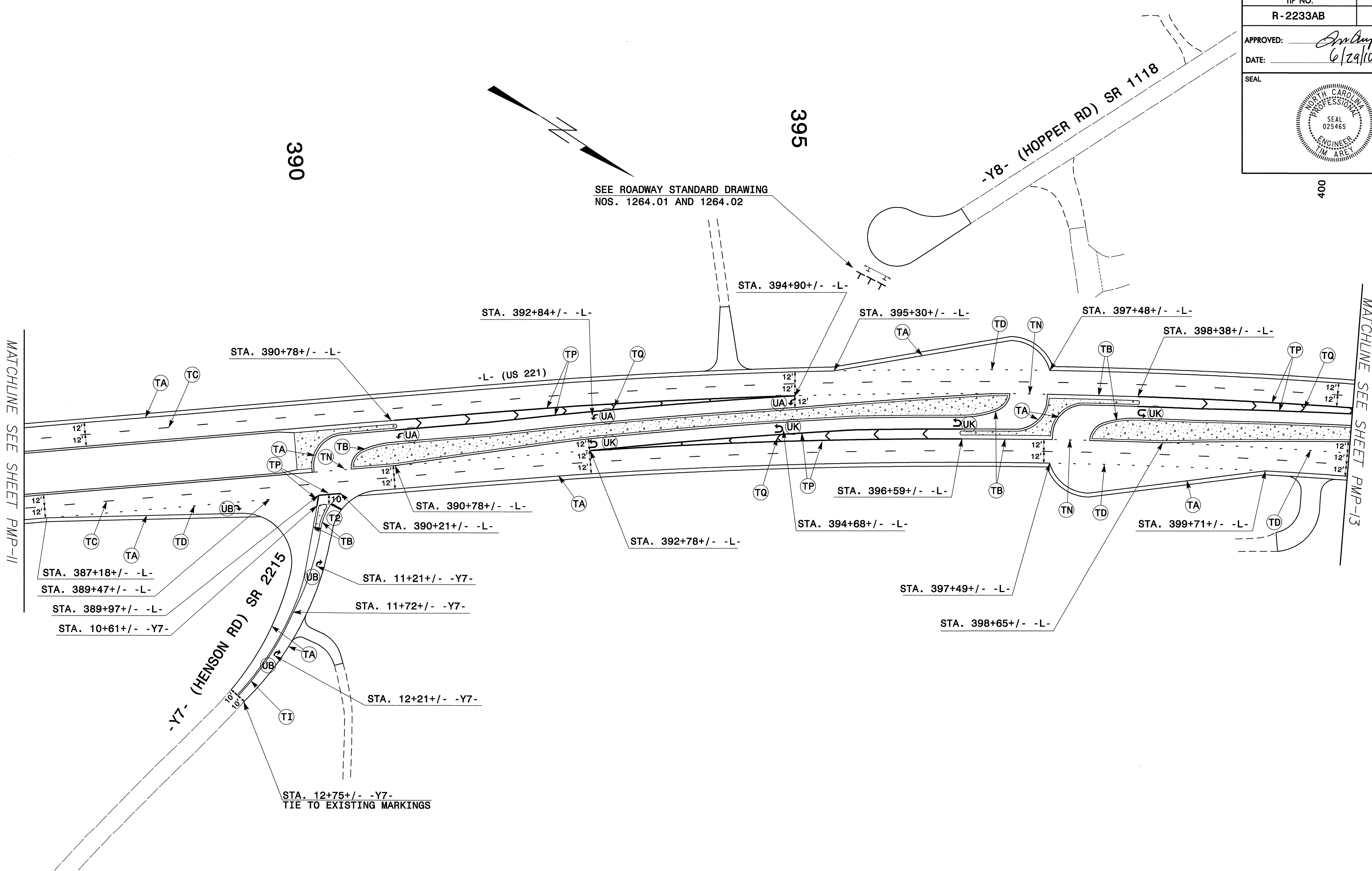

PLAN PREPARED IN THE OFFICE OF  
**PROGRESSIVE**  
 DESIGN GROUP, INC.  
  
 ENGINEERS • CONSULTANTS  
 CHARLOTTE, NC 704.573.3003

**NOTE:**  
 SEE ROADWAY STANDARD FOR PLACEMENT OF SYMBOLS AND CHARACTERS UNLESS OTHERWISE SPECIFIED ON THE PLAN.

**PAVEMENT MARKING DETAIL**

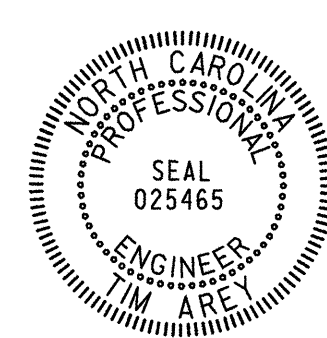
TIP NO. R-2233AB	SHEET NO. PMP-13
APPROVED: <i>[Signature]</i>	
DATE: 6/29/10	
SEAL 	

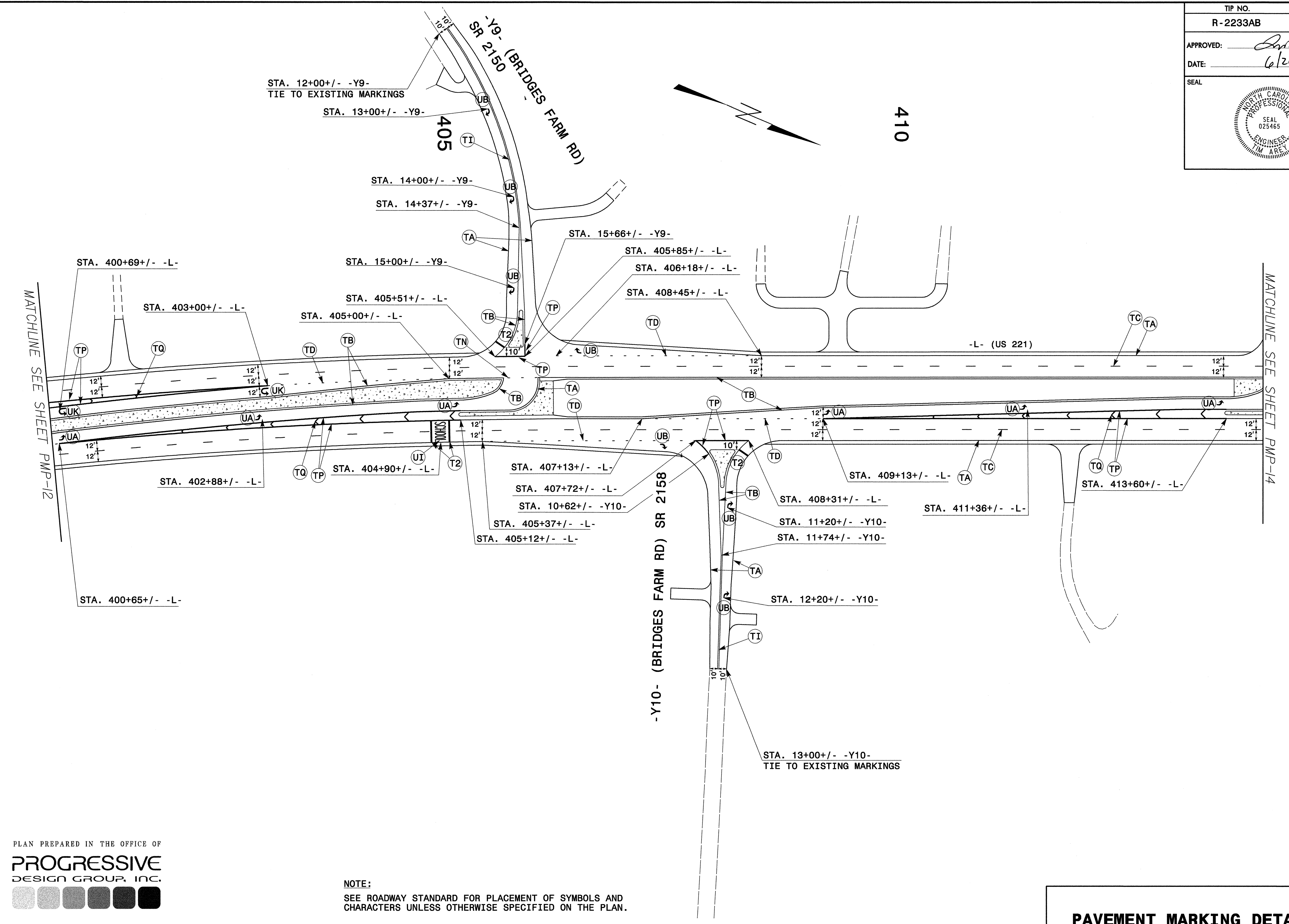

PLAN PREPARED IN THE OFFICE OF  
**PROGRESSIVE**  
 DESIGN GROUP, INC.  
  
 ENGINEERS • CONSULTANTS  
 CHARLOTTE, NC 704.573.3003

**NOTE:**  
 SEE ROADWAY STANDARD FOR PLACEMENT OF SYMBOLS AND  
 CHARACTERS UNLESS OTHERWISE SPECIFIED ON THE PLAN.

**PAVEMENT MARKING DETAIL**

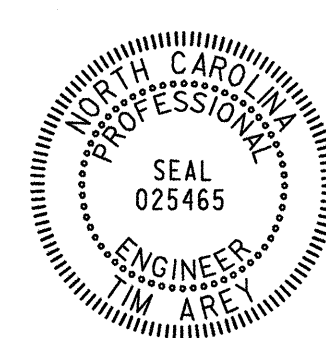
TIP NO. R-2233AB	SHEET NO. PMP-14
APPROVED: <i>Antony</i>	
DATE: 6/29/10	
SEAL	
	

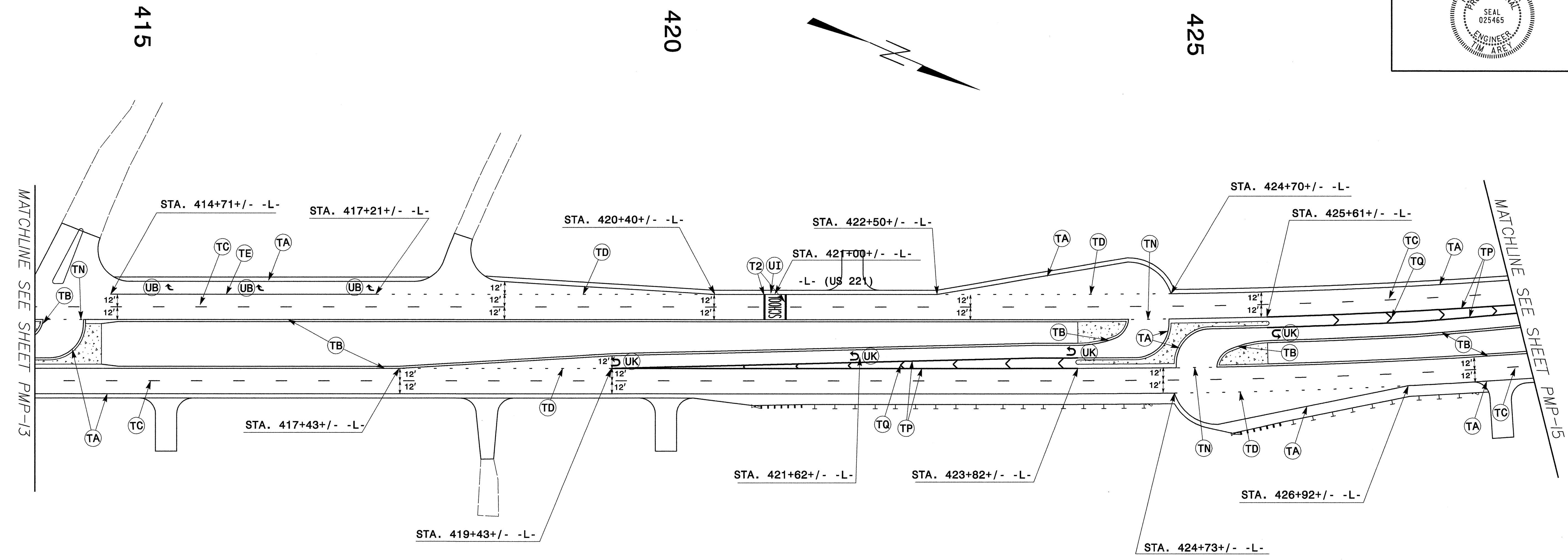

PLAN PREPARED IN THE OFFICE OF  
**PROGRESSIVE**  
 DESIGN GROUP, INC.  
  
 ENGINEERS • CONSULTANTS  
 CHARLOTTE, NC 704.573.3003

**PAVEMENT MARKING DETAIL**

TIP NO. R-2233AB	SHEET NO. PMP-15
APPROVED: <i>Steve Ruff</i>	
DATE: 6/29/10	
SEAL	

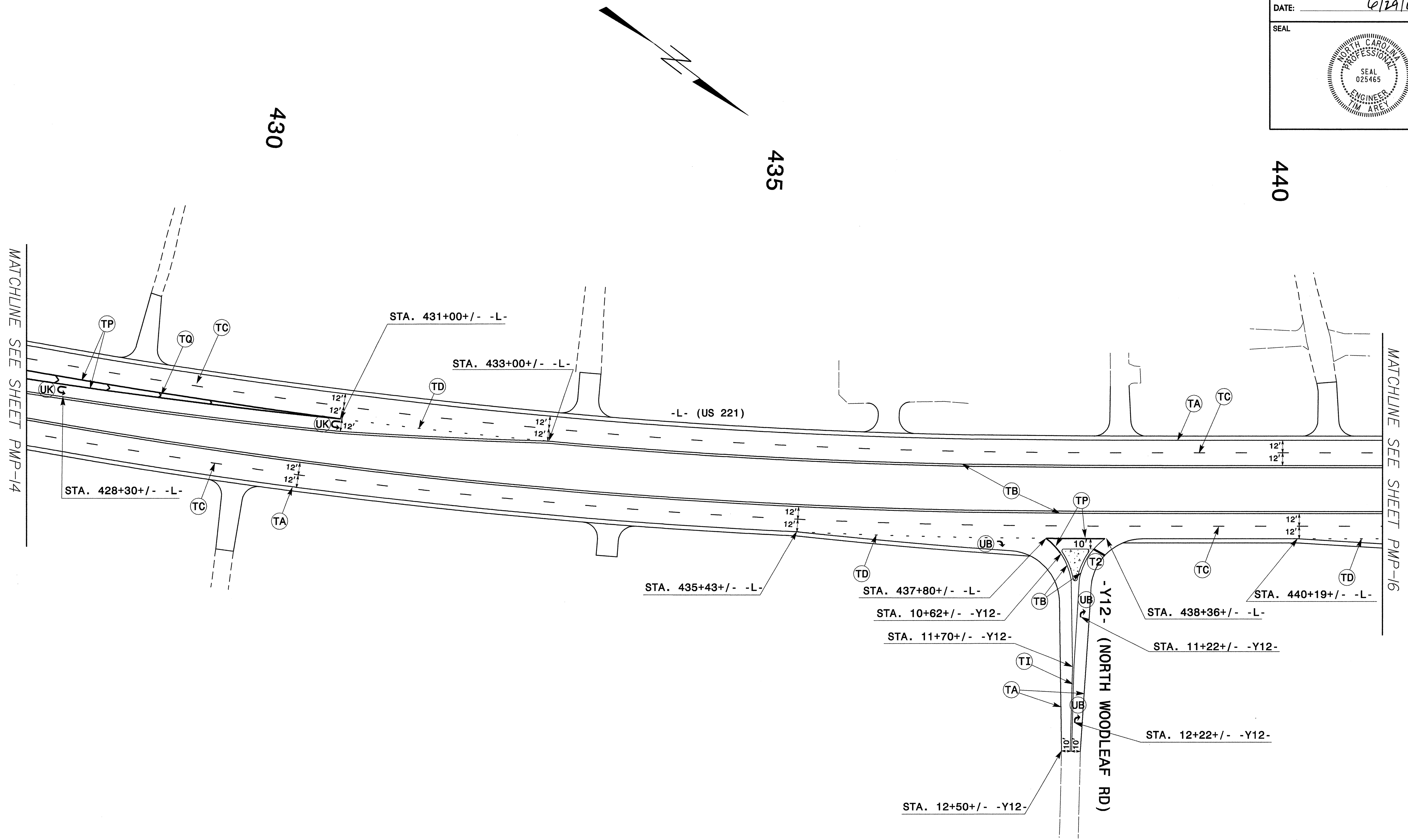

PLAN PREPARED IN THE OFFICE OF  
**PROGRESSIVE**  
 DESIGN GROUP, INC.  
  
 ENGINEERS • CONSULTANTS  
 CHARLOTTE, NC 704.373.5005

**PAVEMENT MARKING DETAIL**

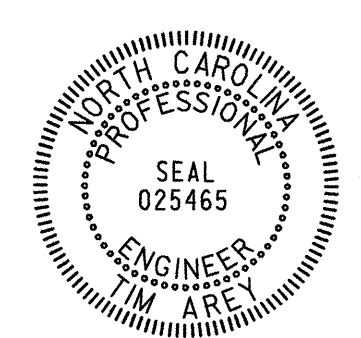
TIP NO. R-2233AB	SHEET NO. PMP-16
APPROVED: <i>[Signature]</i>	
DATE: 6/29/10	
SEAL	
	

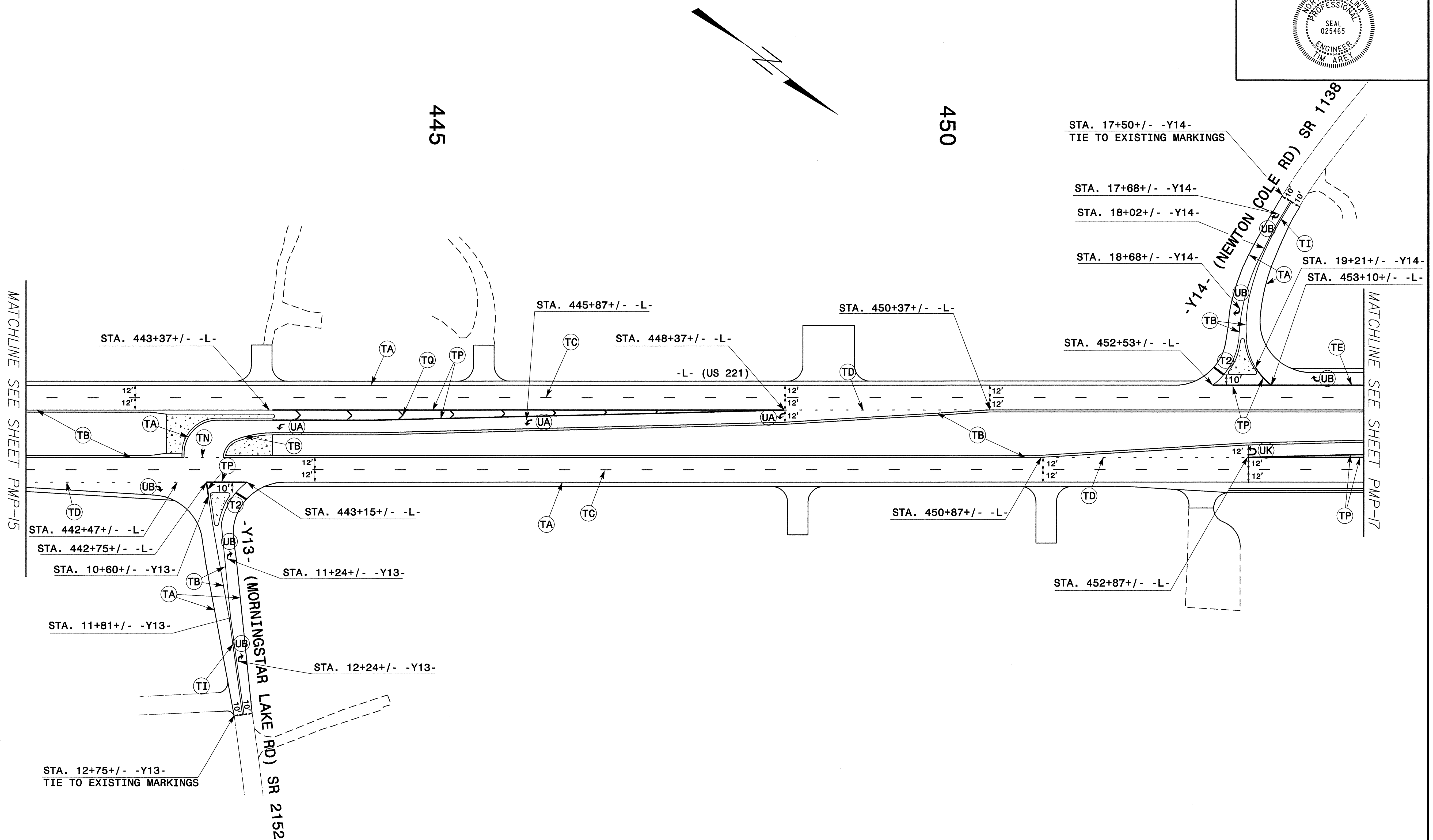

NOTE:  
SEE ROADWAY STANDARD FOR PLACEMENT OF SYMBOLS AND CHARACTERS UNLESS OTHERWISE SPECIFIED ON THE PLAN.

**PAVEMENT MARKING DETAIL**

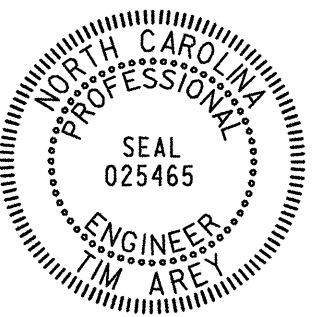

TIP NO.	SHEET NO.
R-2233AB	PMP-17
APPROVED: <i>[Signature]</i>	
DATE: 6/29/16	
SEAL	
	

455

460

465

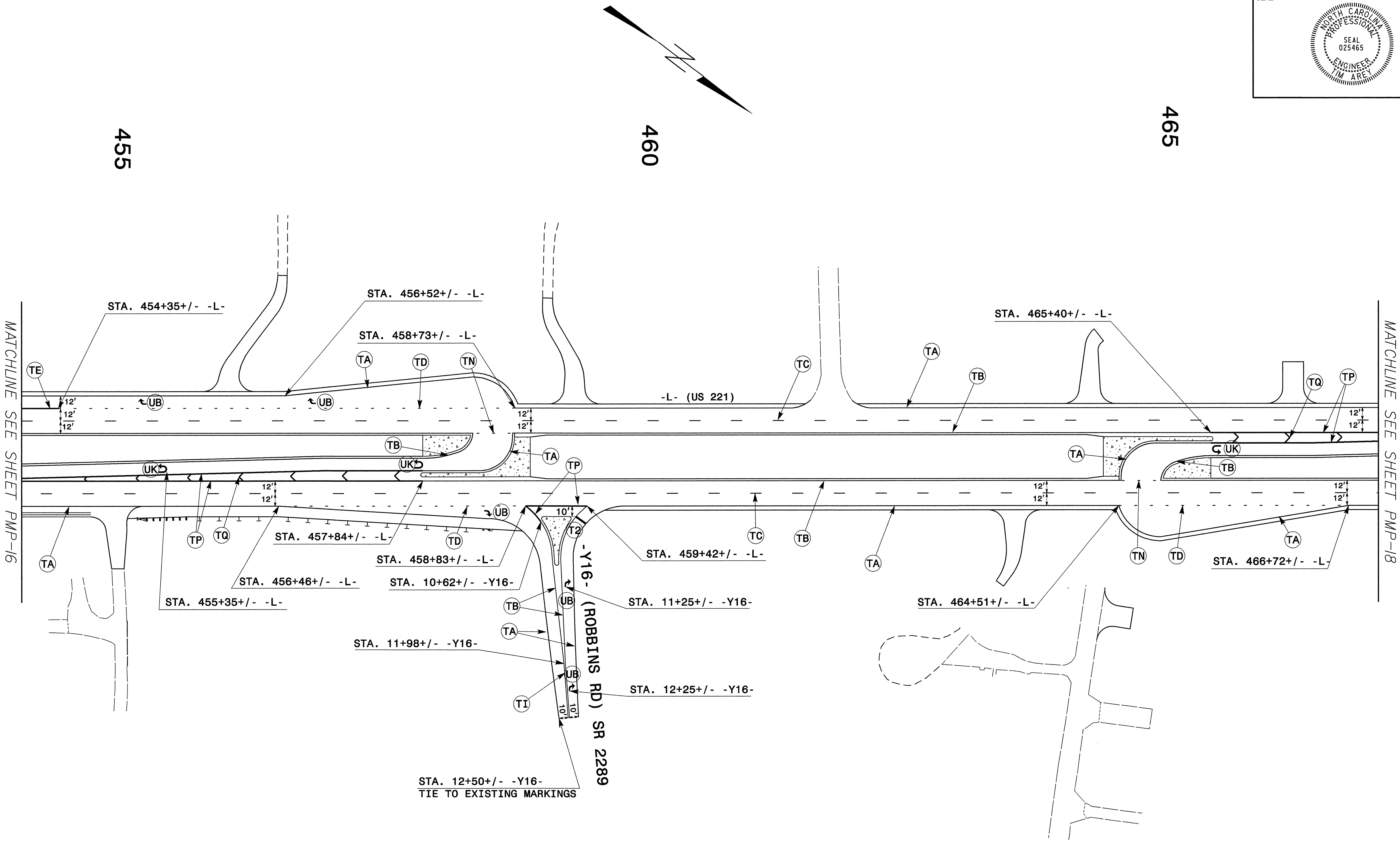

MATCHLINE SEE SHEET PMP-16

MATCHLINE SEE SHEET PMP-18

PLAN PREPARED IN THE OFFICE OF  
**PROGRESSIVE**  
 DESIGN GROUP, INC.  
  
 ENGINEERS • CONSULTANTS  
 CHARLOTTE, NC 704.573.3003

**NOTE:**  
 SEE ROADWAY STANDARD FOR PLACEMENT OF SYMBOLS AND  
 CHARACTERS UNLESS OTHERWISE SPECIFIED ON THE PLAN.

**PAVEMENT MARKING DETAIL**

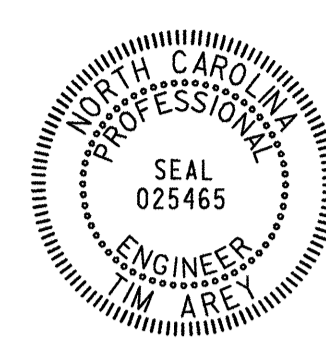
TIP NO. R-2233AB	SHEET NO. PMP-18
APPROVED: <i>[Signature]</i>	
DATE: 6/29/10	
SEAL	
	

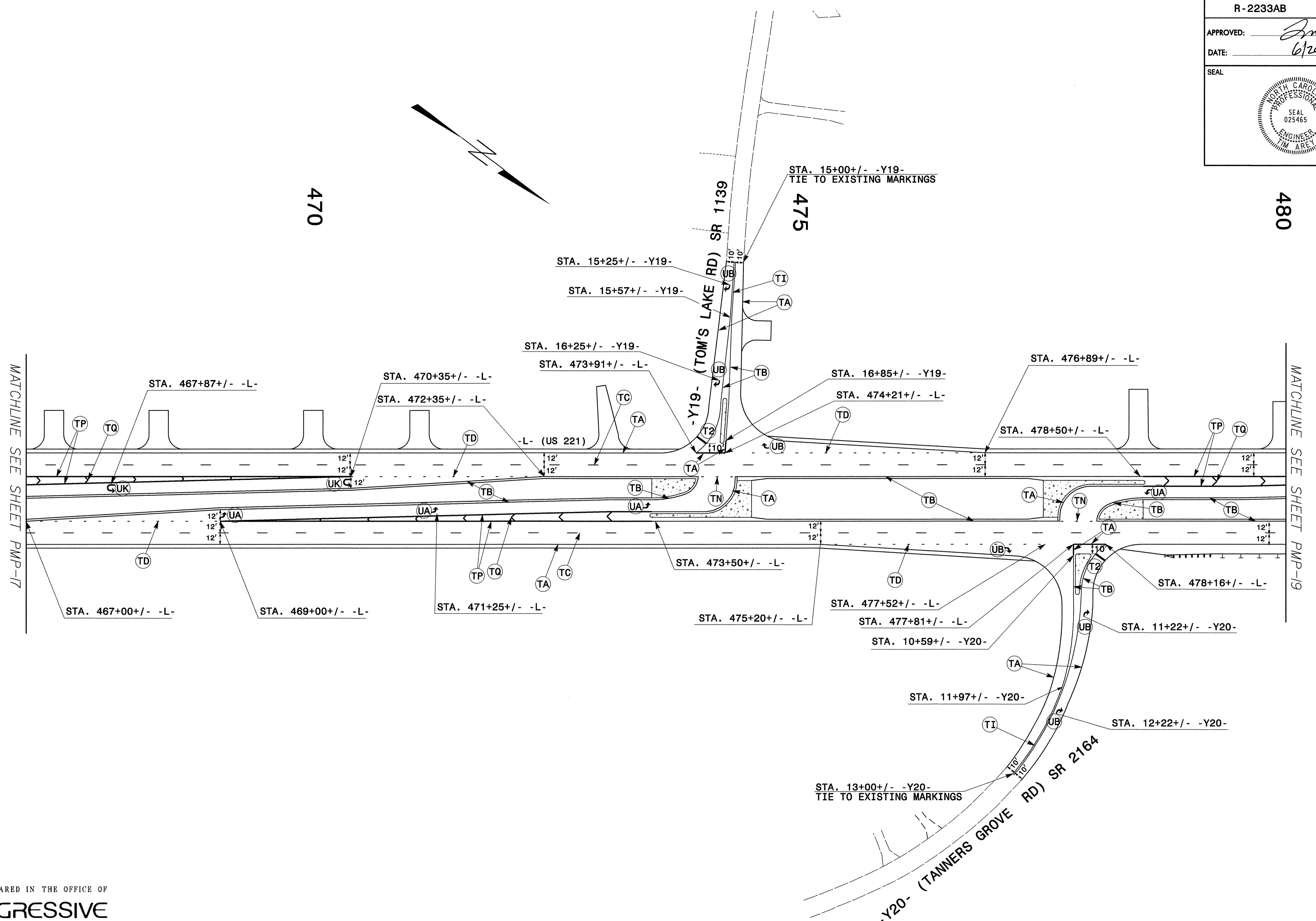

PLAN PREPARED IN THE OFFICE OF  
**PROGRESSIVE**  
 DESIGN GROUP, INC.  
  
 ENGINEERS • CONSULTANTS  
 CHARLOTTE, NC 704.573.3003

NOTE:  
 SEE ROADWAY STANDARD FOR PLACEMENT OF SYMBOLS AND  
 CHARACTERS UNLESS OTHERWISE SPECIFIED ON THE PLAN.

**PAVEMENT MARKING DETAIL**

TIP NO. R-2233AB	SHEET NO. PMP-19
APPROVED: <i>J. M. [Signature]</i>	
DATE: 6/29/10	
SEAL	

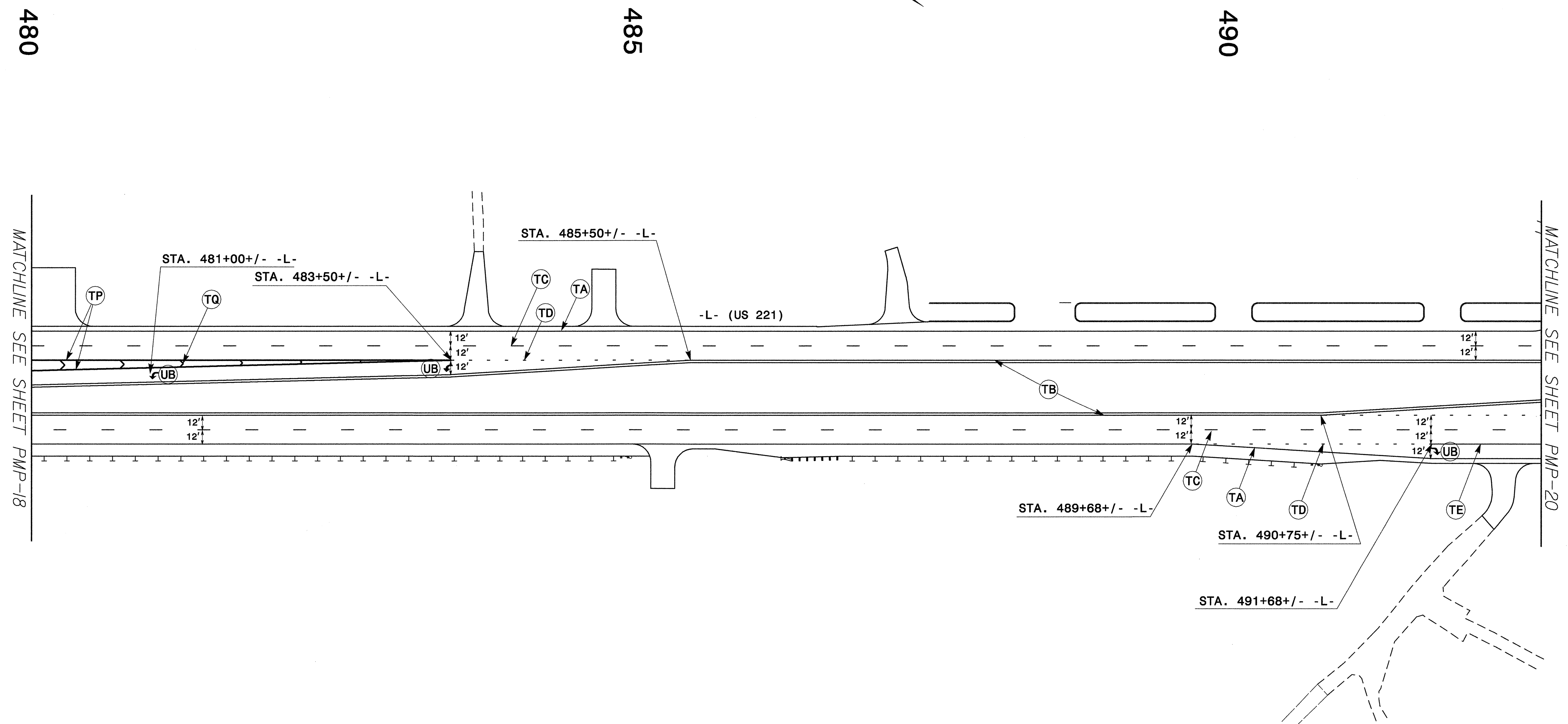

PLAN PREPARED IN THE OFFICE OF  
**PROGRESSIVE**  
 DESIGN GROUP, INC.  
  
 ENGINEERS • CONSULTANTS  
 CHARLOTTE, NC 704.573.5003

**NOTE:**  
 SEE ROADWAY STANDARD FOR PLACEMENT OF SYMBOLS AND  
 CHARACTERS UNLESS OTHERWISE SPECIFIED ON THE PLAN.

**PAVEMENT MARKING DETAIL**

TIP NO. R-2233AB	SHEET NO. PMP-20
APPROVED: <i>[Signature]</i>	
DATE: 6/29/10	
SEAL	

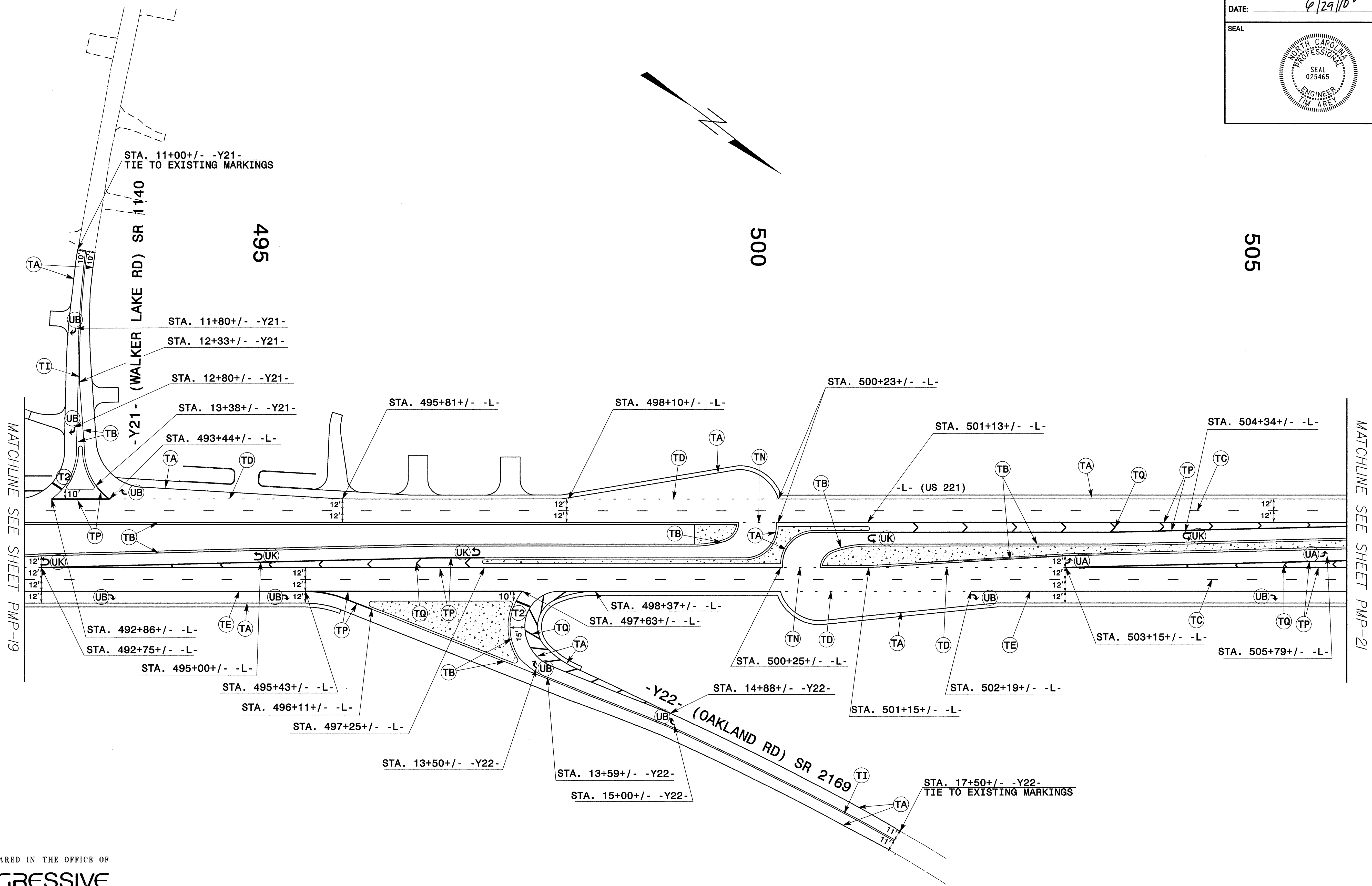

PLAN PREPARED IN THE OFFICE OF  
**PROGRESSIVE**  
 DESIGN GROUP, INC.  
  
 ENGINEERS • CONSULTANTS  
 CHARLOTTE, NC 704.573.3003

**NOTE:**  
 SEE ROADWAY STANDARD FOR PLACEMENT OF SYMBOLS AND CHARACTERS UNLESS OTHERWISE SPECIFIED ON THE PLAN.

**PAVEMENT MARKING DETAIL**

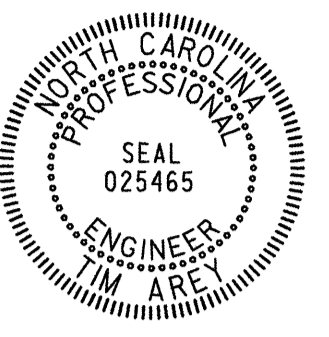
TIP NO. R - 2233AB	SHEET NO. PMP - 21
APPROVED: <i>[Signature]</i>	
DATE: 6/29/10	
SEAL	
	

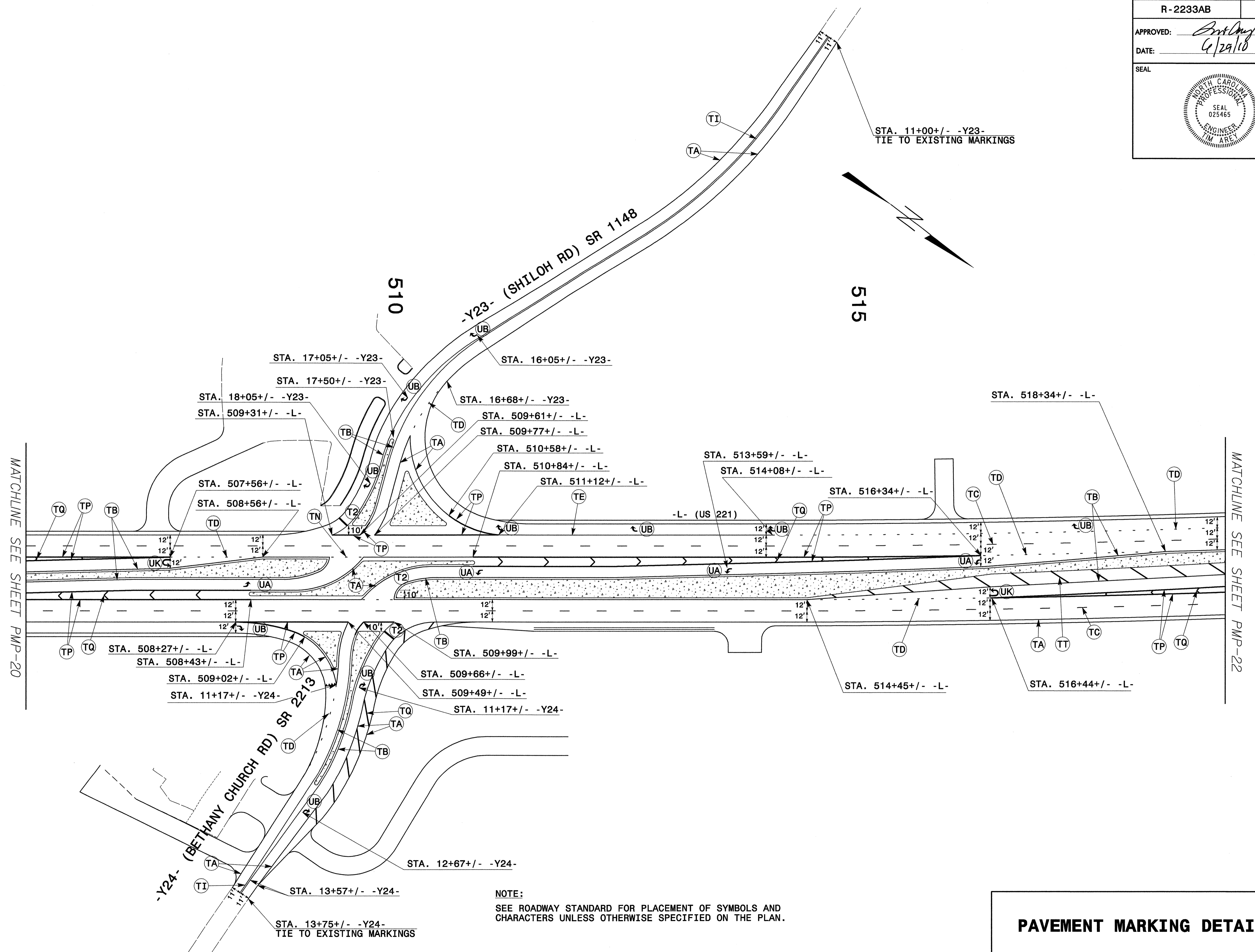

NOTE:  
SEE ROADWAY STANDARD FOR PLACEMENT OF SYMBOLS AND  
CHARACTERS UNLESS OTHERWISE SPECIFIED ON THE PLAN.

**PAVEMENT MARKING DETAIL**

TIP NO. R - 2233AB	SHEET NO. PMP - 22
APPROVED: <i>[Signature]</i>	
DATE: 6/29/10	
SEAL	

520

525

530

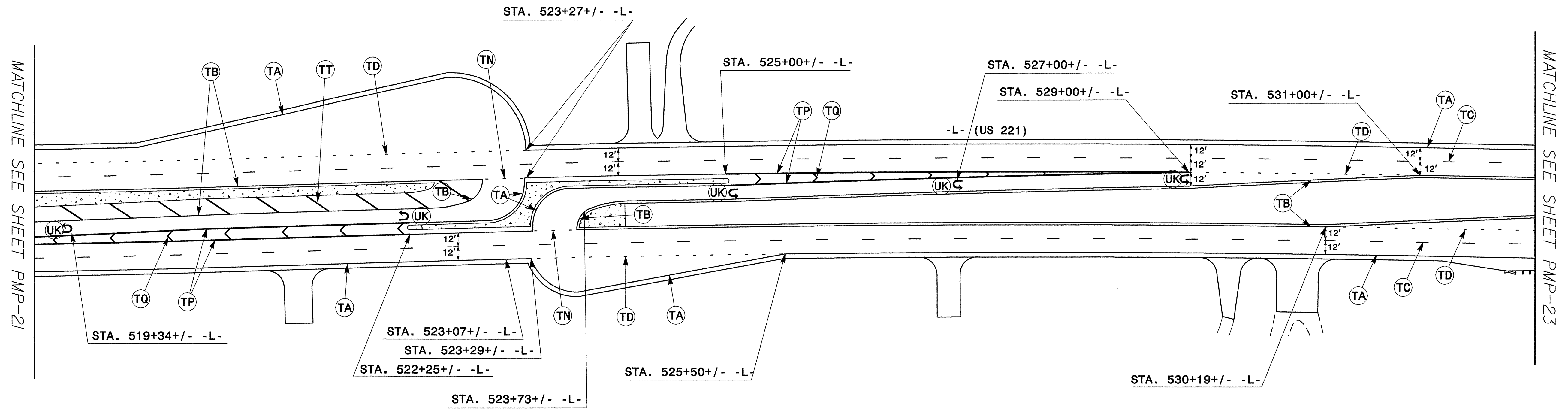

PLAN PREPARED IN THE OFFICE OF  
**PROGRESSIVE**  
 DESIGN GROUP, INC.  
  
 ENGINEERS • CONSULTANTS  
 CHARLOTTE, NC 704.573.3003

NOTE:  
 SEE ROADWAY STANDARD FOR PLACEMENT OF SYMBOLS AND  
 CHARACTERS UNLESS OTHERWISE SPECIFIED ON THE PLAN.

**PAVEMENT MARKING DETAIL**

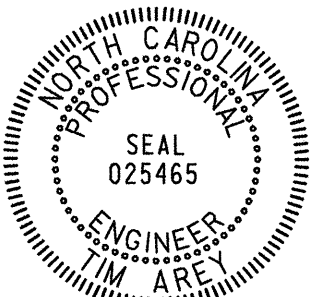
TIP NO. R - 2233AB	SHEET NO. PMP - 23
APPROVED: <i>[Signature]</i>	
DATE: 6/29/10	
SEAL	
	

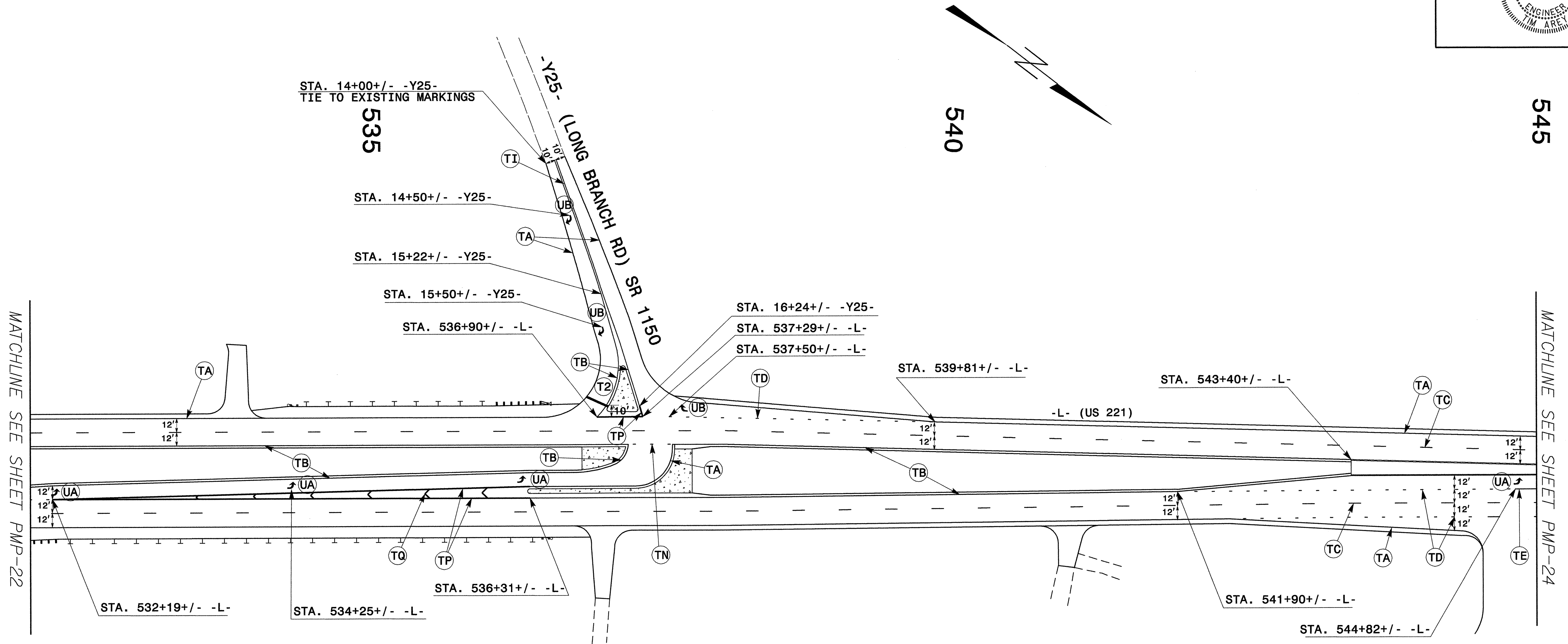

PLAN PREPARED IN THE OFFICE OF  
**PROGRESSIVE**  
 DESIGN GROUP, INC.  
  
 ENGINEERS • CONSULTANTS  
 CHARLOTTE, NC 704.575.3003

NOTE:  
 SEE ROADWAY STANDARD FOR PLACEMENT OF SYMBOLS AND  
 CHARACTERS UNLESS OTHERWISE SPECIFIED ON THE PLAN.

**PAVEMENT MARKING DETAIL**

545

550

555

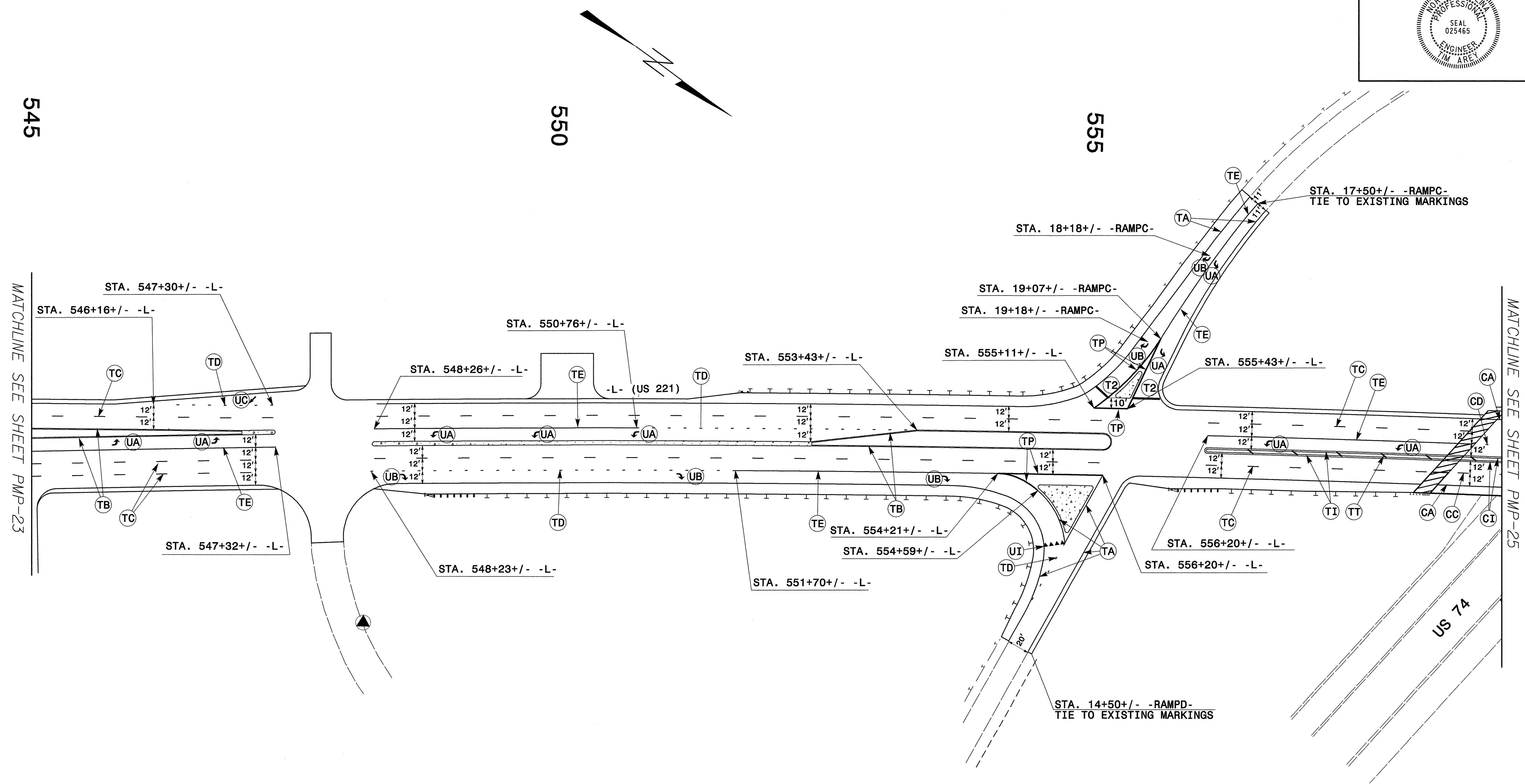

**NOTE:**  
 SEE ROADWAY STANDARD FOR PLACEMENT OF SYMBOLS AND CHARACTERS UNLESS OTHERWISE SPECIFIED ON THE PLAN.

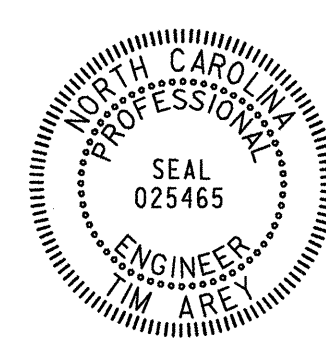

TIP NO. R-2233AB	SHEET NO. PMP-25
APPROVED: <i>Antony</i>	
DATE: 6/29/10	
SEAL	
	

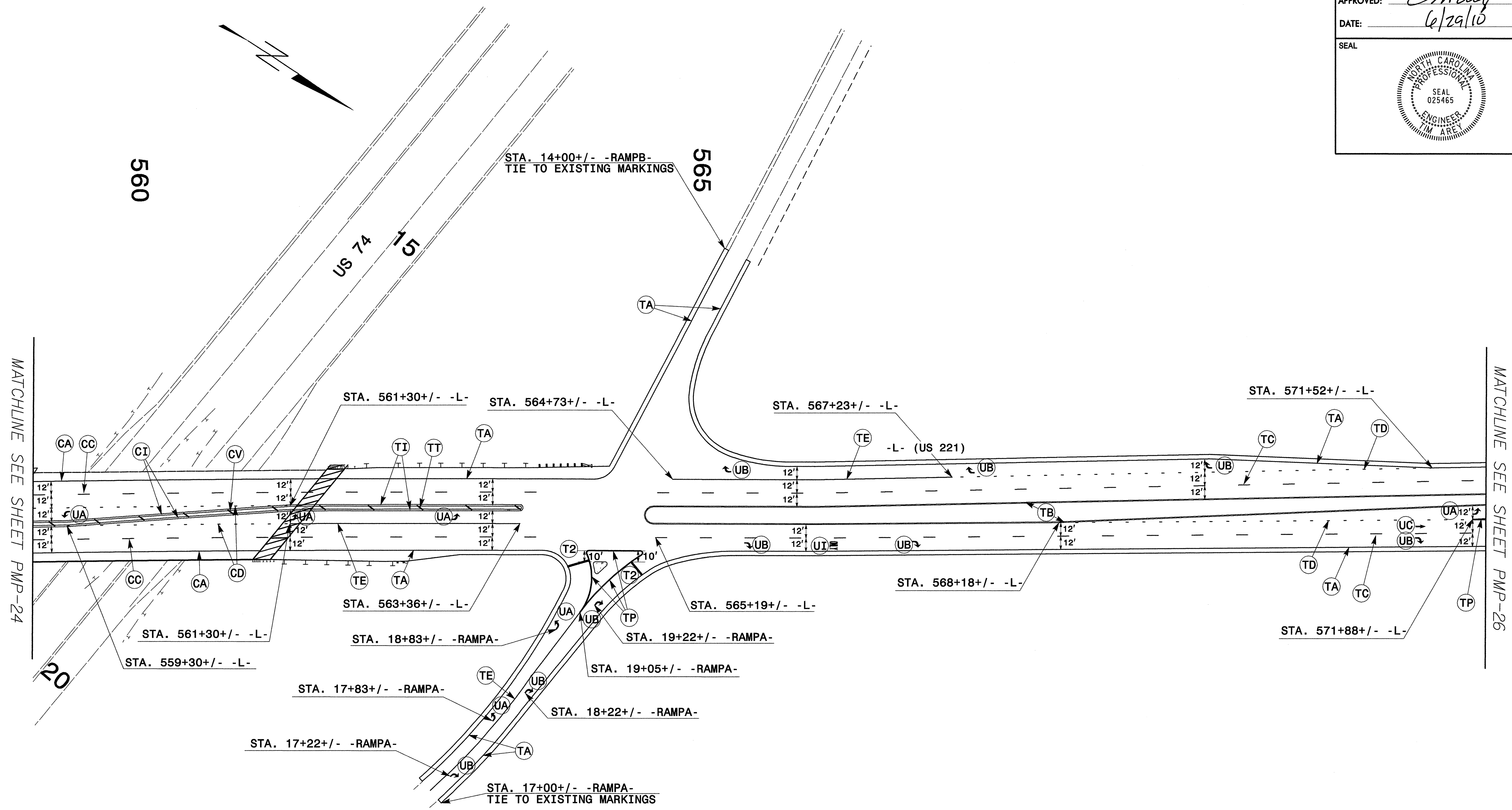

TIP NO. R-2233AB	SHEET NO. PMP-26
APPROVED: <i>[Signature]</i>	
DATE: 6/29/10	
SEAL	
	

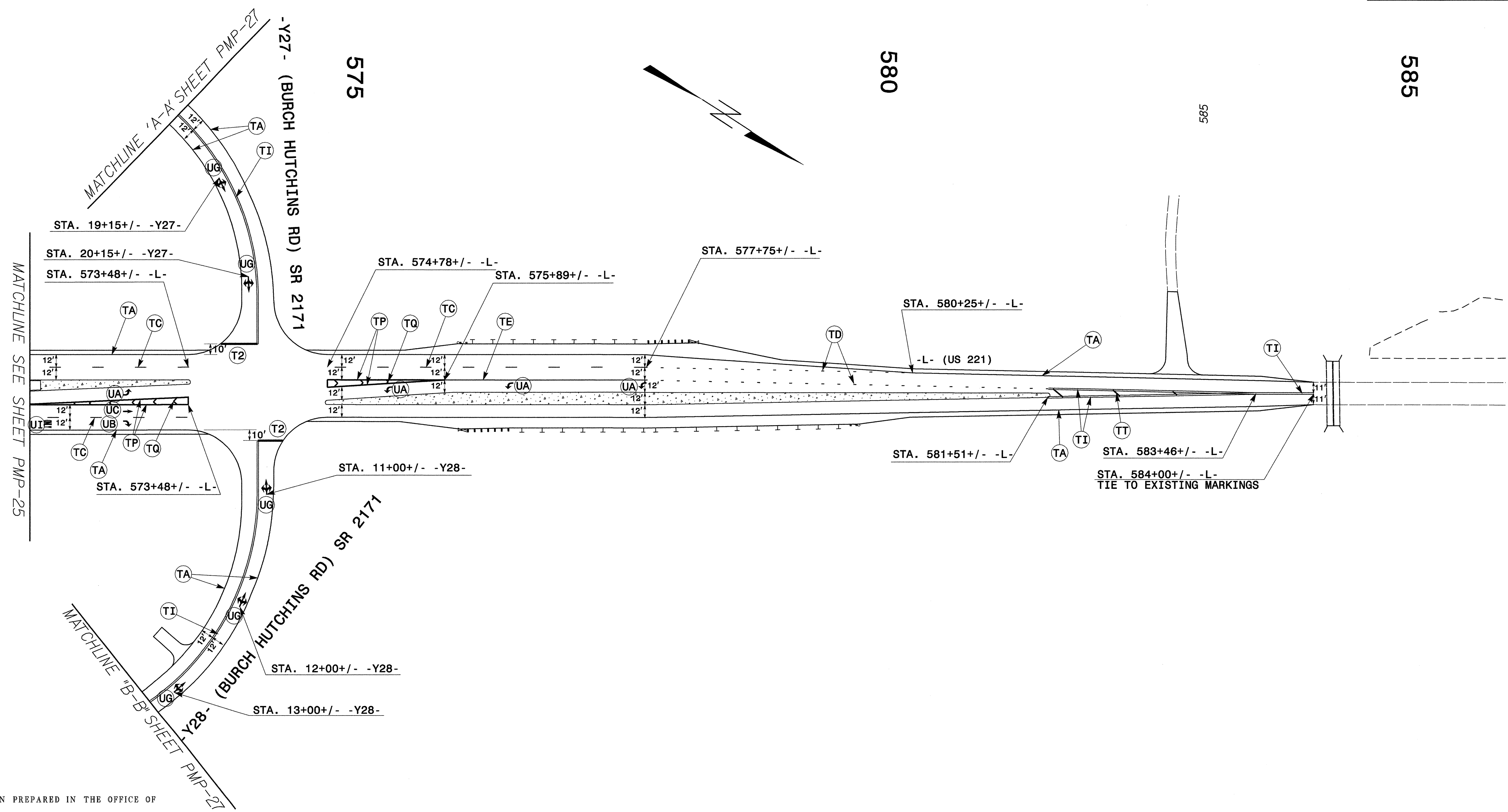

PLAN PREPARED IN THE OFFICE OF  
**PROGRESSIVE**  
 DESIGN GROUP, INC.  
  
 ENGINEERS • CONSULTANTS  
 CHARLOTTE, NC 704.573.5003

**PAVEMENT MARKING DETAIL**

TIP NO. R-2233AB	SHEET NO. PMP-27
APPROVED: <i>Jim Arey</i>	
DATE: 6/29/16	
SEAL	

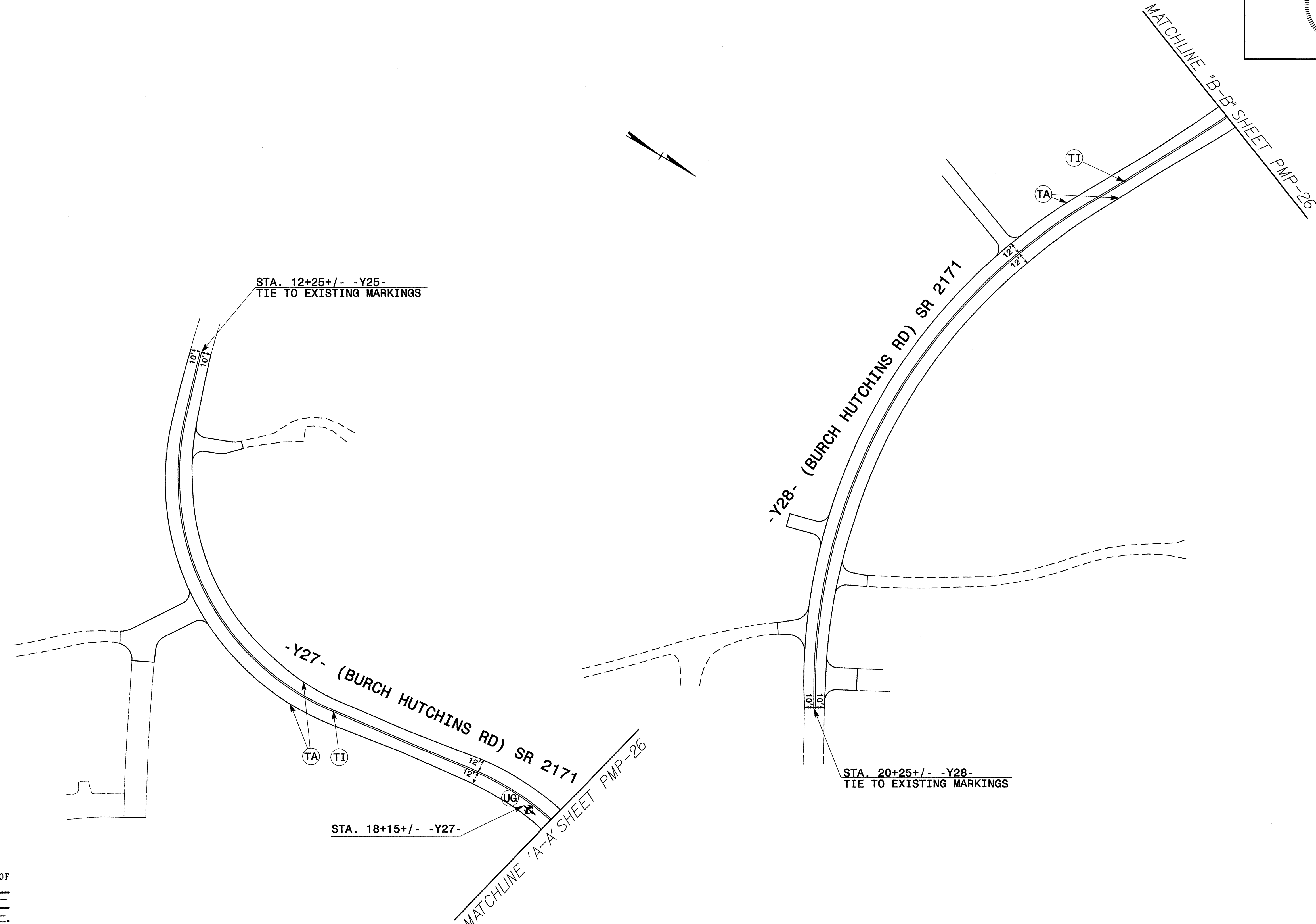

PLAN PREPARED IN THE OFFICE OF  
**PROGRESSIVE**  
 DESIGN GROUP, INC.  
  
 ENGINEERS • CONSULTANTS  
 CHARLOTTE, NC 704.573.5003

**PAVEMENT MARKING DETAIL**