

See Sheet 1-A For Index of Sheets
See Sheet 1-B For Conventional Symbols

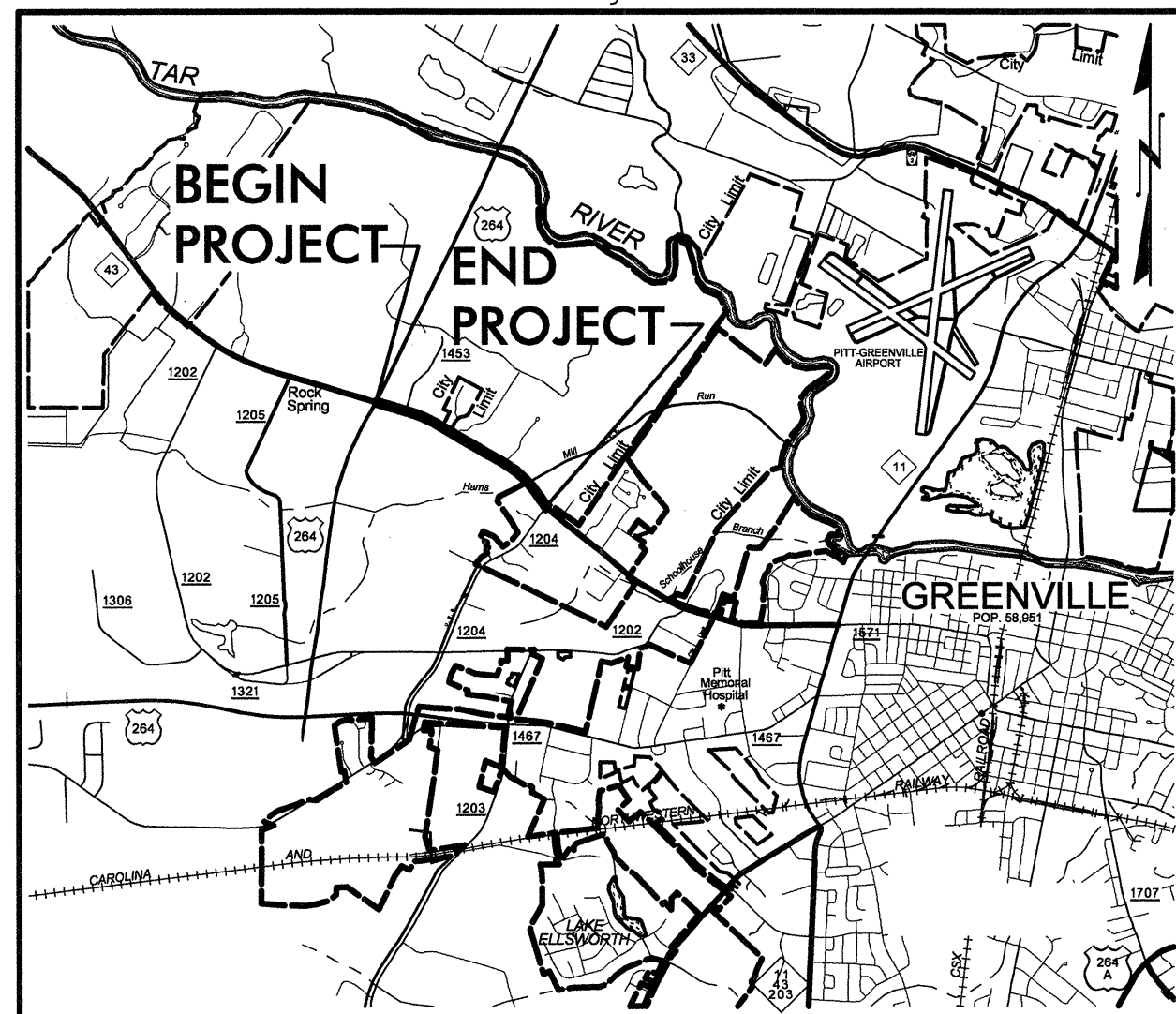

VICINITY MAP

STATE OF NORTH CAROLINA
DIVISION OF HIGHWAYS

PITT COUNTY

LOCATION: GREENVILLE - NC 43 FROM US 264 TO WEST OF SR 1204 (B'S BARBEQUE ROAD)
TYPE OF WORK: GRADING, DRAINAGE, PAVING, WIDENING AND STRUCTURE

STATE	STATE PROJECT REFERENCE NO.	SHEET NO.	TOTAL SHEETS
N.C.	U-5018A	1	
WBS NO.	P.A. PROJ. NO.	DESCRIPTION	
41431.1.2		P.E.	
41431.2.1		RW	
41431.3.2		CONST.	

TIP PROJECT: U-5018A

CONTRACT: C201904

CONTRACT: C201904

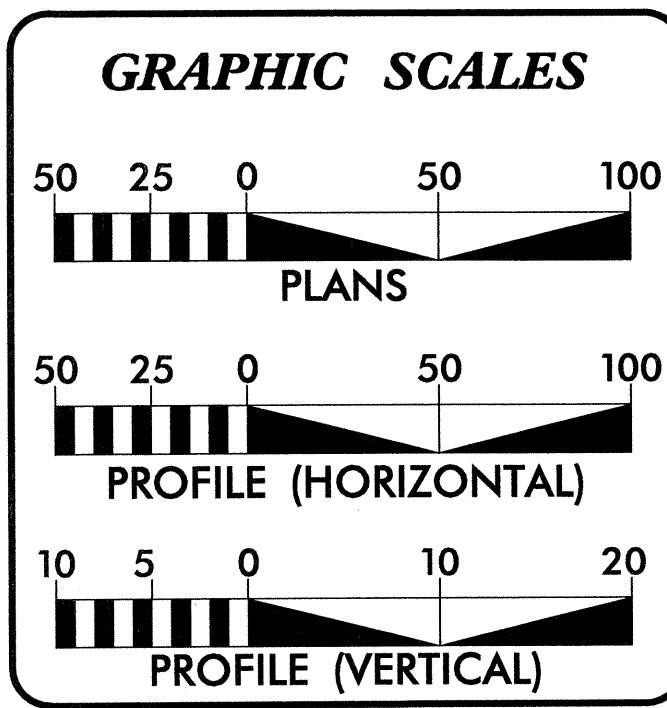
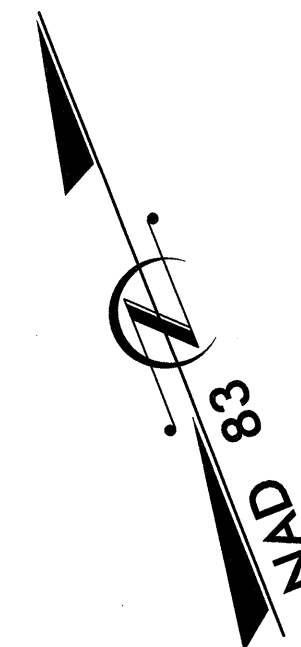
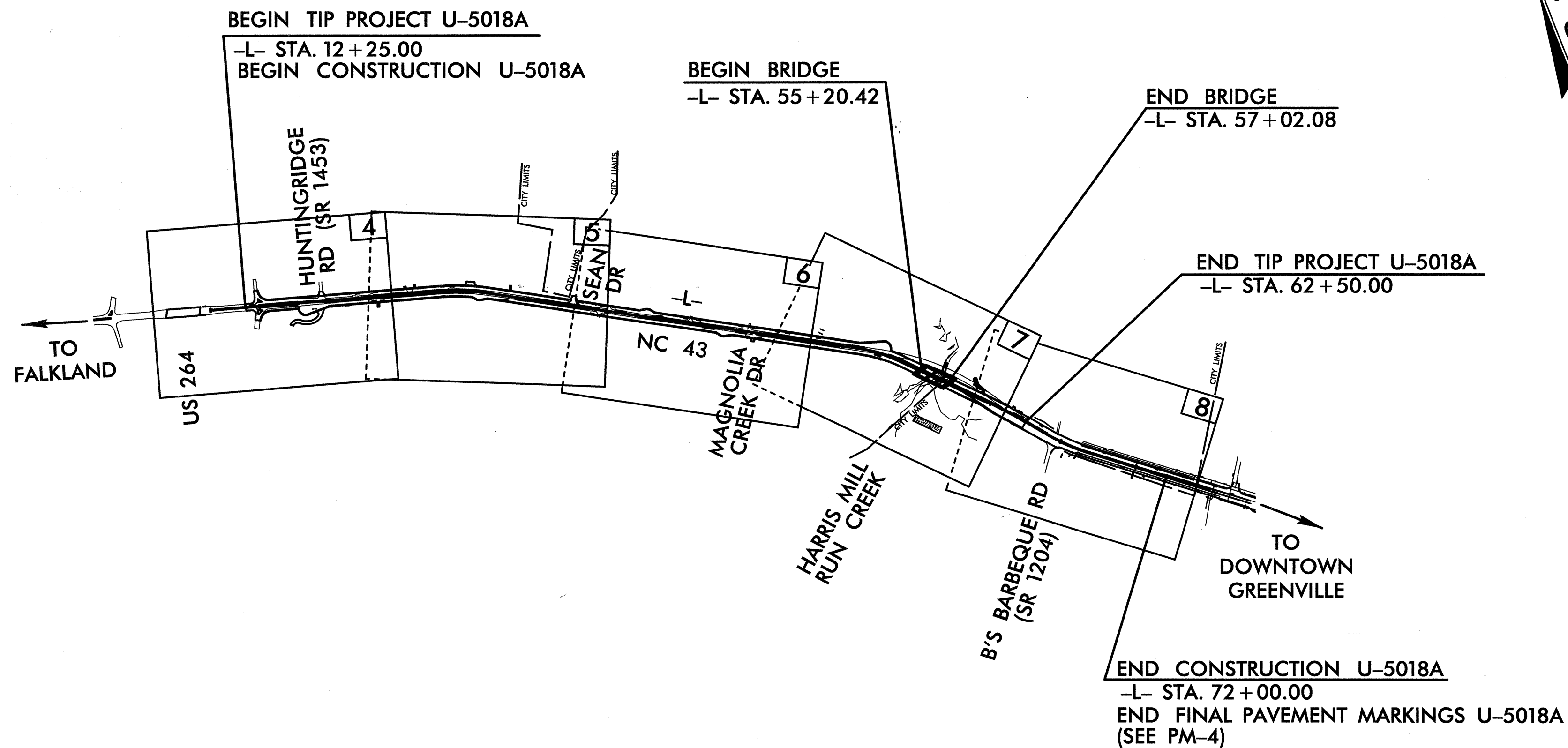

DESIGN DATA

ADT 2010 = 22,550
ADT 2030 = 41,550
DHV = 10 %
D = 50 %
T = 6 % *
V = 50 MPH
(* TTST 2 % + DUAL 4 %)

PROJECT LENGTH

LENGTH ROADWAY TIP PROJECT U-5018A = 0.918 MILES
LENGTH STRUCTURE TIP PROJECT U-5018A = 0.034 MILES
TOTAL LENGTH TIP PROJECT U-5018A = 0.952 MILES

Prepared in the Office of:

MULKEY
ENGINEERS & CONSULTANTS
FOR
NORTH CAROLINA DEPARTMENT OF TRANSPORTATION

2006 STANDARD SPECIFICATIONS

RIGHT OF WAY DATE: N/A

LETTING DATE: AUGUST 17, 2010

NCDOT CONTACT: JOHN ROUSE, PE

STEVE DRUM, PE
PROJECT ENGINEER

KEVIN B. ALFORD, PE
HYDRAULICS ENGINEER

HYDRAULICS ENGINEER

6-3-10

SEAL 31977

KEVIN B. ALFORD
P.E.

ROADWAY DESIGN ENGINEER

6/3/10

SEAL 17265

STEVE ANTHONY DRUM
P.E.

DIVISION OF HIGHWAYS
STATE OF NORTH CAROLINA

STATE HIGHWAY DESIGN ENGINEER

P.E.

6/3/2010 R:\Roadway\Proj\U5018A\U5018A_rdy--tsh.dgn 1:48:43 PM

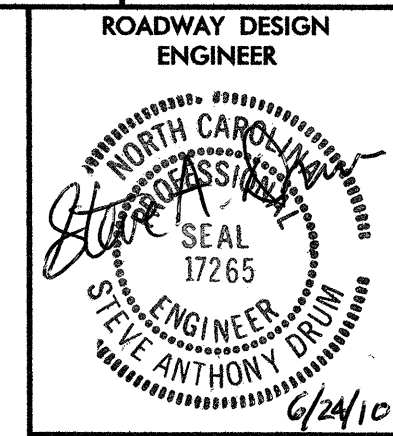

INDEX OF SHEETS

Sheet #	Description
1	Title Sheet
1-A	Index of Sheets, General Notes, and List of Standards
1-B	Conventional Symbols
1-C	Survey Control Sheet
2	Pavement Schedule and Typical Sections
2-A	Detail of Anchorage for Frames
2-B	Detail of Concrete Narrow Drop Inlet
2-C	Detail of Narrow Drop Inlet Frame and Grate and Method for Placement of Drop Inlets in Island
2-D	Detail of Dry Detention Basin, -L- Station 55+43.3
2-E	Detail of Dry Detention Basin, -L- Station 57+34.6
2-F	Detail for Dry Detention Basin Outlet Control Structure
2-G	Notes for Dry Detention Basins
2-H thru 2-I	Detail for Dry Detention Basin Underdrains
2-J	Detail for Dry Detention Basin Trash Racks
2-K thru 2-L	Method of Pipe Installation
2-M	Detail to Convert Existing Catch Basin or Junction Box to Drop Inlet
2-N	Geogrid Reinforced Slope Detail
3	Summary of Quantities
3-A	Summary of Earthwork in Cubic Yards, Guardrail Summary, Summary of Breaking of Pavement, Summary of Pavement Removal, & Subsurface Drain Summary
3-B thru 3-C	List of Pipe, Endwalls, Etc. (For Pipes 48" & Under)
3-D	Parcel Index Sheet
4 thru 8	Plans
9 thru 11	Profile
TCP-1 thru TCP-10	Traffic Control Plans
PM-1 thru PM-4	Pavement Marking Plans
EC-1 thru EC-14	Erosion Control Plans
RF-1 thru RF-3	Reforestation Plans
UC-4 thru UC-8	Utility Construction Plans
UO-1 thru UO-5	Utilities by Others Plans
X-1	Cross-Section Summary Sheet
X-2 thru X-25	Cross-Sections
S-1 thru S-52	Structure Plans

GENERAL NOTES: 2006 SPECIFICATIONS EFFECTIVE: 07-18-06
 REVISED: 07-18-06

GRADING AND SURFACING OR RESURFACING AND WIDENING:
 THE GRADE LINES SHOWN DENOTE THE FINISHED ELEVATION OF THE PROPOSED SURFACING AT GRADE POINTS SHOWN ON THE TYPICAL SECTIONS. WHERE NO GRADE LINES ARE SHOWN, THE PROFILES SHOWN DENOTE THE TOP ELEVATION OF THE EXISTING PAVEMENT ALONG THE CENTER LINE OF SURVEY ON WHICH THE PROPOSED RESURFACING WILL BE PLACED. GRADE LINES MAY BE ADJUSTED BY THE ENGINEER IN ORDER TO SECURE A PROPER TIE-IN.

CLEARING:
 CLEARING ON THIS PROJECT SHALL BE PERFORMED TO THE LIMITS ESTABLISHED BY METHOD III.

SUPERELEVATION:
 ALL CURVES ON THIS PROJECT SHALL BE SUPERELEVATED IN ACCORDANCE WITH STD. NO. 225.04 USING THE RATE OF SUPERELEVATION AND RUNOFF SHOWN ON THE PLANS. SUPERELEVATION IS TO BE REVOLVED ABOUT THE GRADE POINTS SHOWN ON THE TYPICAL SECTIONS.

SHOULDER CONSTRUCTION:
 ASPHALT, EARTH, AND CONCRETE SHOULDER CONSTRUCTION ON THE HIGH SIDE OF SUPERELEVATED CURVES SHALL BE IN ACCORDANCE WITH STD. NO. 560.01.

SIDE ROADS:
 THE CONTRACTOR WILL BE REQUIRED TO DO ALL NECESSARY WORK TO PROVIDE SUITABLE CONNECTIONS WITH ALL ROADS, STREETS, AND DRIVES ENTERING THIS PROJECT. THIS WORK WILL BE PAID FOR AT THE CONTRACT UNIT PRICE FOR THE PARTICULAR ITEMS INVOLVED.

UNDERDRAINS:
 UNDERDRAINS SHALL BE CONSTRUCTED IN ACCORDANCE WITH STD. NO. 815.03 AT LOCATIONS DIRECTED BY THE ENGINEER.

DRIVEWAYS:
 DRIVEWAYS SHALL BE CONSTRUCTED IN ACCORDANCE WITH STD. 848.02 USING 3' RADII OR RADII AS SHOWN ON THE PLANS. LOCATIONS OF DRIVES WILL BE AS SHOWN ON THE PLANS OR AS DIRECTED BY THE ENGINEER.

GUARDRAIL:
 THE GUARDRAIL LOCATIONS SHOWN ON THE PLANS MAY BE ADJUSTED DURING CONSTRUCTION AS DIRECTED BY THE ENGINEER. THE CONTRACTOR SHOULD CONSULT WITH THE ENGINEER PRIOR TO ORDERING GUARDRAIL MATERIAL.

TEMPORARY SHORING:
 SHORING REQUIRED FOR THE MAINTENANCE OF TRAFFIC WILL BE PAID FOR AS "EXTRA WORK" IN ACCORDANCE WITH SECTION 104-7.

END BENTS:
 THE ENGINEER SHALL CHECK THE STRUCTURE END BENT PLANS, DETAILS, AND CROSS-SECTIONS PRIOR TO SETTING OF THE SLOPE STAKES FOR THE EMBANKMENT OR EXCAVATION APPROACHING A BRIDGE.

UTILITIES:
 UTILITY OWNERS ON THIS PROJECT ARE GUC (Electric), GUC (Gas), GUC (Water), SUDDENLINK, CENTURYLINK, PROGRESS ENERGY

ANY RELOCATION OF EXISTING UTILITIES WILL BE ACCOMPLISHED BY OTHERS, EXCEPT AS SHOWN ON THE PLANS.

RIGHT-OF-WAY MARKERS:
 ALL RIGHT-OF-WAY MARKERS ON THIS PROJECT SHALL BE PLACED BY OTHERS.

2006 ROADWAY ENGLISH STANDARD DRAWINGS REV. 01-02-07

The following Roadway Standards as appear in "Roadway Standard Drawings" Highway Design Branch - N. C. Department of Transportation - Raleigh, N. C., Dated July 18, 2006 are applicable to this project and by reference hereby are considered a part of these plans:

STD.NO.	TITLE
DIVISION 2 - EARTHWORK	
200.03	Method of Clearing - Method III
225.02	Guide for Grading Subgrade - Secondary and Local
225.04	Method of Obtaining Superelevation - Two Lane Pavement
DIVISION 3 - PIPE CULVERTS	
310.10	Driveway Pipe Construction
DIVISION 4 - MAJOR STRUCTURES	
422.10	Reinforced Bridge Approach Fills
DIVISION 5 - SUBGRADE, BASES AND SHOULDERS	
560.01	Method of Shoulder Construction - High Side of Superelevated Curve - Method I
DIVISION 6 - ASPHALT BASES AND PAVEMENTS	
654.01	Pavement Repairs
DIVISION 8 - INCIDENTALS	
815.03	Pipe Underdrain and Blind Drain
840.00	Concrete Base Pad for Drainage Structures
840.01	Brick Catch Basin - 12" thru 54" Pipe
840.02	Concrete Catch Basin - 12" thru 54" Pipe
840.03	Frame, Grates and Hood - for Use on Standard Catch Basin
840.14	Concrete Drop Inlet - 12" thru 30" Pipe
840.15	Brick Drop Inlet - 12" thru 30" Pipe
840.16	Drop Inlet Frame and Grates - for use with Std. Dwg 840.14 and 840.15
840.18	Concrete Grated Drop Inlet Type 'B' - 12" thru 36" Pipe
840.24	Frames and Narrow Slot Sag Grates
840.27	Brick Grated Drop Inlet Type 'B' - 12" thru 36" Pipe
840.29	Frames & Narrow Slot Flat Grates
840.31	Concrete Junction Box - 12" thru 66" Pipe
840.32	Brick Junction Box - 12" thru 66" Pipe
840.34	Traffic Bearing Junction Box - for Use with Pipes 42" and Under
840.35	Traffic Bearing Grate Drop Inlet - for Cast Iron Double Frame and Grates
840.45	Precast Drainage Structure
840.46	Traffic Bearing Precast Drainage Structure
840.54	Manhole Frame and Cover
840.66	Drainage Structure Steps
840.72	Pipe Collar
846.01	Concrete Curb, Gutter and Curb & Gutter
846.02	Drop Inlet Installation in Expressway Gutter
848.02	Driveway Turnout - Radius Type
852.01	Concrete Islands
852.04	Method for Placement of Drop Inlets in Grassed Median - Using 1'-6" Curb and Gutter
852.06	Method for Placement of Drop Inlets in Concrete Islands
862.01	Guardrail Placement
862.02	Guardrail Installation
862.03	Structure Anchor Units
862.04	Anchoring End of Guardrail - B-77 and B-83 Anchor Units
876.02	Guide for Rip Rap at Pipe Outlets
876.04	Drainage Ditches with Class 'B' Rip Rap

Note: Not to Scale

*S.U.E. = Subsurface Utility Engineering

STATE OF NORTH CAROLINA
DIVISION OF HIGHWAYS

CONVENTIONAL PLAN SHEET SYMBOLS

BOUNDARIES AND PROPERTY:

State Line	_____
County Line	_____
Township Line	_____
City Line	_____
Reservation Line	_____
Property Line	_____
Existing Iron Pin	○ EIP
Property Corner	_____
Property Monument	□ EDM
Parcel/Sequence Number	123
Existing Fence Line	-x-x-x-
Proposed Woven Wire Fence	○
Proposed Chain Link Fence	□
Proposed Barbed Wire Fence	◇
Existing Wetland Boundary	-WLB-
Proposed Wetland Boundary	-WLB-
Existing Endangered Animal Boundary	-EAB-
Existing Endangered Plant Boundary	-EPB-

BUILDINGS AND OTHER CULTURE:

Gas Pump Vent or UG Tank Cap	○
Sign	○
Well	○
Small Mine	⊗
Foundation	□
Area Outline	□
Cemetery	⊕
Building	□
School	□
Church	⊕
Dam	□

HYDROLOGY:

Stream or Body of Water	_____
Hydro, Pool or Reservoir	□
Jurisdictional Stream	-JS-
Buffer Zone 1	-BZ 1-
Buffer Zone 2	-BZ 2-
Flow Arrow	←
Disappearing Stream	→
Spring	○
Wetland	⊗
Proposed Lateral, Tail, Head Ditch	_____
False Sump	□

RAILROADS:

Standard Gauge	_____
RR Signal Milepost	○
Switch	□
RR Abandoned	_____
RR Dismantled	_____

RIGHT OF WAY:

Baseline Control Point	◆
Existing Right of Way Marker	△
Existing Right of Way Line	_____
Proposed Right of Way Line	_____
Proposed Right of Way Line with Iron Pin and Cap Marker	_____
Proposed Right of Way Line with Concrete or Granite Marker	_____
Existing Control of Access	⊗
Proposed Control of Access	⊗
Existing Easement Line	-E-
Proposed Temporary Construction Easement	-E-
Proposed Temporary Drainage Easement	-TDE-
Proposed Permanent Drainage Easement	-PDE-
Proposed Permanent Drainage / Utility Easement	-DUE-
Proposed Permanent Utility Easement	-PUE-
Proposed Temporary Utility Easement	-TUE-
Proposed Permanent Easement with Iron Pin and Cap Marker	◆

ROADS AND RELATED FEATURES:

Existing Edge of Pavement	_____
Existing Curb	_____
Proposed Slope Stakes Cut	-C-
Proposed Slope Stakes Fill	-F-
Proposed Wheel Chair Ramp	WCR
Existing Metal Guardrail	_____
Proposed Guardrail	_____
Existing Cable Guiderail	_____
Proposed Cable Guiderail	_____
Equality Symbol	⊕
Pavement Removal	⊗

VEGETATION:

Single Tree	⊗
Single Shrub	⊗
Hedge	_____
Woods Line	_____
Orchard	_____
Vineyard	_____

EXISTING STRUCTURES:

MAJOR:	
Bridge, Tunnel or Box Culvert	CONC
Bridge Wing Wall, Head Wall and End Wall	CONC WW
MINOR:	
Head and End Wall	CONC HW
Pipe Culvert	_____
Footbridge	_____
Drainage Box: Catch Basin, DI or JB	CB
Paved Ditch Gutter	_____
Storm Sewer Manhole	⊗
Storm Sewer	-S-

UTILITIES:

POWER:	
Existing Power Pole	●
Proposed Power Pole	○
Existing Joint Use Pole	●
Proposed Joint Use Pole	○
Power Manhole	⊗
Power Line Tower	⊗
Power Transformer	⊗
UG Power Cable Hand Hole	⊗
H-Frame Pole	●
Recorded UG Power Line	-P-
Designated UG Power Line (S.U.E.*)	-P-

TELEPHONE:

Existing Telephone Pole	●
Proposed Telephone Pole	○
Telephone Manhole	⊗
Telephone Booth	⊗
Telephone Pedestal	⊗
Telephone Cell Tower	⊗
UG Telephone Cable Hand Hole	⊗
Recorded UG Telephone Cable	-T-
Designated UG Telephone Cable (S.U.E.*)	-T-
Recorded UG Telephone Conduit	-TC-
Designated UG Telephone Conduit (S.U.E.*)	-TC-
Recorded UG Fiber Optics Cable	-T FO-
Designated UG Fiber Optics Cable (S.U.E.*)	-T FO-

WATER:

Water Manhole	⊗
Water Meter	○
Water Valve	⊗
Water Hydrant	⊗
Recorded UG Water Line	-W-
Designated UG Water Line (S.U.E.*)	-W-
Above Ground Water Line	-A/G Water-

TV:

TV Satellite Dish	⊗
TV Pedestal	⊗
TV Tower	⊗
UG TV Cable Hand Hole	⊗
Recorded UG TV Cable	-TV-
Designated UG TV Cable (S.U.E.*)	-TV-
Recorded UG Fiber Optic Cable	-TV FO-
Designated UG Fiber Optic Cable (S.U.E.*)	-TV FO-

GAS:

Gas Valve	◇
Gas Meter	⊗
Recorded UG Gas Line	-G-
Designated UG Gas Line (S.U.E.*)	-G-
Above Ground Gas Line	-A/G Gas-

SANITARY SEWER:

Sanitary Sewer Manhole	⊗
Sanitary Sewer Cleanout	⊗
UG Sanitary Sewer Line	-SS-
Above Ground Sanitary Sewer	-A/G Sanitary Sewer-
Recorded SS Forced Main Line	-FSS-
Designated SS Forced Main Line (S.U.E.*)	-FSS-

MISCELLANEOUS:

Utility Pole	●
Utility Pole with Base	□
Utility Located Object	○
Utility Traffic Signal Box	⊗
Utility Unknown UG Line	-UTIL-
UG Tank; Water, Gas, Oil	□
A/G Tank; Water, Gas, Oil	□
UG Test Hole (S.U.E.*)	⊗
Abandoned According to Utility Records	AATUR
End of Information	E.O.I.

STATE OF NORTH CAROLINA
DIVISION OF HIGHWAYS

PITT COUNTY

LOCATION: GREENVILLE - NC 43 FROM US 264 TO WEST OF SR 1204 (B'S BARBEQUE ROAD)
TYPE OF WORK: GRADING, PAVING, DRAINAGE, AND STRUCTURE

STATE	STATE PROJECT REFERENCE NO.	SHEET NO.	TOTAL SHEETS
N.C.	U-5018A	1C	
WBS NO.	F.A. PROJ. NO.	DESCRIPTION	
41431.1.2		P.E.	
41431.2.1		RW	
41431.3.2		CONST.	

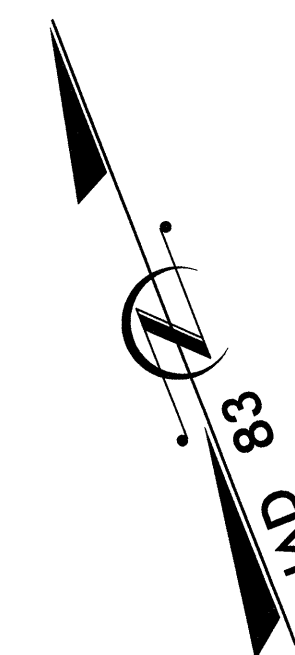

TIP PROJECT: U-5018A

CONTRACT: C201904

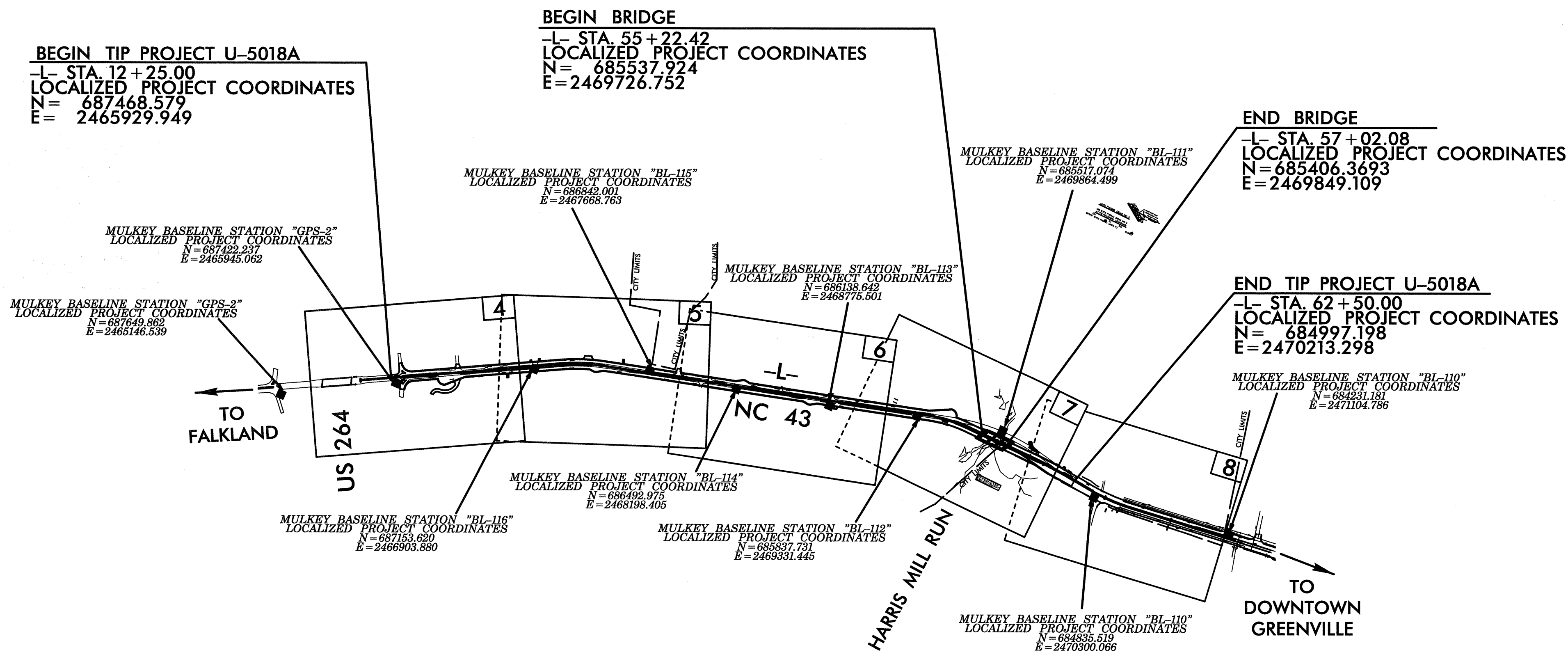

DATUM DESCRIPTION
THE LOCALIZED COORDINATE SYSTEM DEVELOPED FOR THIS PROJECT IS BASED ON THE STATE PLANE COORDINATES ESTABLISHED BY OTHERS FOR MONUMENT "GPS-3"
WITH NAD 1983/95 STATE PLANE GRID COORDINATES OF
NORTHING: 683709.837(±ft) EASTING: 2471651.366(±ft)
THE AVERAGE COMBINED GRID FACTOR USED ON THIS PROJECT (GROUND TO GRID) IS: 0.99989593
THE N.C. LAMBERT GRID BEARING AND LOCALIZED HORIZONTAL GROUND DISTANCE FROM "GPS-3" TO -L- STATION IS
ALL LINEAR DIMENSIONS ARE LOCALIZED HORIZONTAL DISTANCES
VERTICAL DATUM USED IS NAVD 88

INDICATES CONTROL MONUMENTS USED OR SET FOR HORIZONTAL PROJECT CONTROL BY MULKEY ENGINEERS AND CONSULTANTS

PROJECT CONTROL ESTABLISHED UTILIZING CONVENTIONAL SURVEY

NOTE: DRAWING NOT TO SCALE

6/3/2010 9:17 PM G:\Project\2006\246.03 (NC 43)\Roadway\Project\U5018A\U5018A_Is-controlsheet_090223.dgn

PAVEMENT SCHEDULE (FINAL PAVEMENT DESIGN)	
C1	PROP. APPROX. 3" ASPHALT CONCRETE SURFACE COURSE, TYPE S9.5C, AT AN AVERAGE RATE OF 168 LBS. PER SQ. YD. IN EACH OF TWO LAYERS.
C2	PROP. VAR. DEPTH ASPHALT CONCRETE SURFACE COURSE, TYPE S9.5C, AT AN AVERAGE RATE OF 112 LBS. PER SQ. YD. PER. 1" DEPTH TO BE PLACED IN LAYERS NOT TO EXCEED 2".
D1	PROP. APPROX. 4" ASPHALT CONCRETE INTERMEDIATE COURSE, TYPE I19.0C, AT AN AVERAGE RATE OF 456 LBS. PER SQ. YD.
E1	PROP. APPROX. 7" ASPHALT CONCRETE BASE COURSE, TYPE B25.0C, AT AN AVERAGE RATE OF 399 LBS. PER SQ. YD. IN EACH OF TWO LAYERS.
R1	2'-6" CONCRETE CURB AND GUTTER.
R2	1'-6" CONCRETE CURB AND GUTTER.
R3	CONCRETE EXPRESSWAY GUTTER.
R4	5" MONOLITHIC CONCRETE ISLAND (KEYED IN).
R5	MODIFIED MONOLITHIC CONCRETE ISLAND (KEYED IN). (SEE ISLAND DETAIL)
T	EARTH MATERIAL.
W	VARIABLE DEPTH ASPHALT PAVEMENT (SEE STANDARD WEDGING DETAIL)

NOTE: PAVEMENT EDGE SLOPES ARE 1:1 UNLESS SHOWN OTHERWISE.

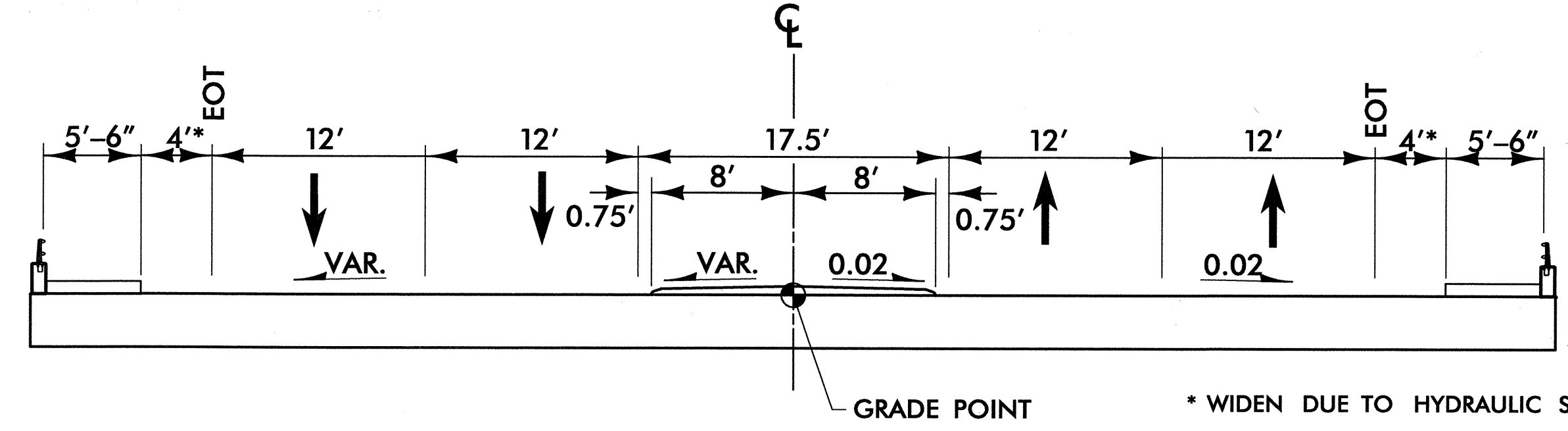

TYPICAL SECTION ON STRUCTURE

-L- STA. 55+20.42 TO STA. 57+02.08

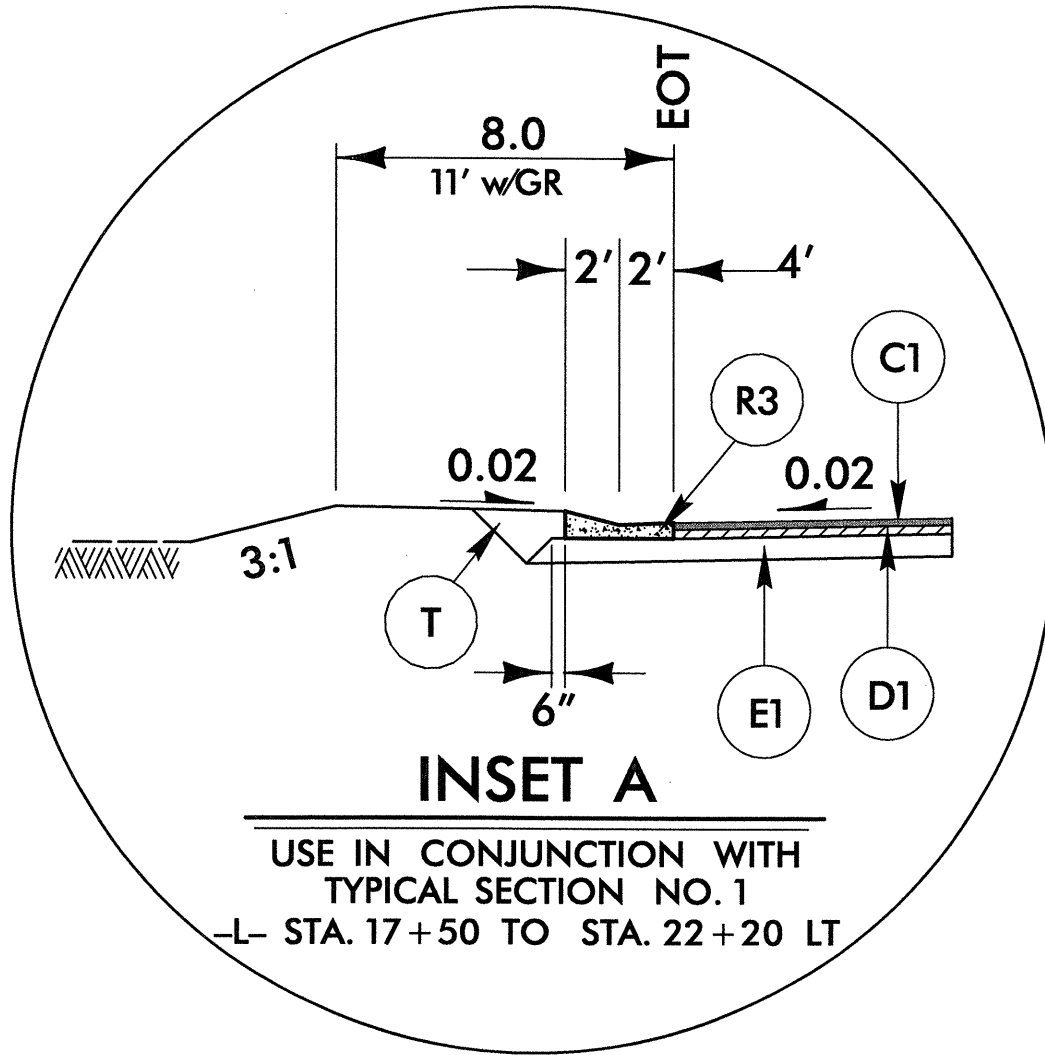

INSET A

USE IN CONJUNCTION WITH TYPICAL SECTION NO. 1
-L- STA. 17+50 TO STA. 22+20 LT

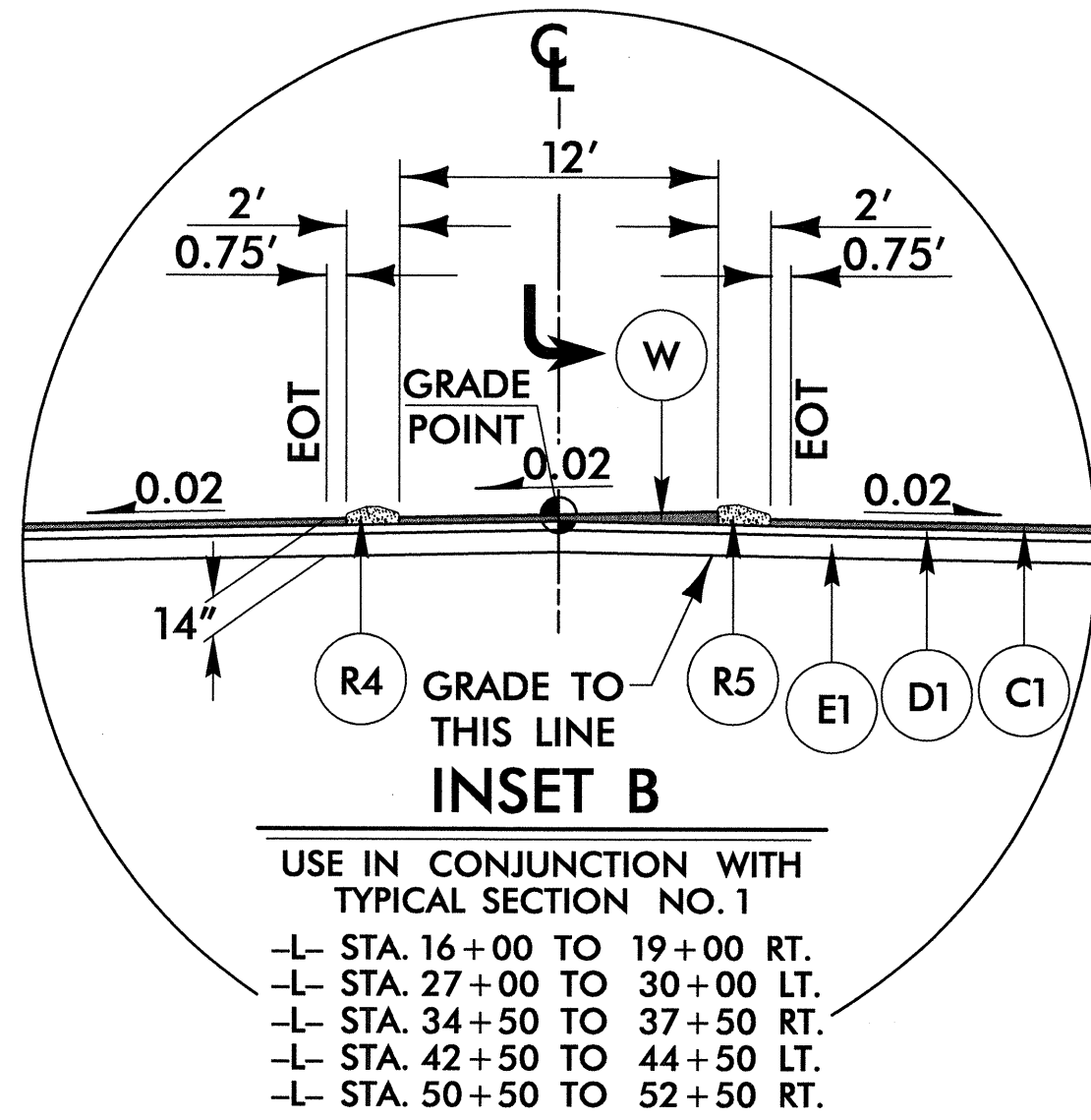

INSET B

USE IN CONJUNCTION WITH TYPICAL SECTION NO. 1
-L- STA. 16+00 TO 19+00 RT.
-L- STA. 27+00 TO 30+00 LT.
-L- STA. 34+50 TO 37+50 RT.
-L- STA. 42+50 TO 44+50 LT.
-L- STA. 50+50 TO 52+50 RT.

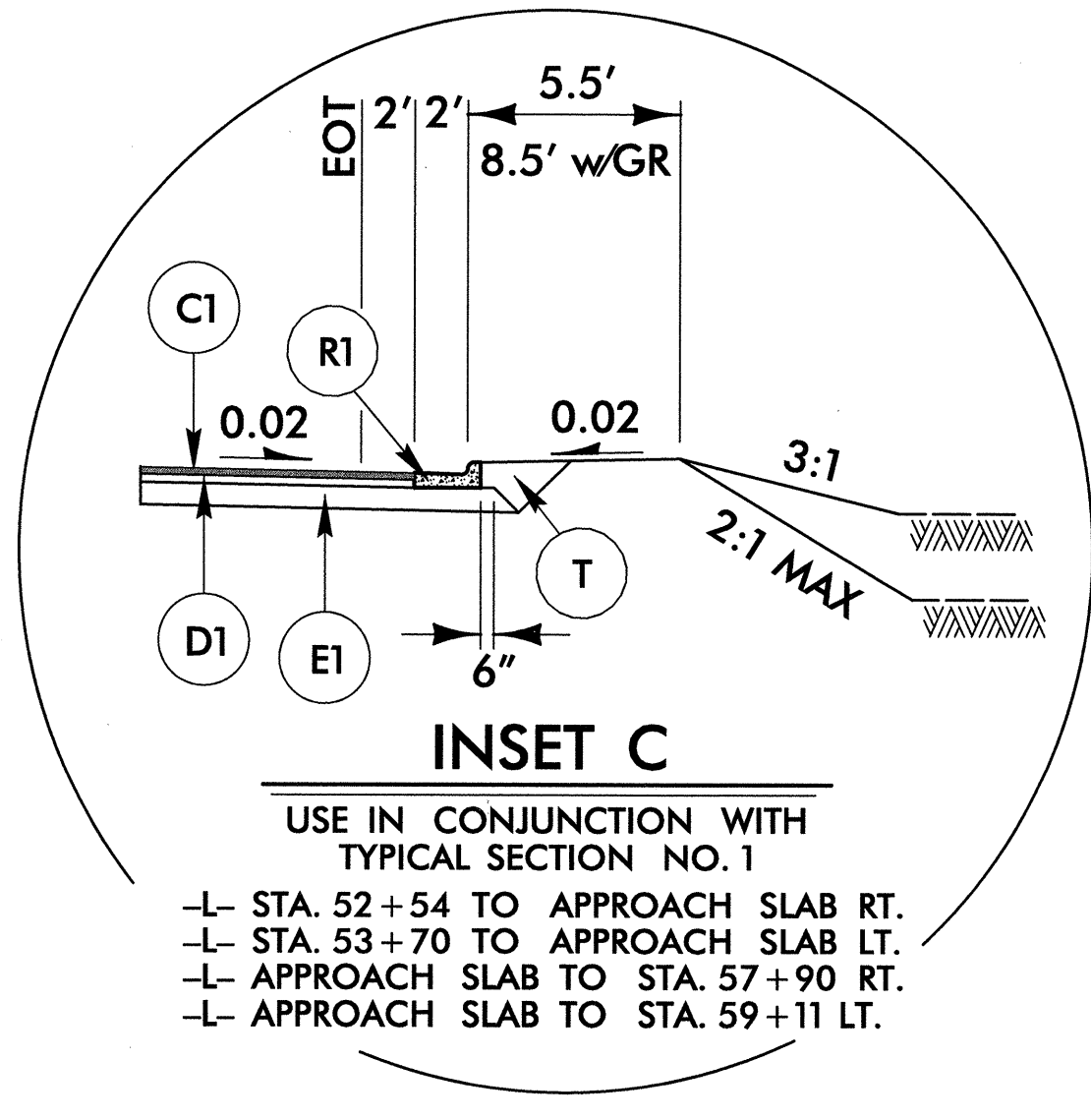

INSET C

USE IN CONJUNCTION WITH TYPICAL SECTION NO. 1
-L- STA. 52+54 TO APPROACH SLAB RT.
-L- STA. 53+70 TO APPROACH SLAB LT.
-L- APPROACH SLAB TO STA. 57+90 RT.
-L- APPROACH SLAB TO STA. 59+11 LT.

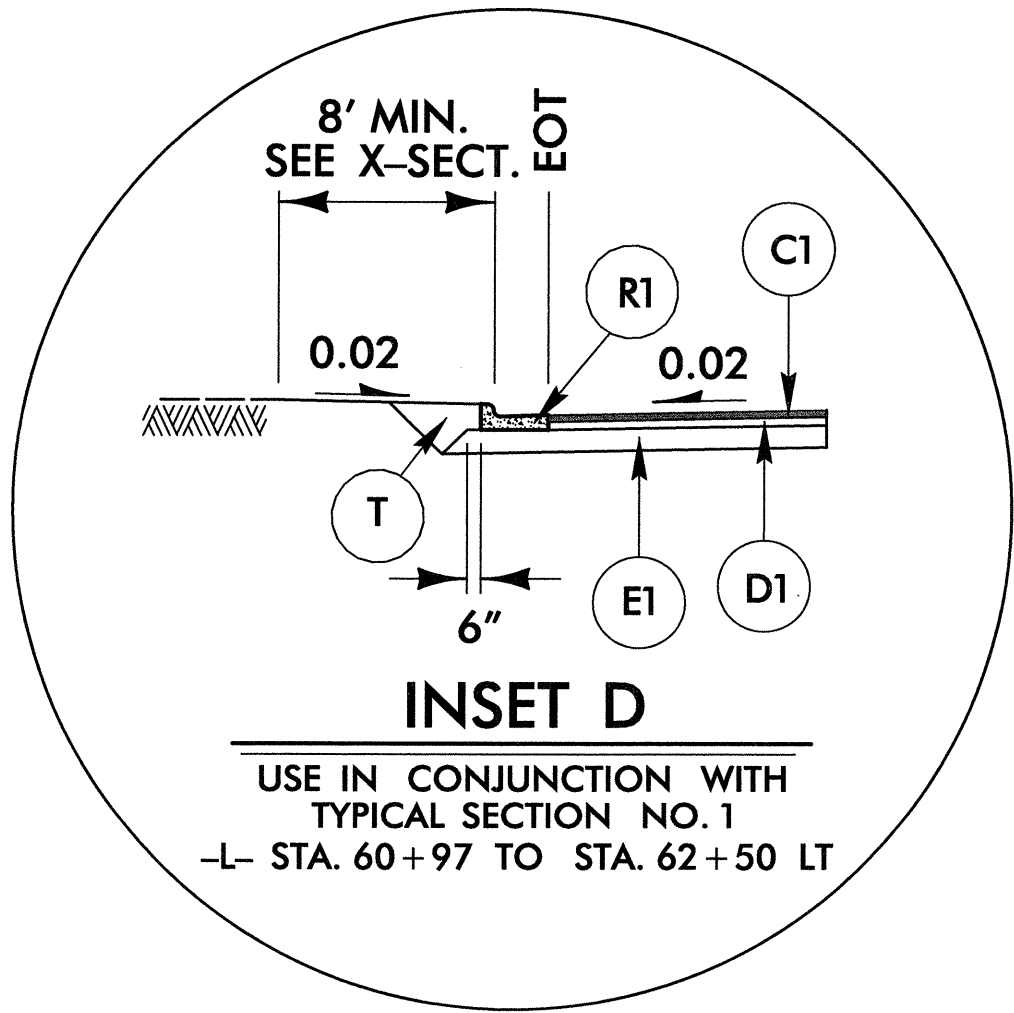

INSET D

USE IN CONJUNCTION WITH TYPICAL SECTION NO. 1
-L- STA. 60+97 TO STA. 62+50 LT

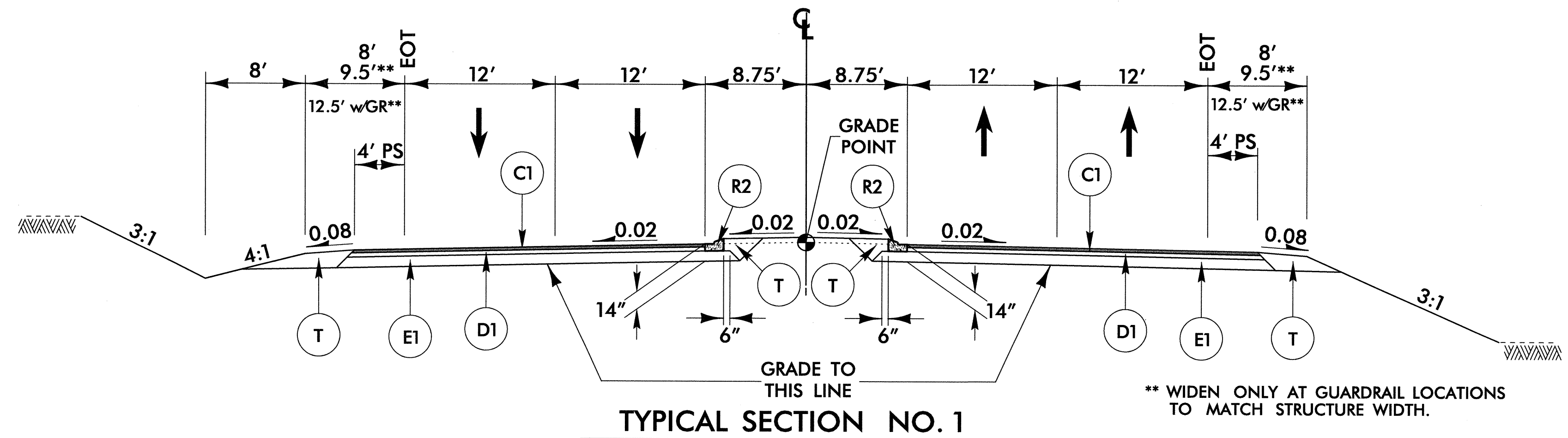

TYPICAL SECTION NO. 1

USE TYPICAL SECTION NO. 1 AT THE FOLLOWING LOCATIONS
-L- STA. 13+00.00 TO STA. 55+20.42 (BEGIN BRIDGE)
-L- STA. 57+02.08 (END BRIDGE) TO STA. 62+50.00
TRANSITION FROM EXISTING TO TYPICAL NO. 1
-L- STA. 12+25.00 TO STA. 13+00.00

** WIDEN ONLY AT GUARDRAIL LOCATIONS TO MATCH STRUCTURE WIDTH.

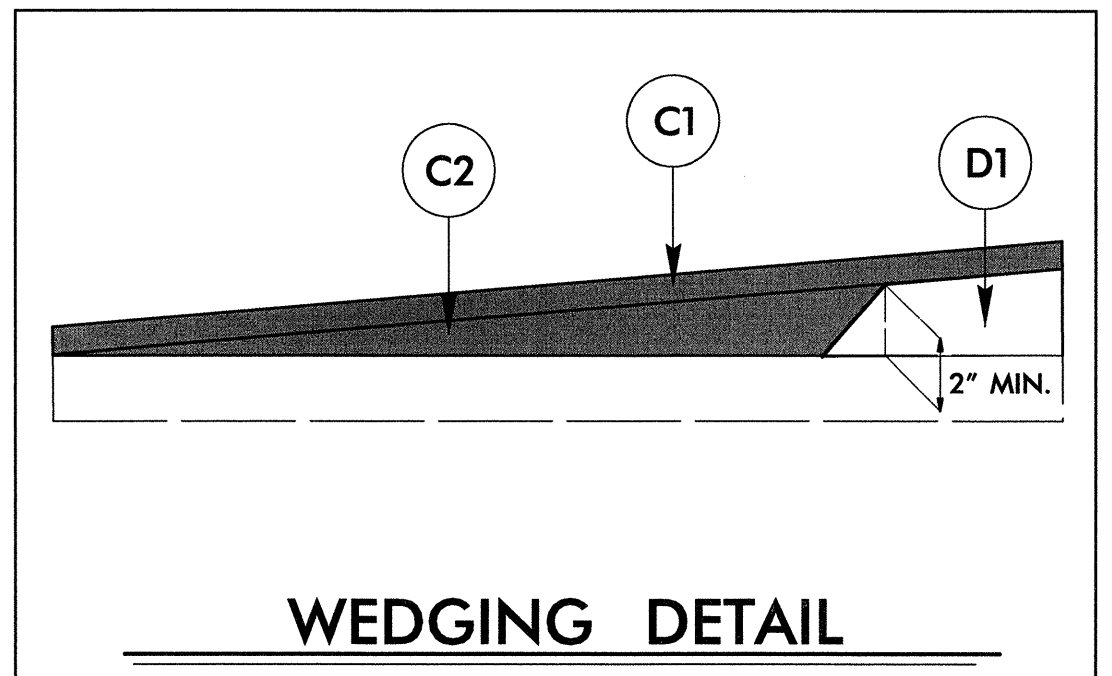

WEDGING DETAIL

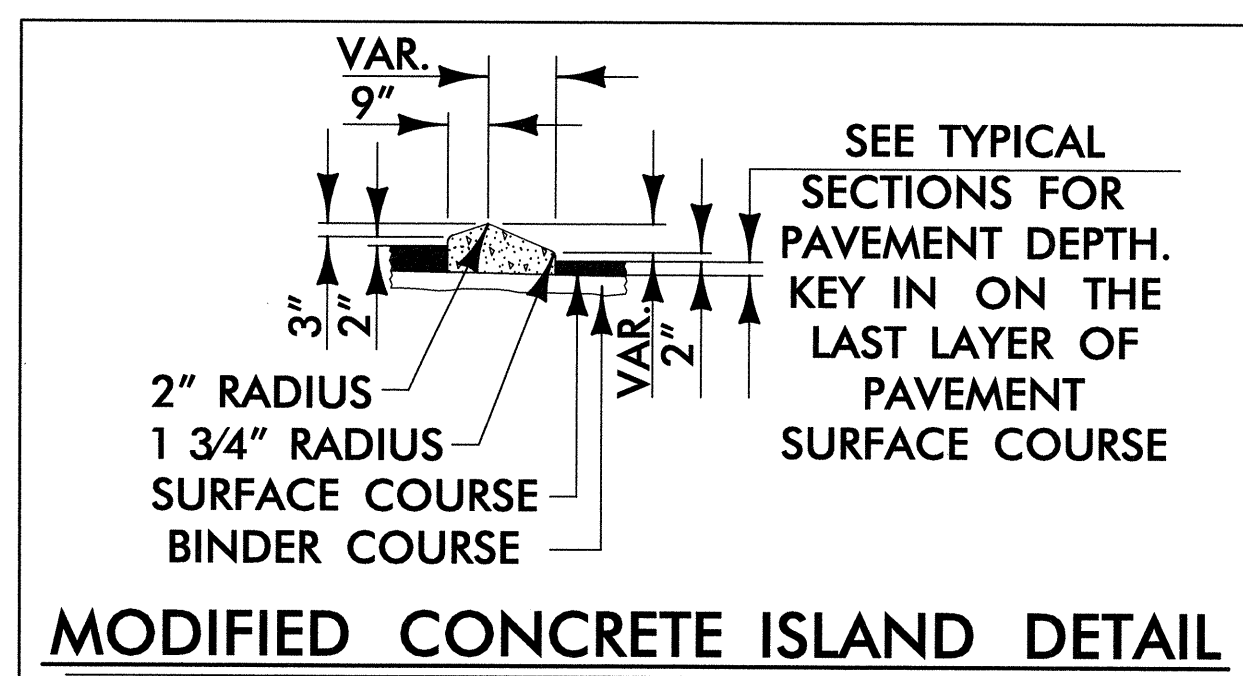

MODIFIED CONCRETE ISLAND DETAIL

6/3/2010 9:45:18 PM G:\projects\2006\246\03 (NC 43)\Roadway\Proj\U5018A\U5018A_rdy_fyp.dgn

STATE OF NORTH CAROLINA
DEPT. OF TRANSPORTATION
DIVISION OF HIGHWAYS
RALEIGH, N.C.

ENGLISH DETAIL DRAWING FOR
ANCHORAGE FOR FRAMES
BRICK/CONCRETE/PRECAST CONCRETE

SHEET 1 OF 1
840D25

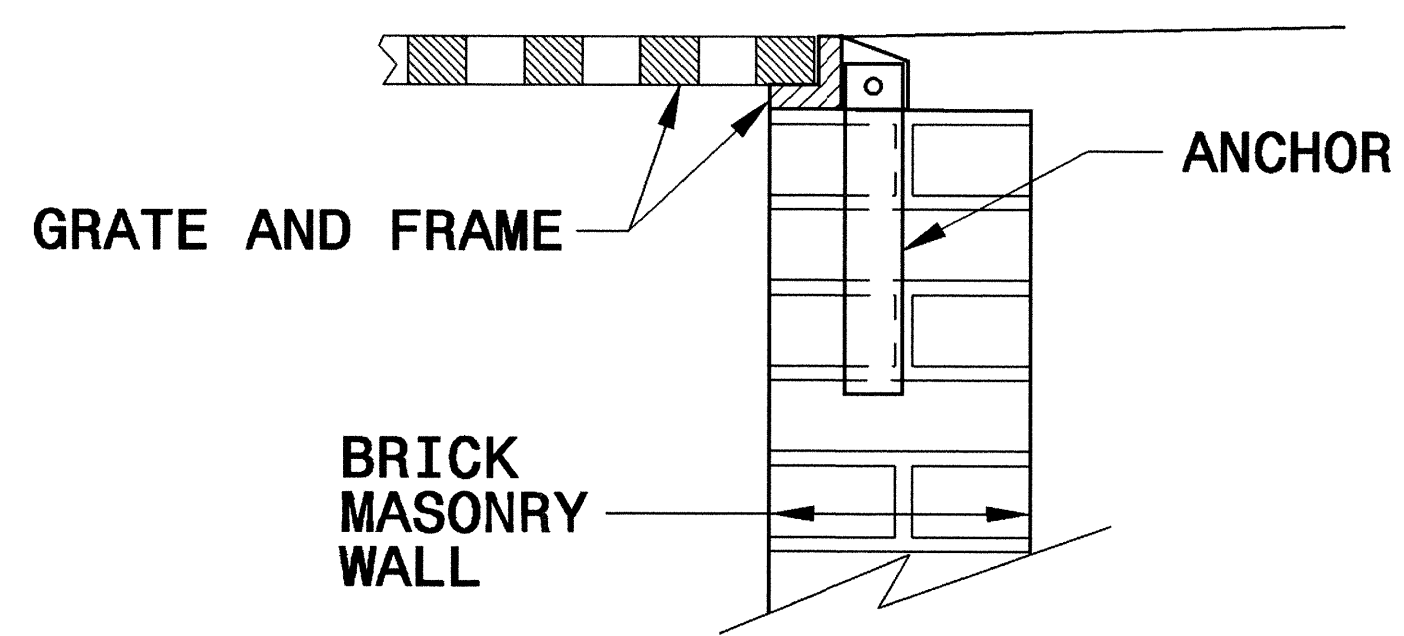

BRICK MASONRY CONSTRUCTION

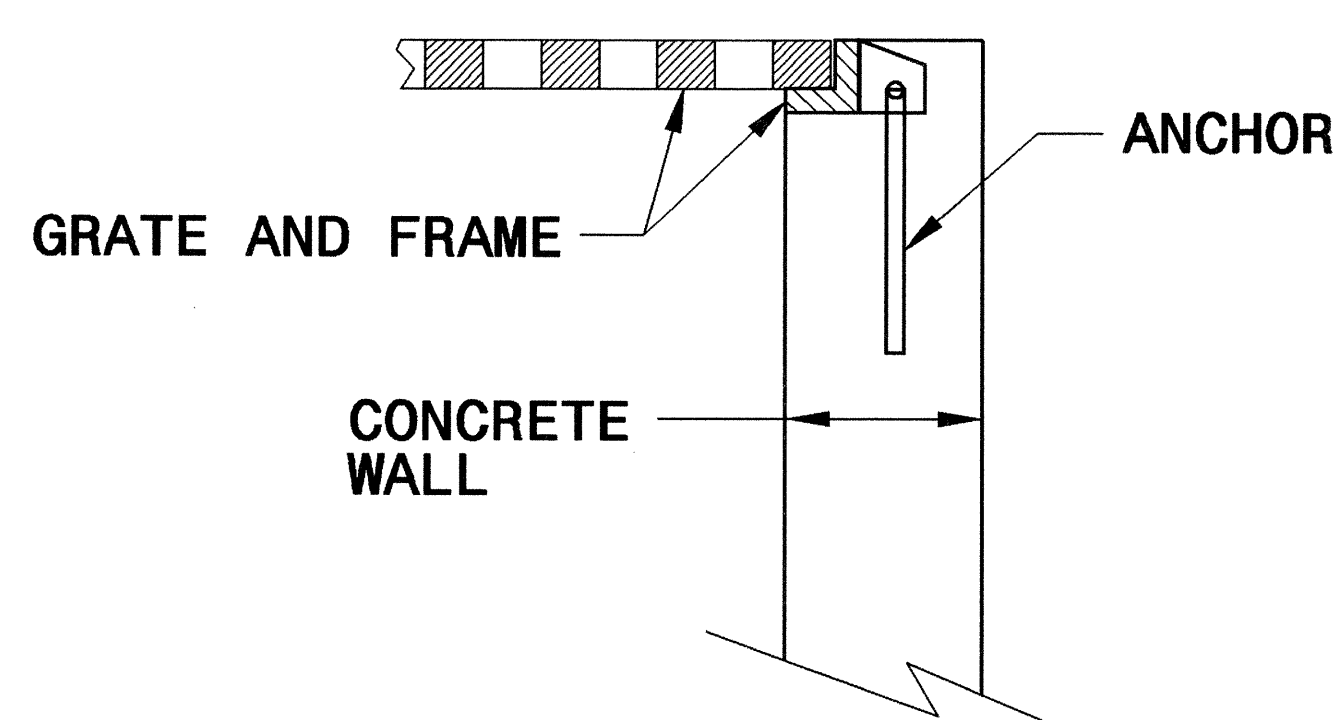

CONCRETE CONSTRUCTION

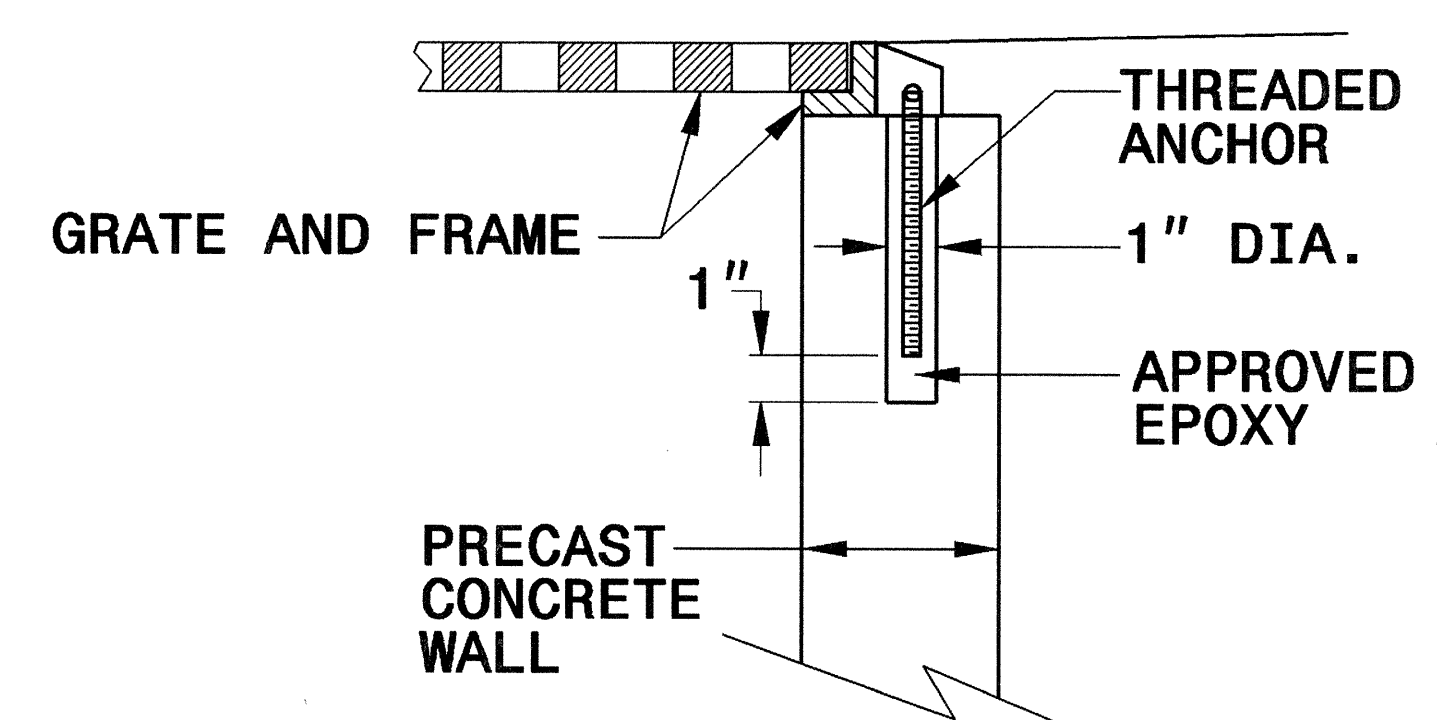

PRECAST CONCRETE CONSTRUCTION

DETAIL SHOWING ANCHORAGE OF FRAME FOR GRATED DROP INLET

NOTE:
CONSTRUCT GRATED DROP INLET TO COINCIDE WITH NORMAL OR SUPERELEVATED SHOULDER OR PAVEMENT SLOPE.

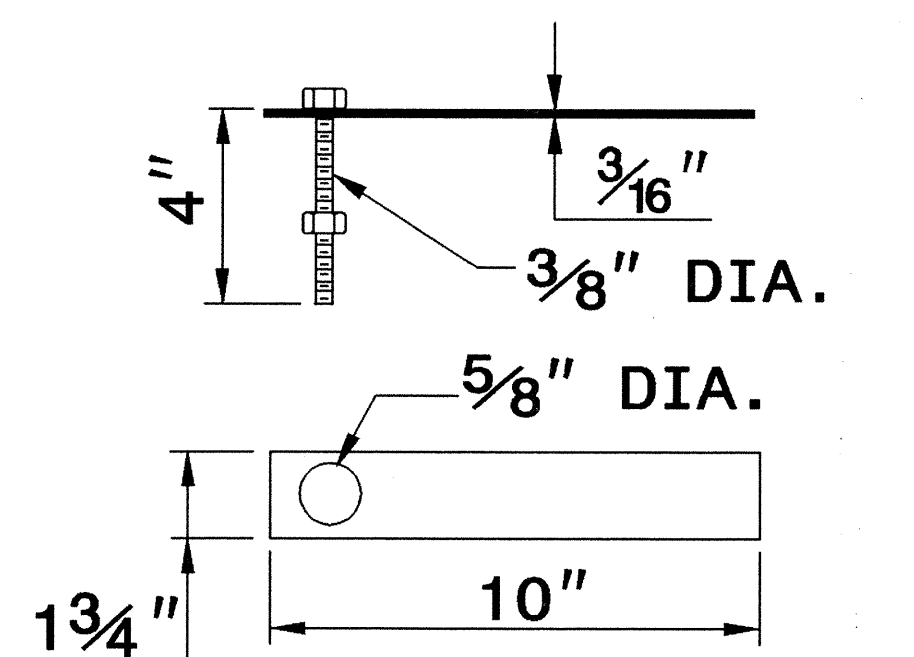

MASONRY ANCHOR
3/8" DIA. BOLT WITH PLATE

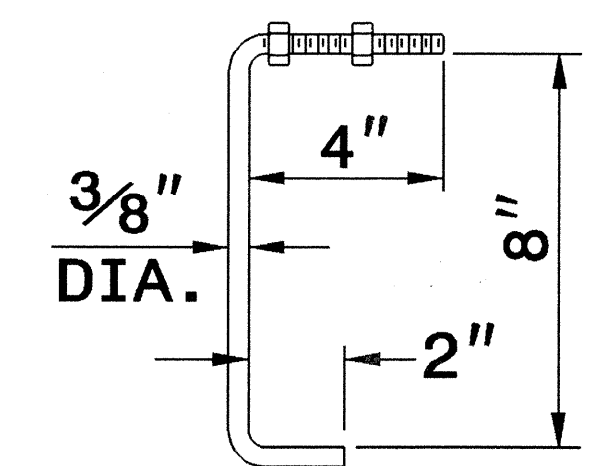

CONCRETE ANCHOR
3/8" DIA. BENT BAR

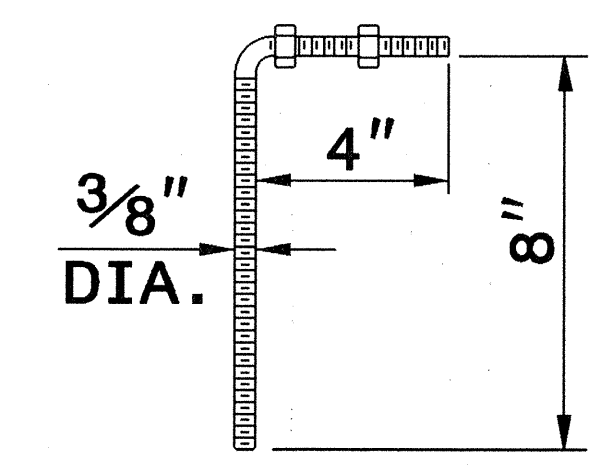

PRECAST CONCRETE ANCHOR
3/8" DIA. BENT BAR

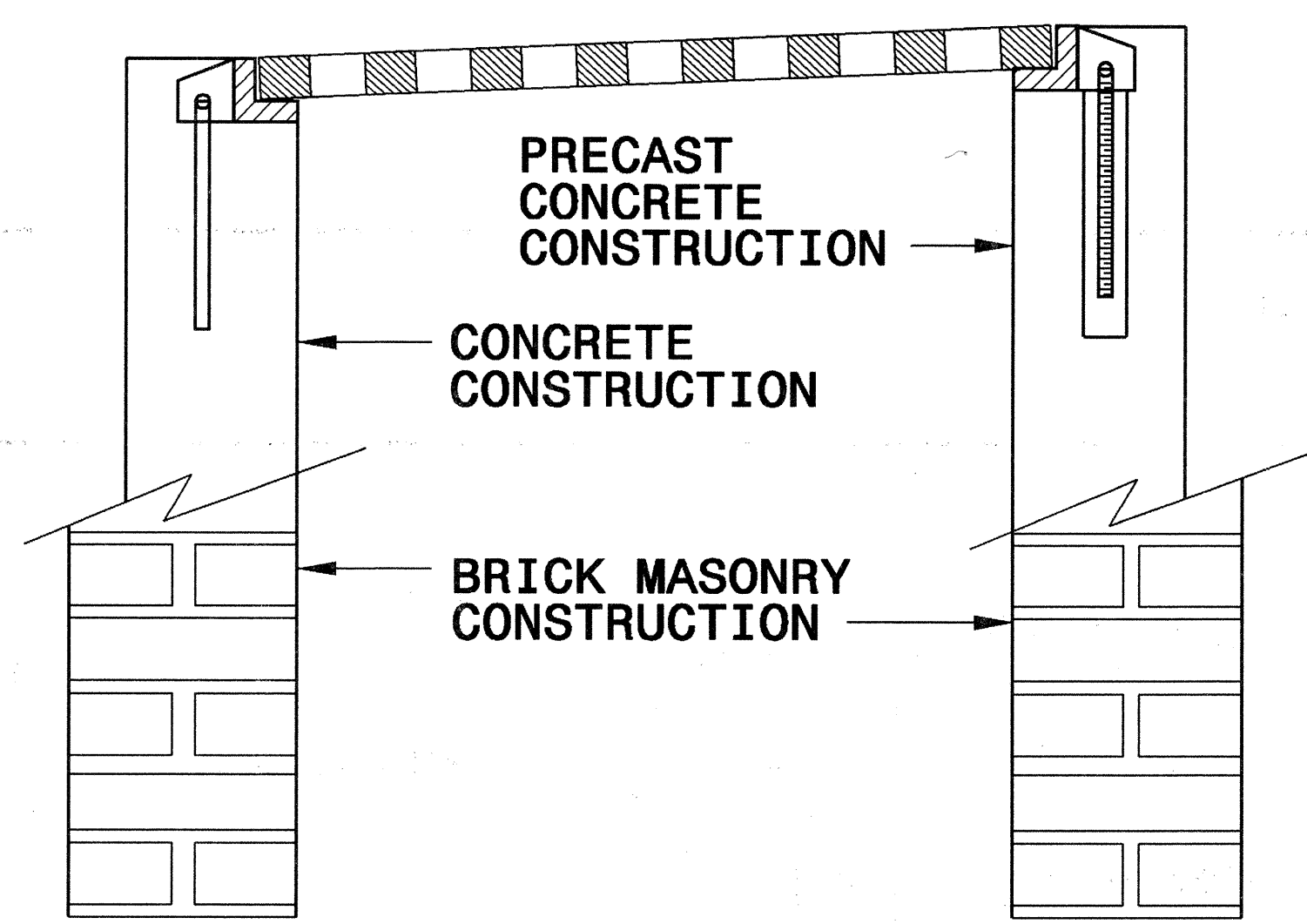

FRAME AND GRATE INSTALLATION FOR NORMAL CROWN AND SUPERELEVATED SECTIONS

STATE OF NORTH CAROLINA
DEPT. OF TRANSPORTATION
DIVISION OF HIGHWAYS
RALEIGH, N.C.

ENGLISH DETAIL DRAWING FOR
ANCHORAGE FOR FRAMES
BRICK/CONCRETE/PRECAST CONCRETE

SHEET 1 OF 1
840D25

27-SEP-2006 08:59
S:\Contracts\90379533\Special Details\ericward\stds\06\stds to Special Details\84025 Anchorage For Frames\0840d25.dgn
ericward

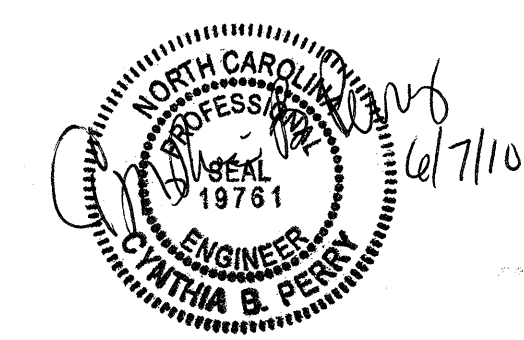

**PROJECT SERVICES UNIT
STANDARDS AND SPECIAL DESIGN**
Office 919-250-4128 FAX 919-250-4119

SEE PLATE FOR TITLE

ORIGINAL BY: 2006 STD 840.25 DATE: 07/18/06
MODIFIED BY: E.E. WARD DATE: 9/25/06
CHECKED BY: DATE:
FILE SPEC.:

STATE OF NORTH CAROLINA
DEPT. OF TRANSPORTATION
DIVISION OF HIGHWAYS
RALEIGH, N.C.

ENGLISH STANDARD DRAWING FOR
CONCRETE NARROW DROP INLET
12" THRU 24" PIPE

SHEET 1 OF 1
840D11

STATE OF NORTH CAROLINA
DEPT. OF TRANSPORTATION
DIVISION OF HIGHWAYS
RALEIGH, N.C.

ENGLISH STANDARD DRAWING FOR
CONCRETE NARROW DROP INLET
12" THRU 24" PIPE

SHEET 1 OF 1
840D11

GENERAL NOTES:

- * CLASS "B" CONCRETE TO BE USED THROUGHOUT.
- * OPTIONAL CONSTRUCTION - MONOLITHIC FOUR, 2" KEYWAY, OR #4 BAR DOWELS AT 12" CENTER, AS DIRECTED BY ENGINEER.
- * TWO 2" PIPE WEEP HOLES TO BE PLACED AS DIRECTED BY ENGINEER.
- * FORMS ARE TO BE USED FOR THE CONSTRUCTION OF THE BOTTOM SLAB.
- * IF REINFORCED CONCRETE PIPE IS SET IN BASE SLAB OF BOX, ADD TO BASE AS SHOWN ON STANDARD 840.00.
- * A STONE DRAIN CONSISTING OF 1 CUBIC FOOT OF NO. 78M STONE CONTAINED IN A BAG OF POROUS FABRIC SHALL BE PLACED AT EACH WEEP HOLE.

8-3/8" O WELDED STUD ANCHORS 8" LONG (4" + 4" ANCHORS PIGGYBACK = 8")

840D13 SHEET 2-C FRAME AND GRATE

3/8" DIA. X 8" LG. WELDED PIGGYBACK STUD ANCHORS

DOWEL SEE NOTE

SECTION X-X

SECTION Y-Y

DOWEL

PIPE	DIMENSIONS OF BOX & PIPE			CUBIC YARDS IN BOX			DEDUCTIONS FOR ONE PIPE CU. YDS.		
	SPAN	WIDTH	HEIGHT	FLOOR & WALL PER COPING FT. H	CU. YDS. MIN.	H	C.M.	R.C.	
D	A	B	H						
12"	2'-0"	0'-10"	2'-8"	0.129	0.142	0.507	0.015	0.024	
15"	2'-0"	0'-10"	3'-0"	0.129	0.142	0.555	0.023	0.036	
18"	2'-0"	0'-10"	3'-5"	0.129	0.142	0.614	0.033	0.049	
24"	2'-0"	0'-10"	4'-0"	0.129	0.142	0.697	0.059	0.085	

DIMENSIONS FOR CHANNELS

NO.	SIZE	LENGTH	TOTAL LIN. FT.
2	3" X 4.1#	2'-6"	5'-0"
	3" X 4.1#	1'-10"	3'-8"

GENERAL NOTES:

- CLASS "B" CONCRETE TO BE USED.
- ALL MORTAR JOINTS ARE 1/2" ± 1/8".
- FORMS ARE TO BE USED FOR THE CONSTRUCTION OF THE BOTTOM SLAB.
- BRICK MASONRY DROP INLET NOT TO BE USED IN LOCATIONS SUBJECT TO TRAFFIC.
- JUMBO BRICK WILL BE PERMITTED. CONCRETE BRICK OR 4" SOLID CONCRETE BLOCKS MAY BE USED IN LIEU OF CLAY BRICK.
- IF REINFORCED CONCRETE PIPE IS SET IN BASE SLAB OF BOX, ADD TO BASE AS SHOWN ON STANDARD 840.00.
- FOR 8'-0" IN HEIGHT OR LESS USE 8" WALL. OVER 8'-0" IN HEIGHT USE 12" WALL TO 6'-0" FROM TOP OF WALL AND 8" WALL FOR THE REMAINING 6'-0". QUANTITIES TO BE ADJUSTED ACCORDINGLY.

SECTION X-X

SECTION Y-Y

DOWEL

PIPE	DIMENSIONS OF BOX & PIPE			CONC. IN BASE			TOTAL BRICK MASONRY			DEDUCTIONS FOR ONE PIPE	
	SPAN	WIDTH	HEIGHT	CY. YDS.	H (MIN.)		PER FT. HEIGHT	BRICK COPING	MIN. H	C.M.	R.C.
D	A	B	H								
12"	2'-0"	0'-10"	2'-8"	0.133	2'-8"	0.206	0.025	0.574	0.020	0.032	
15"	2'-0"	0'-10"	3'-0"	0.133	3'-0"	0.206	0.025	0.643	0.031	0.047	
18"	2'-0"	0'-10"	3'-5"	0.133	3'-5"	0.206	0.025	0.729	0.044	0.065	
24"	2'-0"	0'-10"	4'-0"	0.133	4'-0"	0.206	0.025	0.849	0.078	0.113	

STATE OF NORTH CAROLINA
DEPT. OF TRANSPORTATION
DIVISION OF HIGHWAYS
RALEIGH, N.C.

ENGLISH STANDARD DRAWING FOR
BRICK NARROW DROP INLET
12" THRU 24" PIPE

SHEET 1 OF 1
840D12

GENERAL NOTES:

- CLASS "B" CONCRETE TO BE USED.
- ALL MORTAR JOINTS ARE 1/2" ± 1/8".
- FORMS ARE TO BE USED FOR THE CONSTRUCTION OF THE BOTTOM SLAB.
- BRICK MASONRY DROP INLET NOT TO BE USED IN LOCATIONS SUBJECT TO TRAFFIC.
- JUMBO BRICK WILL BE PERMITTED. CONCRETE BRICK OR 4" SOLID CONCRETE BLOCKS MAY BE USED IN LIEU OF CLAY BRICK.
- IF REINFORCED CONCRETE PIPE IS SET IN BASE SLAB OF BOX, ADD TO BASE AS SHOWN ON STANDARD 840.00.
- FOR 8'-0" IN HEIGHT OR LESS USE 8" WALL. OVER 8'-0" IN HEIGHT USE 12" WALL TO 6'-0" FROM TOP OF WALL AND 8" WALL FOR THE REMAINING 6'-0". QUANTITIES TO BE ADJUSTED ACCORDINGLY.

SECTION X-X

SECTION Y-Y

DOWEL

GENERAL NOTES:

- CLASS "B" CONCRETE TO BE USED.
- ALL MORTAR JOINTS ARE 1/2" ± 1/8".
- FORMS ARE TO BE USED FOR THE CONSTRUCTION OF THE BOTTOM SLAB.
- BRICK MASONRY DROP INLET NOT TO BE USED IN LOCATIONS SUBJECT TO TRAFFIC.
- JUMBO BRICK WILL BE PERMITTED. CONCRETE BRICK OR 4" SOLID CONCRETE BLOCKS MAY BE USED IN LIEU OF CLAY BRICK.
- IF REINFORCED CONCRETE PIPE IS SET IN BASE SLAB OF BOX, ADD TO BASE AS SHOWN ON STANDARD 840.00.
- FOR 8'-0" IN HEIGHT OR LESS USE 8" WALL. OVER 8'-0" IN HEIGHT USE 12" WALL TO 6'-0" FROM TOP OF WALL AND 8" WALL FOR THE REMAINING 6'-0". QUANTITIES TO BE ADJUSTED ACCORDINGLY.

SECTION X-X

SECTION Y-Y

DOWEL

**PROJECT SERVICES UNIT
STANDARDS AND SPECIAL DESIGN**
Office 919-250-4128 FAX 919-250-4119

NARROW DROP INLET

ORIGINAL BY: _____ DATE: _____
 MODIFIED BY: rnbritt DATE: 09-11-09
 CHECKED BY: _____ DATE: 9/23/09
 FILE SPEC.: details/nbritt/english/urban/u5018a.dgn



STATE OF
NORTH CAROLINA
DEPT. OF TRANSPORTATION
RALEIGH, N.C.

ENGLISH DETAIL DRAWING FOR
NARROW DROP INLET FRAME AND GRATE
FOR USE WITH DETAIL 840D11 & 840D12

SHEET 1 OF 1
840D13

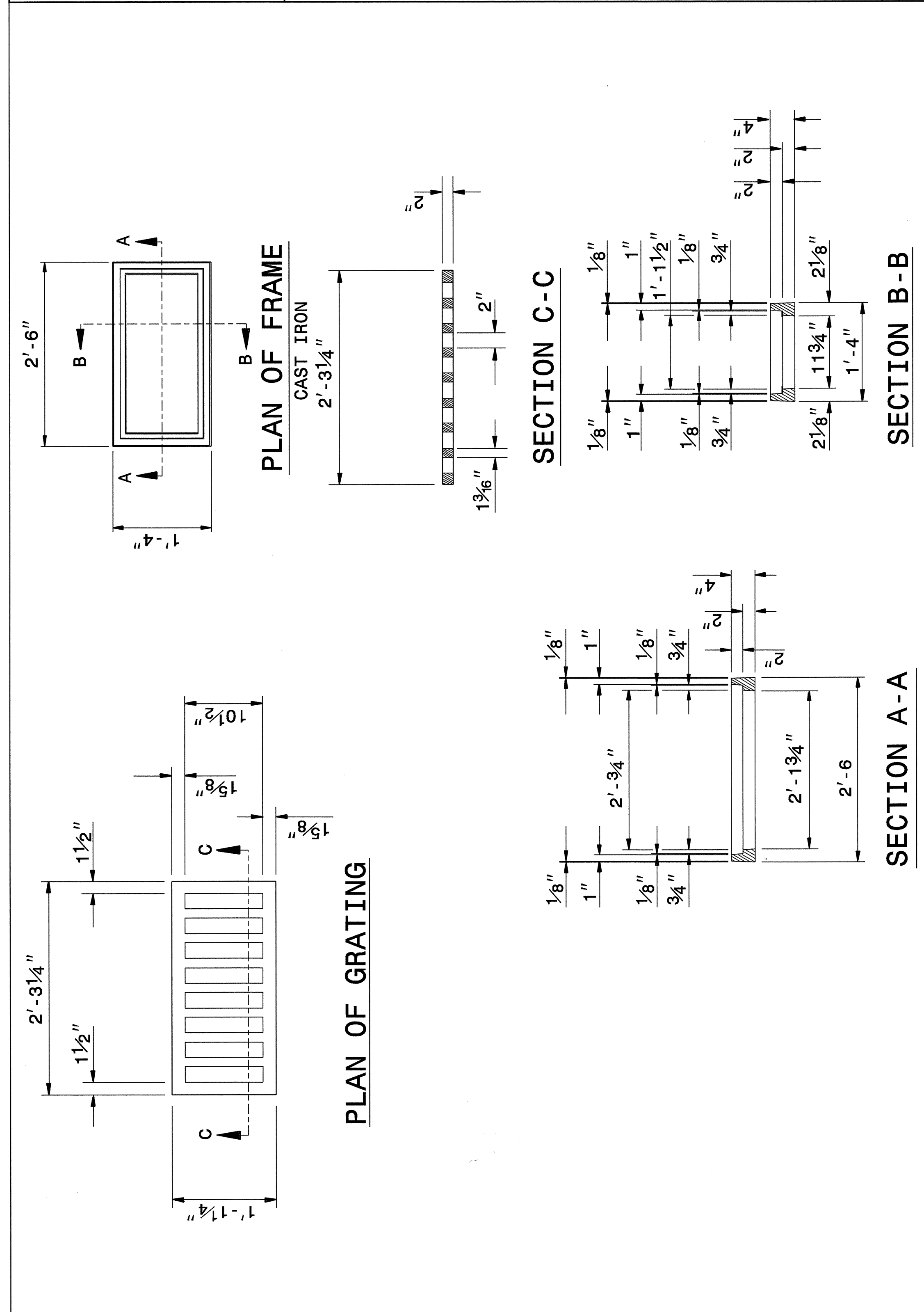

STATE OF
NORTH CAROLINA
DEPT. OF TRANSPORTATION
DIVISION OF HIGHWAYS
RALEIGH, N.C.

ENGLISH DETAIL DRAWING FOR
NARROW DROP INLET FRAME AND GRATE
FOR USE WITH DETAIL 840D11 & 840D12

SHEET 1 OF 1
840D13

STATE OF
NORTH CAROLINA
DEPT. OF TRANSPORTATION
RALEIGH, N.C.

ENGLISH DETAIL DRAWING FOR
**METHOD FOR PLACEMENT OF
DROP INLETS IN ISLANDS**

SHEET 1 OF 1
852D03

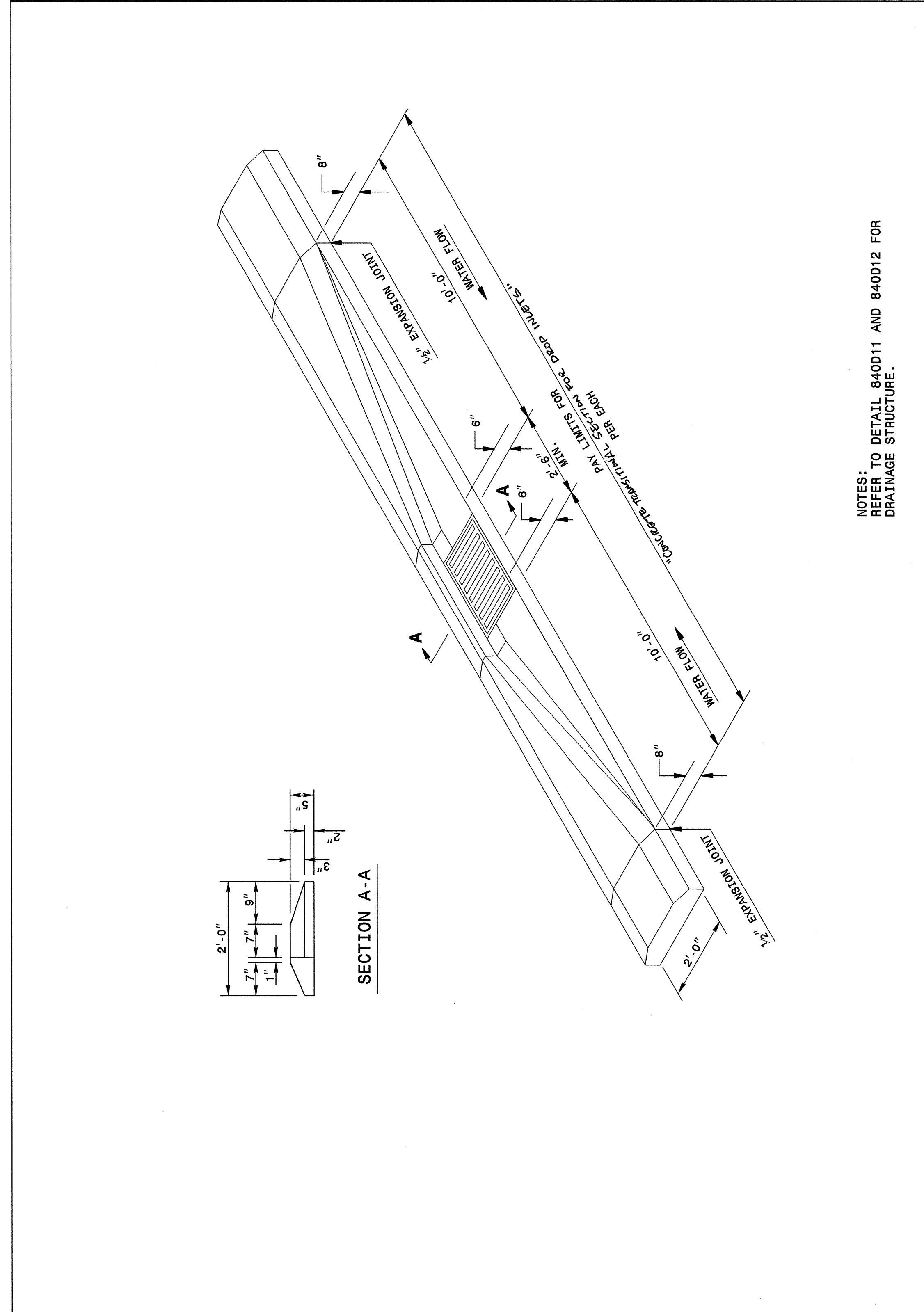

STATE OF
NORTH CAROLINA
DEPT. OF TRANSPORTATION
DIVISION OF HIGHWAYS
RALEIGH, N.C.

ENGLISH DETAIL DRAWING FOR
**METHOD FOR PLACEMENT OF
DROP INLETS IN ISLANDS**

SHEET 1 OF 1
852D03

NOTES:
REFER TO DETAIL 840D11 AND 840D12 FOR
DRAINAGE STRUCTURE.

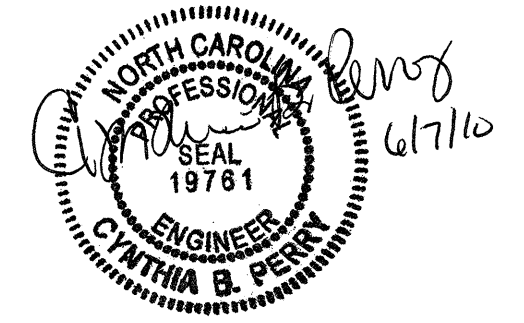

**DESIGN SERVICES UNIT
STANDARDS AND SPECIAL DESIGN**
Office 919-250-4128 FAX 919-250-4119

SEE PLATE FOR TITLE

ORIGINAL BY: 1998 STDS DATE: 9-11-09
MODIFIED BY: cnbritt DATE: 9/23/09
CHECKED BY: DATE: 9/23/09
FILE SPEC.: details/nbritt/english/hydro/u5018a.dgn

MATERIALS

A	GEOTEXTILE FABRIC (SEE SHEET 2-H)
B	POLYPROPYLENE WOVEN MONOFILAMENT GEOTEXTILE FABRIC (SEE SHEET 2-H)
D	15" DRAINAGE PIPE (INLET)
E	15" DRAINAGE PIPE (OUTFALL)
F	TWO LINES OF 6" PERFORATED HDPE D/W (UNDERDRAIN PIPE) (SEE SHEET 2-I)
G	6" HDPE D/W SOLID CLEANOUT PIPE (SEE SHEET 2-H)
H	PRECAST DI BOX (SEE SHEET 2-F)
I	1' MIN. THICKNESS OF ENGINEERED SOIL (80%-85% SAND, 8%-12% FINES (SILT & CLAY), 3%-5% ORGANICS) (FILTER BED)
J	12" THICK, WASH STONE NO. 57 AS PER NCDOT SPEC. (UNDERDRAIN SYSTEM SEE SHEET 2-H & 2-I)

BASIN	DIMENSIONS FOR UNDERDRAIN PIPE & FILTER BED		
	UNDERDRAIN PIPE DIM.	FILTER BED DIMENSIONS AT EL. 36.0	
	LENGTH	WIDTH	LENGTH
-L- 55+43.3	21.0'	4.5'	32.0'

TABLE "A"

SCALE:
1" = 20'

NOTE:

ENGINEERED SOIL SURFACE AREA AT ELEV. 36.0 = 118.0 SF.
BOTTOM OF BASIN SURFACE AREA AT ELEV. 36.0 = 295.0 SF.
BOTTOM OF FOREBAY SURFACE AREA AT ELEV. 36.0 = 15.4 SF.



PROJECT REFERENCE NO. U-5018A SHEET NO. 2-D

ROADWAY DESIGN ENGINEER

HYDRAULICS ENGINEER

SEAL 31977

6-7-10

DRY DETENTION DETAIL (-L-55+43.3)

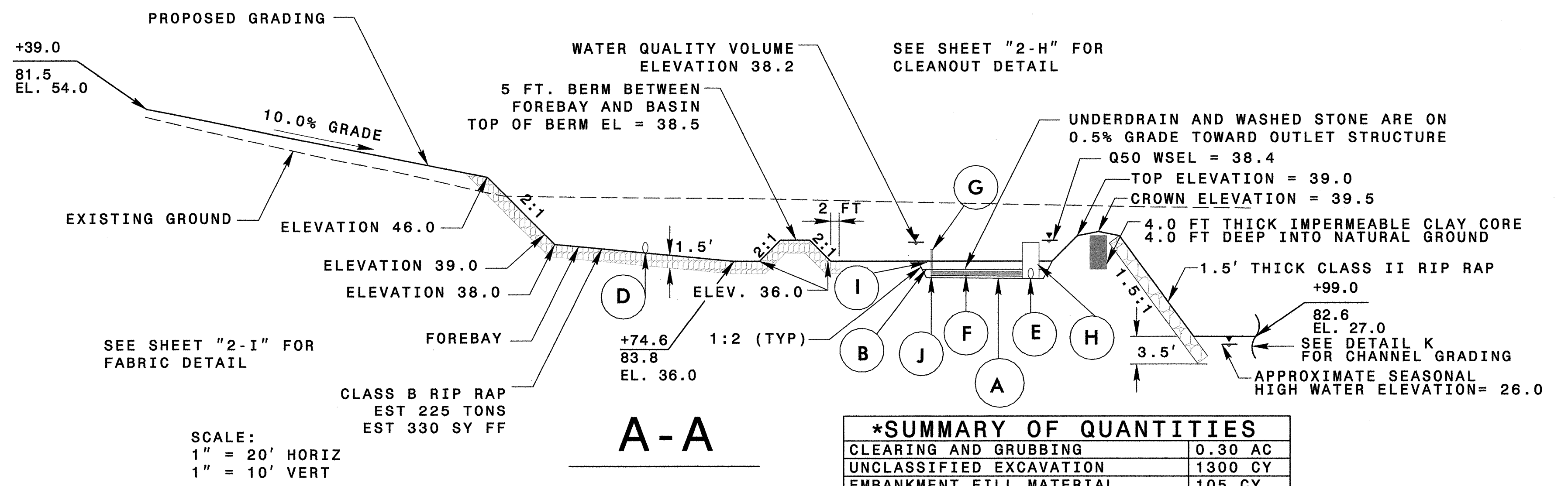
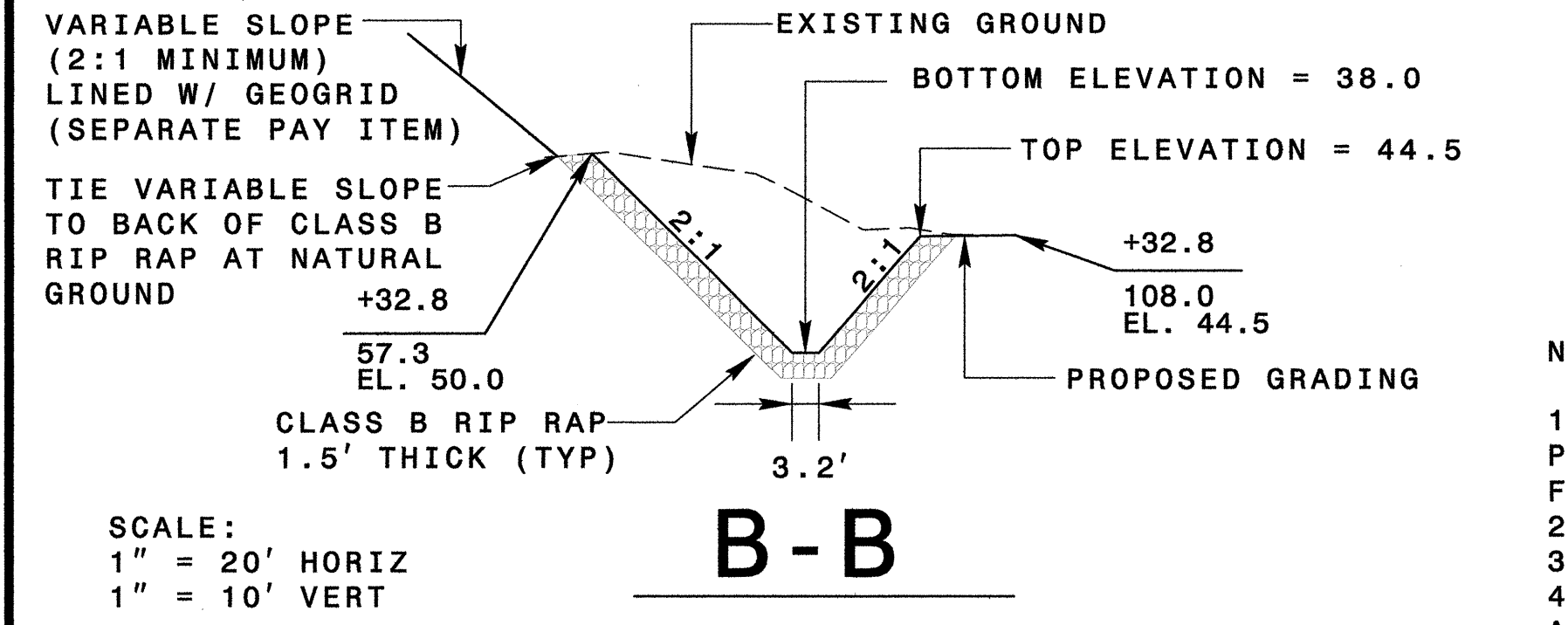
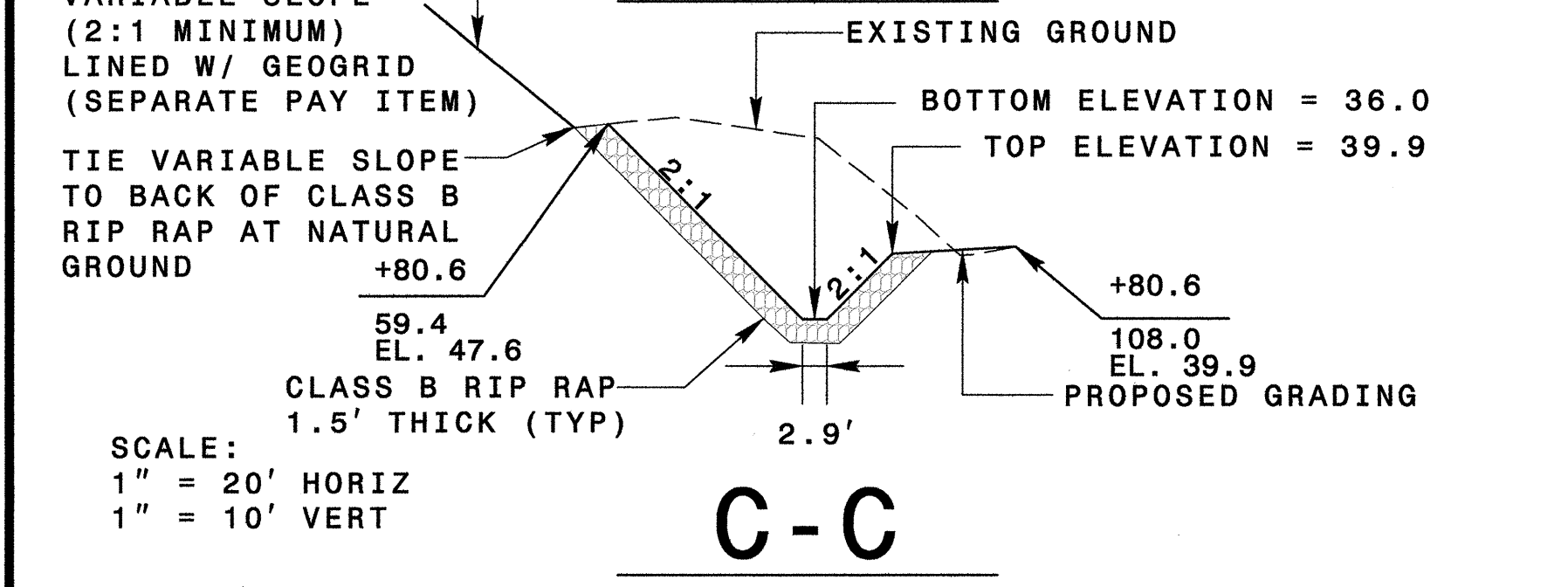
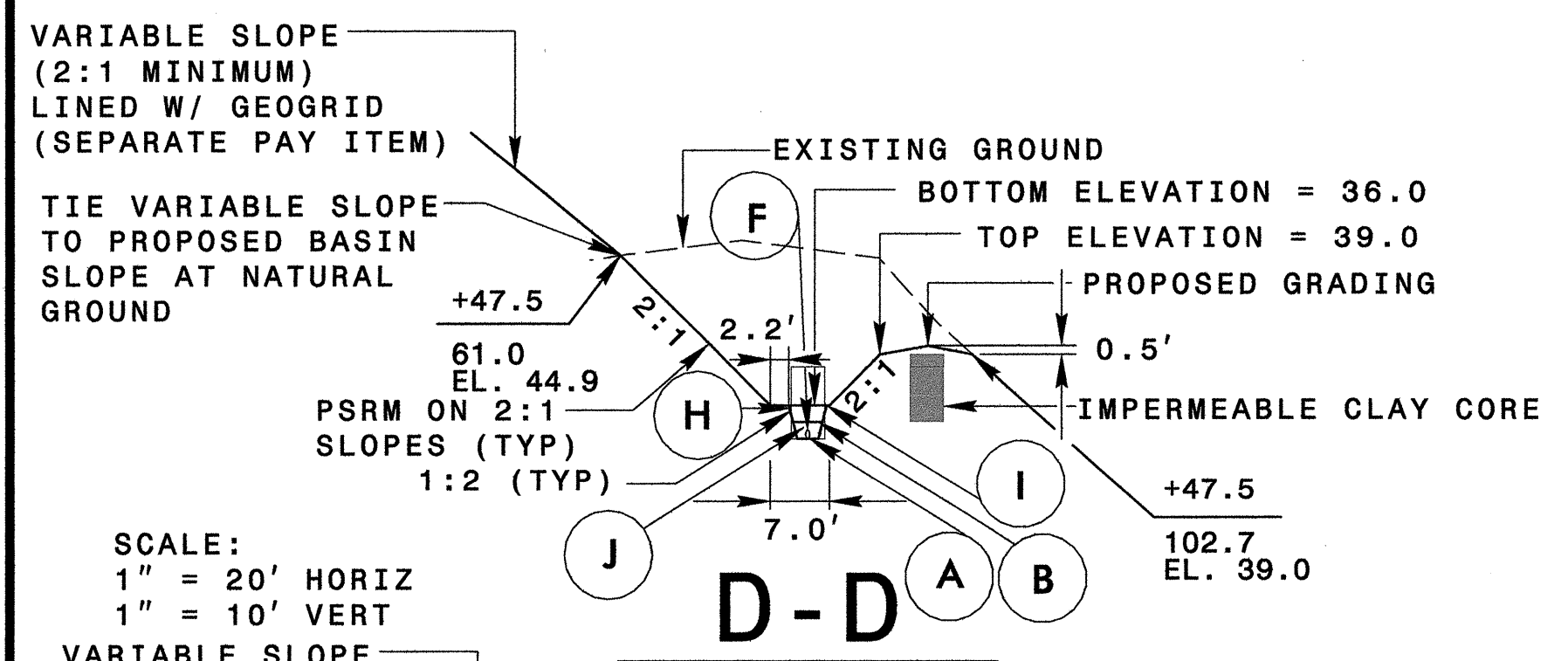
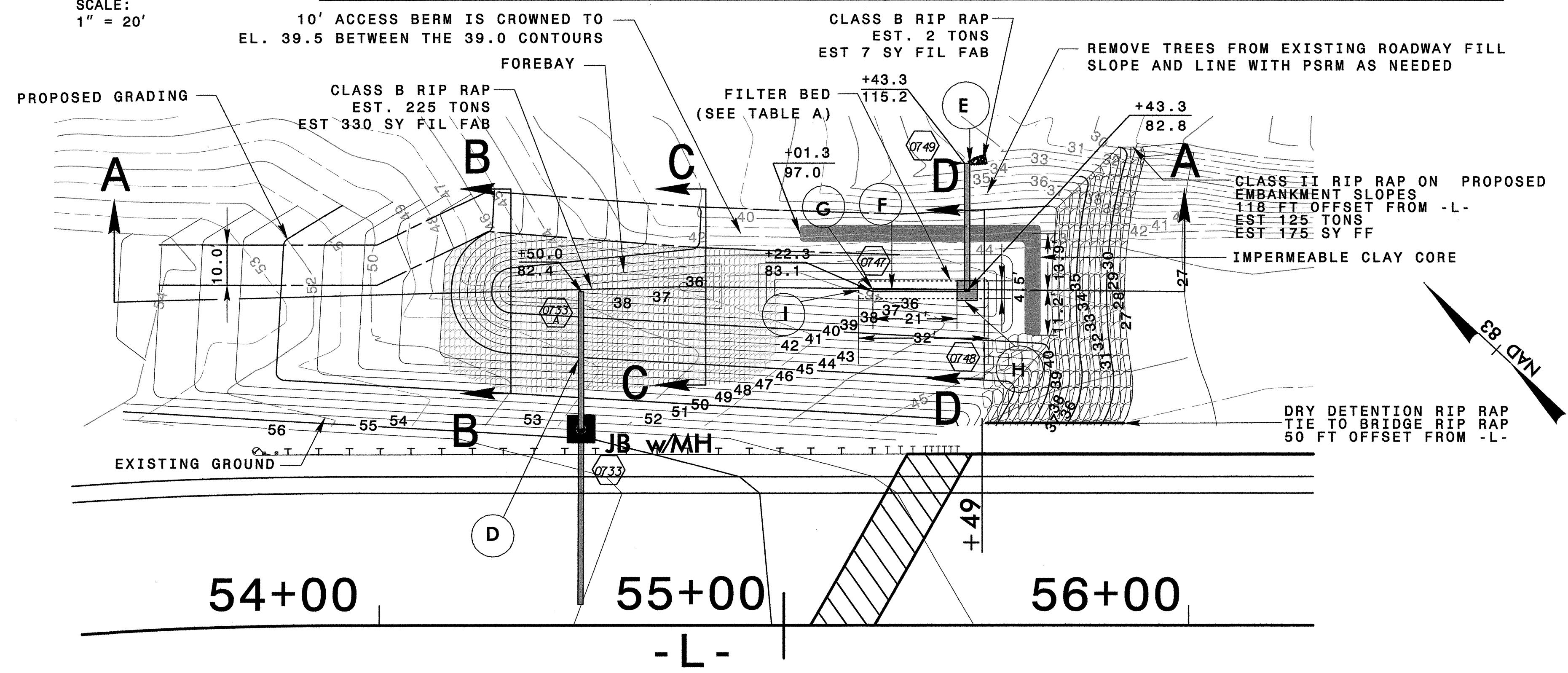

***SUMMARY OF QUANTITIES**

CLEARING AND GRUBBING	0.30 AC
UNCLASSIFIED EXCAVATION	1300 CY
EMBANKMENT FILL MATERIAL	105 CY
CLAY CORE MATERIAL	50 CY
WASHED 57 STONE	11 TONS
RIP RAP CLASS 'B'	227 TONS
RIP RAP CLASS 'II'	125 TONS
ENGINEERED SOIL	8 CY
SOD	20 SY
SEEDING AND MULCHING	0.20 AC
MOWING	0.20 AC
POLYPROPYLENE WOVEN MONOFILAMENT GEOTEXTILE FABRIC	25 SY
GEOTEXTILE FABRIC	25 SY
PSRM	220 SY

*NOTE: BOXES AND PIPES ARE QUANTIFIED ON DRAINAGE SUMMARY SHEET

- NOTES**
1. BASIN WILL BE SEEDED AND FERTILIZED WITH NATIVE GRASSES PER SECTION 16-60 OF NCDOT'S STANDARD SPECIFICATIONS FOR ROADS AND STRUCTURES
 2. BASIN EXCAVATION ESTIMATED AT 1300 CY
 3. BASIN FILL ESTIMATED AT 105 CY
 4. PERMANENT SOIL REINFORCEMENT MATTING TO BE USED ON ALL 2:1 SLOPES AND GREATER THAT ARE NOT RIP RAPPED.

6/7/2010 5:21:52 PM C:\Hydr\05018A\Hyd\det_55433.dgn

MATERIALS

A	GEOTEXTILE FABRIC (SEE SHEET 2-H)
B	POLYPROPYLENE WOVEN MONOFILAMENT GEOTEXTILE FABRIC (SEE SHEET 2-H)
D	15" DRAINAGE PIPE (INLET)
E	15" DRAINAGE PIPE (OUTFALL)
F	TWO LINES OF 6" PERFORATED HDPE D/W (UNDERDRAIN PIPE) (SEE SHEET 2-I)
G	6" HDPE D/W SOLID CLEANOUT PIPE (SEE SHEET 2-H)
H	PRECAST DI BOX (SEE SHEET 2-F)
I	1' MIN. THICKNESS OF ENGINEERED SOIL (80%-85% SAND, 8%-12% FINES (SILT & CLAY), 3%-5% ORGANICS) (FILTER BED)
J	12" THICK, WASH STONE NO. 57 AS PER NCDOT SPEC. (UNDERDRAIN SYSTEM SEE SHEET 2-H & 2-I)

BASIN	DIMENSIONS FOR UNDERDRAIN PIPE & FILTER BED		
	UNDERDRAIN PIPE DIM. LENGTH	FILTER BED DIMENSIONS AT EL. 36.0 WIDTH	FILTER BED DIMENSIONS AT EL. 36.0 LENGTH
-L- 57+34.6	15.0'	7.0'	22.0'

NOTE:

ENGINEERED SOIL SURFACE AREA AT ELEV. 36.0 = 129.0 SF.
 BOTTOM OF BASIN SURFACE AREA AT ELEV. 36.0 = 611.5 SF.
 BOTTOM OF FOREBAY SURFACE AREA AT ELEV. 34.0 = 30.0 SF.



PROJECT REFERENCE NO. U-5018A	SHEET NO. 2-E
ROADWAY DESIGN ENGINEER	HYDRAULICS ENGINEER

Professional Engineer Seal: NORTH CAROLINA PROFESSIONAL ENGINEER SEAL 31977

TABLE "A" DRY DETENTION DETAIL (-L- 57+34.6)

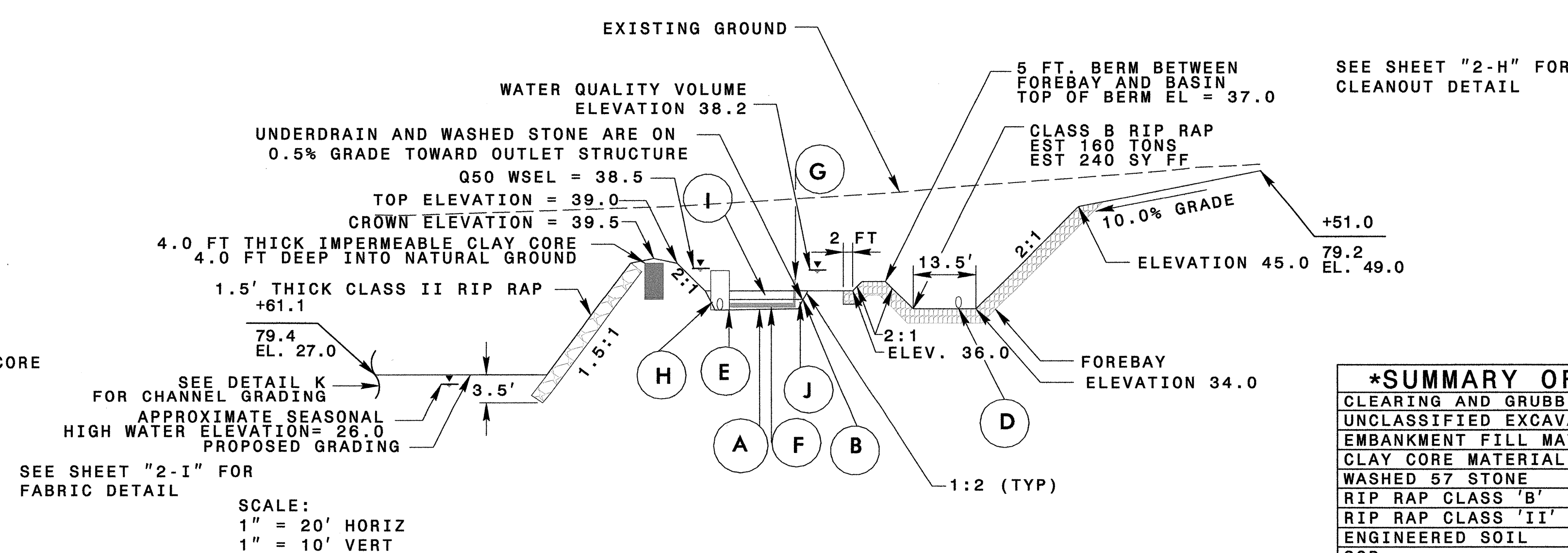
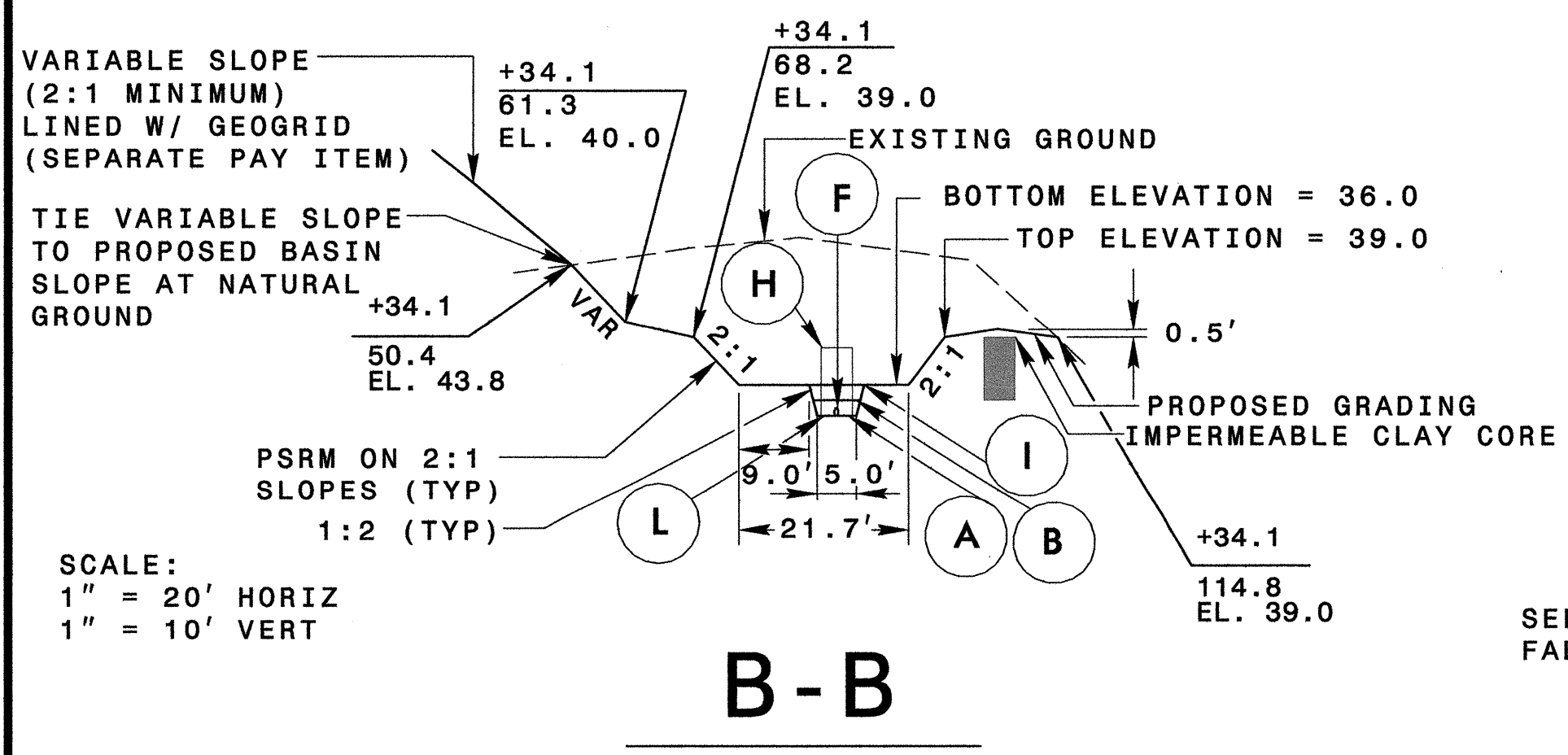
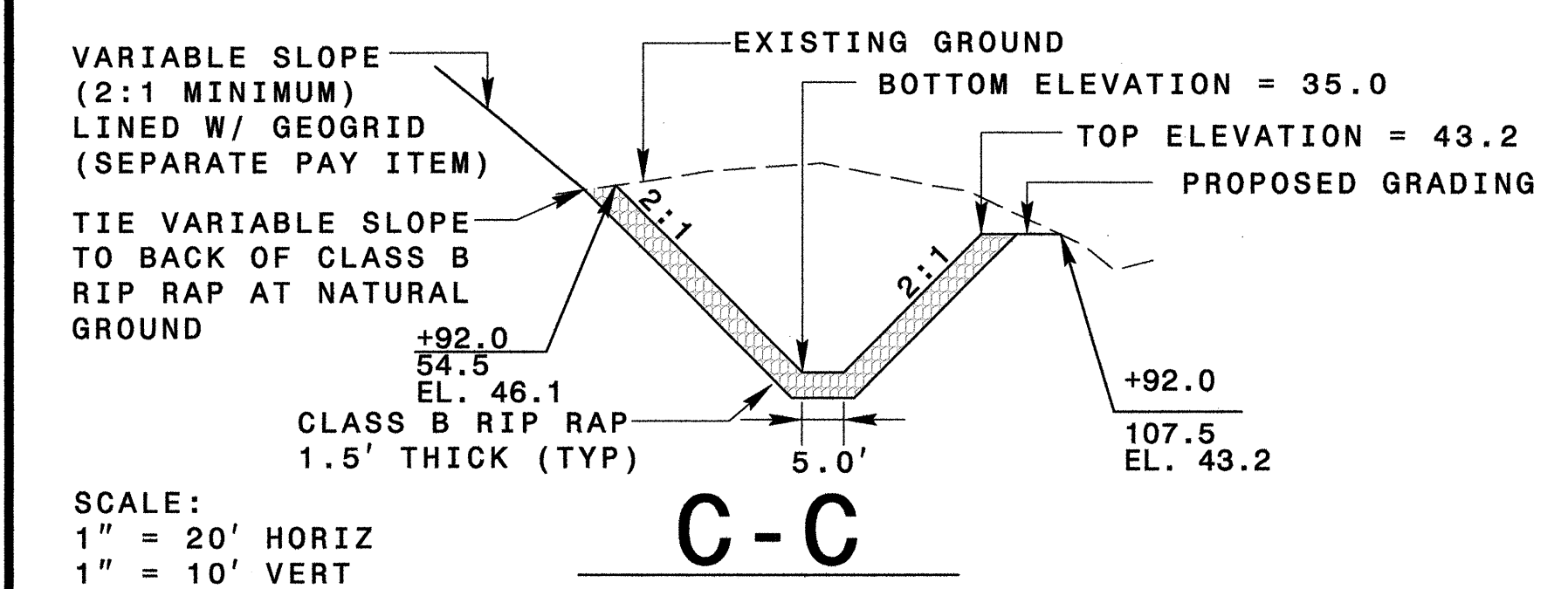
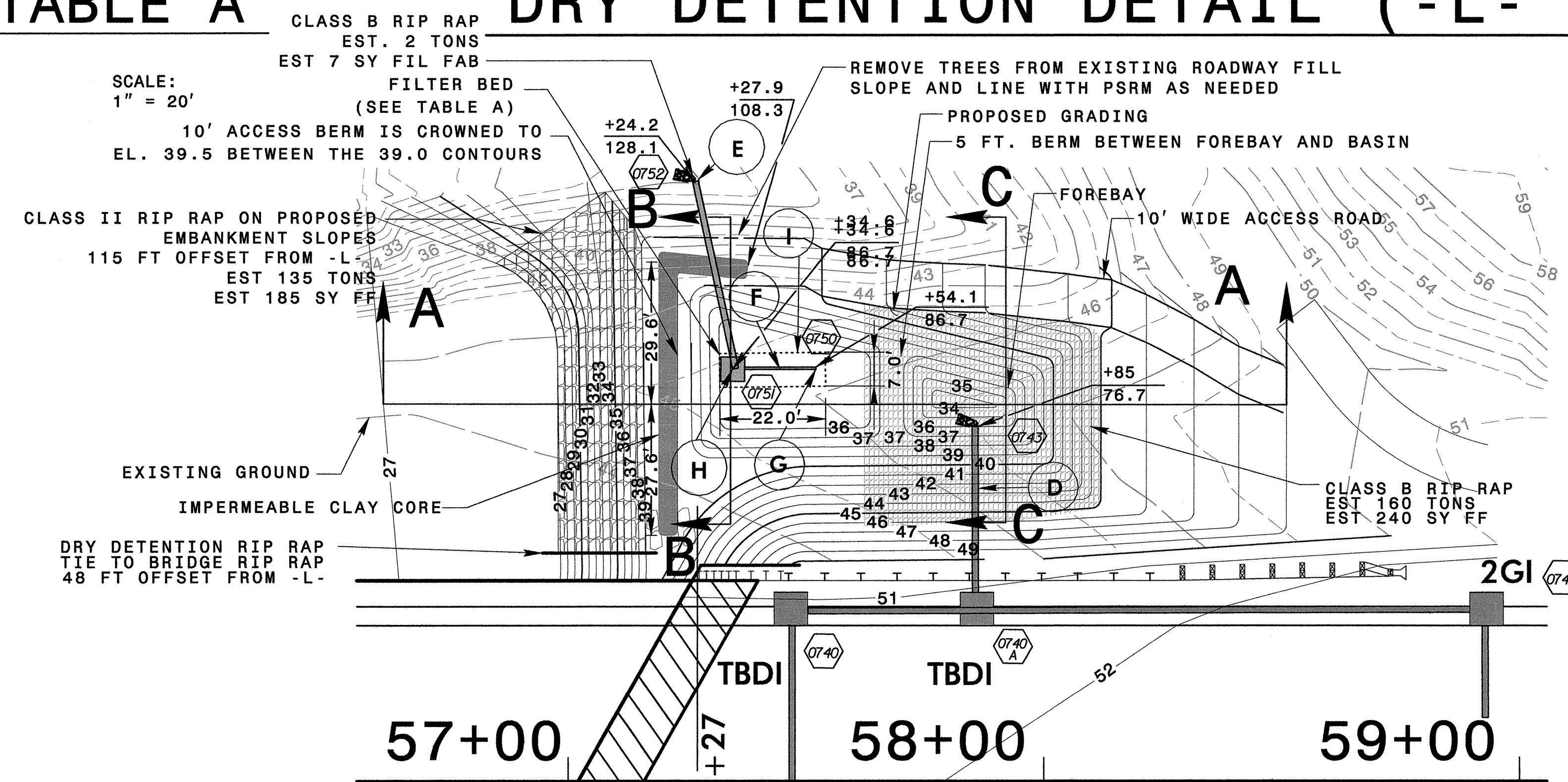

- NOTES
1. BASIN WILL BE SEEDED AND FERTILIZED WITH NATIVE GRASSES PER SECTION 16-60 OF NCDOT'S STANDARD SPECIFICATIONS FOR ROADS AND STRUCTURES
 2. BASIN EXCAVATION ESTIMATED AT 1340 CY
 3. BASIN FILL ESTIMATED AT 95 CY
 4. PERMANENT SOIL REINFORCEMENT MATTING TO BE USED ON ALL 2:1 SLOPES AND GREATER THAT ARE NOT RIP RAPPED.

*SUMMARY OF QUANTITIES	
CLEARING AND GRUBBING	0.22 AC
UNCLASSIFIED EXCAVATION	1340 CY
EMBANKMENT FILL MATERIAL	95 CY
CLAY CORE MATERIAL	45 CY
WASHED 57 STONE	8 TONS
RIP RAP CLASS 'B'	162 TONS
RIP RAP CLASS 'II'	135 TONS
ENGINEERED SOIL	8 CY
SOD	20 SY
SEEDING AND MULCHING	0.14 AC
MOWING	0.14 AC
POLYPROPYLENE WOVEN MONOFILAMENT GEOTEXTILE FABRIC	20 SY
GEOTEXTILE FABRIC	20 SY
PSRM	200 SY

*NOTE: BOXES AND PIPES ARE QUANTIFIED ON DRAINAGE SUMMARY SHEET

6/7/2010 5:23:50 PM C:\Users\CAADD\U5018A-Hyd_det_5734.6.dgn

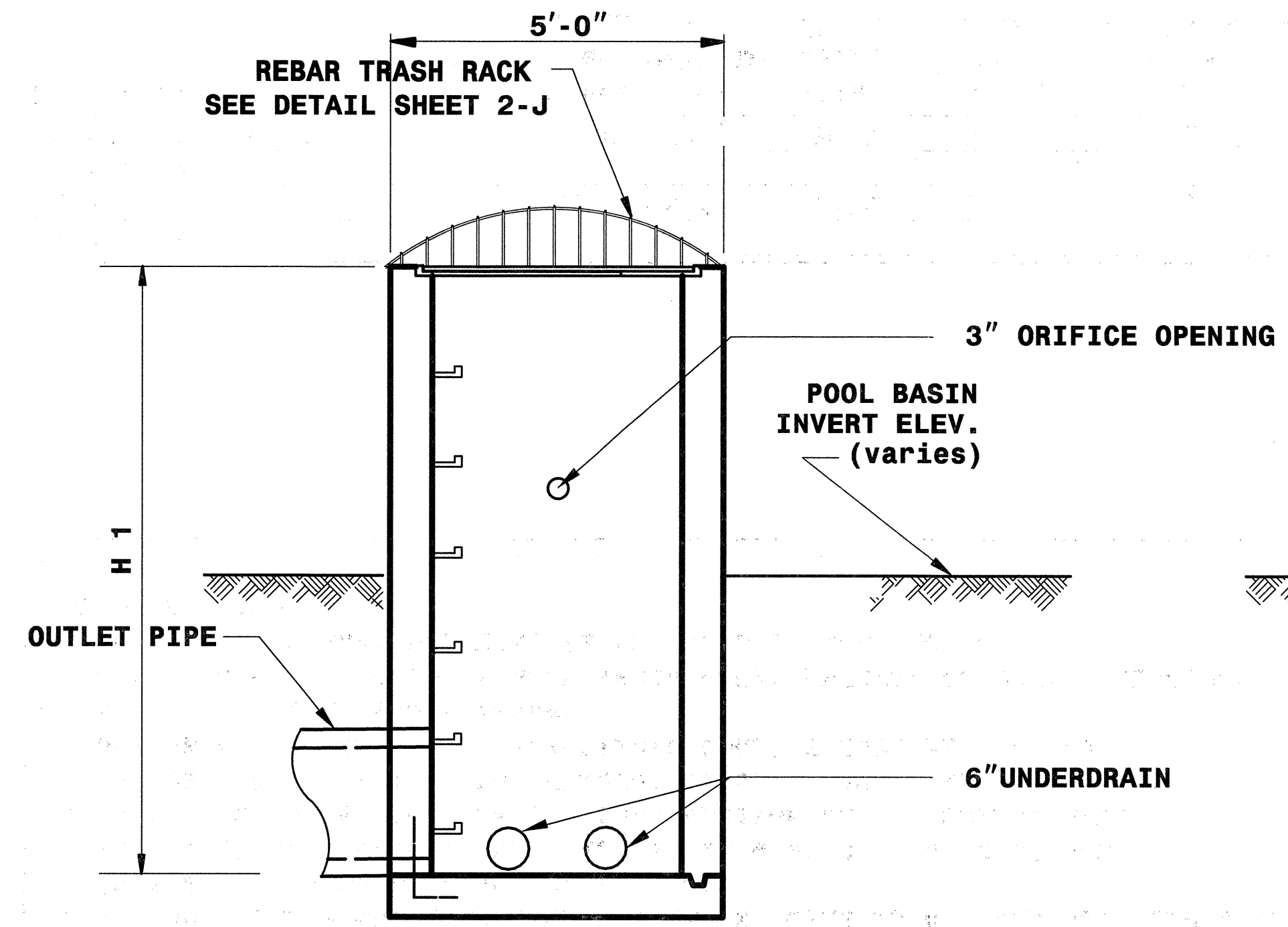

STRUCTURE SIDE 1

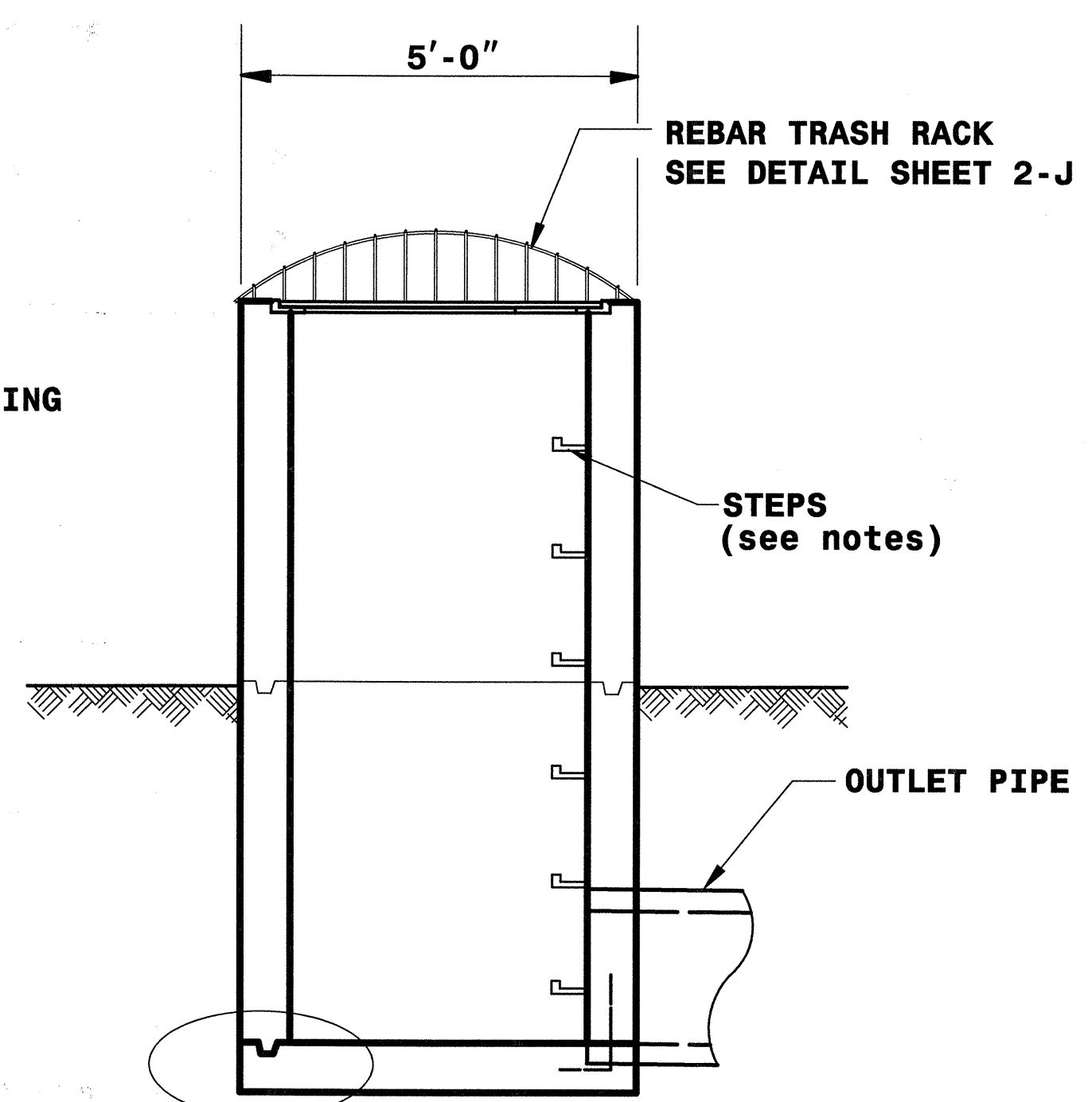

STRUCTURE SIDE 2

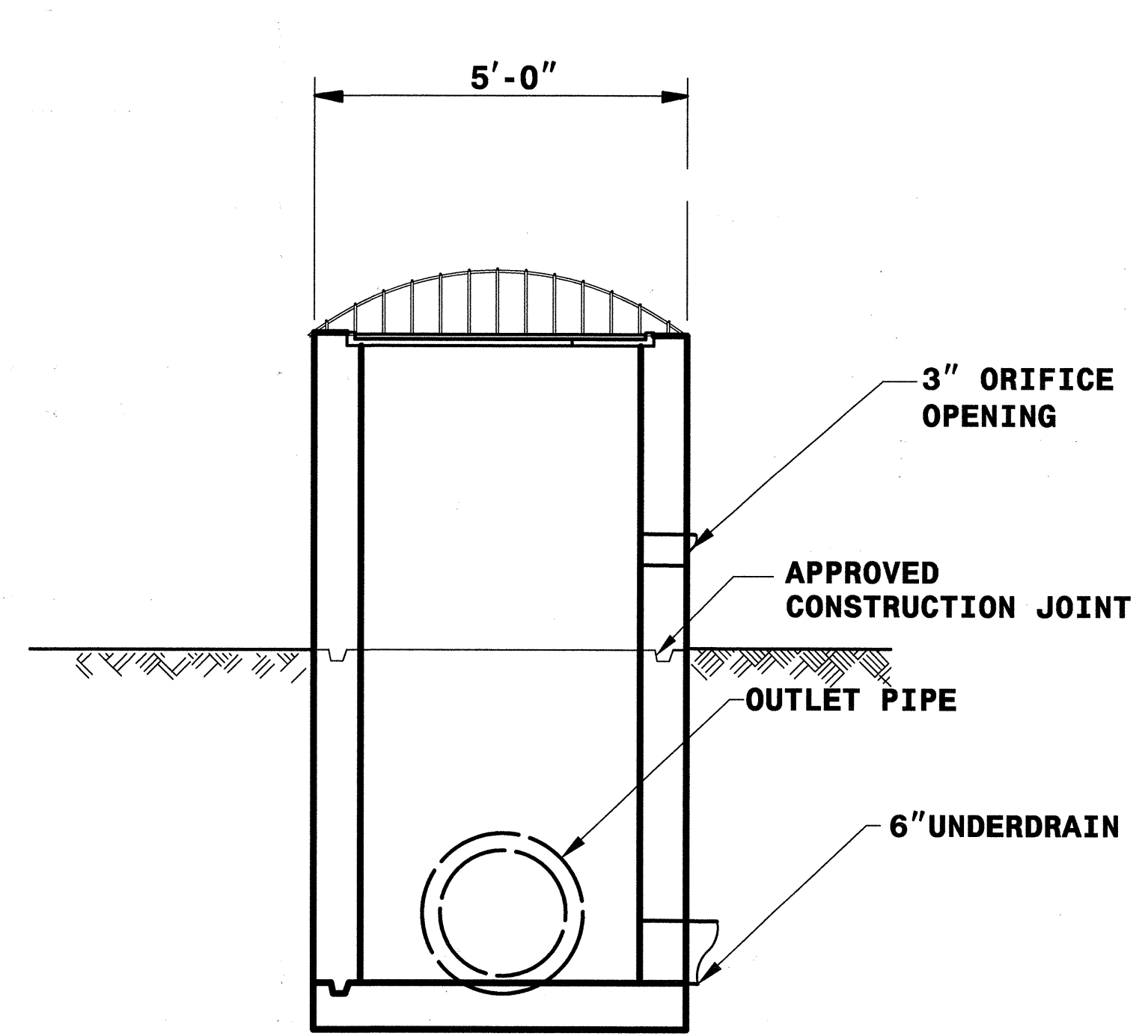

STRUCTURE FRONT

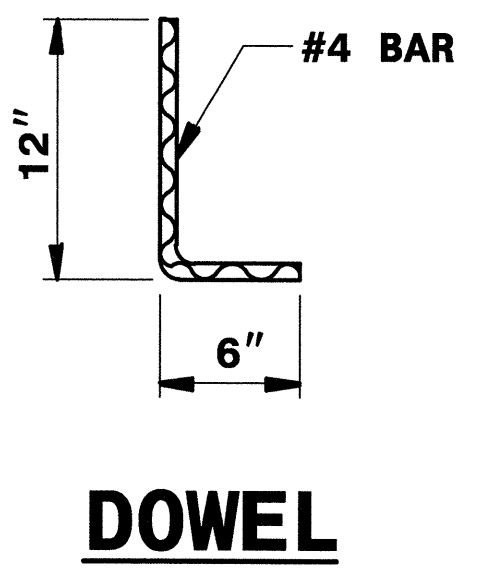
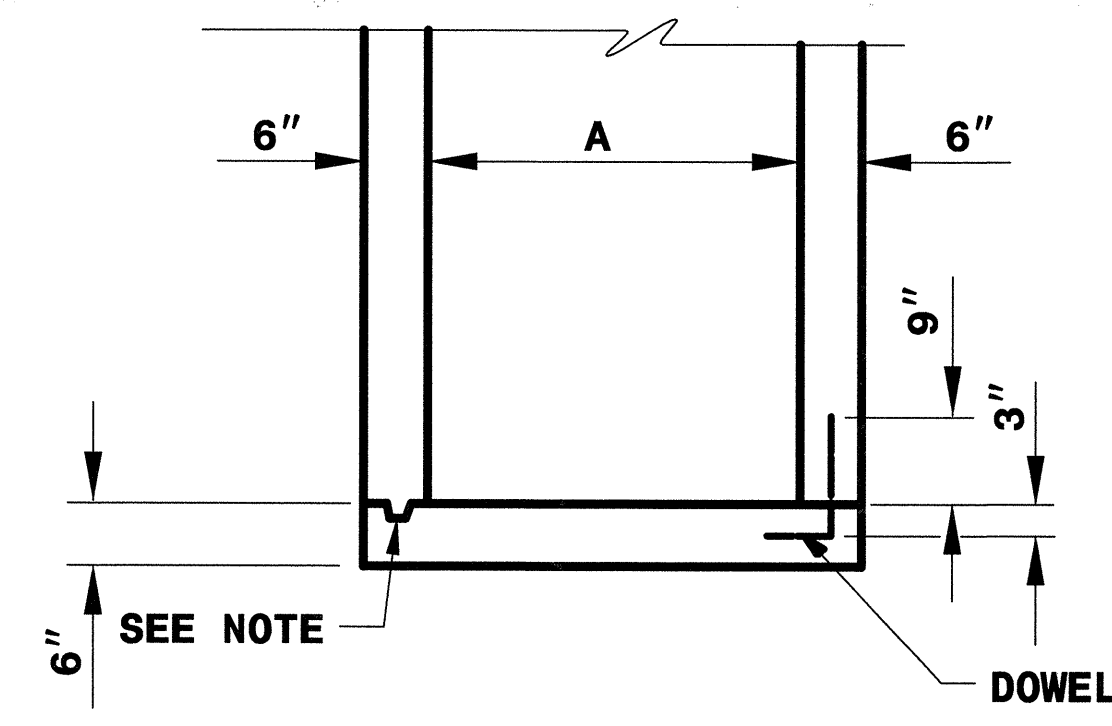
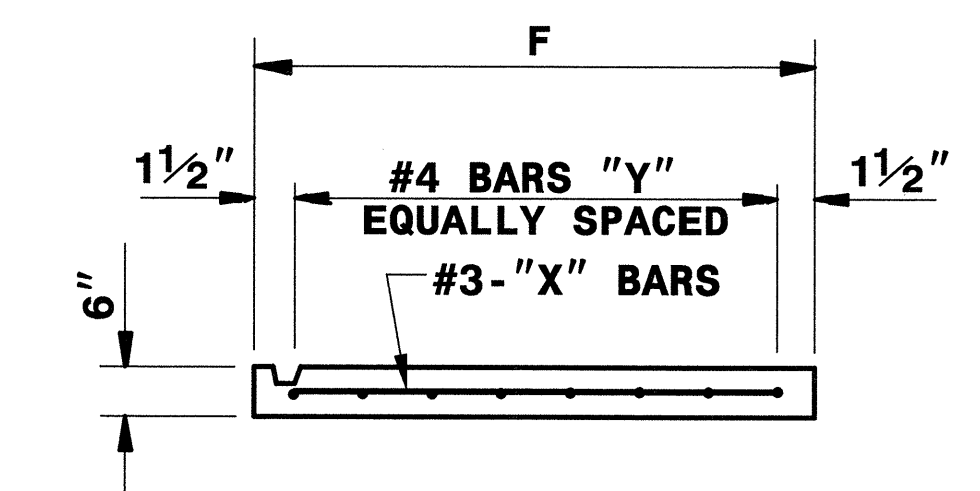

TABLE "A"

MINIMUM DIMENSIONS FOR OUTLET CONTROL STRUCTURE							
BASIN	PIPE DIA.	OUTLET PIPE INVERT	BOX HEIGHT H1	TOP OF GRATE ELEV.	UNDER DRAIN INVERT	ORFICE PLATE OPENING INVERT	POOL BASIN ELEV. @ PAD ELEV.
Sta. 55+43.3 -L- (82.8 Lt)	15"	33.8'	4.4'	38.2'	33.8'	37.0'	36.0'
Sta. 57+34.6 -L- (86.7 Lt)	15"	33.9'	4.3'	38.2'	33.9'	37.0'	36.0'



DETAIL 'B'



BOTTOM SLAB

GENERAL NOTES:

- * CHANGES IN ELEVATIONS MUST BE APPROVED BY THE ENGINEER.
- * CLASS 'B' CONCRETE TO BE USED THROUGHOUT. PRECAST CONCRETE STRUCTURES TO BE SUBMITTED FOR APPROVAL.
- * OPTIONAL CONSTRUCTION - MONOLITHIC POUR, 2 INCH KEYWAY, OR #4 BAR DOWELS AT 12 INCH CENTERS, AS DIRECTED BY THE ENGINEER.
- * FORMS ARE TO BE USED FOR THE CONSTRUCTION OF THE BOTTOM SLAB.
- * IF REINFORCED CONCRETE PIPE IS SET IN BASE SLAB OF BOX, ADD TO BASE AS SHOWN ON STANDARD 840.00.
- * ALL DRAWDOWN STRUCTURES OVER 3 FEET IN DEPTH TO BE PROVIDED WITH STEPS 12 INCH ON CENTERS. STEPS SHALL BE INSTALLED IN ACCORDANCE WITH STANDARD 840.66.
- * WALL THICKNESS SHALL BE IN ACCORDANCE TO STD. # 840.31 AND # 840.32
- * RETICULINE FRAME AND GRATE TO BE APPROVED BY THE ENGINEER.

PRECAST DI BOX

DRY DETENTION BASIN NOTES

SEQUENCE OF CONSTRUCTION FOR DRY DETENTION BASIN

1. PUT IN ALL EROSION CONTROL MEASURES
(AS NEEDED THROUGH CONSTRUCTION STAGES).
2. EXCAVATE THE BASIN.
PREPARE THE BASIN FLOOR AT THE GIVEN GRADE.
3. CONSTRUCT BERM AROUND BASIN.
4. CONSTRUCT UNDERDRAIN SYSTEM
(SEE DETAIL SHEETS 2-H AND 2-I)
5. FINE GRADE ELEVATIONS
6. CONSTRUCT AND INSTALL BOXES.
CREATE OPENINGS IN BOXES
AND CONNECT PIPES WITH BOXES.
7. ADD GRATES/TRASH RACK ON ALL BOXES.

MAINTENANCE RECOMMENDATIONS

1. REMOVE DEBRIS, TRASH AND SEDIMENT BUILDUP FROM THE BASIN
AS NECESSARY TO MINIMIZE OUTLET CLOGGING AND IMPROVE AESTHETICS.
2. REPAIR AND REVEGETATE ERODED AREAS AS NEEDED.
3. CHECK INLETS AND OUTLETS FOR STRUCTURAL REPAIR TO CONFIRM THAT
THEY ARE OPERATIONAL.
4. MOW AS NECESSARY TO LIMIT UNWANTED VEGETATION AND REMOVE
CLIPPINGS AS PRACTICAL.
5. FOREBAY MUST RECIEVE REGULAR MAINTENANCE TO REMAIN EFFECTIVE

GENERAL NOTES FOR DRY DETENTION BASIN

1. APPLY SEEDING OVER THE SIDE SLOPES OF BERM AND
ANY EXPOSED SURFACE THAT NEEDS TO BE PROTECTED
AGAINST IMMEDIATE POTENTIAL STORM EVENT.
2. THE SURVEYOR SHALL VERIFY THE INVERTS AND ELEVATIONS
AT THE FOLLOWING POINTS AT THE END OF EACH PHASE OF CONSTRUCTION:
-INVERTS IN THE PIPE AND THE BOXES
-INVERTS AT THE HIGH AND LOW POINTS OF THE ENGINEERED SOILS
3. ALL EMBANKMENTS AND FILL MATERIAL SHALL BE COMPACTED TO AT LEAST
TO NCDOT STANDARD SPECIFICATION 2-35

IMPERMEABLE CLAY LINER SPECIFICATION

THE IMPERMEABLE CLAY LAYER SHALL HAVE THE FOLLOWING PROPERTIES:

1. UNIFIED SOIL CLASSIFICATION "CL".
2. LIQUID LIMIT BETWEEN 25 AND 40.
3. PLASTICITY INDEX BETWEEN 20 AND 30.
4. IMPERVIOUS TO FLOW OF WATER WHEN A 12" THICK
LAYER IS COMPACTED TO 90% RELATIVE COMPACTION PER ASTM D-1557.

UNDERDRAIN FABRIC

*NOT TO SCALE

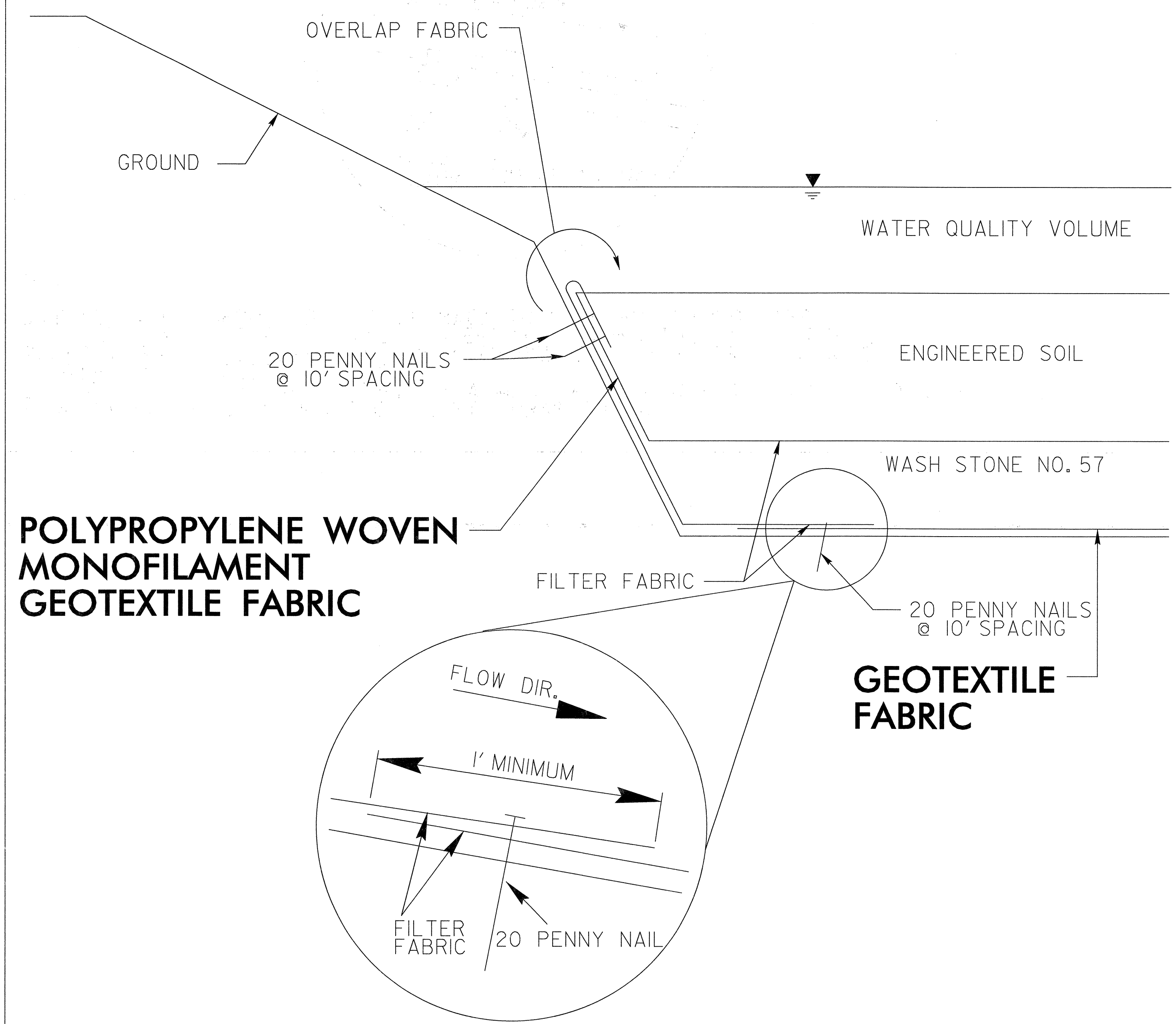

**POLYPROPYLENE WOVEN
MONOFILAMENT
GEOTEXTILE FABRIC**

**GEOTEXTILE
FABRIC**

- NOTES:
1. LINING FABRIC SHOULD BE FOLDED BACK TO OVERLAP DIVIDING FABRIC AND SECURED WITH 20 PENNY NAILS TO ENURE SEALING THE STONE FROM SOIL.
 2. FABRIC SHOULD BE LAYED IN A WAY TO PREVENT WATER FROM FLOWING BETWEEN OVERLAPPED PIECES. (SEE BLOWUP)
 3. FABRIC SHOULD BE OVERLAPPED BY A MINIMUM OF 12 INCHES AND SECURED WITH NAILS.
 4. NO OVERLAPPING SHOULD OCCUR UNDER DRAIN PIPES.

CLEANOUT

*NOT TO SCALE

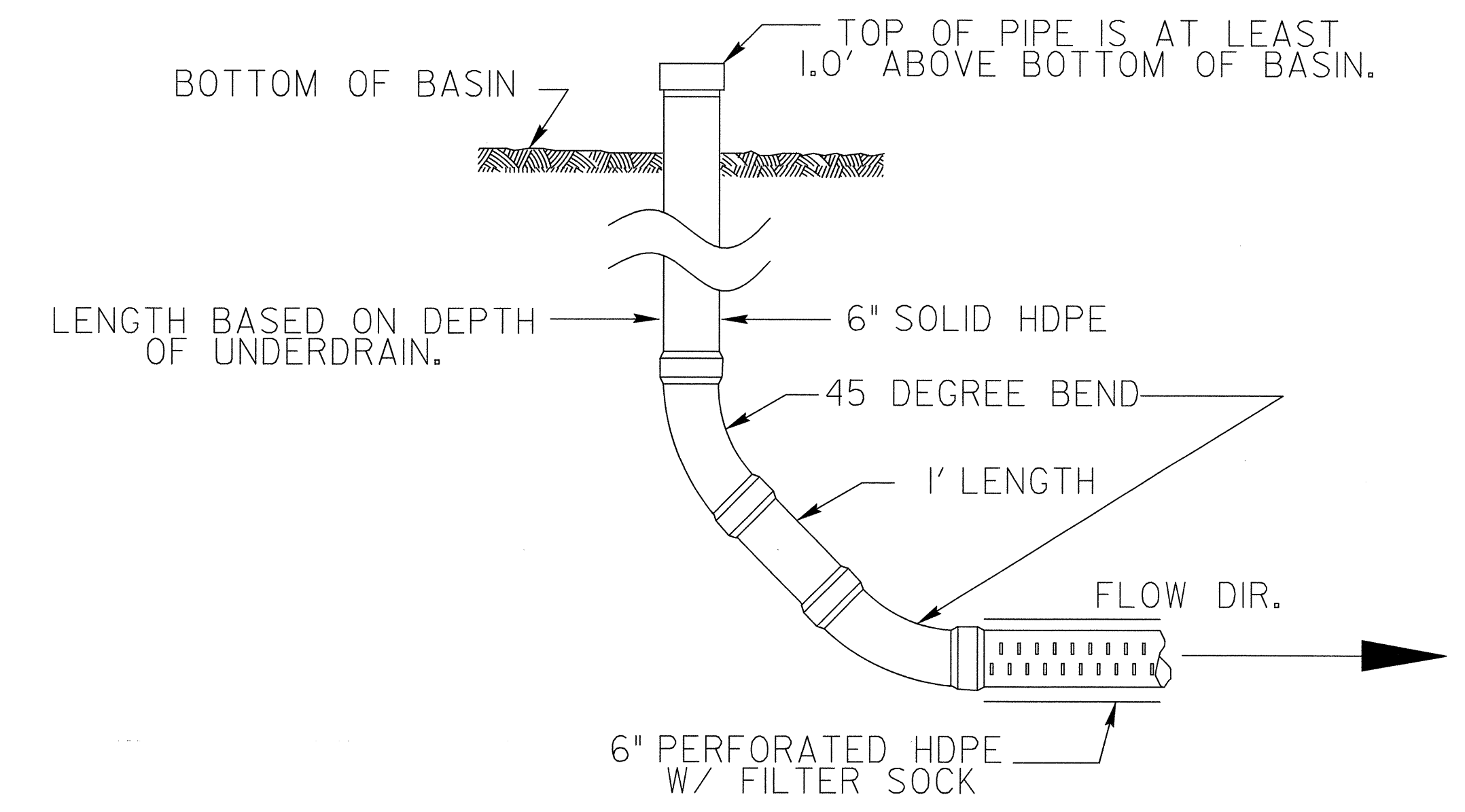

NOTE: ONLY UNDERDRAIN PIPE SHOULD BE PERFORATED

DRY DETENTION BASIN

"UNDERDRAIN SYSTEM"

*** NOT TO SCALE**

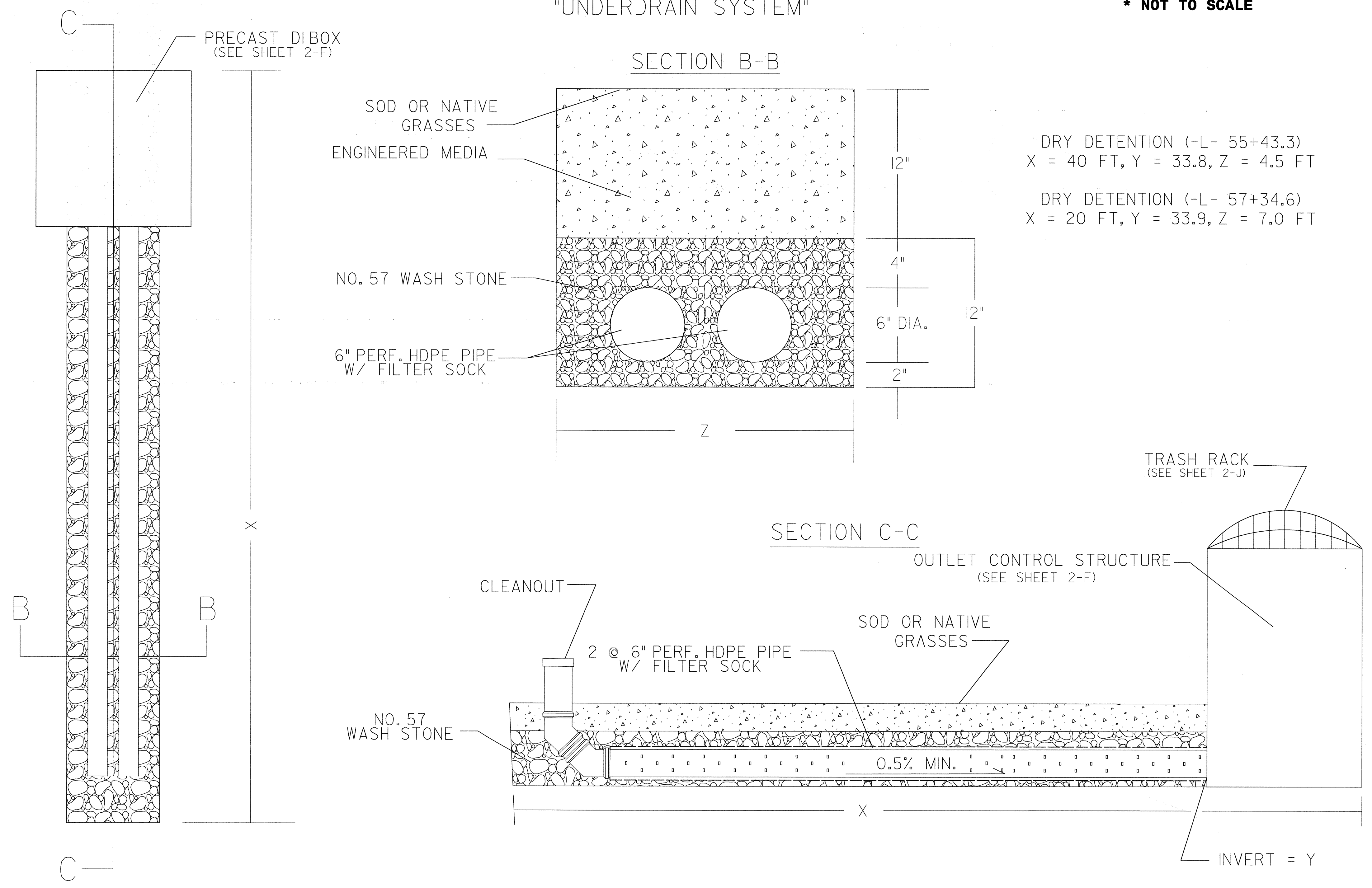

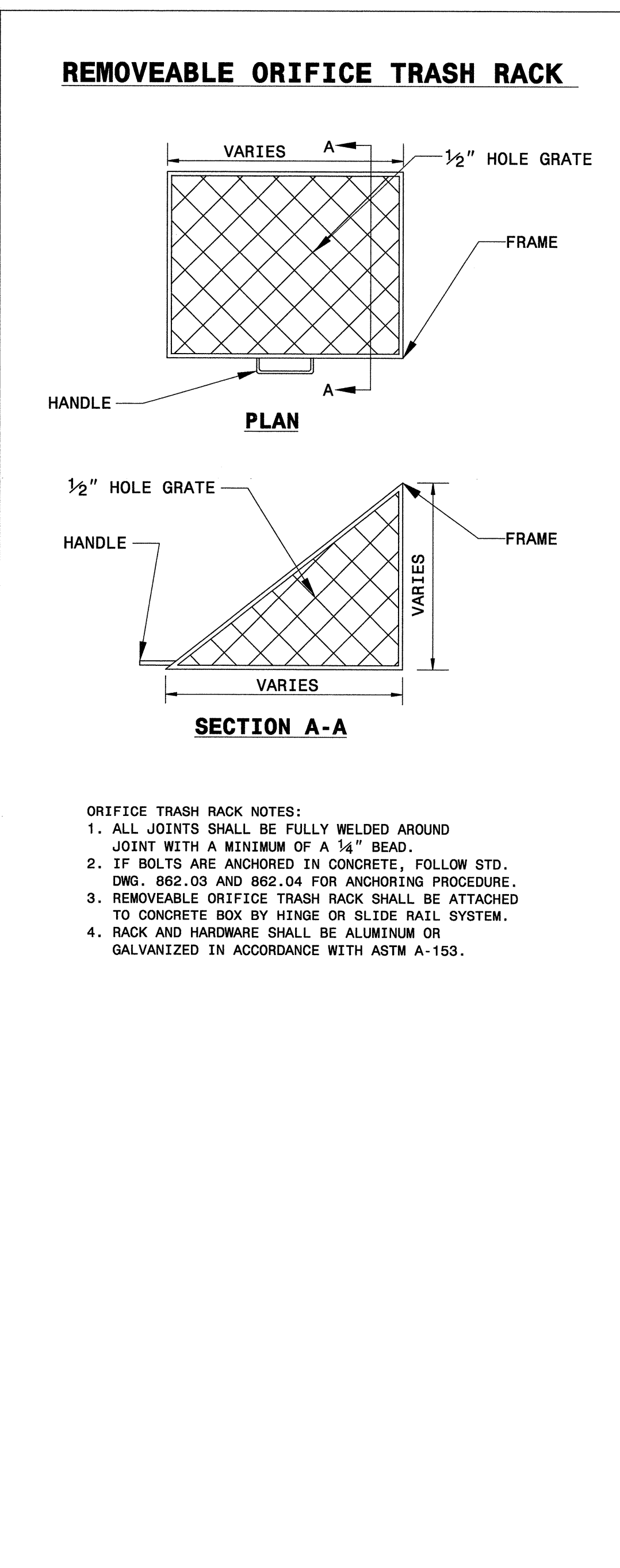
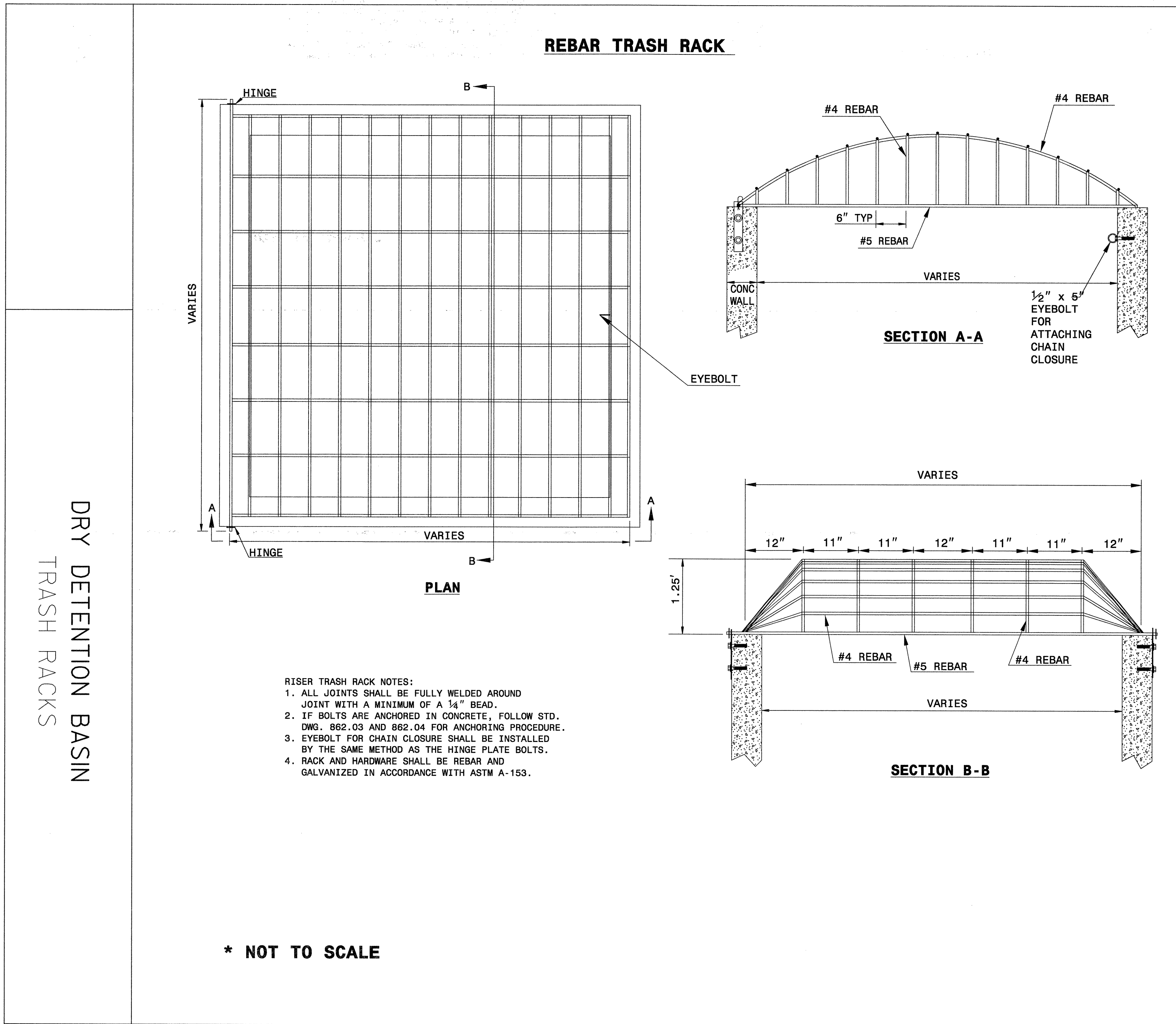

DRY DETENTION BASIN
TRASH RACKS

DRY DETENTION BASIN
TRASH RACKS

STATE OF NORTH CAROLINA DEPT. OF TRANSPORTATION DIVISION OF HIGHWAYS RALEIGH, N.C. 7-06

ENGLISH DETAIL DRAWING FOR METHOD OF PIPE INSTALLATION

FLEXIBLE PIPE

SHEET 1 OF 3 300D01

GENERAL NOTES:
 I.D. = THE MAXIMUM HORIZONTAL INSIDE DIAMETER DIMENSION.
 O.D. = THE MAXIMUM HORIZONTAL OUTSIDE DIAMETER DIMENSION.
 H = THE FILL HEIGHT MEASURED VERTICALLY AT ANY POINT ALONG THE PIPE FROM THE TOP OF THE PIPE TO THE TOP OF THE EMBANKMENT AT THAT POINT.

DO NOT OPERATE HEAVY EQUIPMENT OVER ANY PIPE CULVERT UNTIL THE PIPE CULVERT HAS BEEN PROPERLY BACKFILLED AND COVERED WITH AT LEAST 3 FEET OF APPROVED MATERIAL.

--- SPRINGLINE OF PIPE
 SELECT BACKFILL MATERIAL CLASS III OR CLASS II, TYPE 1 ABOVE AND BELOW SPRINGLINE.
 APPROVED SUITABLE LOCAL MATERIAL.

UNDISTURBED EARTH MATERIAL
 SELECT MATERIAL CLASS V OR VI FOR FOUNDATION CONDITIONING. ENCAPSULATE WITH ENGINEERING FABRIC AS DIRECTED BY THE ENGINEER.

TAKE CARE TO FULLY COMPACT HAUNCH ZONE OF PIPE BACKFILL.
 LOOSELY PLACED SELECT MATERIAL CLASS III OR CLASS II, TYPE 1 FOR PIPE BEDDING. LEAVE SECTION DIRECTLY BENEATH PIPE UNCOMPACTED AS PIPE SEATING AND BACKFILL WILL ACCOMPLISH COMPACTION.

STATE OF NORTH CAROLINA DEPT. OF TRANSPORTATION DIVISION OF HIGHWAYS RALEIGH, N.C. 7-06

ENGLISH DETAIL DRAWING FOR METHOD OF PIPE INSTALLATION

FLEXIBLE PIPE

SHEET 1 OF 3 300D01

STATE OF NORTH CAROLINA DEPT. OF TRANSPORTATION DIVISION OF HIGHWAYS RALEIGH, N.C. 7-06

ENGLISH DETAIL DRAWING FOR METHOD OF PIPE INSTALLATION

RIGID PIPE

SHEET 2 OF 3 300D01

GENERAL NOTES:
 I.D. = THE MAXIMUM HORIZONTAL INSIDE DIAMETER DIMENSION.
 O.D. = THE MAXIMUM HORIZONTAL OUTSIDE DIAMETER DIMENSION.
 H = THE FILL HEIGHT MEASURED VERTICALLY AT ANY POINT ALONG THE PIPE FROM THE TOP OF THE PIPE TO THE TOP OF THE EMBANKMENT AT THAT POINT.

DO NOT OPERATE HEAVY EQUIPMENT OVER ANY PIPE CULVERT UNTIL THE PIPE CULVERT HAS BEEN PROPERLY BACKFILLED AND COVERED WITH AT LEAST 3 FEET OF APPROVED MATERIAL.

--- SPRINGLINE OF PIPE
 SELECT BACKFILL MATERIAL CLASS III OR CLASS II, TYPE 1 BELOW SPRINGLINE.
 APPROVED SUITABLE LOCAL MATERIAL ABOVE SPRINGLINE.

UNDISTURBED EARTH MATERIAL
 SELECT MATERIAL CLASS V OR VI FOR FOUNDATION CONDITIONING. ENCAPSULATE WITH ENGINEERING FABRIC AS DIRECTED BY THE ENGINEER.

TAKE CARE TO FULLY COMPACT HAUNCH ZONE OF PIPE BACKFILL.
 LOOSELY PLACED SELECT MATERIAL CLASS III OR CLASS II, TYPE 1 FOR PIPE BEDDING. LEAVE SECTION DIRECTLY BENEATH PIPE UNCOMPACTED AS PIPE SEATING AND BACKFILL WILL ACCOMPLISH COMPACTION.

STATE OF NORTH CAROLINA DEPT. OF TRANSPORTATION DIVISION OF HIGHWAYS RALEIGH, N.C. 7-06

ENGLISH DETAIL DRAWING FOR METHOD OF PIPE INSTALLATION

RIGID PIPE

SHEET 2 OF 3 300D01

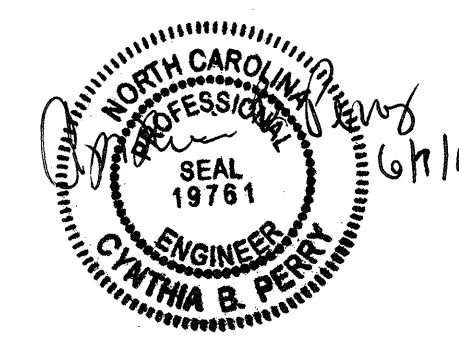

PROJECT SERVICES UNIT
 STANDARDS AND SPECIAL DESIGN
 Office 919-250-4128 FAX 919-250-4119

SEE PLATE FOR TITLE

ORIGINAL BY: Kkempf DATE: 5-15-09
 MODIFIED BY: DATE:
 CHECKED BY: DATE:
 FILE SPEC:\ericward\stds\stdsdetails\300d01\0300d01.dgn

STATE OF NORTH CAROLINA
 DEPT. OF TRANSPORTATION
 DIVISION OF HIGHWAYS
 RALEIGH, N.C.

7-06

ENGLISH DETAIL DRAWING FOR
METHOD OF PIPE INSTALLATION

FILL HEIGHT TABLES

SHEET 3 OF 3
300D01

FLEXIBLE PIPE

Diameter (inches)	Round Corrugated Steel Pipe 2 2/3 x 1/2 corrugation **			
	Minimum cover (inches)	(Ga)	16	14
12	12	204	256	204
15	12	162	204	162
18	12	135	169	239
21	12	115	145	204
24	12	100	126	178
30	12	79	100	142
36	12	65	83	117
42	12	55	70	100
48	12	48	61	87
54	12	48	54	77
60	12			69
66	12			90
72	12			81
78	12			74
84	12			69

Diameter (inches)	Round Corrugated Aluminum Pipe 2 2/3 x 1/2 corrugation **			
	Minimum cover (inches)	(Ga)	16	14
12	12	123	155	216
15	12	98	123	174
18	12	81	102	144
21	12	69	87	123
24	12	60	76	108
27	12	67	95	123
30	12	60	85	111
36	12	50	71	92
42	12	42	60	78
48	12	42	52	68
54	12	46	46	50
60	12			50
66	12			51
72	12			41

** FOR DIFFERENT CORRUGATIONS AND ARCH PIPES REFER TO ROADWAY DESIGN MANUAL OR MANUFACTURERS SPECIFICATION.

REFER TO THE FOLLOWING FOR PIPE SPECIFICATIONS

- CSP - AASHTO M36
- CAAP - AASHTO M196
- HDPE - AASHTO M294
- PVC - ASTM F949 or AASHTO M304

NOTES: FILL HEIGHTS SHOWN WERE CALCULATED USING AASHTO LRFD BRIDGE DESIGN SPECIFICATIONS

1' MINIMUM COVER FOR ALL SIDE DRAIN PIPE IN ACCORDANCE WITH THE STANDARD SPECIFICATIONS

RIGID PIPE

- RCP - * (Minimum fill) 1' for Class IV & CLASS V
 2' for Class III & Class II
- * (Maximum fill) 10' - Class II pipe
 20' - Class III pipe
 30' - Class IV pipe
 40' - Class V pipe

(For fills > 40' & < 80' use LRFD Direct Design Method)

* FILL HEIGHT IS MEASURED FROM THE TOP OF THE PIPE TO THE BOTTOM OF THE PAVEMENT STRUCTURE

REFER TO THE FOLLOWING FOR PIPE SPECIFICATIONS

- RCP - AASHTO M170

NOTES: FILL HEIGHTS SHOWN WERE CALCULATED USING AASHTO LRFD BRIDGE DESIGN SPECIFICATIONS

1' MINIMUM COVER FOR ALL SIDE DRAIN PIPE IN ACCORDANCE WITH THE STANDARD SPECIFICATIONS

STATE OF NORTH CAROLINA
 DEPT. OF TRANSPORTATION
 DIVISION OF HIGHWAYS
 RALEIGH, N.C.

7-06

ENGLISH DETAIL DRAWING FOR
METHOD OF PIPE INSTALLATION

FILL HEIGHT TABLES

SHEET 3 OF 3
300D01

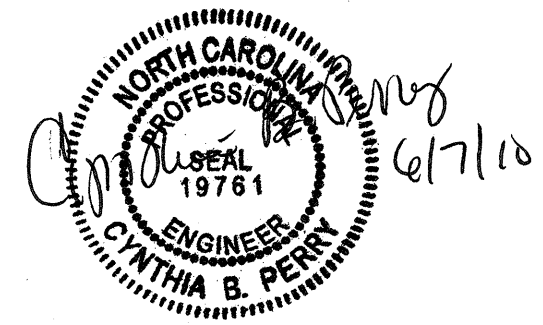

PROJECT SERVICES UNIT
 STANDARDS AND SPECIAL DESIGN
 Office 919-250-4128 FAX 919-250-4119

SEE PLATE FOR TITLE

ORIGINAL BY: KKempf DATE: 5-15-09
 MODIFIED BY: DATE:
 CHECKED BY: DATE:
 FILE SPEC:\ericward\stds\stdstodetails\30001\0300d01.dgn

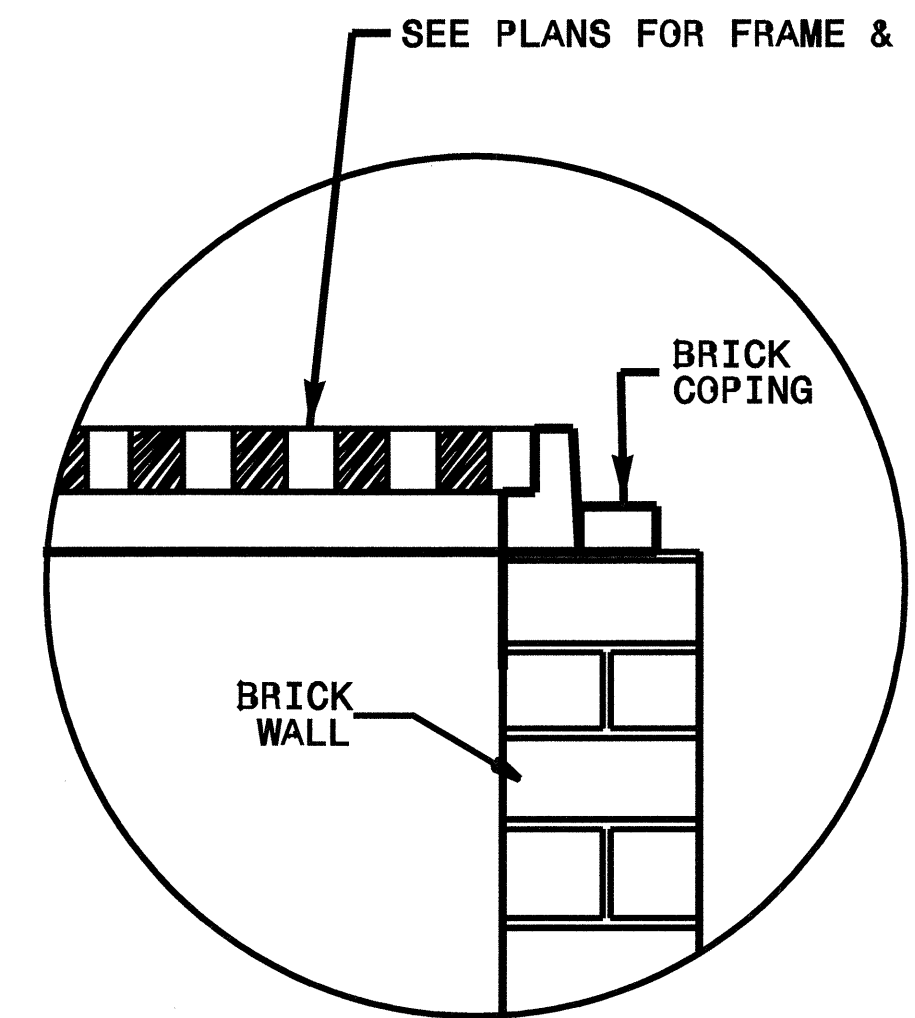

GRATE PLACEMENT DETAIL
FOR DROP INLETS

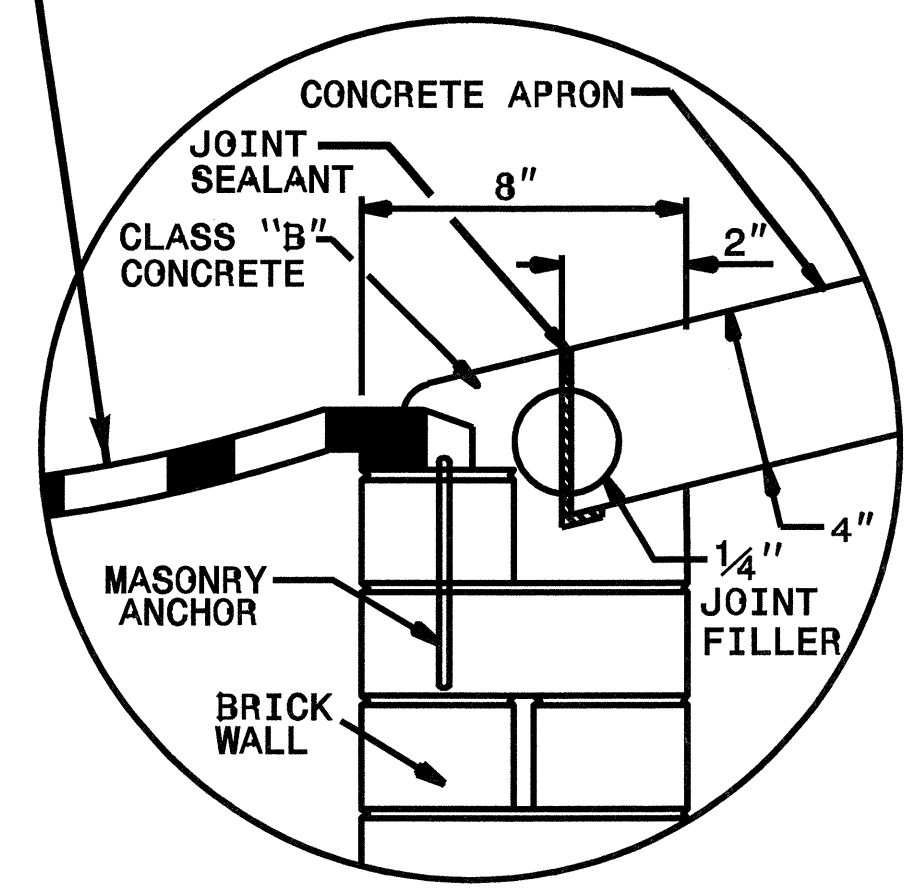

GRATE PLACEMENT DETAIL
FOR GRATED DROP INLETS

GENERAL NOTES:

- CONSTRUCT IN ACCORDANCE WITH SECTION 859 OF THE STANDARD SPECIFICATIONS.
- USE CLASS B CONCRETE.
- THE DIMENSIONS FOR THE EXISTING BOXES ARE APPROXIMATE AND MAY VARY SLIGHTLY.
- JUMBO CONCRETE BRICK WILL BE PERMITTED. 4" CONCRETE BRICK OR 8" SOLID CONCRETE BLOCK ARE REQUIRED FOR DRAINAGE STRUCTURE.
- INCLUDE 18" CONCRETE APRON IN UNIT PRICE BID PER EACH, CONVERT EXISTING CATCH BASIN TO DROP INLET.
- SPECIAL DESIGN IS REQUIRED FOR USE UNDER PAVEMENT.
- CONFIRM DIMENSIONS ON EACH INDIVIDUAL FRAME & GRATE PROPOSAL.
- SEE STD. DRAWING 840.25 FOR MASONRY ANCHORAGE.

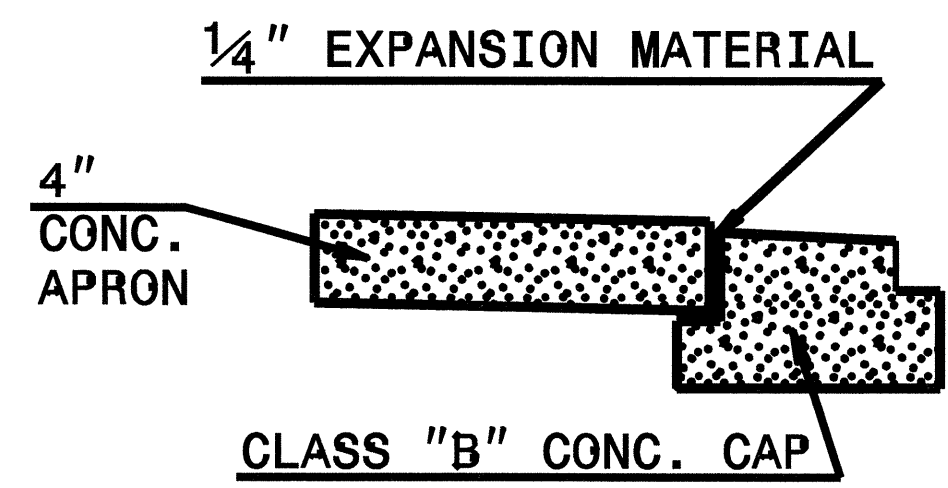
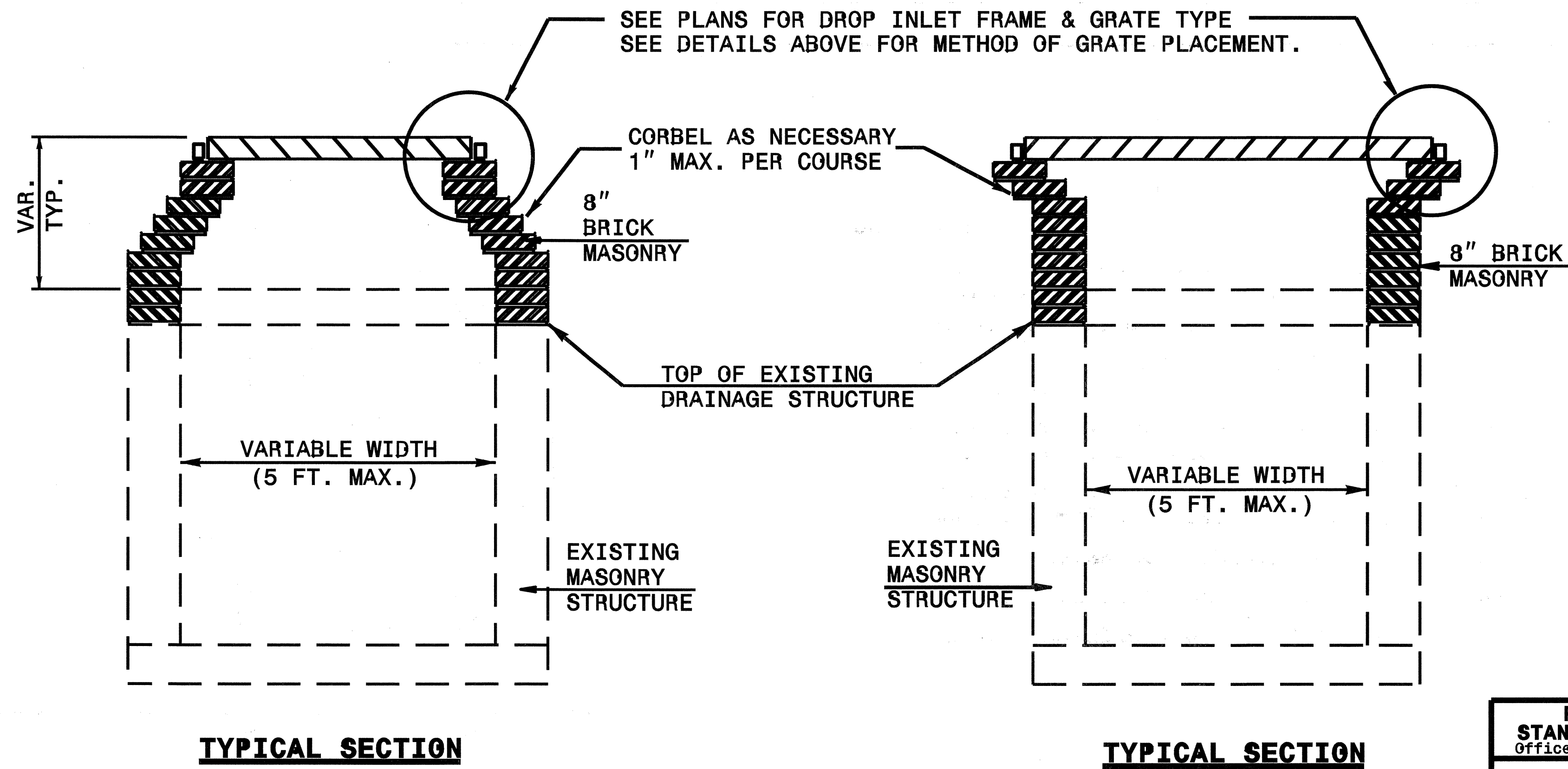

EXPANSION JOINT DETAIL

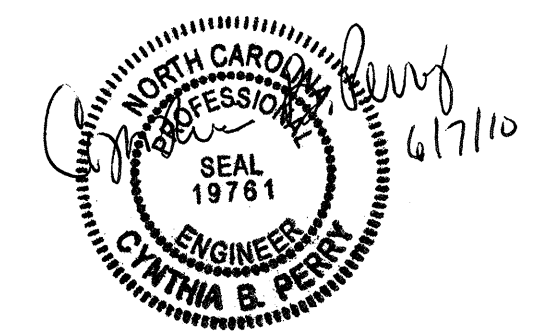

**PROJECT SERVICES UNIT
STANDARDS AND SPECIAL DESIGN**
Office 919-250-4128 FAX 919-250-4119

**DETAIL TO CONVERT
EXISTING CATCH BASIN OR
JUNCTION BOX TO DROP INLET**

ORIGINAL BY: T.S.E.	DATE: NOV. 1997
MODIFIED BY: T.S.E.	DATE: FEB. 2000
CHECKED BY:	DATE:
FILE SPEC.: s:\usr\details\stand\cbstd102.dgn	

25-MAY-2010 10:30
 S:\Contracts\Comp\255756\Special_Details\tspe11\details\stand\cbstd102.dgn
 J:\homer\con - AT P523756

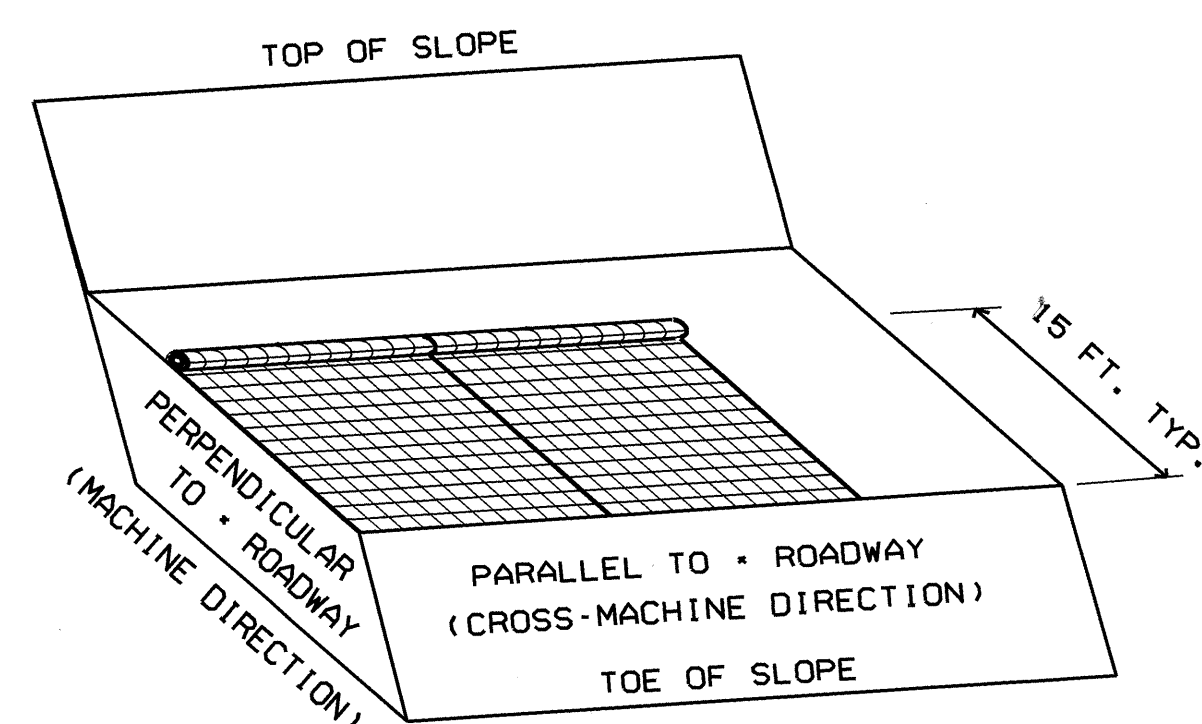

15 FT. LONG (PRIMARY) GEOGRID REINFORCEMENT DETAIL

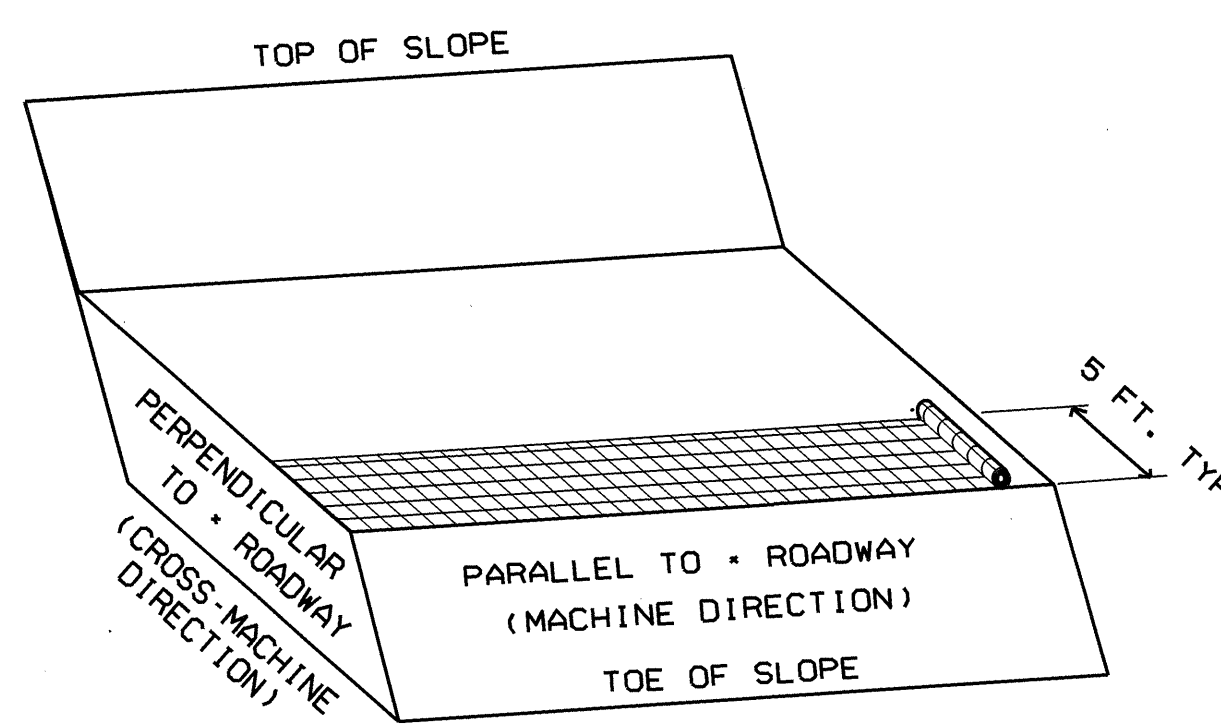

5 FT. WIDE (SECONDARY) GEOGRID REINFORCEMENT DETAIL

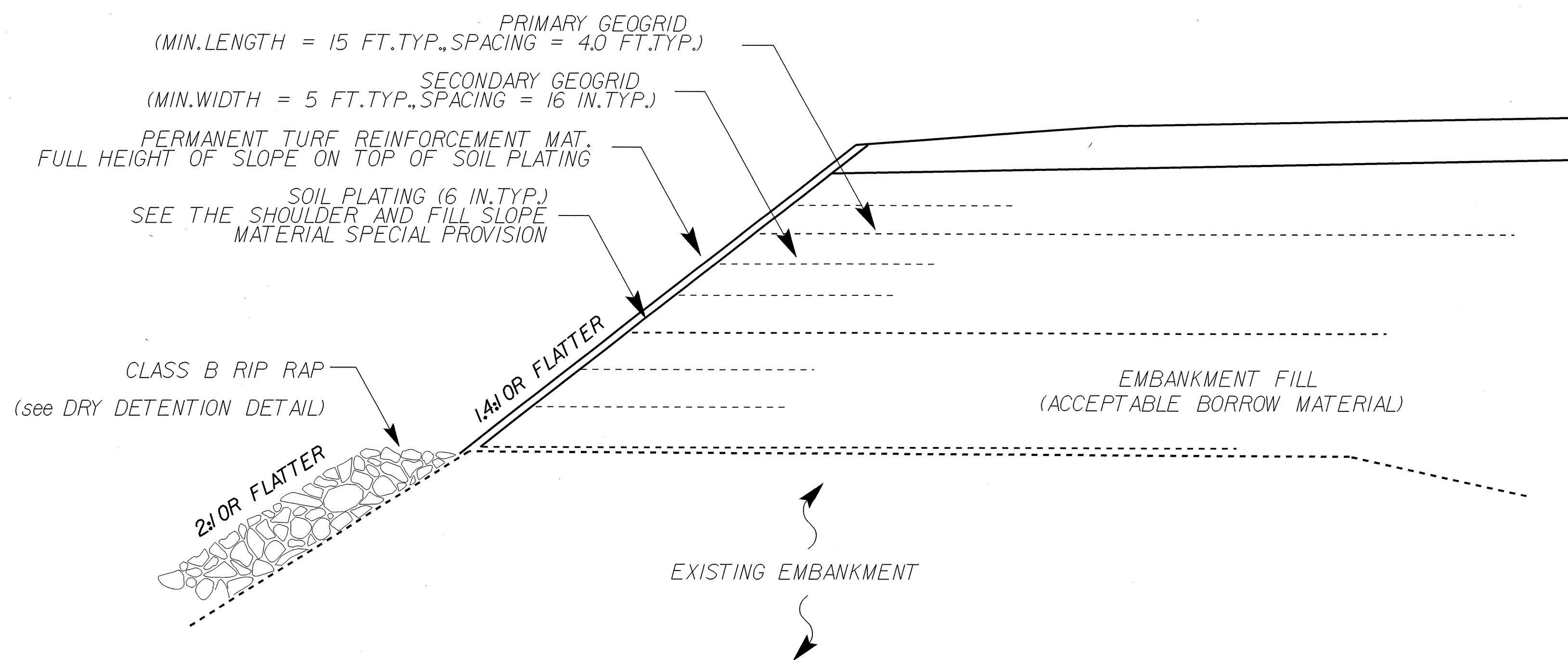

GEOGRID REINFORCED SLOPE TYPICAL SECTION
N.T.S

NOTES:

- GEOGRID REINFORCEMENT SHALL BE PLACED AT THE LOCATIONS LISTED IN THE GEOGRID REINFORCED SLOPE TABLE WHERE SLOPES ARE STEEPER THAN 2.5:1 (H:V).
- LAYERS OF REINFORCEMENT MAY NEED TO BE ADDED OR SUBTRACTED AT THE TOP OF SLOPE AS THE EMBANKMENT HEIGHT VARIES THROUGH THE STEEPENED SECTION.
- THE TOP LAYER OF REINFORCEMENT MAY BE LOWERED SLIGHTLY IF NECESSARY TO PREVENT INTERFERENCE WITH THE SUBGRADE.
- THE FIRST LAYER OF GEOGRID SHALL BE PLACED ON LEVEL GROUND NOT STEEPER THAN 5% GRADE.
- SEE THE SPECIAL PROVISION FOR GEOGRID REINFORCEMENT FOR DETAILED REQUIREMENTS OF MATERIALS AND CONSTRUCTION.
- PERMANENT TURF REINFORCEMENT MATTING SHALL BE PLACED AT THE LOCATIONS LISTED IN THE SLOPE TABLE WHERE SLOPES ARE STEEPER THAN 2.5:1 (H:V).
- BACKFILL WITHIN THE REINFORCED VOLUME SHALL BE COASTAL PLAIN BORROW MATERIAL IN ACCORDANCE WITH SECTION 1018 OF THE STANDARD SPECIFICATIONS.
- PLATE THE FACE OF THE SLOPE WITH 6 INCHES OF SOIL IN ACCORDANCE WITH THE SHOULDER AND FILL SLOPE MATERIAL SPECIAL PROVISION.
- THE ENTIRE EMBANKMENT SHALL BE CONSTRUCTED SIMULTANEOUSLY WITH THE SLOPE REINFORCEMENT.

Geogrid Reinforced Slope Table			
Alignment	Begin Station	End Station	Location
-L-	53+75 +/-	55+44 +/-	Left
-L-	57+26 +/-	58+25 +/-	Left

REINFORCED SLOPE ESTIMATED QUANTITIES:

PRIMARY GEOGRID REINFORCEMENT: 1420 SQ. YD.
SECONDARY GEOGRID REINFORCEMENT: 520 SQ. YD.
PERMANENT TURF REINFORCEMENT MAT: 380 SQ. YD.

PREPARED BY: JYP DATE: 08/2009
REVIEWED BY: JRB DATE: 08/2009

GEOTECHNICAL ENGINEERING UNIT

EASTERN REGIONAL OFFICE
 WESTERN REGIONAL OFFICE
 CONTRACT OFFICE

STATE OF NORTH CAROLINA
DEPARTMENT OF TRANSPORTATION
RALEIGH



GEOGRID REINFORCED SLOPE DETAIL

REVISIONS					
NO.	BY	DATE	NO.	BY	DATE
1	-	-	3	-	-
2	-	-	4	-	-

STATE OF NORTH CAROLINA
DIVISION OF HIGHWAYS
ROADWAY SUMMARY OF QUANTITIES FOR CONTRACT - C201904

ItemNumber	Sec #	Quantity	Unit	Description	ItemNumber	Sec #	Quantity	Unit	Description	ItemNumber	Sec #	Quantity	Unit	Description	ItemNumber	Sec #	Quantity	Unit	Description
0000100000-N	800	Lump Sum		MOBILIZATION	2366000000-N	840	5	EA	FRAME WITH TWO GRATES, STD 840.24	4850000000-E	1205	805	LF	REMOVAL OF PAVEMENT MARKING LINES (4")	6087000000-E	1660	1	ACR	MOWING
0000400000-N	801	Lump Sum		CONSTRUCTION SURVEYING	2367000000-N	840	3	EA	FRAME WITH TWO GRATES, STD 840.29	4860000000-E	1205	1,038	LF	REMOVAL OF PAVEMENT MARKING LINES (8")	6090000000-E	1661	50	LB	SEED FOR REPAIR SEEDING
0029000000-N	SP	Lump Sum		REINFORCED BRIDGE APPROACH FILL, STATION ***** (56+12.00-L-)	2374000000-N	840	2	EA	FRAME WITH GRATE & HOOD, STD 840.03, TYPE ** (E)	4875000000-N	1205	9	EA	REMOVAL OF PAVEMENT MARKING SYMBOLS & CHARACTERS	6093000000-E	1661	0.25	TON	FERTILIZER FOR REPAIR SEEDING
0036000000-E	225	30,250	CY	UNDERCUT EXCAVATION	2374000000-N	840	3	EA	FRAME WITH GRATE & HOOD, STD 840.03, TYPE ** (F)	4900000000-N	1251	261	EA	PERMANENT RAISED PAVEMENT MARKERS	6096000000-E	1662	50	LB	SEED FOR SUPPLEMENTAL SEEDING
0038000000-E	SP	150	CY	SHALLOW UNDERCUT	2396000000-N	840	2	EA	FRAME WITH COVER, STD 840.54	5326000000-E	1510	62	LF	6" WATER LINE	6108000000-E	1665	1.25	TON	FERTILIZER TOPDRESSING
0043000000-N	226	Lump Sum		GRADING	2451000000-N	852	14	EA	CONCRETE TRANSITIONAL SECTION FOR DROP INLETS	5326000000-E	1510	4,539	LF	12" WATER LINE	6110000000-E	SP	100	LF	IMPERVIOUS DIKE
0050000000-E	226	1	ACR	SUPPLEMENTARY CLEARING & GRUB-BING	2473000000-N	SP	4	EA	GENERIC DRAINAGE ITEM NARROW DROP INLET FRAME AND GRATE	5538000000-E	1515	1	EA	4" VALVE	6114000000-N	SP	2	HR	SPECIALIZED HAND MOWING
0080000000-E	SP	250	TON	CLASS IV SUBGRADE STABILIZATION	2473000000-N	SP	4	EA	GENERIC DRAINAGE ITEM DRY DETENTION BASIN STA 55+43.3	5540000000-E	1515	2	EA	6" VALVE	6117000000-N	SP	8	EA	RESPONSE FOR EROSION CONTROL
0106000000-E	230	16,300	CY	BORROW EXCAVATION	2473000000-N	SP	Lump Sum		GENERIC DRAINAGE ITEM DRY DETENTION BASIN STA 57+34.6	5546000000-E	1515	1	EA	8" VALVE	6123000000-E	1670	0.5	ACR	REFORESTATION
0134000000-E	240	5,205	CY	DRAINAGE DITCH EXCAVATION	2473000000-N	SP	Lump Sum		GENERIC DRAINAGE ITEM DRY DETENTION BASIN STA 57+34.6	5552000000-E	1515	1	EA	10" VALVE	6126000000-E	SP	0.5	ACR	STREAMBANK REFORESTATION
0194000000-E	SP	30,650	CY	SELECT GRANULAR MATERIAL, CLASS III	2542000000-E	846	6,000	LF	1'-6" CONCRETE CURB & GUTTER	5558000000-E	1515	8	EA	12" VALVE					
0196000000-E	270	30,650	SY	FABRIC FOR SOIL STABILIZATION	2549000000-E	846	790	LF	2'-6" CONCRETE CURB & GUTTER	5572000000-E	1515	1	EA	8" TAPPING VALVE					
0241000000-E	SP	380	SY	GENERIC GRADING ITEM PERMANENT TURF REINFORCEMENT MAT	2577000000-E	846	475	LF	CONCRETE EXPRESSWAY GUTTER	5572000000-E	1515	1	EA	12" TAPPING VALVE					
0241000000-E	SP	1,420	SY	GENERIC GRADING ITEM PRIMARY GEOGRID REINFORCEMENT	2612000000-E	848	264	SY	6" CONCRETE DRIVEWAY	5588000000-E	1515	3	EA	** AIR RELEASE VALVE (10")					
0241000000-E	SP	520	SY	GENERIC GRADING ITEM SECONDARY GEOGRID REINFORCEMENT	2647000000-E	852	70	SY	5" MONOLITHIC CONCRETE ISLANDS (SURFACE MOUNTED)	5666000000-E	1515	3	EA	FIRE HYDRANT					
0318000000-E	SP	310	TON	FOUNDATION CONDITIONING MATERIAL, MINOR STRS	2655000000-E	852	440	SY	5" MONOLITHIC CONCRETE ISLANDS (KEYED IN)	5672000000-N	1515	1	EA	RELOCATE FIRE HYDRANT					
0320000000-E	SP	960	SY	FOUNDATION CONDITIONING FABRIC	2739000000-E	852	280	SY	GENERIC PAVING ITEM 5" MONOLITHIC CONCRETE ISLAND (KEYED IN-MODIFIED)	5709300000-E	1520	98	LF	6" FORCE MAIN SEWER					
0335200000-E	SP	464	LF	15" DRAINAGE PIPE	2739000000-E	852	280	SY	GENERIC PAVING ITEM 5" MONOLITHIC CONCRETE ISLAND (KEYED IN-MODIFIED)	5709500000-E	1520	4,651	LF	10" FORCE MAIN SEWER					
0335300000-E	SP	240	LF	18" DRAINAGE PIPE	2950000000-N	SP	2	EA	CONVERT EXISTING JUNCTION BOX TO DROP INLET	5776000000-E	1525	4	EA	5" DIA UTILITY MANHOLE					
0335400000-E	SP	8	LF	24" DRAINAGE PIPE	3030000000-E	862	425	LF	STEEL BM GUARDRAIL	5798000000-E	1530	5,090	LF	ABANDON *** UTILITY PIPE (4")					
0335850000-E	SP	4	EA	*** DRAINAGE PIPE ELBOWS (15")	3150000000-N	862	5	EA	ADDITIONAL GUARDRAIL POSTS	5800000000-E	1530	3,988	LF	ABANDON 6" UTILITY PIPE					
0335850000-E	SP	2	EA	*** DRAINAGE PIPE ELBOWS (18")	3210000000-N	862	1	EA	GUARDRAIL ANCHOR UNITS, TYPE CAT-1	5801000000-E	1530	30	LF	ABANDON 8" UTILITY PIPE					
0343000000-E	SP	180	LF	15" SIDE DRAIN PIPE	3210000000-N	862	1	EA	GUARDRAIL ANCHOR UNITS, TYPE CAT-1	5802000000-E	1530	4,675	LF	ABANDON 10" UTILITY PIPE					
0344000000-E	SP	128	LF	18" SIDE DRAIN PIPE	3270000000-N	SP	2	EA	GUARDRAIL ANCHOR UNITS, TYPE III	5804000000-E	1530	4,584	LF	ABANDON 12" UTILITY PIPE					
0448200000-E	SP	1,764	LF	15" RC PIPE CULVERTS, CLASS IV	3270000000-N	SP	2	EA	GUARDRAIL ANCHOR UNITS, TYPE 350	5828000000-N	1530	2	EA	REMOVE UTILITY MANHOLE					
0448400000-E	SP	96	LF	24" RC PIPE CULVERTS, CLASS IV	3628000000-E	876	105	TON	RIP RAP, CLASS I	5871400000-E	1550	400	LF	TRENCHLESS INSTALLATION OF 6" IN SOIL					
0986000000-E	SP	12	LF	GENERIC PIPE ITEM 6" HDPE PIPE	3649000000-E	876	13	TON	RIP RAP, CLASS B	5871700000-E	1550	400	LF	TRENCHLESS INSTALLATION OF 12" IN SOIL					
0986000000-E	SP	92	LF	GENERIC PIPE ITEM 6" PERFORATED HDPE PIPE	3656000000-E	876	192	SY	FILTER FABRIC FOR DRAINAGE	5871800000-E	1550	400	LF	TRENCHLESS INSTALLATION OF 14" IN SOIL					
0992000000-E	SP	2	EA	GENERIC PIPE ITEM 6" HDPE CAPS	3659000000-N	SP	1	EA	PREFORMED SCOUR HOLES WITH LEVEL SPREADER APRON	5879400000-E	SP	137	LF	2" GAS LINE					
0992000000-E	SP	4	EA	GENERIC PIPE ITEM 6" HDPE ELBOWS	4400000000-E	1110	354	SF	WORK ZONE SIGNS (STATIONARY)	5879600000-E	SP	4,931	LF	4" GAS LINE					
0995000000-E	340	523	LF	PIPE REMOVAL	4405000000-E	1110	192	SF	WORK ZONE SIGNS (PORTABLE)	5880400000-E	SP	1	EA	4" GAS VALVE					
1121000000-E	520	1,660	TON	AGGREGATE BASE COURSE	4410000000-E	1110	100	SF	WORK ZONE SIGNS (BARRICADE MOUNTED)	5882000000-N	SP	1	EA	6" GAS VALVE					
1220000000-E	545	1,000	TON	INCIDENTAL STONE BASE	4430000000-N	1130	175	EA	DRUMS	5882000000-N	SP	9	EA	GENERIC UTILITY ITEM RECONNECT 3/4" GAS SERVICE					
1491000000-E	610	15,335	TON	ASPHALT CONC BASE COURSE, TYPE B25.0C	4450000000-N	1150	540	MD	FLAGGER	5882000000-N	SP	17	EA	GENERIC UTILITY ITEM RELOCATE EXISTING WATER METER					
1503000000-E	610	8,310	TON	ASPHALT CONC INTERMEDIATE COURSE, TYPE I19.0C	4465000000-N	1160	2	EA	TEMPORARY CRASH CUSHIONS	6000000000-E	1605	3,480	LF	TEMPORARY SILT FENCE					
1523000000-E	610	6,100	TON	ASPHALT CONC SURFACE COURSE, TYPE S9.5C	4485000000-E	1170	500	LF	PORTABLE CONCRETE BARRIER	6006000000-E	1610	50	TON	STONE FOR EROSION CONTROL, CLASS A					
1560000000-E	620	1,050	TON	ASPHALT BINDER FOR PLANT MIX, GRADE PG 64-22	4650000000-N	1251	113	EA	TEMPORARY RAISED PAVEMENT MARKERS	6009000000-E	1610	190	TON	STONE FOR EROSION CONTROL, CLASS B					
1565000000-E	620	366	TON	ASPHALT BINDER FOR PLANT MIX, GRADE PG 70-22	4685000000-E	1205	9,560	LF	THERMOPLASTIC PAVEMENT MARKING LINES (4", 90 MILS)	6012000000-E	1610	190	TON	SEDIMENT CONTROL STONE					
1693000000-E	654	50	TON	ASPHALT PLANT MIX, PAVEMENT REPAIR	4686000000-E	1205	5,474	LF	THERMOPLASTIC PAVEMENT MARKING LINES (4", 120 MILS)	6015000000-E	1615	2	ACR	TEMPORARY MULCHING					
2022000000-E	SP	1,092	CY	SUBDRAIN EXCAVATION	4710000000-E	1205	76	LF	THERMOPLASTIC PAVEMENT MARKING LINES (24", 120 MILS)	6018000000-E	1620	100	LB	SEED FOR TEMPORARY SEEDING					
2033000000-E	SP	546	CY	SUBDRAIN FINE AGGREGATE	4721000000-E	1205	8	EA	THERMOPLASTIC PAVEMENT MARKING CHARACTER (120 MILS)	6021000000-E	1620	0.25	TON	FERTILIZER FOR TEMPORARY SEEDING					
2044000000-E	SP	3,250	LF	6" PERFORATED SUBDRAIN PIPE	4725000000-E	1205	27	EA	THERMOPLASTIC PAVEMENT MARKING SYMBOL (90 MILS)	6029000000-E	SP	800	LF	SAFETY FENCE					
2070000000-N	SP	7	EA	SUBDRAIN PIPE OUTLETS	4770000000-E	1205	1,266	LF	COLD APPLIED PLASTIC PAVEMENT MARKING LINES, TYPE ** (4") (IV)	6030000000-E	1630	645	CY	SILT EXCAVATION					
2077000000-E	SP	42	LF	6" OUTLET PIPE (SUBDRAINS)	4810000000-E	1205	67,025	LF	PAINT PAVEMENT MARKING LINES (4")	6036000000-E	1631	15,890	SY	MATting FOR EROSION CONTROL					
2253000000-E	840	1.3	CY	PIPE COLLARS	4820000000-E	1205	436	LF	PAINT PAVEMENT MARKING LINES (8")	6038000000-E	SP	1,470	SY	PERMANENT SOIL REINFORCEMENT MAT					
2275000000-E	SP	3.5	CY	FLOWABLE FILL	4835000000-E	1205	80	LF	PAINT PAVEMENT MARKING LINES (24")	6042000000-E	1632	580	LF	1/4" HARDWARE CLOTH					
2286000000-N	840	30	EA	MASONRY DRAINAGE STRUCTURES	4845000000-N	1205	10	EA	PAINT PAVEMENT MARKING SYMBOL	6045000000-E	SP	160	LF	*** TEMPORARY PIPE (18")					
2308000000-E	840	6.6	LF	MASONRY DRAINAGE STRUCTURES						6070000000-N	SP	1	EA	SPECIAL STILLING BASINS					
2364000000-N	840	8	EA	FRAME WITH TWO GRATES, STD 840.16						6084000000-E	1660	1.5	ACR	SEEDING & MULCHING					

8/17/99
B:\5200\cgy\p\o\U5018A\U-5018A_rdy_sum.dgn
8/17/99 8:33:56 AM

4/04/06

COMPUTED BY: FJJ DATE: 4-29-10
CHECKED BY: KBA DATE: 4-30-10

PROJECT REFERENCE NO. U-5018A
SHEET NO. 3-C

STATE OF NORTH CAROLINA
DIVISION OF HIGHWAYS

SUB-REGIONAL & REGIONAL
LIST OF PIPES, ENDWALLS, ETC. (FOR PIPES 48" & UNDER)

NOTE: INVERT ELEVATIONS INDICATED ARE FOR BID PURPOSES ONLY AND SHALL NOT BE USED FOR PROJECT CONSTRUCTION'S STAKEOUT. SEE STANDARD SPECIFICATIONS FOR ROADS AND STRUCTURES, SECTION 300-5."

Main data table with columns for Station, Location, Structure No., Top Elevation, Invert Elevation, Slope, Drainage Pipe, C.S. Pipe, R.C. Pipe, Endwalls, Quantities, Frame, Grates, Concrete Transitional Section, and Remarks.

ABBREVIATIONS table listing symbols for C.B., N.D.I., D.I., G.D.I., G.D.I. (N.S.), J.B., M.H., T.B.D.I., T.B.J.B., CATCH BASIN, NARROW DROP INLET, DROP INLET, GRATED DROP INLET (NARROW SLOT), JUNCTION BOX, MANHOLE, TRAFFIC BEARING DROP INLET, TRAFFIC BEARING JUNCTION, etc.

6/7/2010
R:\Roadway\Projects\U-5018A-U-5018A-r.dwg.sum.dgn

DIVISION OF HIGHWAYS
STATE OF NORTH CAROLINA



PARCEL INDEX SHEET

PARCEL NO.	SHEET NO.	PROPERTY OWNERS NAME
1	4	LIBERTY FREE WILL BAPTIST CHURCH
2	4	PAMELA T. FINCH
3	4	JOSEPH DANIEL JOYNER
4	4	KENNETH EARL VANDERBURG
5	4	ALICIA PASCASIO
6	5	KENNETH EARL VANDERBURG
7	5	LEDYARD ROSS
8	4	ALDINE K. GUTHRIE
9	4	FREDRICK DOUGLAS
10	4	FREDRICK DOUGLAS
11	4	MAE TUCKER
12	5	DOROTHY FOELL
13	5	RUEL S. STANCILL
14	5	BARNHILL CONTRACTING COMPANY
15	5	BARNHILL CONTRACTING COMPANY
16	4,5	KENNETH EARL VANDERBURG
17	5	TRACY T. LUPTON
18	5	NF MELVIN RAY SUGG & R. GUY MAYO, JR.
19	5	NF MELVIN RAY SUGG & R. GUY MAYO, JR.
20	5	HELEN M. WEAVER

PARCEL NO.	SHEET NO.	PROPERTY OWNERS NAME
21	5, 6	MILL RU HOMEOWNERS' ASSOCIATION
22	6	JANE C. ROSE
23	6	JULIAN W. RAWL
24	6	JULIAN W. RAWL
25	6	JULIAN W. RAWL
26	7	JULIAN W. RAWL
27	6,7	THOMAS ANDERSON
28	7	MARION ERNEST TAYLOR MOSIER
29	7	MARION ERNEST TAYLOR MOSIER
30	7	DOROTHY N. SATTERFIELD
32	6	FRANCES S. GOLD
33	8	FMM PARTNERSHIP
35	7,8	THE COVINGTON GROUP, LTD

5/28/99



PROJECT REFERENCE NO. U-5018A		SHEET NO. 4	
ROADWAY DESIGN ENGINEER NORTH CAROLINA PROFESSIONAL SEAL 17265 STEVE ANTHONY TRUIM 6/3/10		HYDRAULICS ENGINEER NORTH CAROLINA PROFESSIONAL SEAL 31977 IRVING B. ALFORD 6-3-10	
FOR -L- PROFILE SEE SHEET 9			

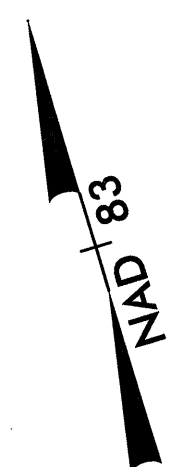

REVISIONS

-L- POT Sta. 10+00.00

BEGIN PROJECT U-5018A
-L- POT Sta. 12+25.00
BEGIN CONSTRUCTION

15+00

20+00

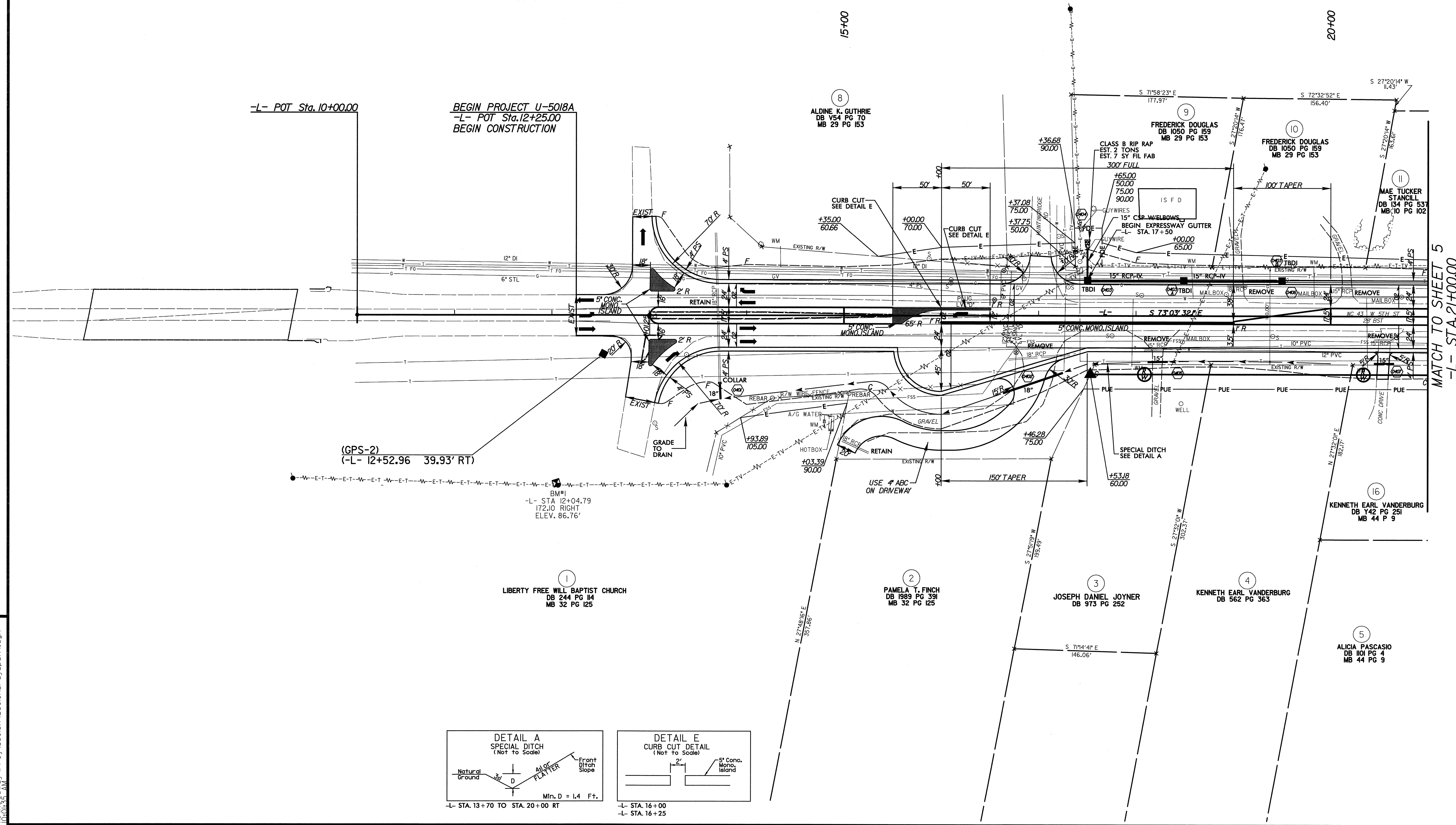

MATCH TO SHEET 5
-L- STA. 21+00.00

(GPS-2)
(-L- 12+52.96 39.93' RT)

1
LIBERTY FREE WILL BAPTIST CHURCH
DB 244 PG 114
MB 32 PG 125

2
PAMELA T. FINCH
DB 1889 PG 391
MB 32 PG 125

3
JOSEPH DANIEL JOYNER
DB 973 PG 252

4
KENNETH EARL VANDERBURG
DB 562 PG 363

16
KENNETH EARL VANDERBURG
DB Y42 PG 251
MB 44 P 9

5
ALICIA PASCASIO
DB 101 PG 4
MB 44 PG 9

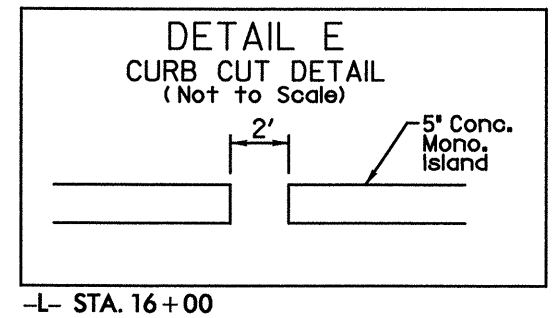
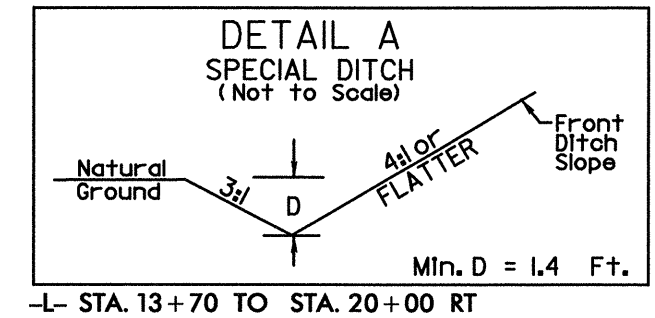

5/28/2010
P:\Projects\U5018A\U5018A.rdy_psh4.dgn

5/28/99

-L-
 PI Sta 25+93.23
 $\Delta = 13' 06'' 37.8'' (RT)$
 $D = 4' 08'' 15.5''$
 $L = 316.86'$
 $T = 159.12'$
 $R = 1,384.74'$
 $SE = 04'$
 $RO = 144'$

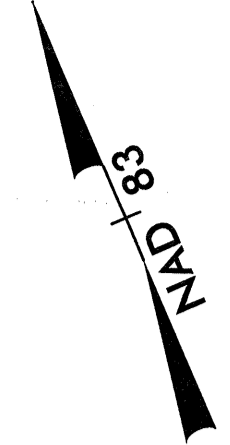

MULKEY
 ENGINEERS & CONSULTANTS
 1010 S. 11th St.
 Raleigh, N.C. 27603
 (919) 851-1912
 (919) 851-1918 FAX
 WWW.MULKEYINC.COM

PROJECT REFERENCE NO. U-5018A		SHEET NO. 5	
ROADWAY DESIGN ENGINEER		HYDRAULICS ENGINEER	
6/3/10		6-3-10	
FOR -L- PROFILE SEE SHEET 9			

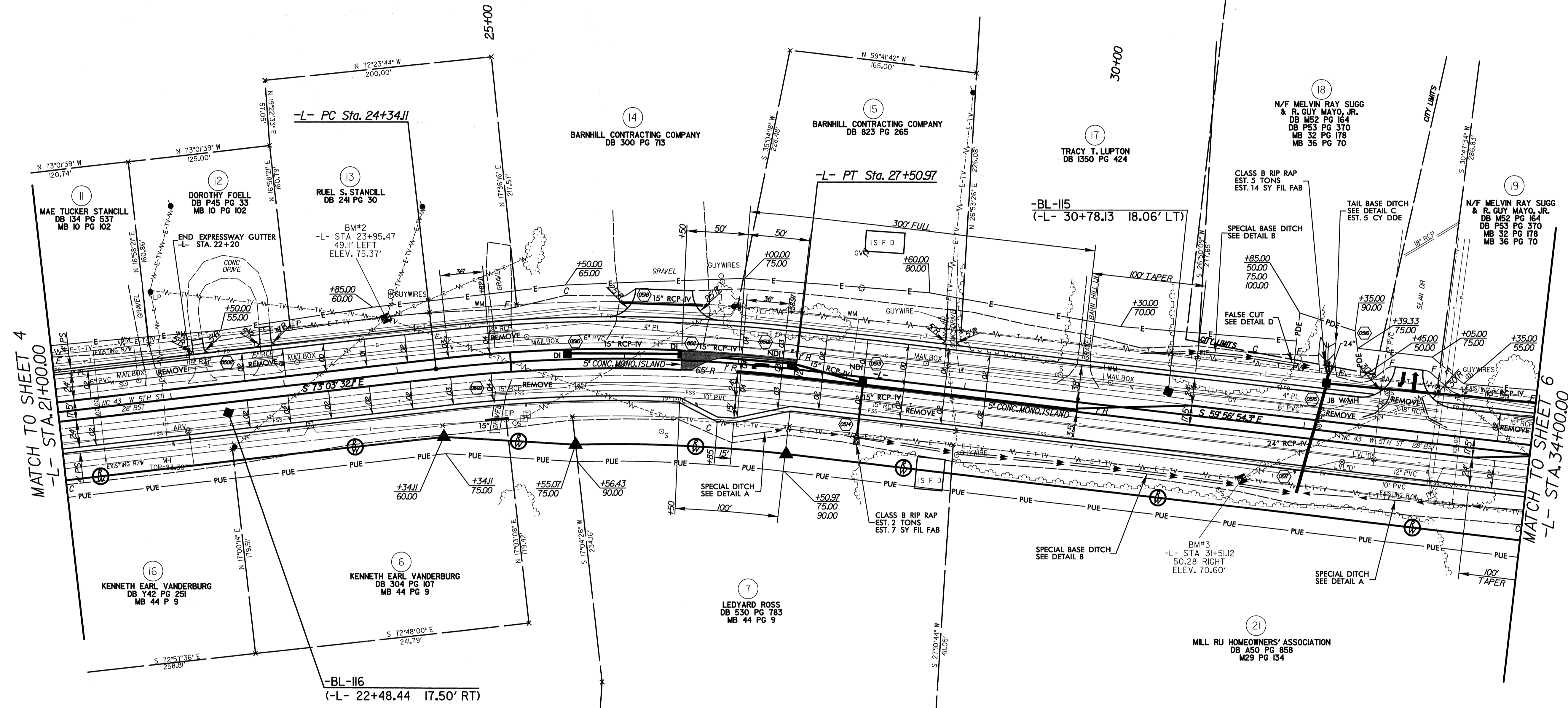

MATCH TO SHEET 4
 -L- STA. 21+00.00

MATCH TO SHEET 6
 -L- STA. 34+00.00

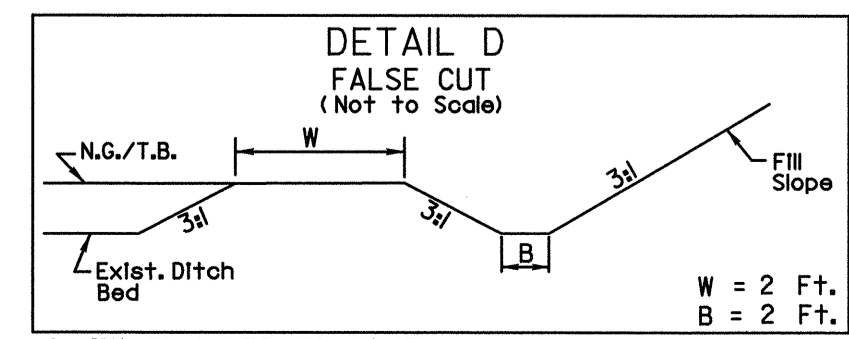
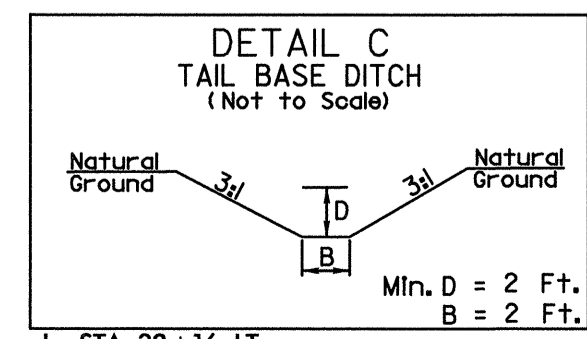
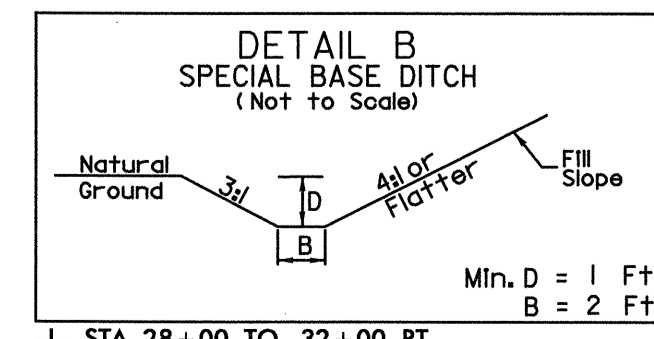
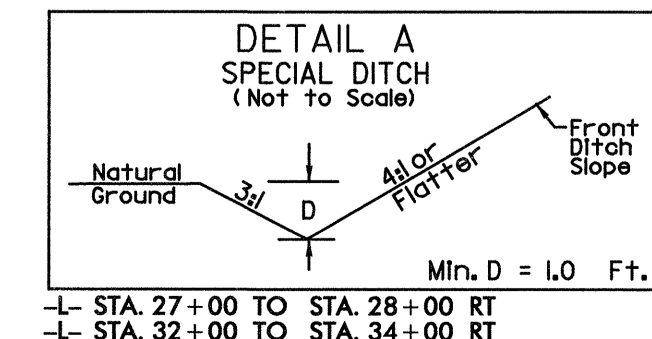

REVISIONS

5/27/2010
 P:\5018A\U5018A_rdy_psh5.dgn

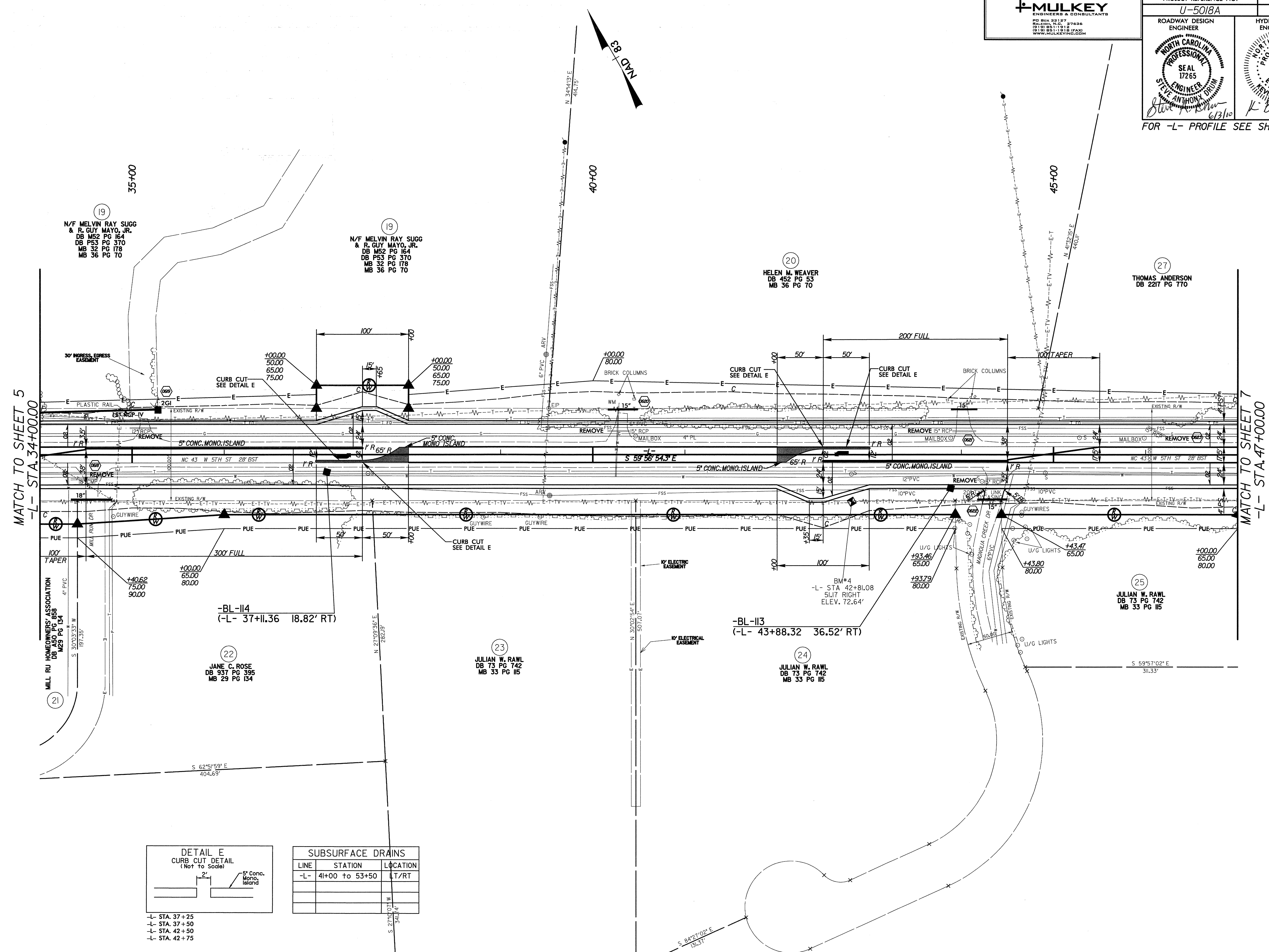

MATCH TO SHEET 5
-L- STA. 34+00.00

MATCH TO SHEET 7
-L- STA. 47+00.00

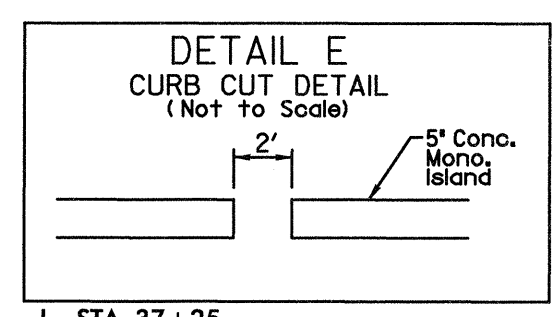

- L- STA. 37+25
- L- STA. 37+50
- L- STA. 42+50
- L- STA. 42+75

SUBSURFACE DRAINS

LINE	STATION	LOCATION
-L-	41+00 to 53+50	L/T/RT

REVISIONS

5/28/99

5/27/2010
P:\Projects\U5018A\U5018A_rdy_psh6.dgn

5/26/99

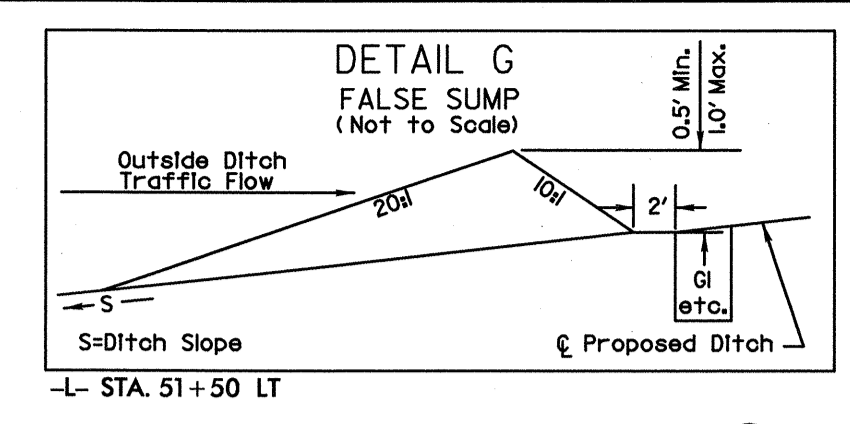
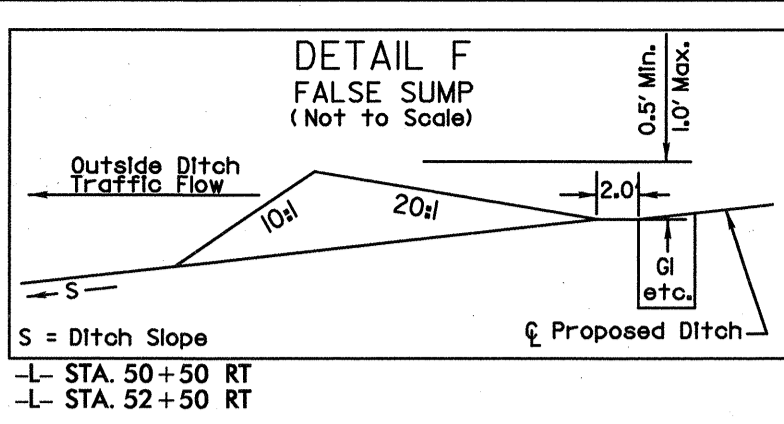
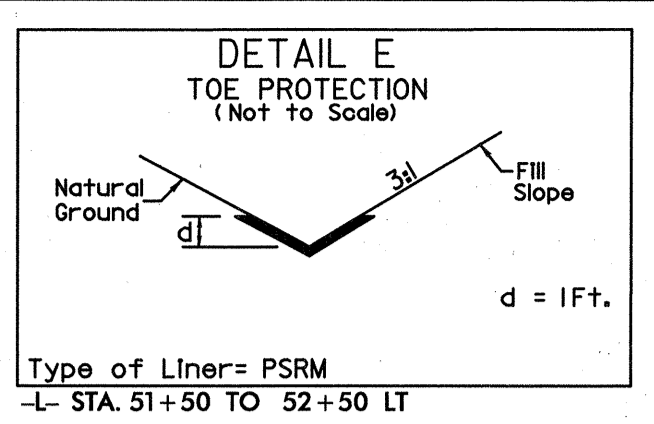
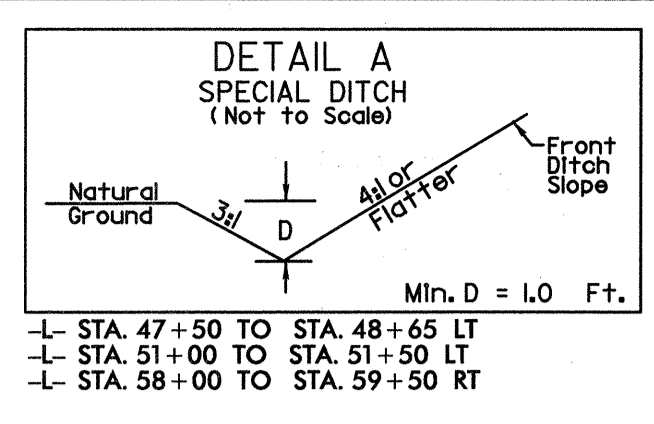

PI Sta 52+50.83
 $\Delta = 17' 01'' 22.4'' (RT)$
 $D = 6' 01'' 52.1''$
 $L = 282.25'$
 $T = 142.17'$
 $R = 950.00'$
 $SE = 04$
 $RO = 144'$

PI Sta 61+27.90
 $\Delta = 5' 09'' 00.9'' (RT)$
 $D = 1' 09'' 35.4''$
 $L = 444.05'$
 $T = 222.17'$
 $R = 4940.00'$
 $SE = 02$
 $RO = 72'$



PROJECT REFERENCE NO. U-5018A
ROADWAY DESIGN ENGINEER
HYDRAULICS ENGINEER

SEAL 17265
STEVE ANTHONY
6/3/10

SEAL 31977
NORTH CAROLINA PROFESSIONAL ENGINEER
12-10-06-3-10

FOR -L- PROFILE SEE SHEET 10
FOR STRUCTURES SEE SHEET S-1 thru S-52

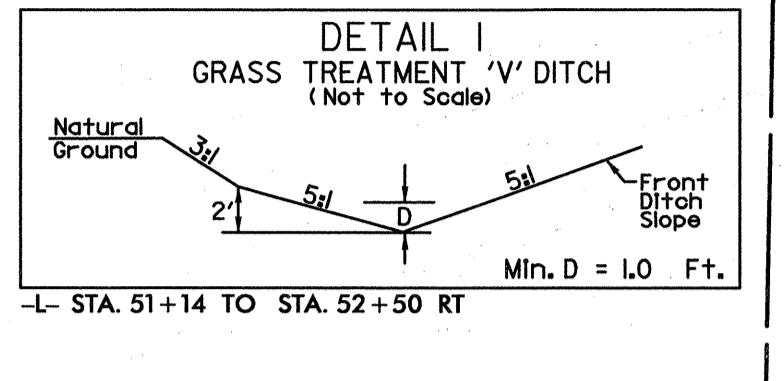
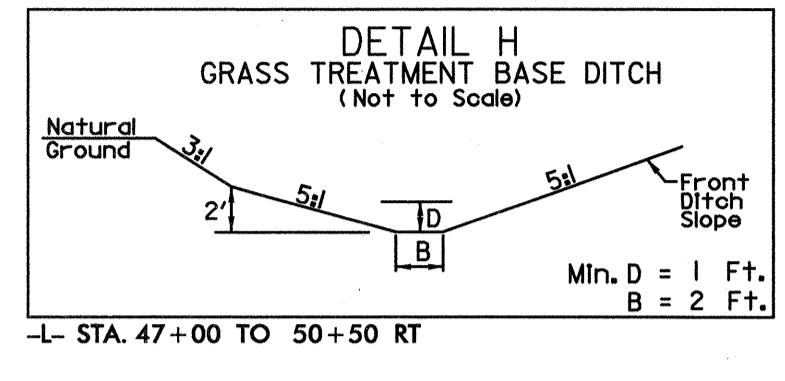

SUBSURFACE DRAINS

LINE	STATION	LOCATION
-L-	41+00 TO 53+50	LT/RT

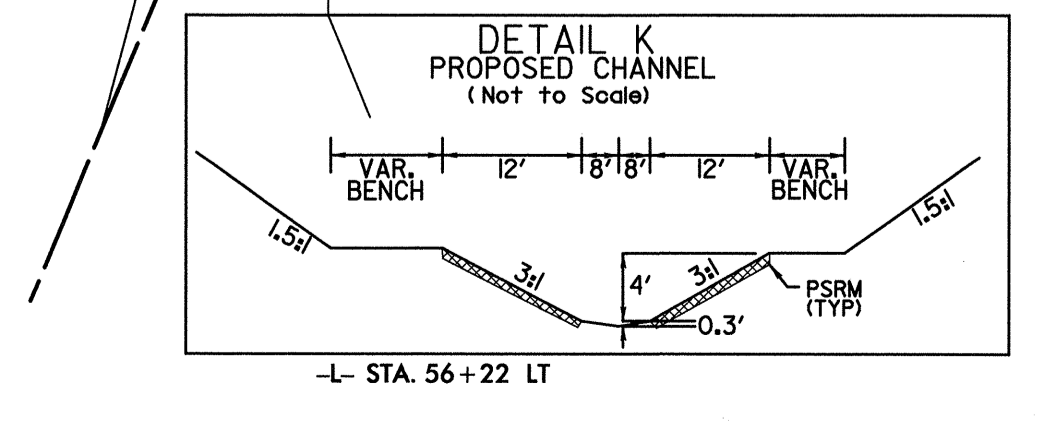
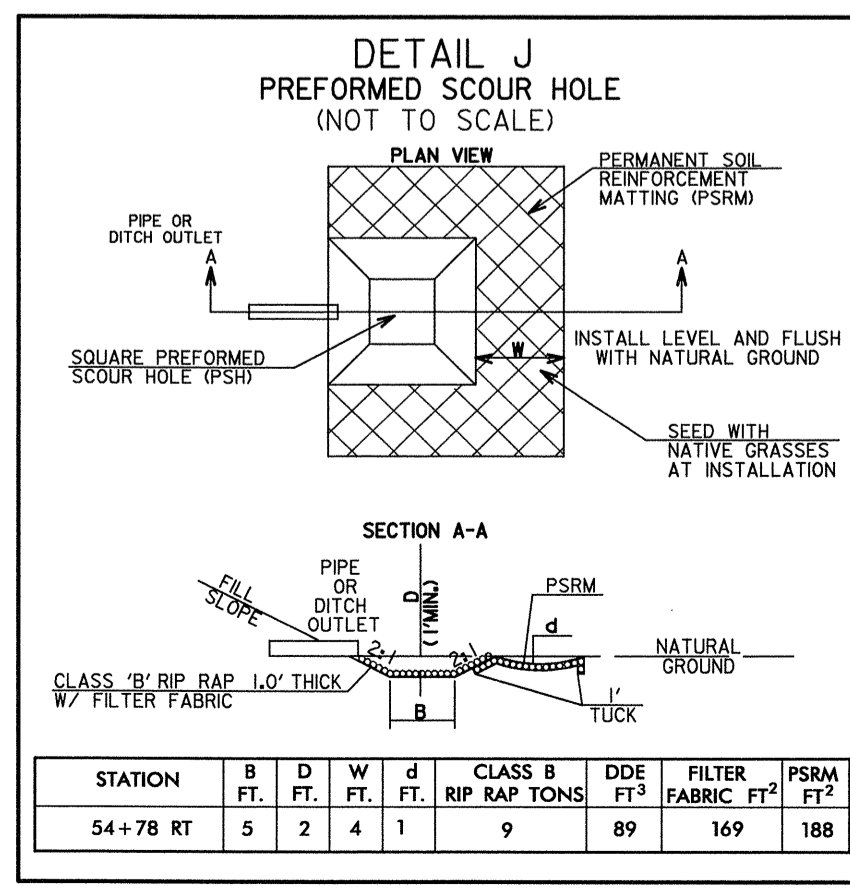
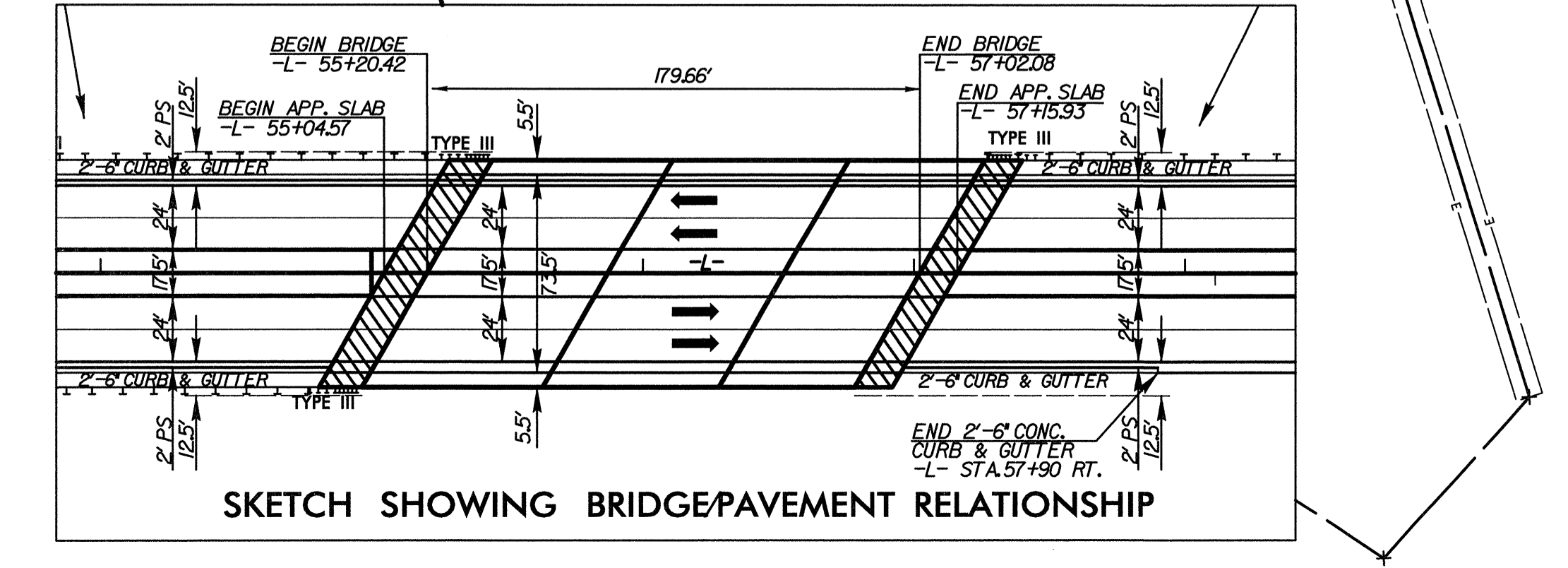
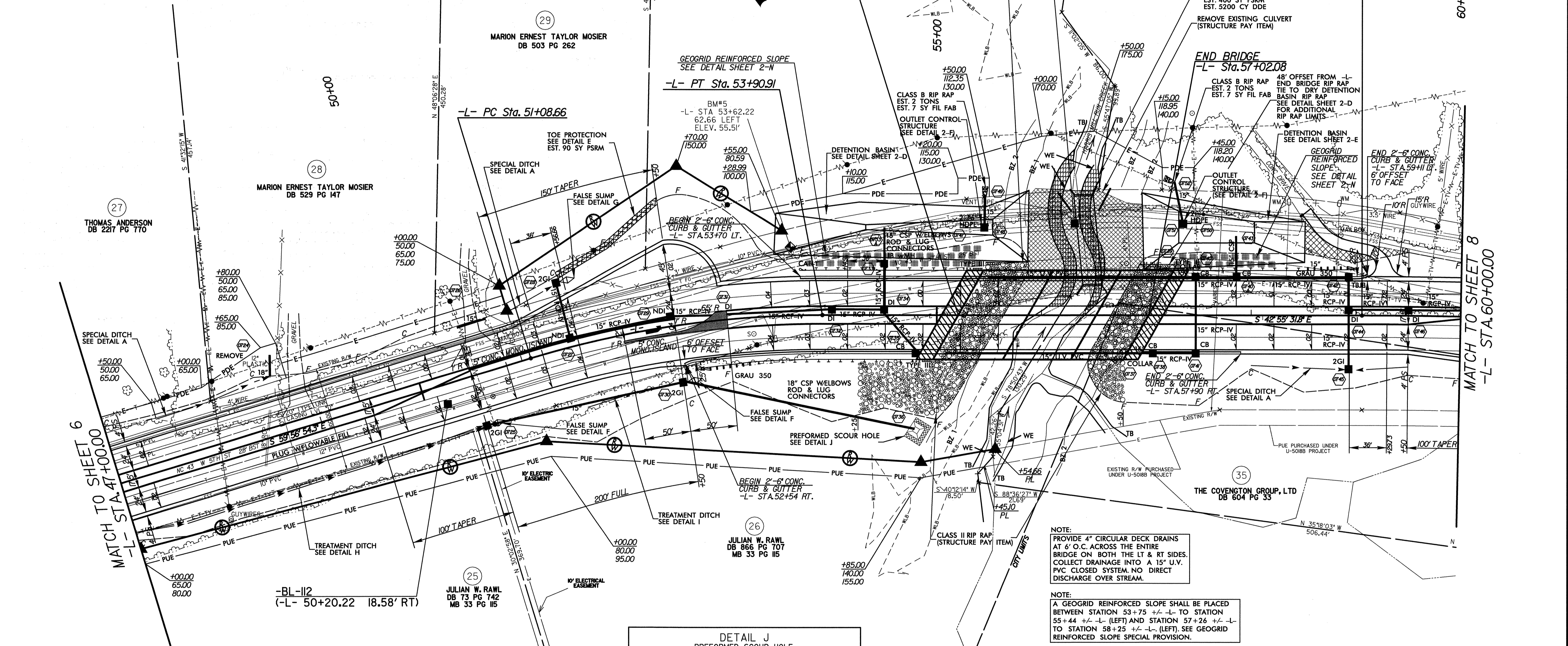

CULVERT EXCAVATION
 GEOGRID REINFORCED SLOPE

6/13/2010
R:\R06043\p\p\U5018A\U5018A_T-dy.dsn7.dgn
5:08:43 PM

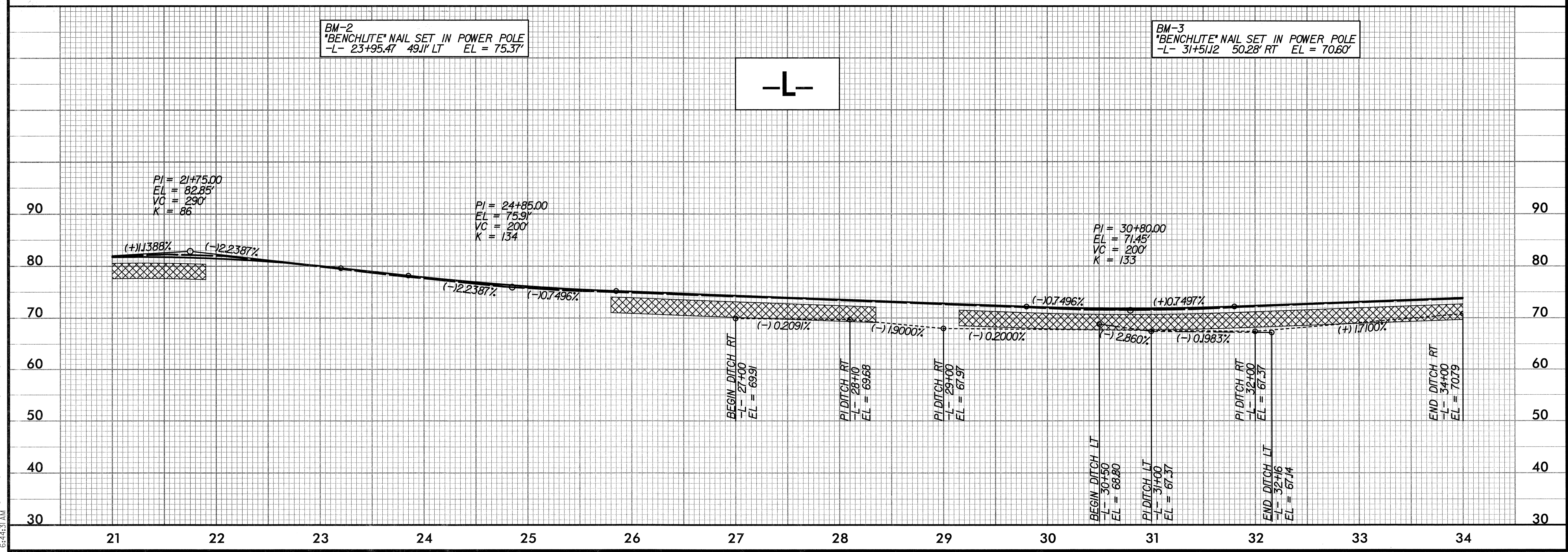
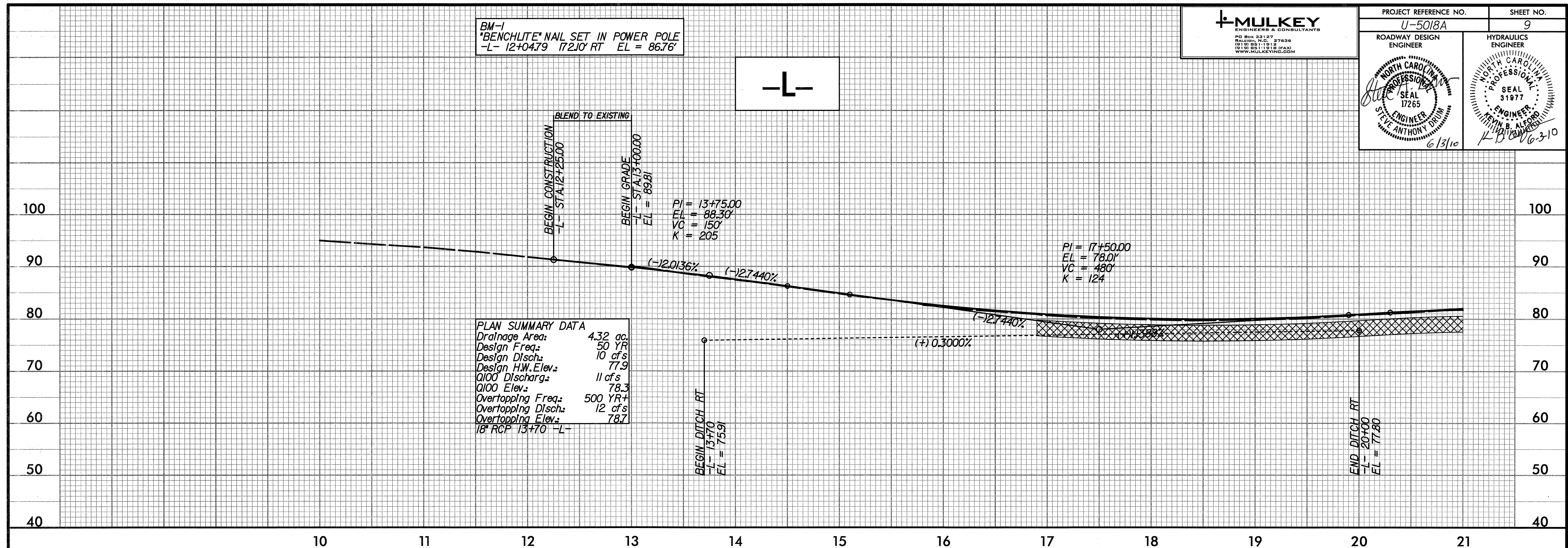

BM-4
 "BENCHLITE" NAIL SET IN POWER POLE
 -L- 42+81.08 517' RT EL = 72.64'

MULKEY
 ENGINEERS & CONSULTANTS
 P.O. BOX 33127
 RALEIGH, N.C. 27636
 (919) 881-1912 FAX
 WWW.MULKEYINC.COM

PROJECT REFERENCE NO. U-5018A		SHEET NO. 10	
ROADWAY DESIGN ENGINEER		HYDRAULICS ENGINEER	

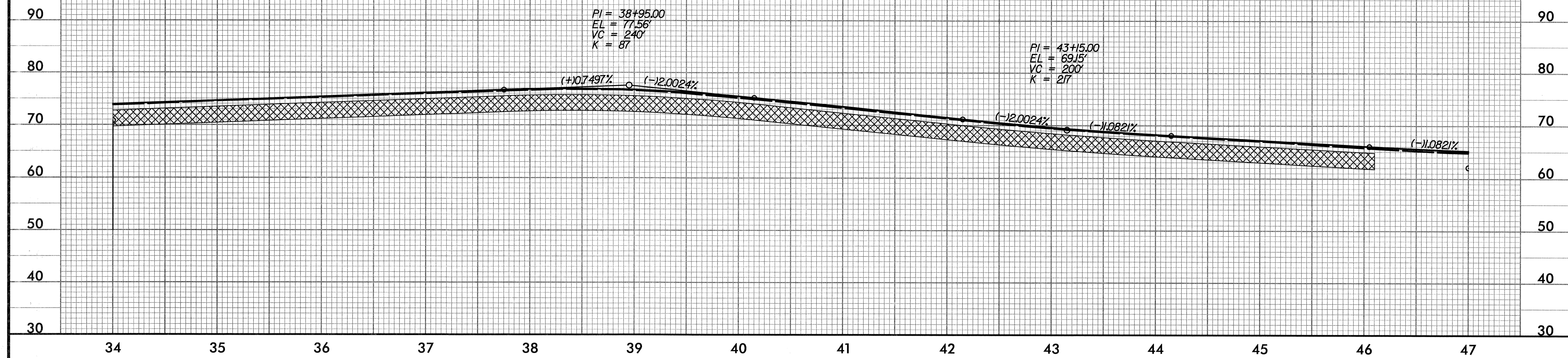

BM-5
 "BENCHLITE" NAIL SET IN 15" OAK
 -L- 53+62.22 64.66' LT EL = 55.51'

BRIDGE HYDRAULIC DATA	
Design Discharge =	750 CFS
Design Frequency =	50 YR
Design HW Elevation =	28.5
Base Discharge =	955 CFS
Base Frequency =	100 YR
Base HW Elevation =	29.1
Overtopping Discharge =	1500 CFS
Overtopping Frequency =	500 YR ++
Overtopping Elevation =	51.95
Date of Survey =	7/13/2007
W.S. Elevation at Date of Survey =	24.5

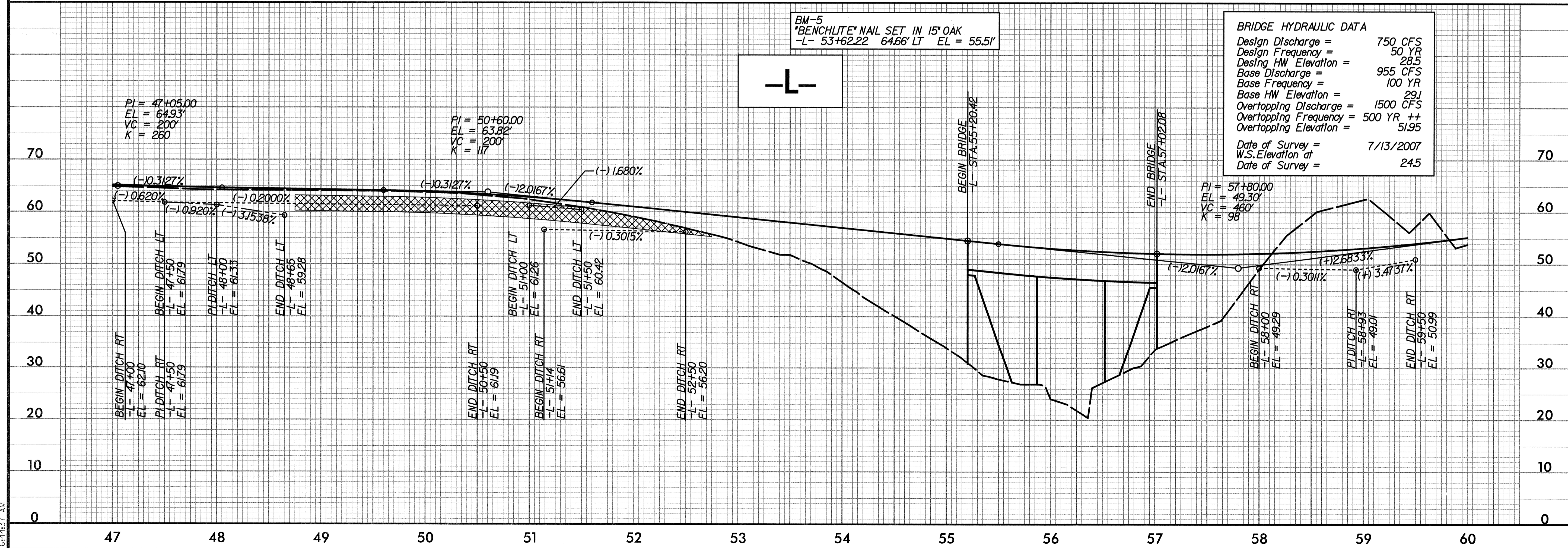

5/5/2010
 R:\Projects\U5018A\U5018A_rdy_dfl.dgn
 6:44:31 AM

ROADWAY DESIGN ENGINEER	HYDRAULICS ENGINEER
<i>Steve Anthony</i> 6/3/10	<i>Keith B. Alford</i> 6-3-10

BM-6
"BENCHLITE" NAIL SET IN POWER POLE
L- 64+78.59 23.62' LT EL = 56.65'

-L-

END GRADE
L- STA 62+50.00
L- EL = 58.92
PI = 62+60.00
EL = 62.18
VC = 500'
K = 85

