

8CR.10191.14  
42934

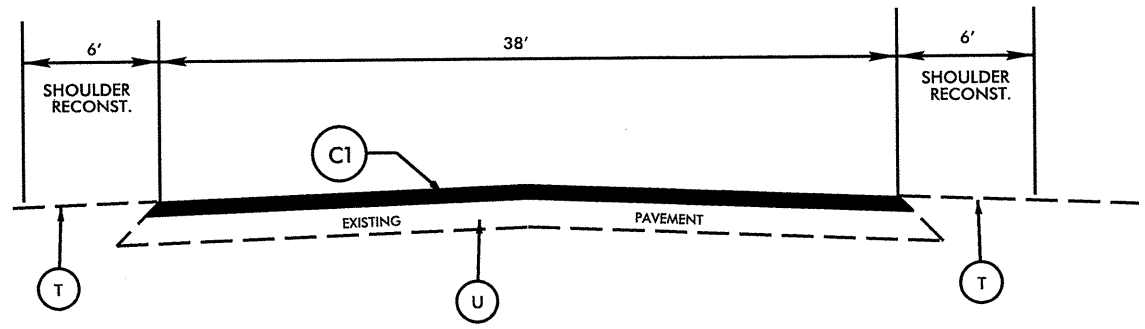

DIVISION DESIGN / CONSTRUCT ENGINEER



**TYPICAL SECTION NO.1**

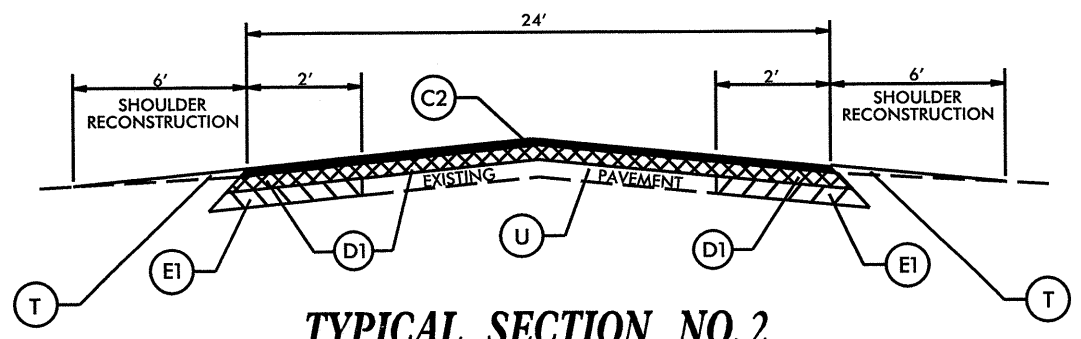

**TYPICAL SECTION NO.2**

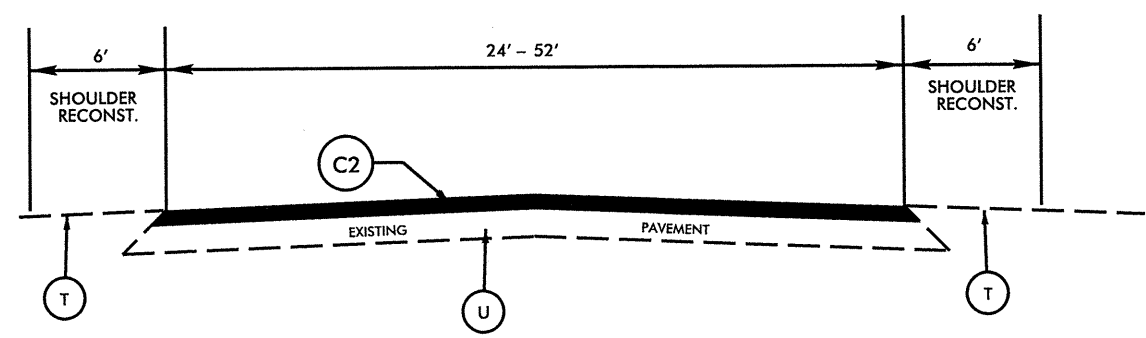

**TYPICAL SECTION NO.3**

NOTE: ALL RAMPS ON MAPS 1 AND 2 ARE TO BE RESURFACED FROM US 1 TO THE -Y- LINES USING THE SAME SURFACE MATERIAL AS US 1.

PAVEMENT SCHEDULE	
C1	PROP. APPROX. 1.5" ASPHALT CONCRETE SURFACE COURSE, TYPE S9.5C, AT AN AVERAGE RATE OF 168 LBS. PER SQ. YD.
C2	PROP. APPROX. 3.0" ASPHALT CONCRETE SURFACE COURSE, TYPE S9.5B, AT AN AVERAGE RATE OF 336 LBS. PER SQ. YD. IN EACH OF TWO LAYERS.
D1	PROP. APPROX. 3" ASPHALT CONCRETE INTERMEDIATE COURSE, TYPE I19.0B, AT AN AVERAGE RATE OF 342 LBS. PER SQ. YD.
E1	PROP. APPROX. 5" ASPHALT CONCRETE BASE COURSE, TYPE B25.0B AT AN AVERAGE RATE OF 570 LBS. PER SQ. YD.
U	EXISTING PAVEMENT.

040397

PROJECT NO.	SHEET NO.	TOTAL NO.
8CR.10191.14, 42934	4	

## SUMMARY OF QUANTITIES

PROJECT NO	COUNTY	MAP NO	ROUTE	DESCRIPTION	TYP NO	FINAL SURFACE TESTING REQUIRED	LENGTH MI	WIDTH FT	BORROW CY	INCIDENTAL STONE BASE TONS	SHOULDER RECONSTRUCTION SMI	INCIDENTAL MILLING SY	MILLED RUMBLE STRIPS LF	BASE COURSE, B25.0B TONS	INTERMEDIATE COURSE, I19.0B TONS	SURFACE COURSE, S9.5B TONS
8CR.10191.14	Chatham	1	US 1 NB	FROM LEE CO TO WAKE CO	1	NO	6.6	38	265		15.67	2115	69700			
<b>TOTAL FOR MAP NO. 1</b>							6.6		265		15.67	2115	69700			
		2	US 1 SB	FROM WAKE CO TO LEE CO	1	NO	6.6	38	265		16.23	2115	69700			
<b>TOTAL FOR MAP NO. 2</b>							6.6		265		16.23	2115	69700			
<b>TOTAL FOR PROJ NO. 8CR.10191.14</b>							13.2		530		31.9	4230	139400			
42934	Chatham	3	SR 1528	FROM PAVMT JOINT 0.29 MI EAST OF SR 1526 TO US 15-501	2	NO	0.87	24	75	87	1.8	270		830	2415	2375
<b>TOTAL FOR MAP NO. 3</b>							0.87		75	87	1.8	270	0	830	2415	2375
		4	SR 1528	FROM SR 1528 TO PAVMT JOINT 0.29 MI EAST OF SR 1526	3	NO	0.29	24-52	25	29	0.58	135		0	0	1300
<b>TOTAL FOR MAP NO. 4</b>							0.29		25	29	0.58	135	0	0	0	1300
		5	SR 1526	FROM PAVMT JOINT 0.39 MI WEST OF SR 1528 TO SR 1528	3	NO	0.39	24-52	30	39	0.78	135		0	0	1400
<b>TOTAL FOR MAP NO. 5</b>							0.39		30	39	0.78	135	0	0	0	1400
<b>TOTAL FOR PROJ NO. 42934</b>							1.55		130	155	3.16	540	0	830	2415	5075
<b>GRAND TOTAL</b>							14.75		660	155	35.06	4770	139400	830	2415	5075

PROJECT NO	COUNTY	MAP NO	ROUTE	DESCRIPTION	TYP NO	SURFACE COURSE, S9.5C TONS	PG 64-22 PLANT MIX TONS	PG 70-22 PLANT MIX TONS	PATCHING EXISTING PAVEMENT TONS	6" DRIVEWAYS SY	ADJ. OF METER OR VALVE BOX EA	TEMPORARY SILT FENCE LF	WATTLE LF	SEED & MULCHING AC	SEED FOR REPAIR SEEDING LB	FERTILIZER FOR REPAIR SEEDING TON
8CR.10191.14	Chatham	1	US 1 NB	FROM LEE CO TO WAKE CO	1	14,500		870	250			500	200	11.36	500	2
<b>TOTAL FOR MAP NO. 1</b>						14,500		870	250			500	200	11.36	500	2
		2	US 1 SB	FROM WAKE CO TO LEE CO	1	14,745		885	250			500	200	11.77	500	2
<b>TOTAL FOR MAP NO. 2</b>						14,745		885	250			500	200	11.77	500	2
<b>TOTAL FOR PROJ NO. 8CR.10191.14</b>						29,245		1,755	500			1,000	400	23.13	1,000	4
42934	Chatham	3	SR 1528	FROM PAVMT JOINT 0.29 MI EAST OF SR 1526 TO US 15-501	2		292		1,050	200	5	50	25	1.26	50	0.25
<b>TOTAL FOR MAP NO. 3</b>							292		1,050	200	5	50	25	1.26	50	0.25
		4	SR 1528	FROM SR 1528 TO PAVMT JOINT 0.29 MI EAST OF SR 1526	3		78				5	50	25	0.42	50	0.25
<b>TOTAL FOR MAP NO. 4</b>							78				5	50	25	0.42	50	0.25
		5	SR 1526	FROM PAVMT JOINT 0.39 MI WEST OF SR 1528 TO SR 1528	3		84				5	50	25	0.57	50	0.25
<b>TOTAL FOR MAP NO. 5</b>							84				5	50	25	0.57	50	0.25
<b>TOTAL FOR PROJ NO. 42934</b>							454		1,050	200	15	150	75	2.25	150	0.75
<b>GRAND TOTAL</b>						29,245	454	1,755	1,550	200	15	1,150	475	25.38	1,150	4.75

PROJECT NO.	SHEET NO.	TOTAL NO.
8CR.10191.14, 42934	5	

## THERMOPLASTIC AND PAINT QUANTITIES

PROJECT NO	COUNTY	MAP NO	ROUTE	DESCRIPTION	4589000000-N	4725000000-E			4775000000-E	4810000000-E		4815000000-E		4847000000-E		4847100000-E		4847120000-E	4900000000-N		4905000000-N	
					TRAFFIC CONTROL	THERMO STR ARROW 90 M	THERMO LT ARROW 90 M	THERMO RT ARROW 90 M	COLD APPLIED PLASTIC PAVEMENT MARKING LINES, TYPE III (6")	4" WHITE PAINT	4" YELLOW PAINT	6" WHITE PAINT	6" YELLOW PAINT	4" YELLOW POLYUREA STD. BEADS	4" WHITE POLYUREA STD. BEADS	6" WHITE POLYUREA H.R.E.	6" YELLOW POLYUREA H.R.E.	8" YELLOW POLYUREA H.R.E.	12" WHITE POLYUREA H.R.E.	YELLOW & YELLOW MARKERS	CYAN & RED MARKERS	SNOW PLOWABLE MARKERS C & R MARKERS
					LS	EA	EA	EA	LF	LF	LF	LF	LF	LF	LF	LF	LF	EA	EA	EA		
8CR.10191.14	Chatham	1	US 1 NB	FROM LEE CO TO WAKE CO	1	9			890			42,500	42,500			51,215	42,500		1,500		640	
TOTAL FOR MAP NO. 1					1	9			890			42,500	42,500			51,215	42,500		1,500		640	
		2	US 1 SB	FROM WAKE CO TO LEE CO	*	9			890			44,000	44,000			52,715	44,000		1,500		640	
TOTAL FOR MAP NO. 2						9			890			44,000	44,000			52,715	44,000		1,500		640	
TOTAL FOR PROJ NO. 8CR.10191.14					1	18			1,780			86,500	86,500			103,930	86,500		3,000		1,280	
							18					173,000				190,430						
42934	Chatham	3	SR 1528	FROM PAVMT JOINT 0.29 MI EAST OF SR 1526 TO US 15-501							18,000	18,000			9,365	9,365				57		
TOTAL FOR MAP NO. 3											18,000	18,000			9,365	9,365				57		
		4	SR 1528	FROM SR 1528 TO PAVMT JOINT 0.29 MI EAST OF SR 1526		5	6	4			3,000	1,000			1,000	3,410			250	29	15	
TOTAL FOR MAP NO. 4						5	6	4			3,000	1,000			1,000	3,410			250	29	15	
		5	SR 1526	FROM PAVMT JOINT 0.39 MI WEST OF SR 1528 TO SR 1528		5	6	4			4,000	6,500			6,770	4,200			250	56	15	
TOTAL FOR MAP NO. 5						5	6	4			4,000	6,500			6,770	4,200			250	56	15	
TOTAL FOR PROJ NO. 42934						10	12	8			25,000	25,500			17,135	16,975			500	142	30	
							30				50,500				34,110				172			
GRAND TOTAL					1	28	12	8	1,780		25,000	25,500	86,500	86,500	17,135	16,975	103,930	86,500	500	3,000	142	30
							48				50,500				34,110			190,430		172		1,280

42934  
8CR.101091.14

PROJECT REFERENCE NO. X-XXXX	SHEET NO. EC-
RW SHEET NO.	
ROADWAY DESIGN ENGINEER	HYDRAULICS ENGINEER

# WATTLE DETAIL

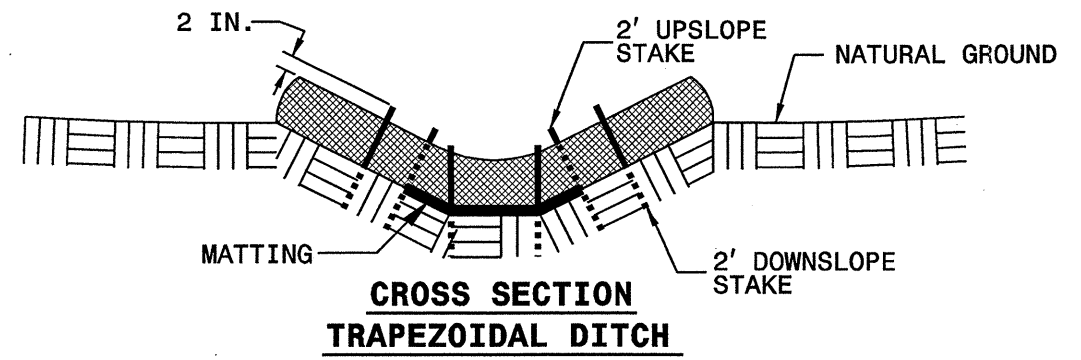
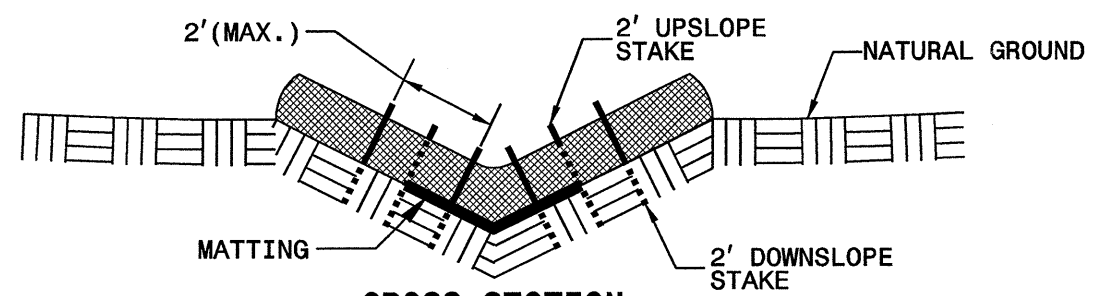
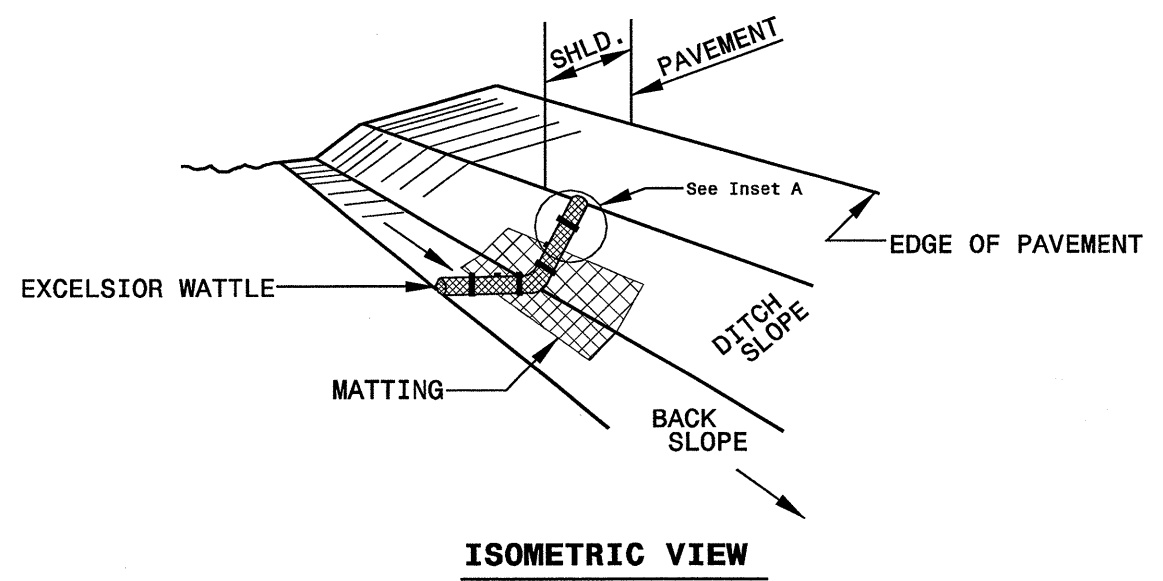

- NOTES:**
- USE MINIMUM 12 IN. DIAMETER EXCELSIOR WATTLE.
  - USE 2 FT. WOODEN STAKES WITH A 2 IN. BY 2 IN. NOMINAL CROSS SECTION.
  - ONLY INSTALL WATTLE(S) TO A HEIGHT IN DITCH SO FLOW WILL NOT WASH AROUND WATTLE AND SCOUR DITCH SLOPES AND AS DIRECTED.
  - INSTALL A MINIMUM OF 2 UPSLOPE STAKES AND 4 DOWNSLOPE STAKES AT AN ANGLE TO WEDGE WATTLE TO BOTTOM OF DITCH.
  - PROVIDE STAPLES MADE OF 0.125 IN. DIAMETER STEEL WIRE FORMED INTO A U SHAPE NOT LESS THAN 12" IN LENGTH.
  - INSTALL STAPLES APPROXIMATELY EVERY 1 LINEAR FOOT ON BOTH SIDES OF WATTLE AND AT EACH END TO SECURE IT TO THE SOIL.
  - INSTALL MATTING IN ACCORDANCE WITH SECTION 1631 OF THE STANDARD SPECIFICATIONS.

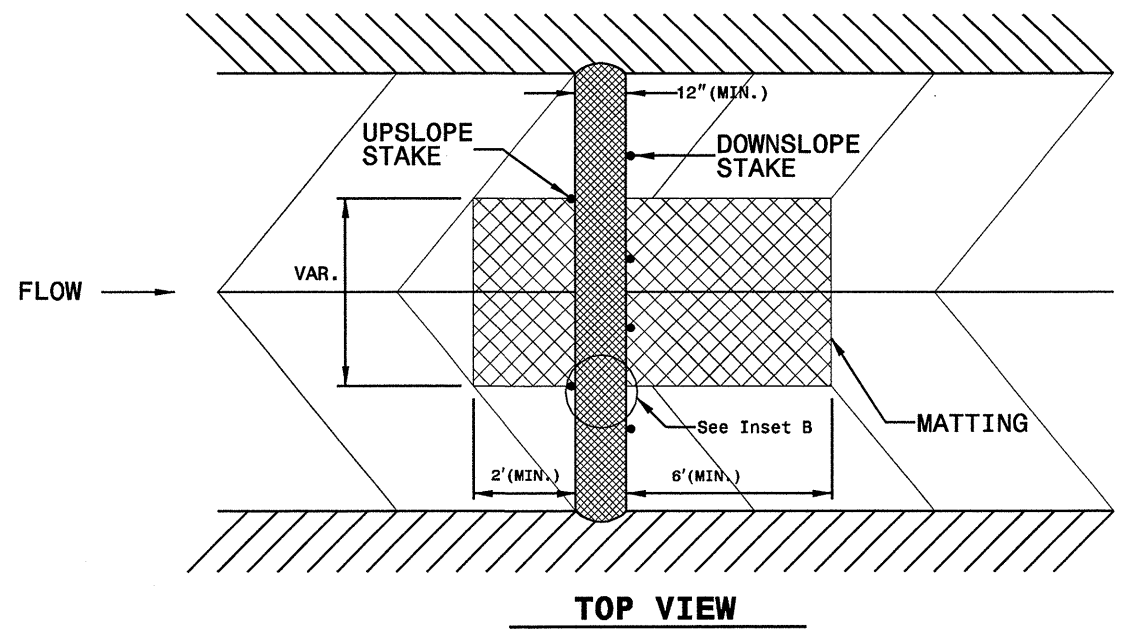
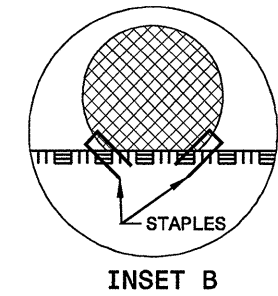
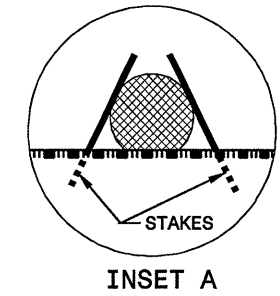



**ADVANCE WORK ZONE WARNING SIGNING FOR FREEWAYS (4 LANES OR GREATER)**

**DETAIL A**

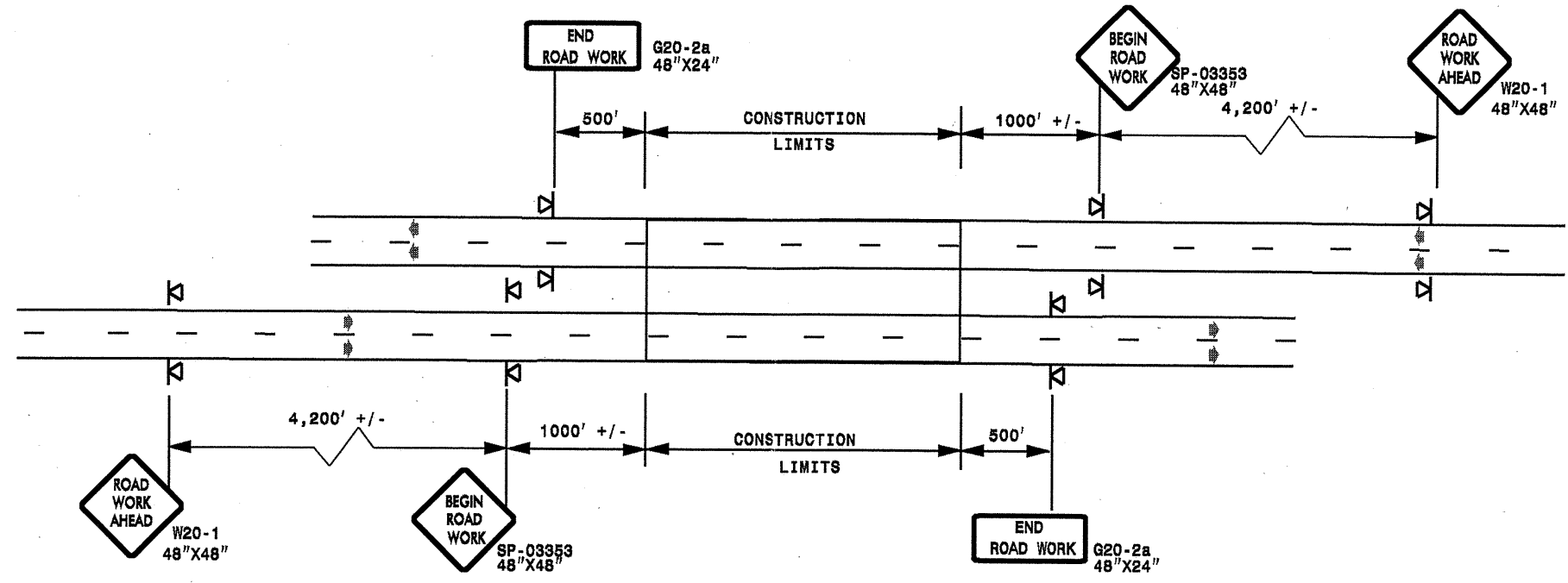

STATE OF NORTH CAROLINA  
DEPT. OF TRANSPORTATION  
DIVISION OF HIGHWAYS  
RALEIGH, N.C.

**ROADWAYS INTERSECTING ALONG FREEWAY WORK ZONE (Y-LINES)**

**DETAIL B**

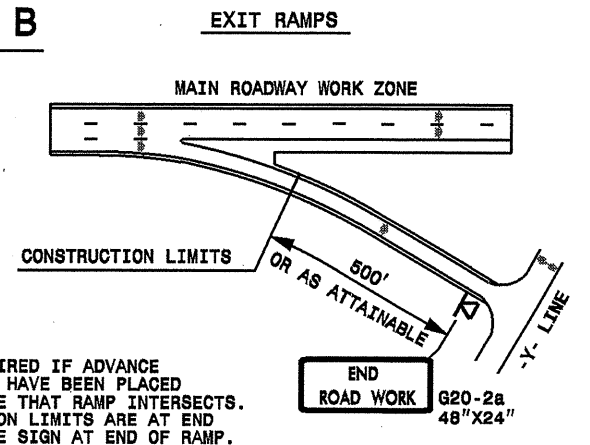

NOTE:  
SIGN NOT REQUIRED IF ADVANCE WARNING SIGNS HAVE BEEN PLACED ALONG -Y- LINE THAT RAMP INTERSECTS. IF CONSTRUCTION LIMITS ARE AT END OF RAMP, PLACE SIGN AT END OF RAMP.

**DETAIL C**

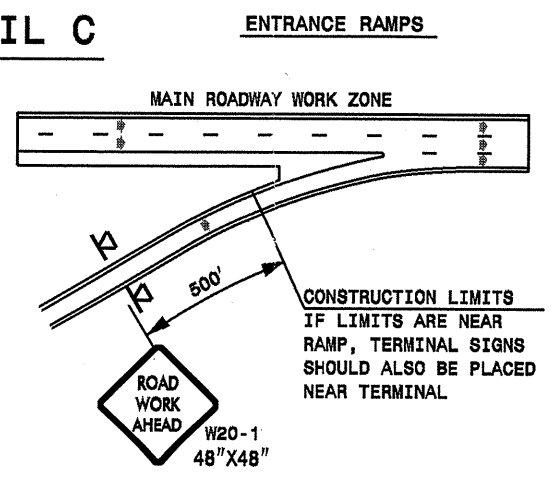

CONSTRUCTION LIMITS IF LIMITS ARE NEAR RAMP, TERMINAL SIGNS SHOULD ALSO BE PLACED NEAR TERMINAL

**DETAIL D**

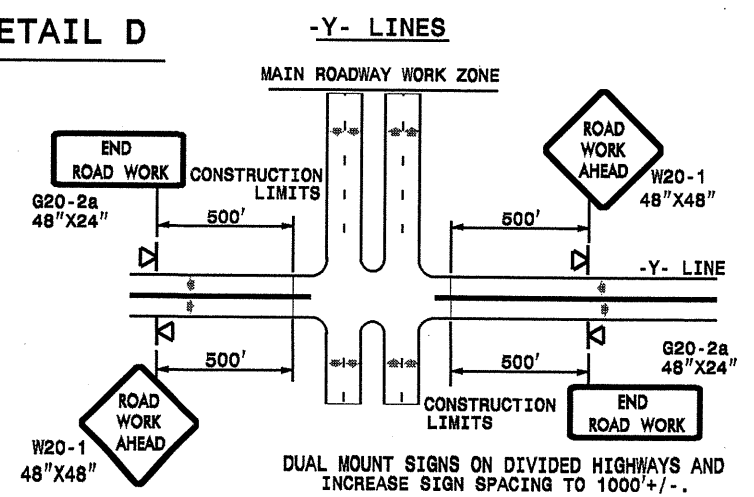

DUAL MOUNT SIGNS ON DIVIDED HIGHWAYS AND INCREASE SIGN SPACING TO 1000'+/-.

**DETAIL DRAWING  
FOR FREEWAYS  
WORK ZONE WARNING SIGNS  
(SHORT-DURATION LANE CLOSURES)**

**GENERAL NOTES**

- USE FLUORESCENT ORANGE SHEETING (TYPE VII OR HIGHER) ON ALL ADVANCE WORK ZONE SIGNS.
- DO NOT INSTALL ADVANCE WARNING SIGNS MORE THAN 3 DAYS PRIOR TO BEGINNING OF WORK.
- ALL SIGN SPACING DIMENSIONS ARE APPROXIMATE, FIELD ADJUST AS NECESSARY OR AS DIRECTED.
- USE PORTABLE WORK ZONE SIGNS ONLY WITH PORTABLE WORK ZONE SIGN STANDS SPECIFICALLY DESIGNED FOR ONE ANOTHER. PORTABLE WORK ZONE SIGNS MAY BE ROLL UP OR APPROVED COMPOSITE.
- PROVIDE PORTABLE WORK ZONE SIGN STANDS, PORTABLE SIGNS AND SIGN SHEETING WHICH ARE LISTED ON THE NORTH CAROLINA DEPARTMENT OF TRANSPORTATION'S APPROVED PRODUCT LIST OR ACCEPTED AS TRAFFIC QUALIFIED BY THE TRAFFIC CONTROL UNIT.
- \*\* TWO-WAY UNDIVIDED ADVANCE WARNING SIGN CONFIGURATION MAY BE USED ON MULTI-LANE FACILITIES WHERE CONDITIONS LIMIT THE USE OF DUAL MOUNTED SIGNS AS DETERMINED BY THE ENGINEER.

**LEGEND**

◀ PORTABLE SIGN

➔ DIRECTION OF TRAFFIC FLOW

SHEET 1 OF 1

APPROVED:	DATE:	DETAIL DRAWING FOR FREEWAYS WORK ZONE WARNING SIGNS	
SEAL			
SCALE:	NONE	REVISIONS	
DATE:		7-98	10/01
DWG. BY:		10-98	03/04
DESIGN BY:		01/01	11/04
REVIEWED BY:			

29-JUN-2010 18:43  
S:\Signing\resur\_facing\_030509\Resur\_facing\2010\Div08\VC202608A-B-42934x2.Chotham\_USletom\VC202608A-B-42934x2\_freewaysproject.july2006.por\table.dgn  
pseymore AT WZTC237502