

STATE OF NORTH CAROLINA
DEPARTMENT OF TRANSPORTATION

TIP NO.	SHEET NO.
B-3693	PMP - 1
APPROVED: <i>[Signature]</i>	
DATE: 2/9/10	
SEAL	
	

PAVEMENT MARKING PLAN
ROBESON COUNTY

LOCATION: BRIDGE NO. 207 OVER HOLLY SWAMP AND BRIDGE
NOS. 210 AND 211 OVER RAFT SWAMP ON SR 1527

T.I.P.: B-3693

CONTRACT: C202549

ROADWAY STANDARD DRAWING

THE FOLLOWING ROADWAY STANDARDS AS APPEAR IN "ROADWAY STANDARD DRAWINGS" - PROJECT SERVICES UNIT - N.C. DEPARTMENT OF TRANSPORTATION - RALEIGH, N.C., DATED JULY 2006 ARE APPLICABLE TO THIS PROJECT AND BY REFERENCE HEREBY ARE CONSIDERED A PART OF THESE PLANS:

STD. NO.	TITLE
1205.01	PAVEMENT MARKINGS - LINE TYPES AND OFFSETS
1205.02	PAVEMENT MARKINGS - 2 LANE AND MULTILANE ROADWAYS
1205.12	PAVEMENT MARKINGS - BRIDGES
1250.01	PAVEMENT MARKER SPACING
1251.01	RAISED PAVEMENT MARKERS - TEMPORARY AND PERMANENT
1261.01	GUARDRAIL AND BARRIER DELINEATOR SPACING
1261.02	GUARDRAIL AND BARRIER DELINEATOR TYPES
1262.01	GUARDRAIL END DELINEATION

GENERAL NOTES

THE FOLLOWING GENERAL NOTES APPLY AT ALL TIMES FOR THE DURATION OF THE CONSTRUCTION PROJECT, EXCEPT WHEN OTHERWISE NOTED IN THE PLAN, OR DIRECTED BY THE ENGINEER.

A) INSTALL PAVEMENT MARKINGS AND PAVEMENT MARKERS ON THE FINAL SURFACE AS FOLLOWS:

ROAD NAME	MARKING	MARKER
SR 1527 (PINE LOG RD.)	THERMOPLASTIC	RAISED
BRIDGES	COLD-APPLIED PLASTIC (TYPE 2)	RAISED

- B) TIE PROPOSED PAVEMENT MARKING LINES TO EXISTING PAVEMENT MARKING LINES.
C) REMOVE/REPLACE ANY CONFLICTING/DAMAGED PAVEMENT MARKINGS AND MARKERS.
D) PASSING ZONES WILL BE DETERMINED IN THE FIELD AND MUST BE APPROVED BY THE ENGINEER.

INDEX

SHEET NO.	DESCRIPTION
PMP - 1	PAVEMENT MARKING PLAN COVER SHEET
PMP - 2	PAVEMENT MARKING SCHEDULE
PMP - 3 - 4	PAVEMENT MARKING DETAIL

PLAN PREPARED BY: N.C.D.O.T. SIGNING AND DELINEATION UNIT

A.I. Alqudwah, P.E. SIGNING & DELINEATION REGIONAL ENGINEER

D.M. Eaton SIGNING & DELINEATION PROJECT DESIGN ENGINEER/TECHNICIAN

TIP NO. B-3693	SHEET NO. PMP-2
APPROVED: <i>[Signature]</i>	
DATE: 2/10/10	
SEAL	
	

B-3693 FINAL PAVEMENT MARKING SCHEDULE

<u>SYMBOL</u>	<u>DESCRIPTION</u>	<u>PAY ITEM QUANTITY</u>	<u>TOTAL</u>
FINAL PAVEMENT MARKINGS			
COLD APPLIED PLASTIC (4") Type2 - Permanent High Performance			
CA	WHITE EDGELINE	642 LF	
CI	YELLOW DOUBLE CENTER	642 LF	
		TOTAL	1284 LF
THERMOPLASTIC(4", 120 MILS)			
TI	YELLOW DOUBLE CENTER	3558 LF	
		TOTAL	3558 LF
THERMOPLASTIC(4", 90 MILS)			
TA	WHITE EDGELINE	3558 LF	
		TOTAL	3558 LF
MARKERS			
PERMANENT RAISED PAVEMENT MARKERS			
MA	YELLOW & YELLOW	26 EA	
		TOTAL	26 EA

PAVEMENT MARKING SCHEDULE

08-FEB-2010 09:04
 P:\TIP\Project\B3693\Traffic\Signing\CADD\Signing Layout Plans\B-3693-Sgn-BPMP.dgn
 meaton AT TELC22656

TIP NO. B-3693	SHEET NO. PMP-3
APPROVED: <i>[Signature]</i>	
DATE: 2/10/10	
SEAL	



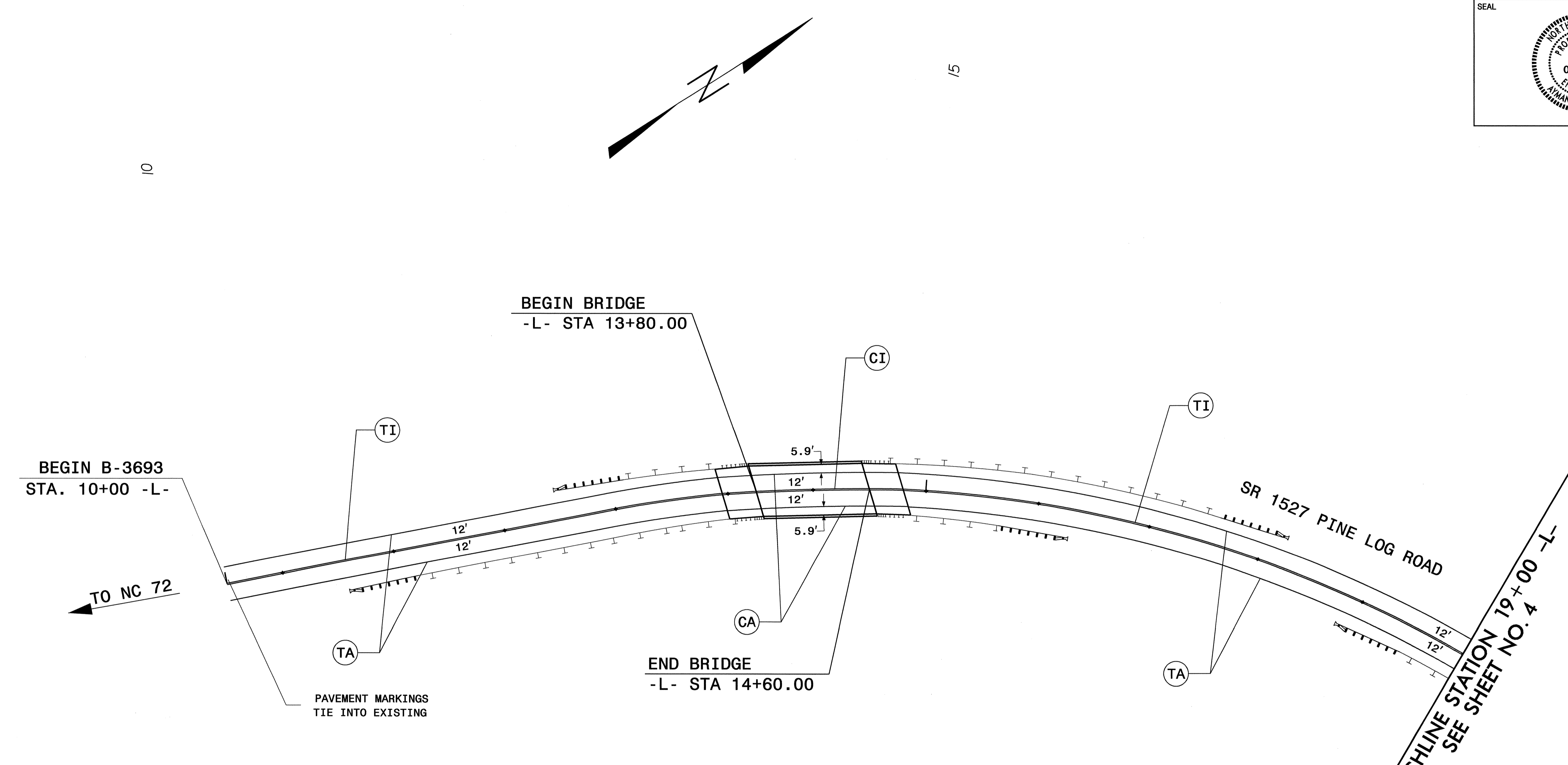

SYMBOL AND PAVEMENT MARKING LEGEND	
<u>THERMOPLASTIC</u>	
(TA)	WHITE EDGELINE (4")
(TI)	YELLOW DOUBLE CENTER (4")
<u>COLD APPLIED PLASTIC</u>	
(CA)	WHITE EDGELINE (4")
(CI)	YELLOW DOUBLE CENTER (4")

PAVEMENT MARKING DETAIL

08-FEB-2010 09:06
 P:\TIP\B-3693\Traffic\Signing\CADD\Signing Layout Plans\B-3693_Sgn_BFMP.dgn
 meaton

TIP NO. B-3693	SHEET NO. PMP-4
APPROVED: <i>[Signature]</i>	
DATE: 2/10/10	
SEAL	

MATCHLINE STATION 19+00 -L-
SEE SHEET NO. 3

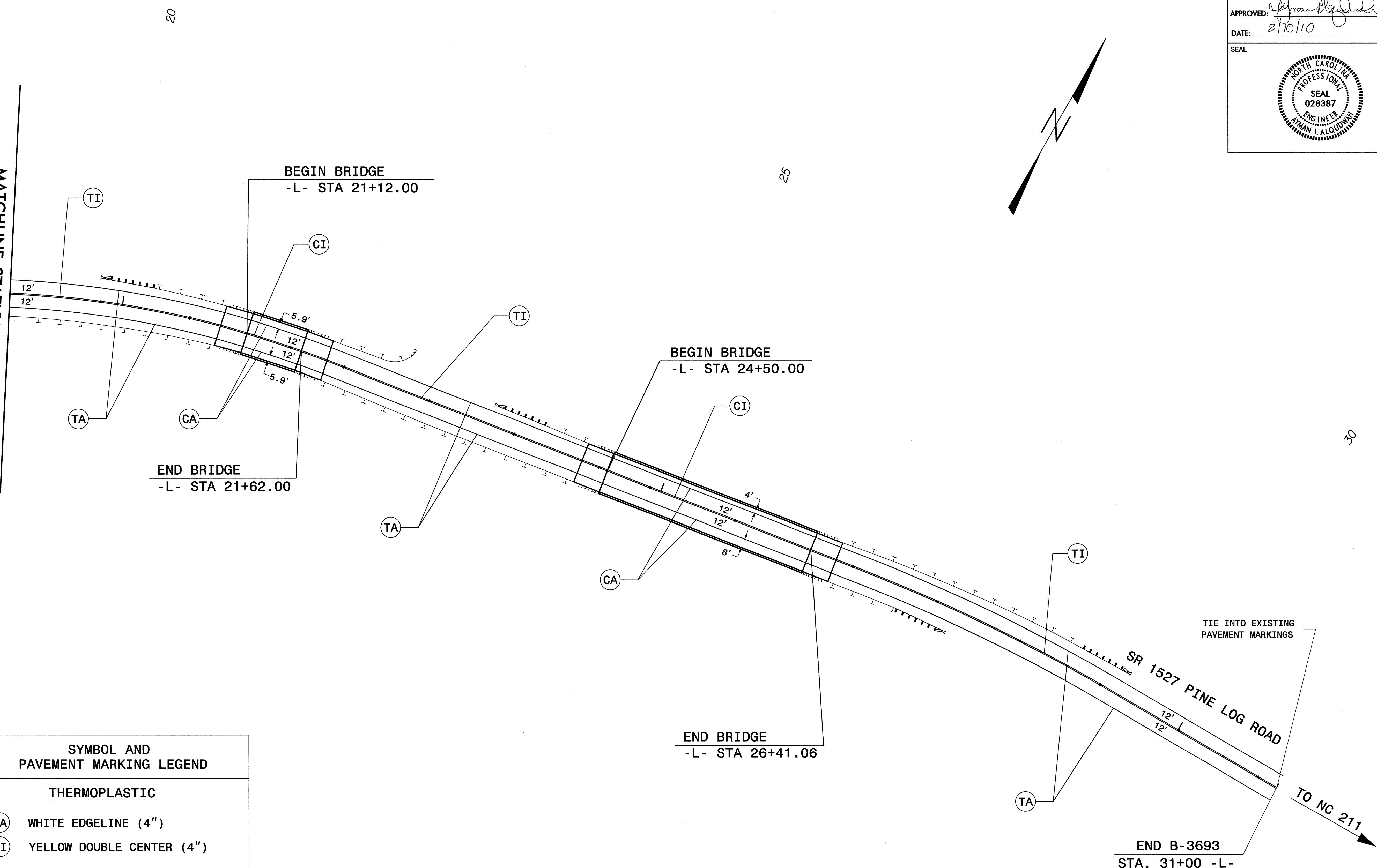

SYMBOL AND PAVEMENT MARKING LEGEND	
<u>THERMOPLASTIC</u>	
(TA)	WHITE EDGELINE (4")
(TI)	YELLOW DOUBLE CENTER (4")
<u>COLD APPLIED PLASTIC</u>	
(CA)	WHITE EDGELINE (4")
(CI)	YELLOW DOUBLE CENTER (4")

PAVEMENT MARKING DETAIL

08 FEB 2010 09:56 P:\TIP\B-3693\Traffic\Signing\CA00\Signing Layout Plans\B-3693_Sgn_BPMP.dgn