

## PAVEMENT MARKING SCHEDULE

<u>DESCRIPTION</u> PAVEMENT MARKINGS	<u>PAY ITEM</u> QUANTITY		<u>TOTAL</u> QUANTITY
<u>PAVEMENT MARKINGS</u>			
<u>THERMOPLASTIC (4", 120 MILS)</u>			
2' WHITE MINI SKIP LINE	1450 LF		
10' WHITE SKIP LINE	10450 LF		
WHITE SOLID LANE LINE	12850 LF		
		TOTAL	24750 LF
<u>THERMOPLASTIC (8", 120 MILS)</u>			
WHITE CROSS WALK LINE	330 LF		
		TOTAL	330 LF
<u>THERMOPLASTIC (8", 90 MILS)</u>			
WHITE DIAGONAL LINE	100 LF		
		TOTAL	100 LF
<u>THERMOPLASTIC (24", 120 MILS)</u>			
WHITE STOP BAR	1425 LF		
		TOTAL	1425 LF
<u>THERMOPLASTIC PAVING MARKING SYMBOLS (90 MILS)</u>			
LEFT TURN ARROW	70 EA		
RIGHT TURN ARROW	39 EA		
STRAIGHT ARROW	103 EA		
COMBINATION STRAIGHT/RIGHT ARROW	19 EA		
U-TURN ARROW	16 EA		
		TOTAL	247 EA
<u>THERMOPLASTIC PAVING MARKING CHARACTERS (120 MILS)</u>			
ALPHANUMERIC CHARACTER	36 EA		
		TOTAL	36 EA
<u>RAISED PAVEMENT MARKERS</u>			
CRYSTAL & RED	750 EA		
		TOTAL	750 EA

APPROVED: _____	DATE: 4/16/10	<b>PAVEMENT MARKING QUANTITIES</b>	
	SCALE:		
	DATE: 01/09		
	DWG. BY:		
	DESIGN BY: I.DERNEY		
REVIEWED BY:	REVISIONS		
	01/10		

BEGIN PROJECT STA. 1+00+/- -L-  
TIE PAVEMENT MARKINGS TO EXISTING

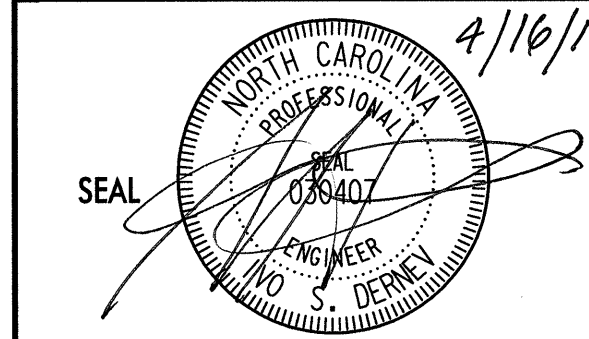
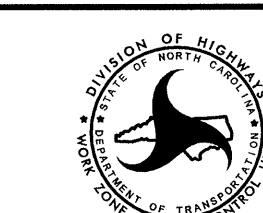
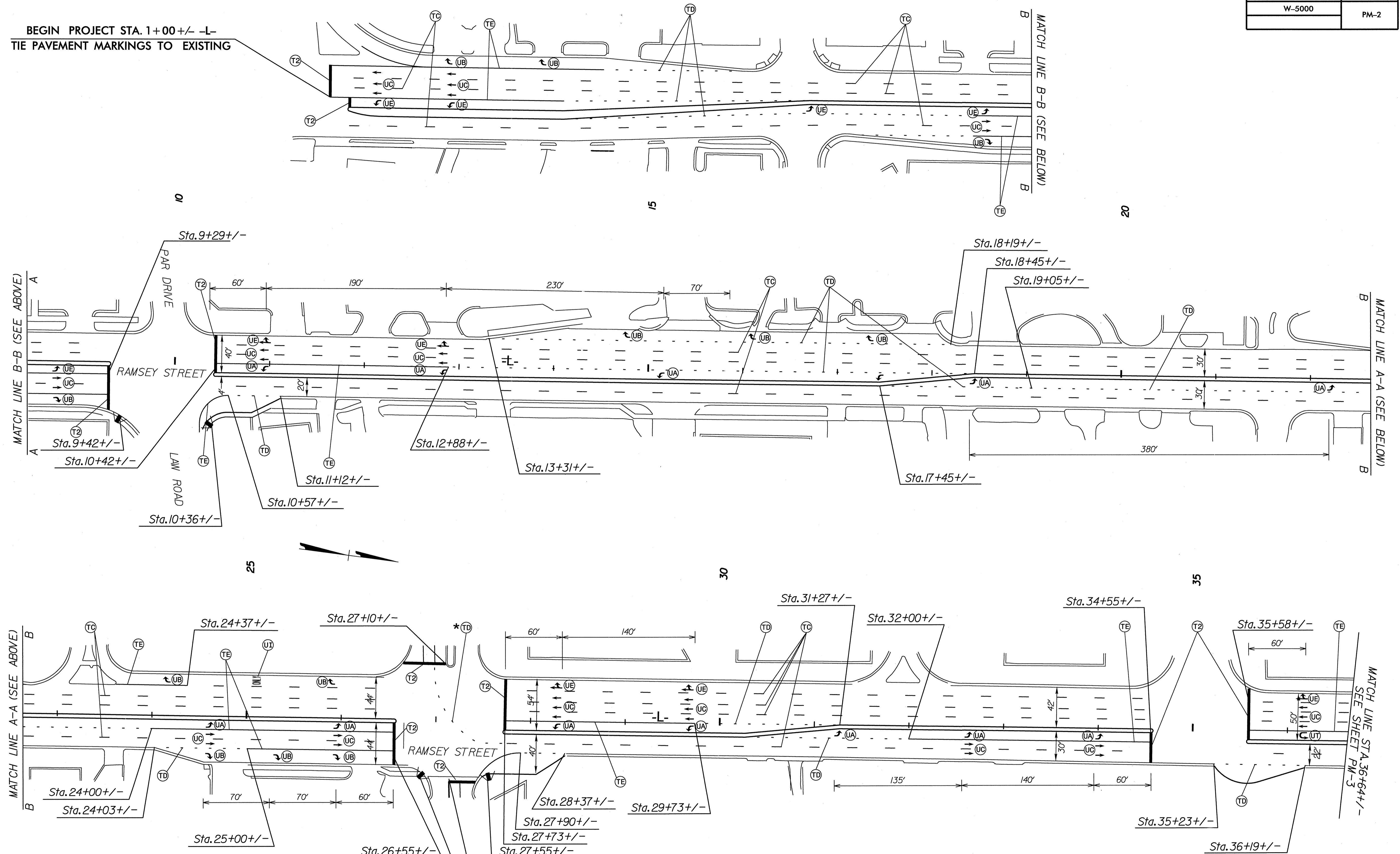

**PAVEMENT MARKING LINES**

- TC - THERMOPLASTIC (4" WHITE, 120 MILS)
- TD - THERMOPLASTIC (4" WHITE, 120 MILS)
- TE - THERMOPLASTIC (4" WHITE, 120 MILS)
- TQ - THERMOPLASTIC (8" WHITE, 90 MILS)
- TV - THERMOPLASTIC (8" WHITE, 120 MILS)
- T2 - THERMOPLASTIC (24" WHITE, 120 MILS)
- 4" X 10' SKIP LINES
- 4" X 2' MINI-SKIP LINES
- SOLID LANE LINE
- DIAGONAL LINE
- CROSSWALK LINE
- STOP BAR
- \* USE 8' SPACING BETWEEN MINI-SKIPS AT THE INTERSECTION.

**PAVEMENT MARKING SYMBOLS**

- UA - THERMOPLASTIC (LEFT TURN ARROW)
- UB - THERMOPLASTIC (RIGHT TURN ARROW)
- UC - THERMOPLASTIC (STRAIGHT ARROW)
- UE - THERMOPLASTIC (COMBINATION STRAIGHT AND RIGHT TURN ARROW)
- UI - THERMOPLASTIC (ALPHANUMERIC CHARACTER)
- UT - THERMOPLASTIC (U-TURN ARROW)

APPROVED: \_\_\_\_\_ DATE: 02/12/10

SEAL

SCALE: \_\_\_\_\_

DATE: 01/09

DWG. BY: \_\_\_\_\_

DESIGN BY: I. DERNEV

REVIEWED BY: \_\_\_\_\_

SEAL NOT VALID UNLESS SIGNED AND DATED

**PAVEMENT MARKING PLANS**

REVISIONS	
01/10	

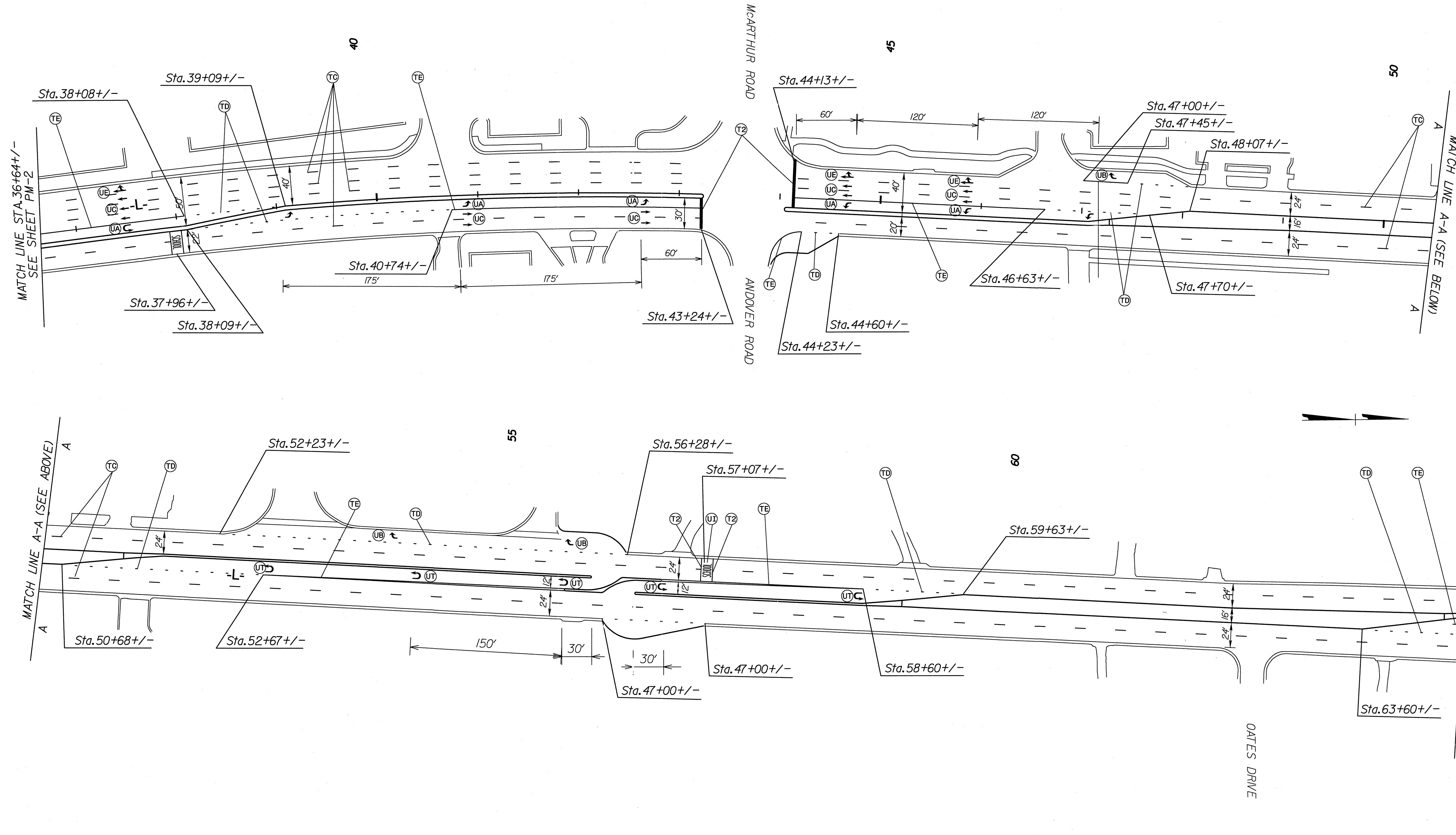

**PAVEMENT MARKING LINES**

- |  |                         |
|--|-------------------------|
| TC - THERMOPLASTIC (4" WHITE, 120 MILS)  | 4" X 10' SKIP LINES     |
| TD - THERMOPLASTIC (4" WHITE, 120 MILS)  | 4" X 2' MINI-SKIP LINES |
| TE - THERMOPLASTIC (4" WHITE, 120 MILS)  | SOLID LANE LINE         |
| TQ - THERMOPLASTIC (8" WHITE, 90 MILS)   | DIAGONAL LINE           |
| TV - THERMOPLASTIC (8" WHITE, 120 MILS)  | CROSSWALK LINE          |
| T2 - THERMOPLASTIC (24" WHITE, 120 MILS) | STOP BAR                |

**PAVEMENT MARKING SYMBOLS**

- |  |
|--|
| UA - THERMOPLASTIC (LEFT TURN ARROW)                           |
| UB - THERMOPLASTIC (RIGHT TURN ARROW)                          |
| UC - THERMOPLASTIC (STRAIGHT ARROW)                            |
| UE - THERMOPLASTIC (COMBINATION STRAIGHT AND RIGHT TURN ARROW) |
| UI - THERMOPLASTIC (ALPHANUMERIC CHARACTERS)                   |
| UT - THERMOPLASTIC (U-TURN ARROW)                              |

APPROVED: \_\_\_\_\_ DATE: 03/12/10

SEAL

SEAL NOT VALID UNLESS SIGNED AND DATED

**PAVEMENT MARKING PLANS**

SCALE: \_\_\_\_\_  
 DATE: 01/09  
 DWG. BY: \_\_\_\_\_  
 DESIGN BY: I. DERNEV  
 REVIEWED BY: \_\_\_\_\_



REVISIONS	
01/10	

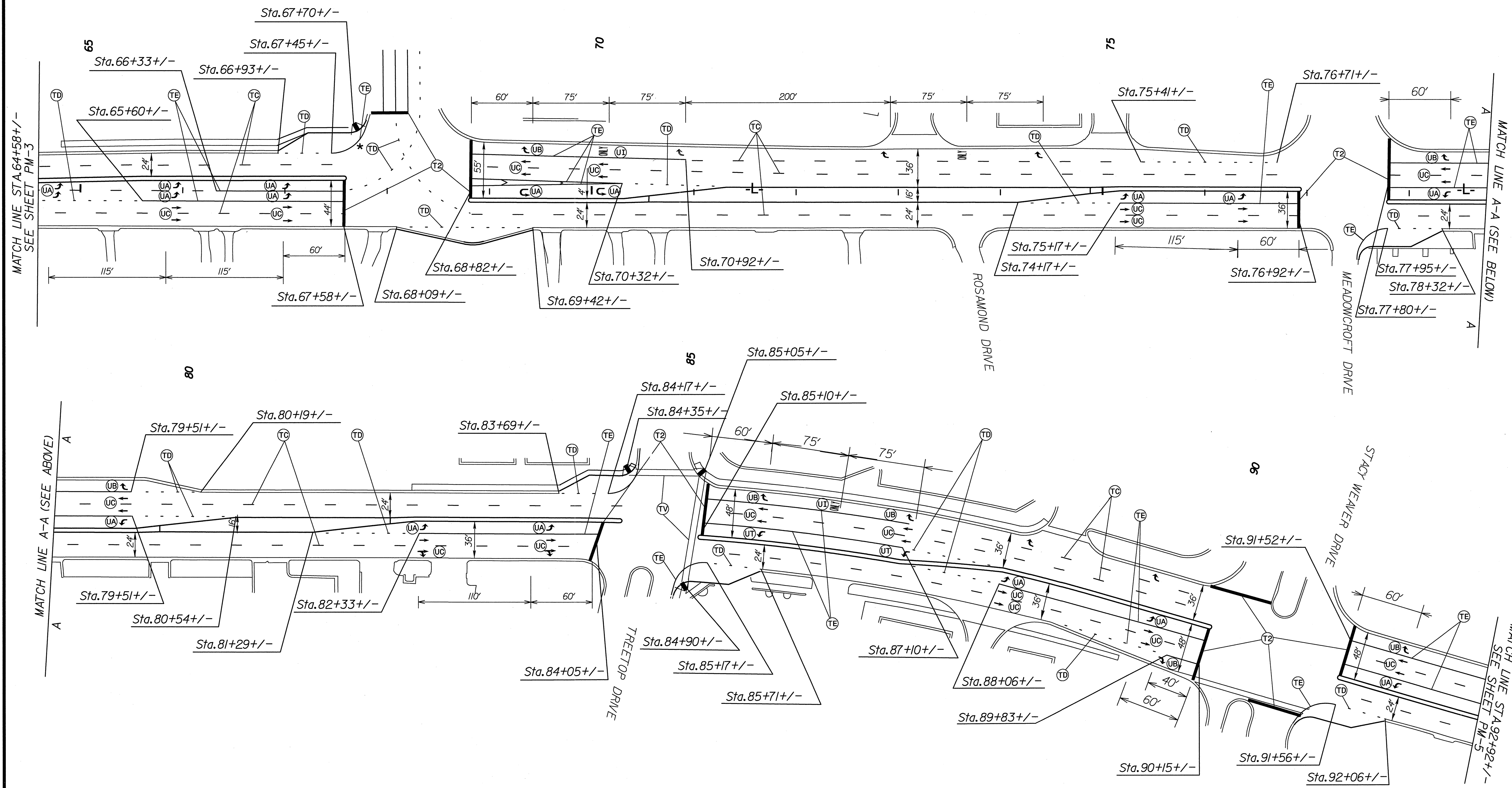
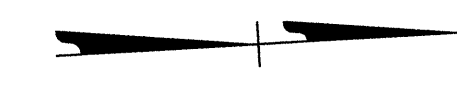

**PAVEMENT MARKING LINES**

- TC - THERMOPLASTIC (4" WHITE, 120 MILS)
- TD - THERMOPLASTIC (4" WHITE, 120 MILS)
- TE - THERMOPLASTIC (4" WHITE, 120 MILS)
- TQ - THERMOPLASTIC (8" WHITE, 90 MILS)
- TV - THERMOPLASTIC (8" WHITE, 120 MILS)
- T2 - THERMOPLASTIC (24" WHITE, 120 MILS)
- \* USE 8' SPACING BETWEEN MINI-SKIPS AT THE INTERSECTION.
- 4" X 10' SKIP LINES
- 4" X 2' MINI-SKIP LINES
- SOLID LANE LINE
- DIAGONAL LINE
- CROSSWALK LINE
- STOP BAR

**PAVEMENT MARKING SYMBOLS**

- UA - THERMOPLASTIC (LEFT TURN ARROW)
- UB - THERMOPLASTIC (RIGHT TURN ARROW)
- UC - THERMOPLASTIC (STRAIGHT ARROW)
- UE - THERMOPLASTIC (COMBINATION STRAIGHT AND RIGHT TURN ARROW)
- UI - THERMOPLASTIC (ALPHANUMERIC CHARACTERS)
- UT - THERMOPLASTIC (U-TURN ARROW)

APPROVED: \_\_\_\_\_ DATE: 03/12/10

SEAL

NO. 101987  
I. DERNEV  
ENGINEER  
STATE OF NORTH CAROLINA

SEAL NOT VALID UNLESS SIGNED AND DATED

**PAVEMENT MARKING PLANS**

SCALE:	DATE: 01/09		REVISIONS
DWG. BY:	DESIGN BY: I. DERNEV		01/10
DESIGN BY:	REVIEWED BY:		
REVIEWED BY:			

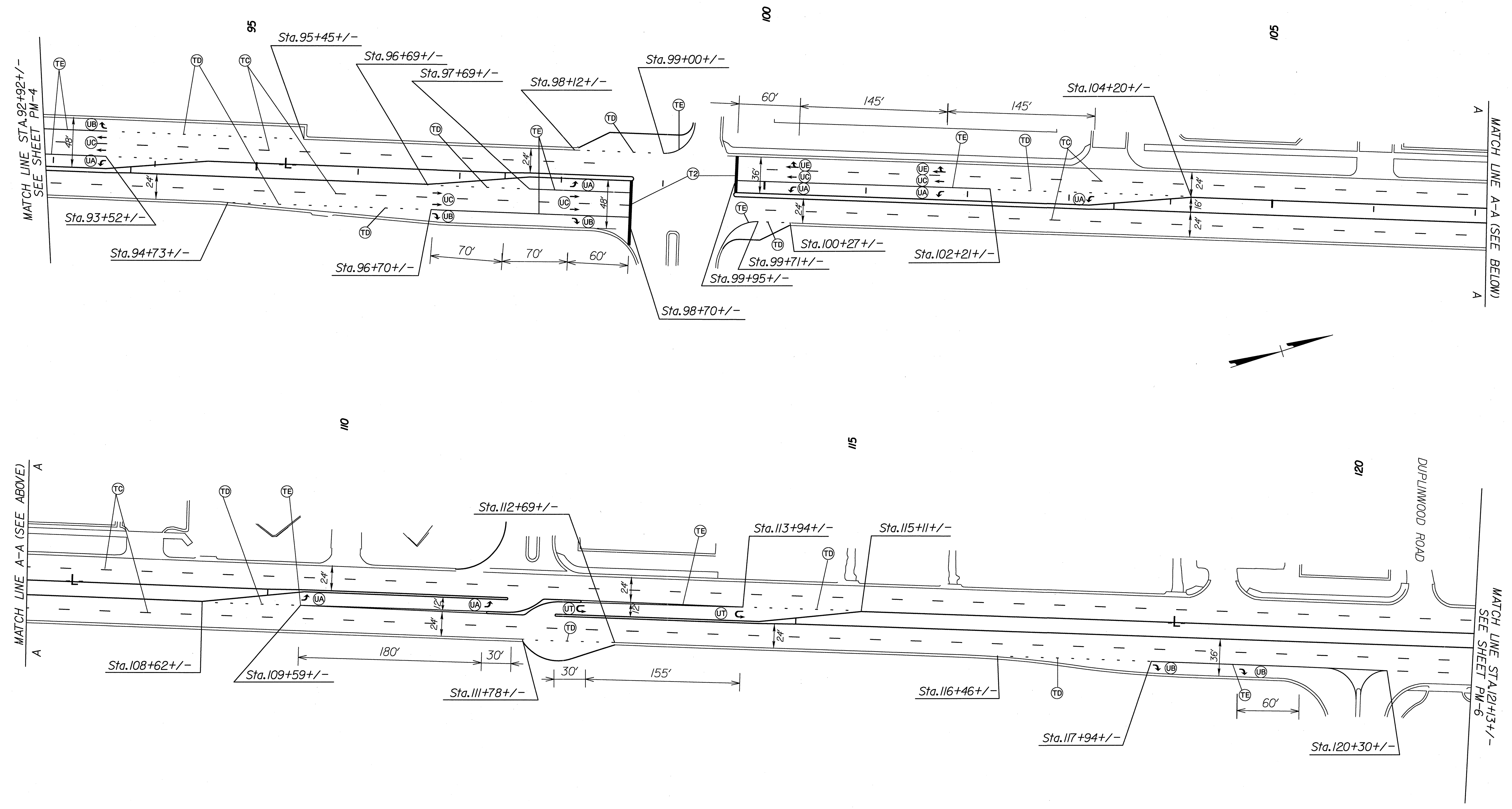

**PAVEMENT MARKING LINES**

- |  |                         |
|--|-------------------------|
| TC - THERMOPLASTIC (4" WHITE, 120 MILS)  | 4" X 10' SKIP LINES     |
| TD - THERMOPLASTIC (4" WHITE, 120 MILS)  | 4" X 2' MINI-SKIP LINES |
| TE - THERMOPLASTIC (4" WHITE, 120 MILS)  | SOLID LANE LINE         |
| TQ - THERMOPLASTIC (8" WHITE, 90 MILS)   | DIAGONAL LINE           |
| TV - THERMOPLASTIC (8" WHITE, 120 MILS)  | CROSSWALK LINE          |
| T2 - THERMOPLASTIC (24" WHITE, 120 MILS) | STOP BAR                |

**PAVEMENT MARKING SYMBOLS**

- |  |
|--|
| UA - THERMOPLASTIC (LEFT TURN ARROW)                           |
| UB - THERMOPLASTIC (RIGHT TURN ARROW)                          |
| UC - THERMOPLASTIC (STRAIGHT ARROW)                            |
| UE - THERMOPLASTIC (COMBINATION STRAIGHT AND RIGHT TURN ARROW) |
| UT - THERMOPLASTIC (U-TURN ARROW)                              |

APPROVED: \_\_\_\_\_ DATE: 02/12/10

SEAL

SEAL NOT VALID UNLESS SIGNED AND DATED

**PAVEMENT MARKING PLANS**

SCALE: \_\_\_\_\_  
 DATE: 01/09  
 DWG. BY: \_\_\_\_\_  
 DESIGN BY: I. DERNEV  
 REVIEWED BY: \_\_\_\_\_



REVISIONS	
01/10	

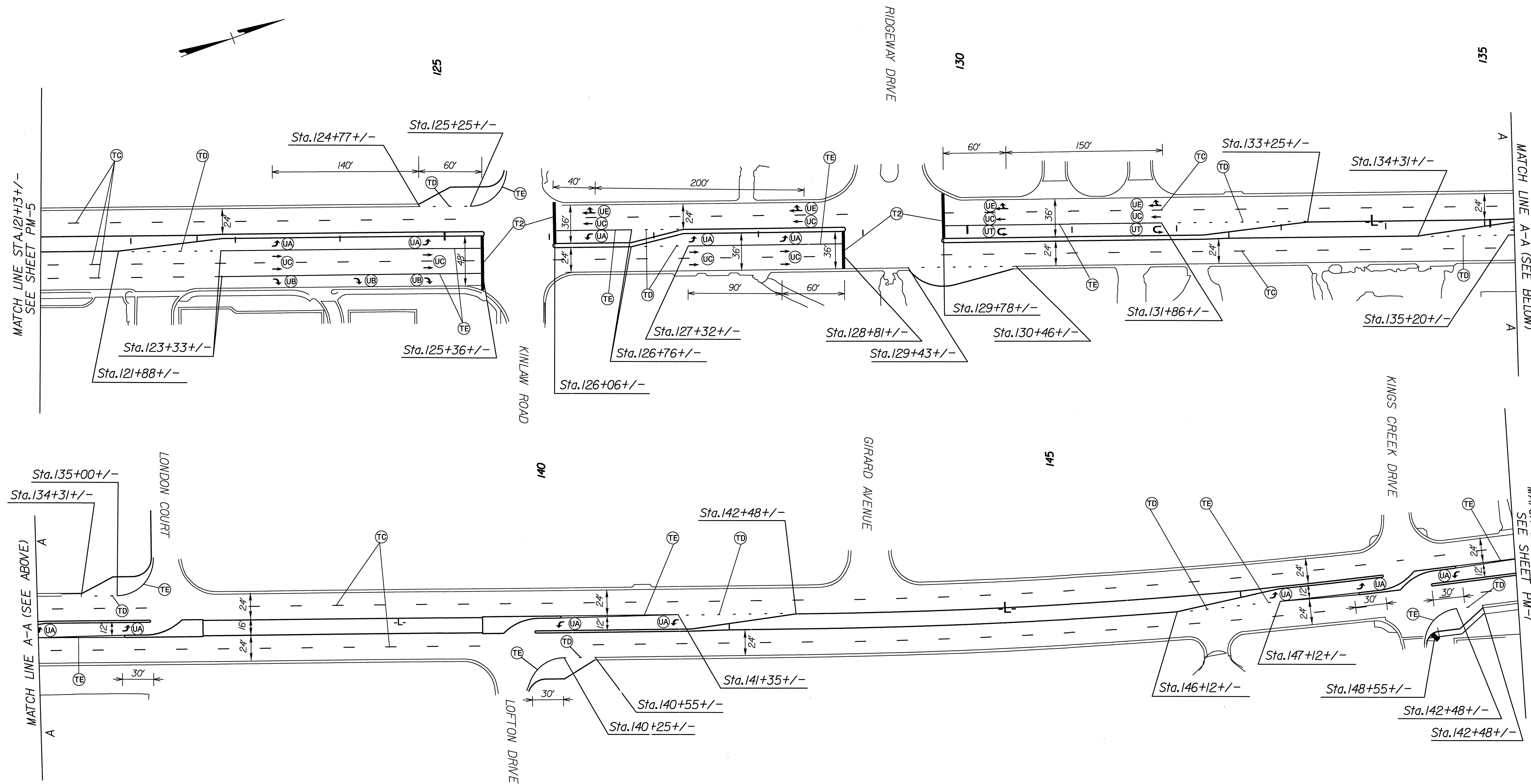

**PAVEMENT MARKING LINES**

- |  |                         |
|--|-------------------------|
| TC - THERMOPLASTIC (4" WHITE, 120 MILS)  | 4" X 10' SKIP LINES     |
| TD - THERMOPLASTIC (4" WHITE, 120 MILS)  | 4" X 2' MINI-SKIP LINES |
| TE - THERMOPLASTIC (4" WHITE, 120 MILS)  | SOLID LANE LINE         |
| TQ - THERMOPLASTIC (8" WHITE, 90 MILS)   | DIAGONAL LINE           |
| TV - THERMOPLASTIC (8" WHITE, 120 MILS)  | CROSSWALK LINE          |
| T2 - THERMOPLASTIC (24" WHITE, 120 MILS) | STOP BAR                |

**PAVEMENT MARKING SYMBOLS**

- |  |
|--|
| UA - THERMOPLASTIC (LEFT TURN ARROW)                           |
| UB - THERMOPLASTIC (RIGHT TURN ARROW)                          |
| UC - THERMOPLASTIC (STRAIGHT ARROW)                            |
| UE - THERMOPLASTIC (COMBINATION STRAIGHT AND RIGHT TURN ARROW) |
| UT - THERMOPLASTIC (U-TURN ARROW)                              |

APPROVED: \_\_\_\_\_ DATE: 02/12/10

SEAL

SEAL NOT VALID UNLESS SIGNED AND DATED

**PAVEMENT MARKING PLANS**

SCALE: \_\_\_\_\_  
 DATE: 01/09  
 DWG. BY: \_\_\_\_\_  
 DESIGN BY: I. DERNEV  
 REVIEWED BY: \_\_\_\_\_

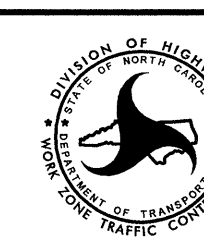

REVISIONS	
01/10	

CADD FILE

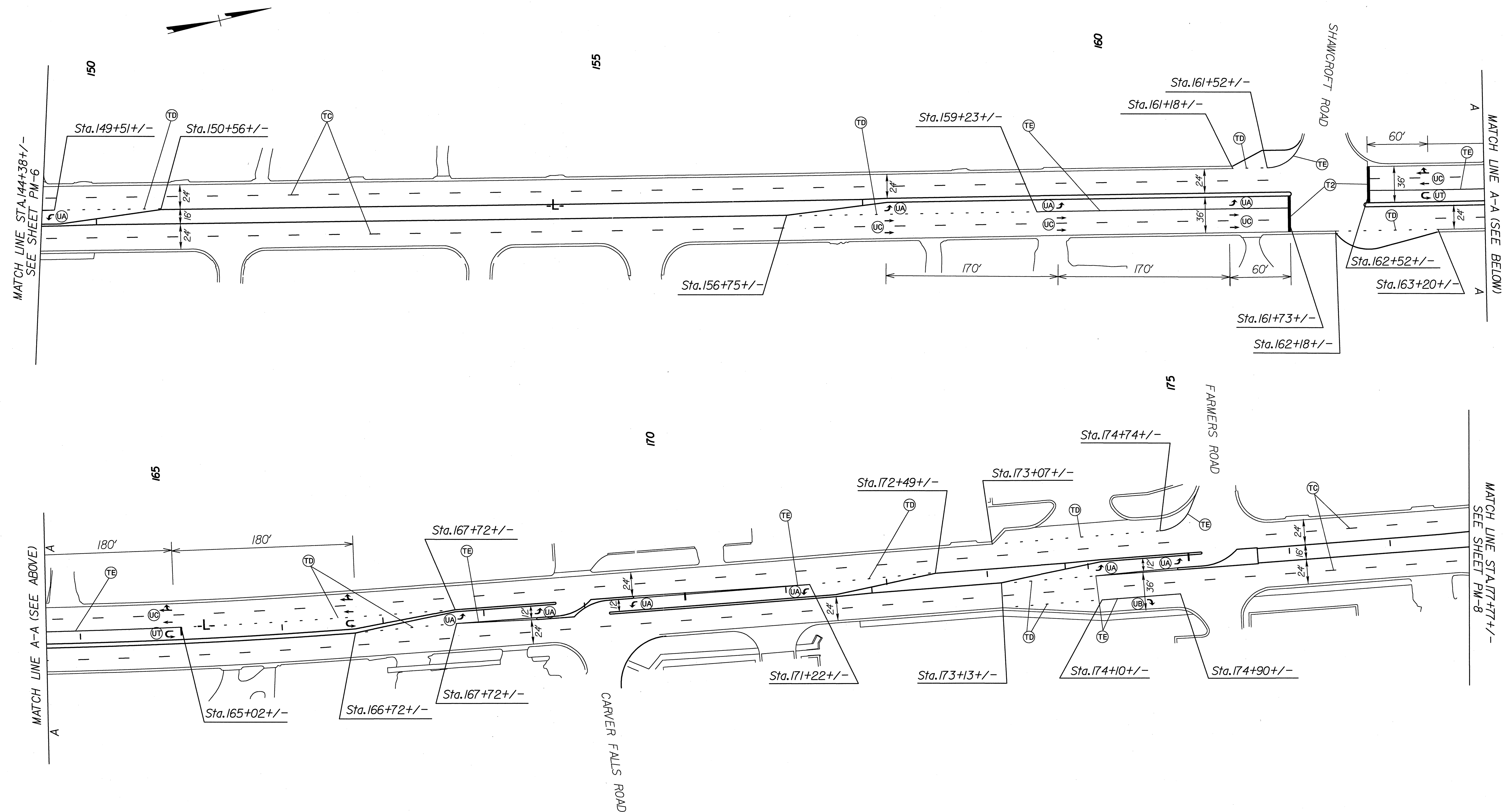

**PAVEMENT MARKING LINES**

- |  |                         |
|--|-------------------------|
| TC - THERMOPLASTIC (4" WHITE, 120 MILS)  | 4" X 10' SKIP LINES     |
| TD - THERMOPLASTIC (4" WHITE, 120 MILS)  | 4" X 2' MINI-SKIP LINES |
| TE - THERMOPLASTIC (4" WHITE, 120 MILS)  | SOLID LANE LINE         |
| TQ - THERMOPLASTIC (8" WHITE, 90 MILS)   | DIAGONAL LINE           |
| TV - THERMOPLASTIC (8" WHITE, 120 MILS)  | CROSSWALK LINE          |
| T2 - THERMOPLASTIC (24" WHITE, 120 MILS) | STOP BAR                |

**PAVEMENT MARKING SYMBOLS**

- |  |
|--|
| UA - THERMOPLASTIC (LEFT TURN ARROW)                           |
| UB - THERMOPLASTIC (RIGHT TURN ARROW)                          |
| UC - THERMOPLASTIC (STRAIGHT ARROW)                            |
| UE - THERMOPLASTIC (COMBINATION STRAIGHT AND RIGHT TURN ARROW) |

APPROVED: \_\_\_\_\_ DATE: 03/12/10

SEAL

SEAL NOT VALID UNLESS SIGNED AND DATED

**PAVEMENT MARKING PLANS**

SCALE:	DATE: 01/09		REVISIONS
DWG. BY:	DESIGN BY: I. DERNEY		01/10
REVIEWED BY:			

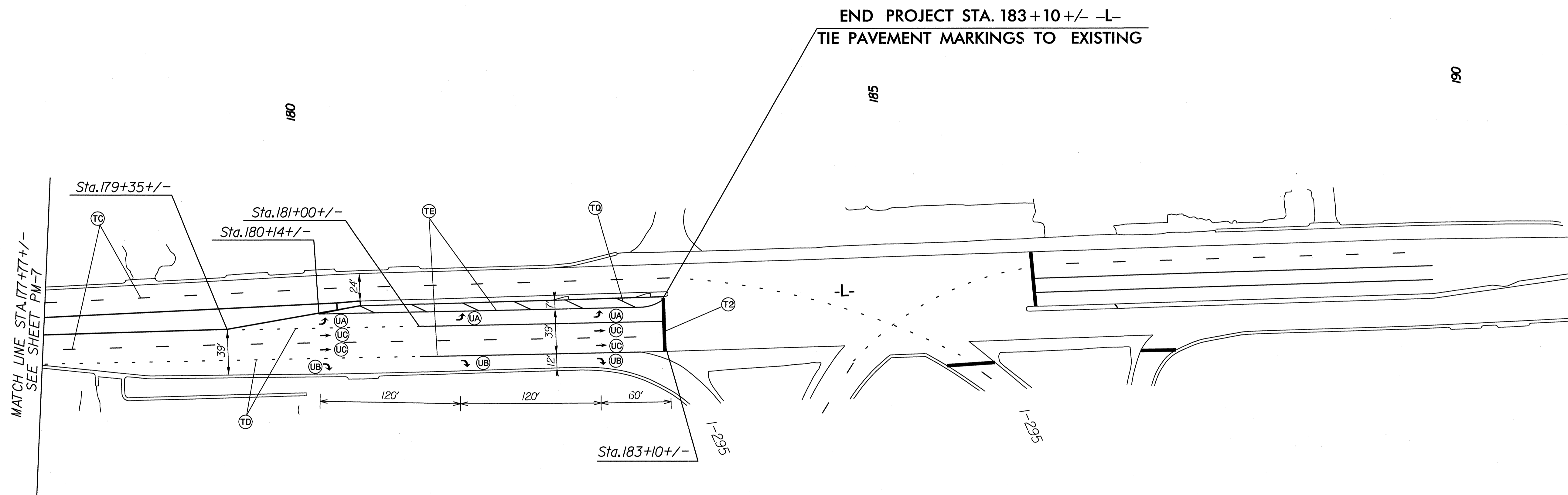

**PAVEMENT MARKING LINES**

- |  |                         |
|--|-------------------------|
| TC - THERMOPLASTIC (4" WHITE, 120 MILS)  | 4" X 10' SKIP LINES     |
| TD - THERMOPLASTIC (4" WHITE, 120 MILS)  | 4" X 2' MINI-SKIP LINES |
| TE - THERMOPLASTIC (4" WHITE, 120 MILS)  | SOLID LANE LINE         |
| TQ - THERMOPLASTIC (8" WHITE, 90 MILS)   | DIAGONAL LINE           |
| TV - THERMOPLASTIC (8" WHITE, 120 MILS)  | CROSSWALK LINE          |
| T2 - THERMOPLASTIC (24" WHITE, 120 MILS) | STOP BAR                |

**PAVEMENT MARKING SYMBOLS**

- |   |
|---|
| UA - THERMOPLASTIC (LEFT TURN ARROW)                          |
| UB - THERMOPLASTIC (RIGHT TURN ARROW)                         |
| UC - THERMOPLASTIC (STRAIGHT ARROW)                           |
| U - THERMOPLASTIC (COMBINATION STRAIGHT AND RIGHT TURN ARROW) |

APPROVED: _____	DATE: _____	<b>PAVEMENT MARKING PLANS</b>	
		DATE: 01/09	01/10
DWG. BY: _____	DESIGN BY: I. DERNEY		
REVIEWED BY: _____	SEAL	<small>SEAL NOT VALID UNLESS SIGNED AND DATED</small>	