

FINAL PAVEMENT MARKING SCHEDULE

SYMBOL	DESCRIPTION	SYMBOL	DESCRIPTION
FINAL PAVEMENT MARKINGS			
	PAINT (4")		THERMOPLASTIC(4", 90 MILS)
PA	WHITE EDGELINE	TA	WHITE EDGELINE
PB	YELLOW EDGELINE	TB	YELLOW EDGELINE
PC	10 FT. WHITE SKIP		
PD	2 FT. WHITE MINISKIP		THERMOPLASTIC(4", 120 MILS)
PE	WHITE SOLID LANE LINE	TC	10 FT. WHITE SKIP
PH	YELLOW SINGLE CENTER	TD	2 FT. WHITE MINISKIP
PI	YELLOW DOUBLE CENTER	TE	WHITE SOLID LANE LINE
		TH	YELLOW SINGLE CENTER
		TI	YELLOW DOUBLE CENTER
	PAINT(8")		THERMOPLASTIC(8", 90 MILS)
PR	WHITE GORELINE	TP	WHITE GORELINE
PS	WHITE DIAGONAL	TQ	WHITE DIAGONAL
PV	YELLOW DIAGONAL	TT	YELLOW DIAGONAL
	PAINT(24")		THERMOPLASTIC(8", 120 MILS)
P4	WHITE STOPBAR	TV	WHITE CROSSWALK LINE
	PAINT PAVEMENT MARKING SYMBOLS		THERMOPLASTIC(24", 120 MILS)
QA	LEFT TURN ARROW	T2	WHITE STOPBAR
QB	RIGHT TURN ARROW		
QC	STRAIGHT ARROW		THERMOPLASTIC PAVEMENT MARKING SYMBOLS (90 MILS)
QD	COMBO. STRAIGHT/LEFT	UA	LEFT TURN ARROW
QE	COMBO. STRAIGHT/RIGHT	UB	RIGHT TURN ARROW
	PAINT PAVEMENT MARKING CHARACTER	UC	STRAIGHT ARROW
QI	ALPHANUMERIC CHAR.	UD	COMBO. STRAIGHT/LEFT
QJ	SHARK TEETH	UE	COMBO. STRAIGHT/RIGHT
			THERMOPLASTIC PAVEMENT MARKING CHARACTER (120 MILS)
		UI	ALPHANUMERIC CHAR.

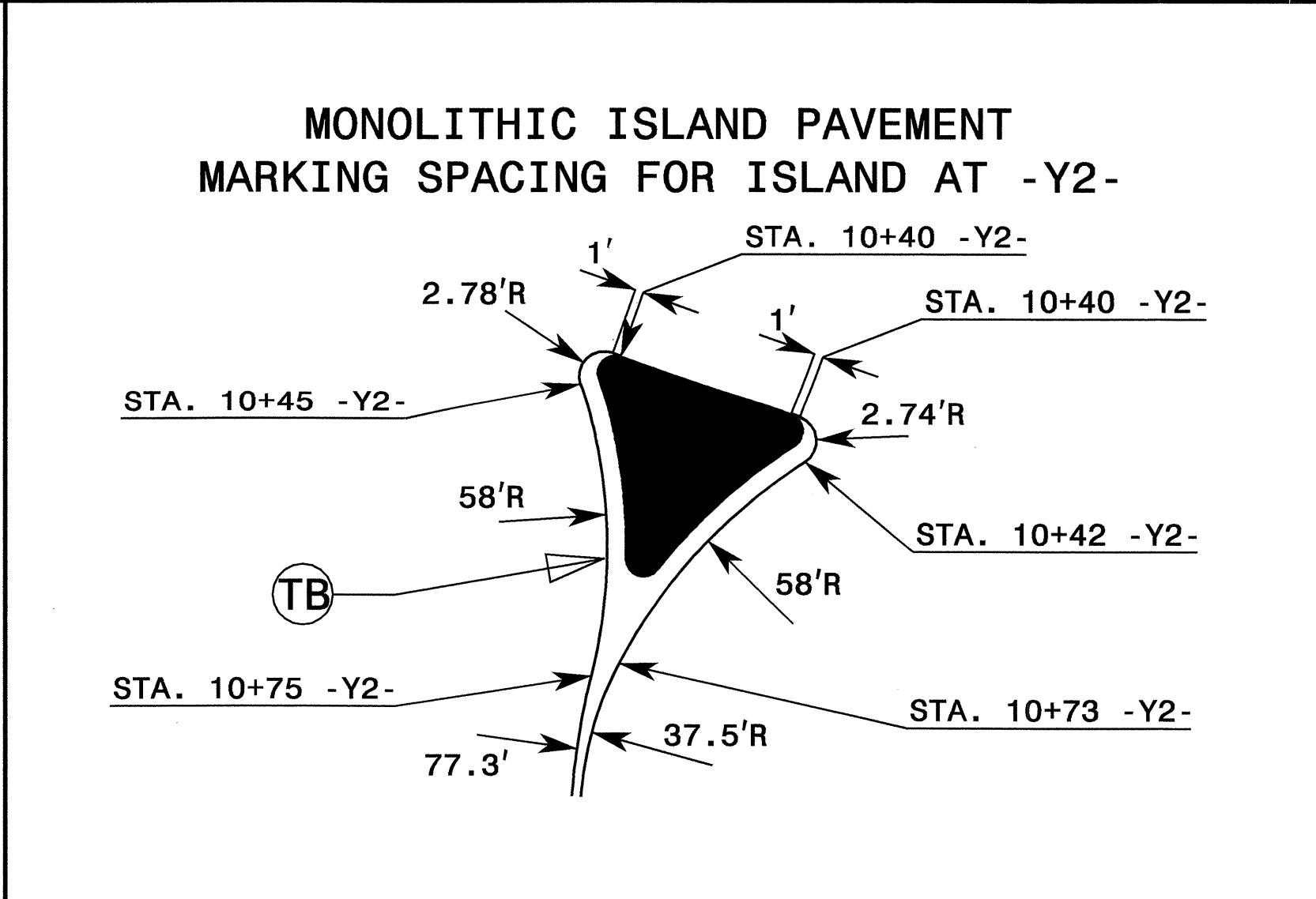
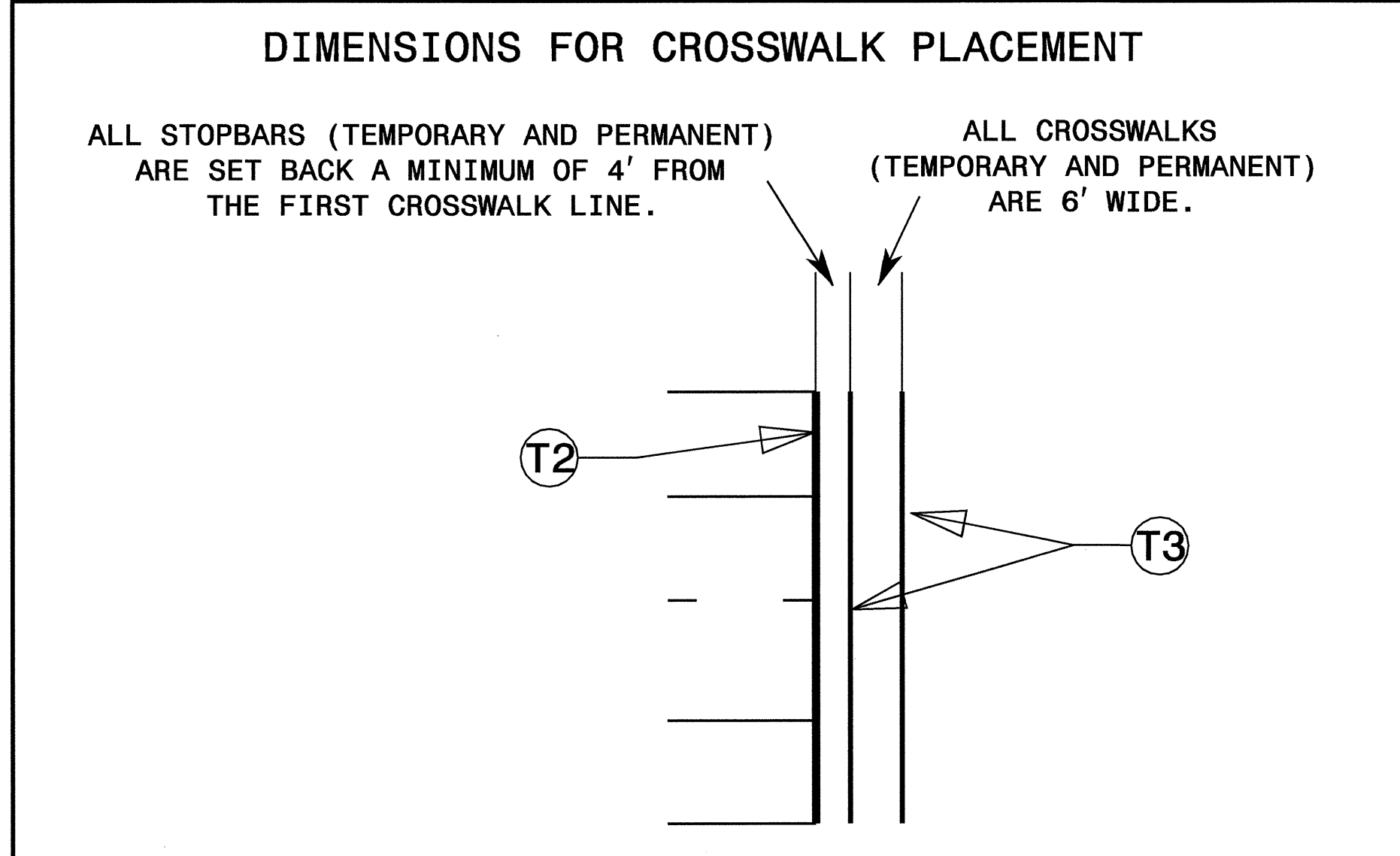
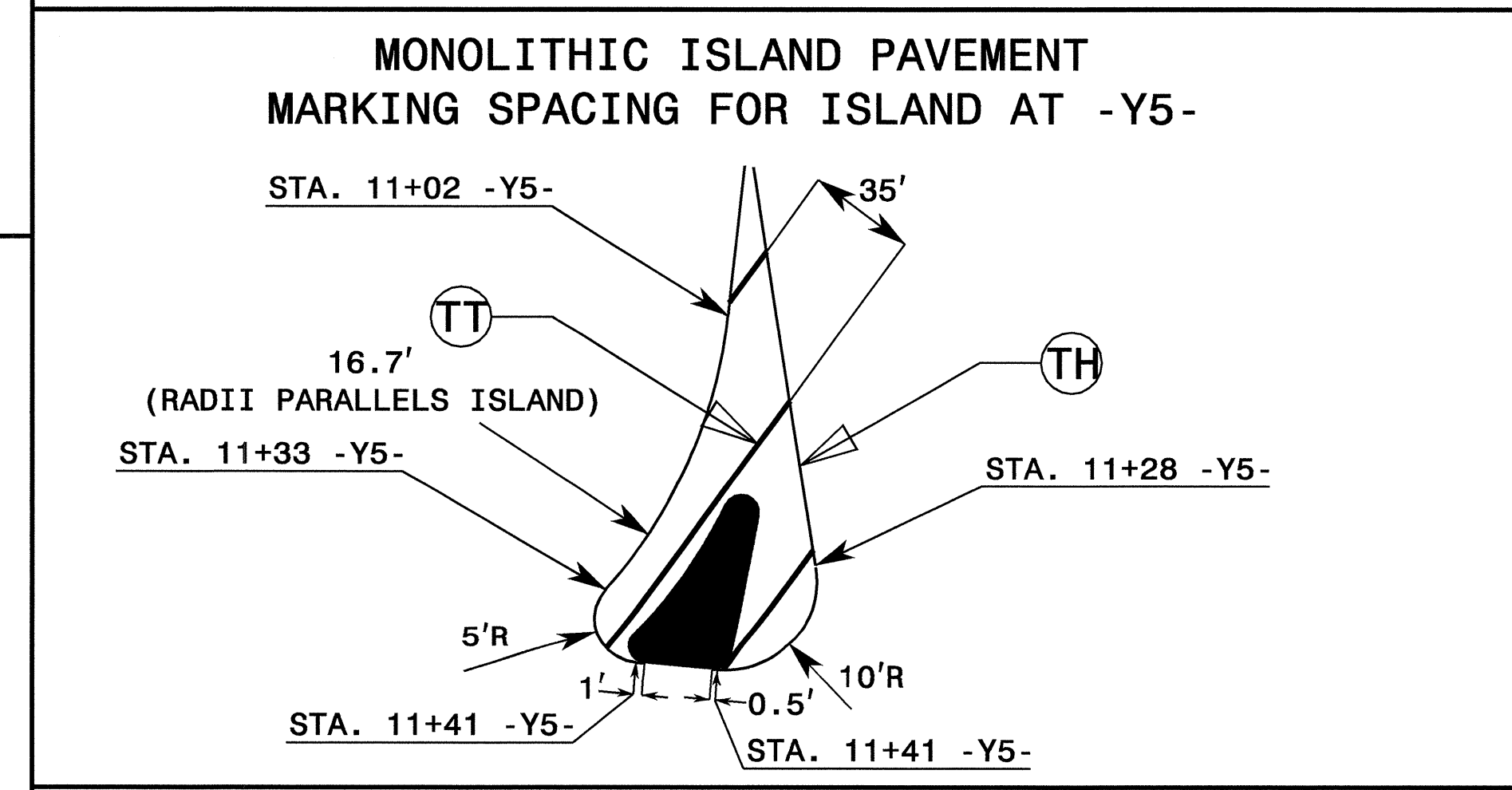
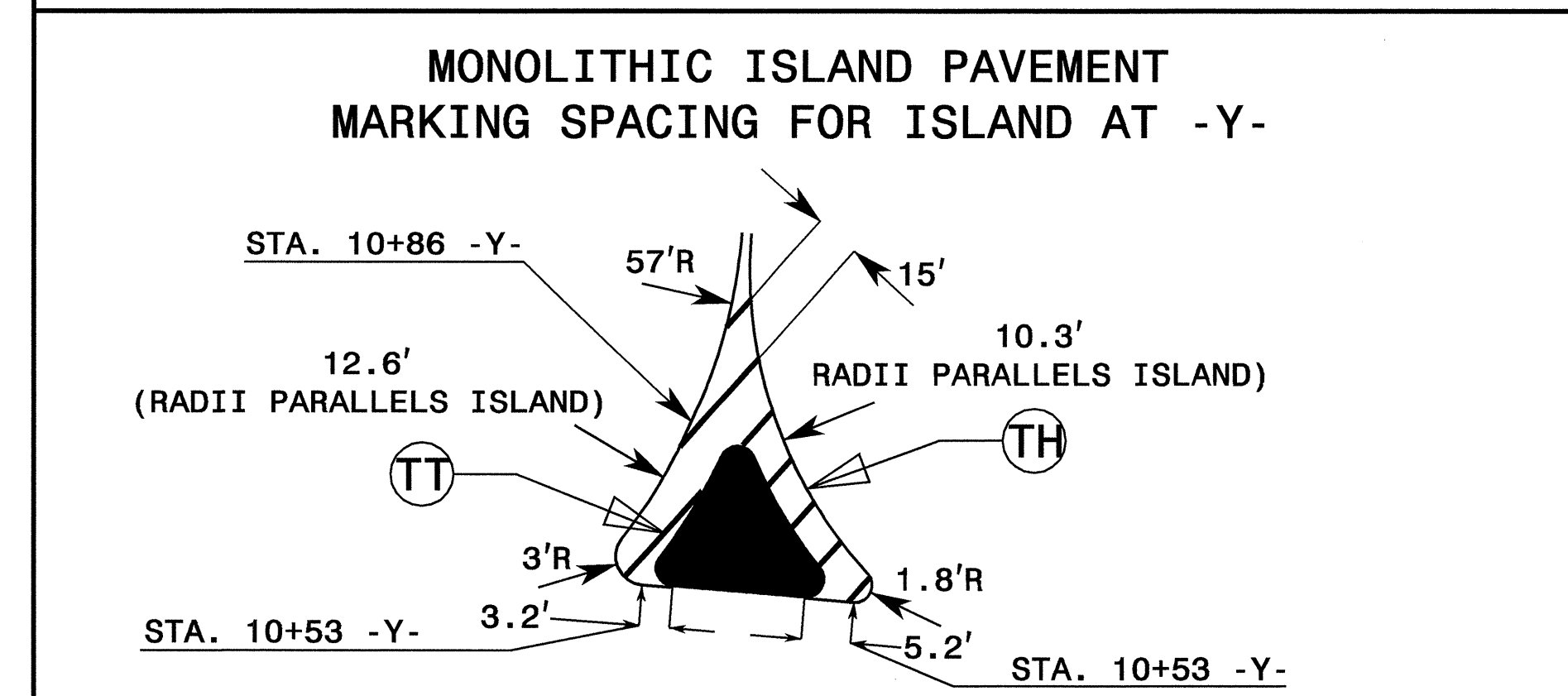
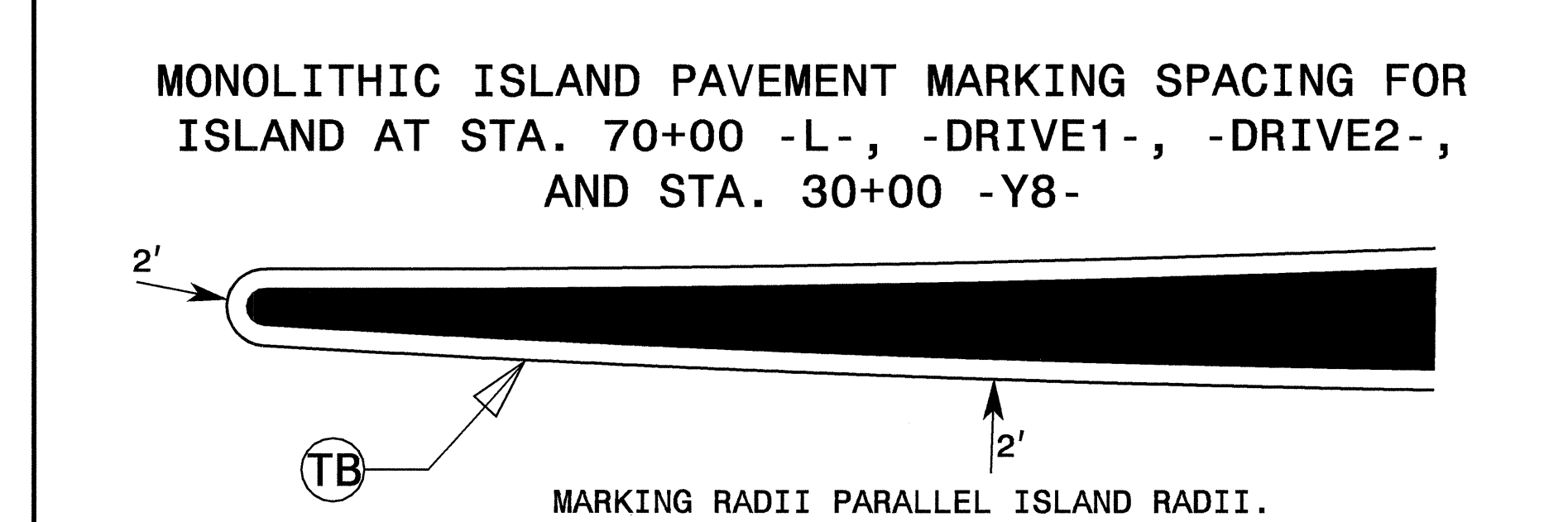
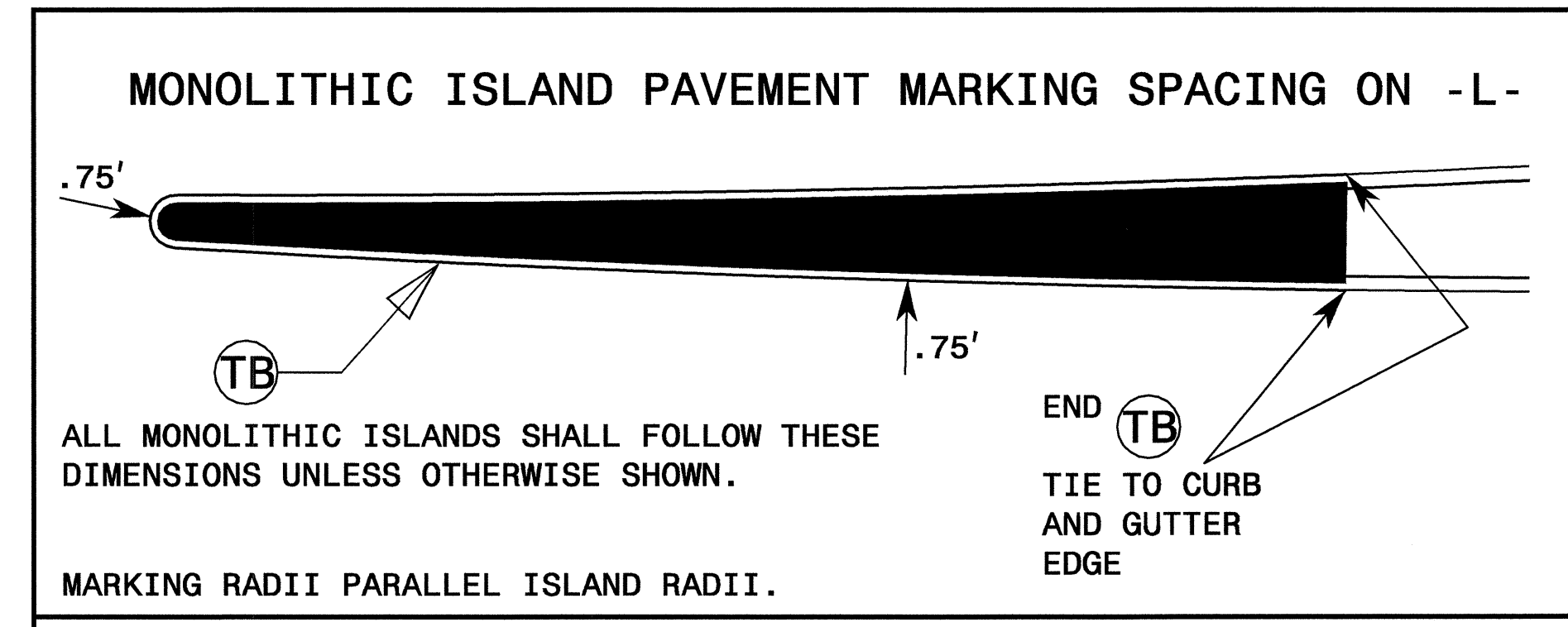

APPROVED: _____	DATE: _____	FINAL PAVEMENT MARKING SCHEDULE	
	SCALE: NONE		REVISIONS
	DATE: 12/08		
	DWG. BY: DAH		
	DESIGN BY: DAH		
	REVIEWED BY: JWW		

05-JAN-2009 07:22
 \DOT\GIS\Projects\U3849\Traffic\TrafficControl\Toc\pmp\U-3849-TC-TCP_PMP_01.dgn
 andys AT MZ124438

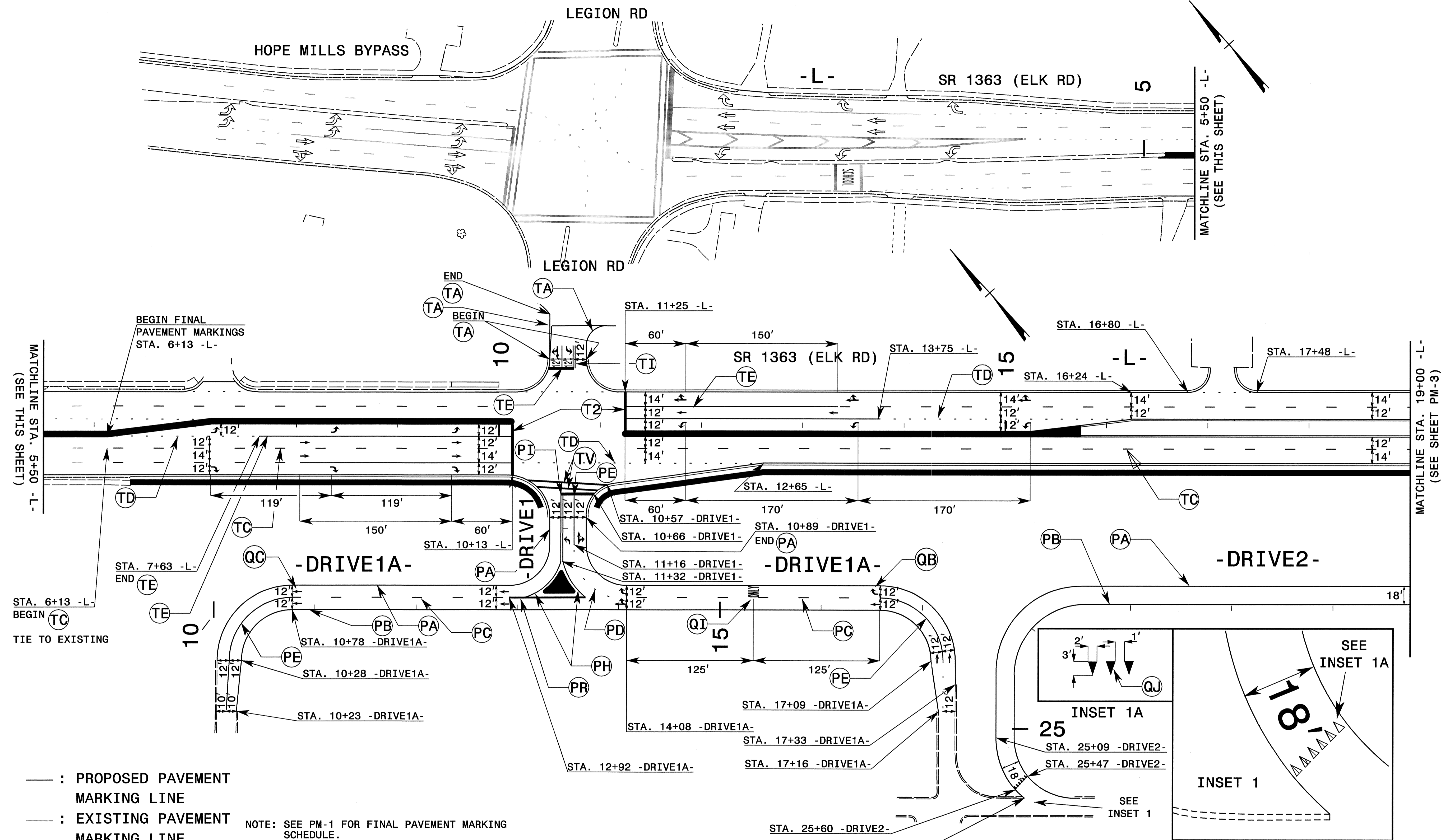

- : PROPOSED PAVEMENT MARKING LINE
 - - - : EXISTING PAVEMENT MARKING LINE
 - ↪ : UA ↪ : UD ↪ : UG PROPOSED PAINT MARKING
 - ↪ : UB ↪ : UE
 - ↪ : UC ↪ : UF
 - ↪ : EXISTING PAVEMENT MARKING SYMBOL
 - ↑ : QC
- NOTE: SEE PM-1 FOR FINAL PAVEMENT MARKING SCHEDULE.
- SYMBOLS (-DRIVE1-, -DRIVE1A-)
- ↪ : QA ↪ : QD ↪ : QG
 - ↪ : QB ↪ : QE
 - ↑ : QC ↪ : QF

APPROVED: _____ DATE: _____	FINAL PAVEMENT MARKING PLAN				
SCALE: NONE DATE: 12/08 DWG. BY: DAH DESIGN BY: DAH REVIEWED BY: JWW	<table border="1"> <tr> <th>REVISIONS</th> </tr> <tr> <td> </td> </tr> <tr> <td> </td> </tr> <tr> <td> </td> </tr> </table>	REVISIONS			
REVISIONS					

05-JAN-2009 07:22
 \DOT\GIS\Projects\U-3849\Traffic\TrafficControl\U-3849-TC-TCP_PMP_02.dgn
 gncgys AT WZ10244138

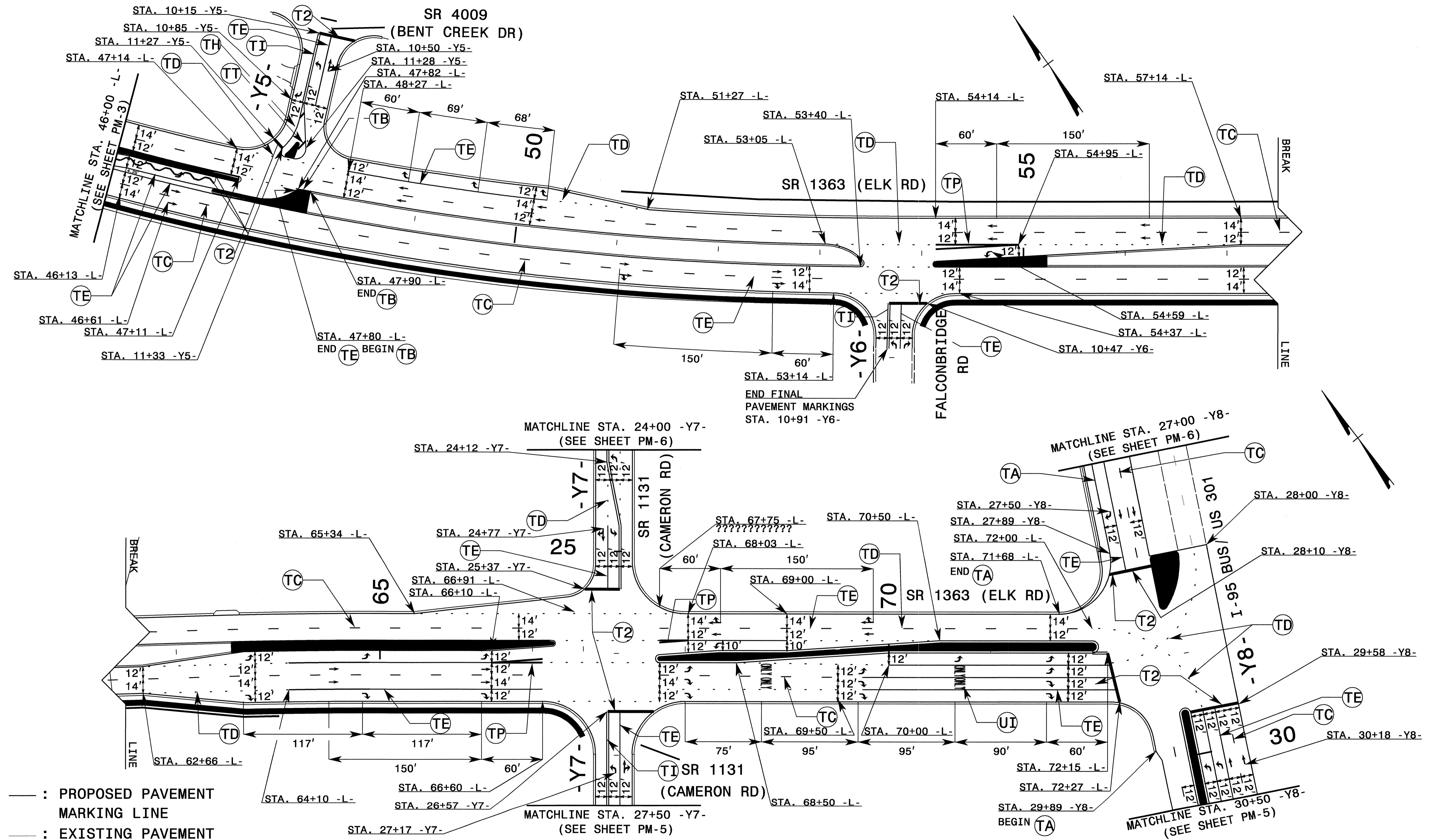

- : PROPOSED PAVEMENT MARKING LINE
- - - : EXISTING PAVEMENT MARKING LINE
- ↖ : UA ↗ : UD ↘ : UG
- ↙ : UB ↖ : UE
- : UC ↗ : UF
- ↪ : EXISTING PAVEMENT MARKING SYMBOL

NOTE: SEE PM-1 FOR FINAL PAVEMENT MARKING SCHEDULE.

APPROVED: <i>J. Woolard</i>	DATE: 1/3/09	FINAL PAVEMENT MARKING PLAN	
SCALE: NONE	DATE: 12/08		REVISIONS
DWG. BY: DAH	DESIGN BY: DAH		
REVIEWED BY: JWJ			

05-JAN-2009 07:22
 \dot\gfrsroot\DOT\USP-03\p\p\projects-u\3849\traffic\control\top\pmp\U-3849-TC.TCP_PMP_04.dgn
 andy@atmz1024138

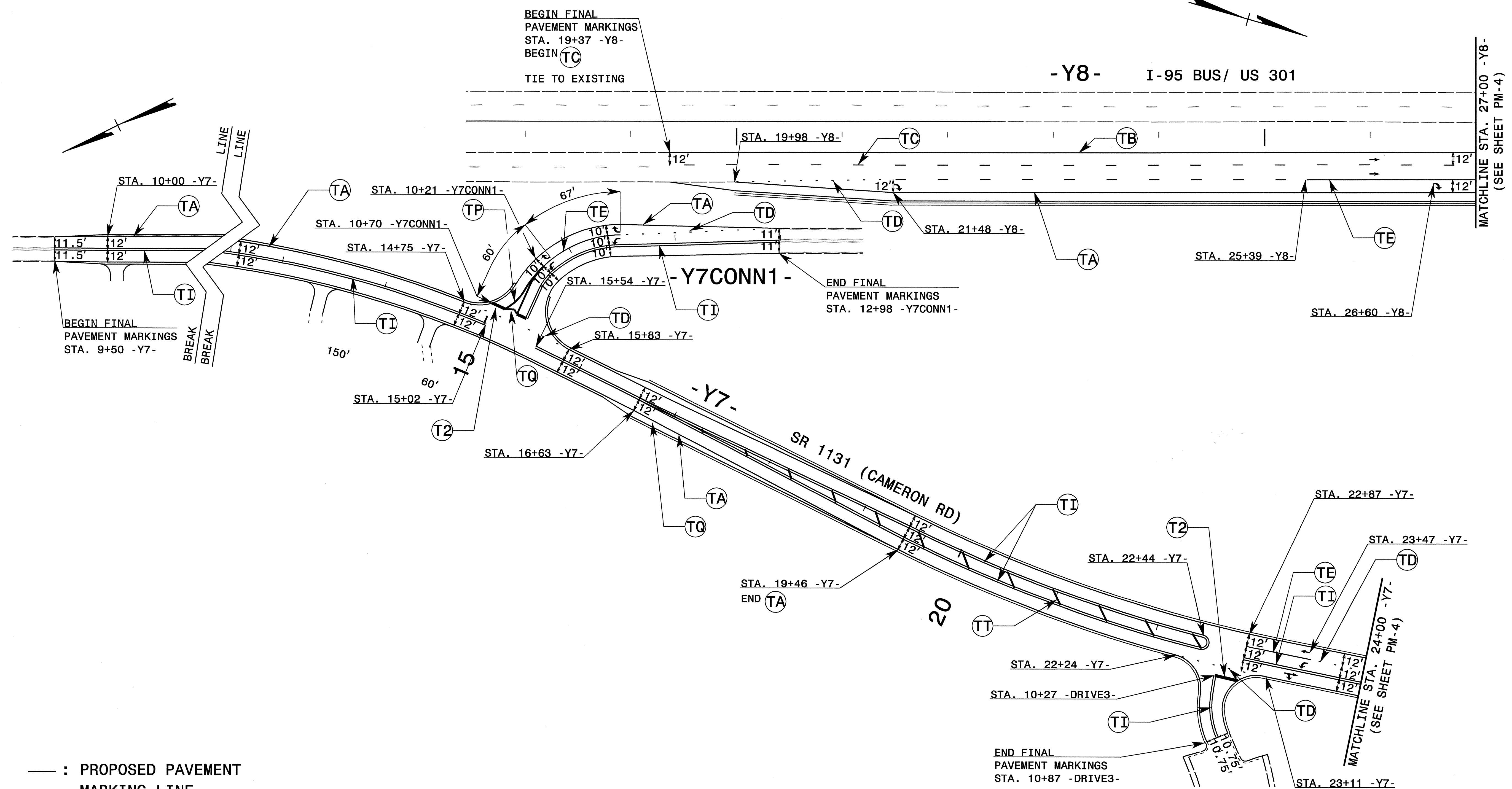

- : PROPOSED PAVEMENT MARKING LINE
- - - : EXISTING PAVEMENT MARKING LINE
- ↖ : UA ↗ : UD ↘ : UG
- ↙ : UB ↖ : UE
- : UC ↗ : UF
- ↪ : EXISTING PAVEMENT MARKING SYMBOL

NOTE: SEE PM-1 FOR FINAL PAVEMENT MARKING SCHEDULE.

APPROVED: _____ DATE: _____	FINAL PAVEMENT MARKING PLAN	
SCALE: NONE		REVISIONS
DATE: 12/08		
DWG. BY: DAH		
DESIGN BY: DAH		
REVIEWED BY: JWW		CADD FILE

05-JAN-2009 07:21
 \\dot\dfsroot\jw\p\projects-u\3849\traffic\control\top\pmp\U-3849.TC.TCP_PMP_05.dgn
 AT: 12/12/08

- : PROPOSED PAVEMENT MARKING LINE
- : EXISTING PAVEMENT MARKING LINE
- ↖ : UA ↗ : UD ↕ : UG
- ↘ : UB ↙ : UE
- ↑ : UC ↔ : UF
- ↶ : EXISTING PAVEMENT MARKING SYMBOL

NOTE: SEE PM-1 FOR FINAL PAVEMENT MARKING SCHEDULE.

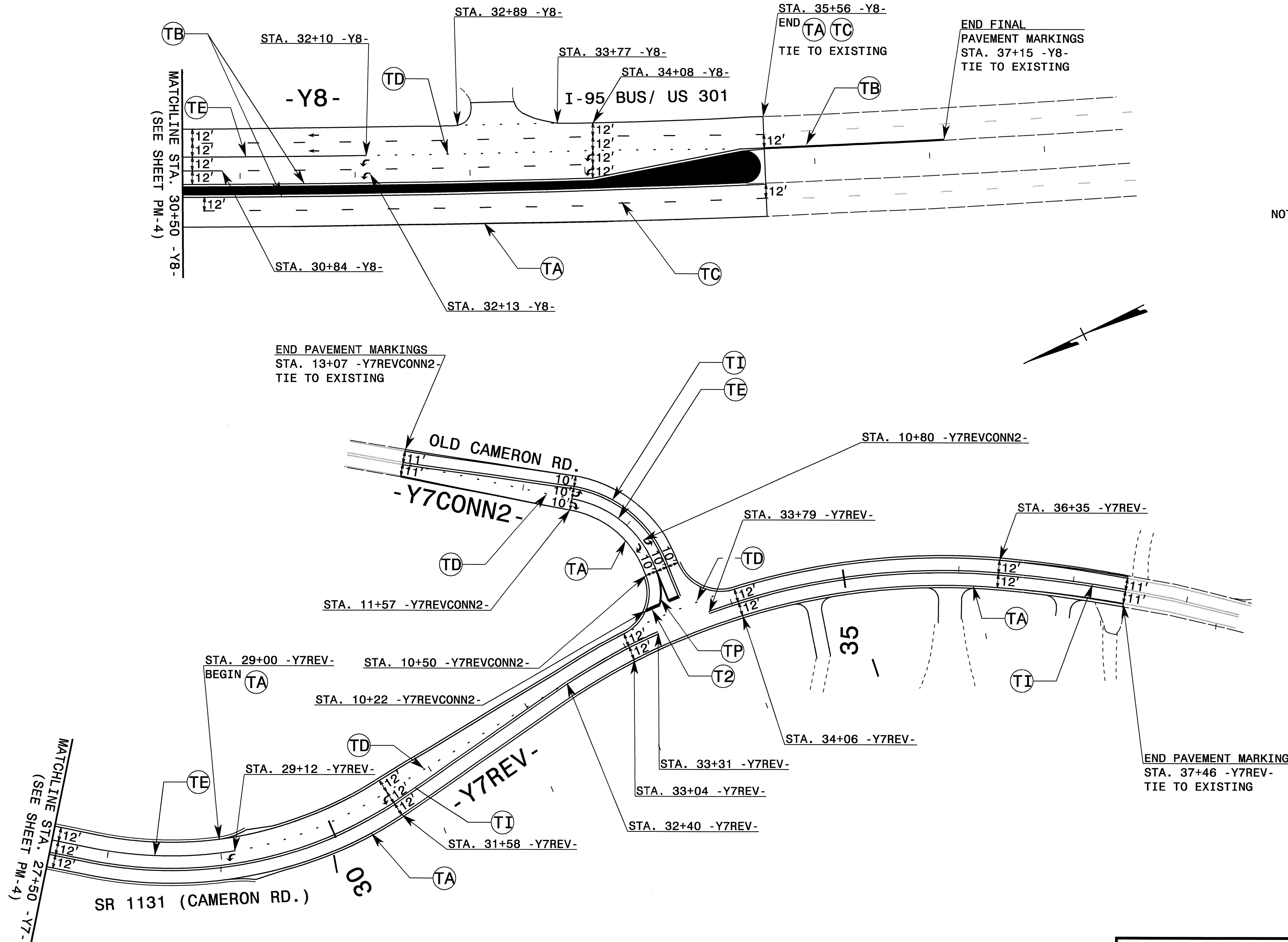

05-JAN-2009 07:21 \\nspr03\ntipprojects\U3849\traffic\control\top\pmp\U-3849_TC_TCP_PMP_06.dgn
 D:\A\3849\traffic\control\top\pmp\U-3849_TC_TCP_PMP_06.dgn
 ahves AT WL TC24738

APPROVED: _____	DATE: _____	FINAL PAVEMENT MARKING PLAN									
SCALE: NONE	DATE: 12/08	<table border="1"> <thead> <tr> <th colspan="2">REVISIONS</th> </tr> </thead> <tbody> <tr> <td> </td> <td> </td> </tr> <tr> <td> </td> <td> </td> </tr> <tr> <td> </td> <td> </td> </tr> </tbody> </table>		REVISIONS							
REVISIONS											
DWG. BY: DAH	DESIGN BY: DAH										
REVIEWED BY: JWW											