

TIP NO. U-3100B	SHEET NO. SIGN-1
APPROVED: _____	
DATE: _____	
SEAL	



**STATE OF NORTH CAROLINA  
DEPARTMENT OF TRANSPORTATION**

**SIGNING PLANS  
ORANGE COUNTY**

**LOCATION: SR 1107(OLD FAYETTEVILLE RD) FROM NC 54 TO  
MCDUGLE MIDDLE SCHOOL IN CARRBORO**

**ROADWAY STANDARD DRAWING**

THE FOLLOWING ROADWAY STANDARDS AS APPEAR IN "ROADWAY STANDARD DRAWINGS" - PROJECT SERVICES UNIT - N.C. DEPARTMENT OF TRANSPORTATION - RALEIGH, N.C., DATED JULY 2006 ARE APPLICABLE TO THIS PROJECT AND BY REFERENCE HEREBY ARE CONSIDERED A PART OF THESE PLANS:

STD. NO.	TITLE
904.10	ORIENTATION OF GROUND MOUNTED SIGNS
904.50	MOUNTING OF TYPE 'D', 'E' AND 'F' SIGNS ON 'U' CHANNEL POSTS

**GENERAL NOTES**

- . SIGNS FURNISHED BY STATE
- . ALL TYPE 'D' SIGNS SHALL BE MOUNTED ON TWO U-CHANNEL POSTS UNLESS OTHERWISE INDICATED ON THE PLANS.
- . IF REMOVAL OR RELOCATION OF SIGNS ON PRIVATE STREET (NON-STATE MAINTAINED) IS REQUIRED DUE TO CONSTRUCTION, THE CONTRACTOR SHALL INFORM THE ENGINEER. THE WORK WILL BE COMPLETED BY OTHERS.
- . SIGNING PLANS DO NOT INCLUDE TEMPORARY CONSTRUCTION SIGNING OR PAVEMENT MARKINGS. SEE TRAFFIC CONTROL PLANS.
- . WHEN NOT STATIONED OR DIMENSIONED ON PLANS, ALL 'E' AND 'F' SIGNS SHALL BE FIELD LOCATED BY THE ENGINEER
- . WHEN EXISTING SIGNS ARE REMOVED AND INSTALLED ON NEW SUPPORTS, THE RE-ERECTION SHALL IMMEDIATELY FOLLOW THE REMOVAL.
- . THE BACKGROUND FOR TYPE E & F SIGNS SHALL BE GRADE C REFLECTIVE SHEETING.
- . SEE ROADWAY PLANS FOR GUARD/GUIDE RAIL DETAILS.
- . DO NOT BEGIN FABRICATION FOR TYPES A & B SIGNS MOUNTED ON OVERHEAD STRUCTURES OR STEEL SUPPORTS UNTIL "S" DIMENSIONS HAVE BEEN FIELD VERIFIED.

**SUMMARY OF QUANTITIES**

ITEM NO.	ITEM DESCRIPTION		QUANTITY	UNIT
DESC. NO.	SECT. NO.			
4072000000	903	SUPPORTS, 3 LB U-CHANNEL .....	572	L.F.
4102000000	904	SIGN ERECTION, TYPE E .....	48	EA.
4155000000	907	DISPOSAL OF SIGN SYSTEM, U-CHANNEL .....	23	EA.

**INDEX**

SHEET NO.	DESCRIPTION
SIGN - 1	SUMMARY OF QUANTITIES & NOTES
SIGN - 2	"E" SHEET
SIGN - 3 - 5	SIGN DETAIL SHEETS

**PLAN PREPARED BY: N.C.D.O.T. SIGNING AND DELINEATION UNIT**

RON KING, P.E. STATE SIGNING & DELINEATION ENGINEER  
STACEY JOHNS SIGNING & DELINEATION DESIGN ENGINEER

**T.I.P.: U-3100B**

**CONTRACT: C202372**

03-AUG-2009 07:54  
 P:\TIP-cole\31008\Treffle\Signing\CADD\Signing Layout Plans\Proj\U-31008\Title.dgn  
 sjohns AT TELCC221642

TIP NO. U-31008	SHEET NO. SIGN-2
APPROVED: _____	
DATE: _____	
SEAL	

402 QUANTITY REQ'D   1  



24 X 30  
R2-1

ONE "U" POST PER SIGN

411 QUANTITY REQ'D   1  



30 X 30  
R5-1

ONE "U" POST PER SIGN

419 QUANTITY REQ'D   2  



30 X 8  
S4-3

MOUNT ABOVE SIGN 402  
IN 1 INSTALLATIONS

MOUNT ABOVE SIGN 453  
IN 1 INSTALLATIONS

435 QUANTITY REQ'D   1  

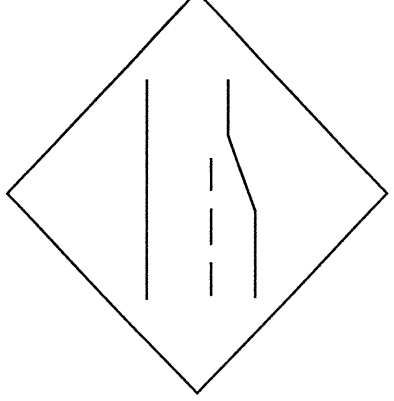

36 X 36  
W4-2(R)

TWO "U" POSTS PER SIGN

463 QUANTITY REQ'D   2  



24" X 6"  
R3-17b

TO BE MOUNTED BELOW SIGN #462  
IN 2 INSTALLATIONS

403 QUANTITY REQ'D   2  

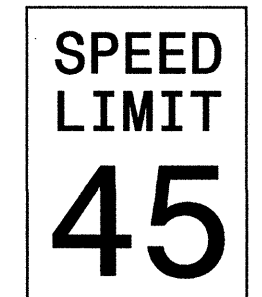

30 X 36  
R2-1

ONE "U" POST PER SIGN

412 QUANTITY REQ'D   2  

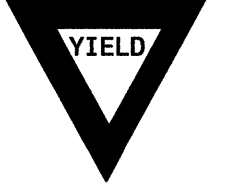

36 X 36 X 36  
R1-2

ONE "U" POST PER SIGN

420 QUANTITY REQ'D   3  



30 X 18  
W16-7

YELLOW/GREEN REFLECTIVE SHEETING

MOUNT BELOW SIGN 457  
IN 2 INSTALLATIONS

ONE "U" POSTS PER SIGN

453 QUANTITY REQ'D   1  



24 X 30  
R2-5a

ONE "U" POST PER SIGN

464 QUANTITY REQ'D   2  

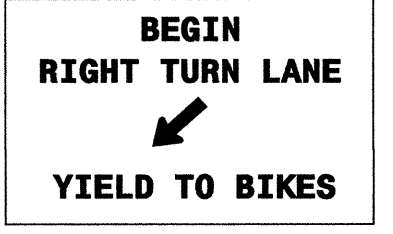

36 X 30  
R4-4

ONE "U" POST PER SIGN

404 QUANTITY REQ'D   4  

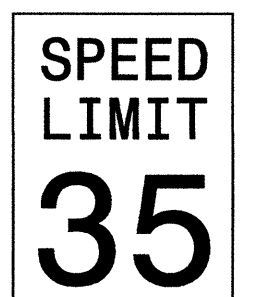

24 X 30  
R2-1

ONE "U" POST PER SIGN

413 QUANTITY REQ'D   2  



54 X 18  
R6-1 (R)

TWO "U" POSTS PER SIGN

421 QUANTITY REQ'D   2  



36 X 36  
S1-1

YELLOW/GREEN REFLECTIVE SHEETING

ONE "U" POSTS PER SIGN

457 QUANTITY REQ'D   3  



30 X 30  
W11-2

YELLOW/GREEN REFLECTIVE SHEETING

ONE "U" POST PER SIGN

465 QUANTITY REQ'D   2  



24 X 12  
W16-9p

MOUNT BELOW SIGN 421  
IN 2 INSTALLATIONS

408 QUANTITY REQ'D   1  



30 X 30  
R1-1

ONE "U" POST PER SIGN

416 QUANTITY REQ'D   1  

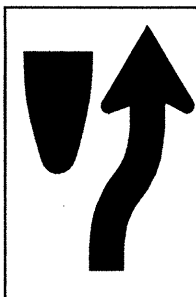

24 X 30  
R4-7

ONE "U" POST PER SIGN

423 QUANTITY REQ'D   1  

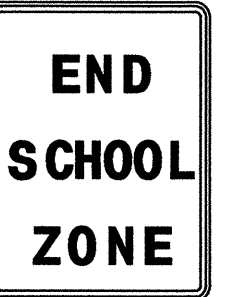

24 X 30  
S5-2

TWO "U" POSTS PER SIGN

461 QUANTITY REQ'D   2  

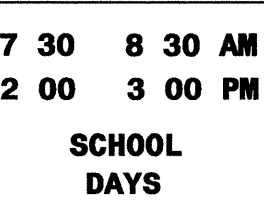

24 X 24  
S4-1a

MOUNT BELOW SIGN 402  
IN 1 INSTALLATIONS

MOUNT BELOW SIGN 453  
IN 1 INSTALLATIONS

410 QUANTITY REQ'D   4  



36 X 24  
R5-1a

ONE "U" POST PER SIGN

417 QUANTITY REQ'D   1  

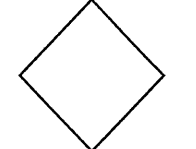

18 X 18  
OM1-3

MOUNT BELOW SIGN 416  
IN 1 INSTALLATIONS

429 QUANTITY REQ'D   1  

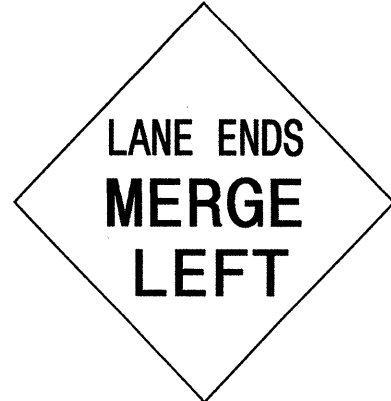

36 X 36  
W9-2(L)

TWO "U" POSTS PER SIGN

462 QUANTITY REQ'D   7  

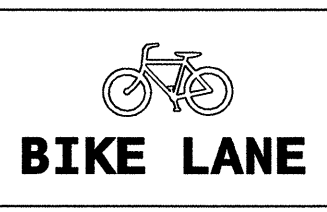

30 X 24  
R3-17

ONE "U" POST PER SIGN

**TYPE "E" SIGNS**

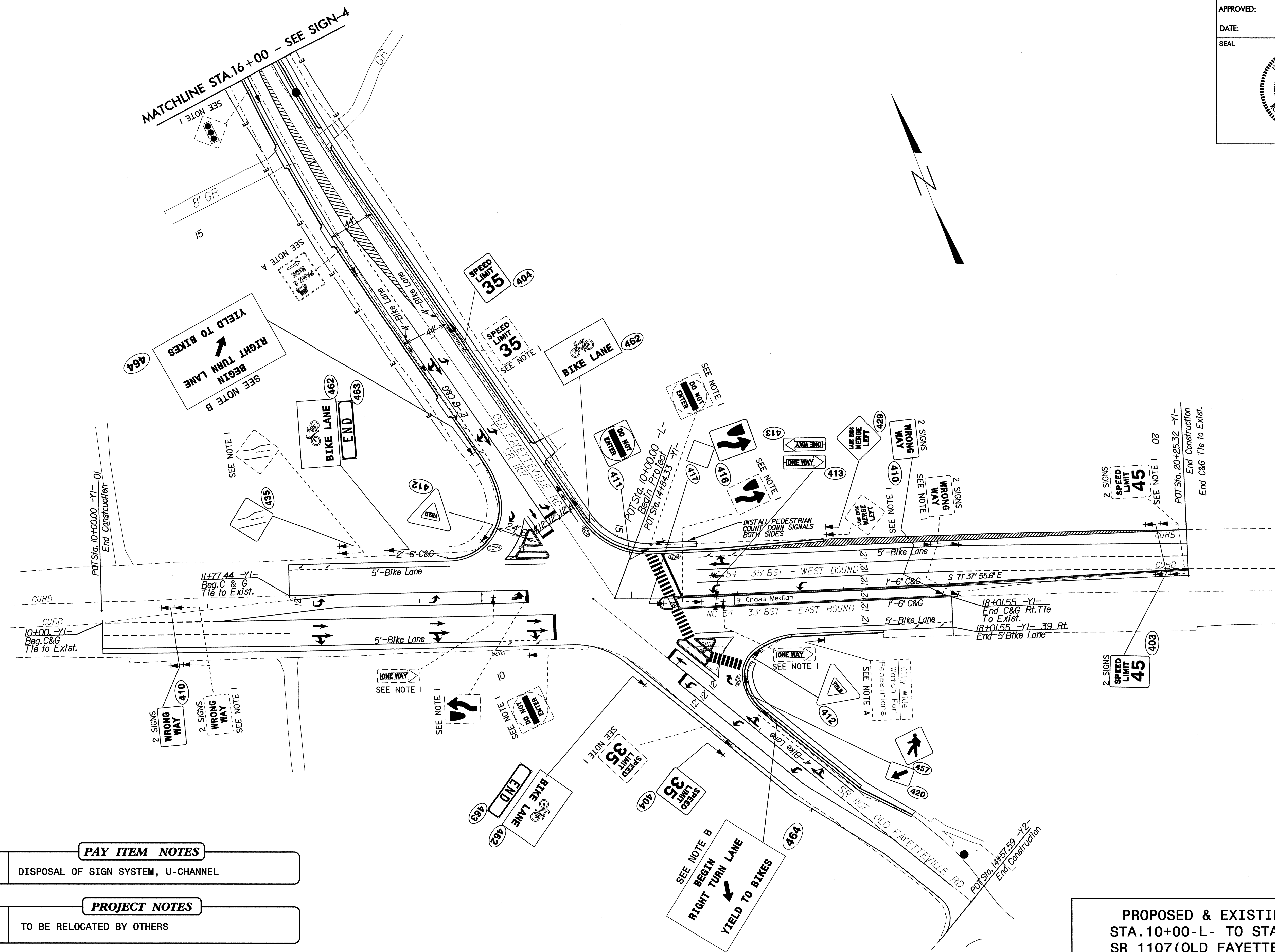
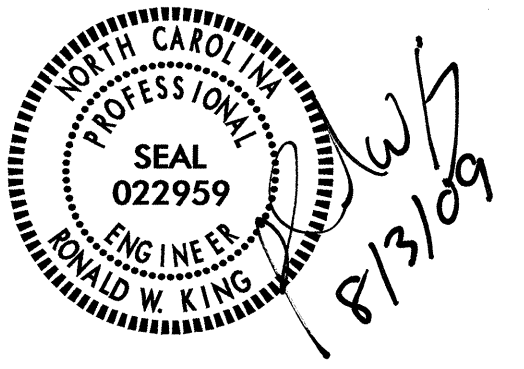

PAY ITEM NOTES	
1	DISPOSAL OF SIGN SYSTEM, U-CHANNEL

PROJECT NOTES	
A	TO BE RELOCATED BY OTHERS

PROPOSED & EXISTING SIGNS  
 STA.10+00-L- TO STA.16+00-L-  
 SR 1107(OLD FAYETTEVILLE RD)

30-JUL-2009 16:44  
 P:\Projects\2009\U-3100B\Traffic\Signing\CADD\Signing\_Layout\Plans\Proj\copy\_all\_U3100B\_S4.dgn  
 s.johns AT TECC221642

TIP NO. U-3100B	SHEET NO. SIGN-4
APPROVED: _____	
DATE: _____	
SEAL	

8/3/09

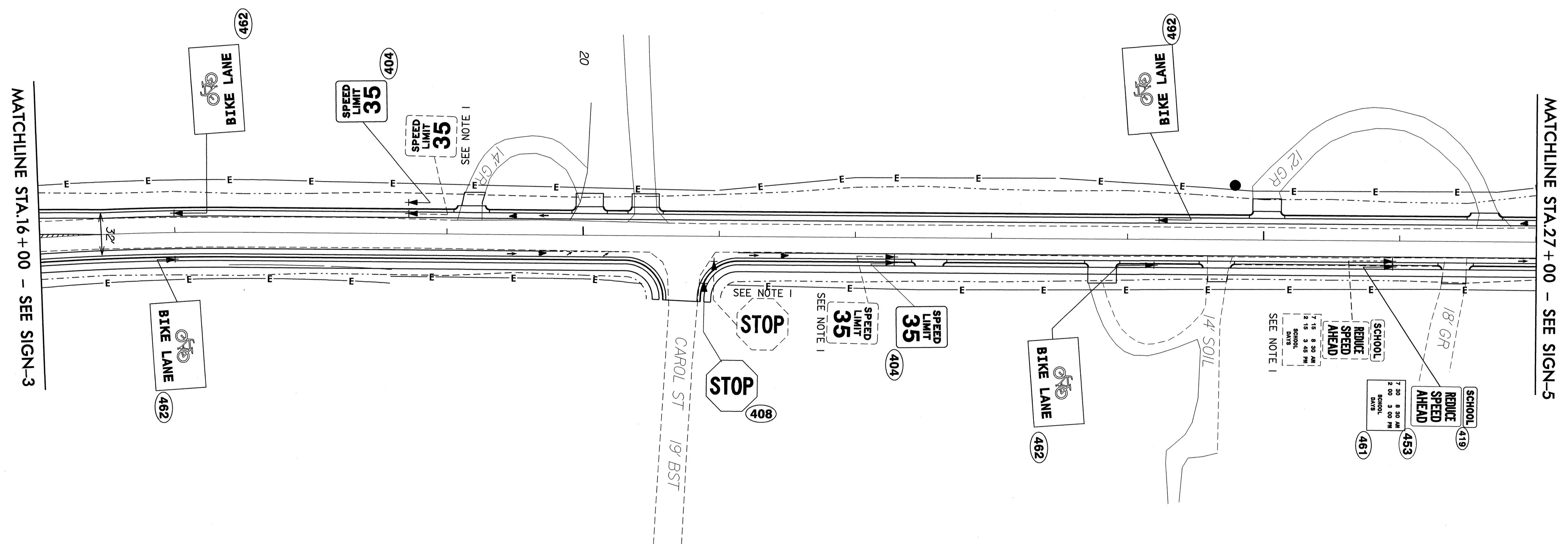
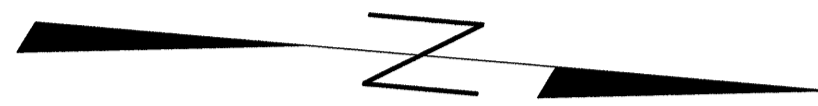

MATCHLINE STA.16+00 - SEE SIGN-3

MATCHLINE STA.27+00 - SEE SIGN-5

PAY ITEM NOTES	
1	DISPOSAL OF SIGN SYSTEM, U-CHANNEL

PROPOSED & EXISTING SIGNS  
 STA.16+00-L- TO STA.27+00-L-  
 SR 1107(OLD FAYETTEVILLE RD)

30-Jul-2009 16:45  
 P:\Projects\2009\1645\1645.dwg  
 s:\johns AT TECC221642

TIP NO. U-3100B	SHEET NO. SIGN-5
APPROVED: _____	
DATE: _____	
SEAL	

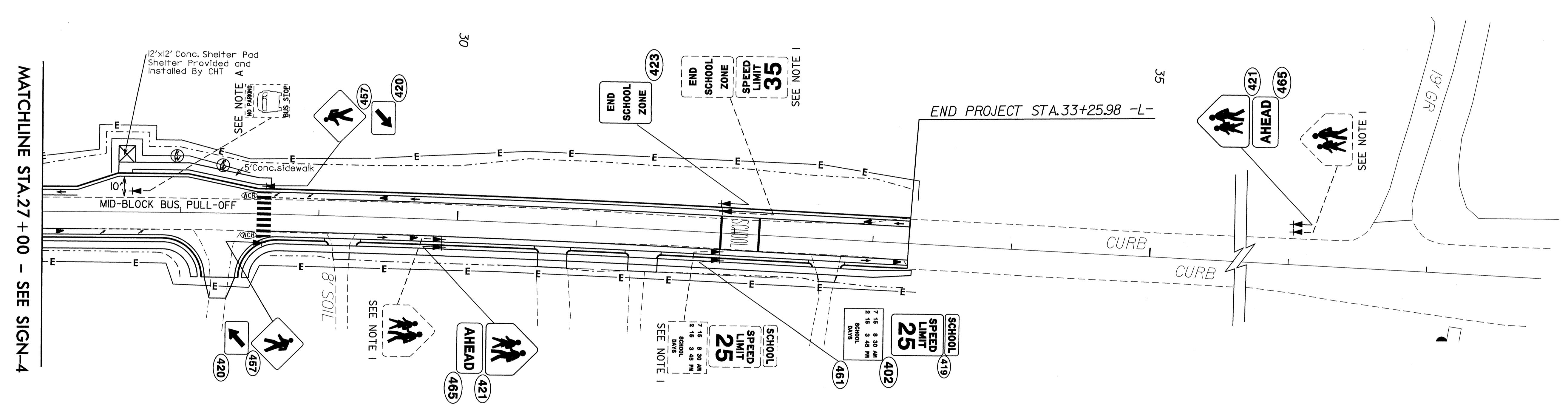
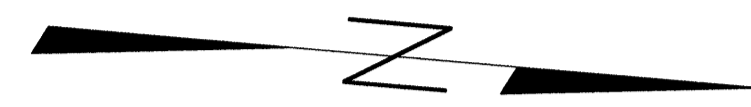

- | PAY ITEM NOTES |                                    |
|----------------|------------------------------------|
| 1              | DISPOSAL OF SIGN SYSTEM, U-CHANNEL |
- 
- | PROJECT NOTES |                           |
|---------------|---------------------------|
| A             | TO BE RELOCATED BY OTHERS |

**PROPOSED & EXISTING SIGNS  
STA.27+00-L- TO STA.33+25.98-L-  
SR 1107(OLD FAYETTEVILLE RD)**

30 JUL 2009 16:45  
 P:\TIP\U-3100B\Traffic\Signing\CADD\Signing Layout Plans\Proj\copy-111-U3100B-S6.dgn  
 R. King  
 AT-TEC221642