

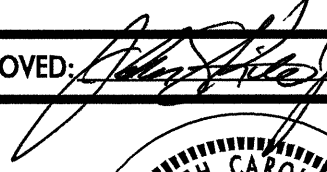

**FINAL PAVEMENT MARKING SCHEDULE**

SYMBOL	DESCRIPTION		PAY ITEM QUANTITY	TOTAL
FINAL PAVEMENT MARKINGS				
T2	WHITE STOPBAR	THERMOPLASTIC(24", 120 MILS)	67 LF	TOTAL 67 LF
TC	10 FT. WHITE SKIP	THERMOPLASTIC(4", 120 MILS)	2520 LF	TOTAL 4502 LF
TD	2 FT. WHITE MINISKIP		228 LF	
TE	WHITE SOLID LANE LINE		1175 LF	
TI	YELLOW DOUBLE CENTER		579 LF	
TA	WHITE EDGELINE	THERMOPLASTIC(4", 90 MILS)	973 LF	TOTAL 1345 LF
TB	YELLOW EDGELINE		372 LF	
TV	WHITE CROSSWALK LINE	THERMOPLASTIC(8", 120 MILS)	53 LF	TOTAL 53 LF
TQ	WHITE DIAGONAL	THERMOPLASTIC(8", 90 MILS)	38 LF	TOTAL 38 LF
THERMOPLASTIC PAVEMENT MARKING SYMBOLS (90 MILS)				
UA	LEFT TURN ARROW		12 EA	TOTAL 27 EA
UB	RIGHT TURN ARROW		7 EA	
UC	STRAIGHT ARROW		8 EA	
MARKERS				
PERMANENT RAISED PAVEMENT MARKERS				
MA	YELLOW & YELLOW		3 EA	TOTAL 1435 EA
MB	CRYSTAL & RED		1432 EA	

23-NOV-2009 14:17  
 \UD01\CAD\ST-0671010246371  
 8mm18r1 AT MZTC246371  
 \tipprojects-u\2810a\traffic\trafficcontrol\top\pmp\_sheets\U-2810A.TC.PMP-01.dgn

APPROVED: 	DATE: 11/23/08	<b>FINAL PAVEMENT MARKING SCHEDULE</b>							
	SCALE: NONE								
	DATE: 06/08								
	DWG. BY: RMG								
	DESIGN BY: RMG								
REVIEWED BY: JDK		<table border="1"> <tr> <th colspan="2">REVISIONS</th> </tr> <tr> <td> </td> <td> </td> </tr> <tr> <td> </td> <td> </td> </tr> </table>		REVISIONS					
REVISIONS									

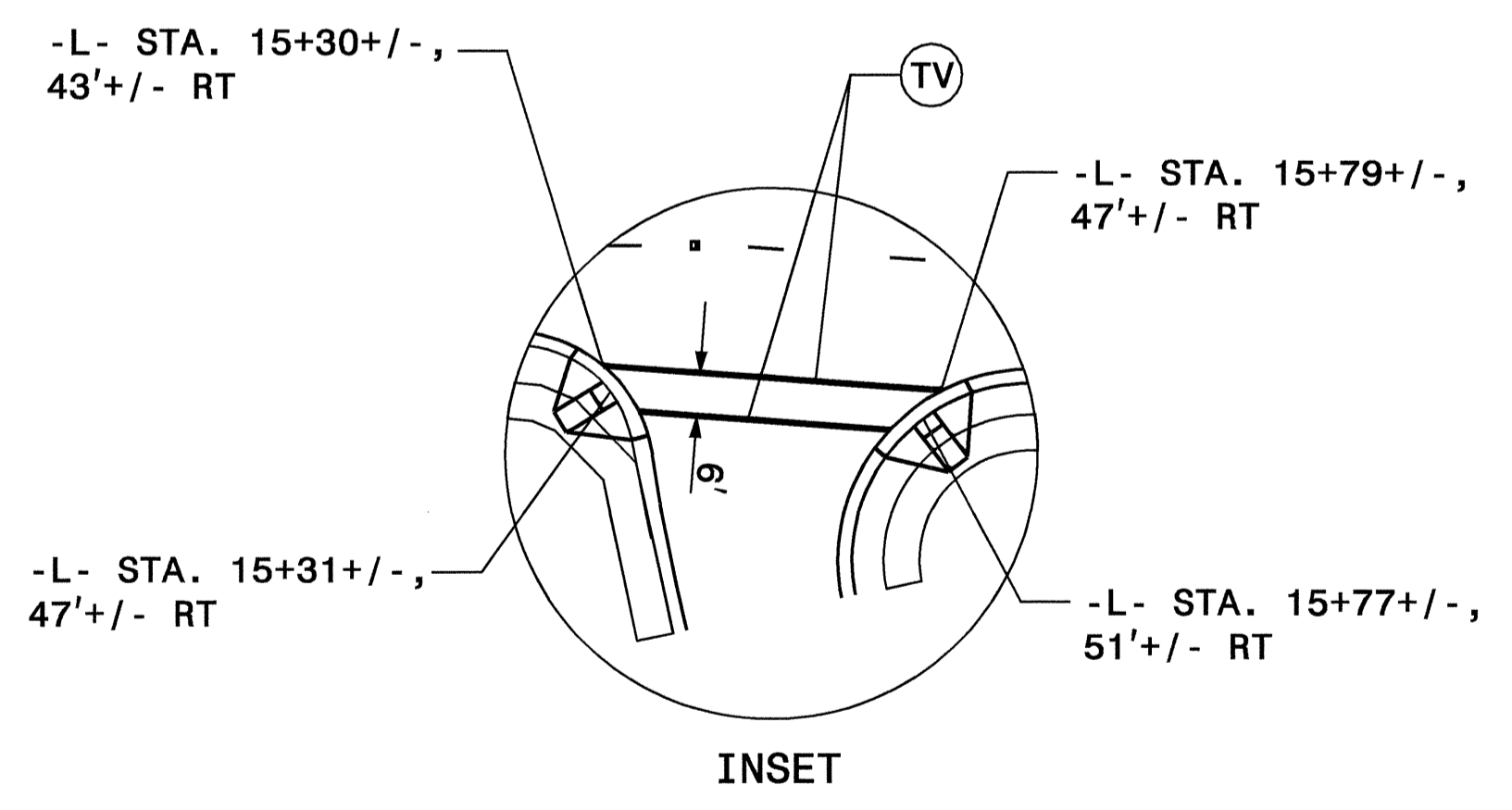
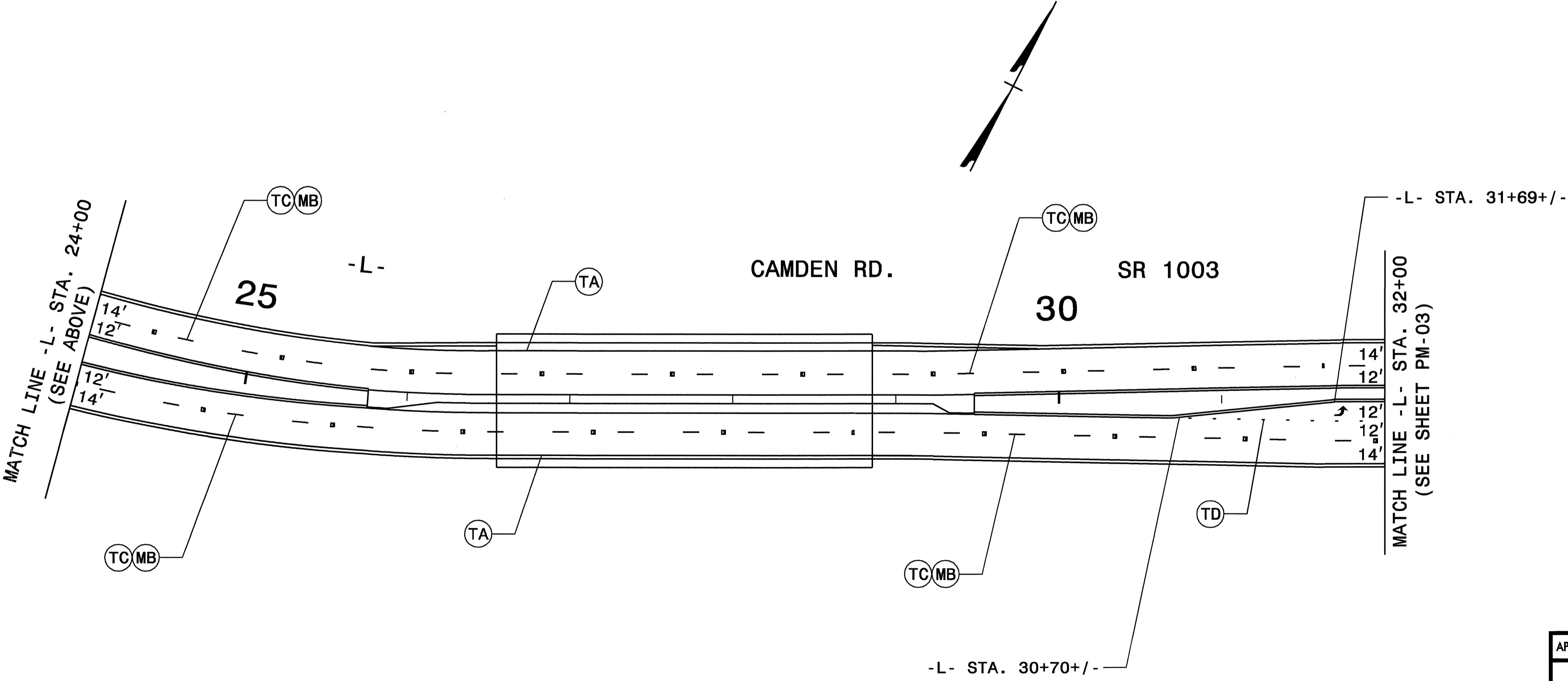
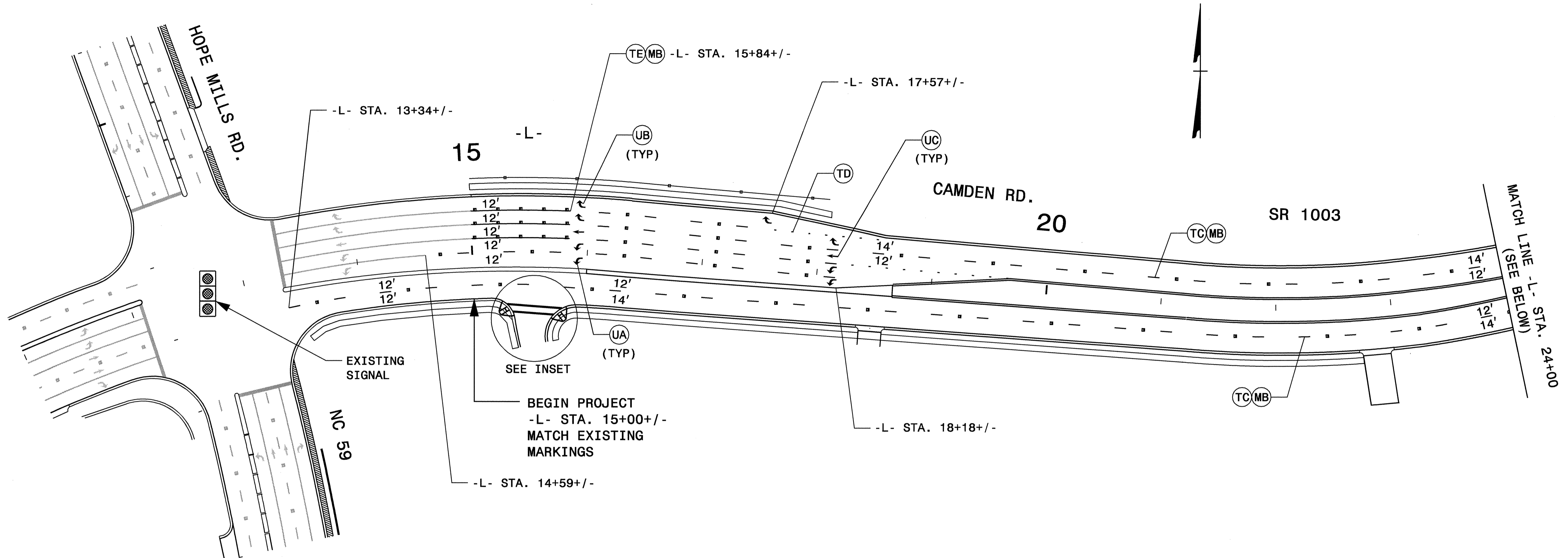

APPROVED: <i>[Signature]</i> DATE: 11/27/07	<b>FINAL PAVEMENT MARKINGS</b>		
	SCALE: NONE		
	DATE: 09/07		REVISIONS
	DWG. BY: RMG		
	DESIGN BY: RMG		
REVIEWED BY: JDK			

23-NOV-2009 14:16  
 U:\DOT\dist\00\DOT\Projects\pmp\projects-u2810a\traffic\control\top\pmp sheets\U-2810A\_TC\_PMP\_02.dgn  
 scmiert1 AT 11/27/07 15:33

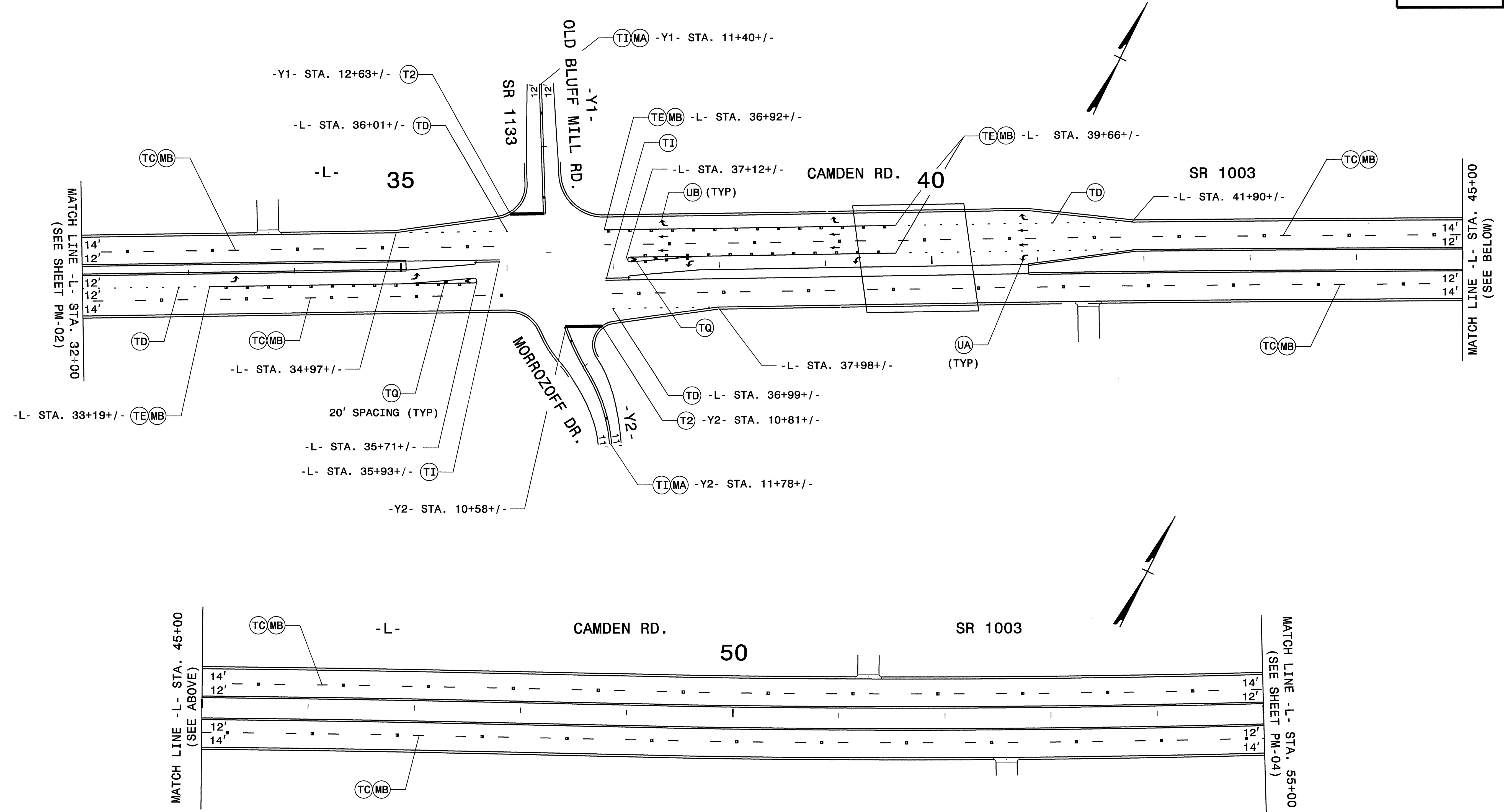

23-NOV-2009 14:16  
 N:\DOT\GIS\07\01\02\03\04\05\06\07\08\09\10\11\12\13\14\15\16\17\18\19\20\21\22\23\24\25\26\27\28\29\30\31\32\33\34\35\36\37\38\39\40\41\42\43\44\45\46\47\48\49\50\51\52\53\54\55\56\57\58\59\60\61\62\63\64\65\66\67\68\69\70\71\72\73\74\75\76\77\78\79\80\81\82\83\84\85\86\87\88\89\90\91\92\93\94\95\96\97\98\99\100\101\102\103\104\105\106\107\108\109\110\111\112\113\114\115\116\117\118\119\120\121\122\123\124\125\126\127\128\129\130\131\132\133\134\135\136\137\138\139\140\141\142\143\144\145\146\147\148\149\150\151\152\153\154\155\156\157\158\159\160\161\162\163\164\165\166\167\168\169\170\171\172\173\174\175\176\177\178\179\180\181\182\183\184\185\186\187\188\189\190\191\192\193\194\195\196\197\198\199\200\201\202\203\204\205\206\207\208\209\210\211\212\213\214\215\216\217\218\219\220\221\222\223\224\225\226\227\228\229\230\231\232\233\234\235\236\237\238\239\240\241\242\243\244\245\246\247\248\249\250\251\252\253\254\255\256\257\258\259\260\261\262\263\264\265\266\267\268\269\270\271\272\273\274\275\276\277\278\279\280\281\282\283\284\285\286\287\288\289\290\291\292\293\294\295\296\297\298\299\300\301\302\303\304\305\306\307\308\309\310\311\312\313\314\315\316\317\318\319\320\321\322\323\324\325\326\327\328\329\330\331\332\333\334\335\336\337\338\339\340\341\342\343\344\345\346\347\348\349\350\351\352\353\354\355\356\357\358\359\360\361\362\363\364\365\366\367\368\369\370\371\372\373\374\375\376\377\378\379\380\381\382\383\384\385\386\387\388\389\390\391\392\393\394\395\396\397\398\399\400\401\402\403\404\405\406\407\408\409\410\411\412\413\414\415\416\417\418\419\420\421\422\423\424\425\426\427\428\429\430\431\432\433\434\435\436\437\438\439\440\441\442\443\444\445\446\447\448\449\450\451\452\453\454\455\456\457\458\459\460\461\462\463\464\465\466\467\468\469\470\471\472\473\474\475\476\477\478\479\480\481\482\483\484\485\486\487\488\489\490\491\492\493\494\495\496\497\498\499\500\501\502\503\504\505\506\507\508\509\510\511\512\513\514\515\516\517\518\519\520\521\522\523\524\525\526\527\528\529\530\531\532\533\534\535\536\537\538\539\540\541\542\543\544\545\546\547\548\549\550\551\552\553\554\555\556\557\558\559\560\561\562\563\564\565\566\567\568\569\570\571\572\573\574\575\576\577\578\579\580\581\582\583\584\585\586\587\588\589\590\591\592\593\594\595\596\597\598\599\600\601\602\603\604\605\606\607\608\609\610\611\612\613\614\615\616\617\618\619\620\621\622\623\624\625\626\627\628\629\630\631\632\633\634\635\636\637\638\639\640\641\642\643\644\645\646\647\648\649\650\651\652\653\654\655\656\657\658\659\660\661\662\663\664\665\666\667\668\669\670\671\672\673\674\675\676\677\678\679\680\681\682\683\684\685\686\687\688\689\690\691\692\693\694\695\696\697\698\699\700\701\702\703\704\705\706\707\708\709\710\711\712\713\714\715\716\717\718\719\720\721\722\723\724\725\726\727\728\729\730\731\732\733\734\735\736\737\738\739\740\741\742\743\744\745\746\747\748\749\750\751\752\753\754\755\756\757\758\759\760\761\762\763\764\765\766\767\768\769\770\771\772\773\774\775\776\777\778\779\780\781\782\783\784\785\786\787\788\789\790\791\792\793\794\795\796\797\798\799\800\801\802\803\804\805\806\807\808\809\810\811\812\813\814\815\816\817\818\819\820\821\822\823\824\825\826\827\828\829\830\831\832\833\834\835\836\837\838\839\840\841\842\843\844\845\846\847\848\849\850\851\852\853\854\855\856\857\858\859\860\861\862\863\864\865\866\867\868\869\870\871\872\873\874\875\876\877\878\879\880\881\882\883\884\885\886\887\888\889\890\891\892\893\894\895\896\897\898\899\900\901\902\903\904\905\906\907\908\909\910\911\912\913\914\915\916\917\918\919\920\921\922\923\924\925\926\927\928\929\930\931\932\933\934\935\936\937\938\939\940\941\942\943\944\945\946\947\948\949\950\951\952\953\954\955\956\957\958\959\960\961\962\963\964\965\966\967\968\969\970\971\972\973\974\975\976\977\978\979\980\981\982\983\984\985\986\987\988\989\990\991\992\993\994\995\996\997\998\999\1000

APPROVED: [Signature] DATE: 11/23/07

SEAL

**FINAL PAVEMENT MARKINGS**

SCALE: NONE  
 DATE: 09/07  
 DWG. BY: RMG  
 DESIGN BY: RMG  
 REVIEWED BY: JDK

REVISIONS	

CADD FILE

PROJ. REFERENCE NO.	SHEET NO.
U-2810A	PM-4

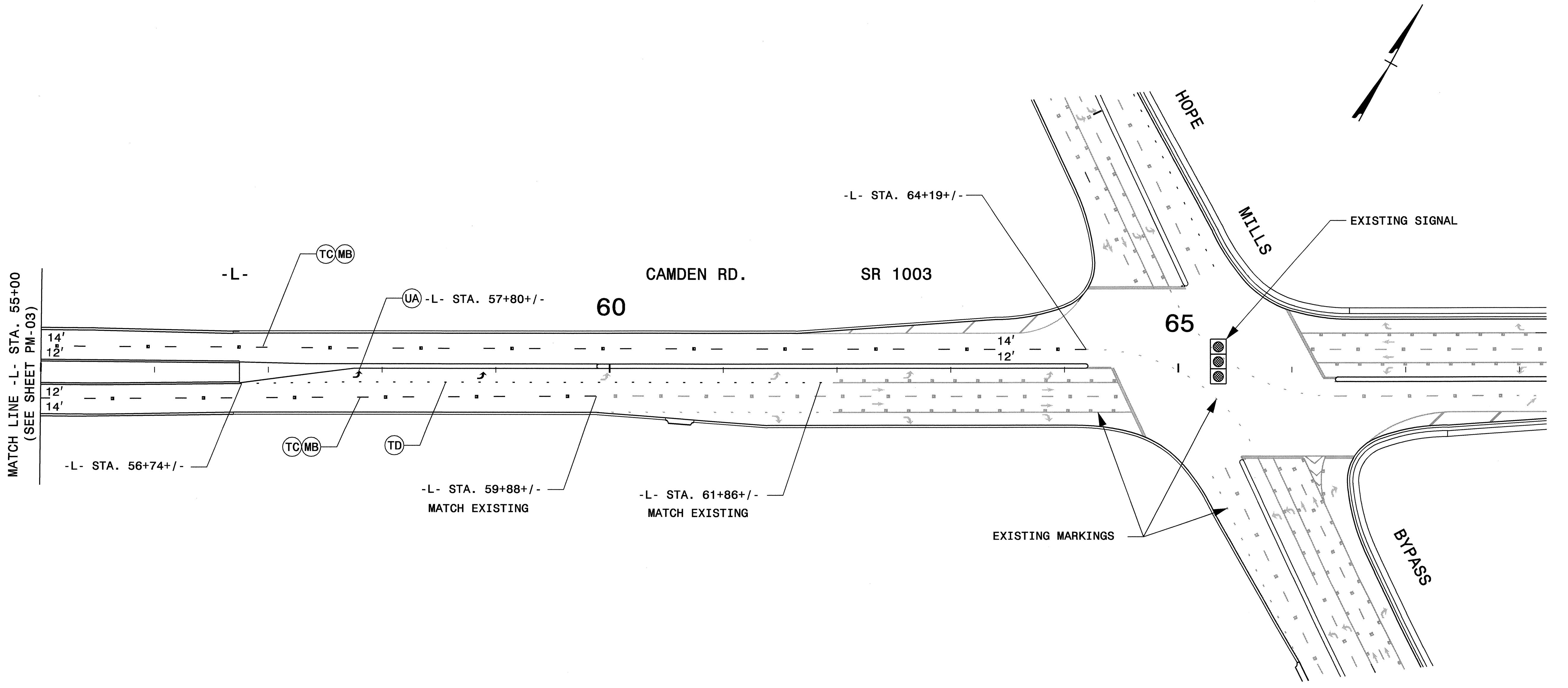

MATCH LINE -L- STA. 55+00  
(SEE SHEET PM-03)

-L- (TC/MB)

UA -L- STA. 57+80 +/-

60

-L- STA. 64+19 +/-

CAMDEN RD.

SR 1003

65

EXISTING SIGNAL

14'

12'

14'

12'

-L- STA. 56+74 +/-

(TC/MB)

(TD)

-L- STA. 59+88 +/-  
MATCH EXISTING

-L- STA. 61+86 +/-  
MATCH EXISTING

EXISTING MARKINGS

BYPASS

23-NOV-2009 14:15 \\ADON\gfs06\071022463\11\ipproj\subjects-u\2810a\traff\tr\afficcontrol\top\pmp\_sheets\U-2810A\_TC.PMP\_04.dgn

APPROVED: [Signature] DATE: 11/23/07

SEAL

FINAL PAVEMENT MARKINGS

SCALE: NONE  
DATE: 09/07  
DWG. BY: RMG  
DESIGN BY: RMG  
REVIEWED BY: JDK

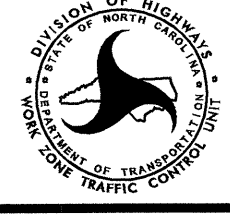

NO.	DATE	REVISIONS

CADD FILE