

FINAL PAVEMENT MARKING SCHEDULE

SYMBOL	DESCRIPTION
FINAL PAVEMENT MARKINGS	
PAINT(4")	
PA	WHITE EDGELINE (2X)
PB	YELLOW EDGELINE (2X)
PC	10 FT. WHITE SKIP (2X)
PD	2 FT. WHITE MINISKIP (2X)
THERMOPLASTIC (4") Standard Glass Beads	
TA	WHITE EDGELINE
TB	YELLOW EDGELINE
TC	10 FT. WHITE SKIP
TD	2 FT. WHITE MINISKIP
TE	WHITE SOLID LANE LINE
TF	10 FT. YELLOW SKIP
TH	YELLOW SINGLE CENTER
TI	YELLOW DOUBLE CENTER
THERMOPLASTIC (8") Standard Glass Beads	
TP	WHITE GORELINE
TQ	WHITE DIAGONAL
TT	YELLOW DIAGONAL
THERMOPLASTIC (24") Standard Glass Beads	
T2	WHITE STOPBAR
THERMOPLASTIC PAVEMENT MARKING CHARACTER Standard Glass Beads	
UI	ALPHANUMERIC
THERMOPLASTIC PAVEMENT MARKING SYMBOL Standard Glass Beads	
UA	LEFT TURN ARROW
UB	RIGHT TURN ARROW
UC	STRAIGHT ARROW
UD	COMBO STRAIGHT/LEFT
UE	COMBO STRAIGHT/RIGHT
UG	COMBO LEFT/RIGHT/STRAIGHT

I2-AUG-2009 08:30
 \dot\vd\st\cort\01\NSP\proj\1\ipproj\jects-r\2417c\tr\affic\tr\of\fic\cont\tr\top\pmp\R-2417C-TC-TCP_PMP_01.dgn
 dmsyes AT WZ12244138

APPROVED: <i>J.W. Woolard</i>	DATE: 8/17/09	FINAL PAVEMENT MARKING SCHEDULE	
SEAL 	SCALE: NONE		REVISIONS
	DATE: 08/09		
	DWG. BY: DAH		
	DESIGN BY: DAH		
REVIEWED BY: JWW			

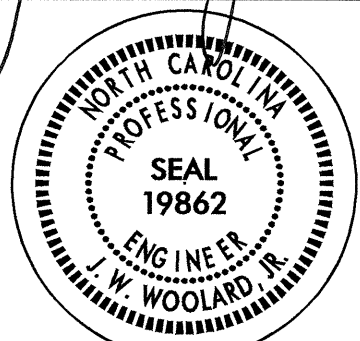
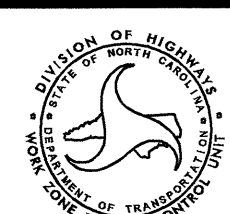
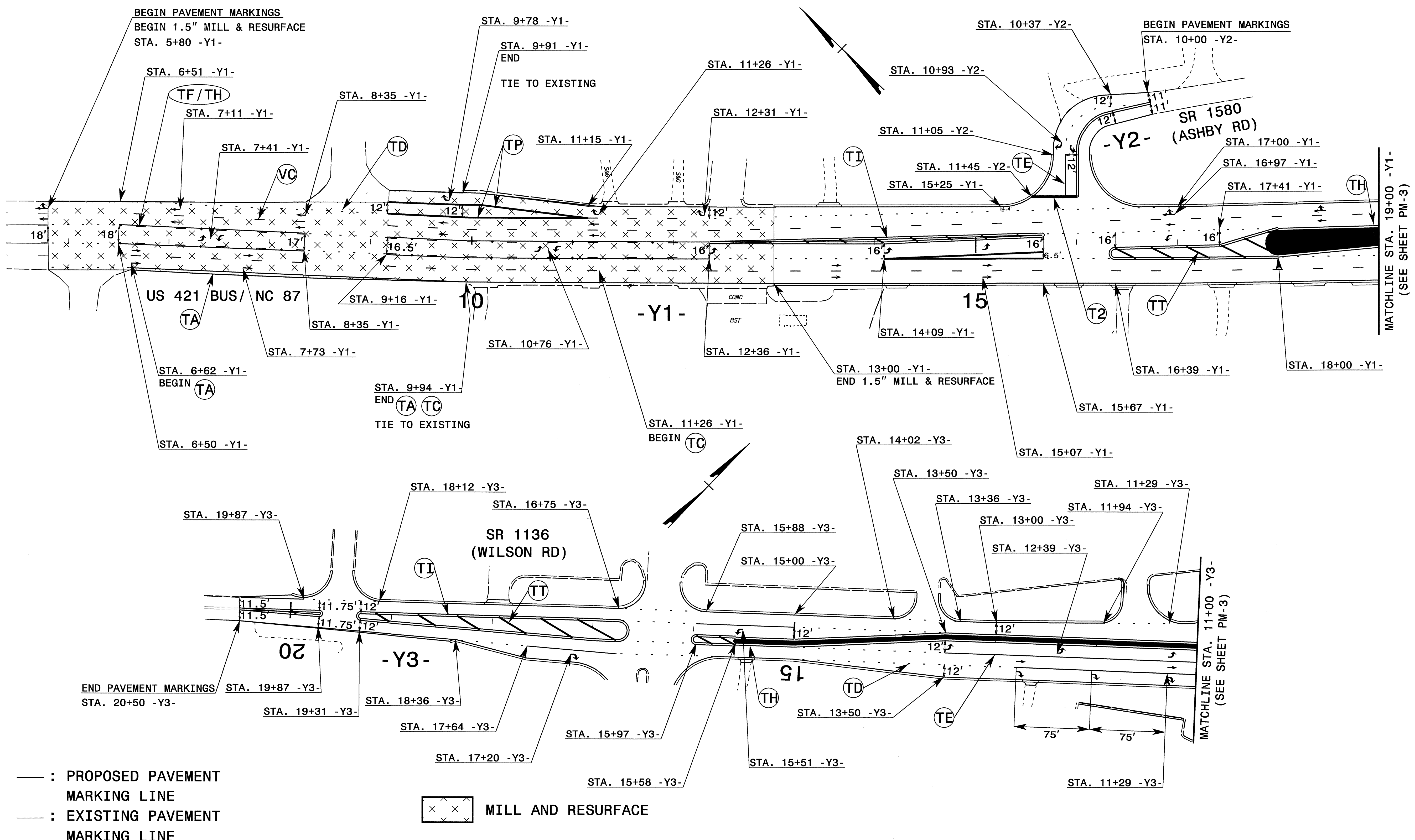

- : PROPOSED PAVEMENT MARKING LINE
- - : EXISTING PAVEMENT MARKING LINE
- ↙ : UA ↖ : UD ↗ : UG
- ↘ : UB ↙ : UE
- ↕ : UC ↘ : UF
- : EXISTING PAVEMENT MARKING SYMBOL

 MILL AND RESURFACE

NOTE: ALL LANE DIMENSIONS ARE 12' UNLESS NOTED ON PLAN SHEETS.
NOTE: ALL SYMBOLS ARE 150' FROM SYMBOL TO SYMBOL UNLESS NOTED ON PLAN SHEETS.

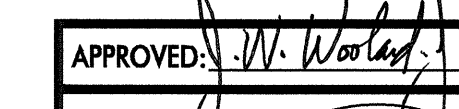
APPROVED:  DATE: 9/21/09

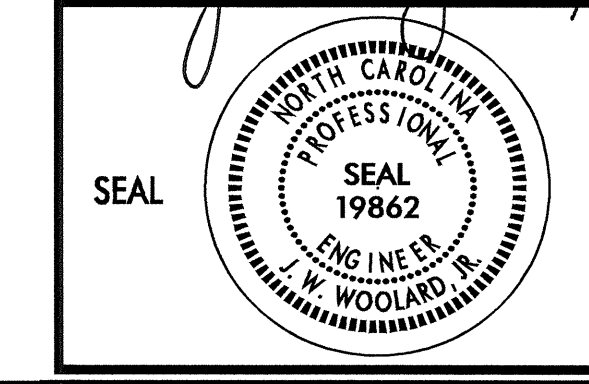

FINAL PAVEMENT MARKING PLAN

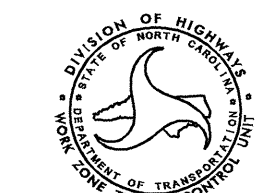
SCALE: NONE		REVISIONS
DATE: 08/09		
DWG. BY: DAH		
DESIGN BY: DAH		
REVIEWED BY: JWW		

01-SEP-2009 14:55
V:\Projects\2417C\Traffic\TrafficControl\top\pmp\2417c_fc_top_pmp_02.dgn
AT: WJL241738

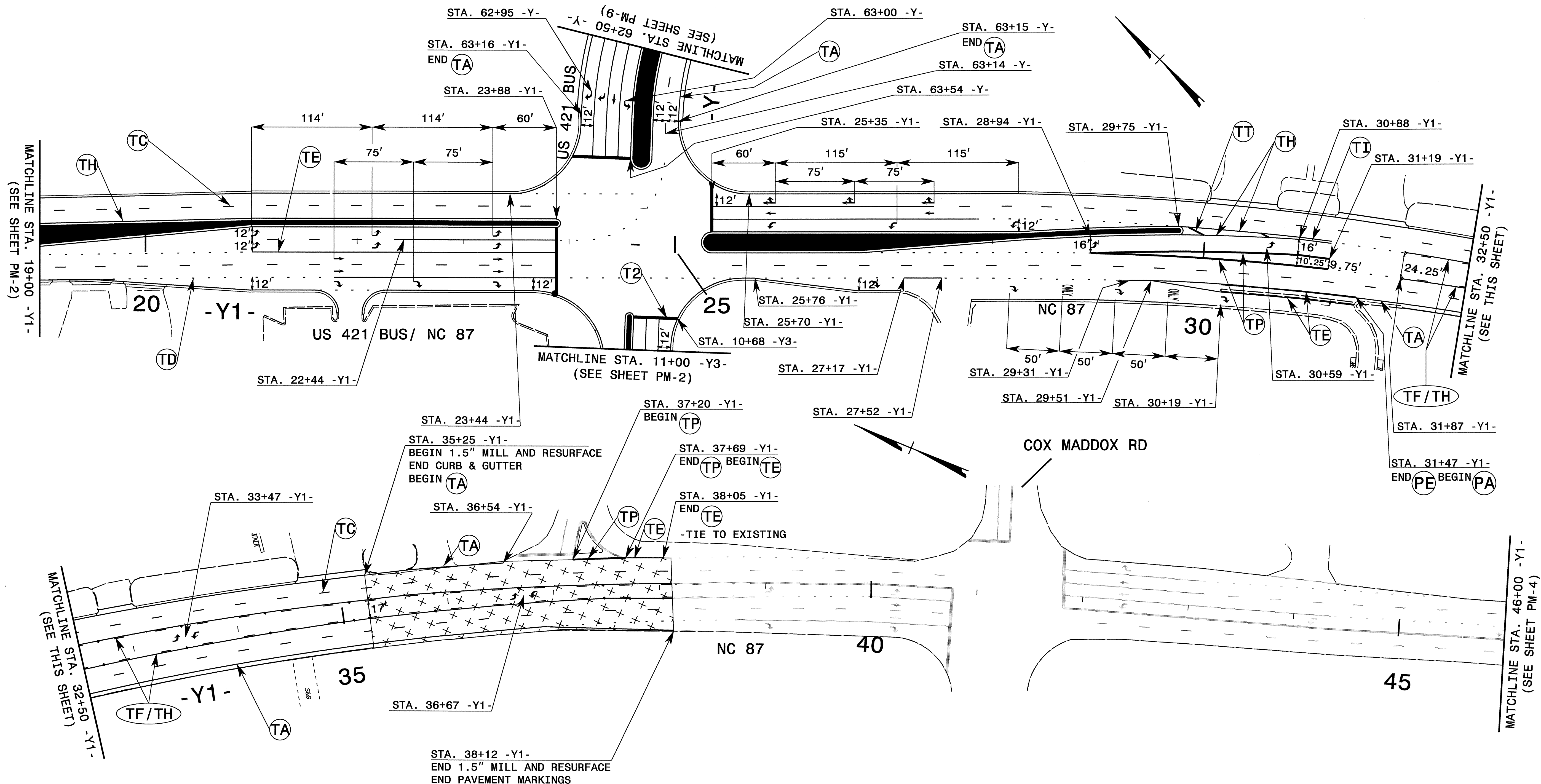

- : PROPOSED PAVEMENT MARKING LINE
- - - : EXISTING PAVEMENT MARKING LINE
- ↔ : UA ↗ : UD ↘ : UG
- ↖ : UB ↙ : UE
- : UC ↕ : UF
- ↪ : EXISTING PAVEMENT MARKING SYMBOL

NOTE: ALL LANE DIMENSIONS ARE 12' UNLESS NOTED ON PLAN SHEETS.

✕ ✕ ✕ ✕ MILL AND RESURFACE

APPROVED: *[Signature]* DATE: 9/01/09
 SEAL
 NORTH CAROLINA PROFESSIONAL ENGINEER
 19862
 W. WOOLARD

FINAL PAVEMENT MARKING PLAN	
SCALE: NONE	REVISIONS
DATE: 08/09	
DWG. BY: DAH	
DESIGN BY: DAH	
REVIEWED BY: JWW	

01-SEP-2009 14:55
 \\dot\dfsroot\NSP\proj\traffic\tr\trafficcontrol\top\mp\p-r-2417c-traffic\tr\trafficcontrol\top\mp\p-r-2417c-tp-mp-03.dgn
 ahayes AT WZ1C244738

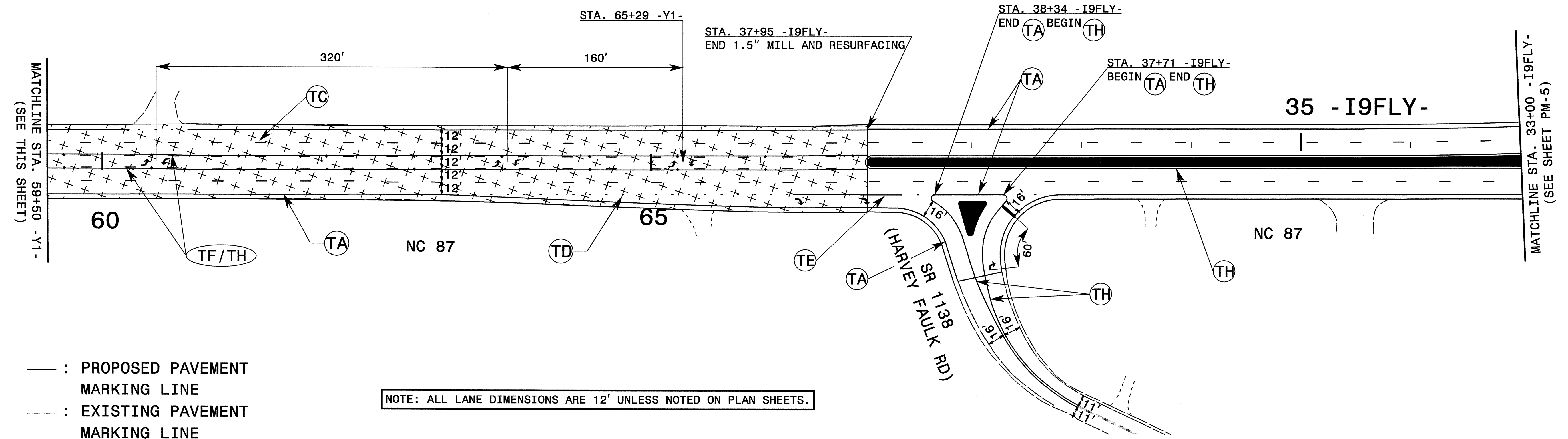
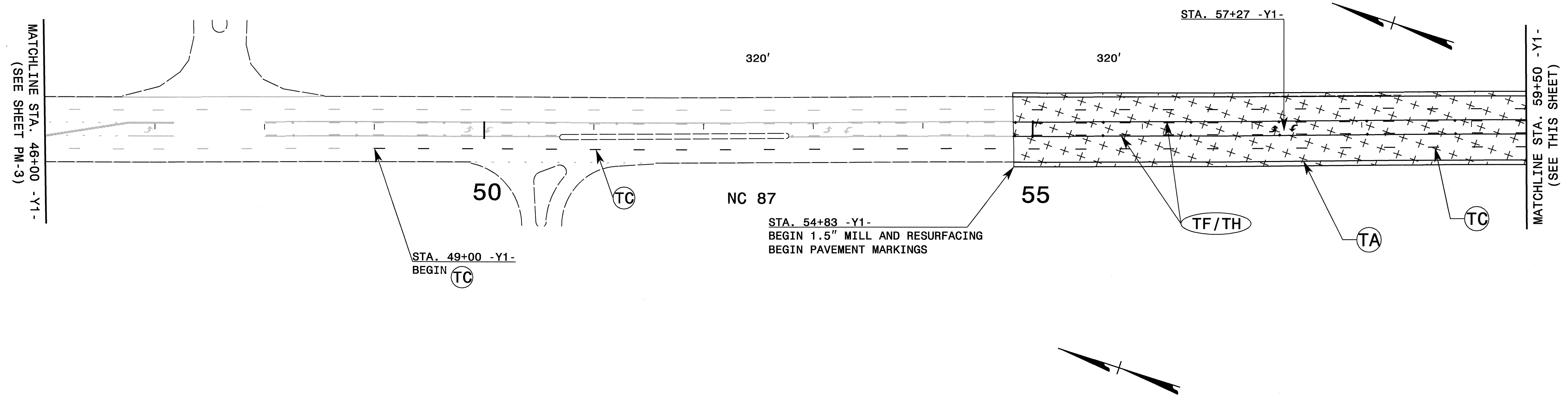

- : PROPOSED PAVEMENT MARKING LINE
- - - : EXISTING PAVEMENT MARKING LINE
- ↔ : UA ↔ : UD ↔ : UG
- ↔ : UB ↔ : UE
- ↔ : UC ↔ : UF
- ↔ : EXISTING PAVEMENT MARKING SYMBOL

NOTE: ALL LANE DIMENSIONS ARE 12' UNLESS NOTED ON PLAN SHEETS.

MILL AND RESURFACE

APPROVED: <i>W. Woolard</i> DATE: 9/01/09	FINAL PAVEMENT MARKING PLAN	
SCALE: NONE		REVISIONS
DATE: 08/09		
DWG. BY: DAH		
DESIGN BY: DAH		
REVIEWED BY: JWW		CADD FILE

01-SEP-2009 14:54
 \\D:\1\dfs\00\01\NSP\01\ip\projects-r\2417c\traffic\traffic\top\pmp-r-2417c-tc-top.pmp_04.dgn
 ahayes AT W 12/24/08

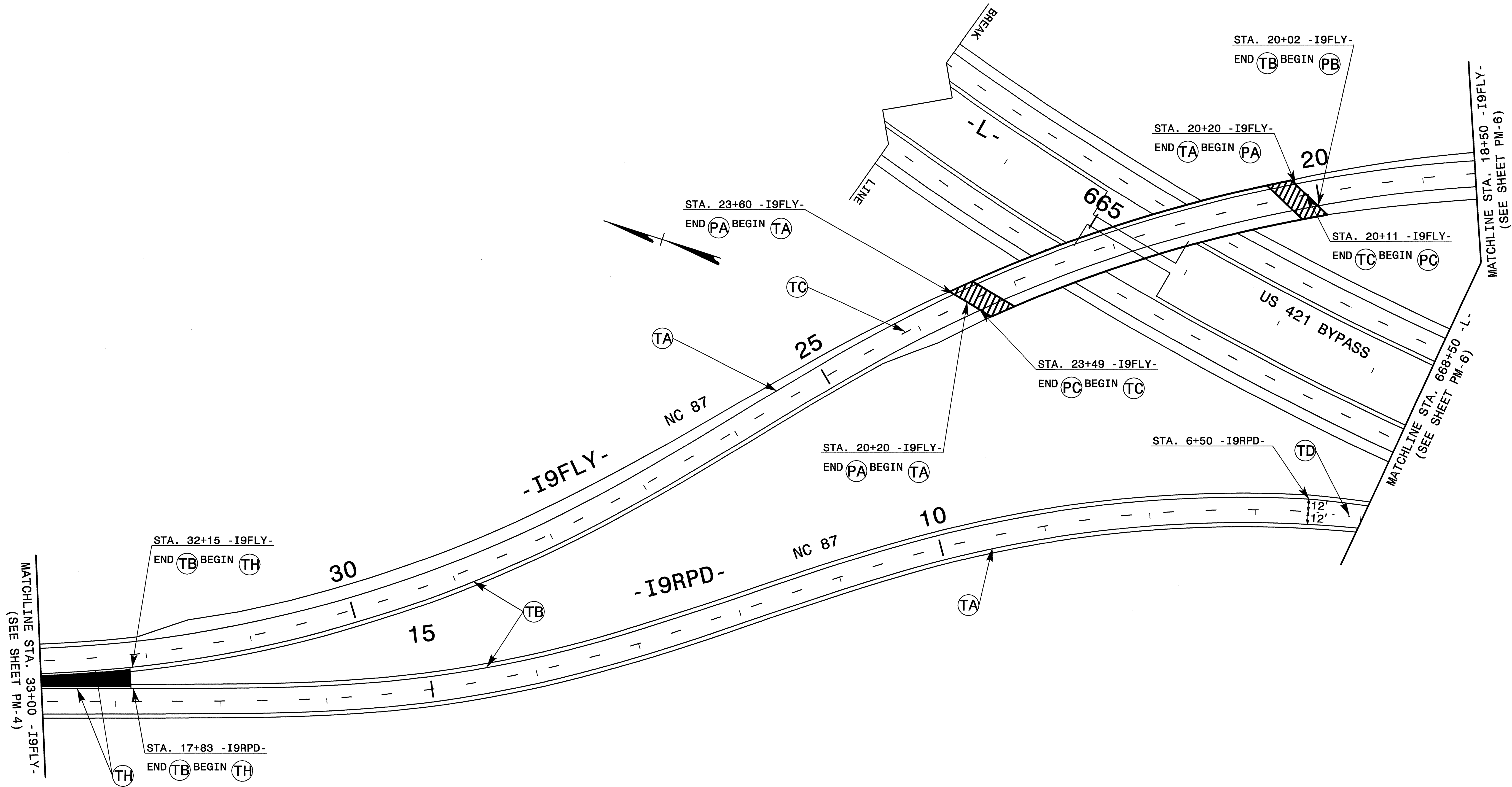

- : PROPOSED PAVEMENT MARKING LINE
- - - : EXISTING PAVEMENT MARKING LINE
- ↪ : UA ↻ : UD ↻ : UG
- ↪ : UB ↻ : UE
- ↪ : UC ↻ : UF
- ↪ : EXISTING PAVEMENT MARKING SYMBOL

NOTE: ALL LANE DIMENSIONS ARE 12' UNLESS NOTED ON PLAN SHEETS.

APPROVED: <i>J.W. Woolard</i> DATE: 8/2/09	FINAL PAVEMENT MARKING PLAN							
SCALE: NONE	DATE: 08/09	<table border="1"> <tr> <th colspan="2">REVISIONS</th> </tr> <tr> <td> </td> <td> </td> </tr> <tr> <td> </td> <td> </td> </tr> </table>	REVISIONS					
REVISIONS								
DWG. BY: DAH	DESIGN BY: DAH							
REVIEWED BY: JWW		<small>CADD FILE</small>						

12-AUG-2009 08:28
 \\dot\dfs\go\NTP\projects-r\2417c\traffic\trafficcontrol\top\PMR-R-2417C-TC.TCP_PMP_05.dgn
 dnyes AT WZTC244738

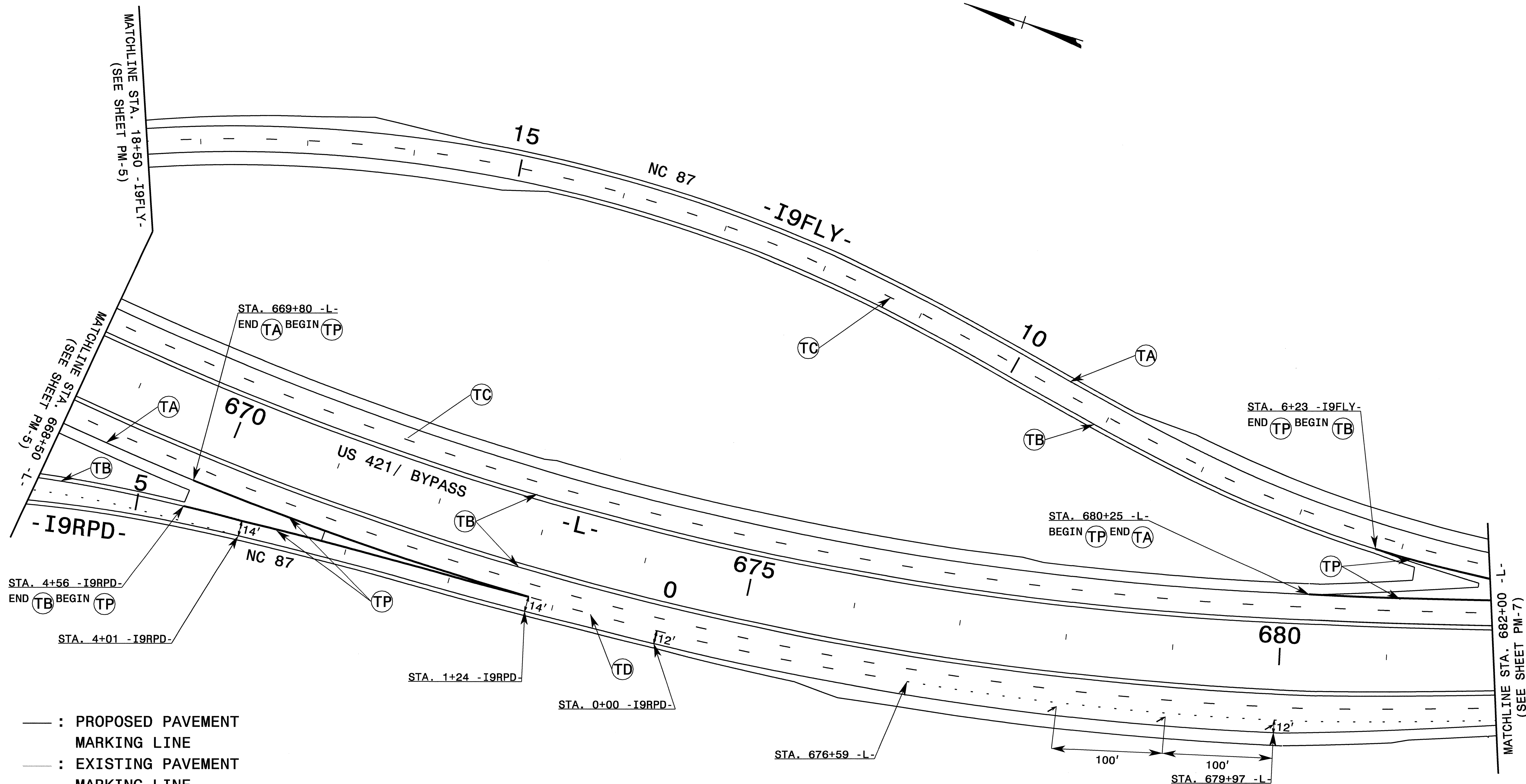

- : PROPOSED PAVEMENT MARKING LINE
- : EXISTING PAVEMENT MARKING LINE
- : UA : UD : UG
- : UB : UE
- : UC : UF
- : EXISTING PAVEMENT MARKING SYMBOL

NOTE: ALL LANE DIMENSIONS ARE 12' UNLESS NOTED ON PLAN SHEETS.

APPROVED: DATE: 8/12/09

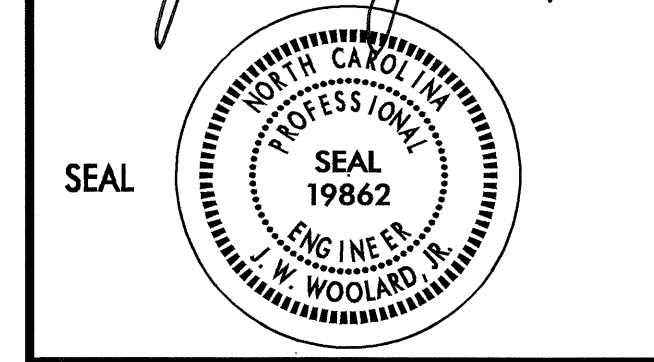

FINAL PAVEMENT MARKING PLAN

SCALE: NONE
DATE: 08/09
DWG. BY: DAH
DESIGN BY: DAH
REVIEWED BY: JWW

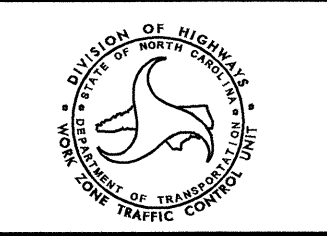

REVISIONS

12-AUG-2009 09:28 \\dot\dfs\go\0\1\NSP\0\1\proj\projects-r\2417c\Traffic\Traffic\control\top\PM\PM-R-2417C-TC-TP_PMP_06.dgn

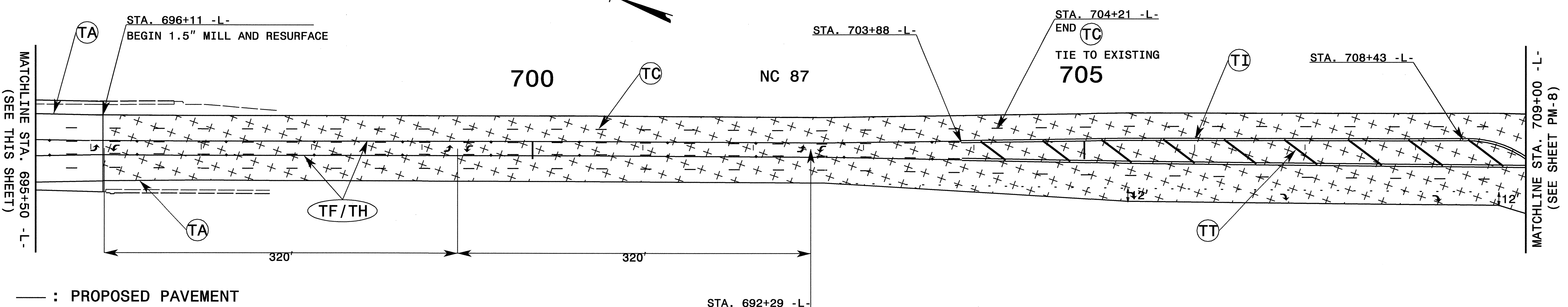
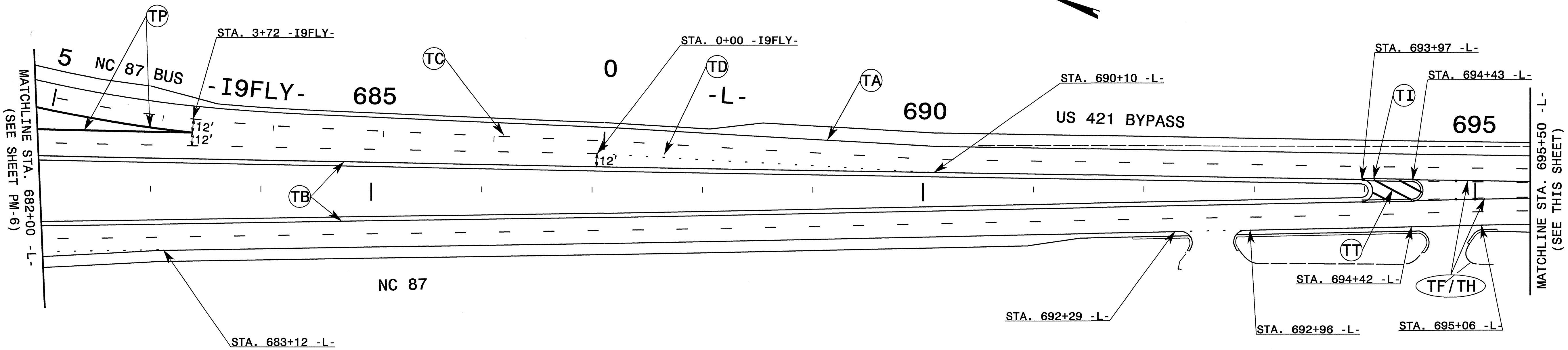

- : PROPOSED PAVEMENT MARKING LINE
- - - : EXISTING PAVEMENT MARKING LINE
- ↔ : UA ↕ : UD ↔ : UG
- ↔ : UB ↕ : UE
- ↔ : UC ↕ : UF
- ↔ : EXISTING PAVEMENT MARKING SYMBOL

NOTE: ALL LANE DIMENSIONS ARE 12' UNLESS NOTED ON PLAN SHEETS.

MILL AND RESURFACE

APPROVED:	DATE: 9/01/09	FINAL PAVEMENT MARKING PLAN							
SCALE: NONE									
DATE: 08/09									
DWG. BY: DAH									
REVIEWED BY: JWW									
		REVISIONS							
		<table border="1"> <tr> <td> </td> <td> </td> </tr> <tr> <td> </td> <td> </td> </tr> <tr> <td> </td> <td> </td> </tr> </table>							

01-SEP-2009 14:54
 \\dot\dfsroot\NSP\proj\pmp\proj\traffico\traffico\pmp\pmp\2417c\fc_tc_top_pmp_07.dgn
 ahayes AT WZTC244738

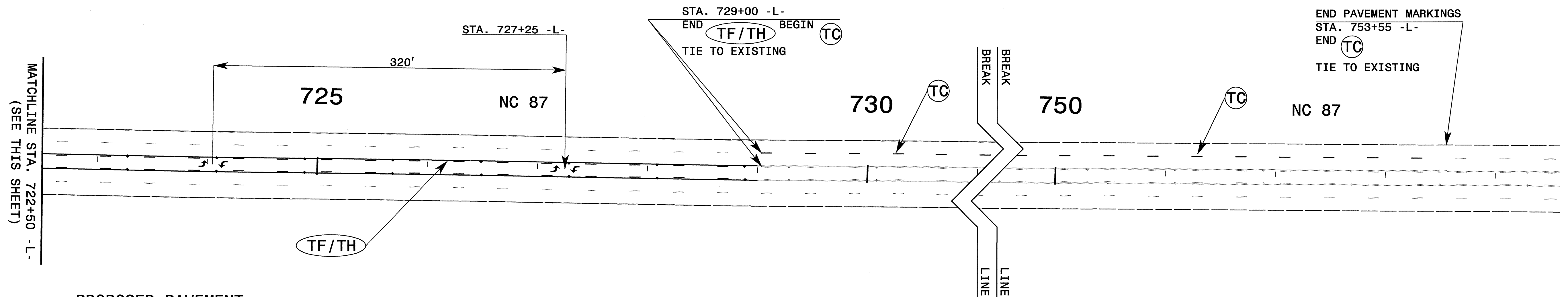
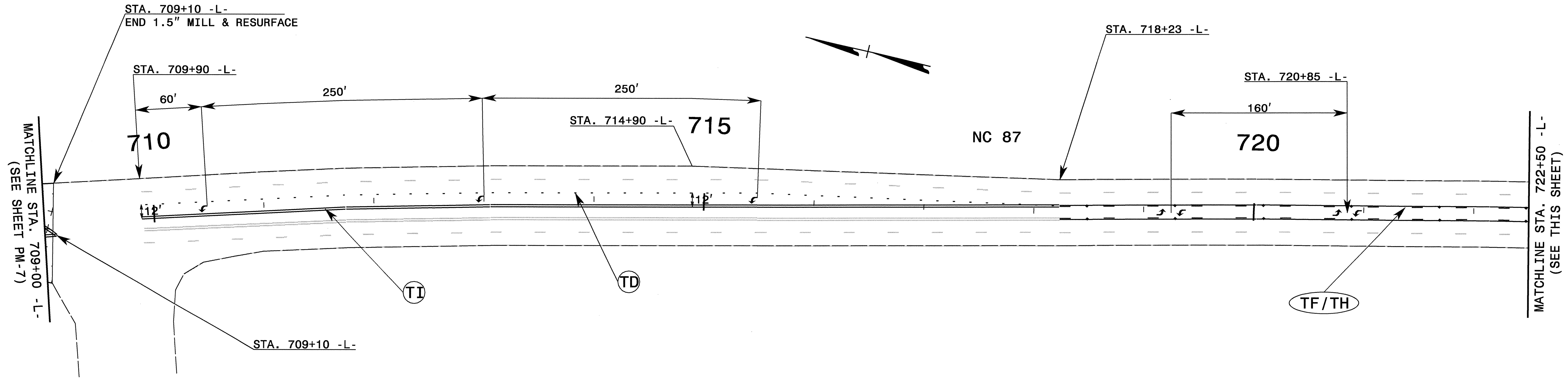

- : PROPOSED PAVEMENT MARKING LINE
- - - : EXISTING PAVEMENT MARKING LINE
- ↔ : UA ↔ : UD ↔ : UG
- ↔ : UB ↔ : UE
- ↔ : UC ↔ : UF
- ↔ : EXISTING PAVEMENT MARKING SYMBOL

NOTE: ALL LANE DIMENSIONS ARE 12' UNLESS NOTED ON PLAN SHEETS.

 MILL AND RESURFACE

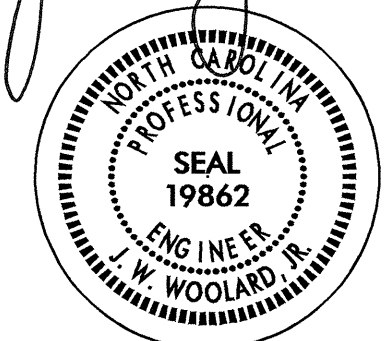
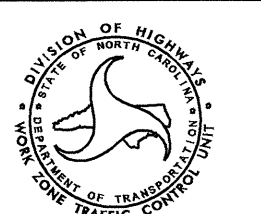
APPROVED: 	DATE: 9/10/09	FINAL PAVEMENT MARKING PLAN	
			
SCALE: NONE	DATE: 08/09		
DWG. BY: DAH	DESIGN BY: DAH		
REVIEWED BY: JWW			

01-SEP-2009 14:53
 \\dot\dfsroot\01\NSP\proj\1\pmp\traffic\tr\officecontrol\top\pmp\R-2417c_fc_tcp_pmp_08.dgn
 dhayes AT W21244738

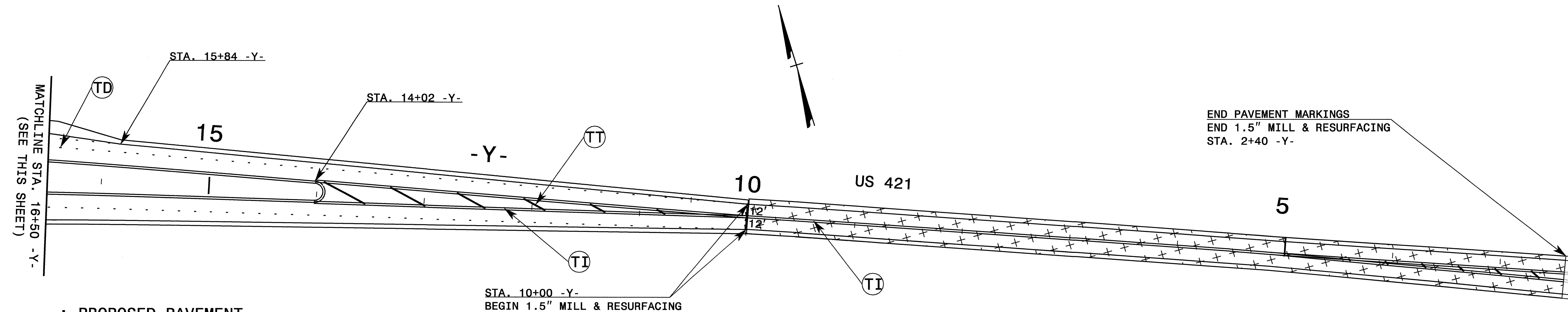
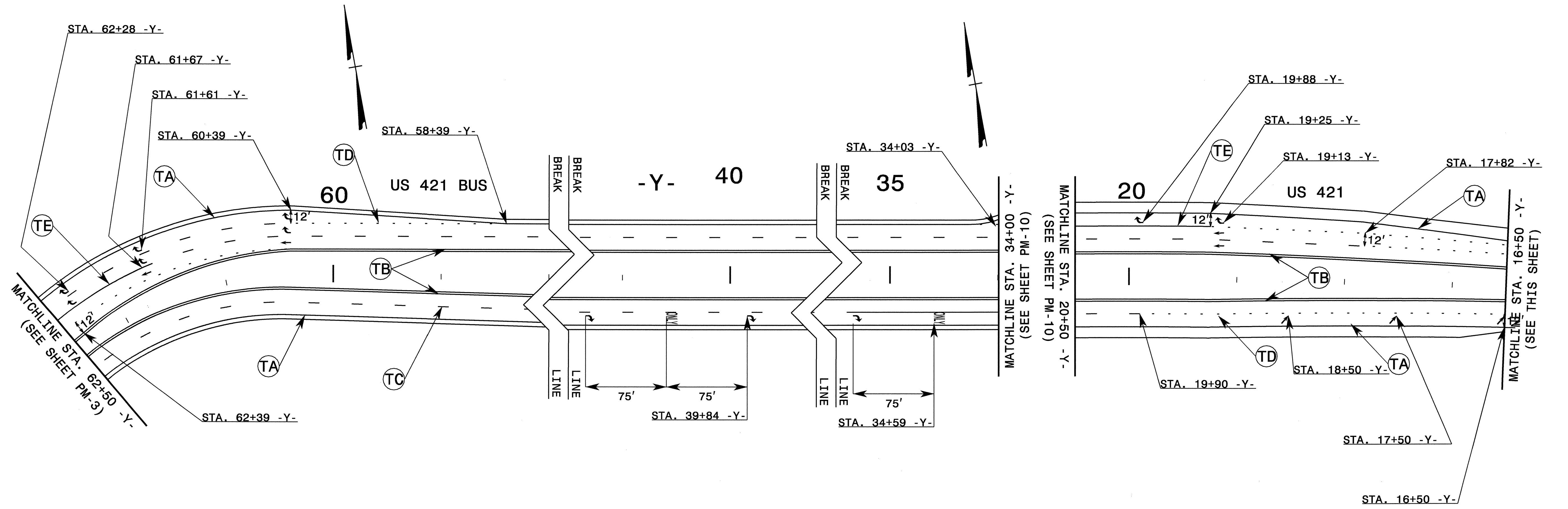

- : PROPOSED PAVEMENT MARKING LINE
- - - : EXISTING PAVEMENT MARKING LINE
- ↖ : UA ↗ : UD ↕ : UG
- ↘ : UB ↙ : UE
- : UC ↔ : UF
- ↪ : EXISTING PAVEMENT MARKING SYMBOL

NOTE: ALL LANE DIMENSIONS ARE 12' UNLESS NOTED ON PLAN SHEETS.



APPROVED: <i>[Signature]</i> DATE: 9/01/09	FINAL PAVEMENT MARKING PLAN	
SEAL		
	DATE: 08/09	
	DWG. BY: DAH	
	DESIGN BY: DAH	
REVIEWED BY: JWW		

01-SEP-2009 14:53
 \\dot\dfs\c001\NSP\proj\N\Tipp\projects-r\2417c\traffic\control\top\pmp\N-r-2417c-tc-tp-pmp-09.dgn
 dhayes AT WZT244738

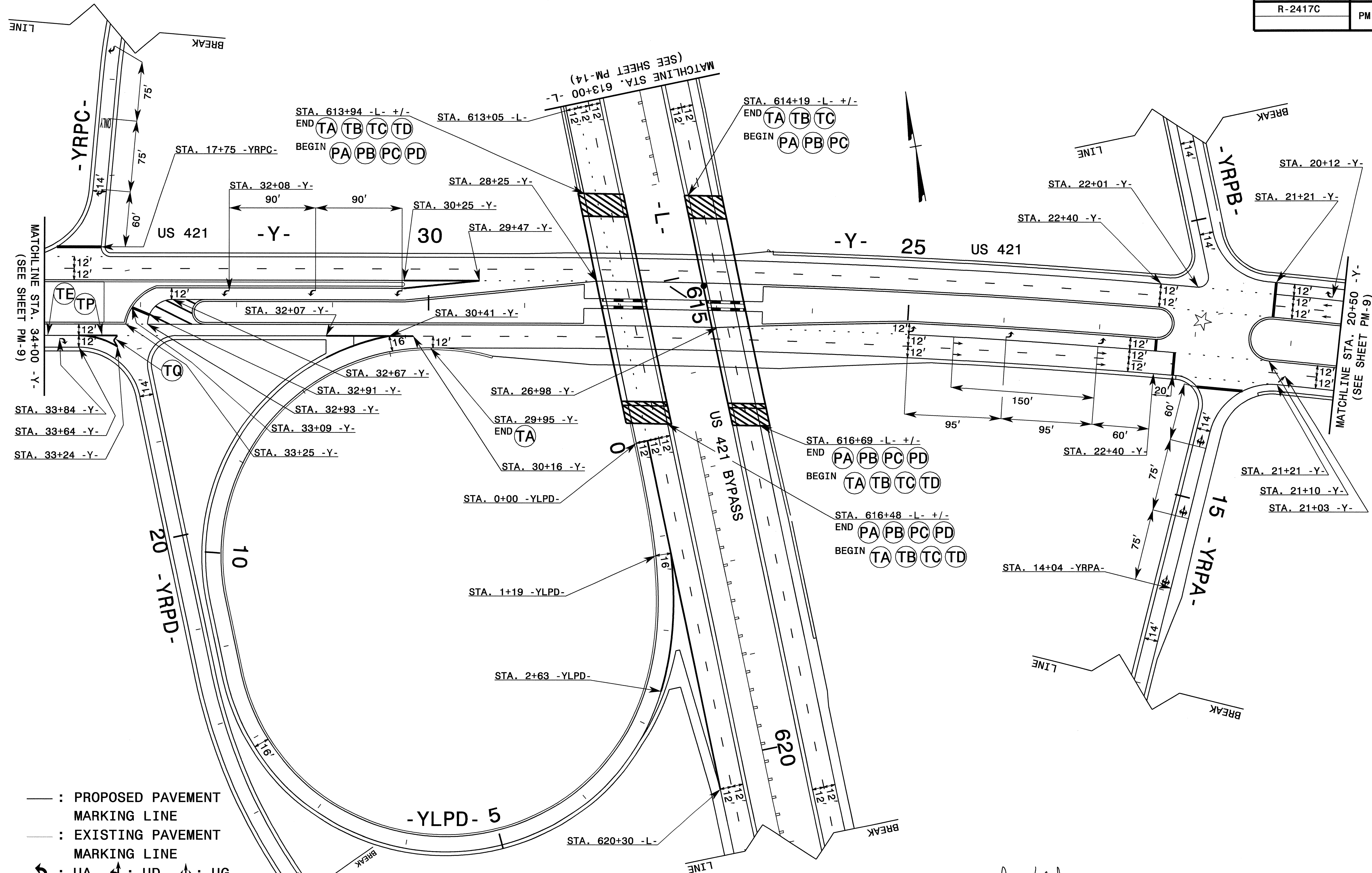

- : PROPOSED PAVEMENT MARKING LINE
- - - : EXISTING PAVEMENT MARKING LINE
- ↪ : UA ↻ : UB ↲ : UC ↻ : UD ↻ : UE ↻ : UF
- ⊕ : UG
- ⊕ : EXISTING PAVEMENT MARKING SYMBOL

APPROVED: <i>J. Woolard</i> DATE: 8/17/09	FINAL PAVEMENT MARKING PLAN									
SEAL										
	SCALE: NONE									
	DATE: 08/09									
	DWG. BY: DAH									
	DESIGN BY: DAH									
REVIEWED BY: JWW	<table border="1"> <thead> <tr> <th colspan="2">REVISIONS</th> </tr> <tr> <th>NO.</th> <th>DESCRIPTION</th> </tr> </thead> <tbody> <tr> <td> </td> <td> </td> </tr> <tr> <td> </td> <td> </td> </tr> </tbody> </table>		REVISIONS		NO.	DESCRIPTION				
REVISIONS										
NO.	DESCRIPTION									
CADD FILE										

12-AUG-2009 08:26
 \\dot\dfs\dot\NSP\Projects\11\11\projects-r\2417c\Traffic\TrafficControl\top\PM\R-2417C-TC-TC-PM-10.dgn
 ahayes AT WZTC244738

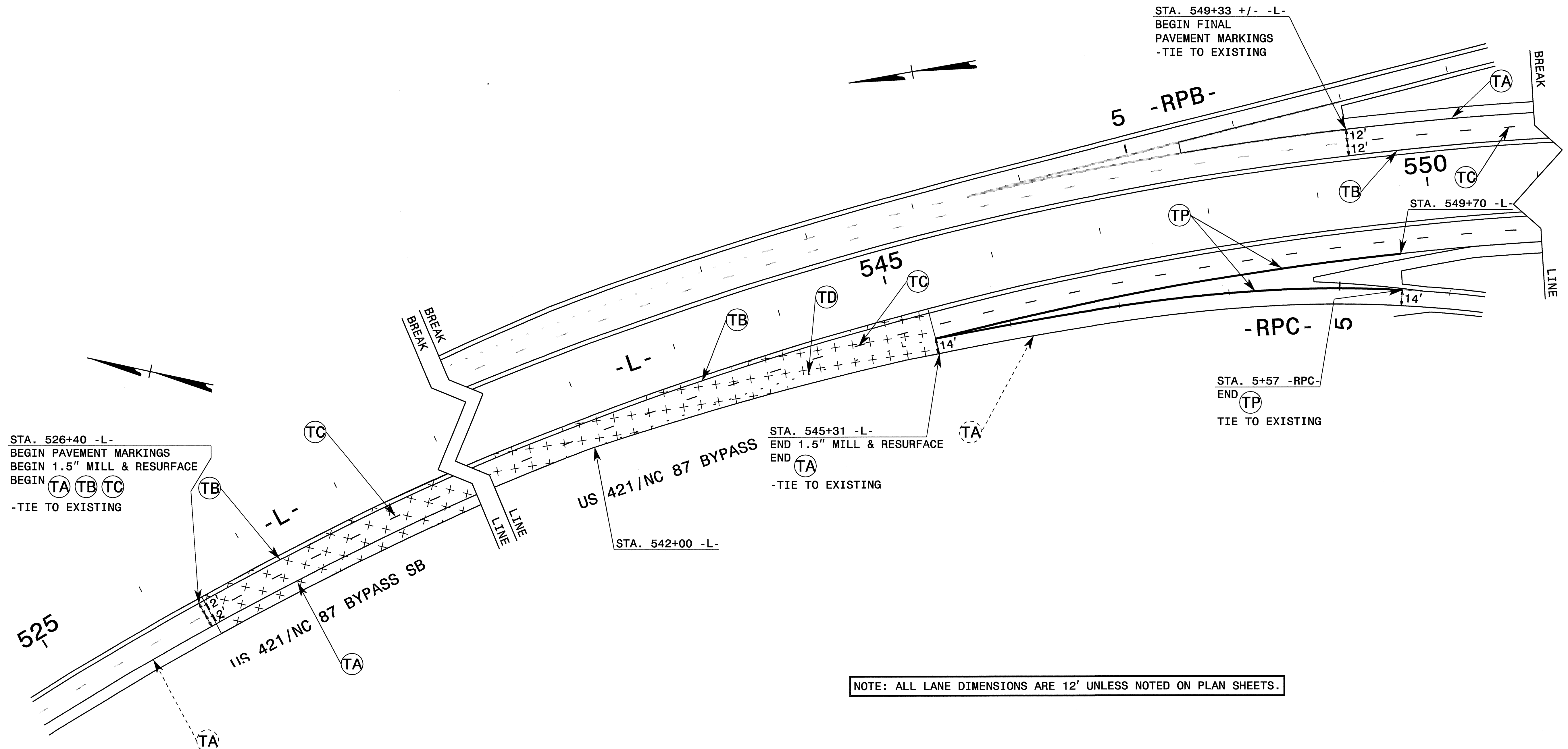

STA. 526+40 -L-
 BEGIN PAVEMENT MARKINGS
 BEGIN 1.5" MILL & RESURFACE
 BEGIN (TA) (TB) (TC)
 -TIE TO EXISTING

STA. 545+31 -L-
 END 1.5" MILL & RESURFACE
 END (TA)
 -TIE TO EXISTING

STA. 549+33 +/- -L-
 BEGIN FINAL
 PAVEMENT MARKINGS
 -TIE TO EXISTING

STA. 5+57 -RPC-
 END (TP)
 TIE TO EXISTING

NOTE: ALL LANE DIMENSIONS ARE 12' UNLESS NOTED ON PLAN SHEETS.

- : PROPOSED PAVEMENT MARKING LINE
- : EXISTING PAVEMENT MARKING LINE
- ↖ : UA ↕ : UD ↗ : UG
- ↘ : UB ↖ : UE
- ↕ : UC ↘ : UF
- ↔ : EXISTING PAVEMENT MARKING SYMBOL

- (X) EXISTING MARKINGS
- [X X] MILL AND RESURFACE

APPROVED: *[Signature]* DATE: 9/21/09

SEAL

FINAL PAVEMENT MARKING PLAN

SCALE: NONE		REVISIONS
DATE: 08/09		
DWG. BY: DAH		
DESIGN BY: DAH		
REVIEWED BY: JWW		

CADD FILE

01-SEP-2009 14:52
 \\dot\dfs\0010\NSProj\Traffic\TrafficControl\top\pmp\pmp\2417c\to_top_pmp.ilcgn
 AT WZTC241738

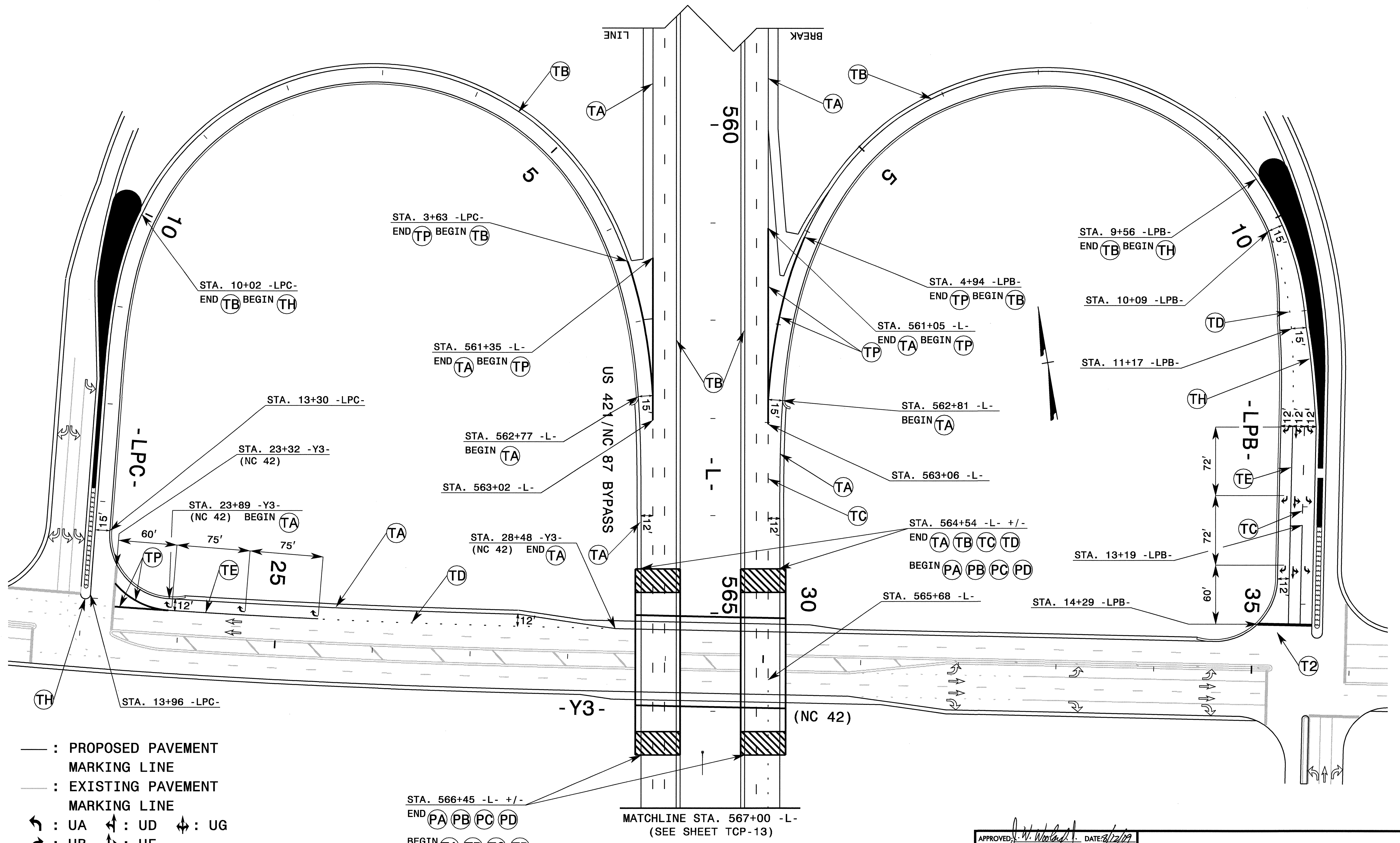

- : PROPOSED PAVEMENT MARKING LINE
- - : EXISTING PAVEMENT MARKING LINE
- ↖ : UA ↗ : UD ↘ : UG
- ↙ : UB ↕ : UE
- : UC ↖ : UF
- : EXISTING PAVEMENT MARKING SYMBOL

STA. 566+45 -L- +/-
END (PA) (PB) (PC) (PD)
BEGIN (TA) (TB) (TC) (TD)

MATCHLINE STA. 567+00 -L-
(SEE SHEET TCP-13)

NOTE: ALL LANE DIMENSIONS ARE 12' UNLESS NOTED ON PLAN SHEETS.

APPROVED: *J. W. Woolard* DATE: 8/12/09

SEAL

FINAL PAVEMENT MARKING PLAN

SCALE:	REVISIONS
NONE	
DATE: 08/09	
DWG. BY: DAH	
DESIGN BY: DAH	
REVIEWED BY: JWW	

12-AUG-2009 08:26
 \dot\vr\sr\coo\p\NSP\p\ippr\jects-Vr2417c\Traffic\tr\ffico\tr\top\pmp\AR-2417C-TC-TCP_PMP_12.dgn
 anyses AT WZ10244138

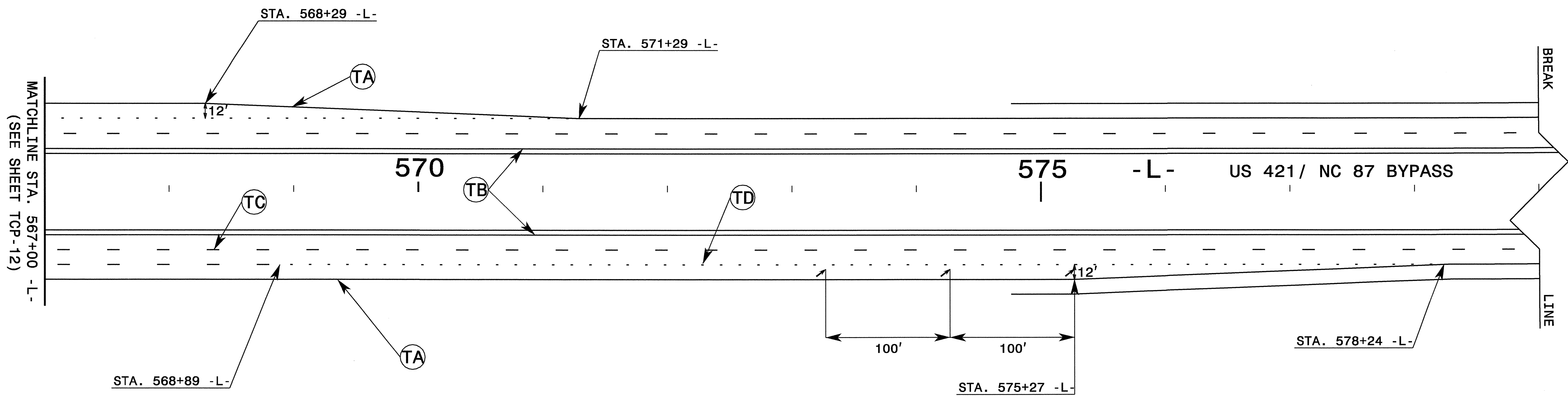

- : PROPOSED PAVEMENT MARKING LINE
- : EXISTING PAVEMENT MARKING LINE
- ↖ : UA ↗ : UD ↘ : UG
- ↙ : UB ↖ : UE
- ↕ : UC ↗ : UF
- : EXISTING PAVEMENT MARKING SYMBOL

NOTE: ALL LANE DIMENSIONS ARE 12' UNLESS NOTED ON PLAN SHEETS.

APPROVED: <i>J.W. Woolard</i> DATE: 8/12/09	FINAL PAVEMENT MARKING PLAN						
SEAL			SCALE: NONE				
	DATE: 08/09						
	DESIGN BY: DAH		<table border="1"> <tr> <th colspan="2">REVISIONS</th> </tr> <tr> <td> </td> <td> </td> </tr> </table>	REVISIONS			
	REVISIONS						
REVIEWED BY: JWW							

12-AUG-2009 08:25
 \\dot\dfsroot\01\NSP\01\ipproj\proj\2417c\tr\affio\tr\affiocontrol\top\pmp\R-2417C_TCP_PMP_13.dgn
 at 12/12/241738

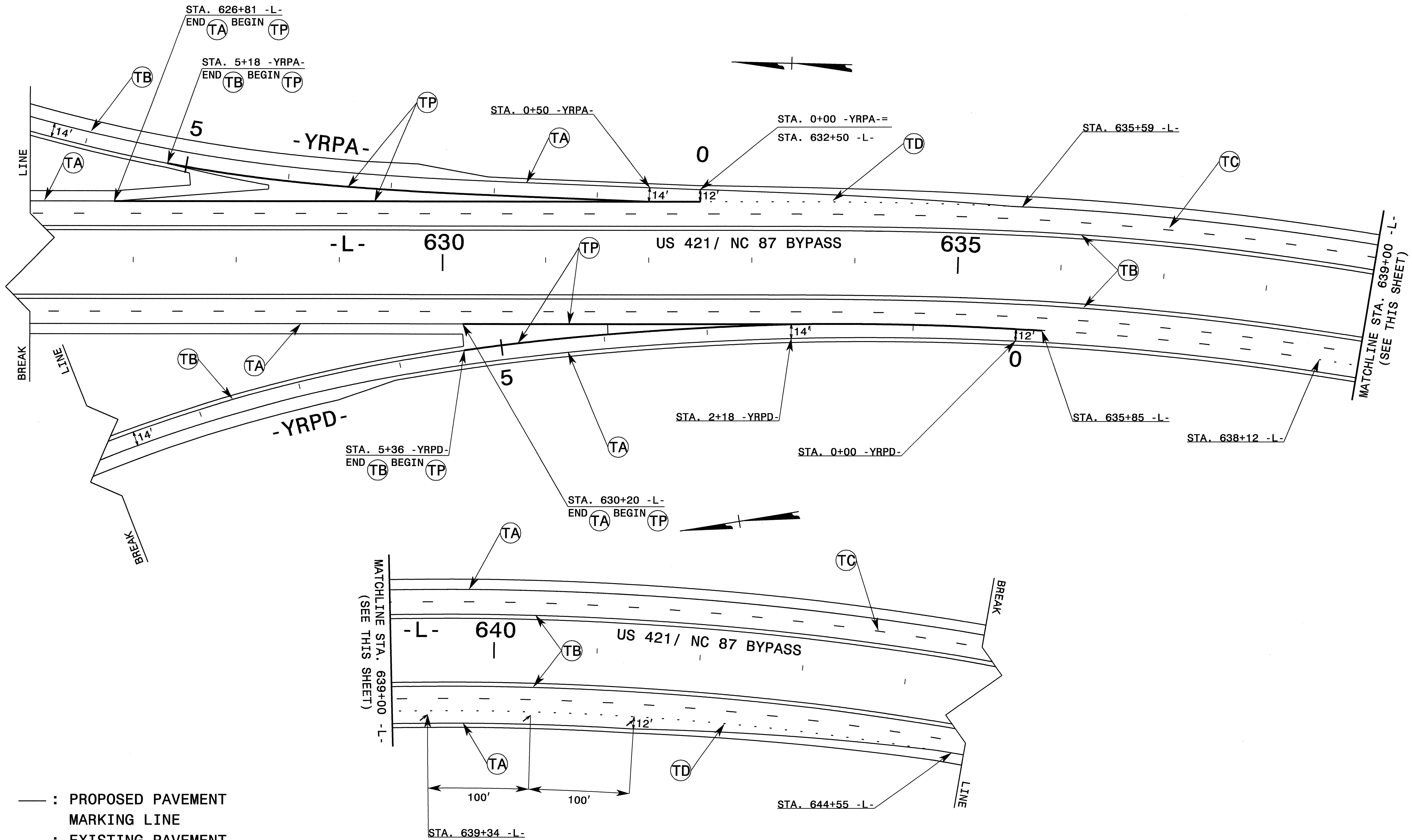

- : PROPOSED PAVEMENT MARKING LINE
- - - : EXISTING PAVEMENT MARKING LINE
- ↖ : UA ↗ : UD ↘ : UG
- ↙ : UB ↖ : UE
- : UC ↗ : UF
- : EXISTING PAVEMENT MARKING SYMBOL

NOTE: ALL LANE DIMENSIONS ARE 12' UNLESS NOTED ON PLAN SHEETS.

APPROVED: <i>J.W. Woodard</i> DATE: 3/12/09		FINAL PAVEMENT MARKING PLAN	
SCALE: NONE	REVISIONS		
DATE: 08/09			
DWG. BY: DAH			
DESIGN BY: DAH			
REVIEWED BY: JWW			