

T.I.P.: R-4737

STATE OF NORTH CAROLINA  
DEPARTMENT OF TRANSPORTATION

PAVEMENT MARKING PLANS  
WILSON COUNTY

LOCATION: US 264 AT SR 1602 (OLD STANTONSBURG ROAD)

TIP NO.	SHEET NO.
R-4737	PMP-1
APPROVED: <i>Ayman Alqudwah</i>	
DATE: 7/22/09	
SEAL	



**ROADWAY STANDARD DRAWING**

THE FOLLOWING ROADWAY STANDARDS AS APPEAR IN "ROADWAY STANDARD DRAWINGS" - PROJECT SERVICES UNIT - N.C. DEPARTMENT OF TRANSPORTATION - RALEIGH, N.C., DATED JULY 2006 ARE APPLICABLE TO THIS PROJECT AND BY REFERENCE HEREBY ARE CONSIDERED A PART OF THESE PLANS:

STD. NO.	TITLE
1205.01	PAVEMENT MARKINGS - LINE TYPES AND OFFSETS
1205.02	PAVEMENT MARKINGS - 2 LANE AND MULTILANE ROADWAYS
1205.04	PAVEMENT MARKINGS - INTERSECTIONS
1205.05	PAVEMENT MARKINGS - TURN LANES
1205.08	PAVEMENT MARKINGS - SYMBOL AND WORD MESSAGES
1205.09	PAVEMENT MARKINGS - PAINTED ISLANDS
1205.12	PAVEMENT MARKINGS - BRIDGES
1250.01	PAVEMENT MARKER SPACING
1261.01	GUARDRAIL AND BARRIER DELINEATOR SPACING
1261.02	GUARDRAIL AND BARRIER DELINEATOR TYPES
1262.01	GUARDRAIL END DELINEATION

**GENERAL NOTES**

THE FOLLOWING GENERAL NOTES APPLY AT ALL TIMES FOR THE DURATION OF THE CONSTRUCTION PROJECT, EXCEPT WHEN OTHERWISE NOTED IN THE PLAN, OR DIRECTED BY THE ENGINEER.

- A) INSTALL PAVEMENT MARKINGS AND PAVEMENT MARKERS ON THE FINAL SURFACE AS FOLLOWS:

ROAD NAME	MARKING	MARKER
ALL	THERMOPLASTIC	RAISED
- B) TIE PROPOSED PAVEMENT MARKING LINES TO EXISTING PAVEMENT MARKING LINES.
- C) REMOVE/REPLACE ANY CONFLICTING/DAMAGED PAVEMENT MARKINGS AND MARKERS.
- D) REMOVE ALL RESIDUE AND SURFACE LAITANCE BY ACCEPTABLE METHODS ON THE BRIDGE DECK PRIOR TO PLACING THERMOPLASTIC PAVEMENT MARKING.

**PLAN PREPARED BY: N.C.D.O.T. SIGNING AND DELINEATION SECTION**

AYMAN ALQUDWAH, P.E. SIGNING & DELINEATION REGIONAL ENGINEER  
D. PILLAR SIGNING & DELINEATION DESIGN ENGINEER

**INDEX**

SHEET NO.	DESCRIPTION
PMP-1	PAVEMENT MARKING PLAN COVER SHEET
PMP-2	PAVEMENT MARKING SCHEDULE
PMP-3-6	PAVEMENT MARKING DETAIL

TIP NO.	SHEET NO.
R-4737	PMP-2
APPROVED: <i>[Signature]</i>	
DATE: 7/29/09	
SEAL	
	

## PAVEMENT MARKING SCHEDULE

SYMBOL AND PAVEMENT MARKING LEGEND	
<u>THERMOPLASTIC</u>	
↶	UA LEFT TURN ARROW
↷	UB RIGHT TURN ARROW
←	UC STRAIGHT ARROW

SYMBOL	DESCRIPTION	QUANTITY BREAKDOWN	TOTAL QUANTITY
THERMOPLASTIC (4", 90 MILS) Standard Glass Beads			
TA	WHITE EDGELINE		3123LF
		TOTAL (4", 90 MILS)	3123 LF
THERMOPLASTIC (4", 120 MILS) Standard Glass Beads			
TD	2 FT. WHITE MINISKIP		53LF
TE	WHITE SOLID LANE LINE		762LF
TI	YELLOW DOUBLE CENTER		6568LF
		TOTAL (4", 120 MILS)	7383 LF
THERMOPLASTIC (6", 90 MILS) Standard Glass Beads			
T6	WHITE EDGELINE		11970LF
T7	YELLOW EDGELINE		11831LF
		TOTAL (6", 90 MILS)	23801 LF
THERMOPLASTIC (6", 120 MILS) Standard Glass Beads			
TJ	10 FT. WHITE SKIP		2227LF
TK	2 FT. WHITE MINISKIP		288LF
		TOTAL (6", 120 MILS)	2515 LF
THERMOPLASTIC (8", 90 MILS) Standard Glass Beads			
TT	YELLOW DIAGONAL		414LF
THERMOPLASTIC (12", 90 MILS) Standard Glass Beads			
TY	WHITE GORELINE		1816LF
THERMOPLASTIC PAVEMENT MARKING SYMBOLS (90 MILS)			
UA	LEFT TURN ARROW		4EA
UB	RIGHT TURN ARROW		4EA
UC	STRAIGHT ARROW		14EA
		TOTAL (SYMBOL 90 MILS)	22 EA
(4") PAVEMENT MARKING REMOVAL			
(4")	WHITE EDGELINE		788LF
(4")	YELLOW DOUBLE CENTER		788LF
		TOTAL (4") PAVEMENT MARKING REMOVAL	1576 LF
PERMANENT RAISED PAVEMENT MARKERS			
ML	- CRYSTAL & CRYSTAL , (@ 20 FT spacing, w/1 extra)		92EA

TIP NO. R-4737	SHEET NO. PMP-3
APPROVED: <i>[Signature]</i>	
DATE: 7/29/09	
SEAL	
	

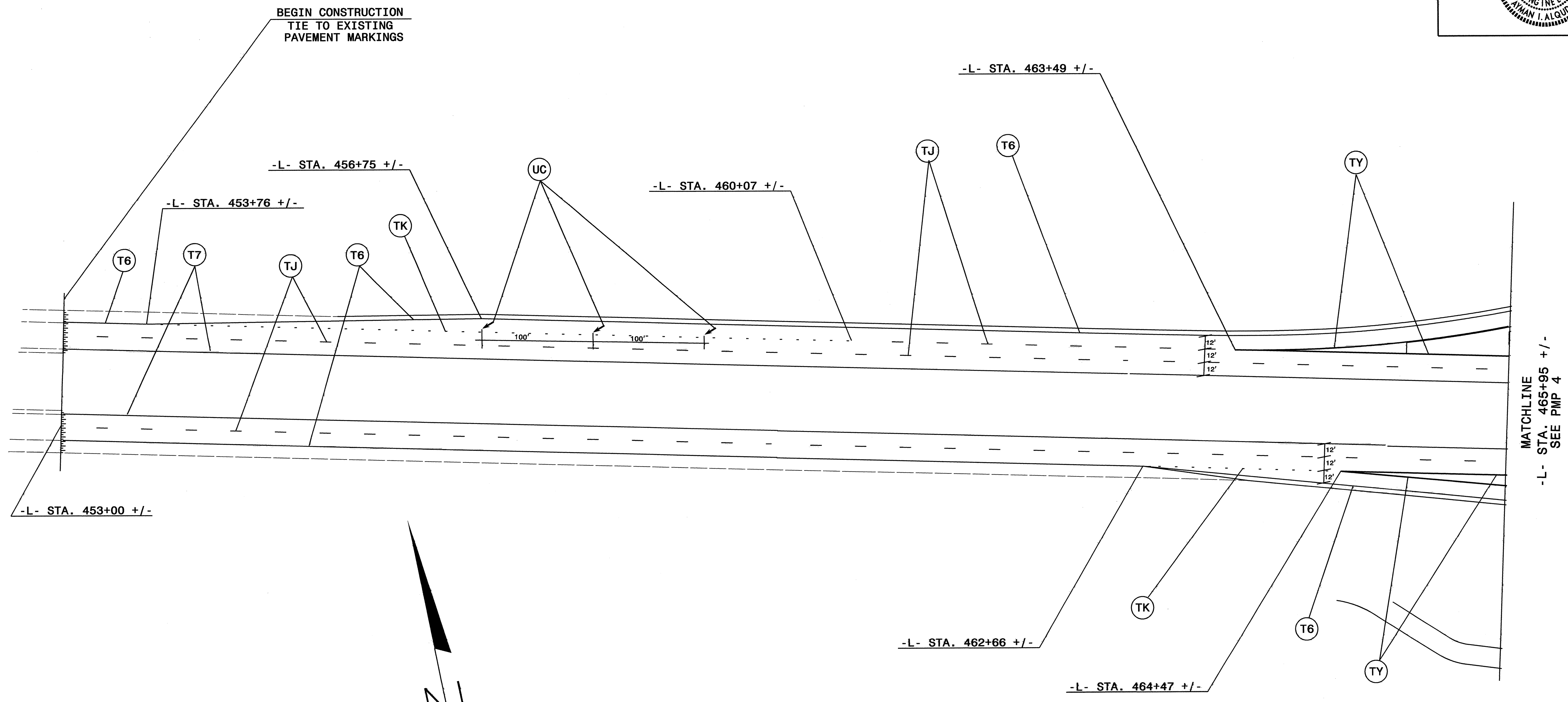

**PAVEMENT MARKING DETAIL**

TIP NO.	SHEET NO.
R-4737	PMP-4
APPROVED: <i>[Signature]</i>	
DATE: 7/29/09	
SEAL	

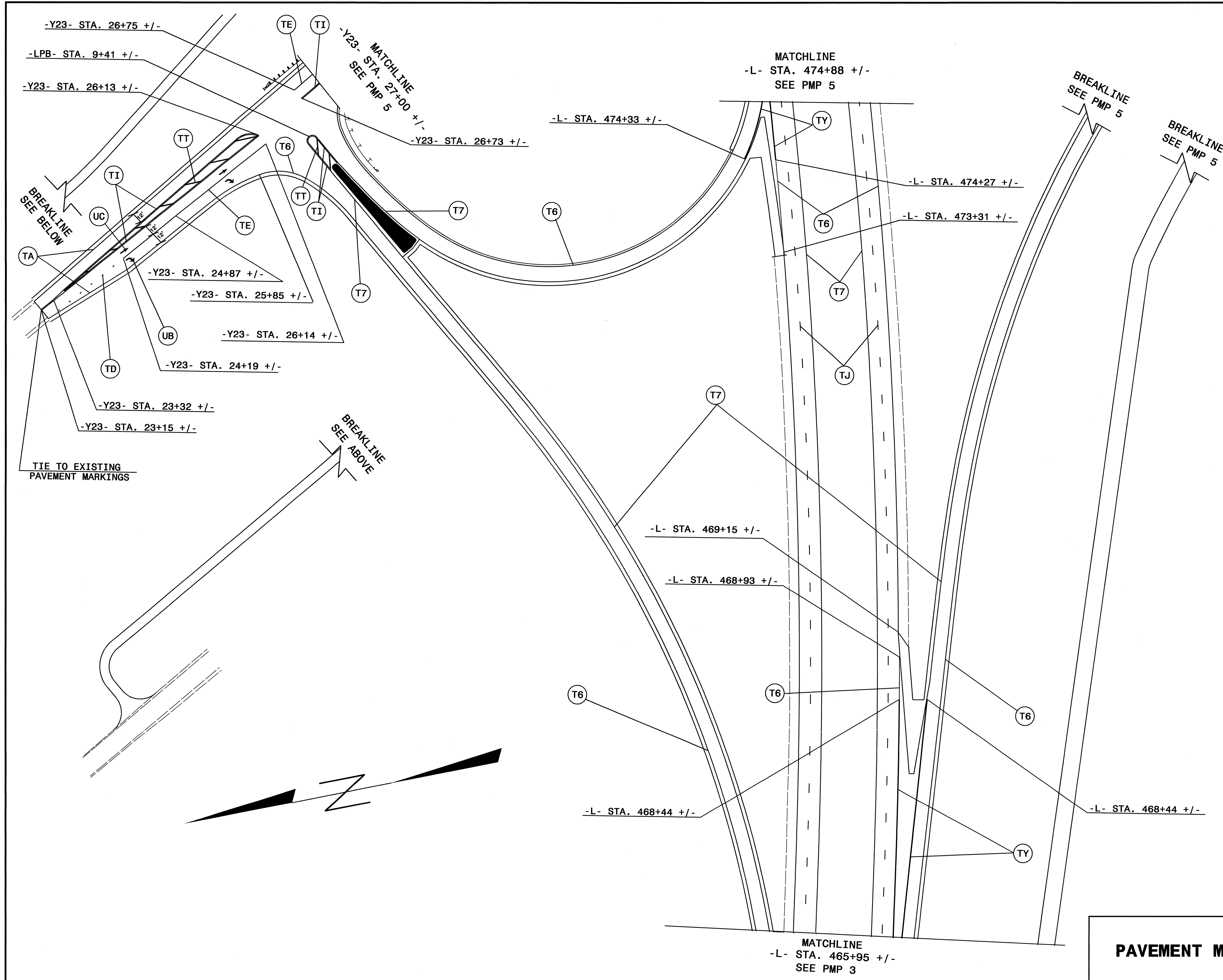

**PAVEMENT MARKING DETAIL**



TIP NO.	SHEET NO.
R-4737	PMP-5
APPROVED: <i>[Signature]</i>	
DATE: 7/29/09	
SEAL	

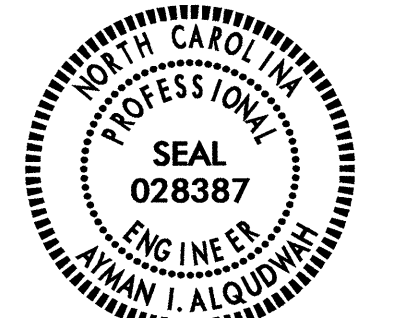

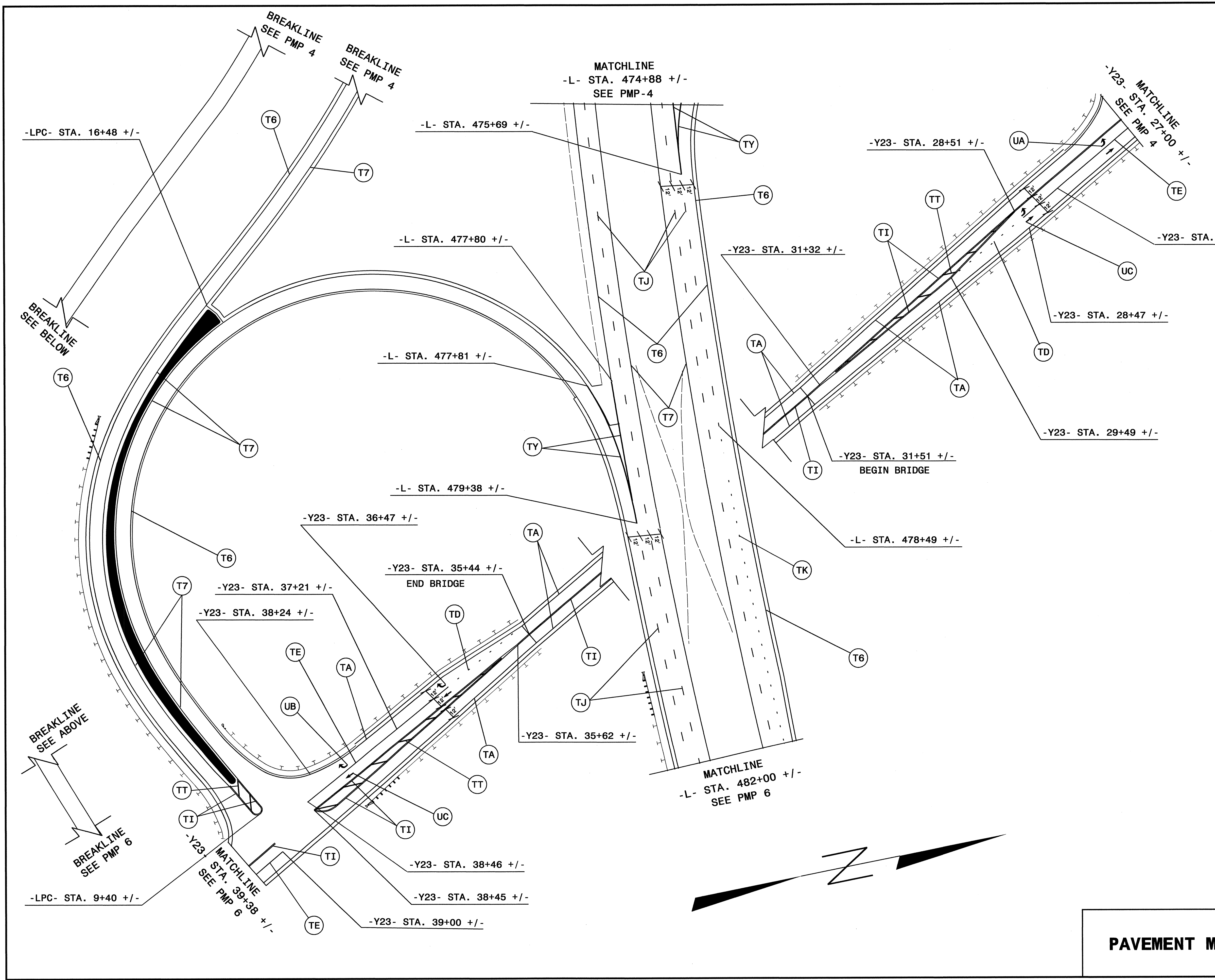

**PAVEMENT MARKING DETAIL**

TIP NO. R-4737	SHEET NO. PMP-6
APPROVED: <i>[Signature]</i>	
DATE: 7/29/09	
SEAL	

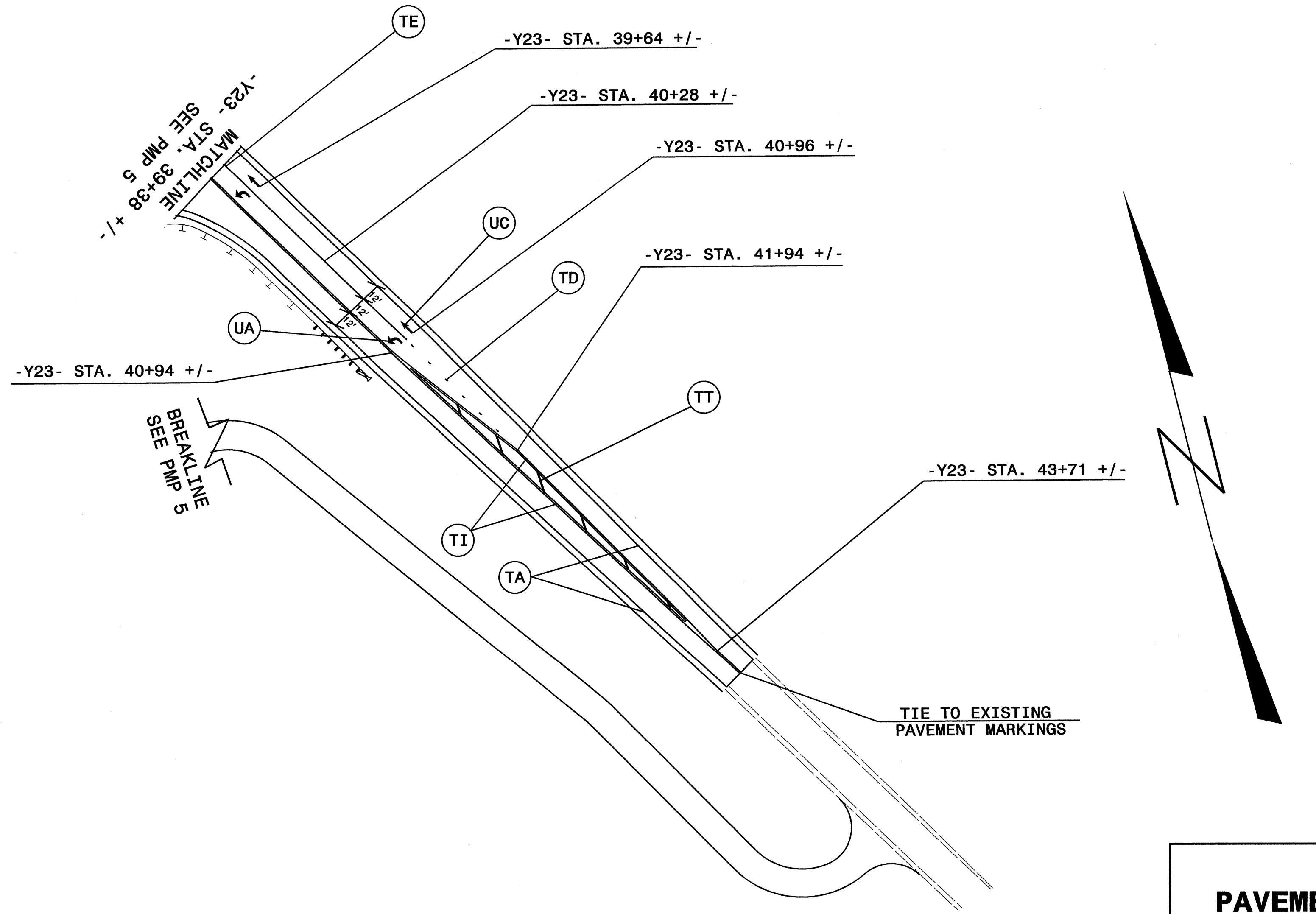
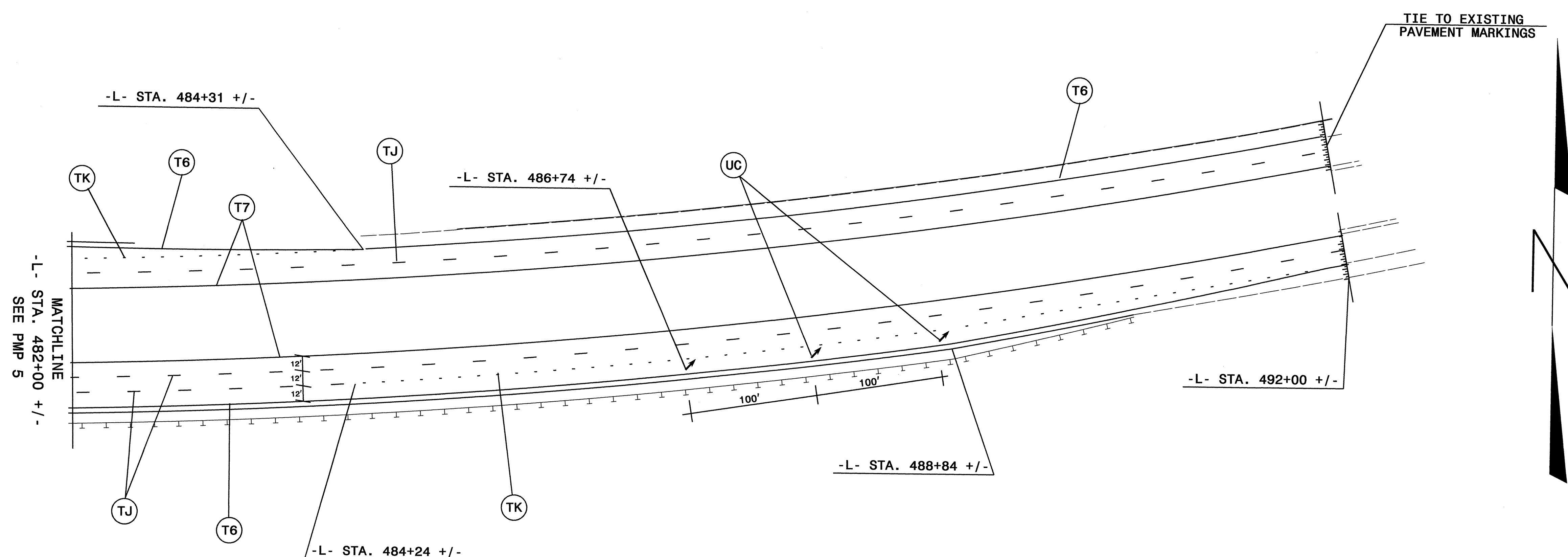

**PAVEMENT MARKING DETAIL**