



SYMBOL	DESCRIPTION
FINAL PAVEMENT MARKINGS	
	POLYUREA (4") Highly Reflective Elements
VA	WHITE EDGELINE
VC	10 FT. WHITE SKIP
VD	2 FT. WHITE MINISKIP
VE	WHITE SOLID LANE LINE
VF	10 FT. YELLOW SKIP
VH	YELLOW SINGLE CENTER
VI	YELLOW DOUBLE CENTER
	POLYUREA (8") Highly Reflective Elements
VP	WHITE GORELINE
VQ	WHITE DIAGONAL
VT	YELLOW DIAGONAL
	POLYUREA (16") Highly Reflective Elements
V1	WHITE LINE, RR CROSSB
	POLYUREA (24") Highly Reflective Elements
V2	WHITE STOPBAR
	POLYUREA PAVEMENT MARKING SYMBOL Highly Reflective Elements
WA	LEFT TURN ARROW
WB	RIGHT TURN ARROW
WC	STRAIGHT ARROW
WE	COMBO STRAIGHT/RIGHT
WF	COMBO LEFT/RIGHT
WG	COMBO LEFT/RIGHT/STRAIGHT
	POLYUREA PAVEMENT MARKING CHARACTER Highly Reflective Elements
WI	ALPHANUMERIC
MARKERS	
	SNOWPLOWABLE RAISED PAVEMENT MARKERS
ME	YELLOW & YELLOW
MF	CRYSTAL & RED

19-FEB-2008 09:33
 \\dot\dfs\0070\Pro\IP\Projects-R\2502A\TrafficControl\Top\MP\N-2502A_TC_PMP_01_FinalPM5ched.dgn
 dhayes AT WZ TC22424

APPROVED: _____	DATE: _____	FINAL PAVEMENT MARKING SCHEDULE	
	SCALE: NONE	REVISIONS	
	DATE: 02/08		
	DESIGN BY: DAH		
	REVIEWED BY: JWW		
			

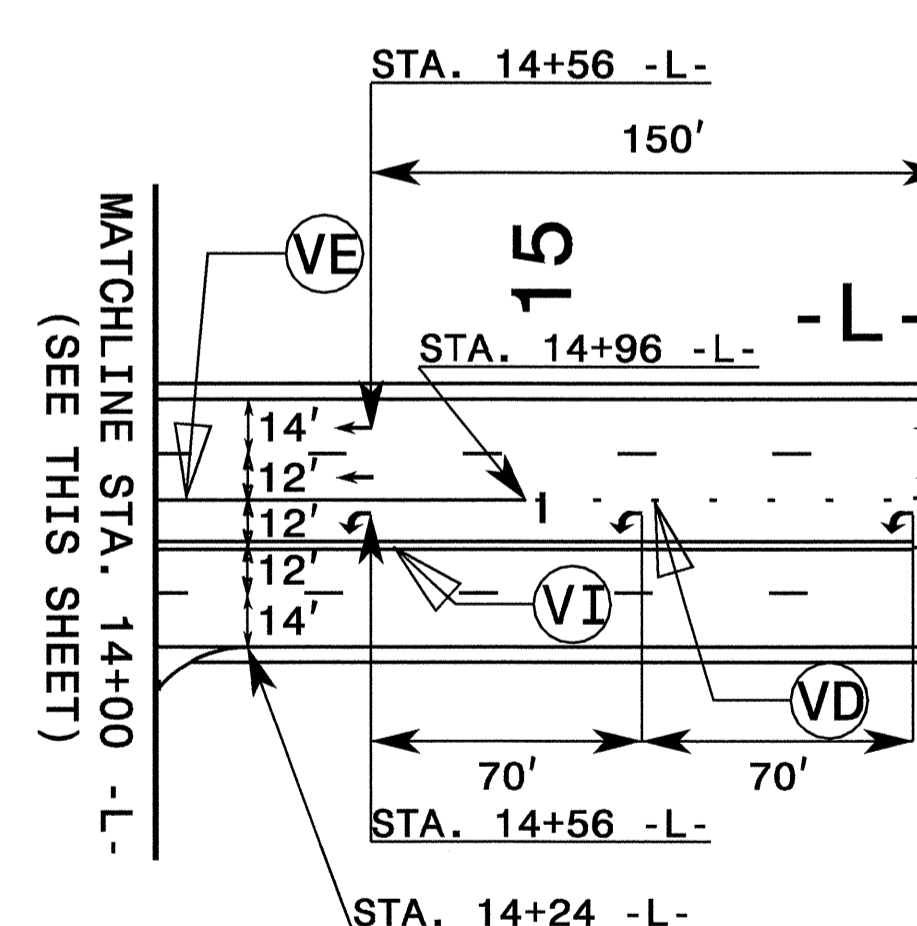
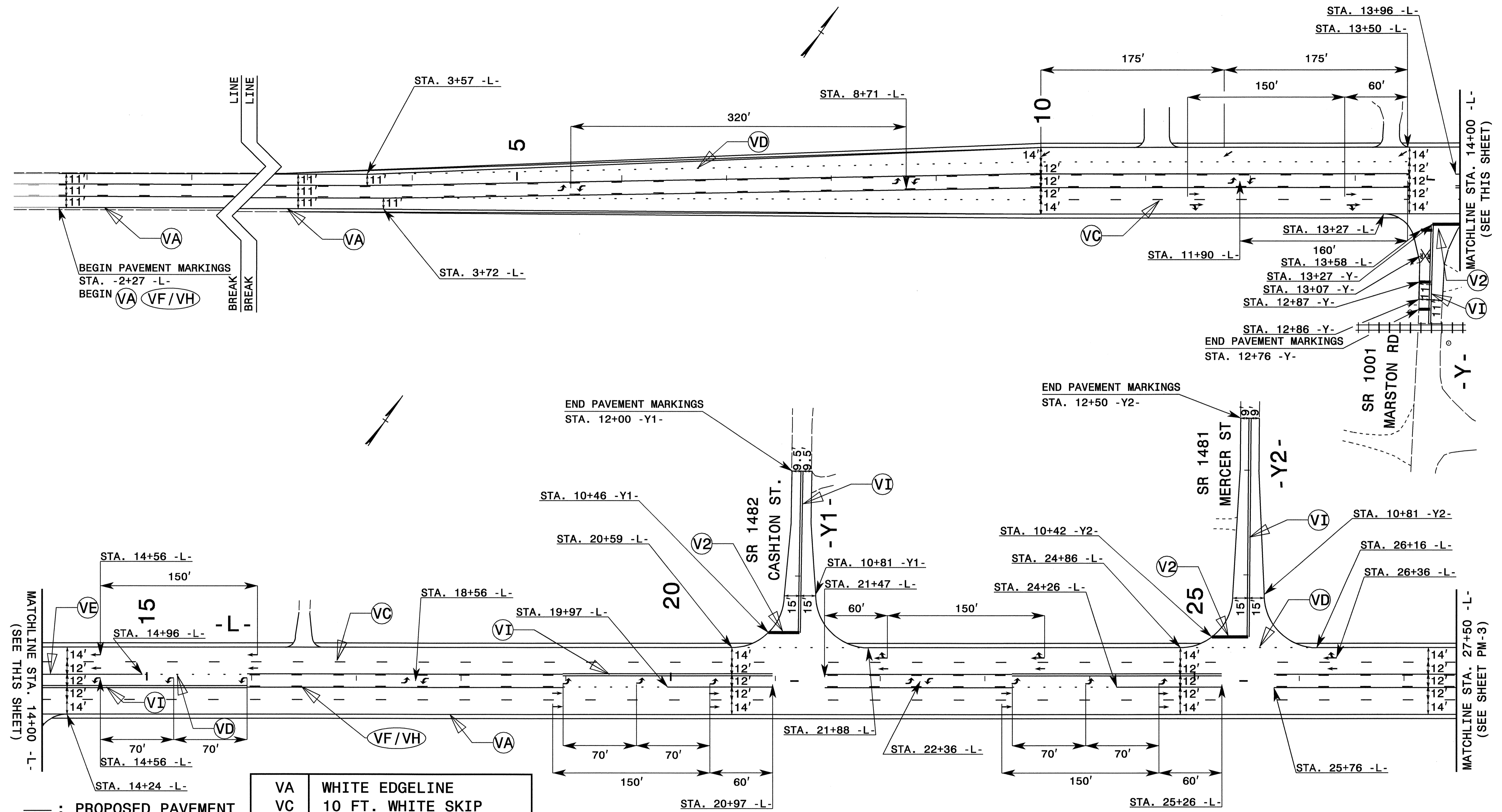

VA	WHITE EDGELINE
VC	10 FT. WHITE SKIP
VD	2 FT. WHITE MINISKIP
VE	WHITE SOLID LANE LINE
VF	10 FT. YELLOW SKIP
VH	YELLOW SINGLE CENTER
VI	YELLOW DOUBLE CENTER
VP	WHITE GORELINE
VQ	WHITE DIAGONAL
V1	WHITE LINE, RR CROSSB
V2	WHITE STOPBAR
WI	ALPHANUMERIC

- : PROPOSED PAVEMENT MARKING LINE
- - - : EXISTING PAVEMENT MARKING LINE
- ↔ : WA ↔ : WD ↔ : WG
- ↔ : WB ↔ : WE
- ↔ : WC ↔ : WF
- ↔ : EXISTING PAVEMENT MARKING SYMBOL

APPROVED: _____ DATE: _____

SEAL

2/19/08

FINAL PAVEMENT MARKING PLAN

SCALE: NONE
DATE: 02/08
DWG. BY: DAH
DESIGN BY: DAH
REVIEWED BY: JWW

REVISIONS

19-FEB-2008 09:33
 \\dot\dfs\0010\Proj\TIPProjects-R\2502A\TrafficControl\top\PMF\R-2502A-TC-PM-02.dgn
 ahayas AT WZTC24241

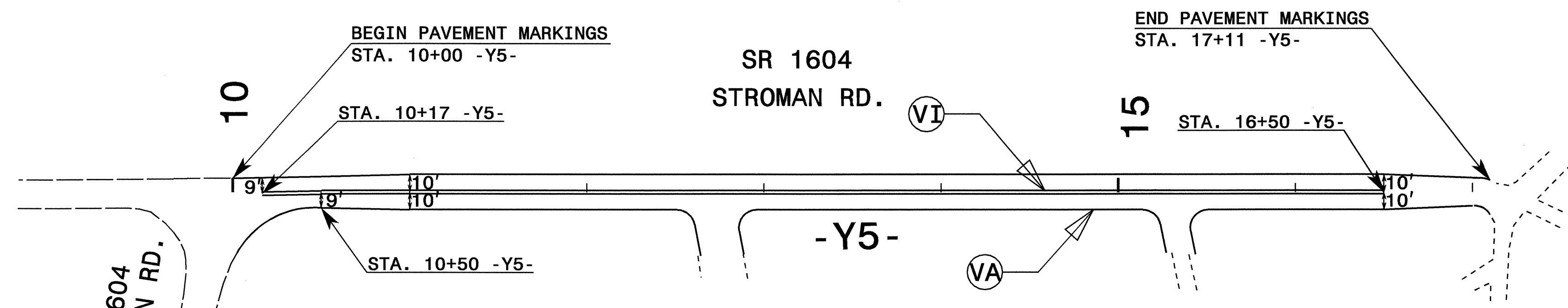
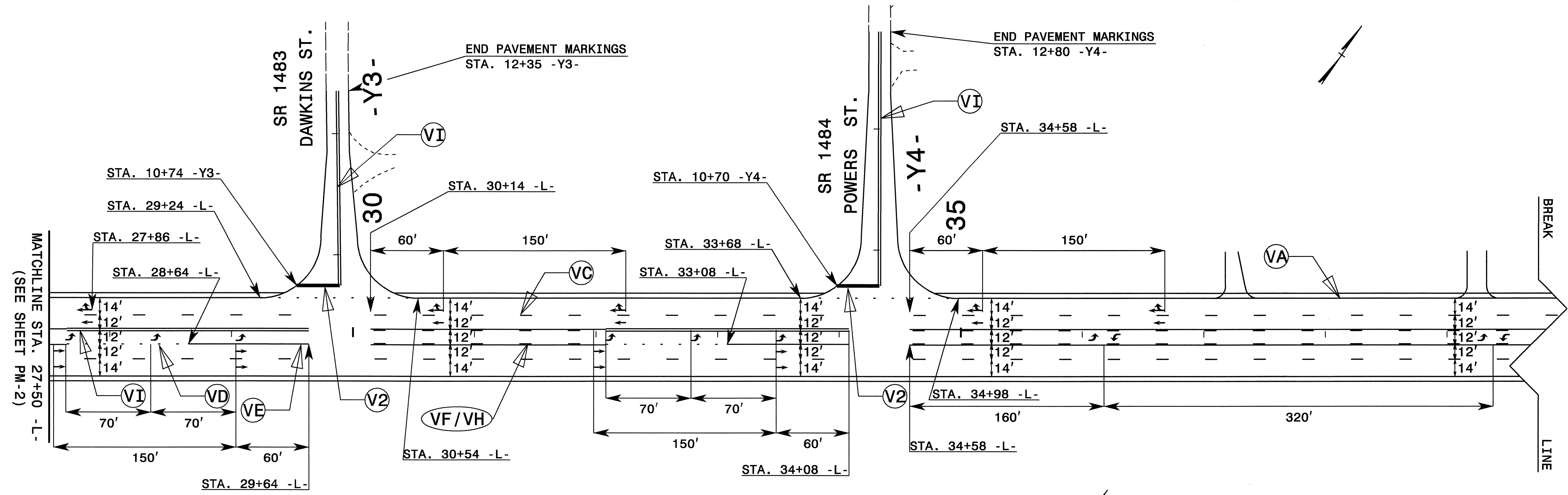

— : PROPOSED PAVEMENT MARKING LINE	VA : WHITE EDGELINE
— : EXISTING PAVEMENT MARKING LINE	VC : 10 FT. WHITE SKIP
↔ : WA ↗ : WD ↖ : WG	VD : 2 FT. WHITE MINISKIP
↔ : WB ↗ : WE	VE : WHITE SOLID LANE LINE
↔ : WC ↗ : WF	VF : 10 FT. YELLOW SKIP
↔ : EXISTING PAVEMENT MARKING SYMBOL	VH : YELLOW SINGLE CENTER
	VI : YELLOW DOUBLE CENTER
	VP : WHITE GORELINE
	VQ : WHITE DIAGONAL
	V1 : WHITE LINE, RR CROSSB
	V2 : WHITE STOPBAR
	WI : ALPHANUMERIC

APPROVED: _____ DATE: _____	FINAL PAVEMENT MARKING PLAN	
SCALE: NONE	REVISIONS	
DATE: 02/08		
DWG. BY: DAH		
DESIGN BY: DAH		
REVIEWED BY: JWW		

19-FEB-2008 09:32
 \\dot\dfsroot\01\Proj\Projects-R\2502A\TrafficControl\top\PM-3\2502A-TC_PMP_03.dgn
 ahayes AT WZTC224241

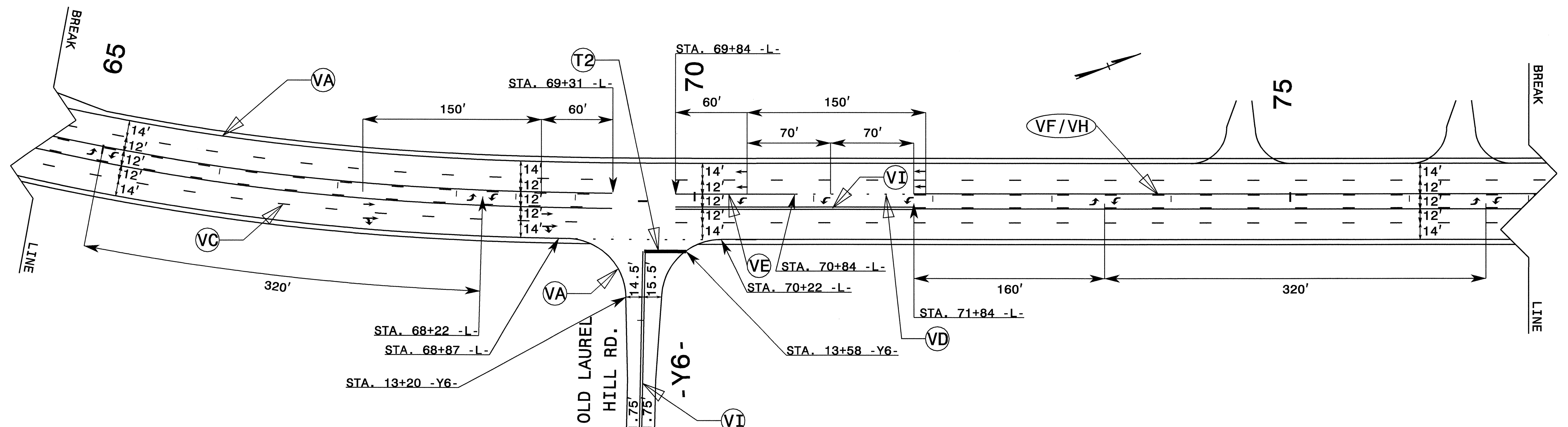

VA	WHITE EDGELINE
VC	10 FT. WHITE SKIP
VD	2 FT. WHITE MINISKIP
VE	WHITE SOLID LANE LINE
VF	10 FT. YELLOW SKIP
VH	YELLOW SINGLE CENTER
VI	YELLOW DOUBLE CENTER
VP	WHITE GORELINE
VQ	WHITE DIAGONAL
V1	WHITE LINE, RR CROSSB
V2	WHITE STOPBAR
WI	ALPHANUMERIC

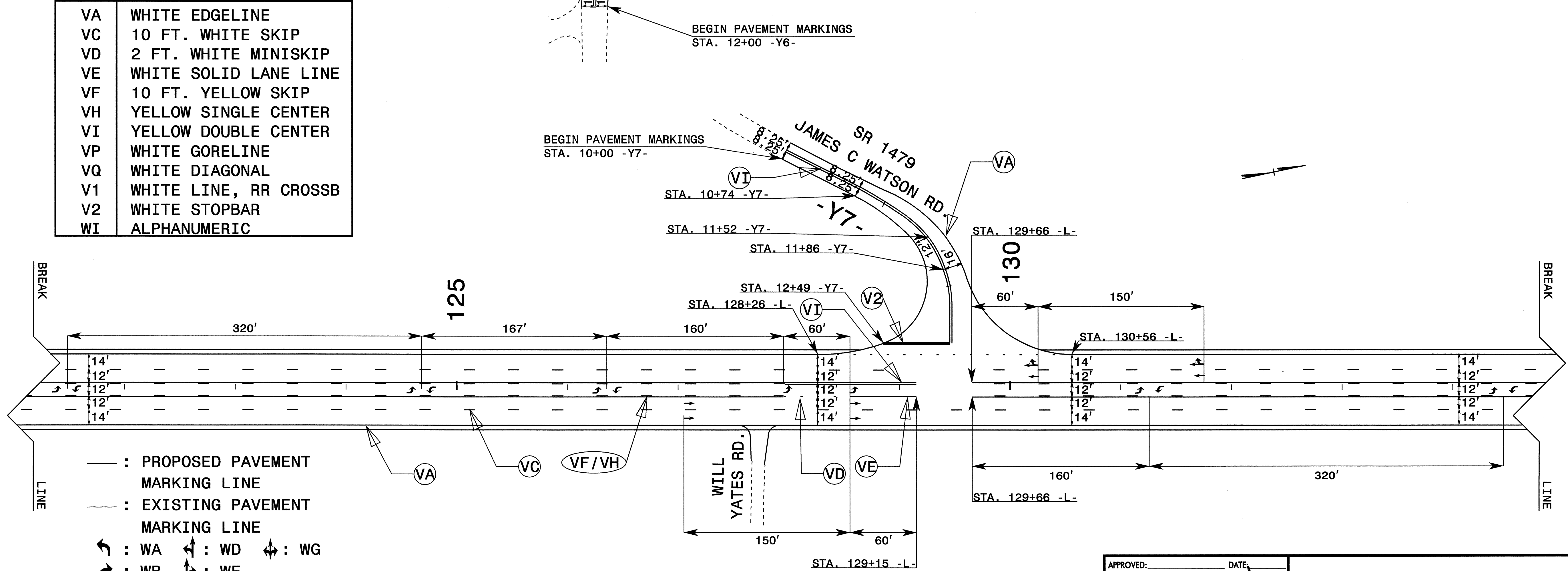

- : PROPOSED PAVEMENT MARKING LINE
- - - : EXISTING PAVEMENT MARKING LINE
- ↖ : WA ↗ : WD ↘ : WG
- ↙ : WB ↖ : WE
- : WC ↗ : WF
- ↪ : EXISTING PAVEMENT MARKING SYMBOL

APPROVED: _____ DATE: _____	FINAL PAVEMENT MARKING PLAN	
SCALE: NONE	REVISIONS	
DATE: 02/08		
DESIGN BY: DAH		
REVIEWED BY: JWW		

19-FEB-2008 09:32
 \\dot\dfsroot\proj\TIP\Projects\R2502A\TrafficControl\Top\NMP\R-2502A_TC_PMP_04.dgn
 AT WZTC224241

VA	WHITE EDGELINE
VC	10 FT. WHITE SKIP
VD	2 FT. WHITE MINISKIP
VE	WHITE SOLID LANE LINE
VF	10 FT. YELLOW SKIP
VH	YELLOW SINGLE CENTER
VI	YELLOW DOUBLE CENTER
VP	WHITE GORELINE
VQ	WHITE DIAGONAL
V1	WHITE LINE, RR CROSSB
V2	WHITE STOPBAR
WI	ALPHANUMERIC

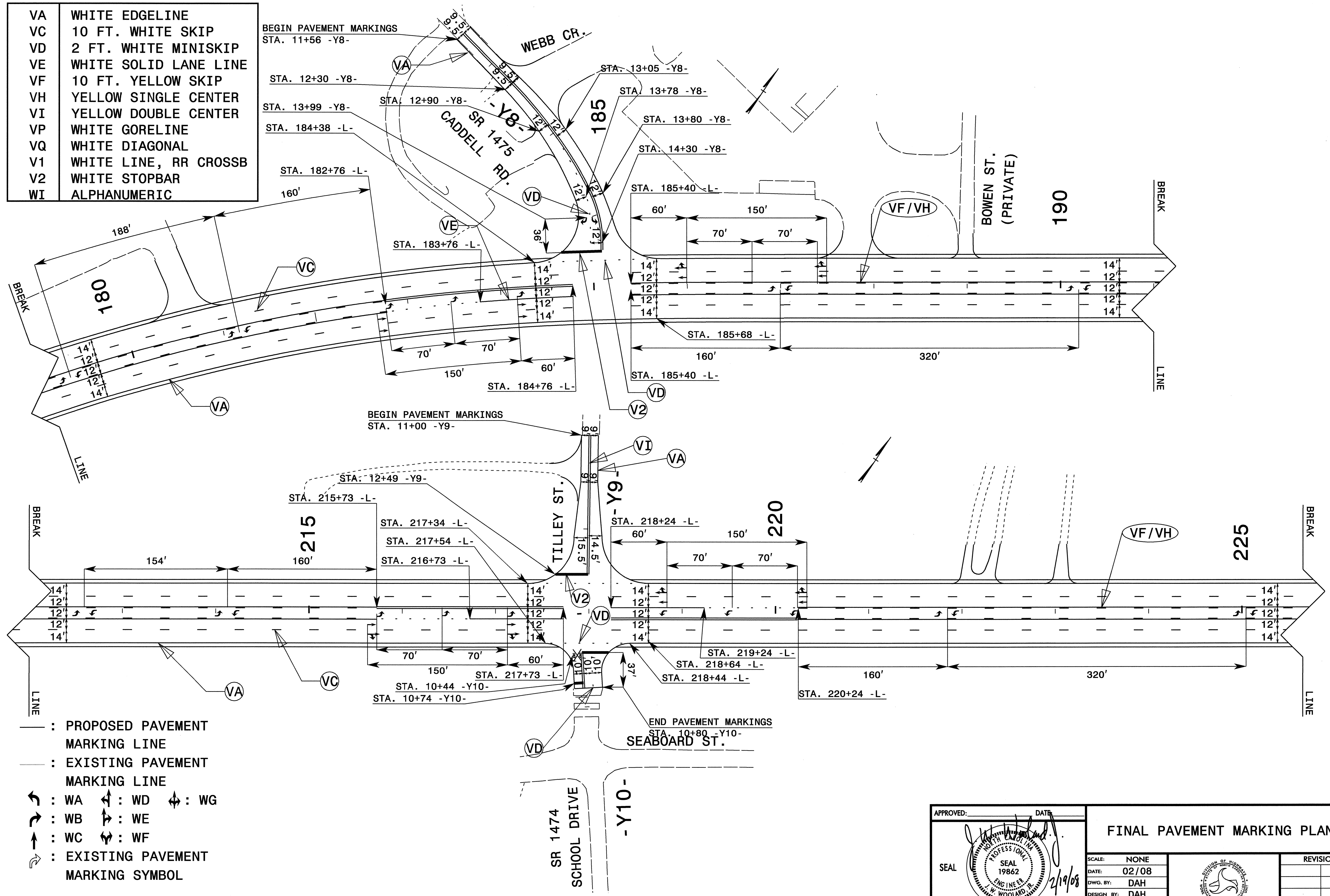

- : PROPOSED PAVEMENT MARKING LINE
- - - : EXISTING PAVEMENT MARKING LINE
- ↔ : WA ↔ : WD ↔ : WG
- ↔ : WB ↔ : WE
- ↔ : WC ↔ : WF
- ↔ : EXISTING PAVEMENT MARKING SYMBOL

19-FEB-2008 09:33Z
 \\dot\dfsroot\proj\TIP\Projects-R\R2502A\TrafficControl\top\MP\R-2502A_TC_PMP_05.dgn
 anayes AT WZTC224241

APPROVED:	DATE:	FINAL PAVEMENT MARKING PLAN									
	2/19/08										
SCALE: NONE	DATE: 02/08	<table border="1"> <thead> <tr><th colspan="2">REVISIONS</th></tr> </thead> <tbody> <tr><td> </td><td> </td></tr> <tr><td> </td><td> </td></tr> <tr><td> </td><td> </td></tr> </tbody> </table>		REVISIONS							
REVISIONS											
DWG. BY: DAH	DESIGN BY: DAH										
REVIEWED BY: JWJ		<table border="1"> <tr><td>CADD FILE</td></tr> </table>		CADD FILE							
CADD FILE											

- : PROPOSED PAVEMENT MARKING LINE
- - - : EXISTING PAVEMENT MARKING LINE
- ↖ : WA ↗ : WD ↕ : WG
- ↘ : WB ↙ : WE
- ↔ : WC ↕ : WF
- ↔ : EXISTING PAVEMENT MARKING SYMBOL

VA	WHITE EDGELINE	VI	YELLOW DOUBLE CENTER
VC	10 FT. WHITE SKIP	VP	WHITE GORELINE
VD	2 FT. WHITE MINISKIP	VQ	WHITE DIAGONAL
VE	WHITE SOLID LANE LINE	V1	WHITE LINE, RR CROSSB
VF	10 FT. YELLOW SKIP	V2	WHITE STOPBAR
VH	YELLOW SINGLE CENTER	WI	ALPHANUMERIC

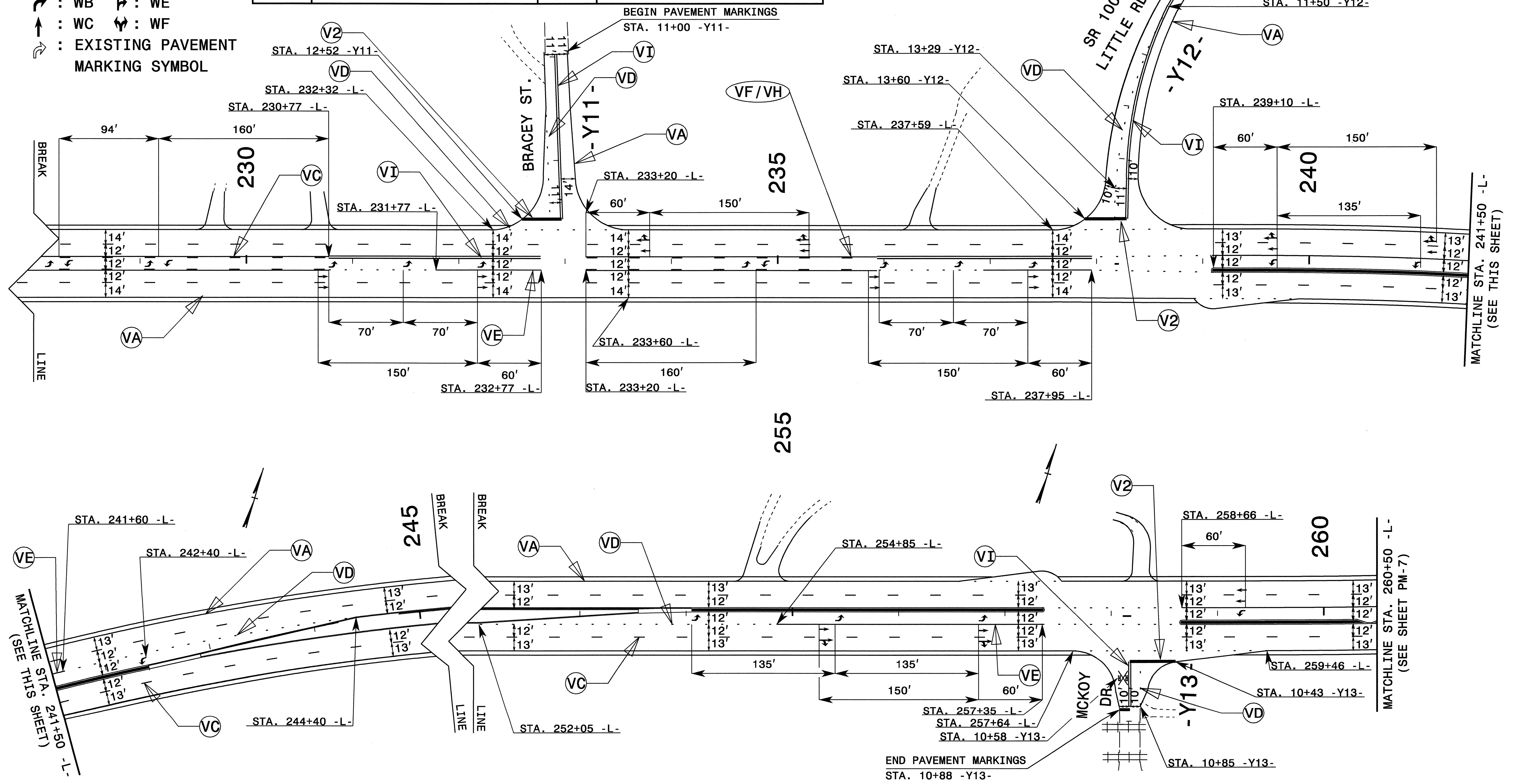

19-FEB-2008 09:31
 \\dot\dfs\0010\Proj\TIP\Projects\R2502A\TrafficControl\Top\MP\R-2502A_TC_PMP_06.dgn
 ahays AT WZTC224241

APPROVED: _____ DATE: _____	FINAL PAVEMENT MARKING PLAN	
SCALE: NONE		REVISIONS
DATE: 02/08		
DWG. BY: DAH		
DESIGN BY: DAH		
REVIEWED BY: JWW		CADD FILE

VA	WHITE EDGELINE	VI	YELLOW DOUBLE CENTER
VC	10 FT. WHITE SKIP	VP	WHITE GORELINE
VD	2 FT. WHITE MINISKIP	VQ	WHITE DIAGONAL
VE	WHITE SOLID LANE LINE	V1	WHITE LINE, RR CROSSB
VF	10 FT. YELLOW SKIP	V2	WHITE STOPBAR
VH	YELLOW SINGLE CENTER	WI	ALPHANUMERIC

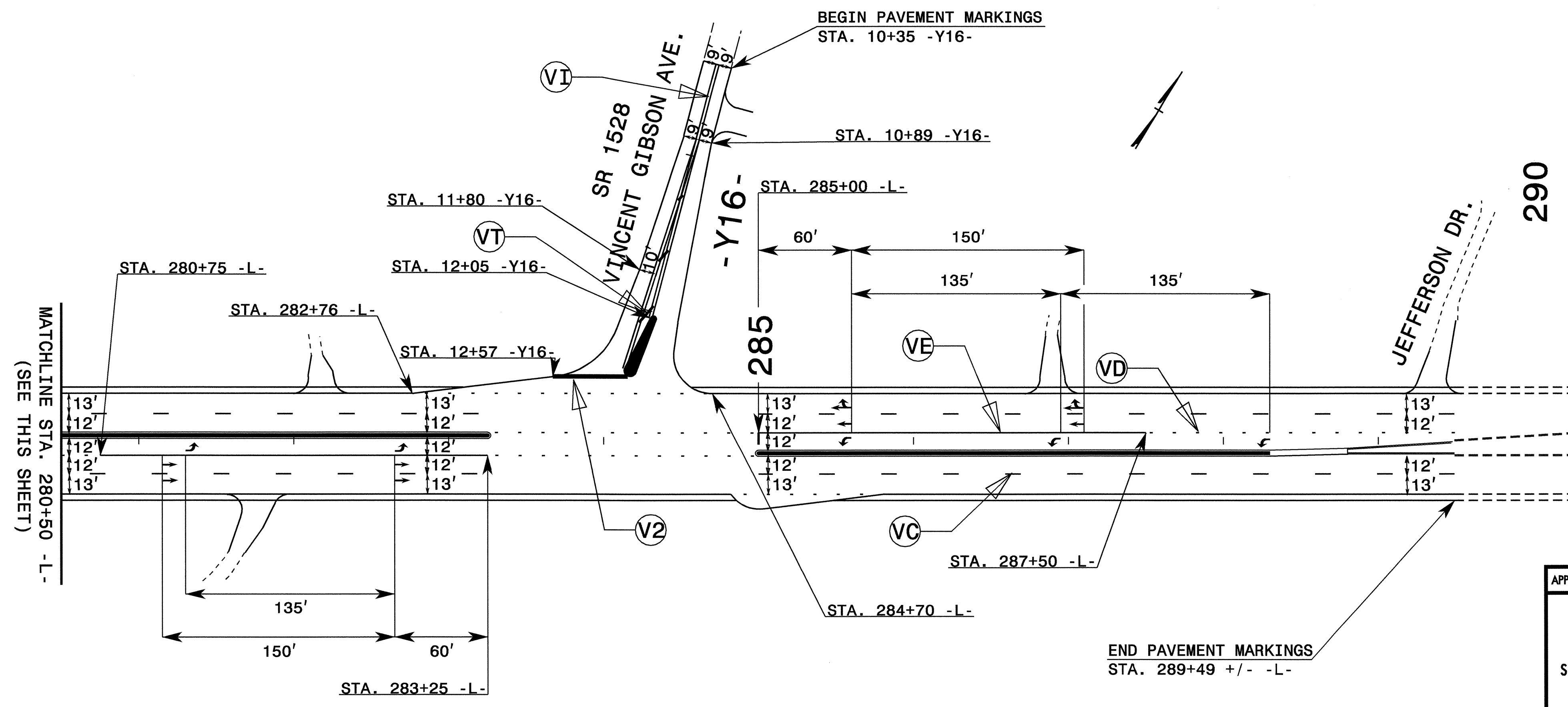
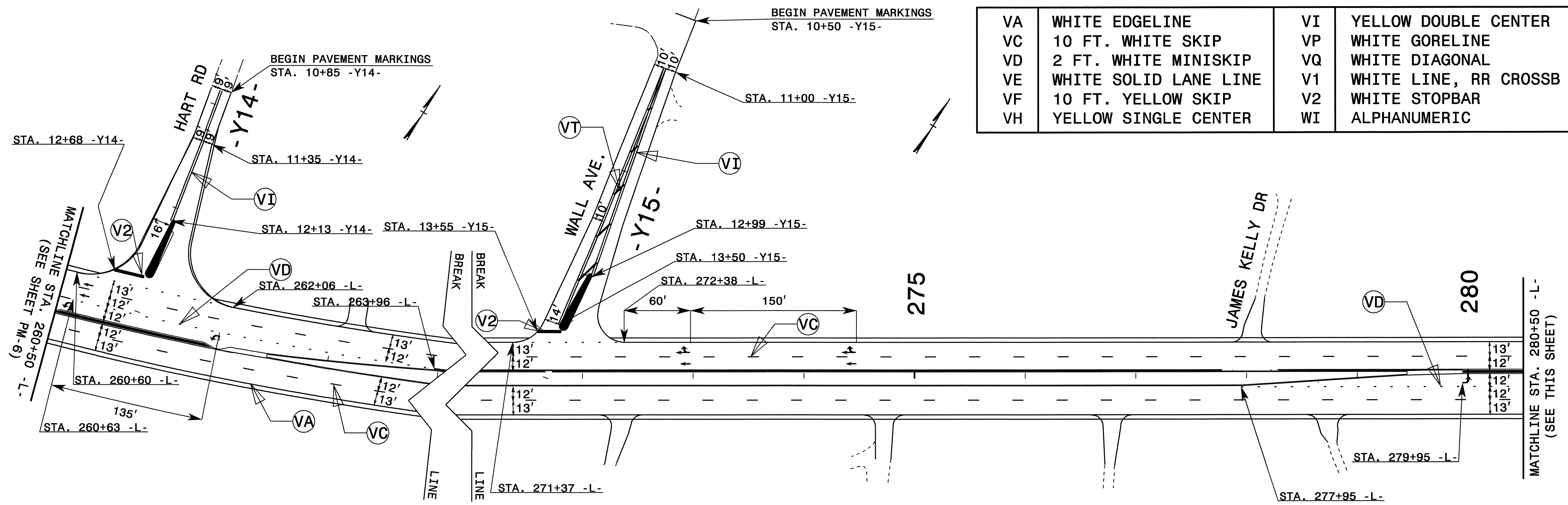

- : PROPOSED PAVEMENT MARKING LINE
- - - : EXISTING PAVEMENT MARKING LINE
- ↪ : WA ↪ : WD ↪ : WG
- ↪ : WB ↪ : WE
- ↪ : WC ↪ : WF
- ↪ : EXISTING PAVEMENT MARKING SYMBOL

APPROVED: _____ DATE: _____	FINAL PAVEMENT MARKING PLAN							
SEAL								
	SCALE: NONE DATE: 02/08 DWG. BY: DAH DESIGN BY: DAH REVIEWED BY: JWW	REVISIONS <table border="1"> <tr><td> </td><td> </td></tr> <tr><td> </td><td> </td></tr> <tr><td> </td><td> </td></tr> </table>						

19-FEB-2008 09:31
 \\dot\dfsroot\Pro\TIP\Projects-R\2502A\TrafficControl\Top\NMP\R-2502A_TC_PMP_07.dgn
 AT: WZTC224241