

STATE	STATE PROJECT REFERENCE NO.	SHEET NO.	TOTAL SHEETS
N.C.	B-4300	1	
W.A.S. ELEMENT	F.A. PROJ. NO.	DESCRIPTION	
33637.1.1	BRSTP-1007(8)	P.E.	
33637.2.1	BRSTP-1007(8)	RW, UTL.	
33637.3.1	BRSTP-1007(8)	CONST.	

STATE OF NORTH CAROLINA  
DIVISION OF HIGHWAYS

**WAKE COUNTY**

**LOCATION: BRIDGE NO. 29 OVER CLARKS CREEK ON SR 1007**  
**TYPE OF WORK: GRADING, DRAINAGE, PAVING AND CULVERT**

See Sheet 1-A For Index of Sheets  
See Sheet 1-B For Conventional Symbols

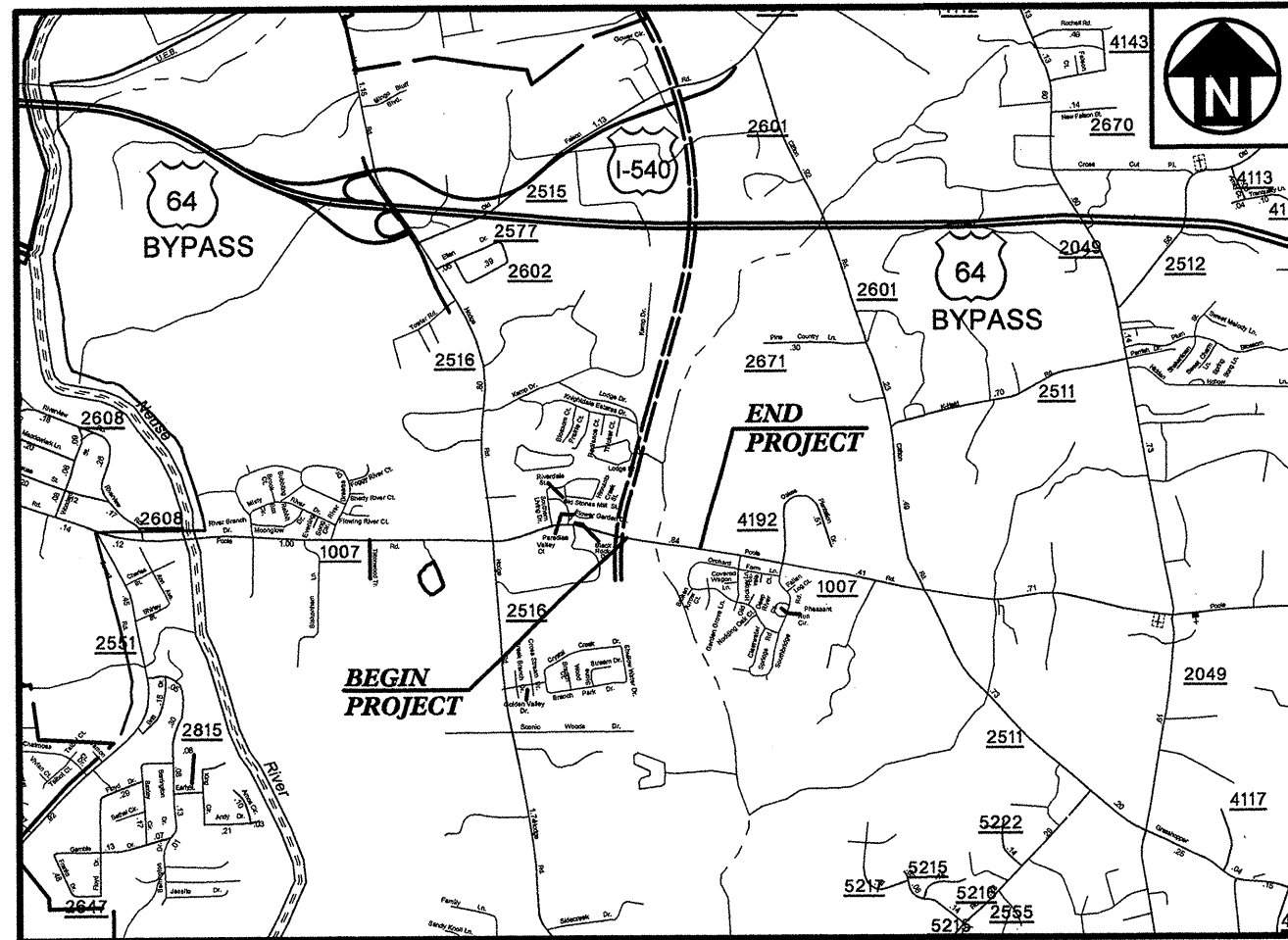

VICINITY MAP

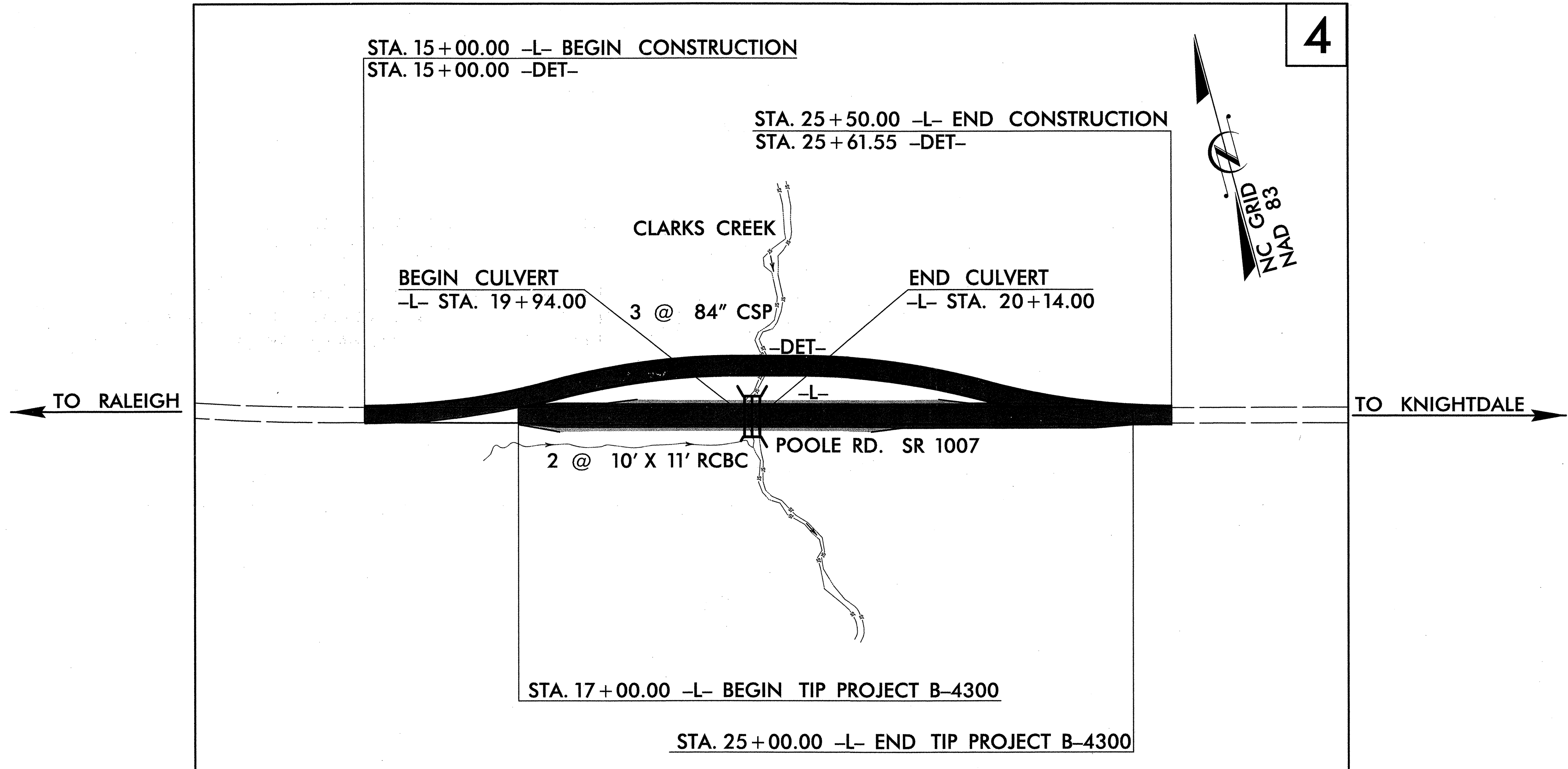

4

TIP PROJECT: B-4300

CONTRACT: C201897

**MULKEY**  
ENGINEERS & CONSULTANTS  
PO Box 33127  
RALEIGH, N.C. 27636  
(919) 851-1912  
(919) 851-1918 (FAX)  
WWW.MULKEYINC.COM

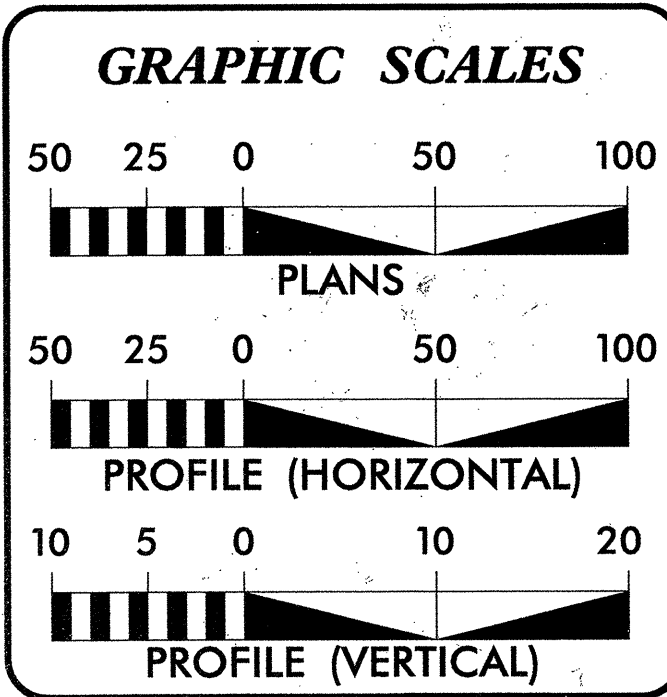

**DESIGN DATA**

ADT 2008 =	8,900
ADT 2030 =	19,500
DHV =	10 %
D =	75 %
T =	6 %*
V =	60 MPH
* TTST 1% DUAL 5%	
Func. Classification -	Major-Rural Collector

**PROJECT LENGTH**

LENGTH ROADWAY TIP PROJECT B-4300	=	.148 MILES
LENGTH STRUCTURE TIP PROJECT B-4300	=	.004 MILES
TOTAL LENGTH TIP PROJECT B-4300	=	.152 MILES

Prepared In the Office of:

**MULKEY**  
ENGINEERS & CONSULTANTS  
FOR THE NORTH CAROLINA DEPT. OF TRANSPORTATION  
2006 STANDARD SPECIFICATIONS

RIGHT OF WAY DATE:  
AUGUST 17, 2007

LETTING DATE:  
AUGUST 19, 2008

TIM JORDAN, PE  
ROADWAY PROJECT ENGINEER

JEFF RECK, PE  
HYDRAULIC PROJECT ENGINEER

DOUG TAYLOR, PE  
NCDOT ROADWAY DESIGN PROJECT ENGINEER

HYDRAULICS ENGINEER

Professional Engineer Seal: JEFFREY L. RECK, No. 026896

SIGNATURE: JEFFREY L. RECK, 5/24/08 P.E.

Professional Engineer Seal: DOUG TAYLOR, No. 21102

SIGNATURE: DOUG TAYLOR, 6/3/08 P.E.

DIVISION OF HIGHWAYS  
STATE OF NORTH CAROLINA

Professional Engineer Seal: State of North Carolina, Department of Transportation

SIGNATURE: Art McMillan, P.E.

STATE HIGHWAY DESIGN ENGINEER

5/22/2008 10:10:56 AM R:\Projects\N4300-Fdy-fsh.dgn

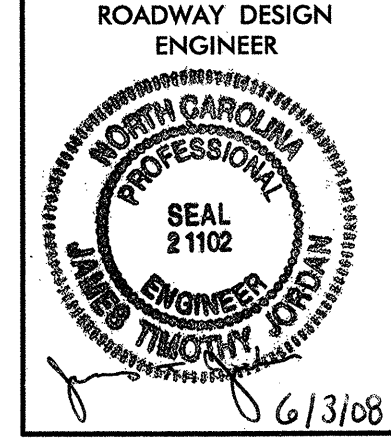

Sheet #	Description	2006 ROADWAY ENGLISH STANDARD DRAWINGS	EFF. 07-18-06 REV. 01-02-07
1	Title Sheet	The following Roadway Standards as appear in "Roadway Standard Drawings" Highway Design Branch - N. C. Department of Transportation - Raleigh, N. C., Dated July 18, 2006 are applicable to this project and by reference hereby are considered a part of these plans:	
1-A	Index of Sheets, General Notes, & List of Standards		
1-B	Conventional Symbols		
1-C	Survey Control Sheet		
2	Pavement Schedule, Wedging Detail & Typical Sections	<b>STD.NO. TITLE</b> <b>DIVISION 2 - EARTHWORK</b> 200.03 Method of Clearing - Method III 225.02 Guide for Grading Subgrade - Secondary and Local 225.04 Method of Obtaining Superelevation - Two Lane Pavement	
2-A	Typical Sections		
2-B	Detour		
2-C	Rock Plating Detail & TEMPORARY HEADWALL DETAIL	<b>DIVISION 3 - PIPE CULVERTS</b> 300.01 Method of Pipe Installation - Method 'A' 310.10 Driveway Pipe Construction	
3	Summary of Quantities		
3-A	List of Pipe, Endwalls, Etc. (For Pipe 48" & Under) & (For Pipe 54" & Over)	<b>DIVISION 5 - SUBGRADE, BASES AND SHOULDERS</b> 560.01 Method of Shoulder Construction - High Side of Superelevated Curve - Method I	
3-B	Summary of Earthwork, Summary of Pavement Removal, Guardrail Summary & Temporary Guardrail Summary		
4	Plan	<b>DIVISION 8 - INCIDENTALS</b> 806.01 Concrete Right-of-Way Marker 806.02 Granite Right-of-Way Marker 815.03 Pipe Underdrain and Blind Drain 816.04 Markers for Drainage Structure and Concrete Pad 838.21 Reinforced Concrete Endwall - for Single 54" Pipe 90 Skew 838.45 Notes for Reinforced Concrete Endwall - Std. Dwg 838.21 thru 838.40 838.51 Reinforced Brick Endwall - for Single 54" Pipe 90 Skew 838.75 Notes for Reinforced Brick Endwall - Std. Dwg 838.51 thru 838.70 838.80 Precast Endwalls - 12" thru 72" Pipe 90 Skew 862.01 Guardrail Placement 862.02 Guardrail Installation 862.03 Structure Anchor Units 876.04 Drainage Ditches with Class 'B' Rip Rap 876.01 Rip Rap in Channels	
5	Profile		
TCP-1 thru TCP-7	Traffic Control Plans		
EC-1 thru EC-7	Erosion Control Plans		
RF-1	Refrestation Detail Sheet		
UO-1 thru UO-2	Utilities by Others Plans		
X-1	Cross Section Summary Sheet		
X-2 thru X-5	Cross-Sections		
C-1 thru C-5	Culvert Plans		

**General Notes:**

**2006 Specifications**  
Effective: 07-18-06  
Revised: 07-18-06

**Grading and Surfacing or Resurfacing and Widening:**  
The grade lines shown denote the finished elevation of the proposed surfacing at grade points shown on the typical sections. Where no grade lines are shown, the profiles shown denote the top elevation of the existing pavement along the center line of survey on which the proposed resurfacing will be placed. Grade lines may be adjusted by the engineer in order to secure a proper tie-in.

**Clearing:**  
Clearing on this project shall be performed to the limits established by method III.

**Superelevation:**  
Sill curves on this project shall be superelevated in accordance with Std. no. 225.04 using the rate of superelevation and runoff shown on the plans. Superelevation is to be revolved about the grade points shown on the typical sections.

**Shoulder Construction:**  
Asphalt, earth, and concrete shoulder construction on the high side of superelevated curves shall be in accordance with Std. no. 560.01.

**Side Roads:**  
The contractor will be required to do all necessary work to provide suitable connections with all roads, streets, and drives entering this project. This work will be paid for at the contract unit price for the particular items involved.

**Underdrains:**  
Underdrains shall be constructed in accordance with Std. no. 815.03 at locations directed by the engineer.

**Guardrail:**  
The guardrail locations shown on the plans may be adjusted during construction as directed by the engineer. The contractor should consult with the engineer prior to ordering guardrail material.

**Temporary Shoring:**  
Shoring required for the maintenance of traffic will be paid for as "Extra work" in accordance with section 104-7.

**Subsurface Plans:**  
No subsurface plans are available on this project. The contractor should make his own investigation as to the subsurface conditions.

**Utilities:**  
Utility owners on this project are Bell South, Progress Energy, AT&T, and Time Warner Cable.  
  
Any relocation of existing utilities will be accomplished by others.

**Right-of-Way Markers:**  
All right-of-way markers on this project shall be placed by contract.

8/17/99

5/29/2008  
B:\Roadway\Proj\B4300\_rdy\_tsh.dgn  
3:08:05 PM















Note: Not to Scale

\*S.U.E. = Subsurface Utility Engineering











STATE OF NORTH CAROLINA  
DIVISION OF HIGHWAYS

# CONVENTIONAL PLAN SHEET SYMBOLS









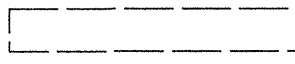

### BOUNDARIES AND PROPERTY:

State Line	_____
County Line	_____
Township Line	_____
City Line	_____
Reservation Line	_____
Property Line	_____
Existing Iron Pin	_____ 
Property Corner	_____ 
Property Monument	_____ 
Parcel/Sequence Number	_____ 
Existing Fence Line	_____ 
Proposed Woven Wire Fence	_____ 
Proposed Chain Link Fence	_____ 
Proposed Barbed Wire Fence	_____ 
Existing Wetland Boundary	_____ 
Proposed Wetland Boundary	_____ 
Existing Endangered Animal Boundary	_____ 
Existing Endangered Plant Boundary	_____ 





### BUILDINGS AND OTHER CULTURE:

Gas Pump Vent or U/G Tank Cap	_____ 
Sign	_____ 
Well	_____ 
Small Mine	_____ 
Foundation	_____ 
Area Outline	_____ 
Cemetery	_____ 
Building	_____ 
School	_____ 
Church	_____ 
Dam	_____ 





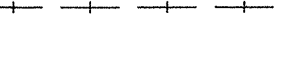







### HYDROLOGY:

Stream or Body of Water	_____
Hydro, Pool or Reservoir	_____ 
Jurisdictional Stream	_____ 
Buffer Zone 1	_____ 
Buffer Zone 2	_____ 
Flow Arrow	_____ 
Disappearing Stream	_____ 
Spring	_____ 
Wetland	_____ 
Proposed Lateral, Tail, Head Ditch	_____ 
False Sump	_____ 











### RAILROADS:

Standard Gauge	_____ 
RR Signal Milepost	_____ 
Switch	_____ 
RR Abandoned	_____ 
RR Dismantled	_____ 







### RIGHT OF WAY:

Baseline Control Point	_____ 
Existing Right of Way Marker	_____ 
Existing Right of Way Line	_____ 
Proposed Right of Way Line	_____ 
Proposed Right of Way Line with Iron Pin and Cap Marker	_____ 
Proposed Right of Way Line with Concrete or Granite Marker	_____ 
Existing Control of Access	_____ 
Proposed Control of Access	_____ 
Existing Easement Line	_____ 
Proposed Temporary Construction Easement	_____ 
Proposed Temporary Drainage Easement	_____ 
Proposed Permanent Drainage Easement	_____ 
Proposed Permanent Utility Easement	_____ 





### ROADS AND RELATED FEATURES:

Existing Edge of Pavement	_____
Existing Curb	_____
Proposed Slope Stakes Cut	_____ 
Proposed Slope Stakes Fill	_____ 
Proposed Wheel Chair Ramp	_____ 
Proposed Wheel Chair Ramp Curb Cut	_____ 
Curb Cut for Future Wheel Chair Ramp	_____ 
Existing Metal Guardrail	_____ 
Proposed Guardrail	_____ 
Existing Cable Guiderail	_____ 
Proposed Cable Guiderail	_____ 
Equality Symbol	_____ 
Pavement Removal	_____ 





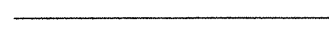
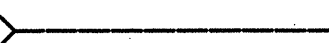
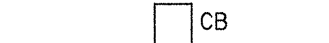

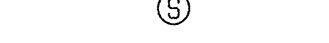
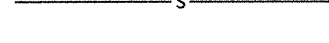



### VEGETATION:

Single Tree	_____ 
Single Shrub	_____ 
Hedge	_____ 
Woods Line	_____ 
Orchard	_____ 
Vineyard	_____ 













### EXISTING STRUCTURES:

MAJOR:	
Bridge, Tunnel or Box Culvert	_____ 
Bridge Wing Wall, Head Wall and End Wall	_____ 
MINOR:	
Head and End Wall	_____ 
Pipe Culvert	_____ 
Footbridge	_____ 
Drainage Box: Catch Basin, DI or JB	_____ 
Paved Ditch Gutter	_____ 
Storm Sewer Manhole	_____ 
Storm Sewer	_____ 







### UTILITIES:

POWER:	
Existing Power Pole	_____ 
Proposed Power Pole	_____ 
Existing Joint Use Pole	_____ 
Proposed Joint Use Pole	_____ 
Power Manhole	_____ 
Power Line Tower	_____ 
Power Transformer	_____ 
U/G Power Cable Hand Hole	_____ 
H-Frame Pole	_____ 
Recorded U/G Power Line	_____ 
Designated U/G Power Line (S.U.E.*)	_____ 

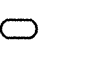



### TELEPHONE:

Existing Telephone Pole	_____ 
Proposed Telephone Pole	_____ 
Telephone Manhole	_____ 
Telephone Booth	_____ 
Telephone Pedestal	_____ 
Telephone Cell Tower	_____ 
U/G Telephone Cable Hand Hole	_____ 
Recorded U/G Telephone Cable	_____ 
Designated U/G Telephone Cable (S.U.E.*)	_____ 
Recorded U/G Telephone Conduit	_____ 
Designated U/G Telephone Conduit (S.U.E.*)	_____ 
Recorded U/G Fiber Optics Cable	_____ 
Designated U/G Fiber Optics Cable (S.U.E.*)	_____ 

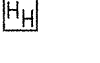
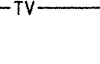
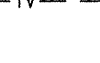

### WATER:

Water Manhole	_____ 
Water Meter	_____ 
Water Valve	_____ 
Water Hydrant	_____ 
Recorded U/G Water Line	_____ 
Designated U/G Water Line (S.U.E.*)	_____ 
Above Ground Water Line	_____ 



### TV:

TV Satellite Dish	_____ 
TV Pedestal	_____ 
TV Tower	_____ 
U/G TV Cable Hand Hole	_____ 
Recorded U/G TV Cable	_____ 
Designated U/G TV Cable (S.U.E.*)	_____ 
Recorded U/G Fiber Optic Cable	_____ 
Designated U/G Fiber Optic Cable (S.U.E.*)	_____ 

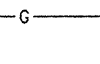
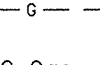
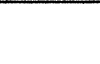



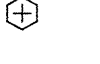
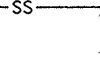
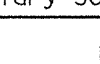

### GAS:

Gas Valve	_____ 
Gas Meter	_____ 
Recorded U/G Gas Line	_____ 
Designated U/G Gas Line (S.U.E.*)	_____ 
Above Ground Gas Line	_____ 

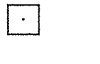
### SANITARY SEWER:

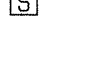
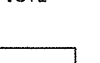
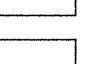
Sanitary Sewer Manhole	_____ 
Sanitary Sewer Cleanout	_____ 
U/G Sanitary Sewer Line	_____ 
Above Ground Sanitary Sewer	_____ 
Recorded SS Forced Main Line	_____ 
Designated SS Forced Main Line (S.U.E.*)	_____ 

### MISCELLANEOUS:

Utility Pole	_____ 
Utility Pole with Base	_____ 
Utility Located Object	_____ 
Utility Traffic Signal Box	_____ 
Utility Unknown U/G Line	_____ 
U/G Tank; Water, Gas, Oil	_____ 
A/G Tank; Water, Gas, Oil	_____ 
U/G Test Hole (S.U.E.*)	_____ 
Abandoned According to Utility Records	_____ 
End of Information	_____ 

# SURVEY CONTROL SHEET B-4300

# WAKE COUNTY

LOCATION: BRIDGE NO. 29 OVER CLARKS CREEK AND APPROACHES ON SR 1007 (POOLE ROAD)

B-4300

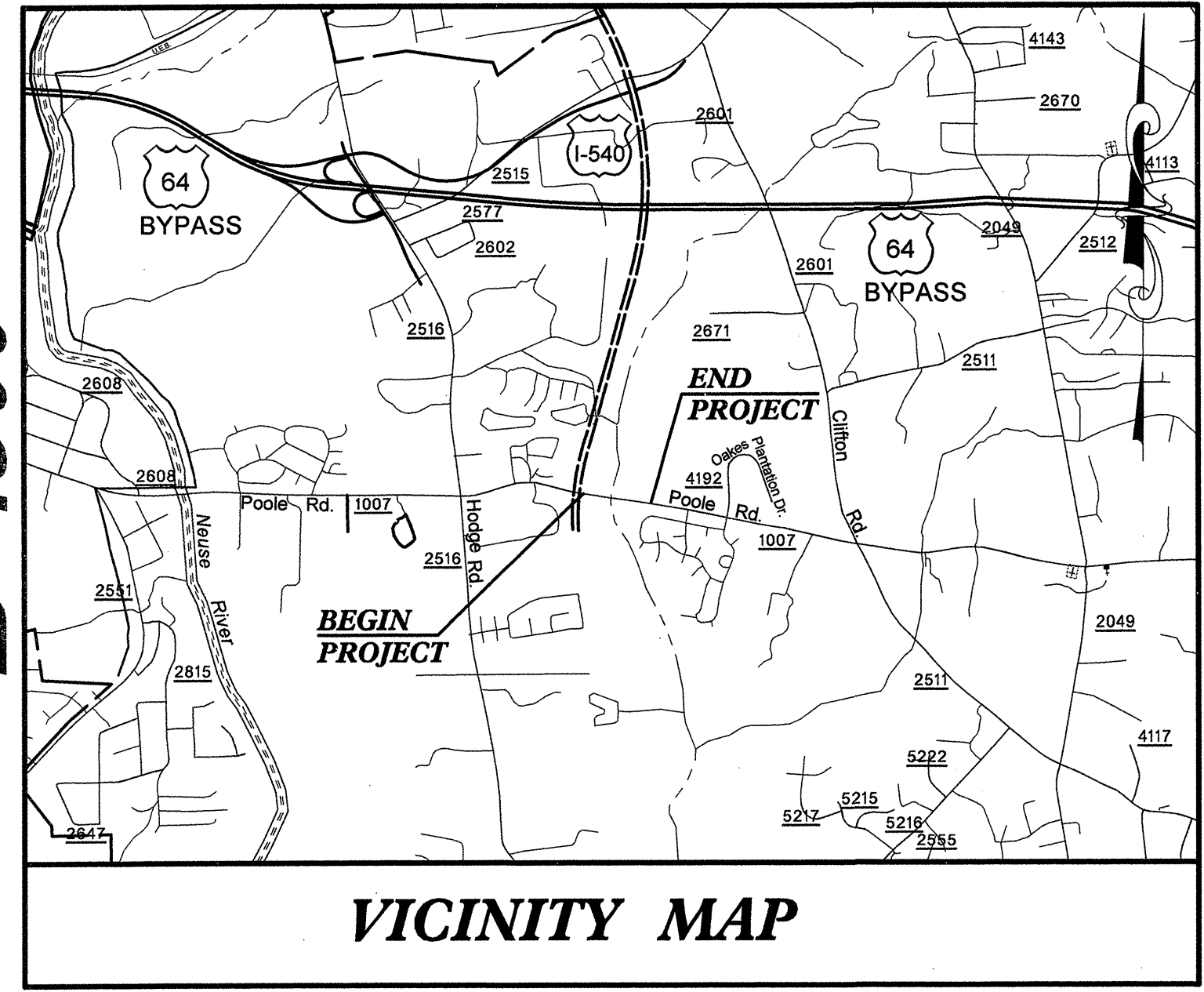

VICINITY MAP



STA. 15 + 00.00 -L- BEGIN TIP PROJECT B-4300

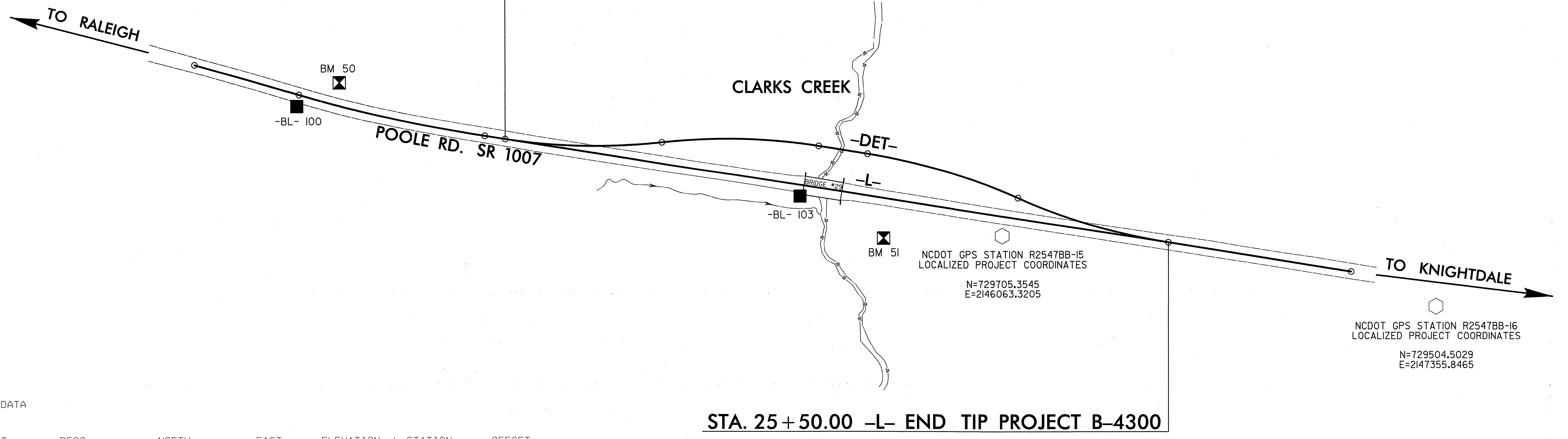

CONTROL DATA

BASELINE POINT	DESC.	NORTH	EAST	ELEVATION	L STATION	OFFSET
100	BL-100	729909.0020	2144960.0840	215.24	11+71.50	17.89 RT
103	BL-103	729767.0260	2145747.2682	197.00	19+69.72	18.32 RT
15	R2547BB-15	729705.3545	2146063.3205	203.39	22+91.50	30.45 RT
16	R2547BB-16	729504.5029	2147355.8465	252.17	OUTSIDE PROJECT LIMITS	

BENCHMARK DATA

\*\*\*\*\*  
 BM 50 ELEVATION = 220.04  
 N 729946 E 2145027  
 L STATION 12+26 35 LEFT  
 R/R SPIKE IN 8 INCH WALNUT  
 \*\*\*\*\*  
 BM 51 ELEVATION = 195.14  
 N 729701 E 2145877  
 L STATION 21+08 63 RIGHT  
 R/R SPIKE IN 16 INCH PIN OAK  
 \*\*\*\*\*

### DATUM DESCRIPTION

THE LOCALIZED COORDINATE SYSTEM DEVELOPED FOR THIS PROJECT IS BASED ON THE STATE PLANE COORDINATES ESTABLISHED BY NCGS FOR MONUMENT "WELL" WITH NAD 1983 STATE PLANE GRID COORDINATES OF NORTHING: 744982.3584(fft) EASTING: 2138025.6581(fft) THE AVERAGE COMBINED GRID FACTOR USED ON THIS PROJECT (GROUND TO GRID) IS: 0.99990678 THE N.C. LAMBERT GRID BEARING AND LOCALIZED HORIZONTAL GROUND DISTANCE FROM "WELL" TO -L- STATION 15+00.00 IS S 25°38'33.0" E 16,777.06' ALL LINEAR DIMENSIONS ARE LOCALIZED HORIZONTAL DISTANCES VERTICAL DATUM USED IS NAVD 29

NOTE: DRAWING NOT TO SCALE

NOTES:

THE CONTROL DATA FOR THIS PROJECT CAN BE FOUND ELECTRONICALLY BY SELECTING PROJECT CONTROL DATA AT:  
[HTTP://WWW.DOH.DOT.STATE.NC.US/PRECONSTRUCT/HIGHWAY/LOCATION/PROJECT/](http://www.doh.dot.state.nc.us/preconstruct/highway/location/project/)  
 B4300\_ls\_control\_070130.txt

SITE CALIBRATION INFORMATION HAS NOT BEEN PROVIDED FOR THIS PROJECT. IF FURTHER INFORMATION IS NEEDED, PLEASE CONTACT THE LOCATION AND SURVEYS UNIT.  
 ○ INDICATES GEODETIC CONTROL MONUMENTS USED OR SET FOR HORIZONTAL PROJECT CONTROL BY THE NCDOT LOCATION AND SURVEYS UNIT.  
 PROJECT CONTROL ESTABLISHED USING GLOBAL POSITIONING SYSTEM.  
 NETWORK ESTABLISHED FROM EXISTING NCGS MONUMENTATION



5/14/99

**PAVEMENT SCHEDULE**  
(FINAL PAVEMENT DESIGN)

C1	PROP. APPROX. 1½" ASPHALT CONCRETE SURFACE COURSE, TYPE S9.5B, AT AN AVERAGE RATE OF 168 LBS. PER SQ. YD.
C2	PROP. APPROX. 3" ASPHALT CONCRETE SURFACE COURSE, TYPE S9.5B, AT AN AVERAGE RATE OF 168 LBS. PER SQ. YD. IN EACH OF TWO LAYERS.
C3	PROP. VAR. DEPTH ASPHALT CONCRETE SURFACE COURSE, TYPE S9.5B, AT AN AVERAGE RATE OF 112 LBS. PER SQ. YD. PER 1" DEPTH. TO BE PLACED IN LAYERS NOT LESS THAN 1½" IN DEPTH OR GREATER THAN 2" IN DEPTH.
D1	PROP. APPROX. 3" ASPHALT CONCRETE INTERMEDIATE COURSE, TYPE I19.0B, AT AN AVERAGE RATE OF 342 LBS. PER SQ. YD.
D2	PROP. VAR. DEPTH ASPHALT CONCRETE INTERMEDIATE COURSE, TYPE I19.0B, AT AN AVERAGE RATE OF 114 LBS. PER SQ. YD. PER 1" DEPTH. TO BE PLACED IN LAYERS NOT LESS THAN 2½" IN DEPTH OR GREATER THAN 4" IN DEPTH.
E1	PROP. APPROX. 4½" ASPHALT CONCRETE BASE COURSE, TYPE B25.0B, AT AN AVERAGE RATE OF 513 LBS. PER SQ. YD.
E2	PROP. APPROX. 5½" ASPHALT CONCRETE BASE COURSE, TYPE B25.0B, AT AN AVERAGE RATE OF 627 LBS. PER SQ. YD.
E3	PROP. VAR. DEPTH ASPHALT CONCRETE BASE COURSE, TYPE B25.0B, AT AN AVERAGE RATE OF 114 LBS. PER SQ. YD. PER 1" DEPTH. TO BE PLACED IN LAYERS NOT LESS THAN 3" IN DEPTH OR GREATER THAN 5½" IN DEPTH.
T	EARTH MATERIAL.
U	EXISTING PAVEMENT.
W	VARIABLE DEPTH ASPHALT PAVEMENT (SEE STANDARD WEDGING DETAIL)

NOTE: PAVEMENT EDGE SLOPES ARE 1:1 UNLESS SHOWN OTHERWISE.

**MULKEY**  
ENGINEERS & CONSULTANTS  
PO BOX 33157  
RALEIGH, N.C. 27636  
(919) 851-1918  
(919) 851-1918 (FAX)  
WWW.MULKEYINC.COM

PROJECT REFERENCE NO. B-4300	SHEET NO. 2
RW SHEET NO.	
ROADWAY DESIGN ENGINEER	PAVEMENT DESIGN ENGINEER

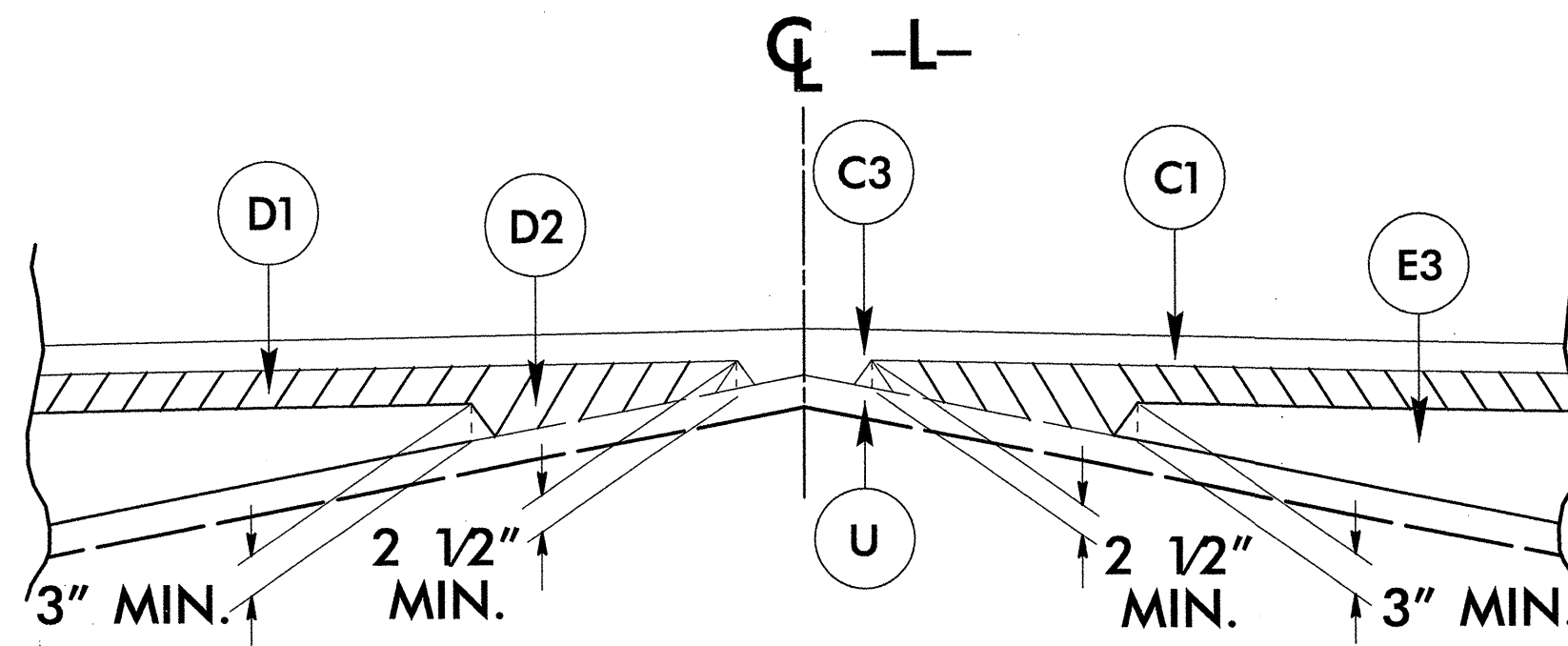

**DETAIL SHOWING METHOD OF WEDGING**

USE IN CONJUNCTION WITH TYPICAL SECTION NO. 1

NOTE: AFTER DETOUR REMOVAL, OVERLAY EXISTING PAVEMENT WITH C1 FROM

- L- STA. 15+00.00 TO STA. 17+50.00
- L- STA. 24+50.00 TO STA. 25+50.00

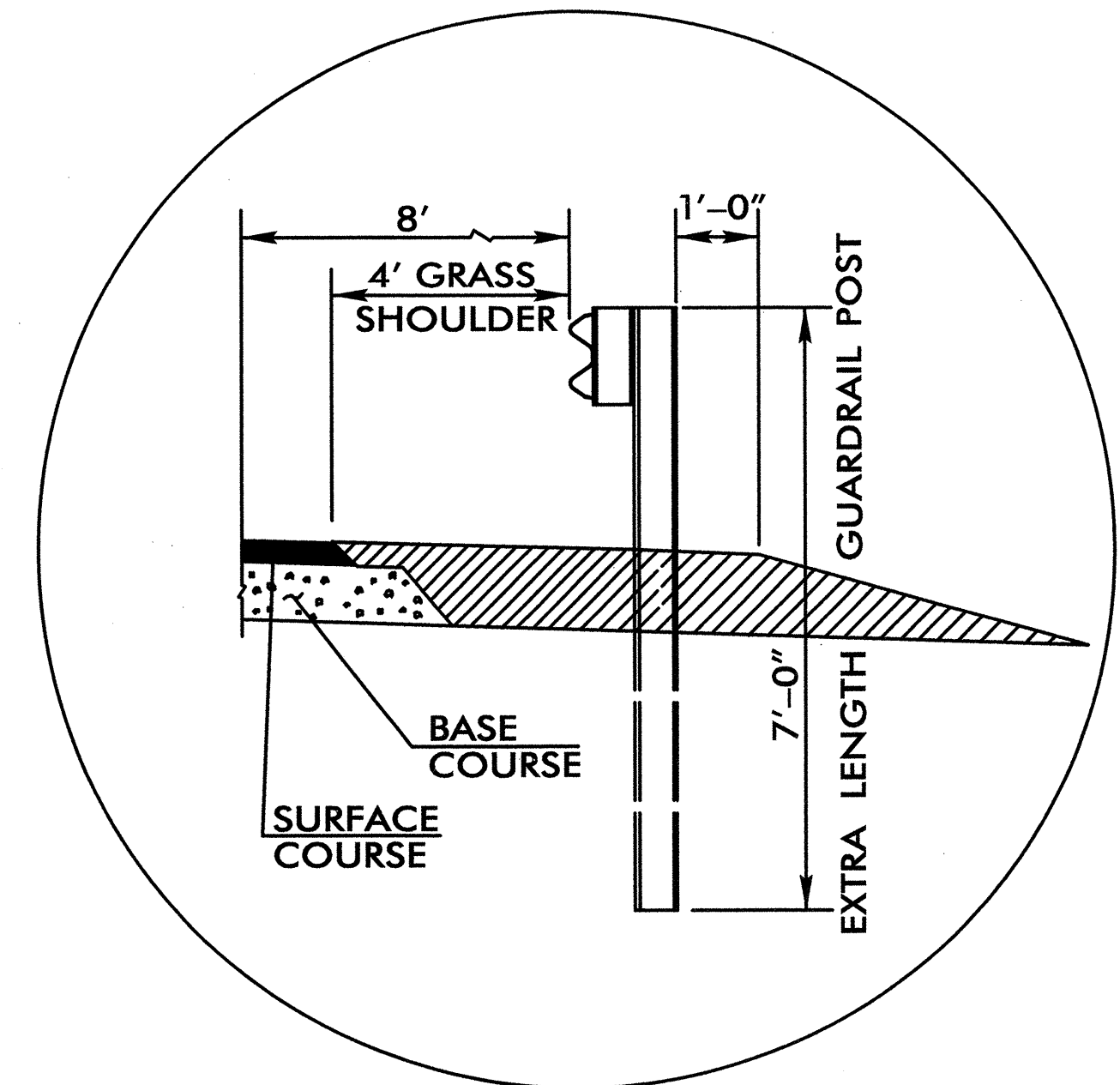

USE IN CONJUNCTION WITH TYPICAL SECTION NOS. 1 & 2.

- L- STA. 19+25+/- TO STA. 19+94+/- RT

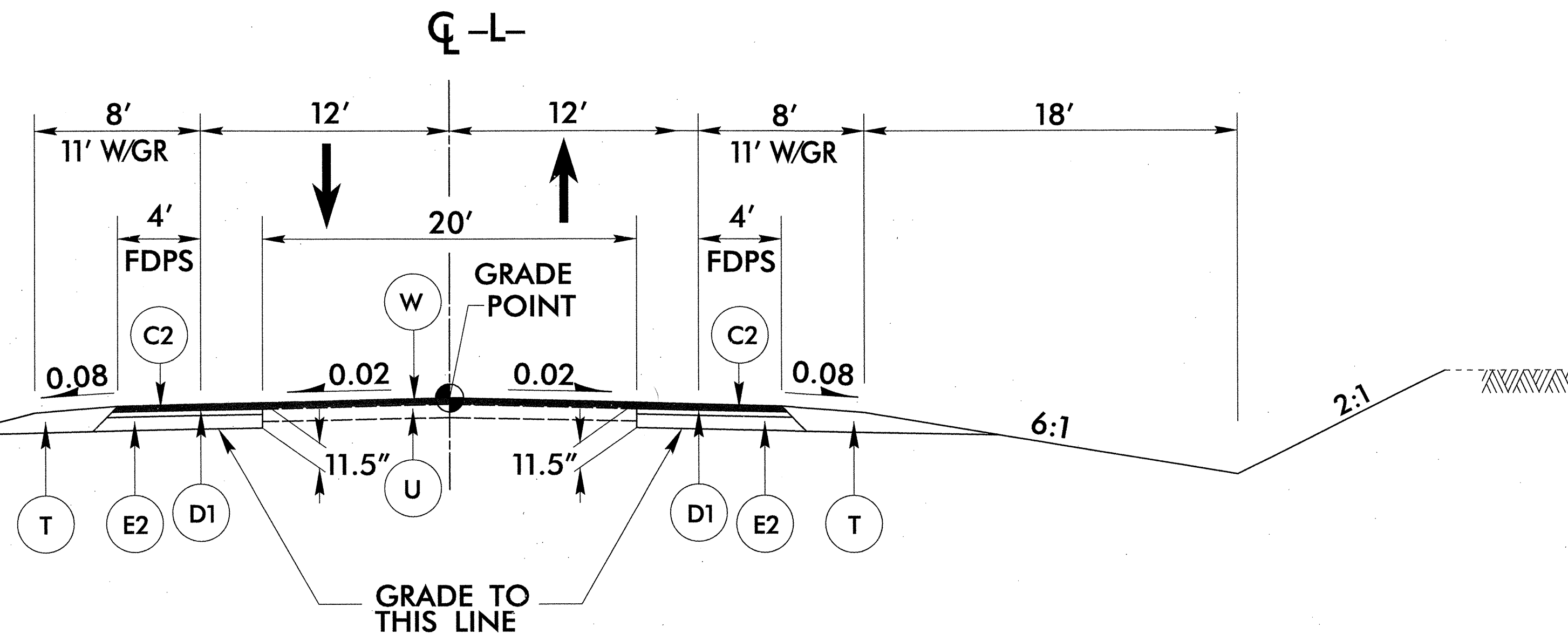

**TYPICAL SECTION NO. 1**

USE TYPICAL SECTION NO. 1 AT THE FOLLOWING LOCATIONS

- TRANSITION FROM EXISTING TO T.S. NO. 1 FROM
- L- STA. 17+00.00 TO STA. 17+50.00
- L- STA. 17+50.00 TO STA. 19+60.00
- L- STA. 23+75.00 TO STA. 24+50.00
- TRANSITION FROM T.S. NO. 1 TO EXISTING
- L- STA. 24+50.00 TO STA. 25+00.00

5/28/2008  
R:\Roadway\Proj\B4300\_rdy\_typ.dgn  
3:23:01 PM

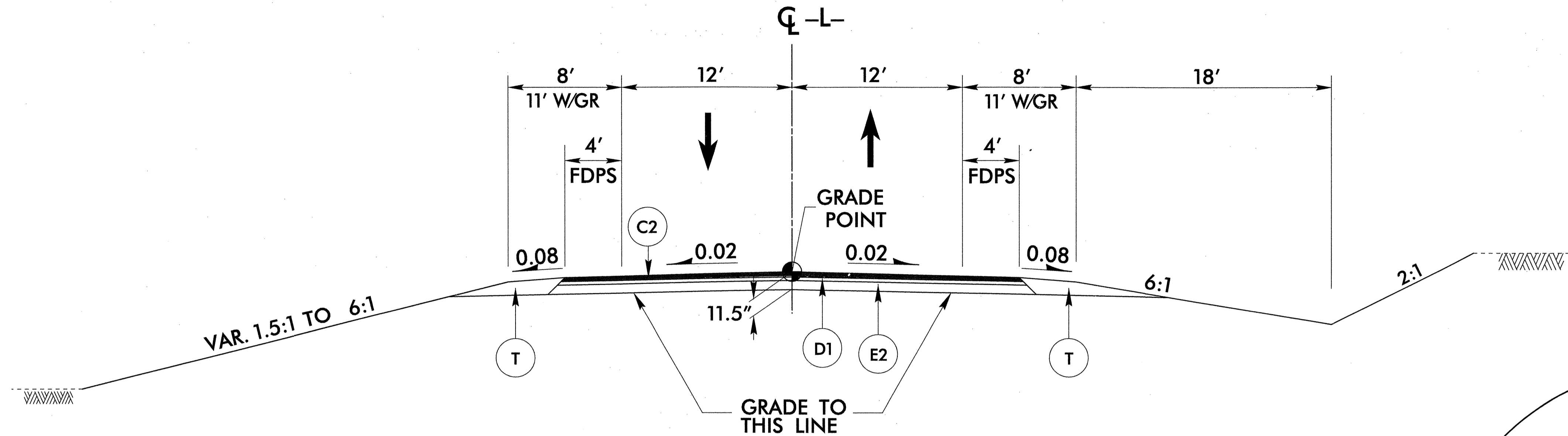

**TYPICAL SECTION NO. 2**

USE TYPICAL SECTION NO. 2  
AT THE FOLLOWING LOCATIONS  
-L- STA. 19+60.00 TO STA. 23+75.00

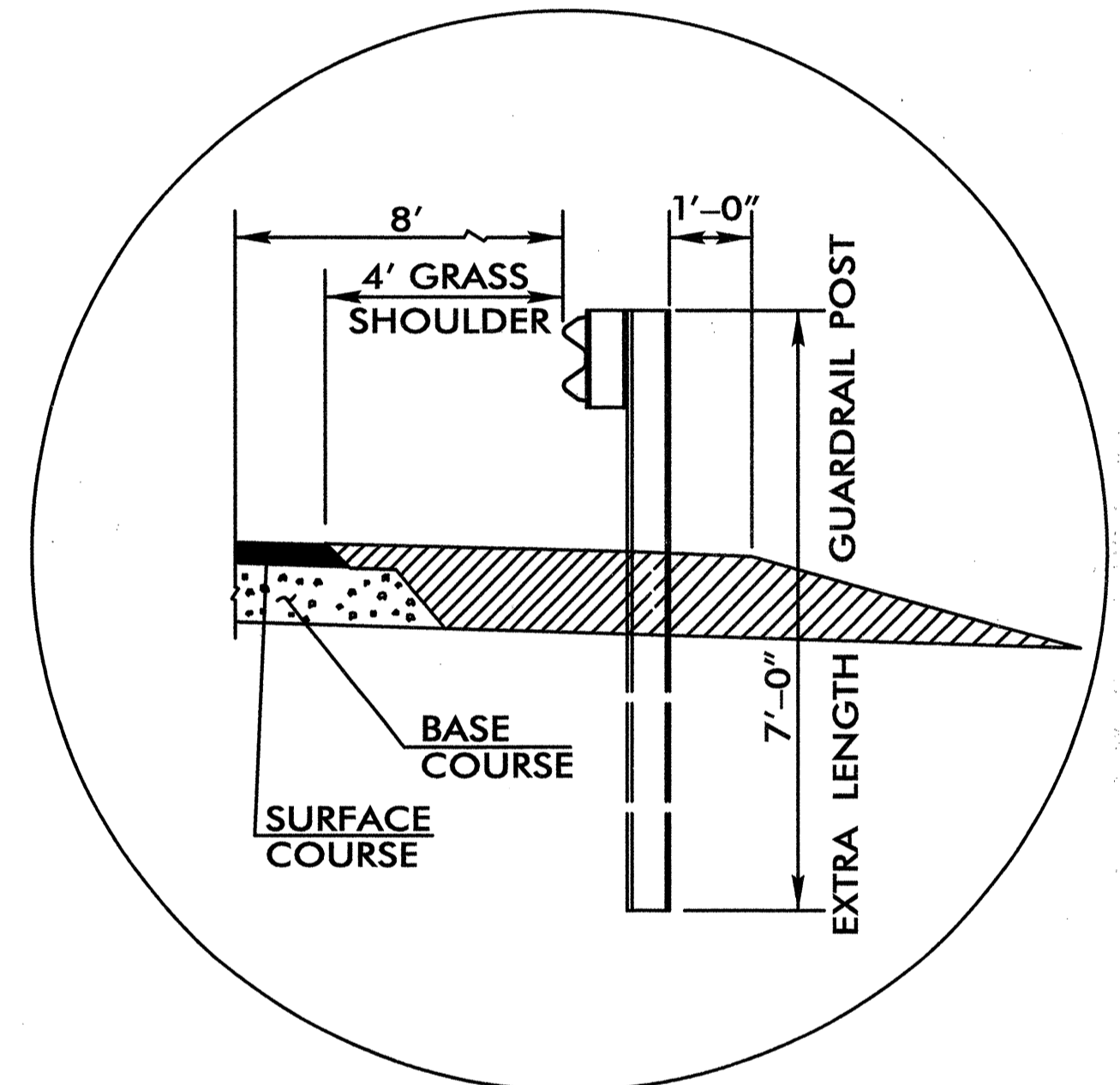

USE IN CONJUNCTION WITH TYPICAL SECTION NOS. 1 & 2.  
-L- STA. 19+25+/- TO STA. 19+94+/- RT

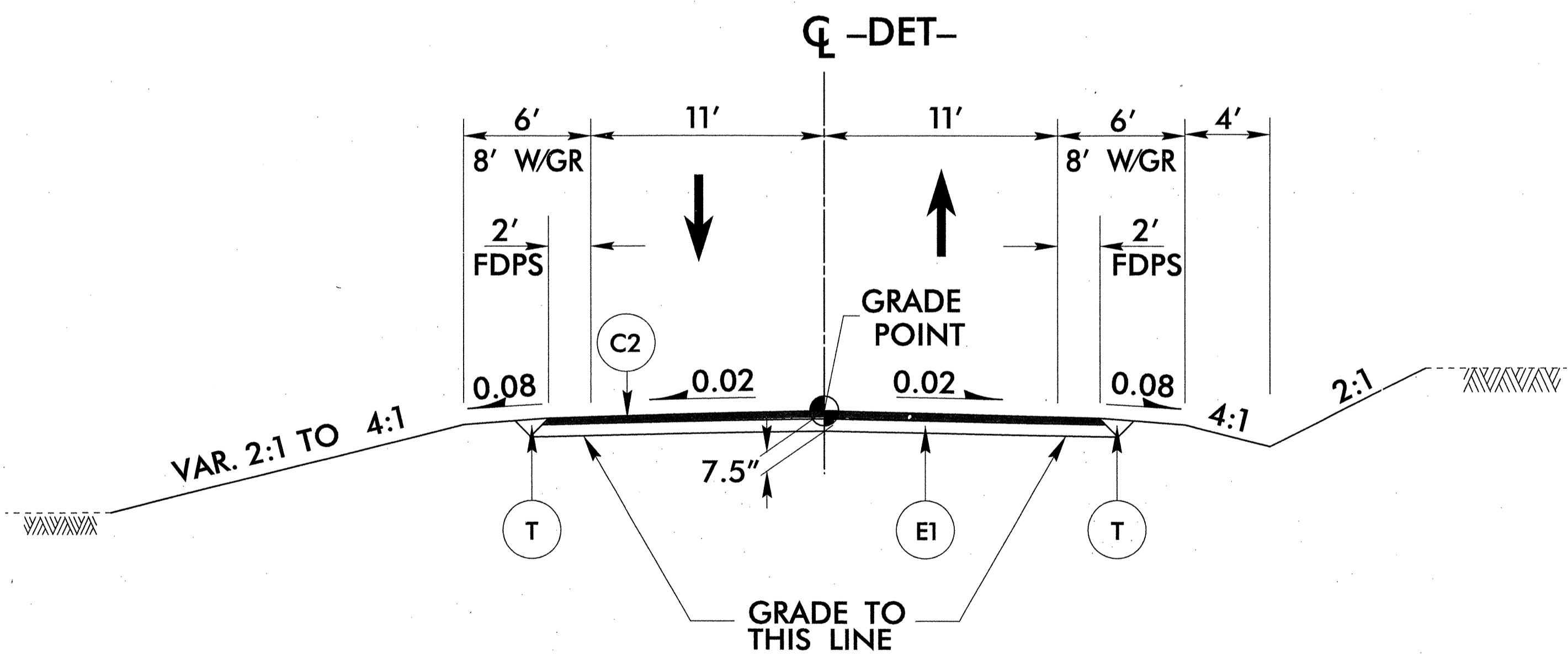

**TYPICAL SECTION NO. 3**

USE TYPICAL SECTION NO. 3  
AT THE FOLLOWING LOCATIONS  
-DET- STA. 16+39.53 TO STA. 24+25.34

PAVEMENT SCHEDULE (FINAL PAVEMENT DESIGN)	
C2	3" S9.5B
D1	3" I19.0B
E1	4½" B25.0B
E2	5½" B25.0B
T	EARTH MATERIAL





# TEMPORARY HEADWALL

<b>PROJECT REFERENCE NO.</b> B-4300	<b>SHEET</b> 2-C
GEOTECHNICAL ENGINEER	ENGINEER
	
DATE: 6/19/08	SIGNATURE: _____ DATE: _____

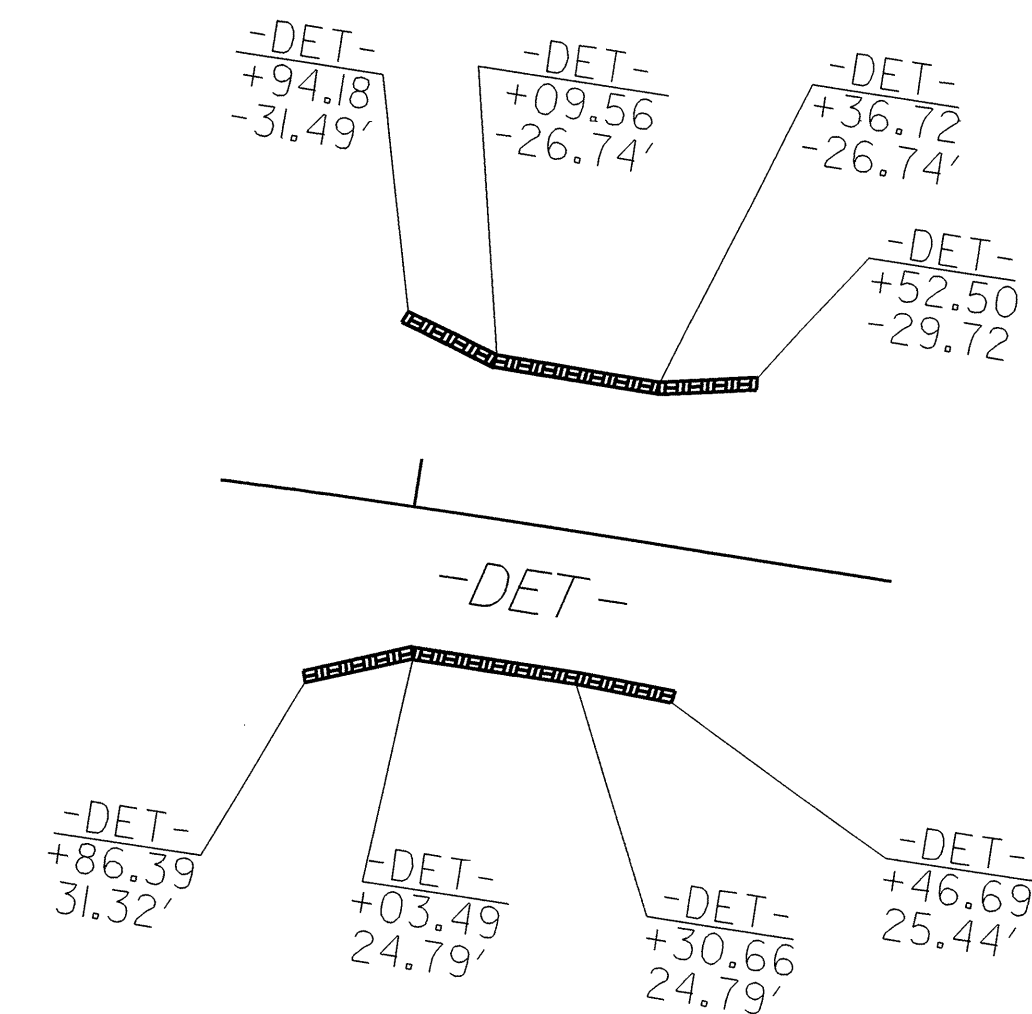

TEMPORARY HEADWALL LOCATION SKETCH

TEMPORARY HEADWALL ENVELOPE					
EL.	200	200	200	200	200
EL.	190	190	190	190	190
EL.	180	180	180	180	180
EL.	170	170	170	170	170
STA.	20+00	21+00	20+00	21+00	
	-WALL LT-		-WALL RT-		

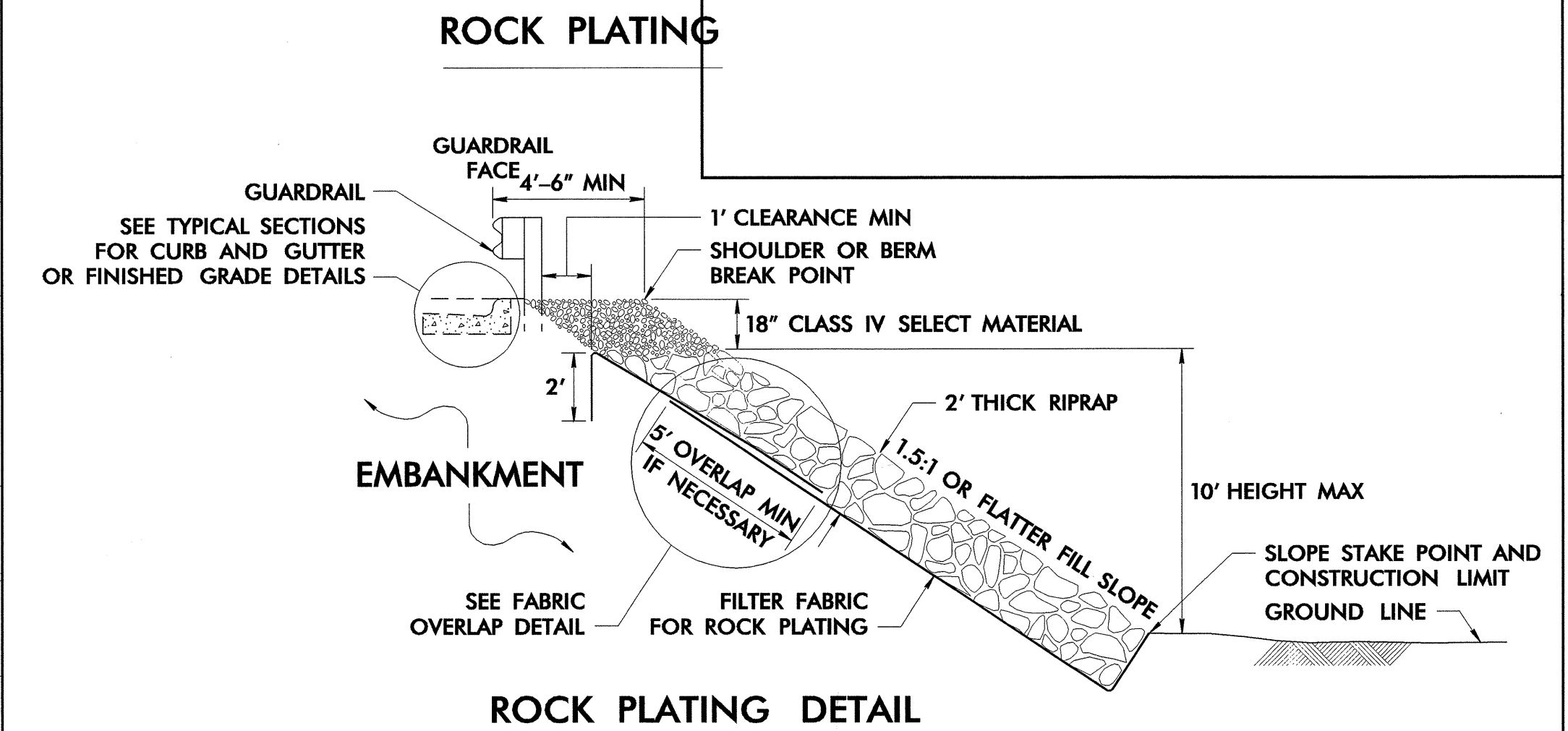

- FOR THE DESIGN OF THE TEMPORARY HEADWALL NOTED IN THE PLANS, USE CONTRACTOR DESIGNED TEMPORARY SHORING IN ACCORDANCE WITH THE TEMPORARY SHORING SPECIAL PROVISION.
- BEFORE BEGINNING TEMPORARY HEADWALL DESIGN, SURVEY ALL EXISTING GROUND ELEVATIONS SHOWN ON THE PLANS AND SUBMIT A REVISED HEADWALL ENVELOPE. DO NOT BEGIN TEMPORARY HEADWALL DESIGN OR CONSTRUCTION UNTIL THIS ENVELOPE HAS BEEN APPROVED.
- FOR CONTRACTOR DESIGNED TEMPORARY HEADWALL FROM STA. 19+94.18 -DET-, 31.49 FT. LT. TO STA. 20+52.50 -DET-, 29.72 FT. LT., AND FROM STA. 19+86.39 -DET-, 31.32 FT. RT., TO STA. 20+46.69 -DET-, 25.44 FT. RT., DESIGN TEMPORARY HEADWALL/ TEMPORARY SHORING FOR THE FOLLOWING IN-SITU ASSUMED SOIL PARAMETERS:  
 UNIT WEIGHT OF SOIL ABOVE WATER TABLE = 120 PCF  
 UNIT WEIGHT OF SOIL BELOW WATER TABLE = 60 PCF  
 FRICTION ANGLE = 30 DEGREES  
 COHESION = 0 PSF
- THE FACE OF THE TEMPORARY HEADWALL SHOULD BE LOCATED A MINIMUM OF ONE FOOT FROM THE END OF THE PIPE AND THE TOE OF THE FILL SLOPE SHOULD BE LOCATED TWO FEET FROM THE FACE OF THE TEMPORARY HEADWALL.
- SAND BAGS MAY BE USED AS WALL FORMS FOR AN APPROVED TEMPORARY MSE HEADWALL IN ACCORDANCE WITH THE TEMPORARY SHORING SPECIAL PROVISION TO RETAIN FILL PLACED BEHIND THE SAND BAGS.
- DESIGN AND SUBMIT FOR REVIEW A FABRIC DETAIL TO RETAIN EMBANKMENT FILL MATERIAL PLACED OVER THE FULL LENGTH OF THE 84 INCH DIAMETER STEEL PIPES SUCH THAT EMBANKMENT FILL MATERIAL WILL NOT SETTLE BETWEEN THE PIPES. REINFORCING FABRIC SHOULD MEET THE REQUIREMENTS FOR REINFORCING FABRIC IN THE TEMPORARY SHORING SPECIAL PROVISION AND HAVE ADEQUATE STRENGTH TO RETAIN FILL AND CARRY THE EMBANKMENT LOAD.
- USE FOUNDATION CONDITIONING MATERIAL BENEATH THE 84 INCH DIAMETER STEEL PIPES TO PROVIDE SUPPORT TO CARRY THE EMBANKMENT AND TRAFFIC LOADS ACTING ON THE PIPES.

TEMPORARY HEADWALL ENVELOPE				
-DET- STA.	OFFSET FROM C	ELEV. @ TOP OF WALL	ELEV. @ BOTTOM OF WALL	WALL HEIGHT
19+94.18	31.49' LT	194.09'	192.09'	2.00'
20+09.56	26.74' LT	195.30'	186.30'	9.00'
20+36.72	26.74' LT	195.30'	186.30	9.00'
20+52.50	29.72' LT	194.83'	192.83'	2.00'
19+86.39	31.32' RT	194.09'	192.09'	2.00'
20+03.49	24.79' RT	194.77'	185.77'	9.00'
20+30.66	24.79' RT	194.77'	185.77'	9.00'
20+46.69	25.44' RT	194.61'	192.61'	2.00'

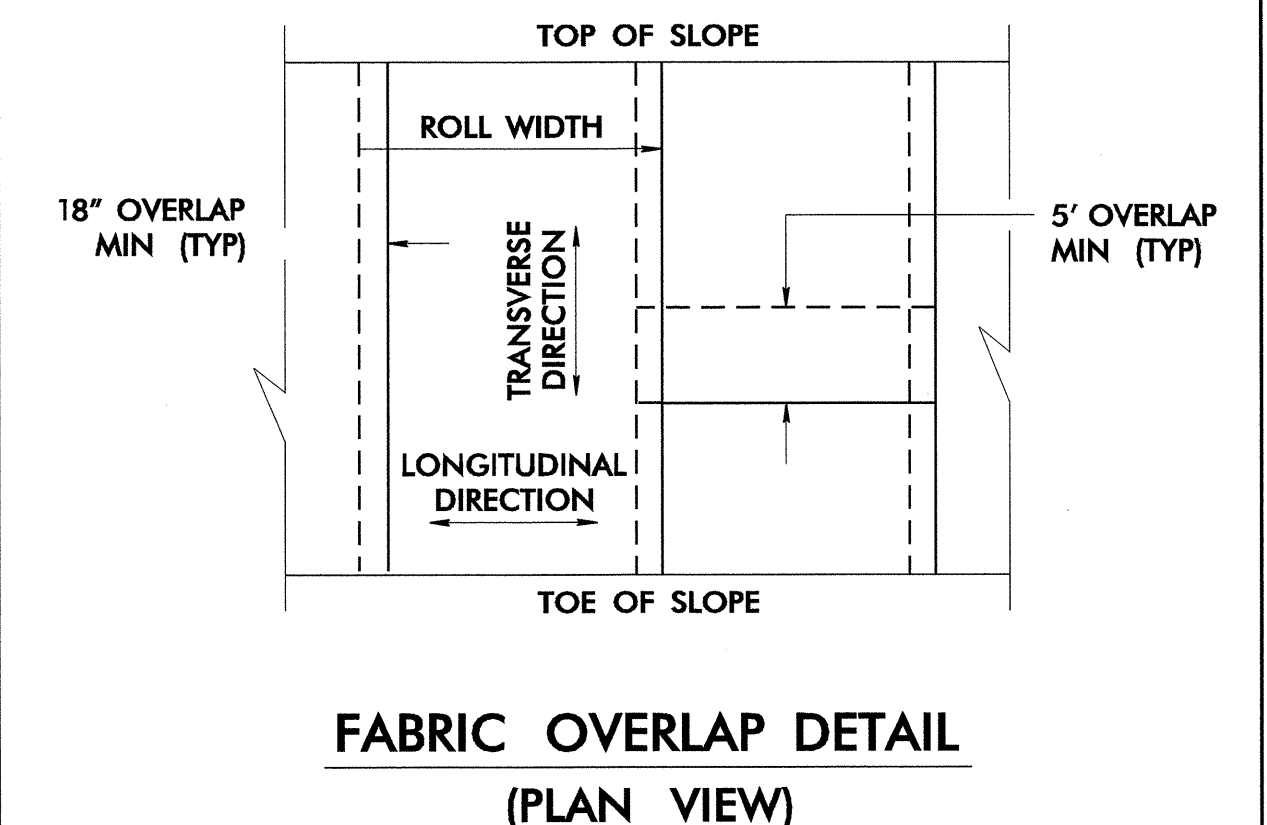

- FOR ROCK PLATING, SEE ROCK PLATING SPECIAL PROVISION.
- USE ROCK PLATING FROM STATION 18+50 -L- TO STATION 20+50 -L- (RIGHT), AND FROM STATION 19+50 -L- TO STATION 20+50 -L- (LEFT). SEE ROCK PLATING DETAIL.

ESTIMATED ROCK PLATING QUANTITIES:  
250 SQUARE YARD

ESTIMATED TEMPORARY HEADWALL QUANTITIES:

TEMPORARY HEADWALL, LEFT 300 SQ. FT.  
TEMPORARY HEADWALL, RIGHT 310 SQ. FT.

PREPARED BY: T. T. ZAN DATE: 06/2008  
REVIEWED BY: J. R. BATTS DATE: 06/2008

**GEOTECHNICAL ENGINEERING UNIT**  
 EASTERN REGIONAL OFFICE  
 WESTERN REGIONAL OFFICE

STATE OF NORTH CAROLINA  
DEPARTMENT OF TRANSPORTATION  
RALEIGH

## ROCK PLATING & TEMPORARY HEADWALL

REVISIONS					
NO.	BY	DATE	NO.	BY	DATE
1			3		
2			4		



5/28/99

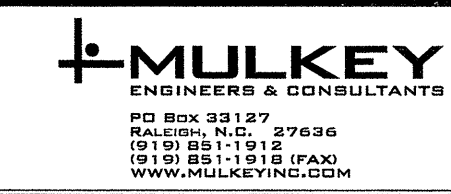

STATE OF NORTH CAROLINA  
DIVISION OF HIGHWAYS

STATE OF NORTH CAROLINA  
DIVISION OF HIGHWAYS  
ROADWAY SUMMARY OF QUANTITIES FOR CONTRACT - C201897

ItemNumber	Sec #	Quantity	Unit	Description
0000100000-N	800	Lump Sum		MOBILIZATION
0043000000-N	226	Lump Sum		GRADING
0050000000-E	226	1	ACR	SUPPLEMENTARY CLEARING & GRUB-BING
0057000000-E	226	100	CY	UNDERCUT EXCAVATION
0134000000-E	240	1,235	CY	DRAINAGE DITCH EXCAVATION
0195000000-E	265	200	CY	SELECT GRANULAR MATERIAL
0196000000-E	270	200	SY	FABRIC FOR SOIL STABILIZATION
0199000000-E	SP	610	SF	TEMPORARY SHORING
0241000000-E	SP	250	SY	GENERIC GRADING ITEM ROCK PLATING
0318000000-E	300	40	TON	FOUNDATION CONDITIONING MATERIAL, MINOR STRS
0342000000-E	310	40	LF	*** SIDE DRAIN PIPE (30")
0408000000-E	310	128	LF	54" RC PIPE CULVERTS, CLASS III
0576000000-E	310	156	LF	*** CS PIPE CULVERTS, ***** THICK (84", 0.168")
0594000000-E	310	20	LF	24" CS PIPE CULVERTS, 0.064" THICK
0600000000-E	310	24	LF	30" CS PIPE CULVERTS, 0.079" THICK
0995000000-E	340	240	LF	PIPE REMOVAL
1077000000-E	SP	25	TON	#57 STONE
1220000000-E	545	100	TON	INCIDENTAL STONE BASE
1330000000-E	607	260	SY	INCIDENTAL MILLING
1489000000-E	610	1,300	TON	ASPHALT CONC BASE COURSE, TYPE B25.0B
1498000000-E	610	425	TON	ASPHALT CONC INTERMEDIATE COURSE, TYPE 119.0B
1519000000-E	610	875	TON	ASPHALT CONC SURFACE COURSE, TYPE S9.5B
1560000000-E	620	125	TON	ASPHALT BINDER FOR PLANT MIX, GRADE PG 64-22
2000000000-N	806	13	EA	RIGHT OF WAY MARKERS
2022000000-E	815	45	CY	SUBDRAIN EXCAVATION
2033000000-E	815	34	CY	SUBDRAIN FINE AGGREGATE
2044000000-E	815	200	LF	6" PERFORATED SUBDRAIN PIPE
2055000000-E	815	6	EA	6" SUBDRAIN PIPE WYES, TEES, & ELBOWS
2066000000-N	815	1	EA	CONCRETE PAD FOR SUBDRAIN PIPE OUTLET
2077000000-E	815	6	LF	6" OUTLET PIPE (SUBDRAINS)
2220000000-E	838	10.5	CY	REINFORCED ENDWALLS
3030000000-E	862	612.5	LF	STEEL BM GUARDRAIL
3150000000-N	862	5	EA	ADDITIONAL GUARDRAIL POSTS
3270000000-N	SP	4	EA	GUARDRAIL ANCHOR UNITS, TYPE 350
3380000000-E	862	300	LF	TEMPORARY STEEL BM GUARDRAIL
3389100000-N	SP	4	EA	GUARDRAIL ANCHOR UNITS, TYPE 350 TEMPORARY
3628000000-E	876	464	TON	RIP RAP, CLASS I
3649000000-E	876	718	TON	RIP RAP, CLASS B
3651000000-E	SP	80	TON	BOULDERS
3656000000-E	876	3,086	SY	FILTER FABRIC FOR DRAINAGE
4400000000-E	1110	128	SF	WORK ZONE SIGNS (STATIONARY)
4405000000-E	1110	96	SF	WORK ZONE SIGNS (PORTABLE)
4410000000-E	1110	36	SF	WORK ZONE SIGNS (BARRICADE MOUNTED)
4430000000-N	1130	40	EA	DRUMS
4445000000-E	1145	32	LF	BARRICADES (TYPE III)
4450000000-N	1150	480	HR	FLAGGER
4480000000-N	1165	1	EA	TMA
4650000000-N	1251	30	EA	TEMPORARY RAISED PAVEMENT MARKERS
4685000000-E	1205	2,200	LF	THERMOPLASTIC PAVEMENT MARKING LINES (4", 90 MILS)
4686000000-E	1205	2,200	LF	THERMOPLASTIC PAVEMENT MARKING LINES (4", 120 MILS)

ItemNumber	Sec #	Quantity	Unit	Description
4810000000-E	1205	25,200	LF	PAINT PAVEMENT MARKING LINES (4")
4850000000-E	1205	400	LF	REMOVAL OF PAVEMENT MARKING LINES (4")
4900000000-N	1251	15	EA	PERMANENT RAISED PAVEMENT MARKERS
6000000000-E	1605	1,500	LF	TEMPORARY SILT FENCE
6006000000-E	1610	150	TON	STONE FOR EROSION CONTROL, CLASS A
6009000000-E	1610	325	TON	STONE FOR EROSION CONTROL, CLASS B
6012000000-E	1610	200	TON	SEDIMENT CONTROL STONE
6015000000-E	1615	2.5	ACR	TEMPORARY MULCHING
6018000000-E	1620	100	LB	SEED FOR TEMPORARY SEEDING
6021000000-E	1620	1.5	TON	FERTILIZER FOR TEMPORARY SEEDING
6029000000-E	SP	1,200	LF	SAFETY FENCE
6030000000-E	1630	840	CY	SILT EXCAVATION
6036000000-E	1631	925	SY	MATting FOR EROSION CONTROL
6037000000-E	SP	25	SY	COIR FIBER MAT
6038000000-E	SP	850	SY	PERMANENT SOIL REINFORCEMENT MAT
6042000000-E	1632	25	LF	1/4" HARDWARE CLOTH
6045000000-E	SP	100	LF	*** TEMPORARY PIPE (15")
6045000000-E	SP	210	LF	*** TEMPORARY PIPE (18")
6070000000-N	SP	5	EA	SPECIAL STILLING BASINS
6071030000-E	SP	135	LF	COIR FIBER BAFFLES
6071050000-E	SP	3	EA	*** SKIMMER (1-1/2")
6084000000-E	1660	3.5	ACR	SEEDING & MULCHING
6087000000-E	1660	2	ACR	MOWING
6090000000-E	1661	50	LB	SEED FOR REPAIR SEEDING
6093000000-E	1661	0.25	TON	FERTILIZER FOR REPAIR SEEDING
6096000000-E	1662	75	LB	SEED FOR SUPPLEMENTAL SEEDING
6108000000-E	1665	2	TON	FERTILIZER TOPDRESSING
6111000000-E	SP	160	LF	IMPERVIOUS DIKE
6114000000-N	SP	3	HR	SPECIALIZED HAND MOWING
6117000000-N	SP	12	EA	RESPONSE FOR EROSION CONTROL
6123000000-E	1670	0.6	ACR	REFORESTATION

5/22/2008 10:08:09 AM \\proj\dwg\p\proj\b4300\_rdy\_sum.dgn









8/17/08

-L-  
PI Sta 13+19.9  
 $\Delta = 7'04''12.2''$   
 $D = 2'22''25.1''$   
 $L = 297.86'$   
 $T = 149.12'$   
 $R = 2,413.84'$

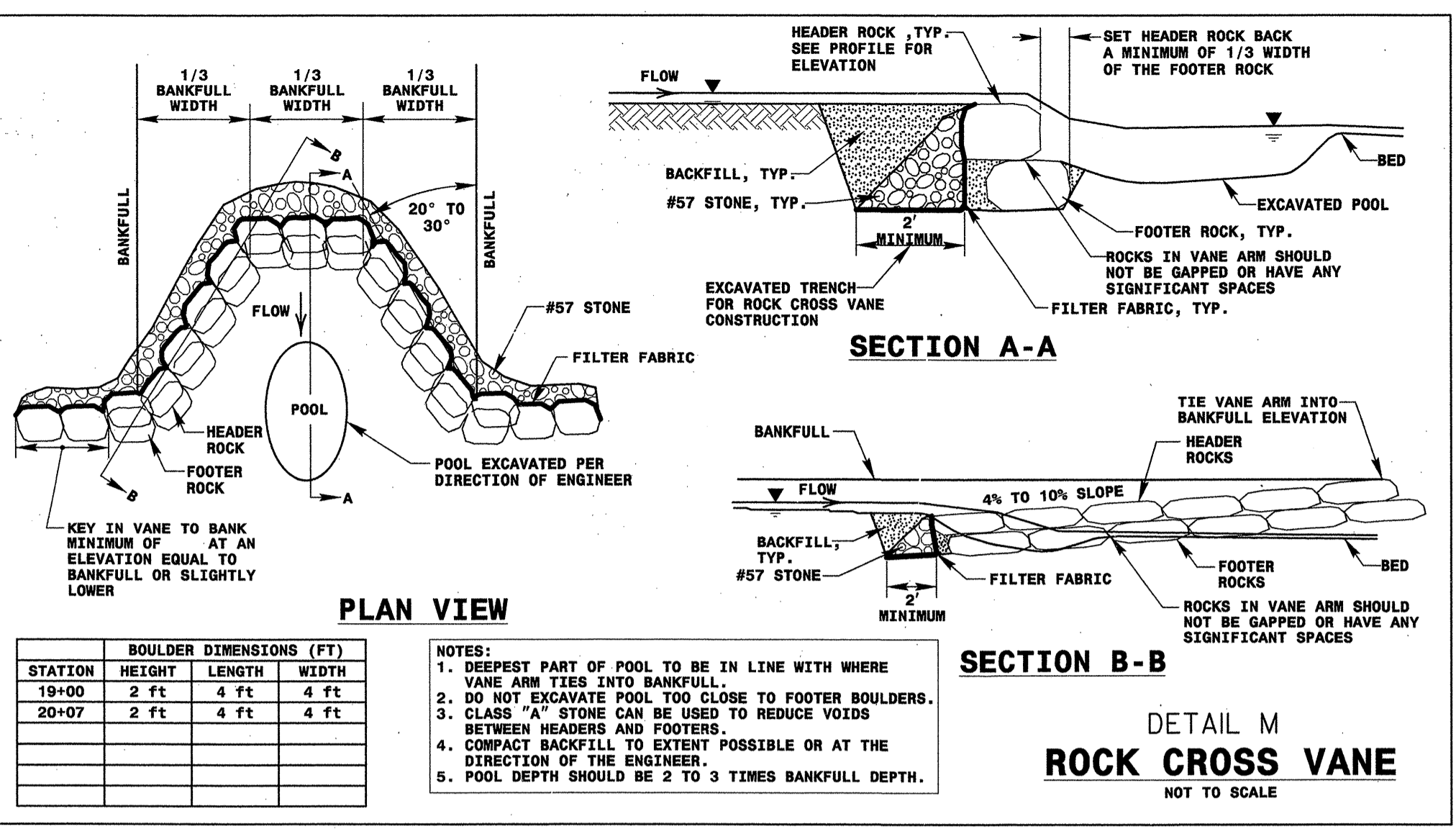
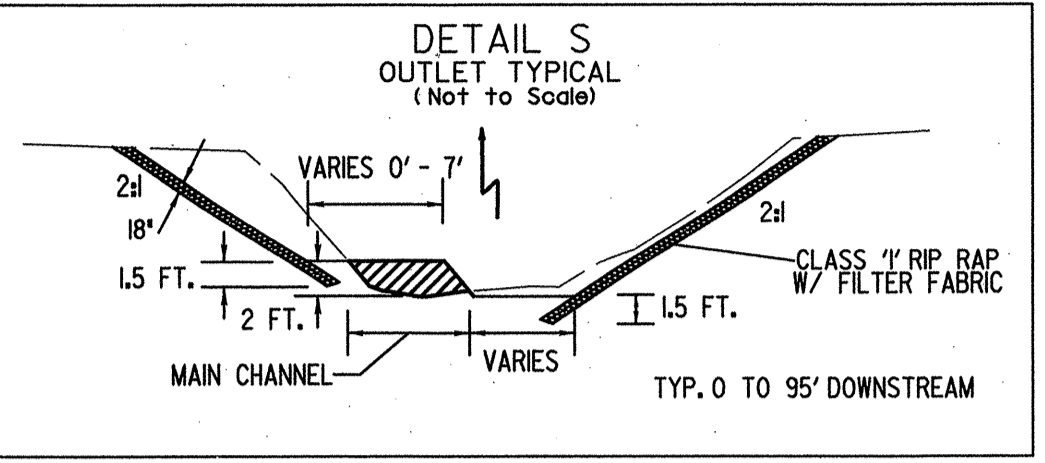
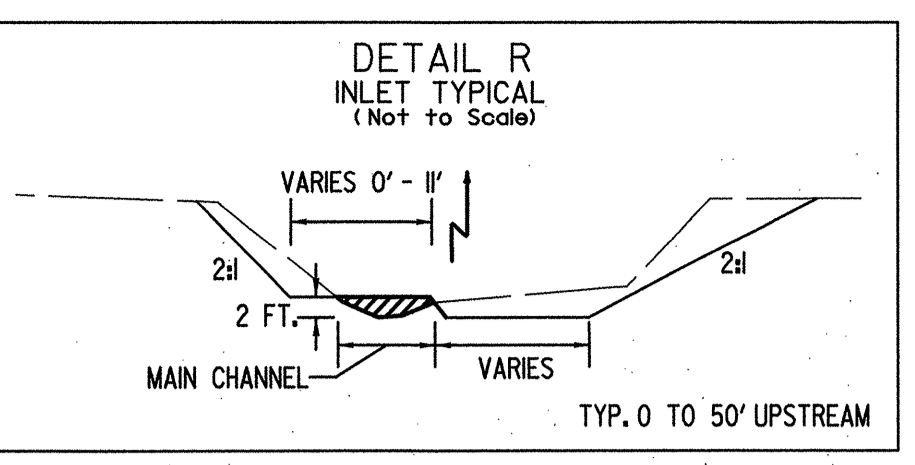
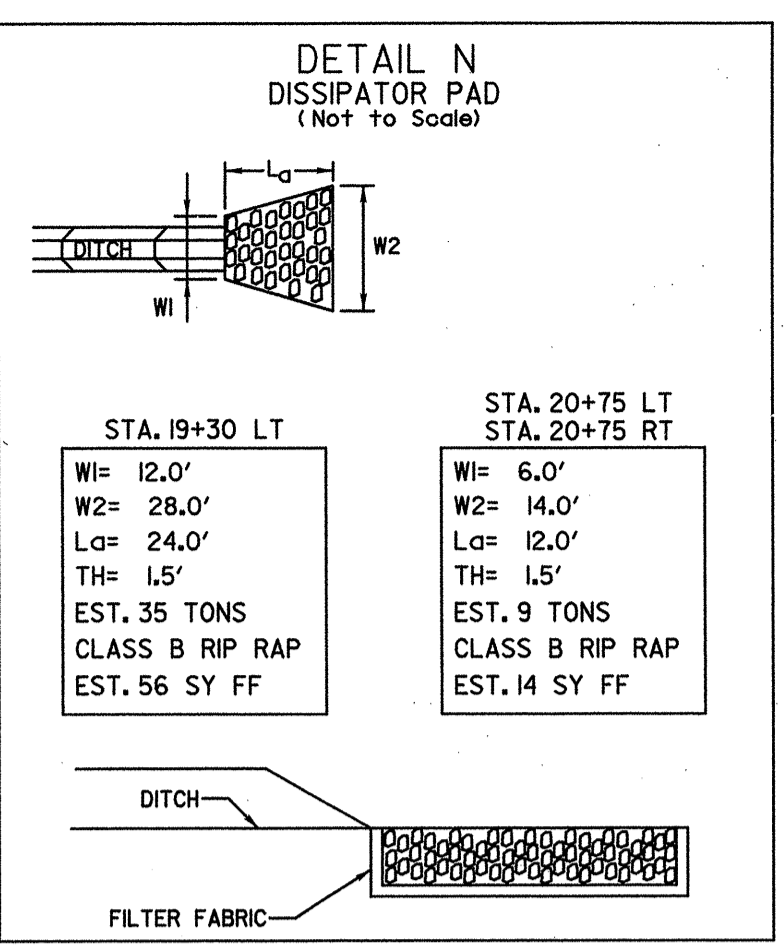

STATION	HEIGHT	LENGTH	WIDTH
19+00	2 ft	4 ft	4 ft
20+07	2 ft	4 ft	4 ft

- NOTES:
1. DEEPEST PART OF POOL TO BE IN LINE WITH WHERE VANE ARM TIES INTO BANKFULL.
  2. DO NOT EXCAVATE POOL TOO CLOSE TO FOOTER BOULDERS.
  3. CLASS "A" STONE CAN BE USED TO REDUCE VOIDS BETWEEN HEADERS AND FOOTERS.
  4. COMPACT BACKFILL TO EXTENT POSSIBLE OR AT THE DIRECTION OF THE ENGINEER.
  5. POOL DEPTH SHOULD BE 2 TO 3 TIMES BANKFULL DEPTH.

MULKEY ENGINEERS & CONSULTANTS  
PO BOX 38187  
RALEIGH, NC 27638  
(919) 881-1918 (FAX)  
(919) 881-1918 (CELL)  
WWW.MULKEYENGINEERS.COM

PROJECT REFERENCE NO. B-4300 SHEET NO. 4  
RW SHEET NO.  
ROADWAY DESIGN ENGINEER  
HYDRAULICS ENGINEER  
FOR -L- PROFILE SEE SHEET 5

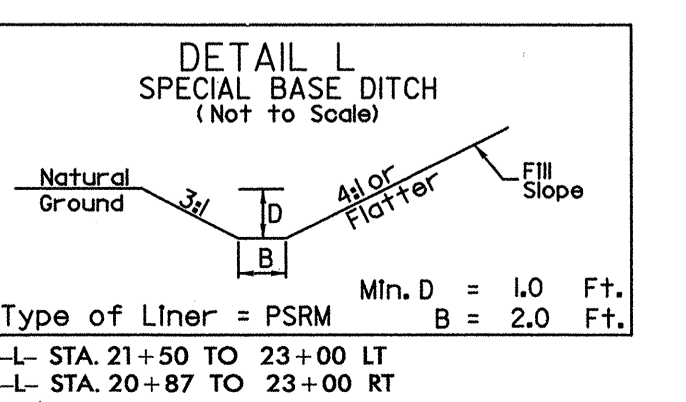
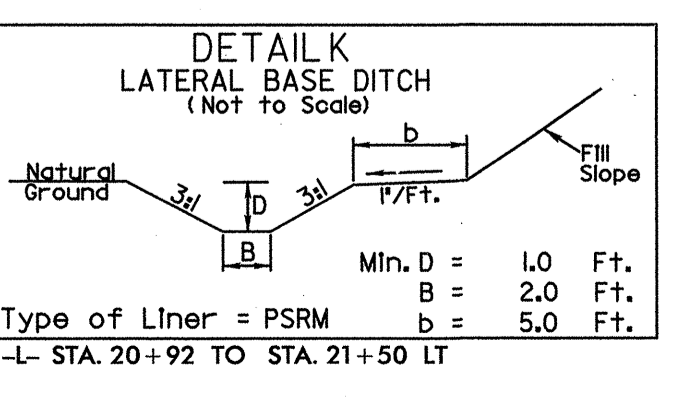
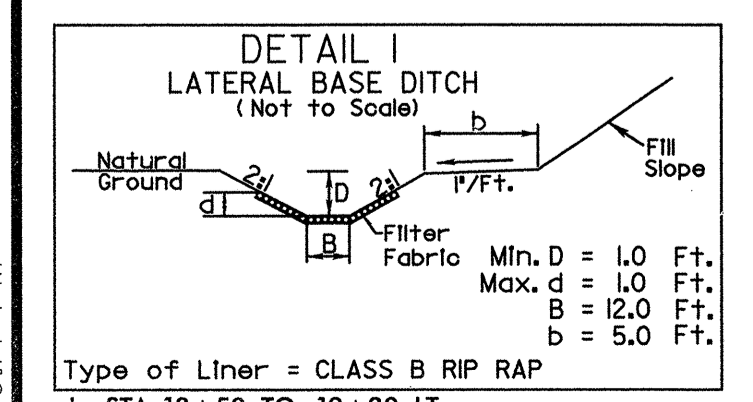
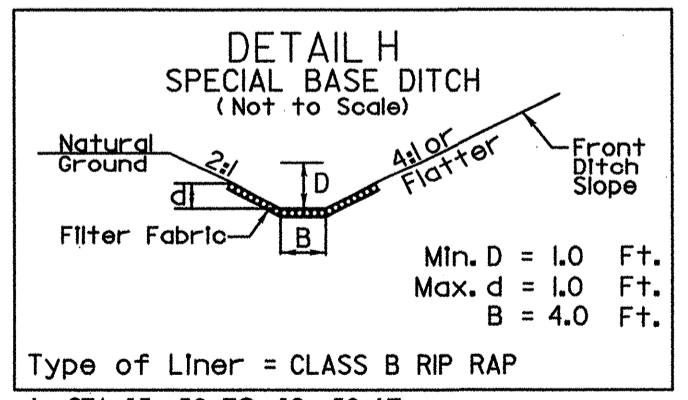
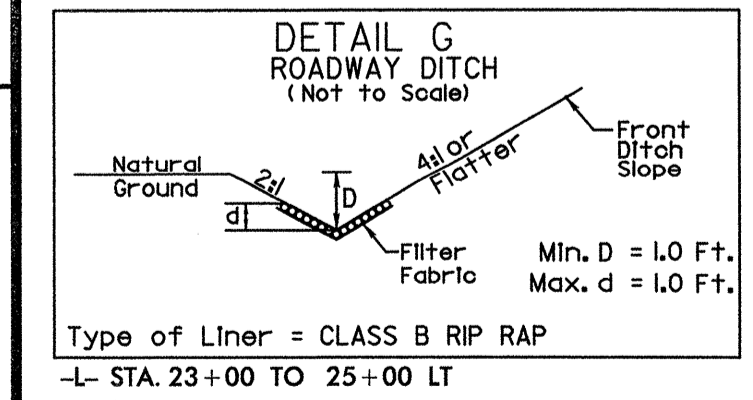
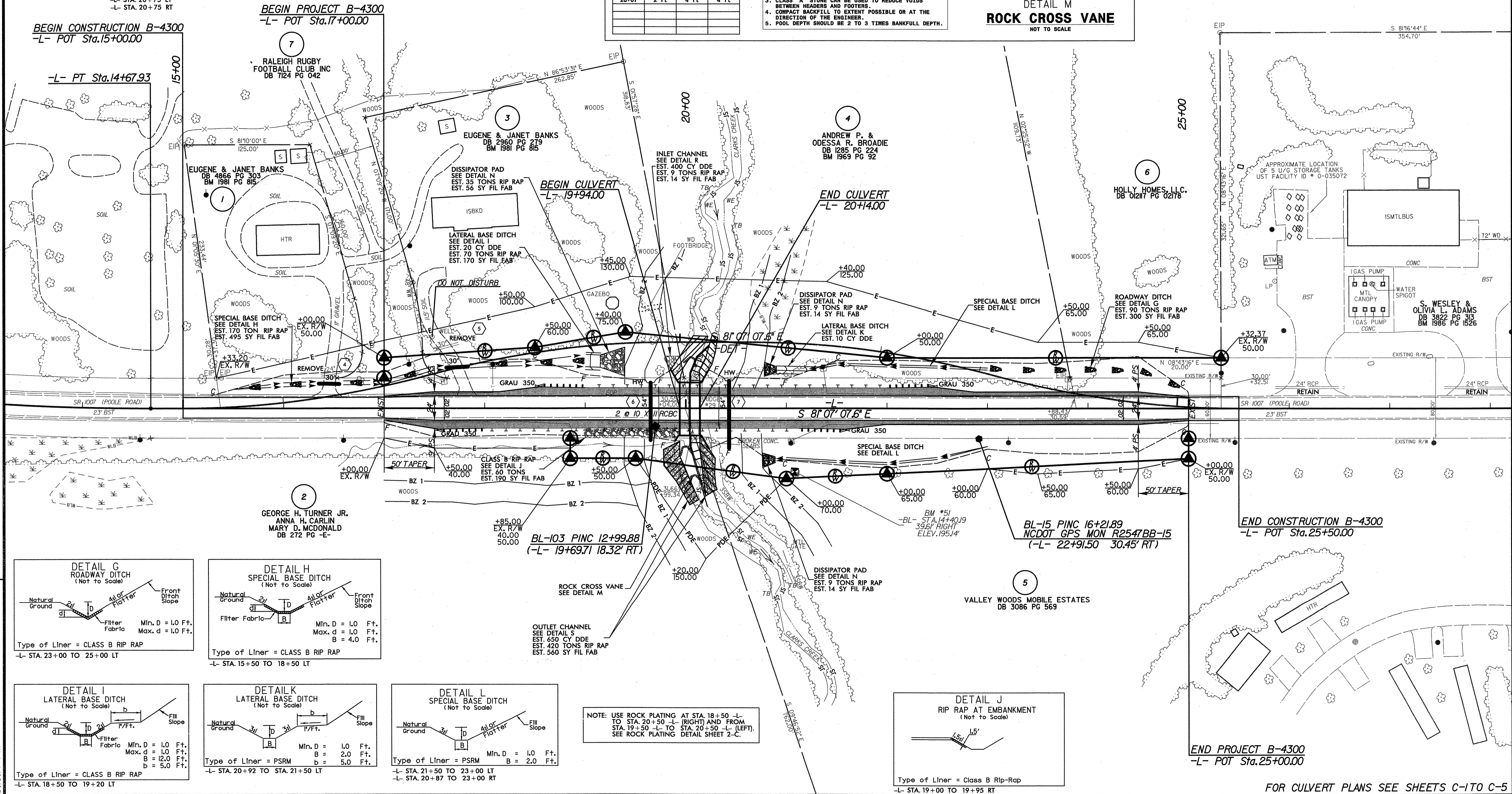

NOTE: USE ROCK PLATING AT STA. 18+50 -L- TO STA. 20+50 -L- (RIGHT) AND FROM STA. 19+50 -L- TO STA. 20+50 -L- (LEFT). SEE ROCK PLATING DETAIL SHEET 2-C.

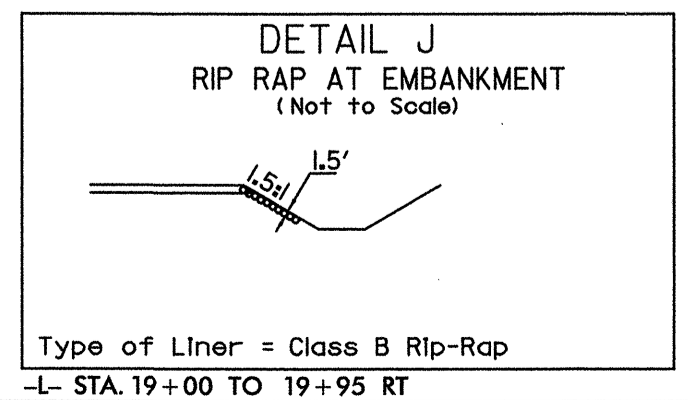

END PROJECT B-4300  
-L- POT Sta. 25+00.00

FOR CULVERT PLANS SEE SHEETS C-1 TO C-5

REVISIONS

5/29/2008  
S:\Roadway\Proj\B4300\_psh04.dgn  
3:04:44 PM



**CULVERT HYDRAULIC DATA**  
54" RCP (WEST)

DESIGN DISCHARGE	= 95	CFS
DESIGN FREQUENCY	= 50	YRS
DESIGN HW ELEVATION	= 196.2	FT
BASE DISCHARGE	= 104	CFS
BASE FREQUENCY	= 100	YRS
BASE HW ELEVATION	= 196.4	FT
OVERTOPPING DISCHARGE	= 165	CFS
OVERTOPPING FREQUENCY	= 100 +	YRS
OVERTOPPING ELEVATION	= 198.3	FT

**CULVERT HYDRAULIC DATA**  
54" RCP (EAST)

DESIGN DISCHARGE	= 95	CFS
DESIGN FREQUENCY	= 50	YRS
DESIGN HW ELEVATION	= 196.2	FT
BASE DISCHARGE	= 104	CFS
BASE FREQUENCY	= 100	YRS
BASE HW ELEVATION	= 196.4	FT
OVERTOPPING DISCHARGE	= 165	CFS
OVERTOPPING FREQUENCY	= 100 +	YRS
OVERTOPPING ELEVATION	= 198.3	FT

BM-#51  
RAILROAD SPIKE IN 16" PIN OAK  
-BL- STA 14+40 40' RIGHT  
EL = 195J4'  
-L- STA 21+08.43 63J9' RIGHT

**MULKEY**  
ENGINEERS & CONSULTANTS

1000 BAYVIEW DRIVE  
RALEIGH, N.C. 27606  
(919) 871-1912 FAX  
(919) 871-1912 IPAD  
WWW.MULKEYINC.COM

PROJECT REFERENCE NO. B-4300 SHEET NO. 5

ROADWAY DESIGN ENGINEER  
HYDRAULICS ENGINEER

**NORTH CAROLINA PROFESSIONAL ENGINEER**  
SEAL # 1102  
TIMOTHY J. JOHNSON

**NORTH CAROLINA PROFESSIONAL ENGINEER**  
SEAL # 026686  
JEFFREY L. RICH

