

STATE	STATE PROJECT REFERENCE NO.	SHEET NO.	TOTAL SHEETS
N.C.	B-4244	1	
WBS NO.	F.A. PROJ. NO.	DESCRIPTION	
33587.1.1	BRZ-2215(1)	P.E.	
33587.2.1	BRZ-2215(1)	R / W & UTIL	
33587.3.1	BRZ-2215(1)	CONSTR.	

STATE OF NORTH CAROLINA  
DIVISION OF HIGHWAYS

**RANDOLPH COUNTY**

LOCATION: BRIDGE NO. 140 OVER GABRIEL'S CREEK ON SR 2215

TYPE OF WORK: GRADING, DRAINAGE, PAVING, & STRUCTURE

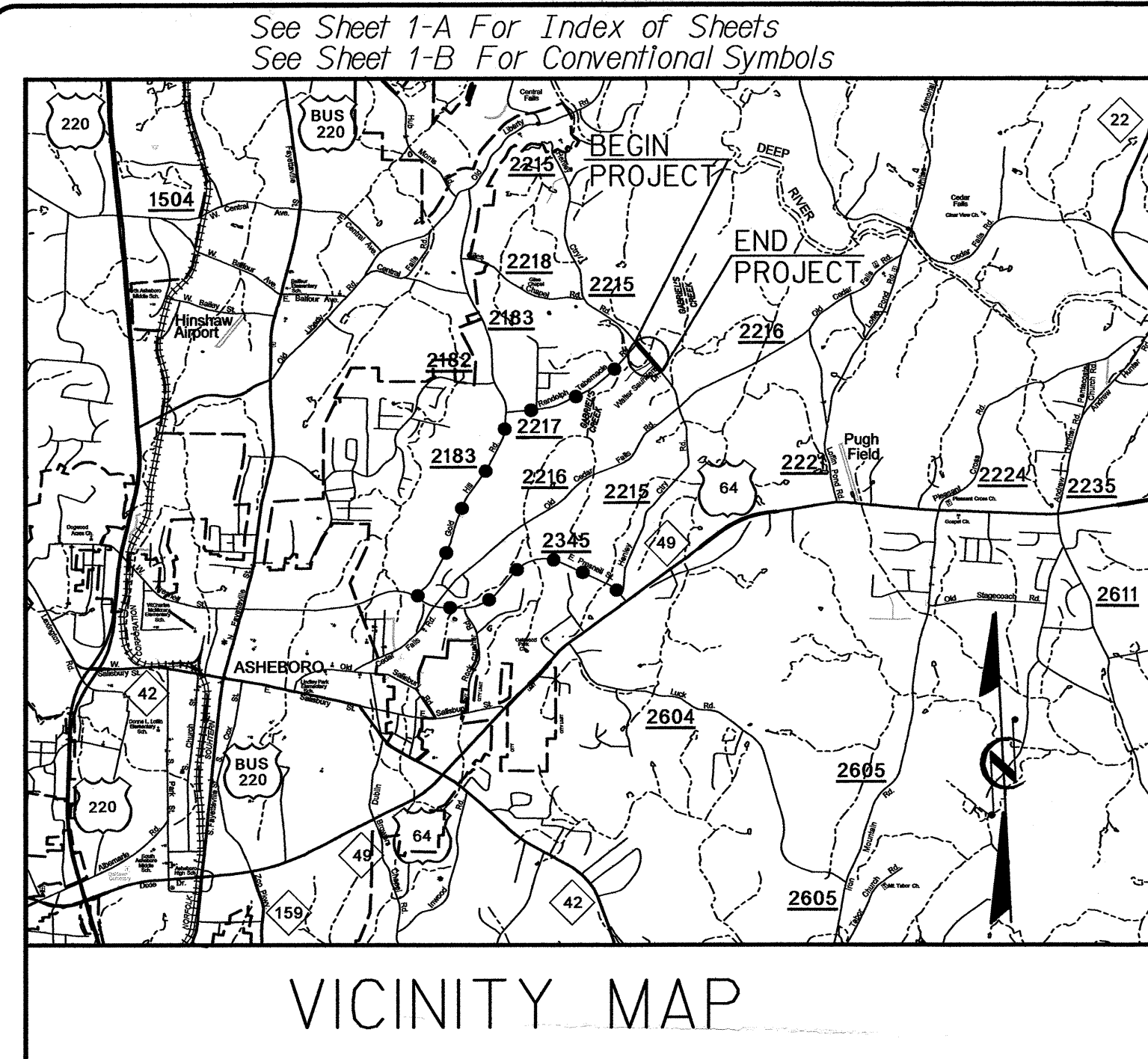

--- DENOTES OFF-SITE DETOUR

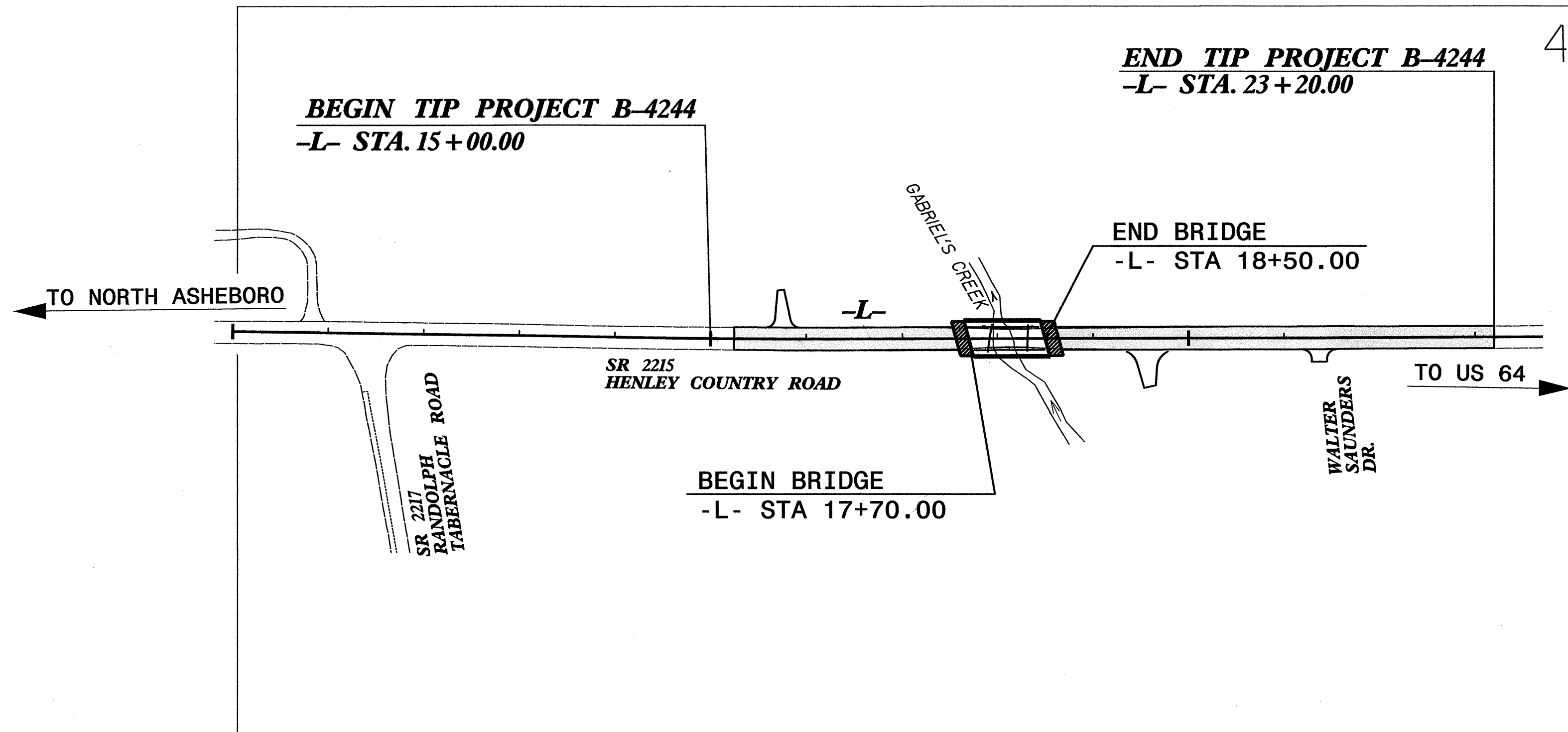

\* DESIGN EXCEPTION REQUIRED FOR VERTICAL CURVE  
K FACTOR, VERTICAL SSD, BRIDGE WIDTH AND MAX. GRADE.

NCDOT CONTACT: CATHY HOUSER, P.E.  
ROADWAY DESIGN - ENGINEERING COORDINATION

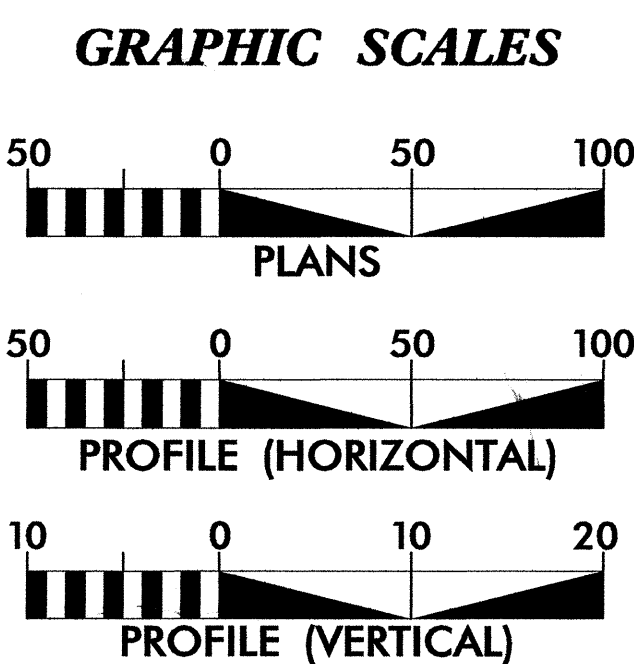

**DESIGN DATA**

ADT (2007) =	4,320
ADT (2027) =	7,970
DHV =	12 %
D =	60 %
T =	3 %
*V =	60 MPH
(TTST=1% + DUALS=2%)	

**PROJECT LENGTH**

LENGTH ROADWAY TIP PROJECT B-4244	=	0.140 MI.
LENGTH STRUCTURES TIP PROJECT B-4244	=	0.015 MI.
TOTAL LENGTH OF TIP PROJECT B-4244	=	0.155 MI.

Prepared In the Office of:

**KO & ASSOCIATES, P.C.**  
Consulting Engineers  
5121 Kingdom Way, Suite 100, Raleigh, NC 27607  
(919) 851-6066

2006 STANDARD SPECIFICATIONS

RIGHT OF WAY DATE:  
SEPTEMBER 15, 2006

LETTING DATE:  
JULY 15, 2008

MICHAEL A. YOUNG, PE  
PROJECT ENGINEER

BRIAN A. WILES, PE  
PROJECT DESIGN ENGINEER

HYDRAULICS ENGINEER

Walter Saunders Dr. Signature: *Walter Saunders*

ROADWAY DESIGN ENGINEER

Michael A. Young Signature: *Michael A. Young*

Professional Engineer Seals for Michael A. Young (Seal 21162) and Brian A. Wiles (Seal 022982).

DIVISION OF HIGHWAYS  
STATE OF NORTH CAROLINA

Art McMillan  
STATE HIGHWAY DESIGN ENGINEER

09/08/09  
 4/22/2008  
 R:\Roadway\Proj\B4244\_Rdy\_tsh.dgn  
 KO & Associates, P.C.  
 CONTRACT: C201873  
 TIP PROJECT: B-4244

5/14/99

B.M.#1 EL = 631.84  
 RR SPIKE IN BASE OF  
 POWER POLE (CP&L K808AD)  
 42' RT OF -BL- STA 6+22  
 61.29' RT OF -L- STA 12+35.44

B.M.#2 EL = 607.35  
 RR SPIKE IN BASE OF  
 POWER POLE (CP&L K794AD)  
 75' RT OF -BL- STA 13+19  
 90.12' RT OF -L- STA 19+90.63

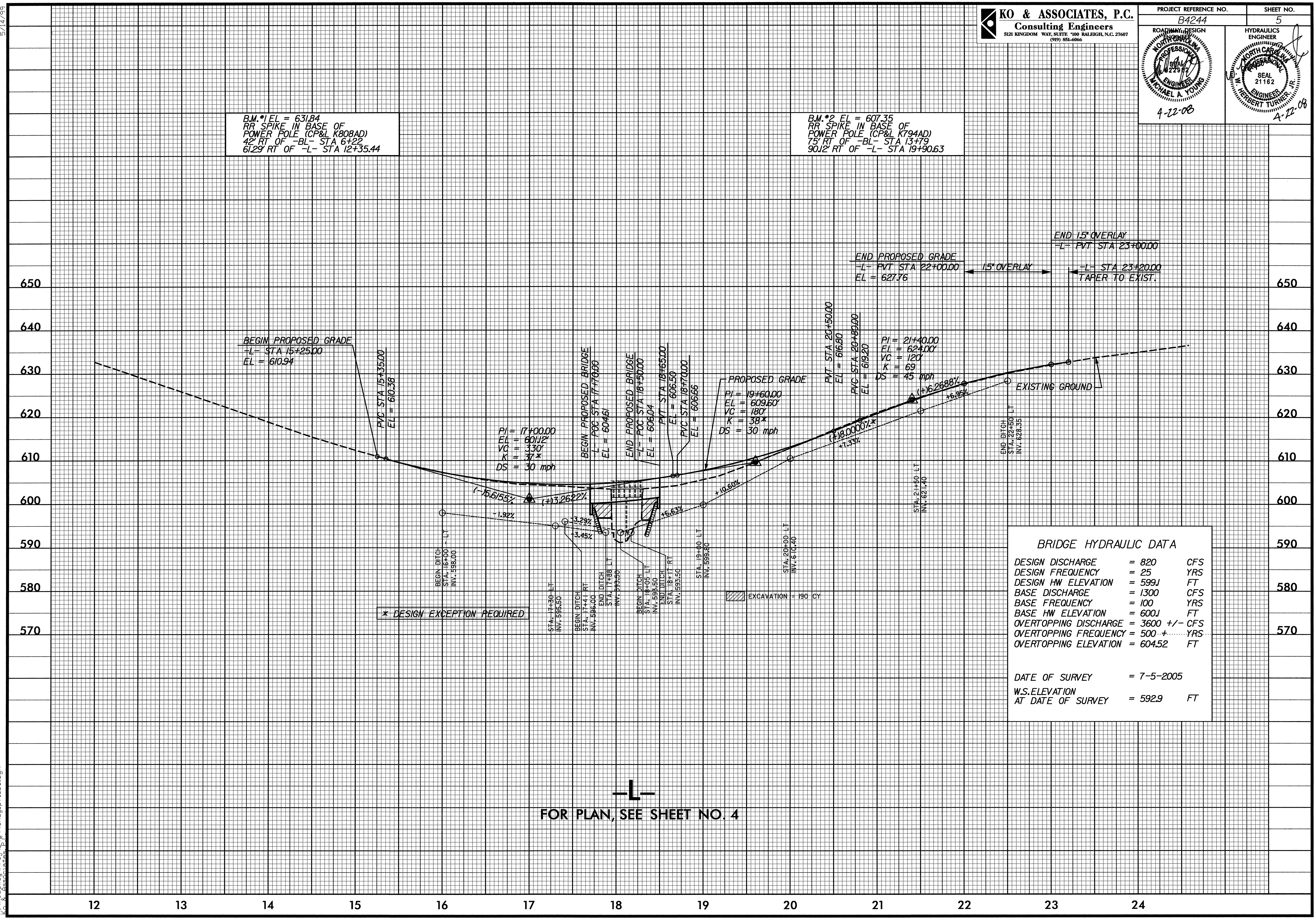

\* DESIGN EXCEPTION REQUIRED

**BRIDGE HYDRAULIC DATA**

DESIGN DISCHARGE	= 820	CFS
DESIGN FREQUENCY	= 25	YRS
DESIGN HW ELEVATION	= 599J	FT
BASE DISCHARGE	= 1300	CFS
BASE FREQUENCY	= 100	YRS
BASE HW ELEVATION	= 600J	FT
OVERTOPPING DISCHARGE	= 3600 +/-	CFS
OVERTOPPING FREQUENCY	= 500 +	YRS
OVERTOPPING ELEVATION	= 604.52	FT

DATE OF SURVEY = 7-5-2005  
 W.S.ELEVATION AT DATE OF SURVEY = 592.9 FT

—L—  
 FOR PLAN, SEE SHEET NO. 4

4/22/2008  
 P:\Roadway\Proj\B4244-Rd\pfl1.05.dgn

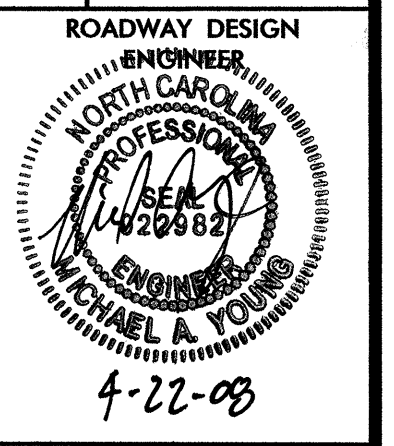

# INDEX OF SHEETS

# GENERAL NOTES:

# 2006 ROADWAY STANDARD DRAWINGS

EFF. 07-18-06  
REV. 01-02-07

SHEET NUMBER	DESCRIPTION
1	Title Sheet
1-A	Index of Sheets, General Notes and List of Standards
1-B	Conventional Symbols
1-C	Survey Control Sheet
2	Typical Sections, Wedging Detail and Pavement Schedule
2-A	Anchorage for Frames Detail
3	Summary of Quantities
3-A	Summary of Earthwork
3-B	Summaries of Drainage, Guardrail and Pavement Removal
4	Plan Sheet
5	Profile Sheet
TCP-1 thru TCP-3	Traffic Control Plans
SD-1	Special Sign Design
EC-1 thru EC-5	Erosion Control Plans
U0-1 thru U0-2	Utility by Others
X-1	Cross-Section Summary Sheet
X-2 thru X-6	Cross-Sections
S-1 thru S-25	Structure Plans

**GENERAL NOTES:**

2006 SPECIFICATIONS  
EFFECTIVE: 07-18-06  
REVISED: 07-18-06

**GRADE LINE:  
GRADING AND SURFACING:**

THE GRADE LINES SHOWN DENOTE THE FINISHED ELEVATION OF THE PROPOSED SURFACING AT GRADE POINTS SHOWN ON THE TYPICAL SECTIONS. GRADE LINES MAY BE ADJUSTED AT THEIR BEGINNING AND ENDING AND AT STRUCTURES AS DIRECTED BY THE ENGINEER IN ORDER TO SECURE A PROPER TIE-IN.

**CLEARING:**

CLEARING ON THIS PROJECT SHALL BE PERFORMED TO THE LIMITS ESTABLISHED BY METHOD II.

**SUPERELEVATION:**

ALL CURVES ON THIS PROJECT SHALL BE SUPERELEVATED IN ACCORDANCE WITH STD. NO. 225.04 USING THE RATE OF SUPERELEVATION AND RUNOFF SHOWN ON THE PLANS. SUPERELEVATION IS TO BE REVOLVED ABOUT THE GRADE POINTS SHOWN ON THE TYPICAL SECTIONS.

**SHOULDER CONSTRUCTION:**

ASPHALT, EARTH, AND CONCRETE SHOULDER CONSTRUCTION ON THE HIGH SIDE OF SUPERELEVATED CURVES SHALL BE IN ACCORDANCE WITH STD. NO. 560.01.

**SIDE ROADS:**

THE CONTRACTOR WILL BE REQUIRED TO DO ALL NECESSARY WORK TO PROVIDE SUITABLE CONNECTIONS WITH ALL ROADS, STREETS, AND DRIVES ENTERING THIS PROJECT. THIS WORK WILL BE PAID FOR AT THE CONTRACT UNIT PRICE FOR THE PARTICULAR ITEMS INVOLVED.

**GUARDRAIL:**

THE GUARDRAIL LOCATIONS SHOWN ON THE PLANS MAY BE ADJUSTED DURING CONSTRUCTION AS DIRECTED BY THE ENGINEER. THE CONTRACTOR SHOULD CONSULT WITH THE ENGINEER PRIOR TO ORDERING GUARDRAIL MATERIAL.

**TEMPORARY SHORING:**

SHORING REQUIRED FOR THE MAINTENANCE OF TRAFFIC WILL BE PAID FOR AS "EXTRA WORK" IN ACCORDANCE WITH SECTION 104-7.

**SUBSURFACE PLANS:**

NO SUBSURFACE PLANS ARE AVAILABLE ON THIS PROJECT. THE CONTRACTOR SHOULD MAKE HIS OWN INVESTIGATION AS TO THE SUBSURFACE CONDITIONS.

**END BENTS:**

THE ENGINEER SHALL CHECK THE STRUCTURE END BENT PLANS, DETAILS, AND CROSS-SECTION PRIOR TO SETTING OF THE SLOPE STAKES FOR THE EMBANKMENT OR EXCAVATION APPROACHING A BRIDGE.

**UTILITIES:**

UTILITY OWNERS ON THIS PROJECT ARE  
Progress Energy, Embarq & Piedmont Natural Gas.

ANY RELOCATION OF EXISTING UTILITIES WILL BE ACCOMPLISHED BY OTHERS.

**RIGHT-OF-WAY MARKERS:**

ALL RIGHT-OF-WAY MARKERS ON THIS PROJECT SHALL BE PLACED BY CONTRACT.

### 2006 ROADWAY ENGLISH STANDARD DRAWINGS

The following Roadway Standards as appear in "Roadway Standard Drawings" Highway Design Branch - N. C. Department of Transportation - Raleigh, N. C., Dated July 18, 2006 are applicable to this project and by reference hereby are considered a part of these plans:

STD.NO.	TITLE
DIVISION 2 - EARTHWORK	
200.02	Method of Clearing - Method II
225.02	Guide for Grading Subgrade - Secondary and Local
225.04	Method of Obtaining Superelevation - Two Lane Pavement
DIVISION 3 - PIPE CULVERTS	
300.01	Method of Pipe Installation - Method 'A'
310.10	Driveway Pipe Construction
DIVISION 4 - MAJOR STRUCTURES	
422.10	Reinforced Bridge Approach Fills
DIVISION 5 - SUBGRADE, BASES AND SHOULDERS	
560.01	Method of Shoulder Construction - High Side of Superelevated Curve - Method I
DIVISION 8 - INCIDENTALS	
806.01	Concrete Right-of-Way Marker
806.02	Granite Right-of-Way Marker
840.18	Concrete Grated Drop Inlet Type 'B' - 12" thru 36" Pipe
840.27	Brick Grated Drop Inlet Type 'B' - 12" thru 36" Pipe
840.29	Frames and Narrow Slot Flat Grates
840.45	Precast Drainage Structure
846.01	Concrete Curb, Gutter and Curb & Gutter
846.04	Drop Inlet Installation in Shoulder Berm Gutter
862.01	Guardrail Placement
862.02	Guardrail Installation
862.03	Structure Anchor Units
862.04	Anchoring End of Guardrail - B-77 and B-83 Anchor Units
876.01	Rip Rap in Channels
876.02	Guide for Rip Rap at Pipe Outlets
876.04	Drainage Ditches with Class 'B' Rip Rap













Note: Not to Scale

\*S.U.E. = Subsurface Utility Engineering











STATE OF NORTH CAROLINA  
DIVISION OF HIGHWAYS

CONVENTIONAL PLAN SHEET SYMBOLS











**BOUNDARIES AND PROPERTY:**

State Line	_____
County Line	_____
Township Line	_____
City Line	_____
Reservation Line	_____
Property Line	_____
Existing Iron Pin	_____ 
Property Corner	_____ 
Property Monument	_____ 
Parcel/Sequence Number	_____ 
Existing Fence Line	_____ 
Proposed Woven Wire Fence	_____ 
Proposed Chain Link Fence	_____ 
Proposed Barbed Wire Fence	_____ 
Existing Wetland Boundary	_____ 
Proposed Wetland Boundary	_____ 
Existing Endangered Animal Boundary	_____ 
Existing Endangered Plant Boundary	_____ 





**BUILDINGS AND OTHER CULTURE:**

Gas Pump Vent or U/G Tank Cap	_____ 
Sign	_____ 
Well	_____ 
Small Mine	_____ 
Foundation	_____ 
Area Outline	_____ 
Cemetery	_____ 
Building	_____ 
School	_____ 
Church	_____ 
Dam	_____ 



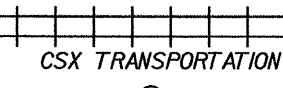
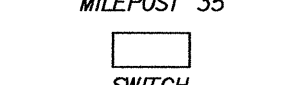









**HYDROLOGY:**

Stream or Body of Water	_____
Hydro, Pool or Reservoir	_____ 
Jurisdictional Stream	_____ 
Buffer Zone 1	_____ 
Buffer Zone 2	_____ 
Flow Arrow	_____ 
Disappearing Stream	_____ 
Spring	_____ 
Wetland	_____ 
Proposed Lateral, Tail, Head Ditch	_____ 
False Sump	_____ 

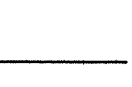



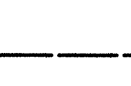

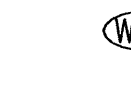

**RAILROADS:**

Standard Gauge	_____ 
RR Signal Milepost	_____ 
Switch	_____ 
RR Abandoned	_____ 
RR Dismantled	_____ 

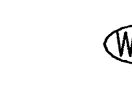
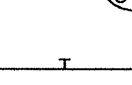
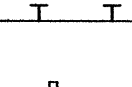
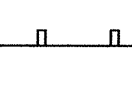

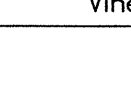

**RIGHT OF WAY:**

Baseline Control Point	_____ 
Existing Right of Way Marker	_____ 
Existing Right of Way Line	_____ 
Proposed Right of Way Line	_____ 
Proposed Right of Way Line with Iron Pin and Cap Marker	_____ 
Proposed Right of Way Line with Concrete or Granite Marker	_____ 
Existing Control of Access	_____ 
Proposed Control of Access	_____ 
Existing Easement Line	_____ 
Proposed Temporary Construction Easement	_____ 
Proposed Temporary Drainage Easement	_____ 
Proposed Permanent Drainage Easement	_____ 
Proposed Permanent Utility Easement	_____ 



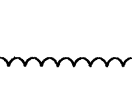

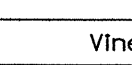

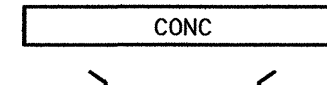

**ROADS AND RELATED FEATURES:**

Existing Edge of Pavement	_____ 
Existing Curb	_____ 
Proposed Slope Stakes Cut	_____ 
Proposed Slope Stakes Fill	_____ 
Proposed Wheel Chair Ramp	_____ 
Proposed Wheel Chair Ramp Curb Cut	_____ 
Curb Cut for Future Wheel Chair Ramp	_____ 
Existing Metal Guardrail	_____ 
Proposed Guardrail	_____ 
Existing Cable Guiderail	_____ 
Proposed Cable Guiderail	_____ 
Equality Symbol	_____ 
Pavement Removal	_____ 

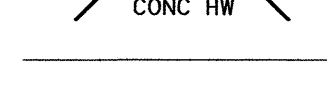

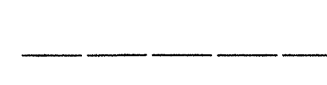
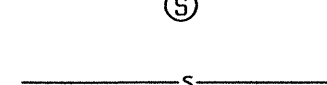





**VEGETATION:**

Single Tree	_____ 
Single Shrub	_____ 
Hedge	_____ 
Woods Line	_____ 
Orchard	_____ 
Vineyard	_____ 

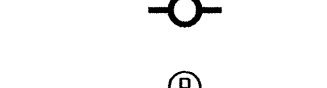

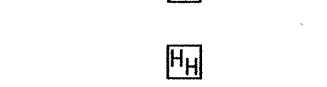
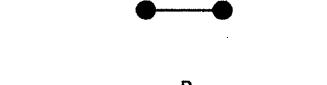
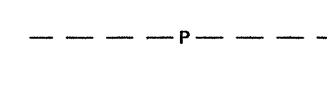

**EXISTING STRUCTURES:**

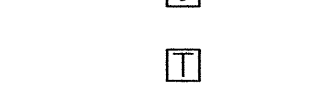
MAJOR:	
Bridge, Tunnel or Box Culvert	_____ 
Bridge Wing Wall, Head Wall and End Wall	_____ 
MINOR:	
Head and End Wall	_____ 
Pipe Culvert	_____ 
Footbridge	_____ 
Drainage Box: Catch Basin, DI or JB	_____ 
Paved Ditch Gutter	_____ 
Storm Sewer Manhole	_____ 
Storm Sewer	_____ 



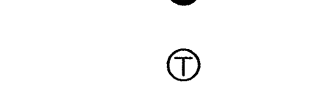
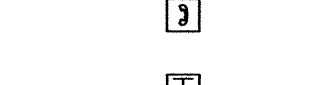

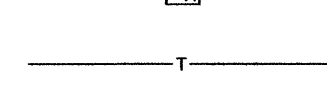
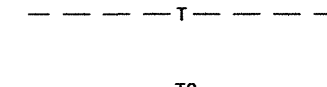
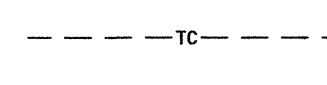
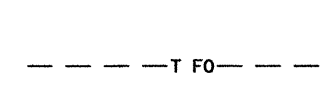
**UTILITIES:**

POWER:	
Existing Power Pole	_____ 
Proposed Power Pole	_____ 
Existing Joint Use Pole	_____ 
Proposed Joint Use Pole	_____ 
Power Manhole	_____ 
Power Line Tower	_____ 
Power Transformer	_____ 
U/G Power Cable Hand Hole	_____ 
H-Frame Pole	_____ 
Recorded U/G Power Line	_____ 
Designated U/G Power Line (S.U.E.*)	_____ 



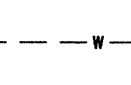
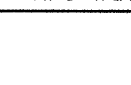

**TELEPHONE:**

Existing Telephone Pole	_____ 
Proposed Telephone Pole	_____ 
Telephone Manhole	_____ 
Telephone Booth	_____ 
Telephone Pedestal	_____ 
Telephone Cell Tower	_____ 
U/G Telephone Cable Hand Hole	_____ 
Recorded U/G Telephone Cable	_____ 
Designated U/G Telephone Cable (S.U.E.*)	_____ 
Recorded U/G Telephone Conduit	_____ 
Designated U/G Telephone Conduit (S.U.E.*)	_____
Recorded U/G Fiber Optics Cable	_____
Designated U/G Fiber Optics Cable (S.U.E.*)	_____

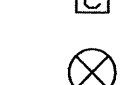

**WATER:**

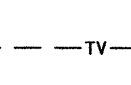
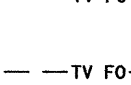
Water Manhole	_____ 
Water Meter	_____ 
Water Valve	_____ 
Water Hydrant	_____ 
Recorded U/G Water Line	_____ 
Designated U/G Water Line (S.U.E.*)	_____ 
Above Ground Water Line	_____ 

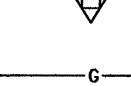

**TV:**

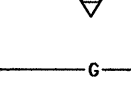
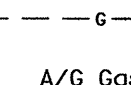
TV Satellite Dish	_____ 
TV Pedestal	_____ 
TV Tower	_____ 
U/G TV Cable Hand Hole	_____ 
Recorded U/G TV Cable	_____ 
Designated U/G TV Cable (S.U.E.*)	_____ 
Recorded U/G Fiber Optic Cable	_____ 
Designated U/G Fiber Optic Cable (S.U.E.*)	_____ 



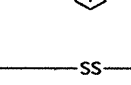
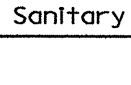
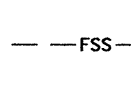

**GAS:**

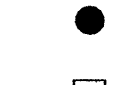
Gas Valve	_____ 
Gas Meter	_____ 
Recorded U/G Gas Line	_____ 
Designated U/G Gas Line (S.U.E.*)	_____ 
Above Ground Gas Line	_____ 

**SANITARY SEWER:**

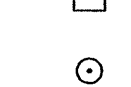
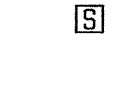
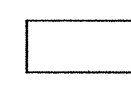
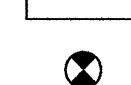
Sanitary Sewer Manhole	_____ 
Sanitary Sewer Cleanout	_____ 
U/G Sanitary Sewer Line	_____ 
Above Ground Sanitary Sewer	_____ 
Recorded SS Forced Main Line	_____ 
Designated SS Forced Main Line (S.U.E.*)	_____ 

**MISCELLANEOUS:**

Utility Pole	_____ 
Utility Pole with Base	_____ 
Utility Located Object	_____ 
Utility Traffic Signal Box	_____ 
Utility Unknown U/G Line	_____ 
U/G Tank; Water, Gas, Oil	_____ 
A/G Tank; Water, Gas, Oil	_____ 
U/G Test Hole (S.U.E.*)	_____ 
Abandoned According to Utility Records	_____
End of Information	_____

6/2/99

PROJECT REFERENCE NO.	SHEET NO.
B-4244	1C
Location and Surveys	

# SURVEY CONTROL SHEET B-4244

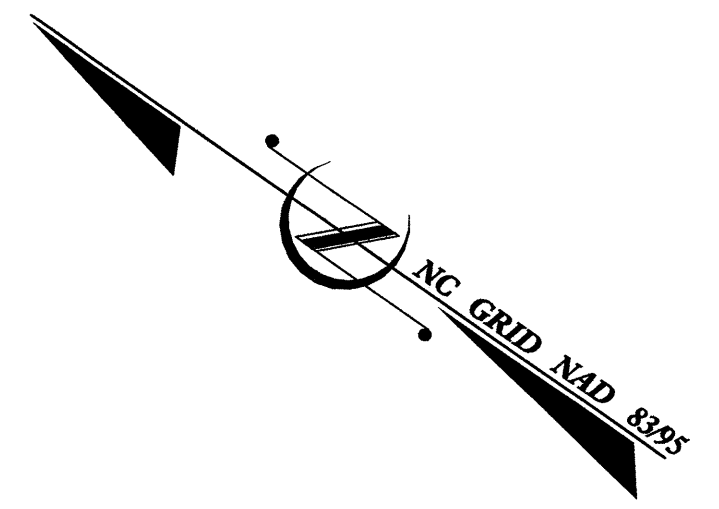

**-L- STA. 23+20.00 END TIP PROJECT B-4244  
LOCALIZED PROJECT COORDINATES**  
 N = 724473.9469  
 E = 1773943.3508

NCDOT GPS STATION "B4244-2"  
LOCALIZED PROJECT COORDINATES  
 N = 724379.8180  
 E = 1774044.9230

**NCDOT BASELINE STATION "BL-101"  
LOCALIZED PROJECT COORDINATES**  
 N = 725385.0750  
 E = 1773151.0620

**-L- SR 2215  
HENLEY COUNTRY ROAD**

GABRIEL'S CREEK

**NCDOT BASELINE STATION "BL-102"  
LOCALIZED PROJECT COORDINATES**  
 N = 724813.0420  
 E = 1773637.9020

**NCDOT BASELINE STATION "BL-103"  
LOCALIZED PROJECT COORDINATES**  
 N = 724557.0250  
 E = 1773849.2030

TO US 64

**-L- STA. 15+00.00 BEGIN TIP PROJECT B-4244  
LOCALIZED PROJECT COORDINATES**  
 N = 725099.6201  
 E = 1773413.3256

TO NORTH ASHEBORO

## DATUM DESCRIPTION

THE LOCALIZED COORDINATE SYSTEM DEVELOPED FOR THIS PROJECT IS BASED ON THE STATE PLANE COORDINATES ESTABLISHED BY NCDOT FOR MONUMENT "B4244-1" WITH NAD 83/95 STATE PLANE GRID COORDINATES OF NORTHING: 725559.399(ft) EASTING: 1773013.784(ft) THE AVERAGE COMBINED GRID FACTOR USED ON THIS PROJECT (GROUND TO GRID) IS: 0.999882860 THE N.C. LAMBERT GRID BEARING AND LOCALIZED HORIZONTAL GROUND DISTANCE FROM "B4244-1" TO -L- STATION 15+00.00 IS S 40°59'24.71" E 609.122' ALL LINEAR DIMENSIONS ARE LOCALIZED HORIZONTAL DISTANCES VERTICAL DATUM USED IS NAVD 88

## NOTES:

- THE CONTROL DATA FOR THIS PROJECT CAN BE FOUND ELECTRONICALLY BY SELECTING PROJECT CONTROL DATA AT:  
[HTTP://WWW.NCDOT.ORG/DOH/PRECONSTRUCT/HIGHWAY/LOCATION/PROJECT/](http://www.ncdot.org/DOH/PRECONSTRUCT/HIGHWAY/LOCATION/PROJECT/)  
THE FILES TO BE FOUND ARE AS FOLLOWS:  
B-4244\_LS\_CONTROL\_051103.TXT
- SITE CALIBRATION INFORMATION HAS NOT BEEN PROVIDED FOR THIS PROJECT. IF FURTHER INFORMATION IS NEEDED, PLEASE CONTACT THE LOCATION AND SURVEYS UNIT.
- © INDICATES GEODETIC CONTROL MONUMENTS USED OR SET FOR HORIZONTAL PROJECT CONTROL BY THE NCDOT LOCATION AND SURVEYS UNIT.  
PROJECT CONTROL ESTABLISHED USING GLOBAL POSITIONING SYSTEM.

BL POINT	DESC.	NORTH	EAST	ELEVATION	L STATION	OFFSET
101	BL-101	725385.0750	1773151.0620	637.21	11+12.98	21.87 RT
102	BL-102	724813.0420	1773637.9020	603.58	10+63.82	13.23 RT
103	BL-103	724557.0250	1773849.2030	626.94	21+95.72	17.72 RT
2	B4244-2	724379.8180	1774044.9230	635.95	24+57.54	16.16 LT

.....  
 BM #1 ELEVATION = 631.84  
 N 725265 E 1773198  
 L STATION 12+35 61 RIGHT  
 RR SPIKE IN BASE OF POWER POLE (\*\*K988AD)  
 .....  
 BM #2 ELEVATION = 607.35  
 N 724667 E 1773661  
 L STATION 19+91 98 RIGHT  
 RR SPIKE IN BASE OF POWER POLE (\*\*K794AD)  
 .....

NOTE: DRAWING NOT TO SCALE

4/22/2008  
P:\Roadway\ProJ\4244\_1s\_1c.dgn

6/2/99

### PAVEMENT SCHEDULE

C	PROP. APPROX. 1½" ASPHALT CONCRETE SURFACE COURSE, TYPE S9.5B, AT AN AVERAGE RATE OF 168 LBS. PER SQ. YD.
C1	PROP. APPROX. 3" ASPHALT CONCRETE SURFACE COURSE, TYPE S9.5B, AT AN AVERAGE RATE OF 168 LBS. PER SQ. YD. IN EACH OF TWO LAYERS.
D1	PROP. APPROX. 2½" ASPHALT CONCRETE INTERMEDIATE COURSE, TYPE I19.0B, AT AN AVERAGE RATE OF 285 LBS. PER SQ. YD.
E1	PROP. APPROX. 4" ASPHALT CONCRETE BASE COURSE, TYPE B25.0B, AT AN AVERAGE RATE OF 456 LBS. PER SQ. YD.
T	EARTH MATERIAL.
U	EXISTING PAVEMENT

**KO & ASSOCIATES, P.C.**  
 Consulting Engineers  
 5121 KINGDOM WAY, SUITE 100 RALEIGH, N.C. 27607  
 (919) 551-6966

PROJECT REFERENCE NO. B-4244	SHEET NO. 2
ROADWAY DESIGN ENGINEER MICHAEL A. YOUNG SEAL 102295 4-7-22-08	PAVEMENT DESIGN ENGINEER JON-CHI CHEN SEAL 13768 4/25/08

NOTE: PAVEMENT EDGE SLOPES ARE 1:1 UNLESS SHOWN OTHERWISE.

\* ADD 3' WITH GUARDRAIL

TRANSITION FROM EXISTING TO T.S. NO. 1  
 -L- STA. 15+25.00 TO 15+75.00

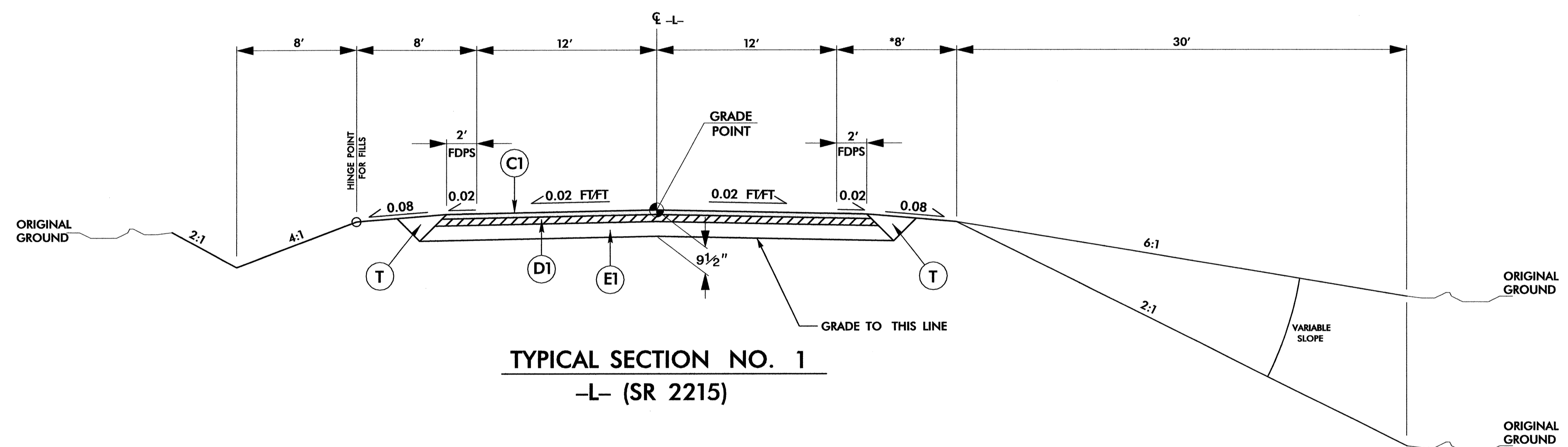

USE TYPICAL SECTION NO. 1  
 -L- STA. 15+75.00 TO 17+70.00 (BEGIN BRIDGE)  
 -L- STA. 18+50.00 (END BRIDGE) TO 21+50.00

TRANSITION FROM T.S. NO. 1 TO T.S. NO. 2  
 -L- STA. 21+50.00 TO 22+00.00

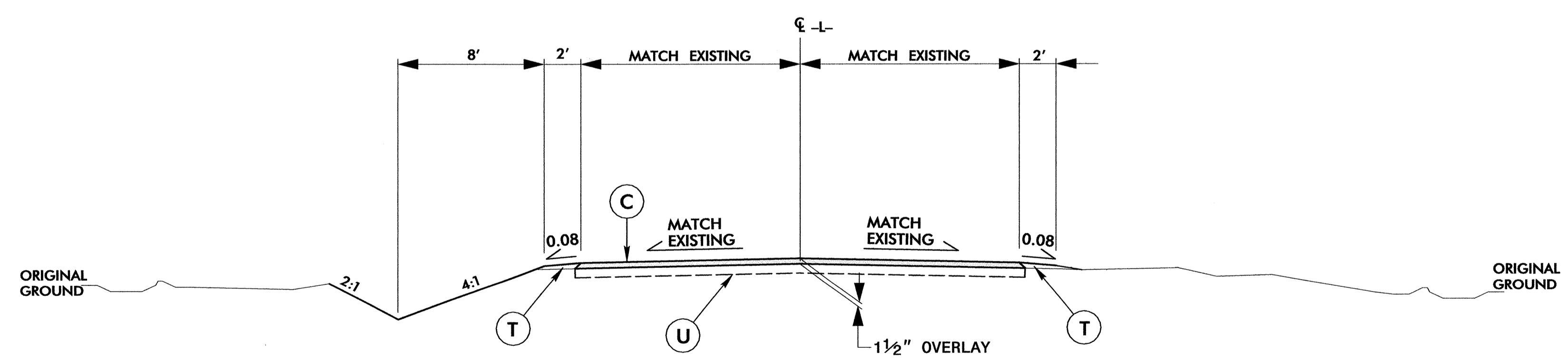

USE TYPICAL SECTION NO. 2  
 -L- STA. 22+00.00 TO 23+20.00

TYPICAL SECTION NO. 2  
 -L- (SR 2215)

4/26/2008 P:\Roadway\Pro\B4244\_Rdy\_typ.dgn

STATE OF  
NORTH CAROLINA  
DEPT. OF TRANSPORTATION  
DIVISION OF HIGHWAYS  
RALEIGH, N.C.

ENGLISH DETAIL DRAWING FOR  
**ANCHORAGE FOR FRAMES**  
BRICK/CONCRETE/PRECAST CONCRETE

SHEET 1 OF 1  
**840D25**

STATE OF  
NORTH CAROLINA  
DEPT. OF TRANSPORTATION  
DIVISION OF HIGHWAYS  
RALEIGH, N.C.

ENGLISH DETAIL DRAWING FOR  
**ANCHORAGE FOR FRAMES**  
BRICK/CONCRETE/PRECAST CONCRETE

SHEET 1 OF 1  
**840D25**

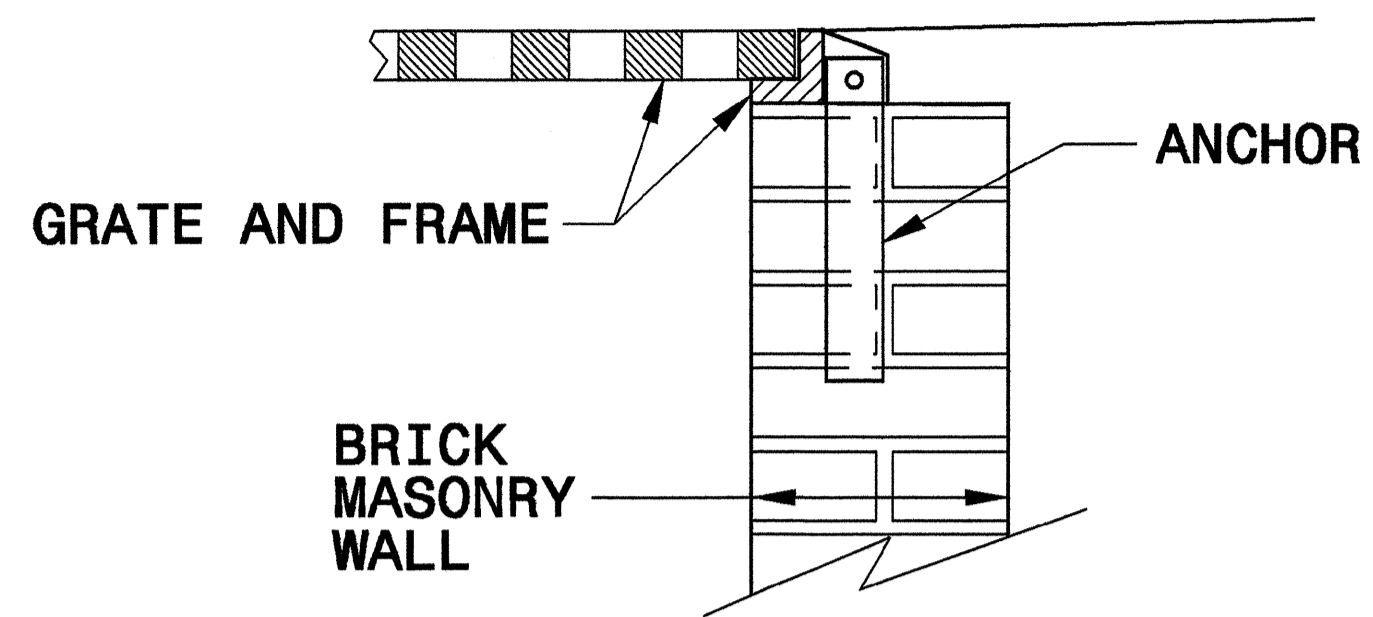

**BRICK MASONRY  
CONSTRUCTION**

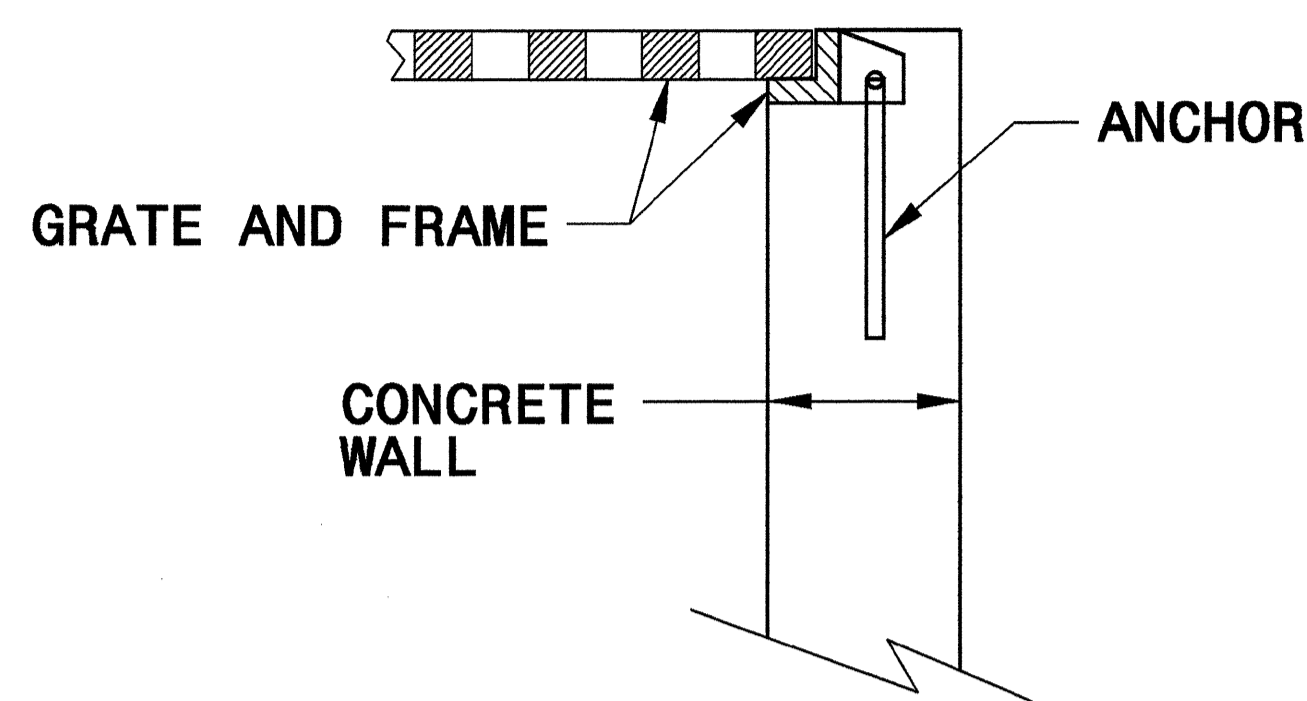

**CONCRETE  
CONSTRUCTION**

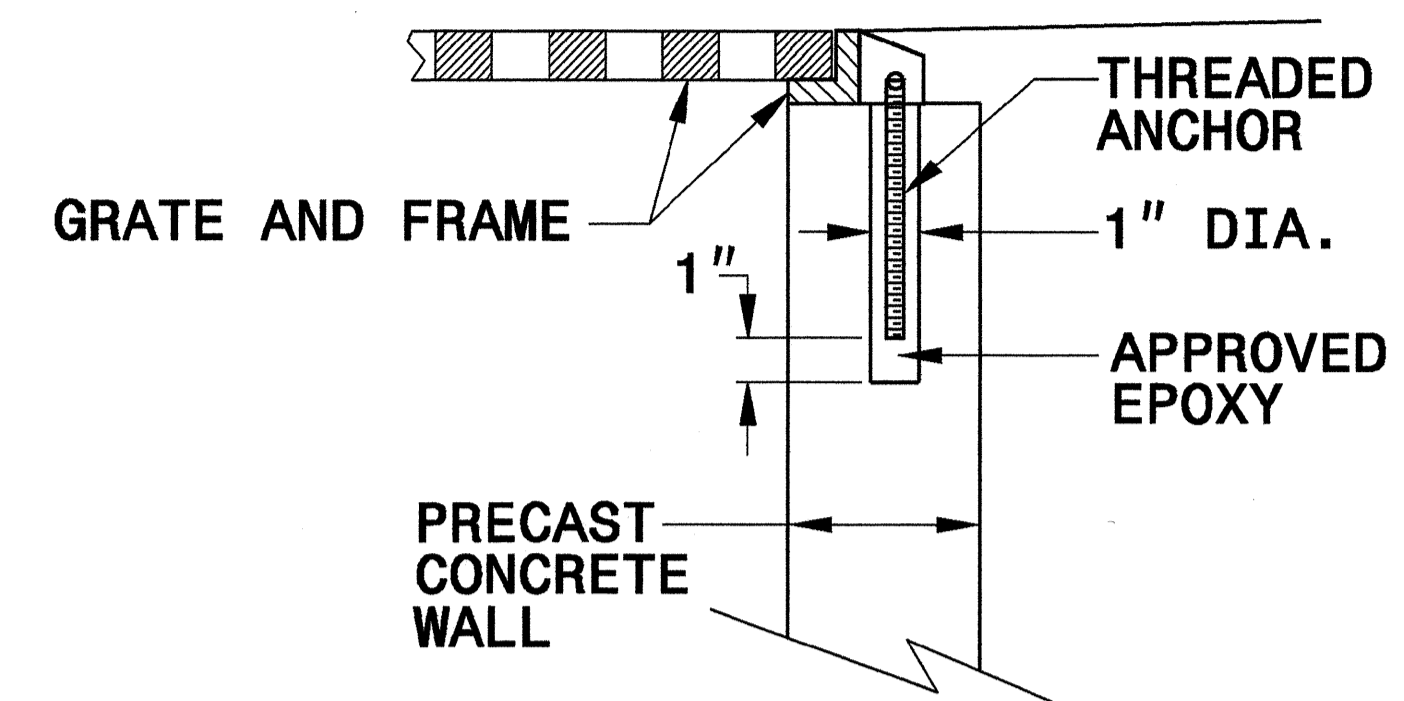

**PRECAST CONCRETE  
CONSTRUCTION**

**DETAIL SHOWING ANCHORAGE OF  
FRAME FOR GRATED DROP INLET**

NOTE:  
CONSTRUCT GRATED DROP INLET TO COINCIDE WITH NORMAL  
OR SUPERELEVATED SHOULDER OR PAVEMENT SLOPE.

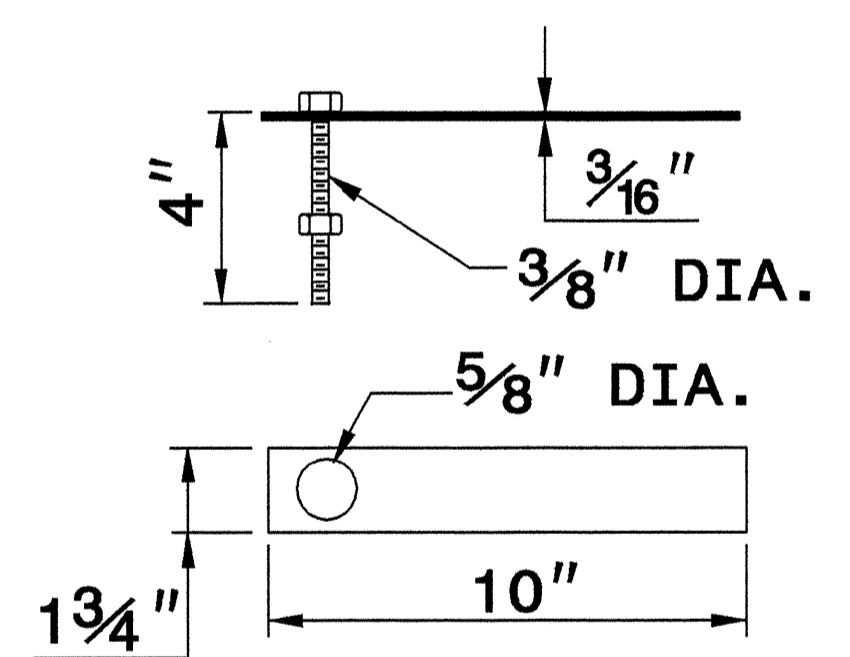

**MASONRY ANCHOR**  
3/8" DIA. BOLT WITH PLATE

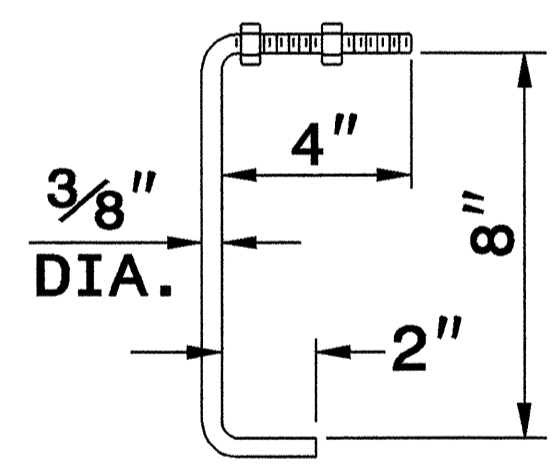

**CONCRETE ANCHOR**  
3/8" DIA. BENT BAR

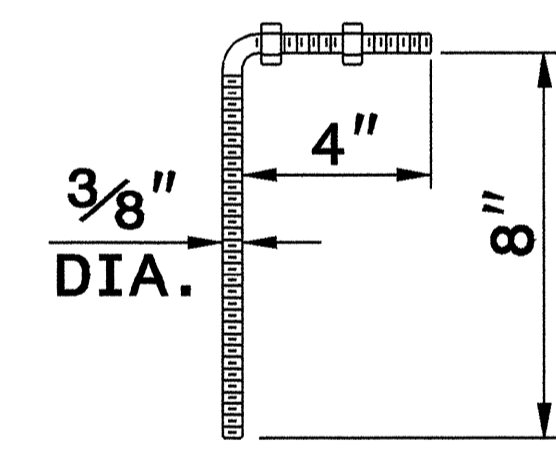

**PRECAST  
CONCRETE ANCHOR**  
3/8" DIA. BENT BAR

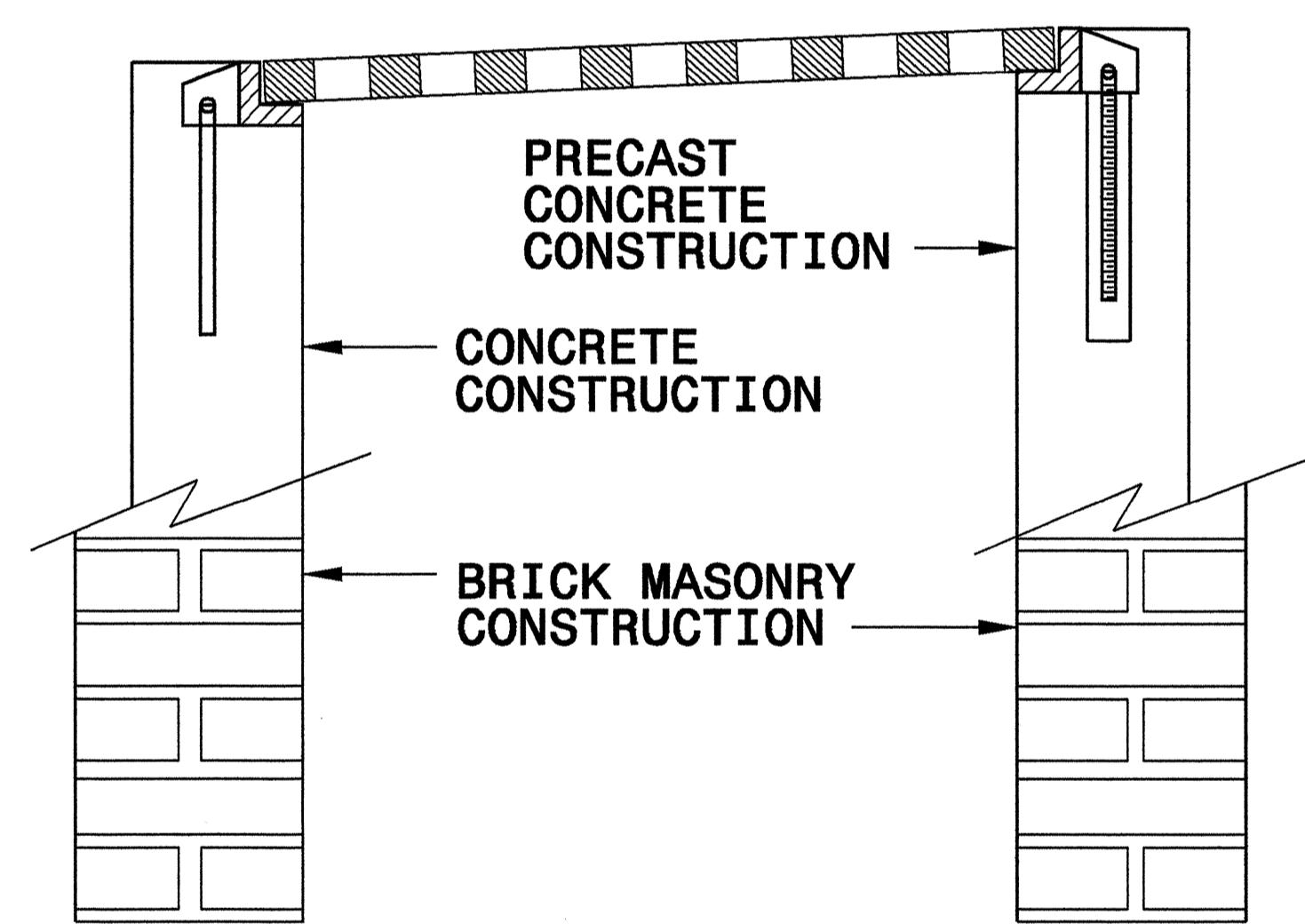

**FRAME AND GRATE INSTALLATION  
FOR NORMAL CROWN AND  
SUPERELEVATED SECTIONS**

27-SEP-2006 08:59  
 C:\cncr\std\stds\Special\_Details\stds\06\stds to Special\_Details\84025 Anchorage for Frames\0840d25.dgn  
 AT PS22293  
 ericward

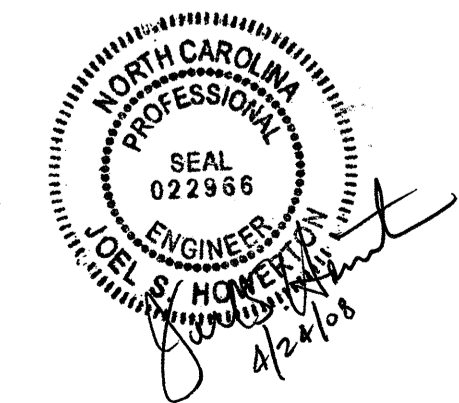

PROJECT SERVICES UNIT  
STANDARDS AND SPECIAL DESIGN  
Office 919-250-4128 FAX 919-250-4119

**SEE PLATE FOR TITLE**

ORIGINAL BY: 2006 STD 840.25 DATE: 07/18/06  
 MODIFIED BY: E.E. WARD DATE: 9/25/06  
 CHECKED BY: DATE:  
 FILE SPEC.:

COMPUTED BY: \_\_\_\_\_ DATE: \_\_\_\_\_  
 CHECKED BY: \_\_\_\_\_ DATE: \_\_\_\_\_

PROJECT REFERENCE NO. SHEET NO.  
 B-4244 3

STATE OF NORTH CAROLINA  
 DIVISION OF HIGHWAYS  
 ROADWAY SUMMARY OF QUANTITIES FOR CONTRACT - C201873

ItemNumber	Sec #	Quantity	Unit	Description
0000100000-N	800	Lump Sum		MOBILIZATION
0029000000-N	SP	Lump Sum		REINFORCED BRIDGE APPROACH FILL, STATION ***** (18+10.00)
0043000000-N	226	Lump Sum		GRADING
0050000000-E	226	1	ACR	SUPPLEMENTARY CLEARING & GRUB-BING
0057000000-E	226	200	CY	UNDERCUT EXCAVATION
0134000000-E	240	220	CY	DRAINAGE DITCH EXCAVATION
0195000000-E	265	500	CY	SELECT GRANULAR MATERIAL
0196000000-E	270	500	SY	FABRIC FOR SOIL STABILIZATION
0318000000-E	300	10	TON	FOUNDATION CONDITIONING MATERIAL, MINOR STRS
0344000000-E	310	48	LF	18" SIDE DRAIN PIPE
0708000000-E	310	32	LF	15" BIT COAT CS PIPE CULVERTS, TYPE B 0.064" THICK
0806000000-E	310	4	EA	15" BIT COAT CS PIPE ELBOWS, TYPE B 0.064" THICK
1220000000-E	545	100	TON	INCIDENTAL STONE BASE
1489000000-E	610	450	TON	ASPHALT CONC BASE COURSE, TYPE B25.0B
1498000000-E	610	275	TON	ASPHALT CONC INTERMEDIATE COURSE, TYPE 119.0B
1519000000-E	610	350	TON	ASPHALT CONC SURFACE COURSE, TYPE S9.5B
1560000000-E	620	55	TON	ASPHALT BINDER FOR PLANT MIX, GRADE PG 64-22
2000000000-N	806	8	EA	RIGHT OF WAY MARKERS
2286000000-N	840	2	EA	MASONRY DRAINAGE STRUCTURES
2367000000-N	840	2	EA	FRAME WITH TWO GRATES, STD 840.29
2556000000-E	846	70	LF	SHOULDER BERM GUTTER
3030000000-E	862	487.5	LF	STEEL BM GUARDRAIL
3045000000-E	862	50	LF	STEEL BM GUARDRAIL, SHOP CURVED
3150000000-N	862	5	EA	ADDITIONAL GUARDRAIL POSTS
3195000000-N	862	1	EA	GUARDRAIL ANCHOR UNITS, TYPE AT-1
3270000000-N	SP	3	EA	GUARDRAIL ANCHOR UNITS, TYPE 350
3317000000-N	862	4	EA	GUARDRAIL ANCHOR UNITS, TYPE B-77
3649000000-E	876	95	TON	RIP RAP, CLASS B
3656000000-E	876	365	SY	FILTER FABRIC FOR DRAINAGE
4400000000-E	1110	421	SF	WORK ZONE SIGNS (STATIONARY)
4405000000-E	1110	128	SF	WORK ZONE SIGNS (PORTABLE)
4410000000-E	1110	114	SF	WORK ZONE SIGNS (BARRICADE MOUNTED)
4435000000-N	1135	50	EA	CONES
4445000000-E	1145	64	LF	BARRICADES (TYPE III)
4450000000-N	1150	160	HR	FLAGGER
4810000000-E	1205	31,200	LF	PAINT PAVEMENT MARKING LINES (4")
4900000000-N	1251	14	EA	PERMANENT RAISED PAVEMENT MARKERS
6000000000-E	1605	225	LF	TEMPORARY SILT FENCE
6006000000-E	1610	75	TON	STONE FOR EROSION CONTROL, CLASS A
6009000000-E	1610	150	TON	STONE FOR EROSION CONTROL, CLASS B
6012000000-E	1610	30	TON	SEDIMENT CONTROL STONE
6015000000-E	1615	1.5	ACR	TEMPORARY MULCHING
6018000000-E	1620	100	LB	SEED FOR TEMPORARY SEEDING
6021000000-E	1620	1.25	TON	FERTILIZER FOR TEMPORARY SEEDING
6029000000-E	SP	275	LF	SAFETY FENCE
6030000000-E	1630	665	CY	SILT EXCAVATION
6036000000-E	1631	1,000	SY	MATTING FOR EROSION CONTROL
6037000000-E	SP	50	SY	COIR FIBER MAT
6038000000-E	SP	745	SY	PERMANENT SOIL REINFORCEMENT MAT

ItemNumber	Sec #	Quantity	Unit	Description
6042000000-E	1632	40	LF	1/4" HARDWARE CLOTH
6071030000-E	SP	260	LF	COIR FIBER BAFFLES
6071050000-E	SP	8	EA	*** SKIMMER (1-1/2")
6084000000-E	1660	2.5	ACR	SEEDING & MULCHING
6087000000-E	1660	1	ACR	MOWING
6090000000-E	1661	50	LB	SEED FOR REPAIR SEEDING
6093000000-E	1661	0.25	TON	FERTILIZER FOR REPAIR SEEDING
6096000000-E	1662	50	LB	SEED FOR SUPPLEMENTAL SEEDING
6108000000-E	1665	1	TON	FERTILIZER TOPDRESSING
6114000000-N	SP	2	HR	SPECIALIZED HAND MOWING
6117000000-N	SP	12	EA	RESPONSE FOR EROSION CONTROL

6/4/99

4/22/2008  
 C:\p\rdwy\Proj\4244\_Rdy.sum\_ear-thwork.dgn





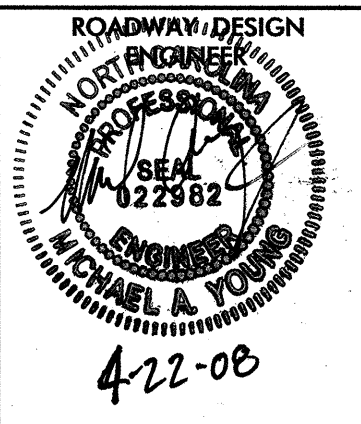
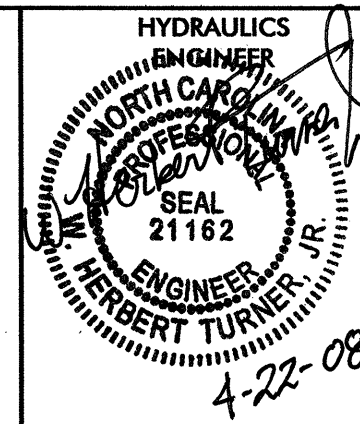

8/17/99  
 4/22/2008  
 C:\Roadway\Projects\B4244\_Rd\psh\_04.dgn

PROJECT REFERENCE NO. B-4244	SHEET NO. 4
R/W SHEET NO.	
ROADWAY DESIGN  MICHAEL A. YOUNG 4-22-08	HYDRAULICS  HERBERT TURNER 4-22-08

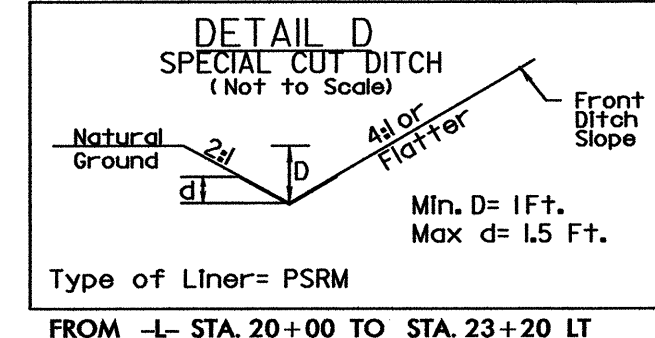
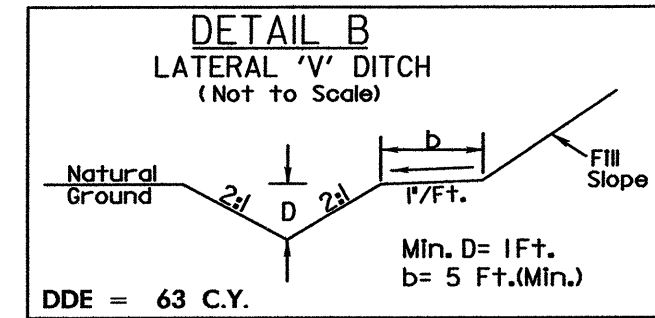
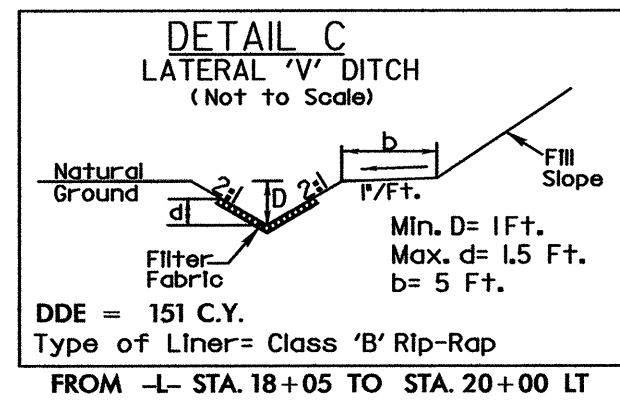

-L-  
 PI Sta 15+42.14  
 $\Delta = 0' 59' 15.8''$  (LT)  
 $D = 0' 28' 38.9''$   
 $L = 206.87'$   
 $T = 103.44'$   
 $R = 12,000.00'$   
 $e = \text{Existing}$   
 Runoff = See Plan

-L-  
 PI Sta 22+01.30  
 $\Delta = 0' 10' 14.5''$  (LT)  
 $D = 0' 17' 11.3''$   
 $L = 59.59'$   
 $T = 29.79'$   
 $R = 20,000.00'$   
 $e = \text{Existing}$   
 Runoff = See Plan

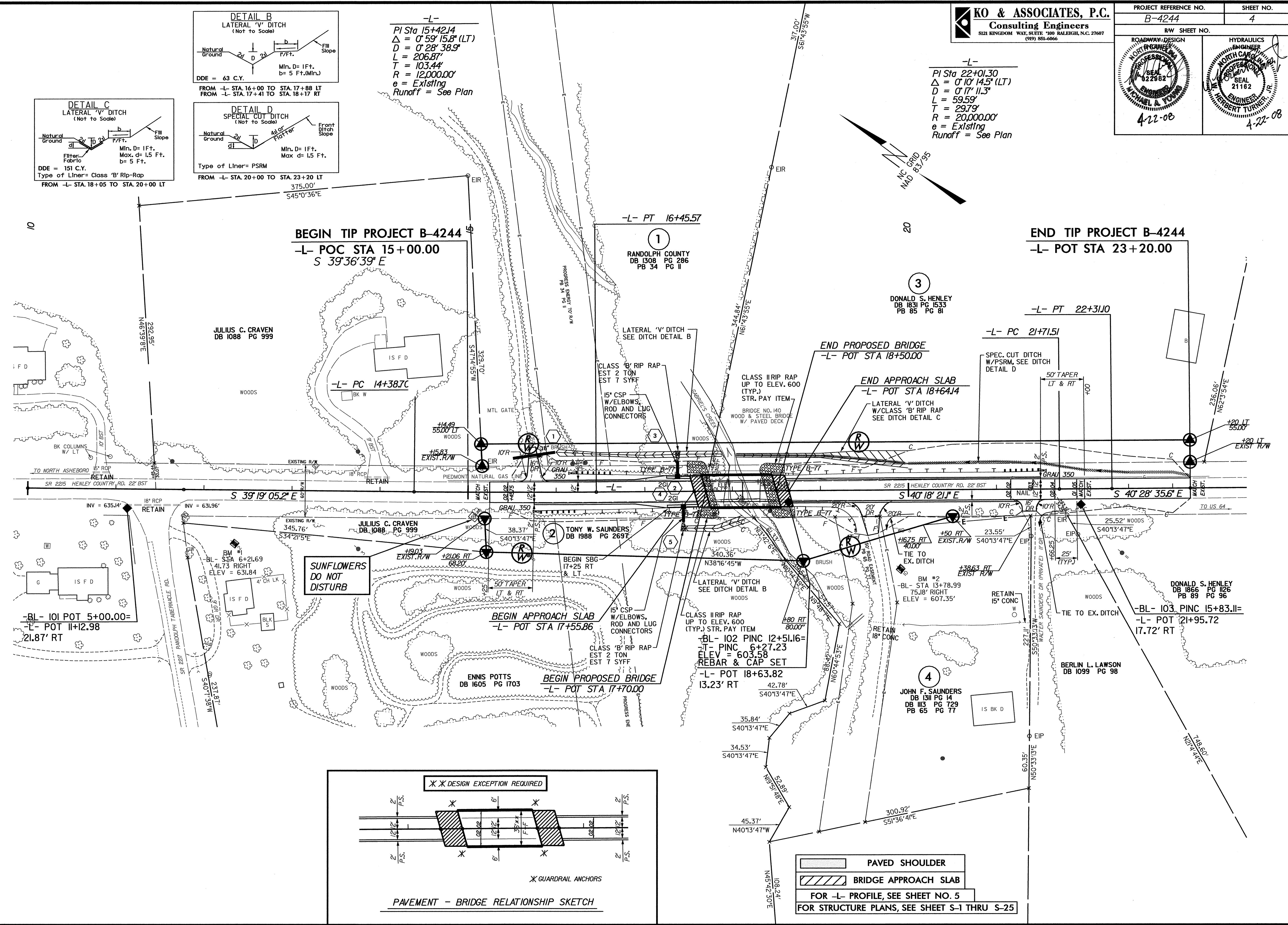

**SUNFLOWERS DO NOT DISTURB**

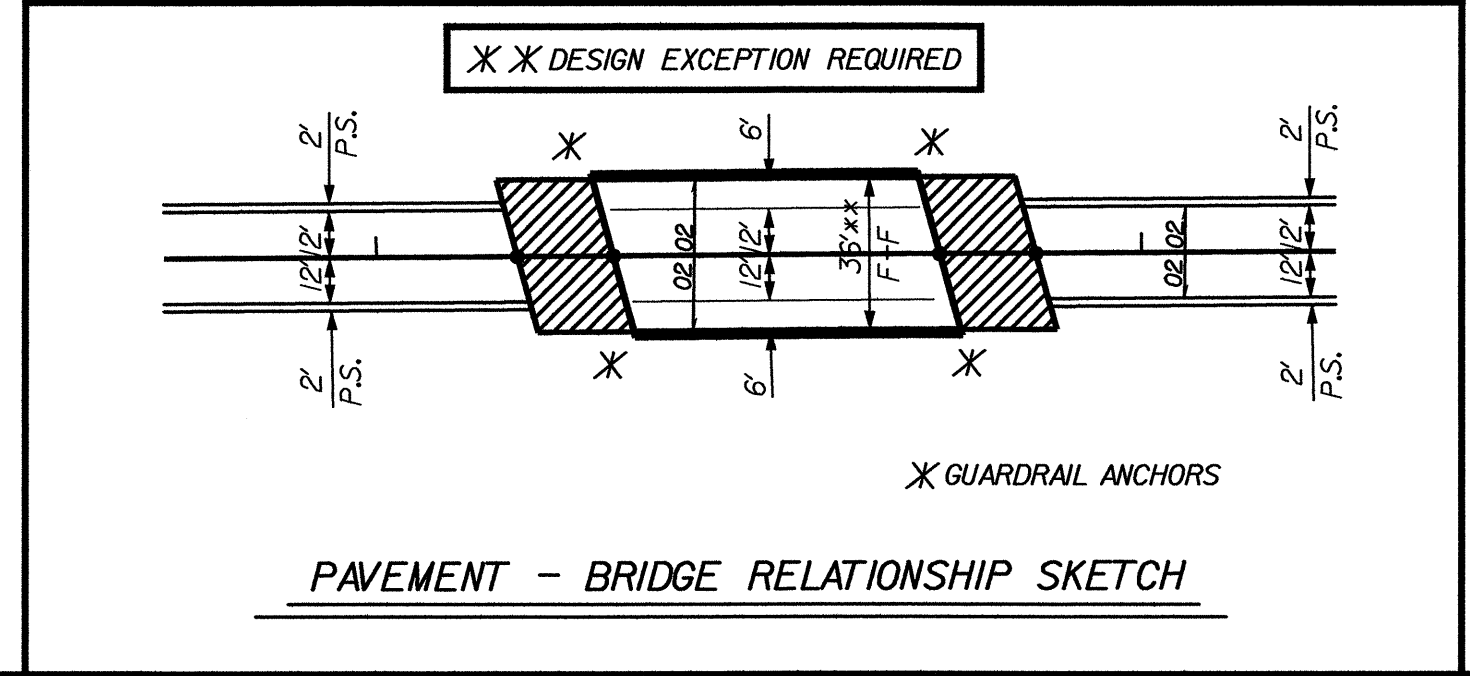

PAVED SHOULDER  
 BRIDGE APPROACH SLAB  
 FOR -L- PROFILE, SEE SHEET NO. 5  
 FOR STRUCTURE PLANS, SEE SHEET S-1 THRU S-25