

TIP PROJECT: B-2146

CONTRACT: C201785

See Sheet 1-A For Index of Sheets
See Sheet 1-B For Conventional Symbols

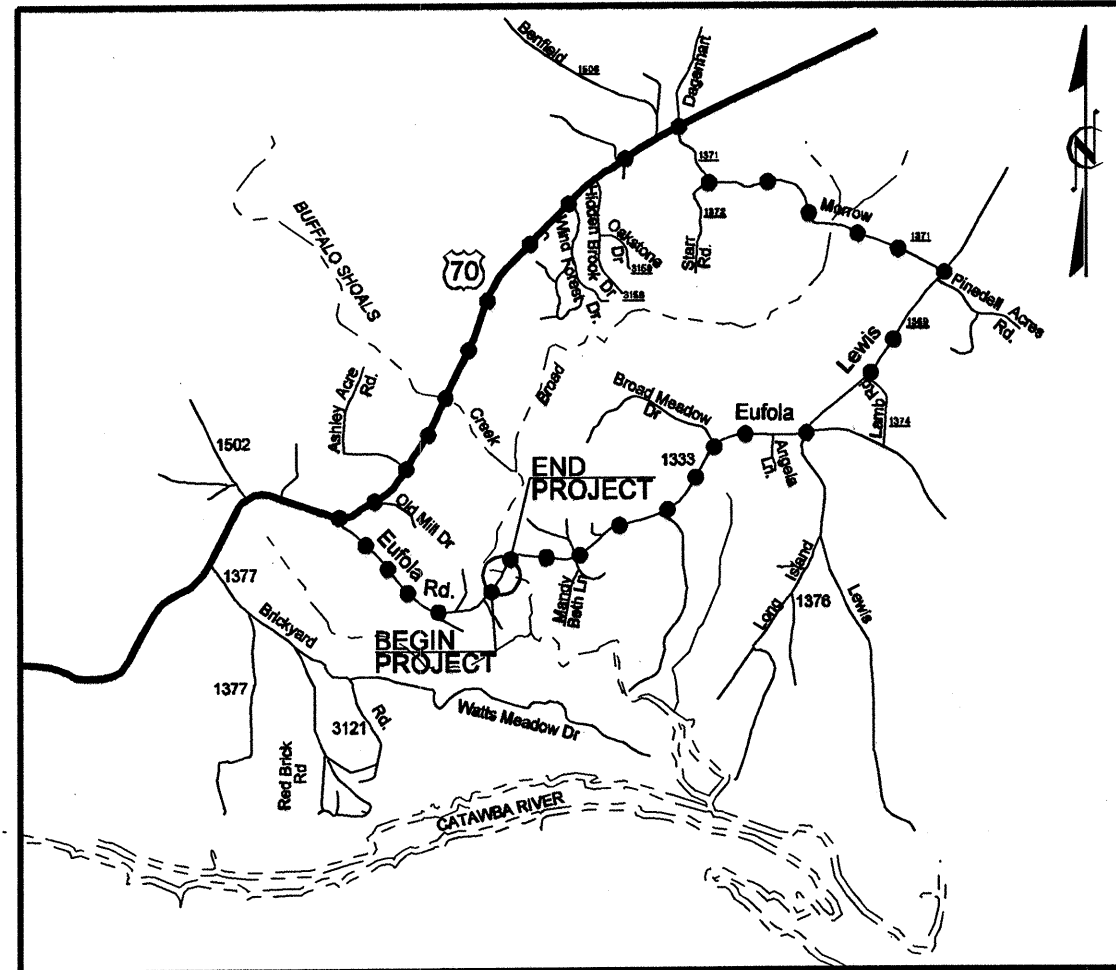

VICINITY MAP

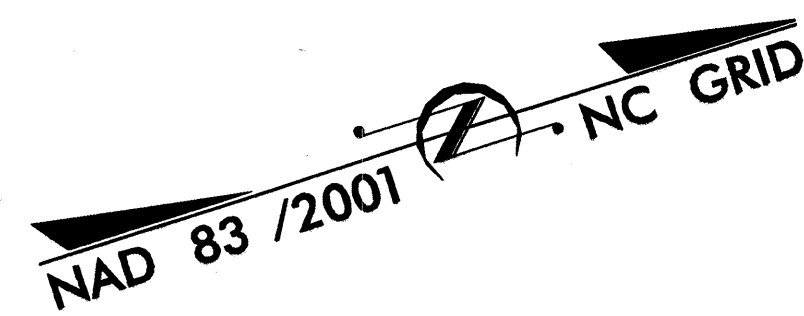
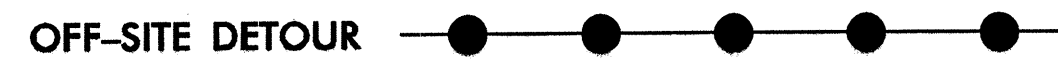

STATE OF NORTH CAROLINA
DIVISION OF HIGHWAYS

IREDELL COUNTY

**LOCATION: BRIDGE NO. 86 AND APPROACHES
ON SR 1333 (EUFOLA ROAD)
OVER BUFFALO SHOALS CREEK**

TYPE OF WORK: GRADING, PAVING, DRAINAGE, AND STRUCTURE

STATE	STATE PROJECT REFERENCE NO.	SHEET NO.	TOTAL SHEETS
N.C.	B-2146	1	
STATE PROJ. NO.	F.A. PROJ. NO.	DESCRIPTION	
32620.1.1	BRZ-1333(5)	P.E.	
32620.3.1	BRZ-1333(5)	UTIL. & RW	
32620.2.3	BRZ-1333(5)	CONST.	

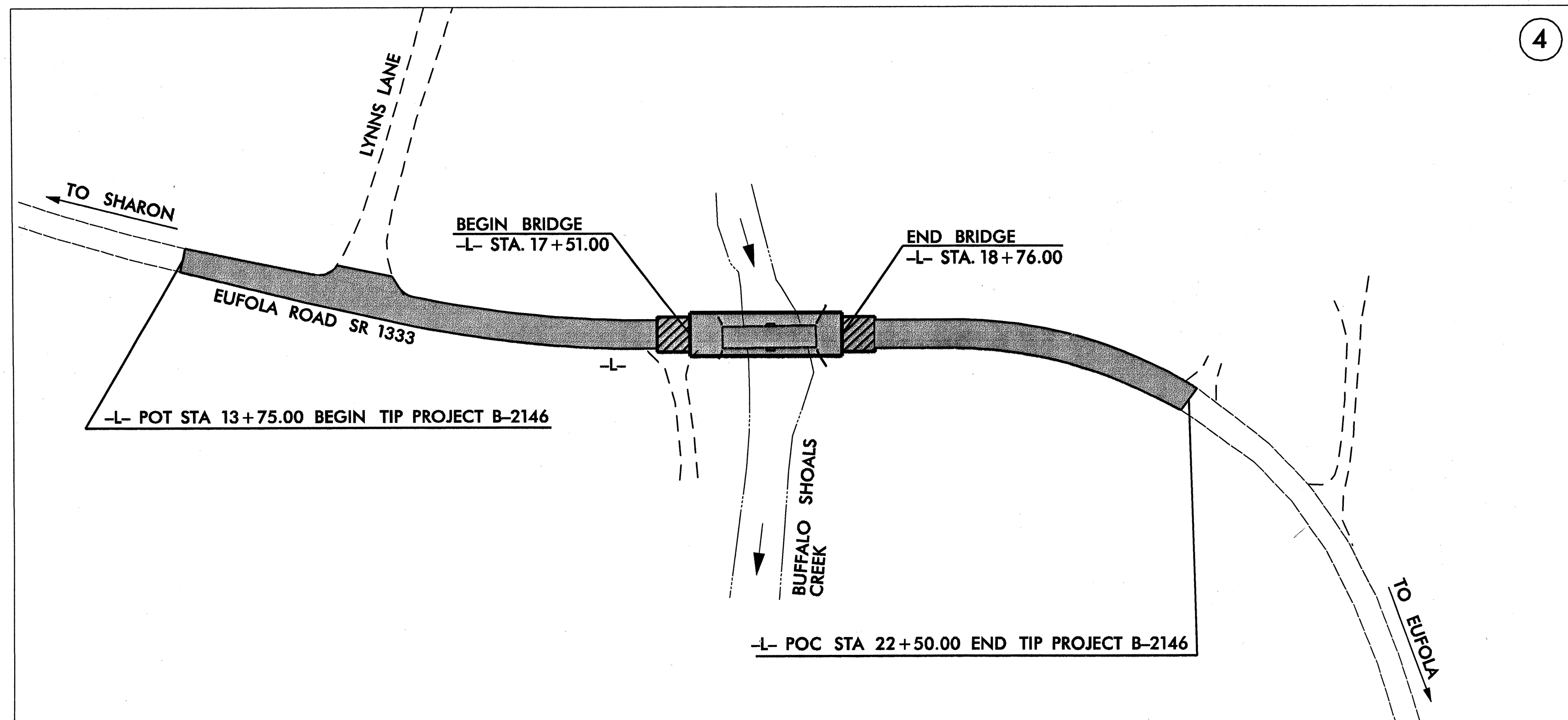

** DESIGN EXCEPTION FOR HORIZONTAL ALIGNMENT AND SAG VERTICAL CURVE REQUIRED.

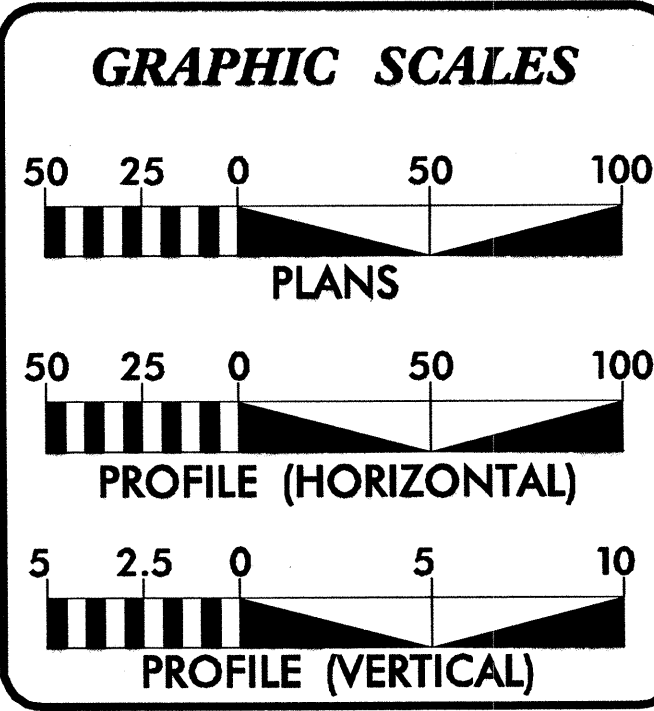

DESIGN DATA

ADT 2008 =	730
ADT 2028 =	1,048
DHV =	12 %
D =	60 %
T =	3 % *
** V =	60 MPH
* TTST 1 %	DUAL 2 %

PROJECT LENGTH

LENGTH ROADWAY TIP PROJECT B-2146	=	.142 mi
LENGTH STRUCTURE TIP PROJECT B-2146	=	.024 mi
TOTAL LENGTH OF TIP PROJECT B-2146	=	.166 mi

Prepared In the Office of:

RAMEY KEMP ASSOCIATES, INC.

2006 STANDARD SPECIFICATIONS

RIGHT OF WAY DATE:
JUNE 16, 2006

LETTING DATE:
JUNE 17, 2008

SCOTT CLARK, P.E.
PROJECT ENGINEER

MATTHEW COPPLE, P.E.
PROJECT DESIGN ENGINEER

HYDRAULICS ENGINEER

W. HENRY WELLS, JR.
P.E.
7/22/08

ROADWAY DESIGN ENGINEER

SCOTT CLARK
P.E.
3-14-08

M. SCOTT CLARK, P.E.

DIVISION OF HIGHWAYS
STATE OF NORTH CAROLINA

STATE HIGHWAY DESIGN ENGINEER

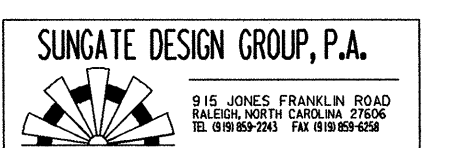

ROADWAY ENGLISH STANDARD DRAWINGS

The following Roadway Standards as appear in "Roadway Standard Drawings" Highway Design Branch - N. C. Department of Transportation - Raleigh, N. C., Dated January 18, 2006 are applicable to this project and by reference hereby are considered a part of these plans:

STD.NO.	TITLE
<u>DIVISION 2 - EARTHWORK</u>	
200.03	Method of Clearing - Method III
225.02	Guide for Grading Subgrade - Secondary and Local
225.04	Method of Obtaining Superelevation - Two Lane Pavement
<u>DIVISION 3 - PIPE CULVERTS</u>	
300.01	Method of Pipe Installation - Method 'A'
310.10	Driveway Pipe Construction
<u>DIVISION 4 - MAJOR STRUCTURES</u>	
422.10	Reinforced Bridge Approach Fills
<u>DIVISION 5 - SUBGRADE, BASES AND SHOULDERS</u>	
560.01	Method of Shoulder Construction - High Side of Superelevated Curve - Method I
<u>DIVISION 6 - ASPHALT BASES AND PAVEMENTS</u>	
654.01	Pavement Repairs
<u>DIVISION 8 - INCIDENTALS</u>	
840.29	Frames and Narrow Slot Flat Grates
840.35	Traffic Bearing Grated Drop Inlet - for Cast Iron Double Frame and Grates
840.46	Traffic Bearing Precast Drainage Structure
840.66	Drainage Structure Steps
846.01	Concrete Curb, Gutter and Curb & Gutter
846.04	Drop Inlet Installation in Shoulder Berm Gutter
862.01	Guardrail Placement
862.02	Guardrail Installation
862.03	Structure Anchor Units
862.04	Anchoring End of Guardrail - B-77 and B-83 Anchor Units
876.02	Guide for Rip Rap at Pipe Outlets

INDEX OF SHEETS

<u>SHEET NUMBER</u>	<u>SHEET</u>
1	TITLE SHEET
1-A	INDEX OF SHEETS, GENERAL NOTES, AND LIST OF STANDARD DRAWINGS
1-B	CONVENTIONAL SYMBOLS
1-C THRU 1-E	SURVEY CONTROL SHEET
2	PAVEMENT SCHEDULE, TYPICAL SECTIONS, AND STRUCTURE DETAIL
2-A	DETAIL OF ANCHORAGE FOR FRAMES
3	SUMMARY OF QUANTITIES
3-A	SUMMARY OF DRAINAGE QUANTITIES SUMMARY OF GUARDRAIL, EARTHWORK SUMMARY, AND ASPHALT PAVEMENT REMOVAL SUMMARY
4	PLAN SHEET
5	PROFILE SHEET
TCP-1 THRU TCP-3	TRAFFIC CONTROL PLANS
SD-1	SIGNING PLAN
EC-1 THRU EC-5	EROSION CONTROL PLANS
X-1	CROSS-SECTION SUMMARY
X-2 THRU X-10	CROSS-SECTIONS
S-1 THRU S-24	STRUCTURE PLANS

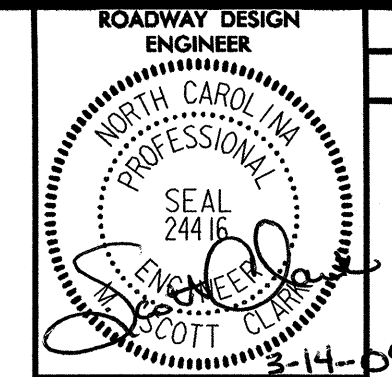

GENERAL NOTES: 2006 SPECIFICATIONS
EFFECTIVE: 7-18-06

GRADING AND SURFACING:

THE GRADE LINES SHOWN DENOTE THE FINISHED ELEVATION OF THE PROPOSED SURFACING AT GRADE POINTS SHOWN ON THE TYPICAL SECTIONS. GRADE LINES MAY BE ADJUSTED AT THEIR BEGINNING AND ENDING AND AT STRUCTURES AS DIRECTED BY THE ENGINEER IN ORDER TO SECURE A PROPER TIE-IN.

CLEARING:

CLEARING ON THIS PROJECT SHALL BE PERFORMED TO THE LIMITS ESTABLISHED BY METHOD III.

SUPERELEVATION:

ALL CURVES ON THIS PROJECT SHALL BE SUPERELEVATED IN ACCORDANCE WITH STD. NO. 225.04 USING THE RATE OF SUPERELEVATION AND RUNOFF SHOWN ON THE PLANS. SUPERELEVATION IS TO BE REVOLVED ABOUT THE GRADE POINTS SHOWN ON THE TYPICAL SECTIONS.

SHOULDER CONSTRUCTION:

ASPHALT, EARTH, AND CONCRETE SHOULDER CONSTRUCTION ON THE HIGH SIDE OF SUPERELEVATED CURVES SHALL BE IN ACCORDANCE WITH STD. NO. 560.01.

SIDE ROADS:

THE CONTRACTOR WILL BE REQUIRED TO DO ALL NECESSARY WORK TO PROVIDE SUITABLE CONNECTIONS WITH ALL ROADS, STREETS, AND DRIVES ENTERING THIS PROJECT. THIS WORK WILL BE PAID FOR AT THE CONTRACT UNIT PRICE FOR THE PARTICULAR ITEMS INVOLVED.

GUARDRAIL:

THE GUARDRAIL LOCATIONS SHOWN ON THE PLANS MAY BE ADJUSTED DURING CONSTRUCTION AS DIRECTED BY THE ENGINEER. THE CONTRACTOR SHOULD CONSULT WITH THE ENGINEER PRIOR TO ORDERING GUARDRAIL MATERIAL.

TEMPORARY SHORING:

SHORING REQUIRED FOR THE MAINTENANCE OF TRAFFIC WILL BE PAID FOR AS "EXTRA WORK" IN ACCORDANCE WITH SECTION 104-7.

END BENTS:

THE ENGINEER SHALL CHECK THE STRUCTURE END BENT PLANS, DETAILS, AND CROSS-SECTION PRIOR TO SETTING OF THE SLOPE STAKES FOR THE EMBANKMENT OR EXCAVATION APPROACHING A BRIDGE.

UTILITIES:

UTILITY OWNERS ON THIS PROJECT ARE: DUKE POWER.
ANY RELOCATION OF EXISTING UTILITIES WILL BE ACCOMPLISHED BY OTHERS.

RIGHT-OF-WAY MARKERS:

ALL RIGHT-OF-WAY MARKERS ON THIS PROJECT SHALL BE PLACED BY OTHERS.

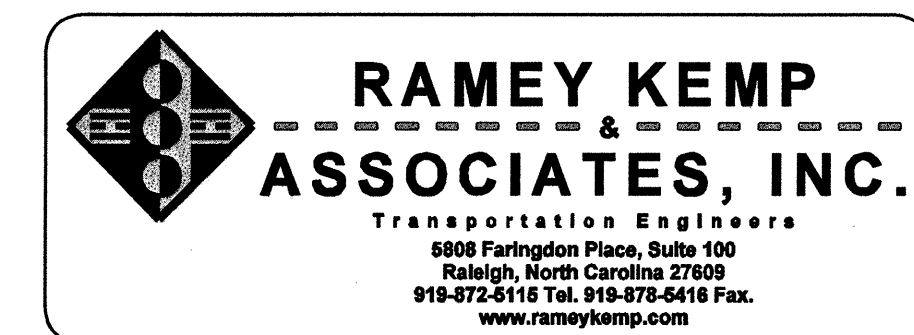

Note: Not to Scale

*S.U.E. = Subsurface Utility Engineering













STATE OF NORTH CAROLINA
DIVISION OF HIGHWAYS

PROJECT REFERENCE NO. B-2146 SHEET NO. 1-B













CONVENTIONAL PLAN SHEET SYMBOLS











BOUNDARIES AND PROPERTY:

State Line	_____
County Line	_____
Township Line	_____
City Line	_____
Reservation Line	_____
Property Line	_____
Existing Iron Pin	_____ 
Property Corner	_____ 
Property Monument	_____ 
Parcel/Sequence Number	_____ 
Existing Fence Line	_____ 
Proposed Woven Wire Fence	_____ 
Proposed Chain Link Fence	_____ 
Proposed Barbed Wire Fence	_____ 
Existing Wetland Boundary	_____ 
Proposed Wetland Boundary	_____ 
Existing Endangered Animal Boundary	_____ 
Existing Endangered Plant Boundary	_____ 





BUILDINGS AND OTHER CULTURE:

Gas Pump Vent or U/G Tank Cap	_____ 
Sign	_____ 
Well	_____ 
Small Mine	_____ 
Foundation	_____ 
Area Outline	_____ 
Cemetery	_____ 
Building	_____ 
School	_____ 
Church	_____ 
Dam	_____ 



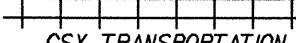

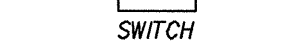







HYDROLOGY:

Stream or Body of Water	_____
Hydro, Pool or Reservoir	_____ 
Jurisdictional Stream	_____ 
Buffer Zone 1	_____ 
Buffer Zone 2	_____ 
Flow Arrow	_____ 
Disappearing Stream	_____ 
Spring	_____ 
Wetlands	_____ 
Proposed Lateral, Tail, Head Ditch	_____ 
False Sump	_____ 











RAILROADS:

Standard Gauge	_____ 
RR Signal Milepost	_____ 
Switch	_____ 
RR Abandoned	_____ 
RR Dismantled	_____ 







RIGHT OF WAY:

Baseline Control Point	_____ 
Existing Right of Way Marker	_____ 
Existing Right of Way Line	_____ 
Proposed Right of Way Line	_____ 
Proposed Right of Way Line with Iron Pin and Cap Marker	_____ 
Proposed Right of Way Line with Concrete or Granite Marker	_____ 
Existing Control of Access	_____ 
Proposed Control of Access	_____ 
Existing Easement Line	_____ 
Proposed Temporary Construction Easement	_____ 
Proposed Temporary Drainage Easement	_____ 
Proposed Permanent Drainage Easement	_____ 
Proposed Permanent Utility Easement	_____ 







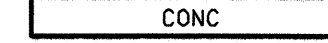

ROADS AND RELATED FEATURES:

Existing Edge of Pavement	_____
Existing Curb	_____
Proposed Slope Stakes Cut	_____ 
Proposed Slope Stakes Fill	_____ 
Proposed Wheel Chair Ramp	_____ 
Proposed Wheel Chair Ramp Curb Cut	_____ 
Curb Cut for Future Wheel Chair Ramp	_____ 
Existing Metal Guardrail	_____ 
Proposed Guardrail	_____ 
Existing Cable Guiderail	_____ 
Proposed Cable Guiderail	_____ 
Equality Symbol	_____ 
Pavement Removal	_____ 

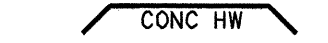
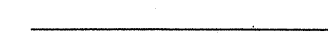

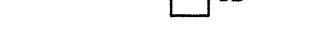





VEGETATION:

Single Tree	_____ 
Single Shrub	_____ 
Hedge	_____ 
Woods Line	_____ 
Orchard	_____ 
Vineyard	_____ 



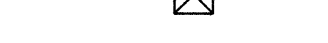
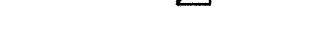







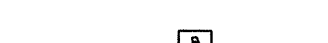
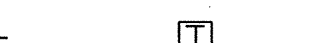

EXISTING STRUCTURES:

MAJOR:	
Bridge, Tunnel or Box Culvert	_____ 
Bridge Wing Wall, Head Wall and End Wall	_____ 
MINOR:	
Head and End Wall	_____ 
Pipe Culvert	_____ 
Footbridge	_____ 
Drainage Box: Catch Basin, DI or JB	_____ 
Paved Ditch Gutter	_____ 
Storm Sewer Manhole	_____ 
Storm Sewer	_____ 

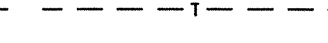





UTILITIES:

POWER:	
Existing Power Pole	_____ 
Proposed Power Pole	_____ 
Existing Joint Use Pole	_____ 
Proposed Joint Use Pole	_____ 
Power Manhole	_____ 
Power Line Tower	_____ 
Power Transformer	_____ 
U/G Power Cable Hand Hole	_____ 
H-Frame Pole	_____ 
Recorded U/G Power Line	_____ 
Designated U/G Power Line (S.U.E.*)	_____ 









TELEPHONE:

Existing Telephone Pole	_____ 
Proposed Telephone Pole	_____ 
Telephone Manhole	_____ 
Telephone Booth	_____ 
Telephone Pedestal	_____ 
Telephone Cell Tower	_____ 
U/G Telephone Cable Hand Hole	_____ 
Recorded U/G Telephone Cable	_____ 
Designated U/G Telephone Cable (S.U.E.*)	_____ 
Recorded U/G Telephone Conduit	_____ 
Designated U/G Telephone Conduit (S.U.E.*)	_____ 
Recorded U/G Fiber Optics Cable	_____ 
Designated U/G Fiber Optics Cable (S.U.E.*)	_____ 





WATER:

Water Manhole	_____ 
Water Meter	_____ 
Water Valve	_____ 
Water Hydrant	_____ 
Recorded U/G Water Line	_____ 
Designated U/G Water Line (S.U.E.*)	_____ 
Above Ground Water Line	_____ 







TV:

TV Satellite Dish	_____ 
TV Pedestal	_____ 
TV Tower	_____ 
U/G TV Cable Hand Hole	_____ 
Recorded U/G TV Cable	_____ 
Designated U/G TV Cable (S.U.E.*)	_____ 
Recorded U/G Fiber Optic Cable	_____ 
Designated U/G Fiber Optic Cable (S.U.E.*)	_____ 











GAS:

Gas Valve	_____ 
Gas Meter	_____ 
Recorded U/G Gas Line	_____ 
Designated U/G Gas Line (S.U.E.*)	_____ 
Above Ground Gas Line	_____ 

SANITARY SEWER:

Sanitary Sewer Manhole	_____ 
Sanitary Sewer Cleanout	_____ 
U/G Sanitary Sewer Line	_____ 
Above Ground Sanitary Sewer	_____ 
Recorded SS Forced Main Line	_____ 
Designated SS Forced Main Line (S.U.E.*)	_____ 

MISCELLANEOUS:

Utility Pole	_____ 
Utility Pole with Base	_____ 
Utility Located Object	_____ 
Utility Traffic Signal Box	_____ 
Utility Unknown U/G Line	_____ 
U/G Tank; Water, Gas, Oil	_____ 
A/G Tank; Water, Gas, Oil	_____ 
U/G Test Hole (S.U.E.*)	_____ 
Abandoned According to Utility Records	_____ 
End of Information	_____ 

SURVEY CONTROL SHEET B-2146

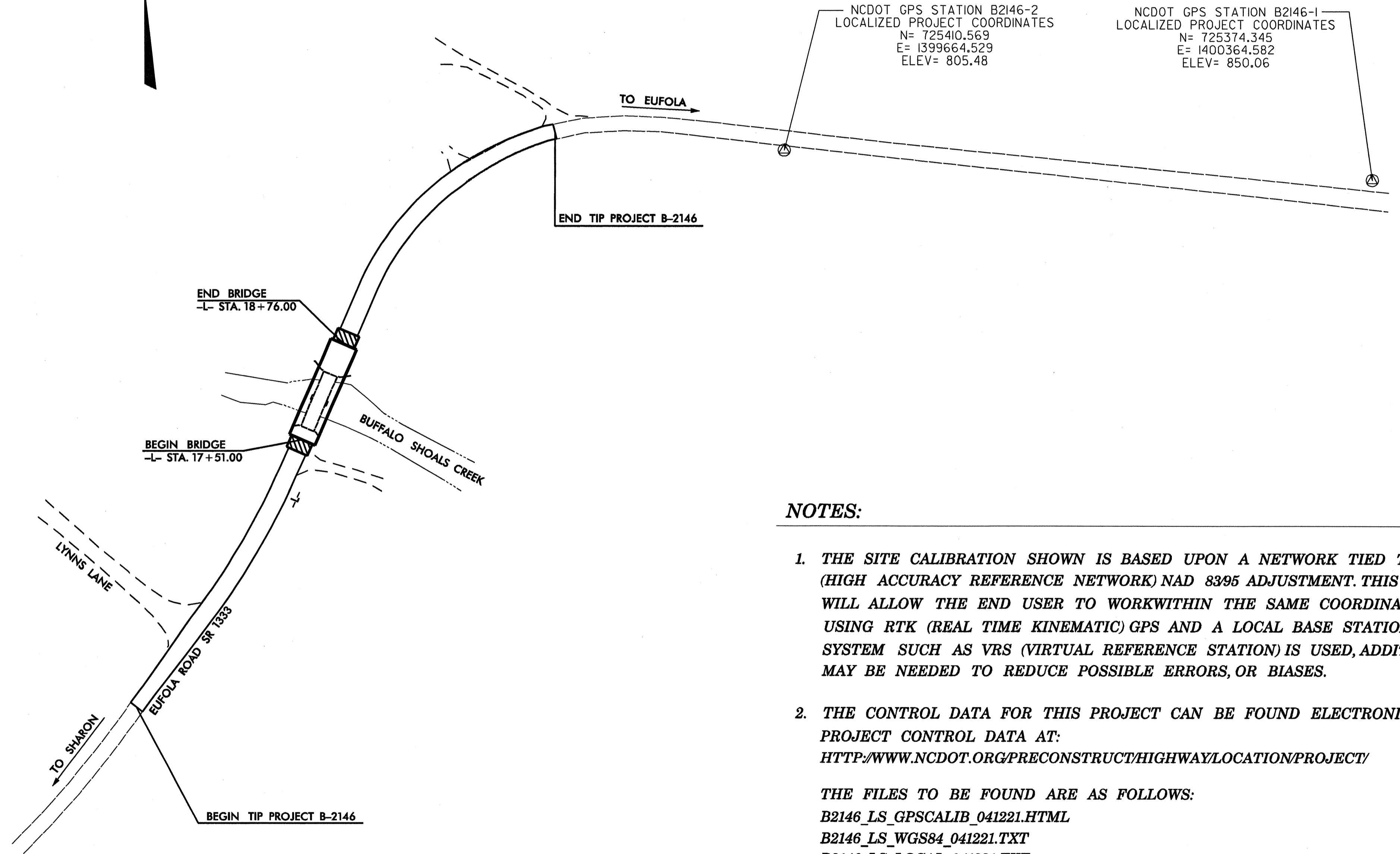
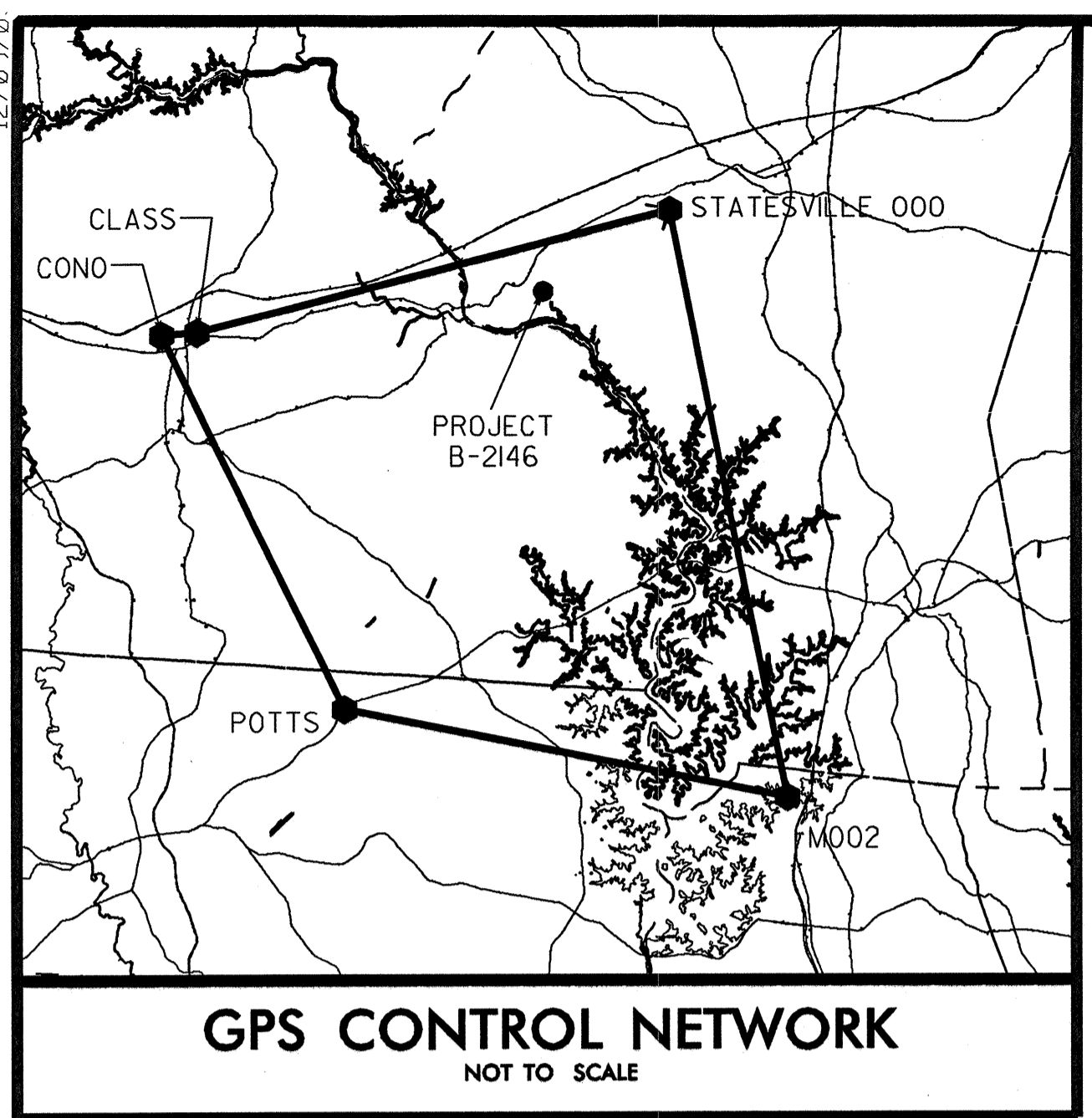

NOTES:

1. THE SITE CALIBRATION SHOWN IS BASED UPON A NETWORK TIED TO THE HARN (HIGH ACCURACY REFERENCE NETWORK) NAD 8395 ADJUSTMENT. THIS CALIBRATION WILL ALLOW THE END USER TO WORK WITHIN THE SAME COORDINATE SYSTEM WHEN USING RTK (REAL TIME KINEMATIC) GPS AND A LOCAL BASE STATION. IF ANOTHER SYSTEM SUCH AS VRS (VIRTUAL REFERENCE STATION) IS USED, ADDITIONAL FIELD TIES MAY BE NEEDED TO REDUCE POSSIBLE ERRORS, OR BIASES.
2. THE CONTROL DATA FOR THIS PROJECT CAN BE FOUND ELECTRONICALLY BY SELECTING PROJECT CONTROL DATA AT:
[HTTP://WWW.NCDOT.ORG/PRECONSTRUCT/HIGHWAY/LOCATION/PROJECT/](http://www.ncdot.org/preconstruct/highway/location/project/)

THE FILES TO BE FOUND ARE AS FOLLOWS:
 B2146_LS_GPSCALIB_041221.HTML
 B2146_LS_WGS84_041221.TXT
 B2146_LS_LOCAL_041221.TXT
 B2146_LS_CONTROL_050819.TXT

THE WGS84 AND LOCAL FILES ARE COMMA DELIMITED AND CAN BE USED TO REPRODUCE THE SITE CALIBRATION FOR THE END USER'S GPS EQUIPMENT. IF FURTHER INFORMATION IS NEEDED, PLEASE CONTACT THE LOCATION AND SURVEYS UNIT.

⊙ INDICATES GEODETIC CONTROL MONUMENTS USED OR SET FOR HORIZONTAL PROJECT CONTROL BY THE NCDOT LOCATION AND SURVEYS UNIT.
 PROJECT CONTROL ESTABLISHED USING GLOBAL POSITIONING SYSTEM.
 NETWORK ESTABLISHED FROM EXISTING HARN MONUMENTATION
 SEE GPS CALIBRATION SHEET FOR HORIZONTAL AND VERTICAL COORDINATE VALUES.

DATUM DESCRIPTION
 THE LOCALIZED COORDINATE SYSTEM DEVELOPED FOR THIS PROJECT IS BASED ON THE STATE PLANE COORDINATES ESTABLISHED BY NCDOT FOR MONUMENT "B2146-1"
 WITH NAD 1983/2001 STATE PLANE GRID COORDINATES OF
 NORTHING: 725374.345(ft) EASTING: 1400364.582(ft)
 THE AVERAGE COMBINED GRID FACTOR USED ON THIS PROJECT (GROUND TO GRID) IS: 0.999872000
 THE N.C. LAMBERT GRID BEARING AND LOCALIZED HORIZONTAL GROUND DISTANCE FROM "B2146-1" TO -L- PT STATION 13+54.00 IS
 S 66°27'17.5" W 1618.850'
 ALL LINEAR DIMENSIONS ARE LOCALIZED HORIZONTAL DISTANCES
 VERTICAL DATUM USED IS NAVD 88

NOTE: DRAWING NOT TO SCALE

12/09/01
 CLASS
 CONO
 STATESVILLE 000
 PROJECT B-2146
 POTTS
 M002
 GPS CONTROL NETWORK
 NOT TO SCALE
 NC GRID
 NAD 83/2001
 TO EUFOLA
 END TIP PROJECT B-2146
 END BRIDGE
 STA. 18+76.00
 BEGIN BRIDGE
 STA. 17+51.00
 BUFFALO SHOALS CREEK
 TO SHARON
 EUFOLA ROAD SR 1233
 BEGIN TIP PROJECT B-2146
 LYNN LANE
 NCDOT GPS STATION B2146-2
 LOCALIZED PROJECT COORDINATES
 N= 725410.569
 E= 1399664.529
 ELEV= 805.48
 NCDOT GPS STATION B2146-1
 LOCALIZED PROJECT COORDINATES
 N= 725374.345
 E= 1400364.582
 ELEV= 850.06
 NOTES:
 1. THE SITE CALIBRATION SHOWN IS BASED UPON A NETWORK TIED TO THE HARN (HIGH ACCURACY REFERENCE NETWORK) NAD 8395 ADJUSTMENT. THIS CALIBRATION WILL ALLOW THE END USER TO WORK WITHIN THE SAME COORDINATE SYSTEM WHEN USING RTK (REAL TIME KINEMATIC) GPS AND A LOCAL BASE STATION. IF ANOTHER SYSTEM SUCH AS VRS (VIRTUAL REFERENCE STATION) IS USED, ADDITIONAL FIELD TIES MAY BE NEEDED TO REDUCE POSSIBLE ERRORS, OR BIASES.
 2. THE CONTROL DATA FOR THIS PROJECT CAN BE FOUND ELECTRONICALLY BY SELECTING PROJECT CONTROL DATA AT:
 HTTP://WWW.NCDOT.ORG/PRECONSTRUCT/HIGHWAY/LOCATION/PROJECT/
 THE FILES TO BE FOUND ARE AS FOLLOWS:
 B2146_LS_GPSCALIB_041221.HTML
 B2146_LS_WGS84_041221.TXT
 B2146_LS_LOCAL_041221.TXT
 B2146_LS_CONTROL_050819.TXT
 THE WGS84 AND LOCAL FILES ARE COMMA DELIMITED AND CAN BE USED TO REPRODUCE THE SITE CALIBRATION FOR THE END USER'S GPS EQUIPMENT. IF FURTHER INFORMATION IS NEEDED, PLEASE CONTACT THE LOCATION AND SURVEYS UNIT.
 ⊙ INDICATES GEODETIC CONTROL MONUMENTS USED OR SET FOR HORIZONTAL PROJECT CONTROL BY THE NCDOT LOCATION AND SURVEYS UNIT.
 PROJECT CONTROL ESTABLISHED USING GLOBAL POSITIONING SYSTEM.
 NETWORK ESTABLISHED FROM EXISTING HARN MONUMENTATION
 SEE GPS CALIBRATION SHEET FOR HORIZONTAL AND VERTICAL COORDINATE VALUES.
 DATUM DESCRIPTION
 THE LOCALIZED COORDINATE SYSTEM DEVELOPED FOR THIS PROJECT IS BASED ON THE STATE PLANE COORDINATES ESTABLISHED BY NCDOT FOR MONUMENT "B2146-1"
 WITH NAD 1983/2001 STATE PLANE GRID COORDINATES OF
 NORTHING: 725374.345(ft) EASTING: 1400364.582(ft)
 THE AVERAGE COMBINED GRID FACTOR USED ON THIS PROJECT (GROUND TO GRID) IS: 0.999872000
 THE N.C. LAMBERT GRID BEARING AND LOCALIZED HORIZONTAL GROUND DISTANCE FROM "B2146-1" TO -L- PT STATION 13+54.00 IS
 S 66°27'17.5" W 1618.850'
 ALL LINEAR DIMENSIONS ARE LOCALIZED HORIZONTAL DISTANCES
 VERTICAL DATUM USED IS NAVD 88
 NOTE: DRAWING NOT TO SCALE

SURVEY CONTROL SHEET B-2146

PROJECT REFERENCE NO. 32620.1.1	SHEET NO. 1-E
Location and Surveys	

•GPS CALIBRATION REPORT•

PROJECT : B2146-Z

TIP NUMBER B-2146
 USER NAME JJEFFREYS DATE & TIME 10:42:34 AM 12/21/2004
 COORDINATE SYSTEM US STATE PLANE 1983(AT GROUND) ZONE NORTH CAROLINA 3200
 HORIZONTAL DATUM NAD 1983 (CONUS)
 VERTICAL DATUM NAVD 88 GEOID MODEL GEOID03 (CONUS) NC SUB GRID
 COORDINATE UNITS US SURVEY FEET
 DISTANCE UNITS US SURVEY FEET
 HEIGHT UNITS US SURVEY FEET

•LOCAL SITE INFORMATION•

LOCALIZED AROUND B2146-1
 LATITUDE 35°43'34.69546"N
 LONGITUDE 81°01'13.63158"W
 SITE SCALE FACTOR 1.0001280164
 HEIGHT ?

THE NORTH CAROLINA DEPARTMENT OF TRANSPORTATION USES A LOCALIZED COORDINATE SYSTEM WHICH IS VERY SIMILAR TO NORTH CAROLINA ZONE 3200 FROM WHICH IT IS DERIVED. PLEASE TAKE CARE IN UTILIZING THESE COORDINATES TO ELIMINATE CONFUSION OF THE TWO SYSTEMS. THIS FILE IS TO AID IN THE USE OF REAL TIME KINEMATIC (RTK) GPS DURING CONSTRUCTION LAYOUT.

•DATUM TRANSFORMATION PARAMETERS•

DATUM TRANSFORMATION COMPUTATION NOT REQUESTED

•UPDATED DEFAULT PROJECTION (TRANSVERSE MERCATOR) DEFINITION•

UPDATED DEFAULT PROJECTION NOT REQUESTED

•HORIZONTAL ADJUSTMENT PARAMETERS•

•NORTHING COORDINATE OF ROTATION CENTER• 703618.399SFT
 •EASTING COORDINATE OF ROTATION CENTER• 1386912.348SFT
 •ROTATION ABOUT THE CENTER POINT• 0.00'00"
 •TRANSLATION NORTH• 0.009SFT
 •TRANSLATION EAST• -0.004SFT
 •SCALE FACTOR• 1.00000050

•VERTICAL ADJUSTMENT PARAMETERS•

•NORTHING COORDINATE OF ORIGIN POINT• 718113.853SFT
 •EASTING COORDINATE OF ORIGIN POINT• 1336919.353SFT
 •VERTICAL SEPARATION AT ORIGIN• -0.005SFT
 •SLOPE NORTH• -1.633PPM
 •SLOPE EAST• -2.308PPM

•GEOID MODEL DEFINITION•

GEOID03 (CONUS) NC SUB GRID

•RESIDUAL DIFFERENCES BETWEEN GPS (WGS84) AND LOCAL COORDINATES•

•SUMMARY•

	MAXIMUM ERROR	ROOT MEAN SQUARE ERROR	POINT
HORIZONTAL	0.042SFT	0.008	M 002 GPS
VERTICAL	0.233SFT	0.038	STATESVILLE 000 GPS
THREE-DIMENSIONAL	0.234SFT	0.039	STATESVILLE 000 GPS

•POINT RESIDUALS•

WGS84 COORDINATES	CALCULATED POINT FOR DISPLAY ONLY	LOCAL COORDINATES
POINT CONO PHASE CTR	NORTHING 718113.853SFT	POINT CONO PHASE CTR
LATITUDE 35°42'09.46858"N	EASTING 1336919.353SFT	NORTHING 718113.865SFT
LONGITUDE 81°14'00.90073"W	ELEVATION 989.494SFT	EASTING 1336919.336SFT
HEIGHT 884.372SFT	HORZ ERROR 0.021SFT	ELEVATION 989.499SFT
	VERT ERROR 0.005SFT	UTILIZED HORZ AND VERT
	3D ERROR 0.022SFT	QUALITY CONTROL QUALITY
POINT CLASS GPS	NORTHING 718619.761SFT	POINT CLASS
LATITUDE 35°42'15.74501"N	EASTING 1342673.177SFT	NORTHING 718619.766SFT
LONGITUDE 81°12'51.29467"W	ELEVATION 1048.623SFT	EASTING 1342673.205SFT
HEIGHT 943.558SFT	HORZ ERROR 0.029SFT	ELEVATION 1048.653SFT
	VERT ERROR 0.030SFT	UTILIZED HORZ AND VERT
	3D ERROR 0.041SFT	QUALITY CONTROL QUALITY
POINT STATESVILLE 000	NORTHING 738745.074SFT	POINT STATESVILLE 000
LATITUDE 35°45'50.97233"N	EASTING 1420980.216SFT	NORTHING 738745.051SFT
LONGITUDE 80°57'06.84805"W	ELEVATION 959.378SFT	EASTING 1420980.200SFT
HEIGHT 854.572SFT	HORZ ERROR 0.028SFT	ELEVATION 959.611SFT
	VERT ERROR 0.233SFT	UTILIZED HORZ AND VERT
	3D ERROR 0.234SFT	QUALITY CONTROL QUALITY

POINT	POTTS GPS	NORTHING	EASTING	POINT	POTTS
LATITUDE 35°32'10.01375"N	EASTING 1367175.740SFT	NORTHING 656819.201SFT	EASTING 1367175.732SFT	POINT POTTS	NORTHING 656819.227SFT
LONGITUDE 81°07'38.22807"W	ELEVATION 1028.366SFT	EASTING 1367175.732SFT	ELEVATION 1028.430SFT	EASTING 1367175.732SFT	ELEVATION 1028.430SFT
HEIGHT 924.709SFT	HORZ ERROR 0.027SFT	UTILIZED HORZ AND VERT	VERT ERROR 0.064SFT	UTILIZED HORZ AND VERT	UTILIZED HORZ AND VERT
	3D ERROR 0.069SFT	QUALITY CONTROL QUALITY	3D ERROR 0.069SFT	QUALITY CONTROL QUALITY	QUALITY CONTROL QUALITY
POINT M 002 GPS	NORTHING 642246.045SFT	POINT M 002	NORTHING 642246.030SFT	POINT M 002	NORTHING 642246.030SFT
LATITUDE 35°30'00.57380"N	EASTING 1440608.788SFT	EASTING 1440608.827SFT	ELEVATION 777.608SFT	EASTING 1440608.827SFT	ELEVATION 777.590SFT
LONGITUDE 80°52'46.56200"W	ELEVATION 777.608SFT	UTILIZED HORZ AND VERT	HORZ ERROR 0.042SFT	UTILIZED HORZ AND VERT	UTILIZED HORZ AND VERT
HEIGHT 675.459SFT	HORZ ERROR 0.018SFT	QUALITY CONTROL QUALITY	VERT ERROR 0.018SFT	QUALITY CONTROL QUALITY	QUALITY CONTROL QUALITY
	3D ERROR 0.045SFT		3D ERROR 0.045SFT		
POINT B2146-2 GPS	NORTHING 725410.571SFT	POINT B2146-2	NORTHING 725410.569SFT	POINT B2146-2	NORTHING 725410.569SFT
LATITUDE 35°43'24.91247"N	EASTING 1399664.539SFT	EASTING 1399664.529SFT	ELEVATION 805.655SFT	EASTING 1399664.529SFT	ELEVATION 805.497SFT
LONGITUDE 81°01'22.12872"W	ELEVATION 805.655SFT	UTILIZED HORZ AND VERT	HORZ ERROR 0.011SFT	UTILIZED HORZ AND VERT	UTILIZED HORZ AND VERT
HEIGHT 701.009SFT	HORZ ERROR 0.158SFT	QUALITY ADJUSTED QUALITY	VERT ERROR 0.158SFT	QUALITY ADJUSTED QUALITY	QUALITY ADJUSTED QUALITY
	3D ERROR 0.158SFT		3D ERROR 0.158SFT		
POINT B2146-1 GPS	NORTHING 725374.349SFT	POINT B2146-1	NORTHING 725374.345SFT	POINT B2146-1	NORTHING 725374.345SFT
LATITUDE 35°43'34.69532"N	EASTING 1400364.597SFT	EASTING 1400364.582SFT	ELEVATION 850.214SFT	EASTING 1400364.582SFT	ELEVATION 850.058SFT
LONGITUDE 81°01'13.63145"W	ELEVATION 850.214SFT	UTILIZED HORZ AND VERT	HORZ ERROR 0.015SFT	UTILIZED HORZ AND VERT	UTILIZED HORZ AND VERT
HEIGHT 745.577SFT	HORZ ERROR 0.156SFT	QUALITY ADJUSTED QUALITY	VERT ERROR 0.156SFT	QUALITY ADJUSTED QUALITY	QUALITY ADJUSTED QUALITY
	3D ERROR 0.157SFT		3D ERROR 0.157SFT		

NOTES:

1. THE SITE CALIBRATION SHOWN IS BASED UPON A NETWORK TIED TO THE HARN (HIGH ACCURACY REFERENCE NETWORK) NAD 8395 ADJUSTMENT. THIS CALIBRATION WILL ALLOW THE END USER TO WORK WITHIN THE SAME COORDINATE SYSTEM WHEN USING RTK (REAL TIME KINEMATIC) GPS AND A LOCAL BASE STATION. IF ANOTHER SYSTEM SUCH AS VRS (VIRTUAL REFERENCE STATION) IS USED, ADDITIONAL FIELD TIES MAY BE NEEDED TO REDUCE POSSIBLE ERRORS, OR BIASES.

2. THE CONTROL DATA FOR THIS PROJECT CAN BE FOUND ELECTRONICALLY BY SELECTING PROJECT CONTROL DATA AT:
[HTTP://WWW.NCDOT.ORG/PRECONSTRUCT/HIGHWAY/LOCATION/PROJECT/](http://www.ncdot.org/preconstruct/highway/location/project/)

THE FILES TO BE FOUND ARE AS FOLLOWS:

- B2146_LS_GPSCALIB_041221.HTML
- B2146_LS_WGS84_041221.TXT
- B2146_LS_LOCAL_041221.TXT
- B2146_LS_CONTROL_050819.TXT

THE WGS84 AND LOCAL FILES ARE COMMA DELIMITED AND CAN BE USED TO REPRODUCE THE SITE CALIBRATION FOR THE END USER'S GPS EQUIPMENT. IF FURTHER INFORMATION IS NEEDED, PLEASE CONTACT THE LOCATION AND SURVEYS UNIT.

- © INDICATES GEODETIC CONTROL MONUMENTS USED OR SET FOR HORIZONTAL PROJECT CONTROL BY THE NCDOT LOCATION AND SURVEYS UNIT.
 PROJECT CONTROL ESTABLISHED USING GLOBAL POSITIONING SYSTEM.
 NETWORK ESTABLISHED FROM EXISTING HARN MONUMENTATION

DATUM DESCRIPTION

THE LOCALIZED COORDINATE SYSTEM DEVELOPED FOR THIS PROJECT IS BASED ON THE STATE PLANE COORDINATES ESTABLISHED BY NCDOT FOR MONUMENT "B2146-1" WITH NAD 1983/2001 STATE PLANE GRID COORDINATES OF NORTHING: 725374.345(ft) EASTING: 1400364.582(ft) THE AVERAGE COMBINED GRID FACTOR USED ON THIS PROJECT (GROUND TO GRID) IS: 0.999872000 THE N.C. LAMBERT GRID BEARING AND LOCALIZED HORIZONTAL GROUND DISTANCE FROM "B2146-1" TO -L- PT STATION 13+54.00 IS S 66°27'17.5" W 1618.850' ALL LINEAR DIMENSIONS ARE LOCALIZED HORIZONTAL DISTANCES VERTICAL DATUM USED IS NAVD 88

1/06/06

PAVEMENT SCHEDULE	
C	PROP. APPROX. 1 1 / 4" ASPHALT CONCRETE SURFACE COURSE, TYPE SF9.5A, AT AN AVERAGE RATE OF 137.5 LBS. PER SQ. YD.
C1	PROP. APPROX. 2 1 / 2" ASPHALT CONCRETE SURFACE COURSE, TYPE SF9.5A, AT AN AVERAGE RATE OF 137.5 LBS. PER SQ. YD. IN EACH OF TWO LAYERS.
C2	PROP. VAR. DEPTH ASPHALT CONCRETE SURFACE COURSE, TYPE SF9.5A, AT AN AVERAGE RATE OF 110 LBS. PER SQ. YD. PER 1" DEPTH TO PLACED IN LAYERS NOT TO EXCEED 1 1 / 2" IN DEPTH.
E1	PROP. APPROX. 5" ASPHALT CONCRETE BASE COURSE, TYPE B25.0B, AT AN AVERAGE RATE OF 570 LBS. PER SQ. YD.
E2	PROP. VAR. DEPTH ASPHALT CONCRETE BASE COURSE, TYPE B25.0B, AT AN AVERAGE RATE OF 114 LBS. PER SQ. YD. PER 1" DEPTH TO PLACED IN LAYERS NOT LESS THAN 3" IN DEPTH OR GREATER THAN 5 1 / 2" IN DEPTH.
T	EARTH MATERIAL
U	EXISTING PAVEMENT
W	WEDGING (SEE WEDGING DETAIL)

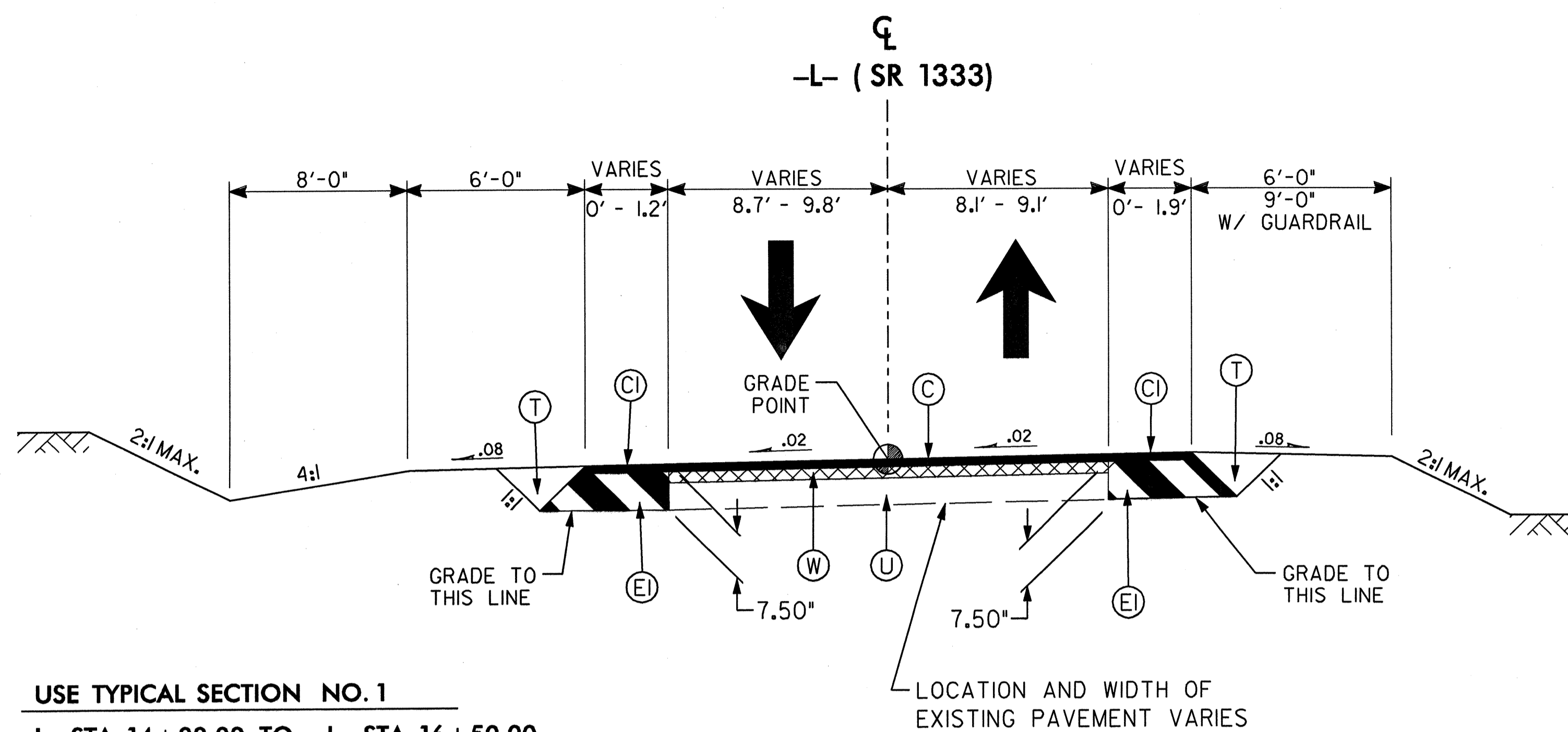

USE TYPICAL SECTION NO. 1
 -L- STA. 14+00.00 TO -L- STA. 16+50.00
 -L- STA. 21+25.00 TO -L- STA. 22+25.00

TYPICAL SECTION NO. 1

NOTE: PAVEMENT EDGE SLOPES ARE 1:1 UNLESS SHOWN OTHERWISE.

NOTE:
 FEATHER TO EXISTING PAVEMENT FROM
 -L- STA. 13+75.00 TO STA. 14+00.00 AND
 FROM -L- STA. 22+25.00 TO STA. 22+50.00

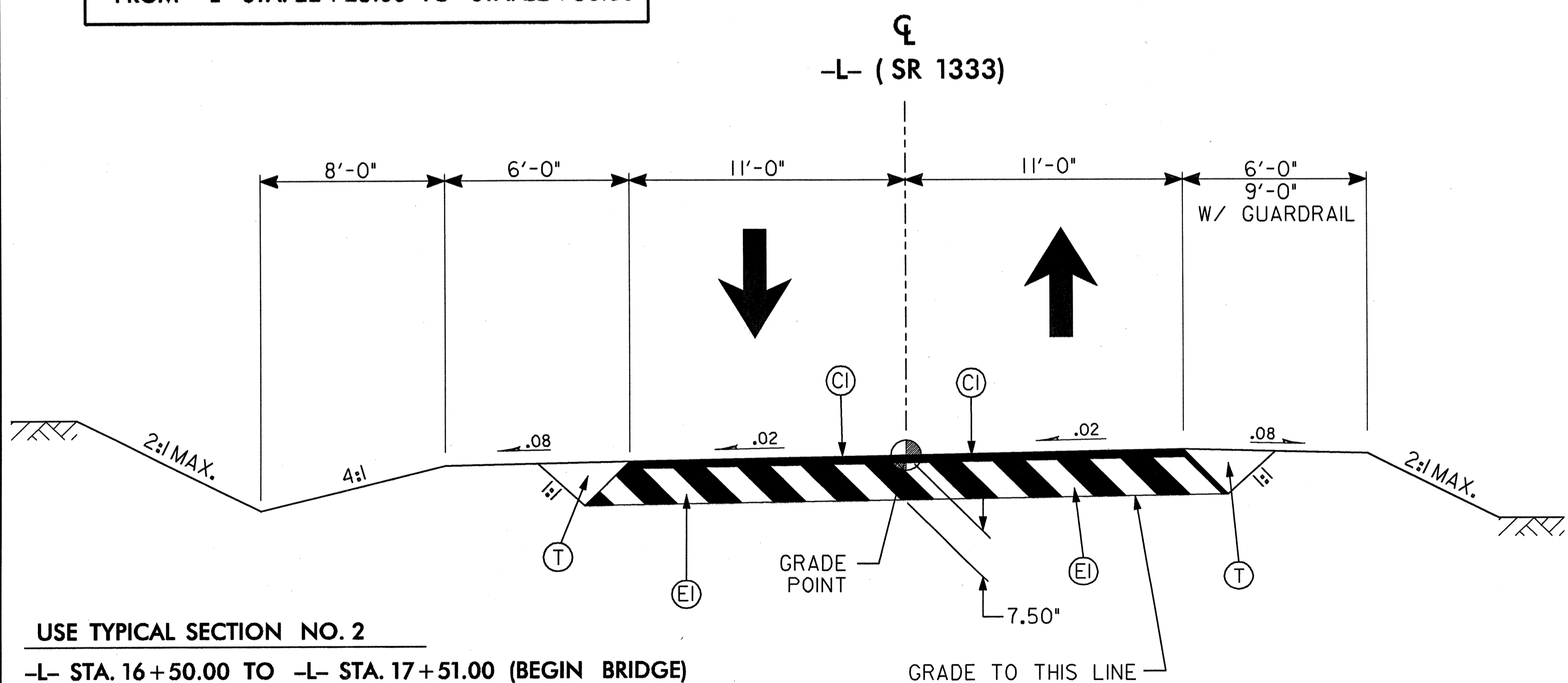

USE TYPICAL SECTION NO. 2
 -L- STA. 16+50.00 TO -L- STA. 17+51.00 (BEGIN BRIDGE)
 -L- STA. 18+76.00 (END BRIDGE) TO -L- STA. 21+25.00

TYPICAL SECTION NO. 2

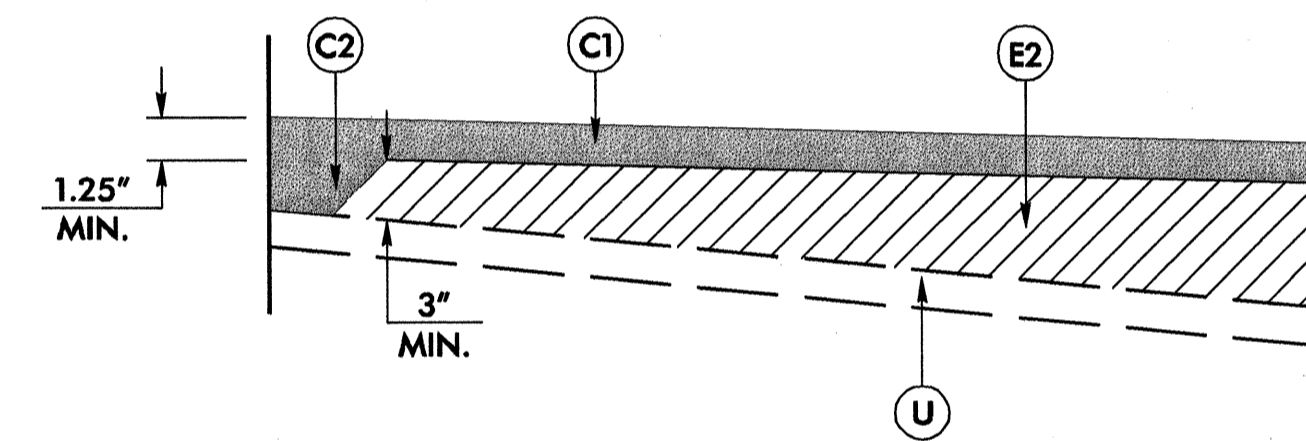

Detail Showing Method of Wedging

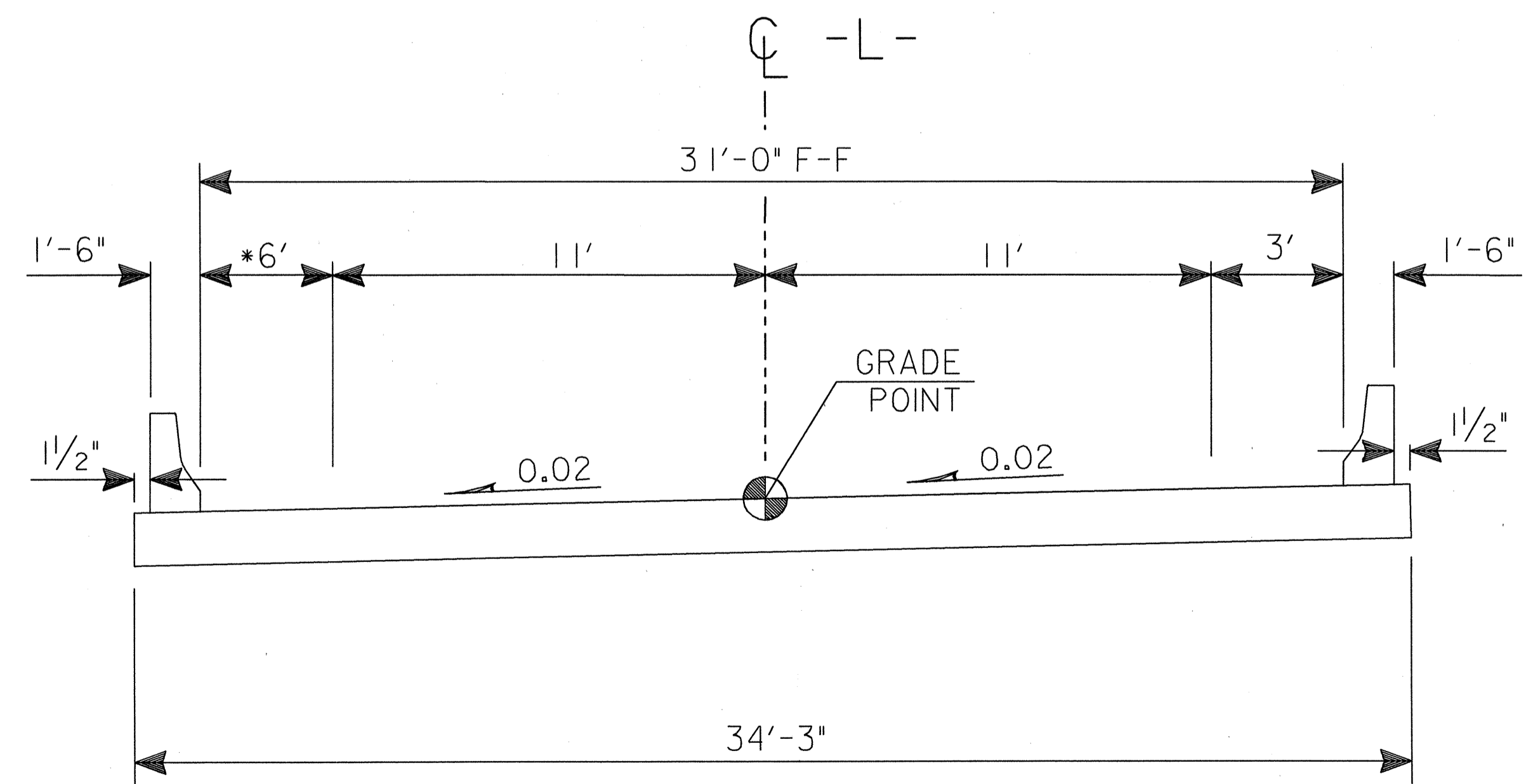

STEEL GIRDER DETAIL

* WIDENED FOR HYDRAULIC SPREAD ON STRUCTURE

STATE OF NORTH CAROLINA
DEPT. OF TRANSPORTATION
DIVISION OF HIGHWAYS
RALEIGH, N.C.

ENGLISH DETAIL DRAWING FOR
ANCHORAGE FOR FRAMES
BRICK/CONCRETE/PRECAST CONCRETE

SHEET 1 OF 1
840D25

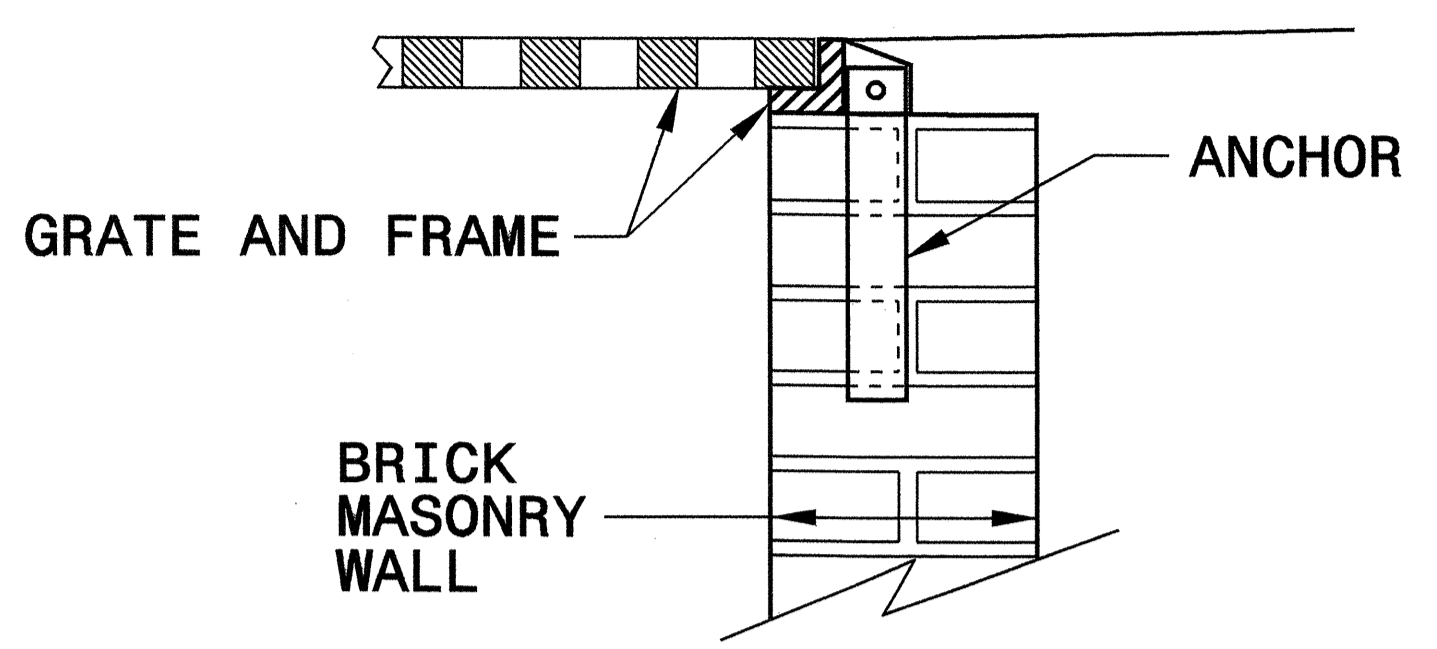

BRICK MASONRY CONSTRUCTION

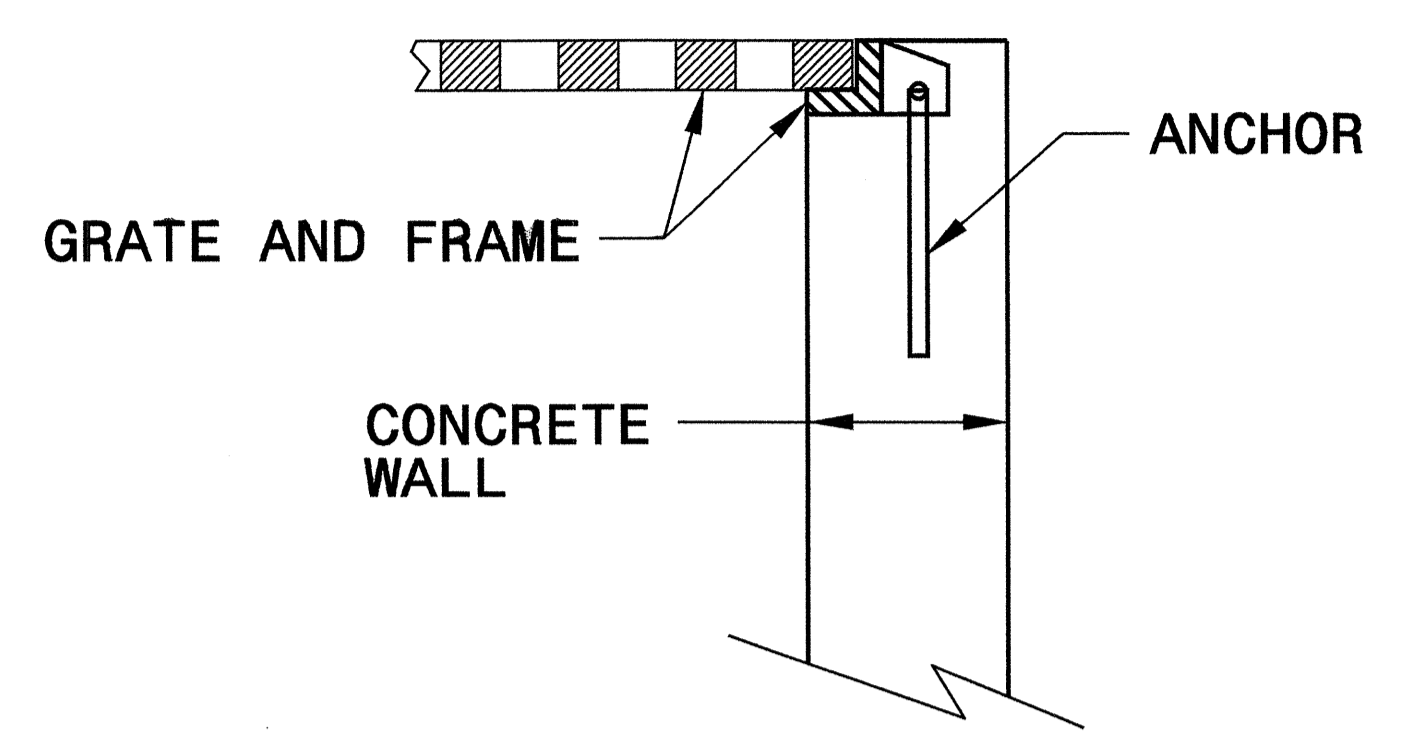

CONCRETE CONSTRUCTION

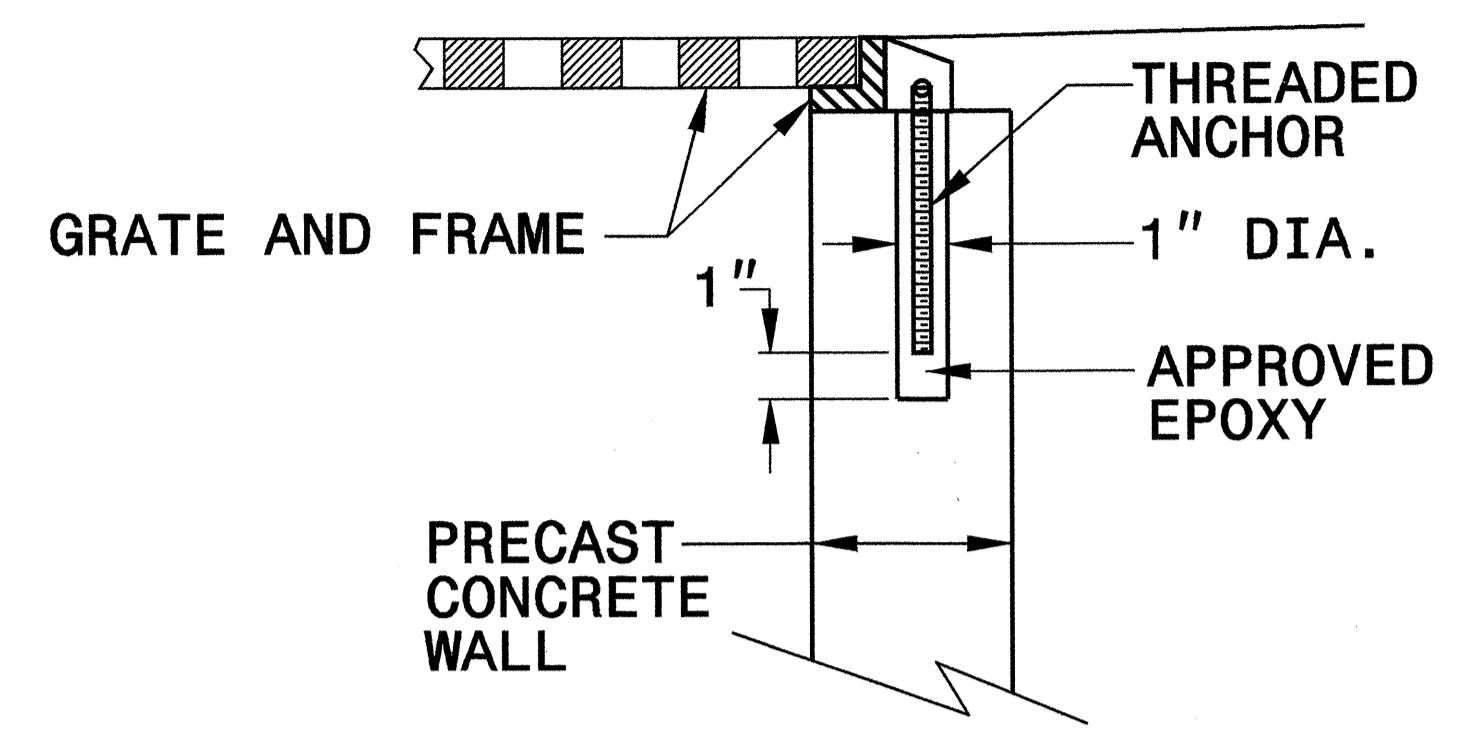

PRECAST CONCRETE CONSTRUCTION

DETAIL SHOWING ANCHORAGE OF FRAME FOR GRATED DROP INLET

NOTE:
CONSTRUCT GRATED DROP INLET TO COINCIDE WITH NORMAL OR SUPERELEVATED SHOULDER OR PAVEMENT SLOPE.

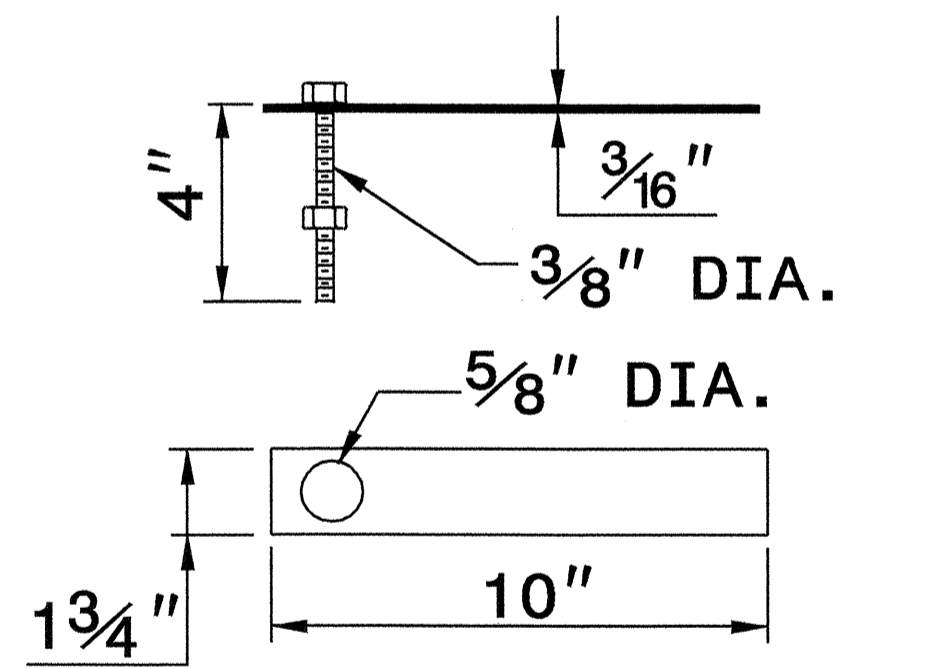

MASONRY ANCHOR
3/8" DIA. BOLT WITH PLATE

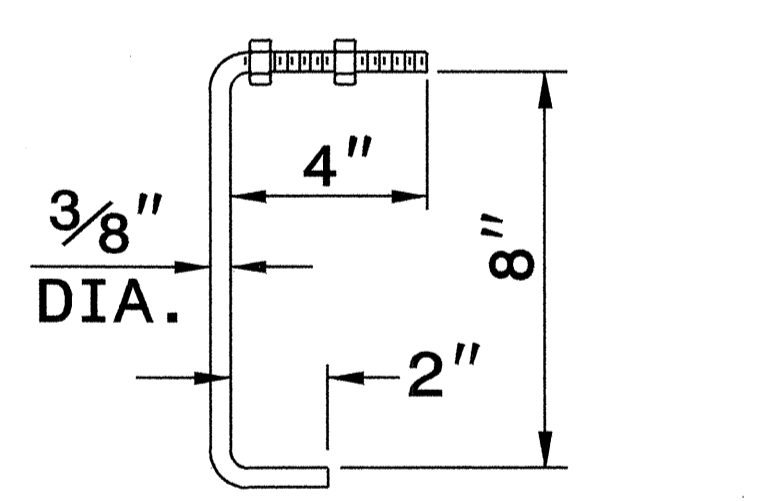

CONCRETE ANCHOR
3/8" DIA. BENT BAR

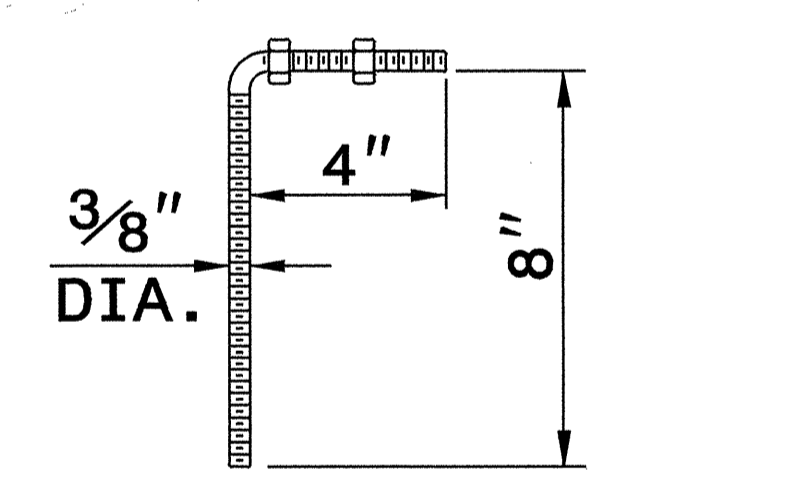

PRECAST CONCRETE ANCHOR
3/8" DIA. BENT BAR

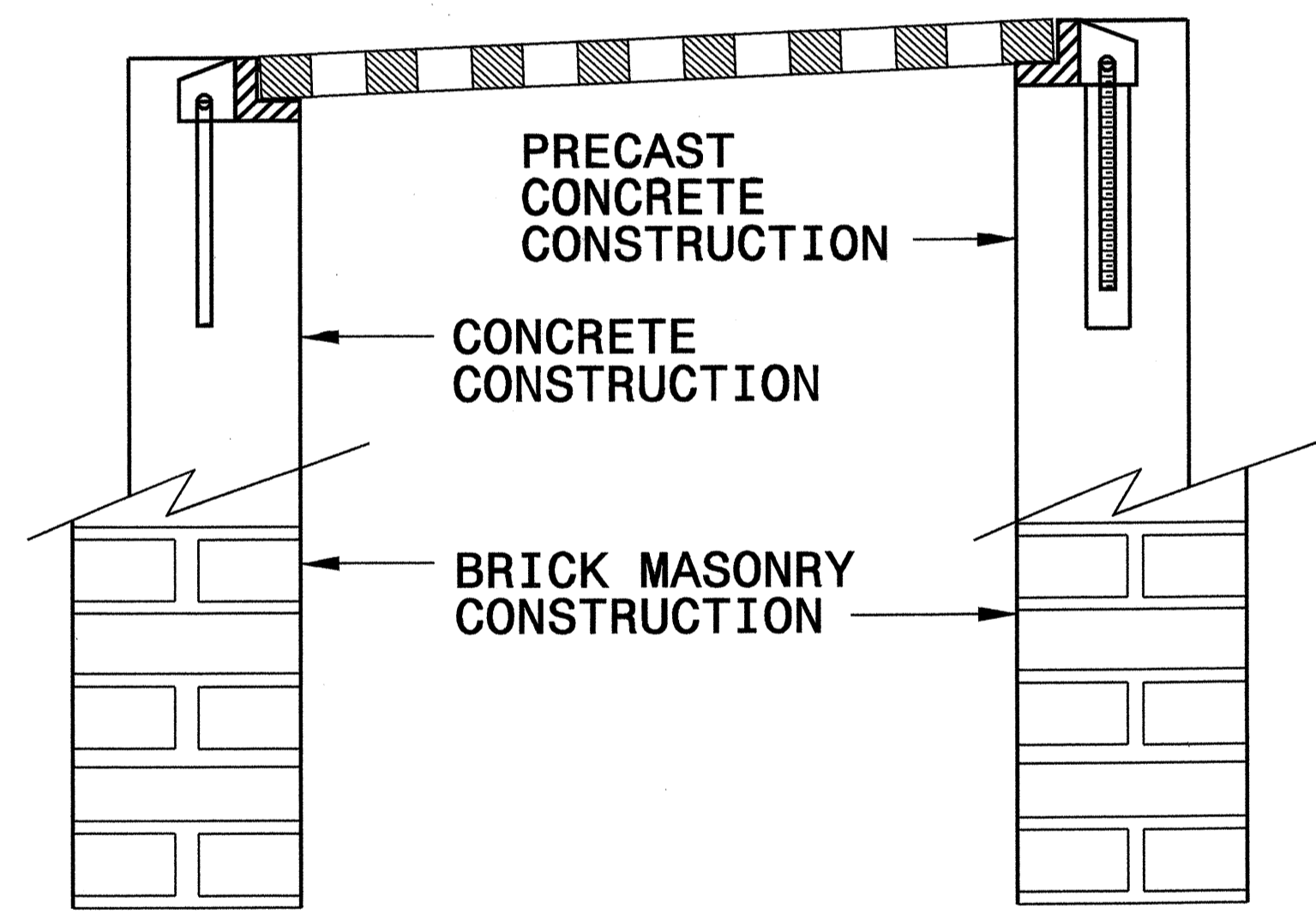

FRAME AND GRATE INSTALLATION FOR NORMAL CROWN AND SUPERELEVATED SECTIONS

STATE OF NORTH CAROLINA
DEPT. OF TRANSPORTATION
DIVISION OF HIGHWAYS
RALEIGH, N.C.

ENGLISH DETAIL DRAWING FOR
ANCHORAGE FOR FRAMES
BRICK/CONCRETE/PRECAST CONCRETE

SHEET 1 OF 1
840D25

01-MAR-2007 09:04 projects\special_details\ward\stds\06\stds to special_details\84025 anchorage for frames\0840d25.dgn



**PROJECT SERVICES UNIT
STANDARDS AND SPECIAL DESIGN**
Office 919-250-4128 FAX 919-250-4119

SEE PLATE FOR TITLE

ORIGINAL BY: 2006 STD 840.25 DATE: 07/18/06
MODIFIED BY: E.E. WARD DATE: 9/25/06
CHECKED BY: _____ DATE: _____
FILE SPEC.: _____

SUMMARY OF QUANTITIES

STATE OF NORTH CAROLINA
DIVISION OF HIGHWAYS
ROADWAY SUMMARY OF QUANTITIES FOR CONTRACT - C201785

ItemNumber	Sec #	Quantity	Unit	Description
000100000-N	800	Lump Sum		MOBILIZATION
002200000-E	225	2,040	CY	UNCLASSIFIED EXCAVATION
002900000-N	SP	Lump Sum		REINFORCED BRIDGE APPROACH FILL, STATION ***** (18+13.50)
005000000-E	226	1	ACR	SUPPLEMENTARY CLEARING & GRUBBING
005700000-E	226	200	CY	UNDERCUT EXCAVATION
006300000-N	SP	Lump Sum		GRADING
013400000-E	240	20	CY	DRAINAGE DITCH EXCAVATION
031800000-E	300	23	TON	FOUNDATION CONDITIONING MATERIAL, MINOR STRS
034200000-E	310	20	LF	*** SIDE DRAIN PIPE (30")
034500000-E	310	20	LF	24" SIDE DRAIN PIPE
036600000-E	310	28	LF	15" RC PIPE CULVERTS, CLASS III
037800000-E	310	60	LF	24" RC PIPE CULVERTS, CLASS III
070800000-E	310	80	LF	15" BIT COAT CS PIPE CULVERTS, TYPE B 0.064" THICK
080600000-E	310	4	EA	15" BIT COAT CS PIPE ELBOWS, TYPE B 0.064" THICK
122000000-E	545	100	TON	INCIDENTAL STONE BASE
148900000-E	610	330	TON	ASPHALT CONC BASE COURSE, TYPE B25.0B
152500000-E	610	215	TON	ASPHALT CONC SURFACE COURSE, TYPE SF9.5A
156000000-E	620	29	TON	ASPHALT BINDER FOR PLANT MIX, GRADE PG 64-22
169300000-E	654	50	TON	ASPHALT PLANT MIX, PAVEMENT REPAIR
228600000-N	840	3	EA	MASONRY DRAINAGE STRUCTURES
236700000-N	840	3	EA	FRAME WITH TWO GRATES, STD 840.29
255600000-E	846	190	LF	SHOULDER BERM GUTTER
303000000-E	862	362.5	LF	STEEL BM GUARDRAIL

ItemNumber	Sec #	Quantity	Unit	Description
315000000-N	862	5	EA	ADDITIONAL GUARDRAIL POSTS
327000000-N	SP	4	EA	GUARDRAIL ANCHOR UNITS, TYPE 350
331700000-N	862	4	EA	GUARDRAIL ANCHOR UNITS, TYPE B-77
362800000-E	876	50	TON	RIP RAP, CLASS I
364900000-E	876	12	TON	RIP RAP, CLASS B
365600000-E	876	375	SY	FILTER FABRIC FOR DRAINAGE
440000000-E	1110	395	SF	WORK ZONE SIGNS (STATIONARY)
441000000-E	1110	94	SF	WORK ZONE SIGNS (BARRICADE MOUNTED)
444500000-E	1145	48	LF	BARRICADES (TYPE III)
481000000-E	1205	7,000	LF	PAINT PAVEMENT MARKING LINES (4")
600000000-E	1605	600	LF	TEMPORARY SILT FENCE
600600000-E	1610	105	TON	STONE FOR EROSION CONTROL, CLASS A
600900000-E	1610	115	TON	STONE FOR EROSION CONTROL, CLASS B
601200000-E	1610	120	TON	SEDIMENT CONTROL STONE
601500000-E	1615	1	ACR	TEMPORARY MULCHING
601800000-E	1620	100	LB	SEED FOR TEMPORARY SEEDING
602100000-E	1620	2.25	TON	FERTILIZER FOR TEMPORARY SEEDING
602400000-E	1622	50	LF	TEMPORARY SLOPE DRAINS
602700000-N	1622	1	EA	INLET PROTECTION AT TEMPORARY SLOPE DRAINS
602900000-E	SP	455	LF	SAFETY FENCE
603000000-E	1630	310	CY	SILT EXCAVATION
603600000-E	1631	815	SY	MATTING FOR EROSION CONTROL
603700000-E	SP	25	SY	COIR FIBER MAT
604200000-E	1632	265	LF	1/4" HARDWARE CLOTH
6071030000-E	SP	90	LF	COIR FIBER BAFFLES

ItemNumber	Sec #	Quantity	Unit	Description
607105000-E	SP	4	EA	*** SKIMMER (1-1/2")
608400000-E	1660	2	ACR	SEEDING & MULCHING
608700000-E	1660	1	ACR	MOWING
609000000-E	1661	50	LB	SEED FOR REPAIR SEEDING
609300000-E	1661	0.25	TON	FERTILIZER FOR REPAIR SEEDING
609600000-E	1662	50	LB	SEED FOR SUPPLEMENTAL SEEDING
610800000-E	1665	1	TON	FERTILIZER TOPDRESSING
611400000-N	SP	2	HR	SPECIALIZED HAND MOWING
611700000-N	SP	12	EA	RESPONSE FOR EROSION CONTROL

** DESIGN EXCEPTION FOR HORIZONTAL ALIGNMENT AND SAG VERTICAL CURVE REQUIRED

ROADWAY DESIGN ENGINEER
NORTH CAROLINA PROFESSIONAL SEAL 24416
SCOTT CLARK

HYDRAULICS ENGINEER
NORTH CAROLINA PROFESSIONAL SEAL 9334
HENRY WELLS, JR.

3-14-03

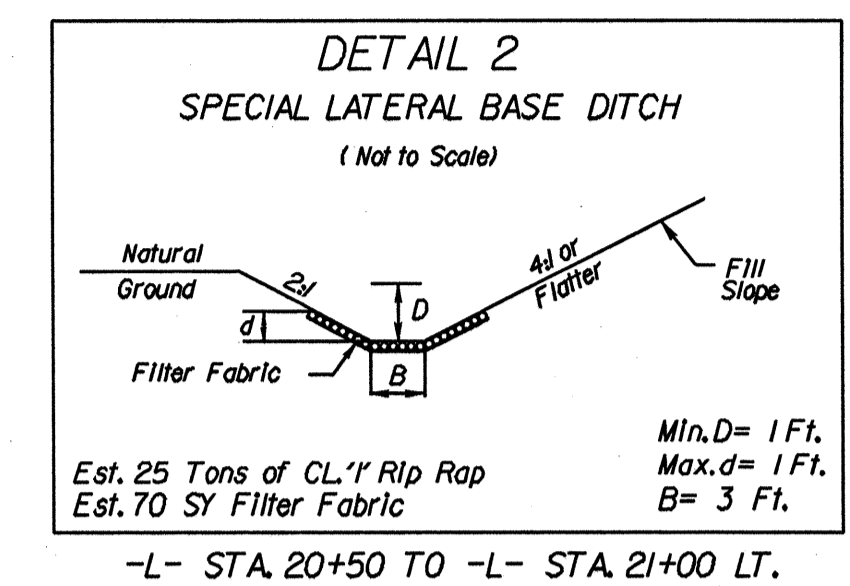
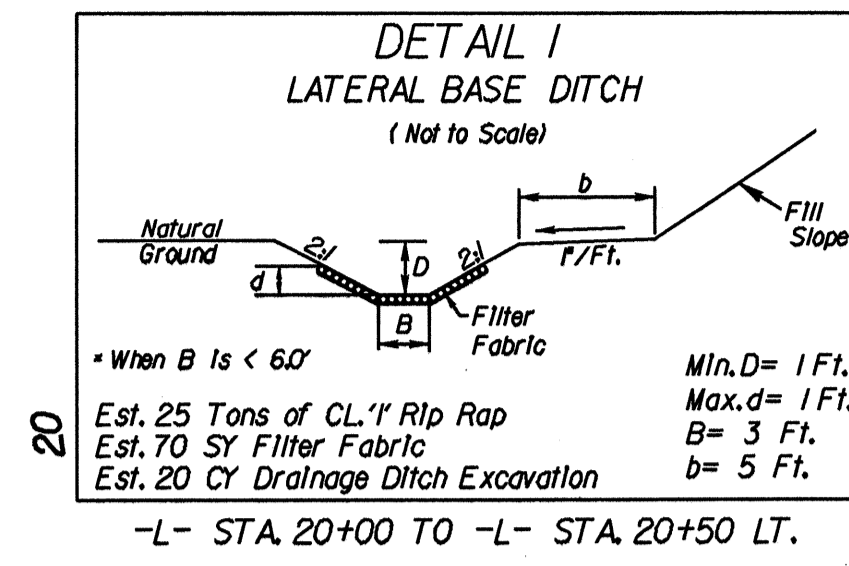
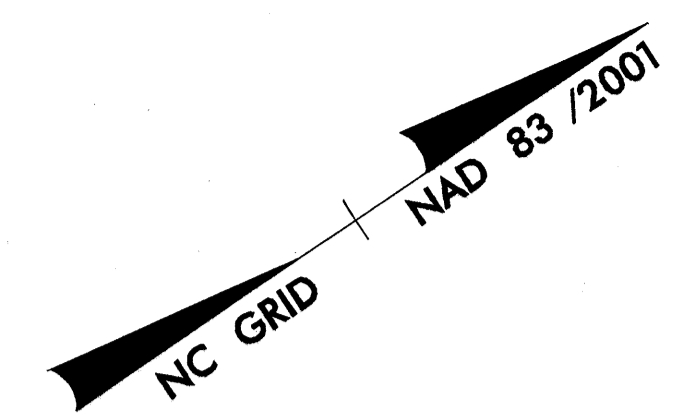

DO NOT IMPACT ENDANGERED PLANT

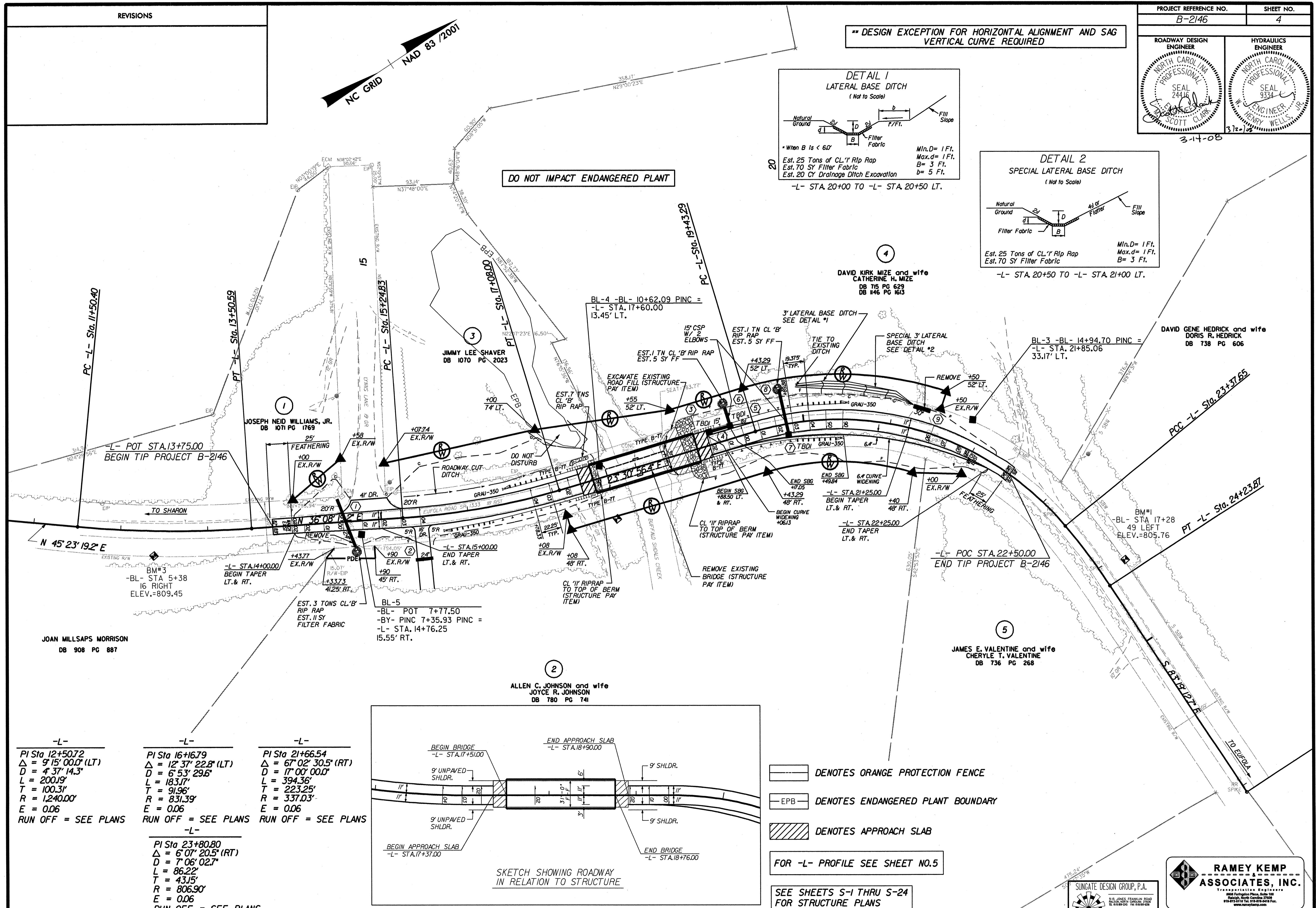

-L-	-L-	-L-
PI Sta 12+50.72	PI Sta 16+16.79	PI Sta 21+66.54
$\Delta = 9' 15'' 00.0''$ (LT)	$\Delta = 12' 37'' 22.8''$ (LT)	$\Delta = 67' 02'' 30.5''$ (RT)
$D = 4' 37'' 14.3''$	$D = 6' 53'' 29.6''$	$D = 17' 00'' 00.0''$
$L = 200.19'$	$L = 183.17'$	$L = 394.36'$
$T = 100.31'$	$T = 91.96'$	$T = 223.25'$
$R = 1,240.00'$	$R = 831.39'$	$R = 337.03'$
$E = 0.06$	$E = 0.06$	$E = 0.06$
RUN OFF = SEE PLANS	RUN OFF = SEE PLANS	RUN OFF = SEE PLANS
	-L-	
	PI Sta 23+80.80	
	$\Delta = 6' 07'' 20.5''$ (RT)	
	$D = 7' 06'' 02.7''$	
	$L = 86.22'$	
	$T = 43.15'$	
	$R = 806.90'$	
	$E = 0.06$	
	RUN OFF = SEE PLANS	

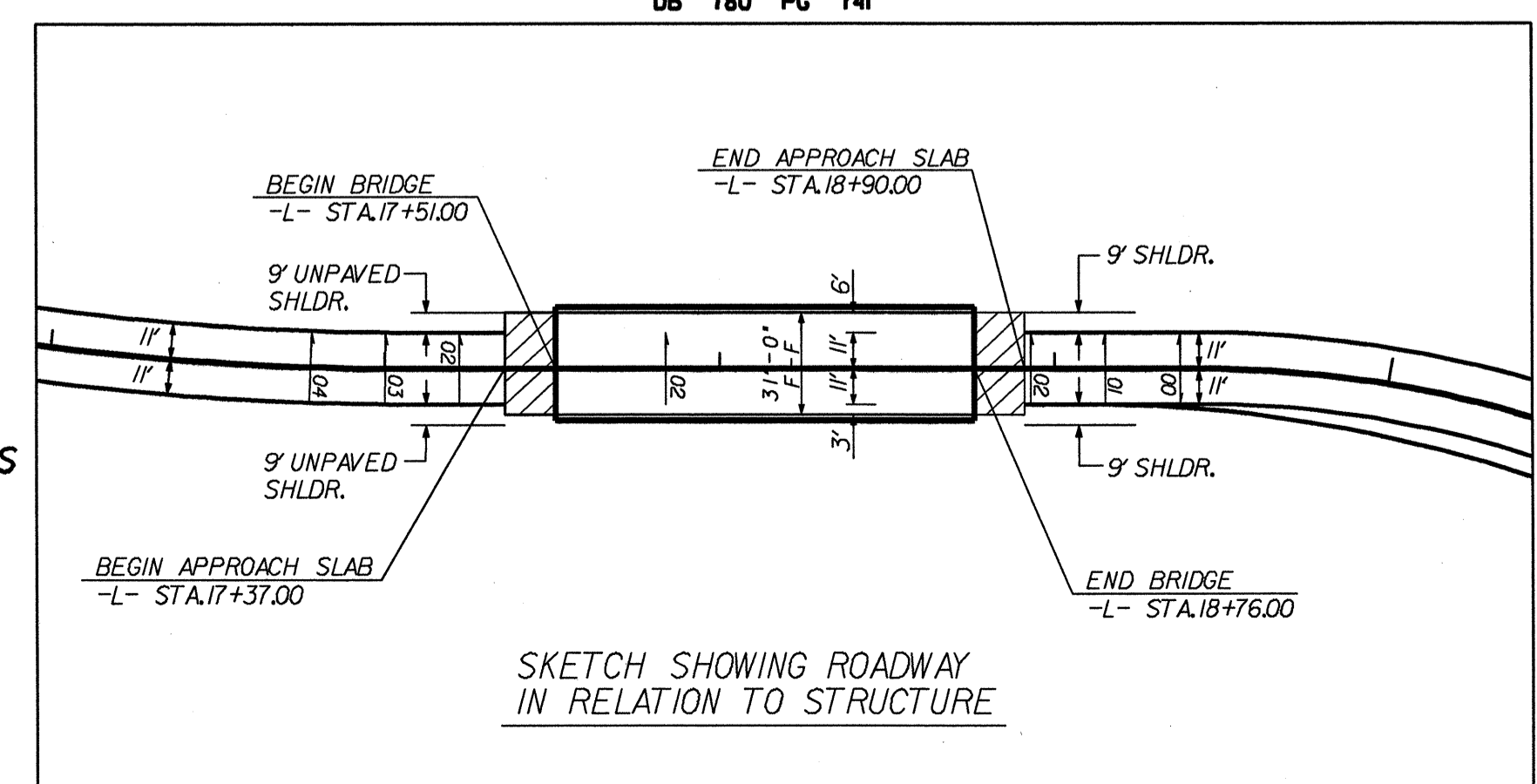

- DENOTES ORANGE PROTECTION FENCE
- DENOTES ENDANGERED PLANT BOUNDARY
- DENOTES APPROACH SLAB
- FOR -L- PROFILE SEE SHEET NO.5
- SEE SHEETS S-1 THRU S-24 FOR STRUCTURE PLANS

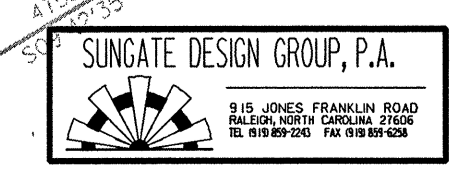

B.M.*2 ELEV.= 783.82
R.R SPIKE IN 2" PINE
63' RT.OF -BL- STA.10+75
53J4' RT.OF -L- STA.17+62.30

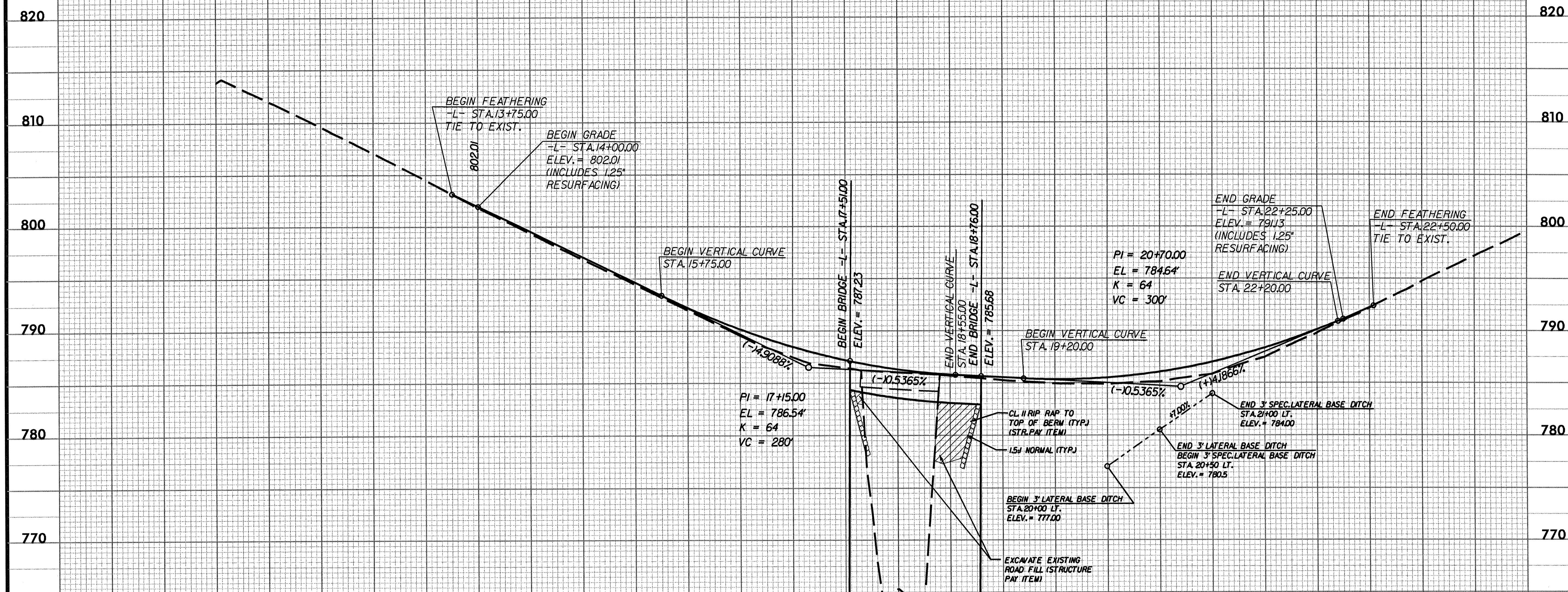

STRUCTURE HYDRAULIC DATA	
DESIGN DISCHARGE	= 3,400 CFS
DESIGN FREQUENCY	= 25 YRS
DESIGN HW ELEVATION	= 774.9 FT.
BASE DISCHARGE	= 5,010 CFS
BASE FREQUENCY	= 100 YRS
BASE HW ELEVATION	= 777.00 FT
OVERTOPPING DISCHARGE	= 7,340+ CFS
OVERTOPPING FREQUENCY	= 500+ YR.
OVERTOPPING ELEVATION	= 785.35 FT

-L-
(FOR PLAN, SEE SHEET NO.4)

** DESIGN EXCEPTION FOR HORIZONTAL ALIGNMENT AND SAG VERTICAL CURVE REQUIRED

FOR STRUCTURE PLANS, SEE SHEETS S-1 THRU S-24

 SUNGATE DESIGN GROUP, P.A. <small>215 JONES FRANKLIN ROAD RALEIGH, NORTH CAROLINA 27602 TEL: 919-872-6110 FAX: 919-872-6158</small>	 RAMEY KEMP ASSOCIATES, INC. <small>TRANSPORTATION ENGINEERS 8008 Farrington Place, Suite 100 Raleigh, North Carolina 27609 919-872-6110 Tel. 919-872-6416 Fax. www.rameykemp.com</small>
--	--