

STATE OF NORTH CAROLINA
DIVISION OF HIGHWAYS

BUNCOMBE COUNTY

LOCATION: NC 112 (SAND HILL ROAD) FROM SR 3446 (ENKA LAKE ROAD) TO SR 3412 (SAND HILL ROAD/SARDIS ROAD)

TYPE OF WORK: TRAFFIC SIGNALS

WBS: 37831

PROJECT: MA13028R

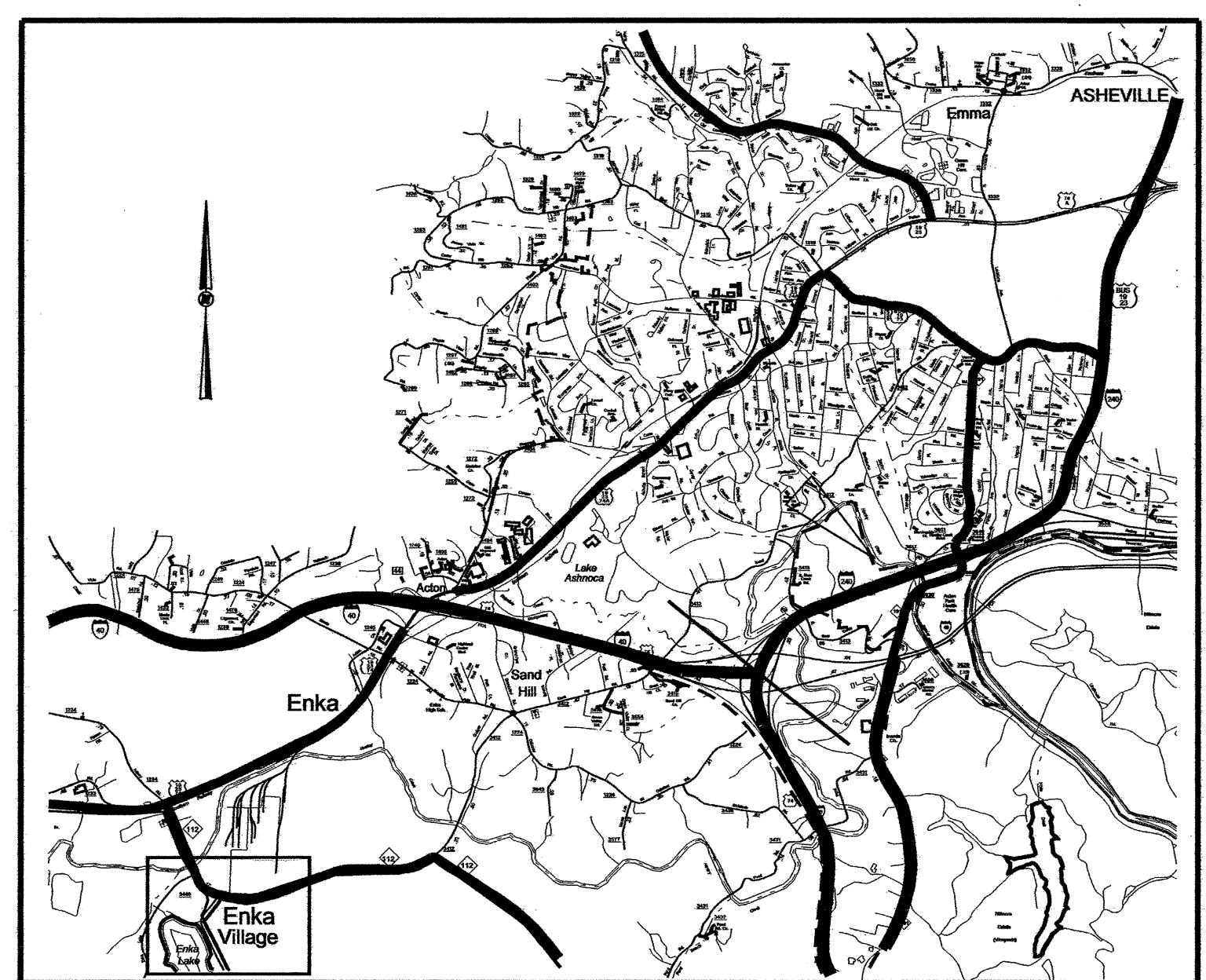

Vicinity Map

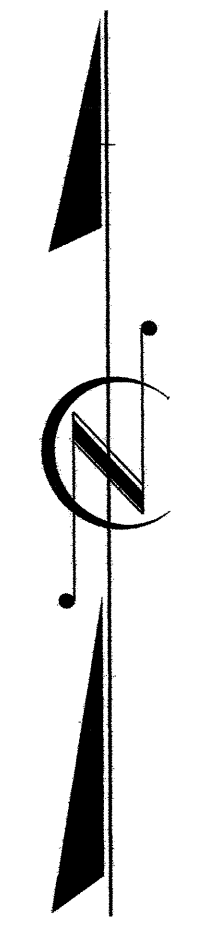
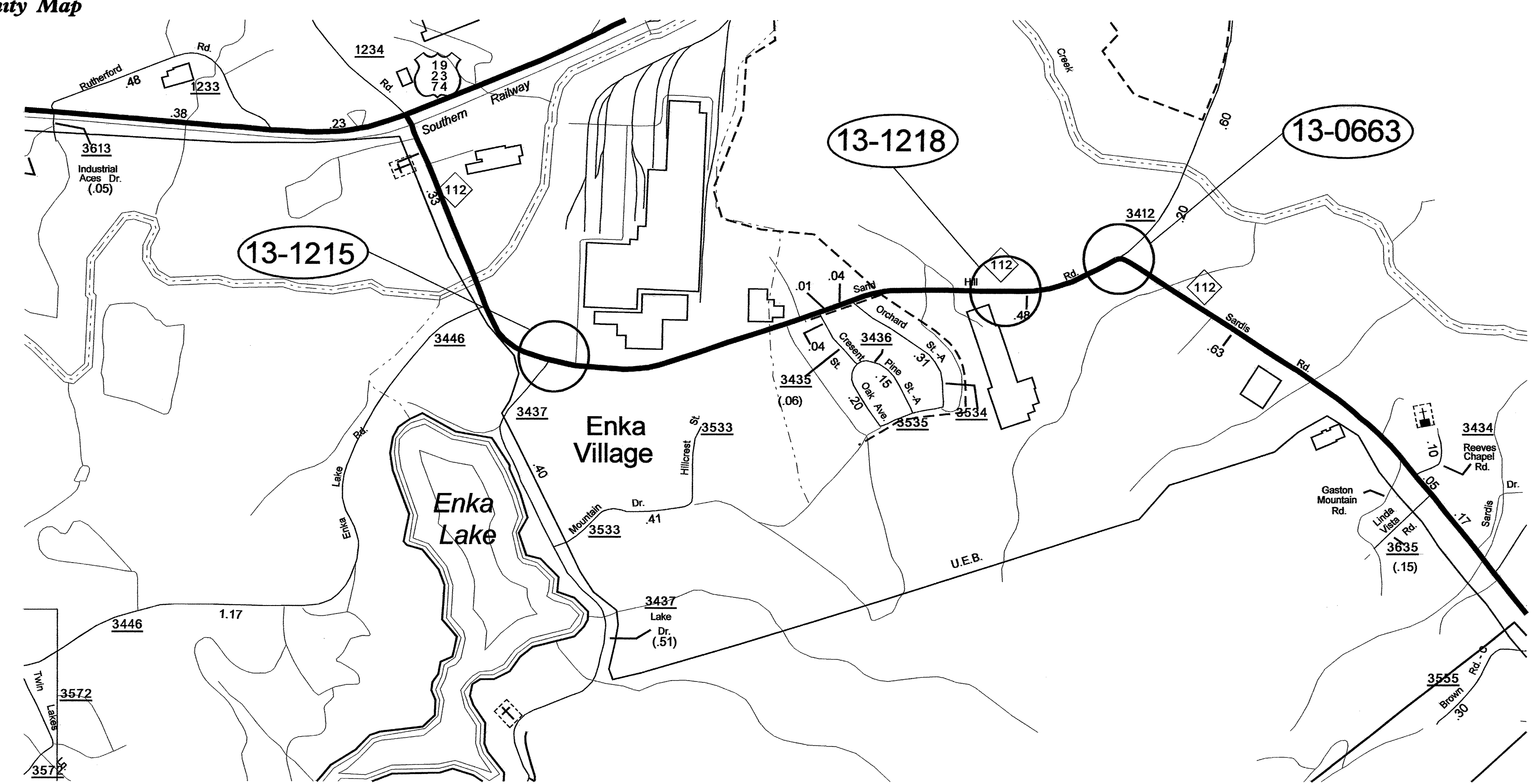

Index of Plans

Sheet #	Signal Inventory Number	Location/Description
Sig. 1		Title Sheet
Sig. 2-3	13-1215	NC 112 (Sand Hill Road) @ SR 3437 (Lake Drive)/Colbond Driveway
Sig. 4-6	13-1218	NC 112 (Sand Hill Road) @ Jacob Holm Drive/Southeastern Container
Sig. 7-13	13-0663	NC 112 (Sand Hill Road/Sardis Road) @ SR 3412 (Sand Hill Road)

INTELLIGENT TRANSPORTATION SYSTEMS AND SIGNALS UNIT

Contacts:
R.J. ZIEMBA, PE - S & G RAILROAD AND SPECIAL PROJECTS ENGINEER
G. C. BROWN, PE - SIGNAL EQUIPMENT DESIGN ENGINEER

Prepared in the Offices of:

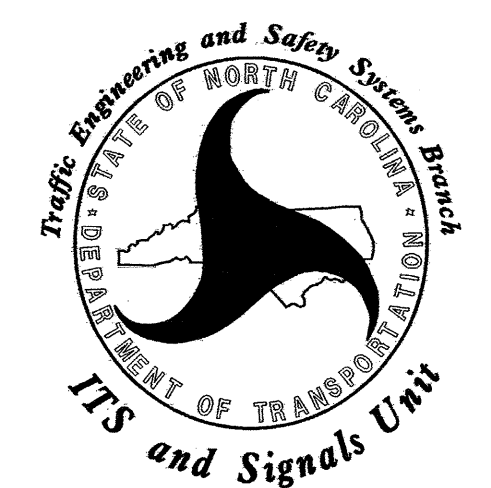

17-JAN-2008 14:05 I:\signals\workgroups\alexander\nc moving ahead\buncombe_co\buncombe_nema_37831_sig_1.tsh.dgn

EDI MODEL 2010ECL CONFLICT MONITOR

PROGRAMMING DETAIL

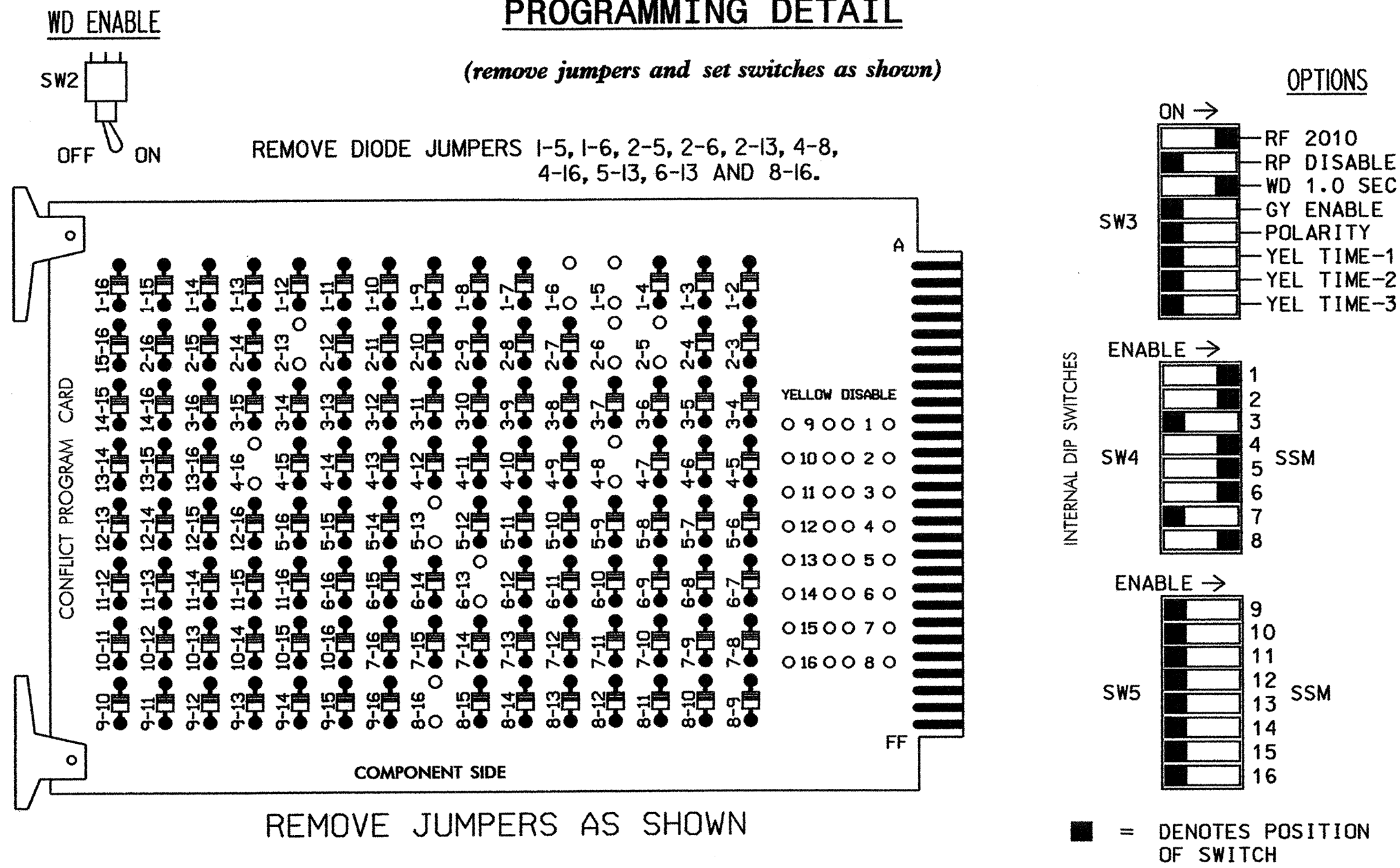

- NOTES:
- Card is provided with all diode jumpers in place. Removal of any jumper allows its channels to run concurrently.
 - Make sure jumpers SEL1-SEL5 are present on the monitor board.

INPUT FILE POSITION LAYOUT

(front view)

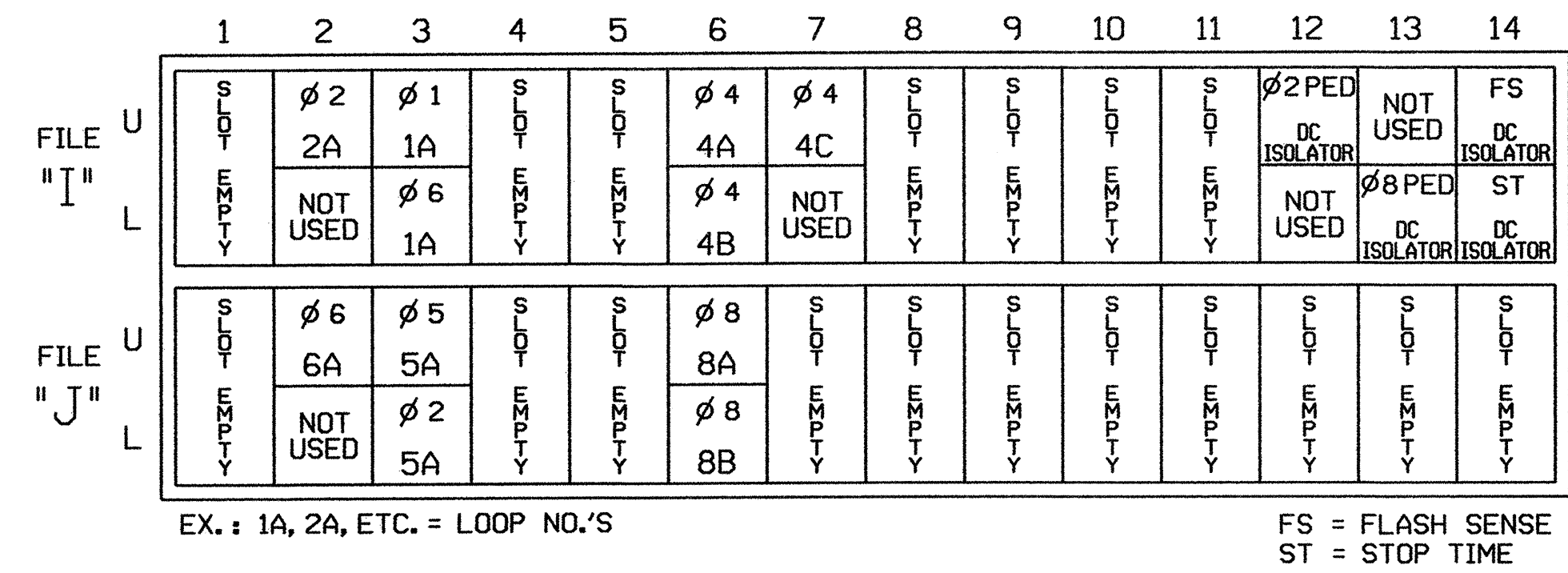

RED MONITOR BOARD PROGRAMMING

(position jumpers as shown below)

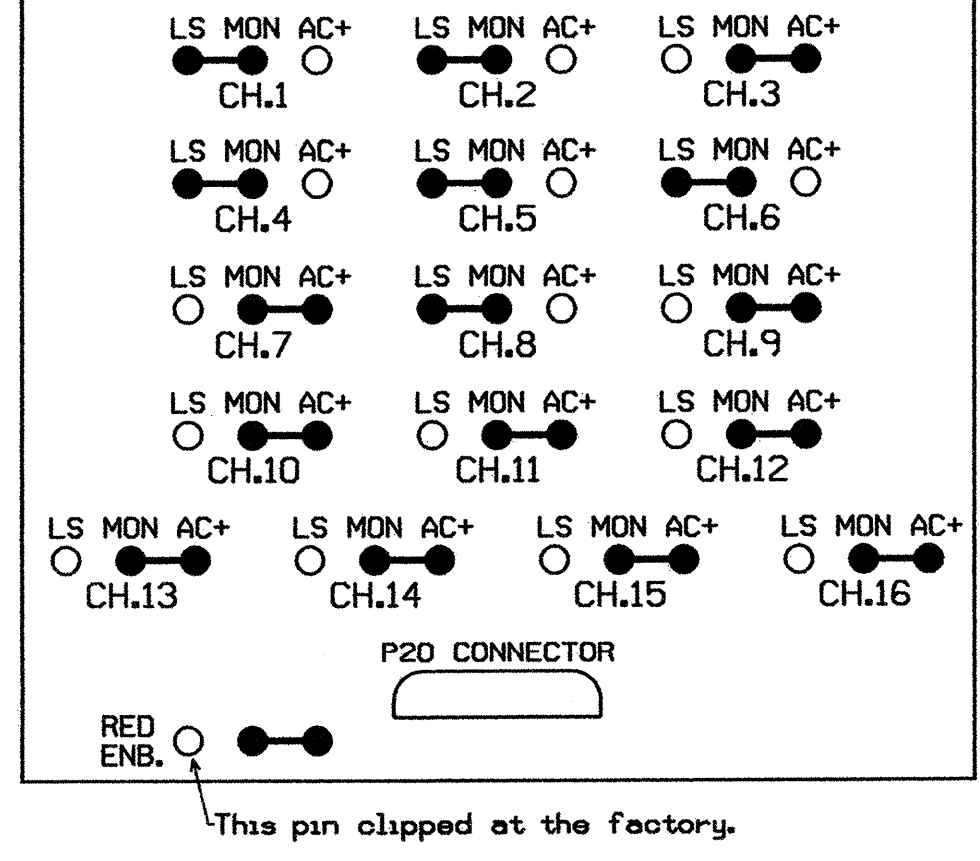

LOAD RESISTOR INSTALLATION DETAIL

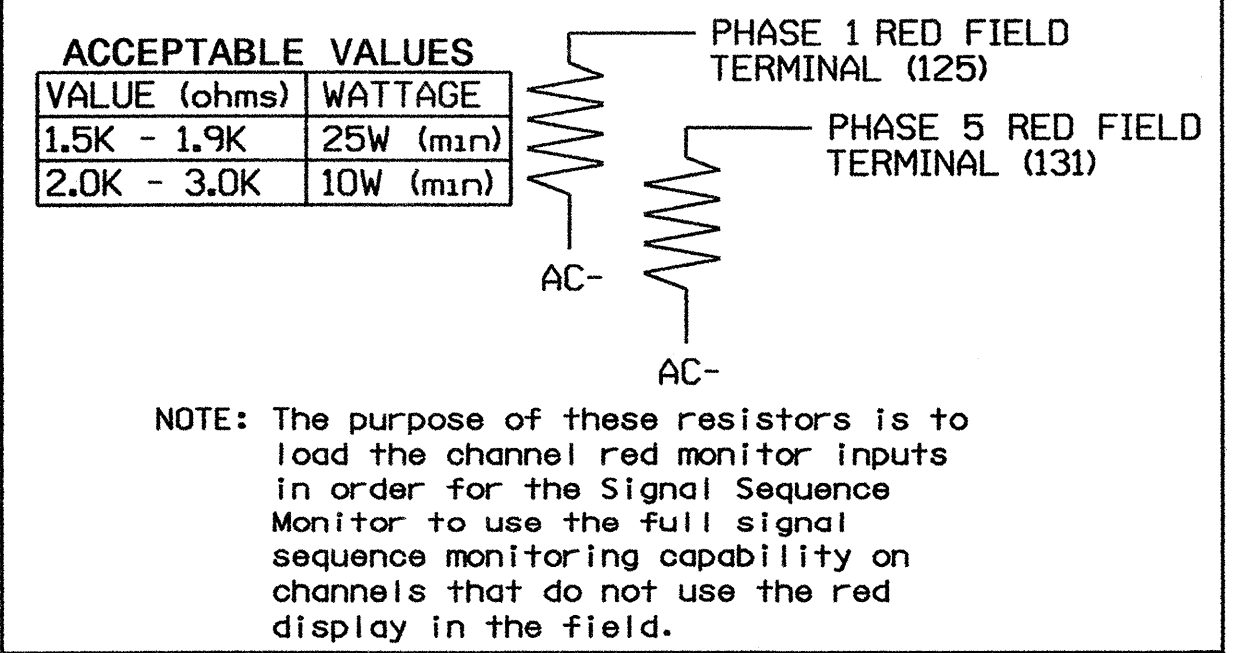

NOTES

- To prevent "flash-conflict" problems, insert red flash program blocks for all unused vehicle load switches in the output file. Verify that signal heads flash in accordance with the Signal Plans.
- To prevent red failures on unused monitor channels, see Red Monitor Board Programming Detail this sheet.
- Program phases 2 and 6, on the controller unit, for Start-Up in Green.
- Enable Simultaneous Gap-Out, on the controller unit, for all phases.
- Program phases 4 and 8, on the controller unit, for Dual Entry.
- Set all detector card channels to 'Presence' mode.
- Program phases 2 and 8 for 'STARTUP PED CALL'.

EQUIPMENT INFORMATION

*CONTROLLER.....EAGLE TYPE 2070L
*CABINET.....McCAIN/CONTROL TECHNOLOGIES (DWG.NO. 9500-332-NCDOT)
SOFTWARE.....ECONOLITE OASIS
CABINET MOUNT.....BASE
OUTPUT FILE POSITIONS...12
LOAD SWITCHES USED.....S1,S2,S2P,S4,S5,S6,S8,S8P
PHASES USED.....1,2,2PED,4,5,6,8,8PED
OVERLAPS.....NONE

EXISTING TO REMAIN IN USE*

INPUT FILE CONNECTION & PROGRAMMING CHART

LOOP NO.	LOOP TERMINAL	INPUT FILE POS.	PIN NO.	INPUT ASSIGNMENT NO.	DETECTOR NO.	NEMA PHASE	CALL	EXTEND	FULL TIME DELAY	STRETCH TIME	DELAY TIME
1A ¹	TB2-9,10	I3U	63	25	32	1	Y	Y			15
	TB2-11,12	I3L	76	38	42	6	Y	Y			
2A	TB2-5,6	I2U	39	1	2	2	Y	Y			
4A	TB4-9,10	I6U	41	3	4	4	Y	Y			3
4B	TB4-11,12	I6L	45	7	14	4	Y	Y			5
4C	TB6-1,2	I7U	65	27	34	4	Y	Y			15
5A ²	TB3-9,10	J3U	64	26	36	5	Y	Y			15
	TB3-11,12	J3L	77	39	46	2	Y	Y			
6A	TB3-5,6	J2U	40	2	6	6	Y	Y			
8A	TB5-9,10	J6U	42	4	8	8	Y	Y			3
8B	TB5-11,12	J6L	46	8	18	8	Y	Y			10
PED PUSH BUTTONS											
P21,P22	TB8-4,6	I12U	67	29	PED 2	2PED					
P81,P82	TB8-8,9	I13L	70	32	PED 8	8PED					

NOTE:
INSTALL DC ISOLATORS IN INPUT FILE SLOTS I12 AND I13.

- Add jumpers from TB2-9 to TB2-11, and from TB2-10 to TB2-12.
- Add jumpers from TB3-9 to TB3-11, and from TB3-10 to TB3-12.

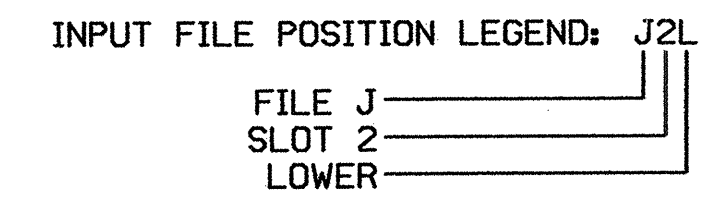

SIGNAL HEAD HOOK-UP CHART

LOAD SWITCH NO.	S1	S2	S2P	S3	S4	S4P	S5	S6	S6P	S7	S8	S8P
PHASE	1	2	2 PED	3	4	4 PED	5	6	6 PED	7	8	8 PED
SIGNAL HEAD NO.	61	21,22	P21, P22	NU	41,42	NU	21	61,62	NU	NU	81,82	P81, P82
RED	*	128			101		*	134			107	
YELLOW		129			102			135			108	
GREEN		130			103			136			109	
RED ARROW												
YELLOW ARROW	126						132					
GREEN ARROW	127						133					
Hand			113									110
Person			115									112

NU = Not Used **

- * Denotes install load resistor. See Load Resistor Installation Detail this sheet.
- ** See 'Countdown Pedestrian Signal Operation' note below.

COUNTDOWN PEDESTRIAN SIGNAL OPERATION

Countdown Ped Signals are required to display timing only during ped clearance interval. Consult Ped Signal Module user's manual for instructions on selecting this feature.

BACKUP PROTECTION NOTE

From Main Menu press '2' (Phase Control), then '1' (Phase Control Functions). Program phases 2 and 6 for 'Backup Protect'. Make sure the Red Revert times shown on the Signal Design Plans are programmed in the 'Phase Timing' menu.

THIS ELECTRICAL DETAIL IS FOR THE SIGNAL DESIGN: 13-1215
DESIGNED: JUNE 2007
SEALED: 6/18/07
REVISED: N/A

THIS DETAIL SUPERSEDES DETAIL DATED SEPTEMBER 2006 AND SEALED 9-14-06

ELECTRICAL AND PROGRAMMING DETAILS FOR:

Prepared in the Offices of:
John T. Rowe, Inc.
122 N. McDowell St., Raleigh, NC 27603

NC 112 (Sand Hill Road) at SR 3437 (Lake Drive)/Colbond Driveway

Division 13 Buncombe County Enka
PLAN DATE: JUNE 2007 REVIEWED BY: JTR
PREPARED BY: F.E. RUSS REVIEWED BY:
REVISIONS INIT. DATE

SEAL
JOHN T. ROWE, INC.
ENGINEER
008453
DATE: 6-22-07
SIG. INVENTORY NO. 13-1215

PHASING DIAGRAM

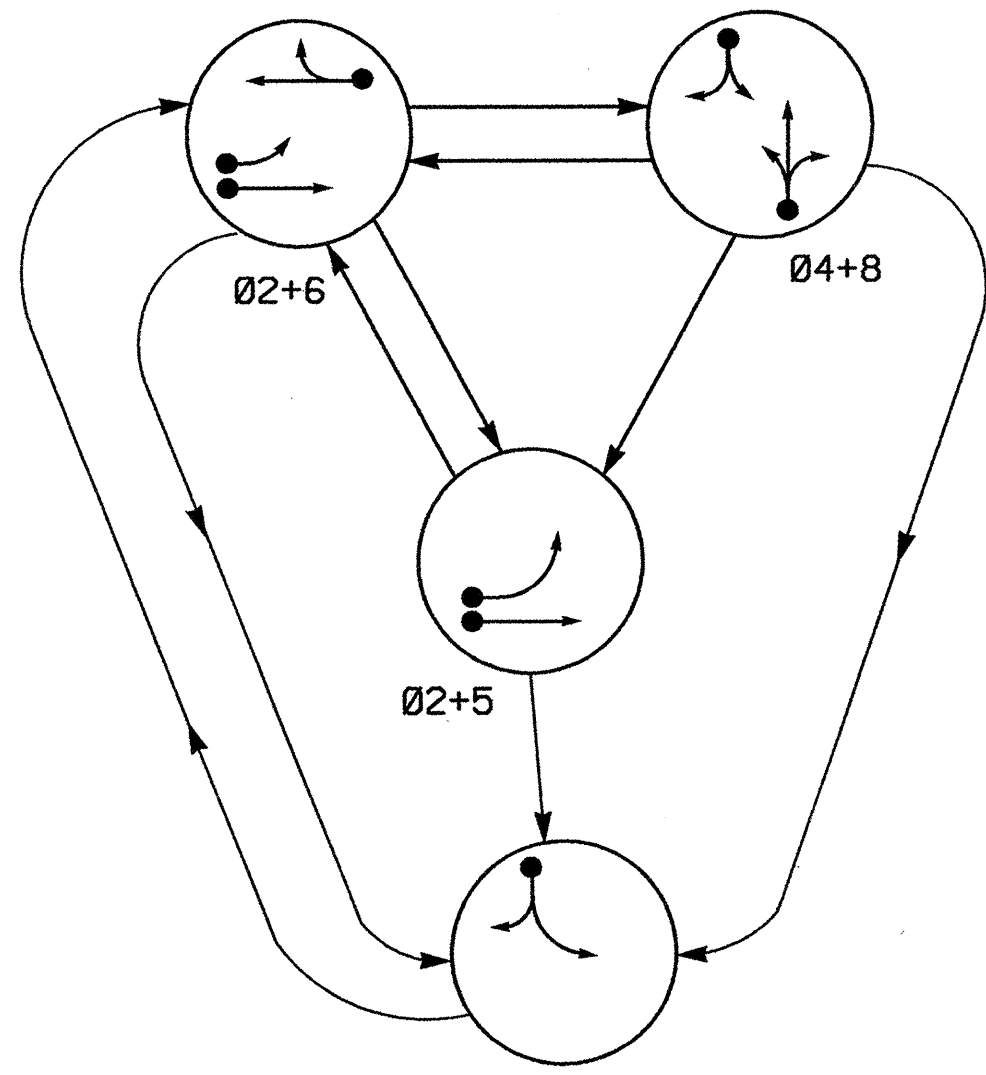

PHASING DIAGRAM DETECTION LEGEND

- DETECTED MOVEMENT
- UNDETECTED MOVEMENT (OVERLAP)
- UNSIGNALIZED MOVEMENT
- PEDESTRIAN MOVEMENT

TABLE OF OPERATION

SIGNAL FACE	PHASE				
	Ø2+5	Ø2+6	Ø4+8	EV P	EV T
21	G	G	R	R	Y
22	G	G	R	R	Y
41	R	R	G	G	R
42	R	R	G	G	R
61, 62	R	G	R	R	Y
81, 82	R	R	G	R	R

SIGNAL FACE I.D.

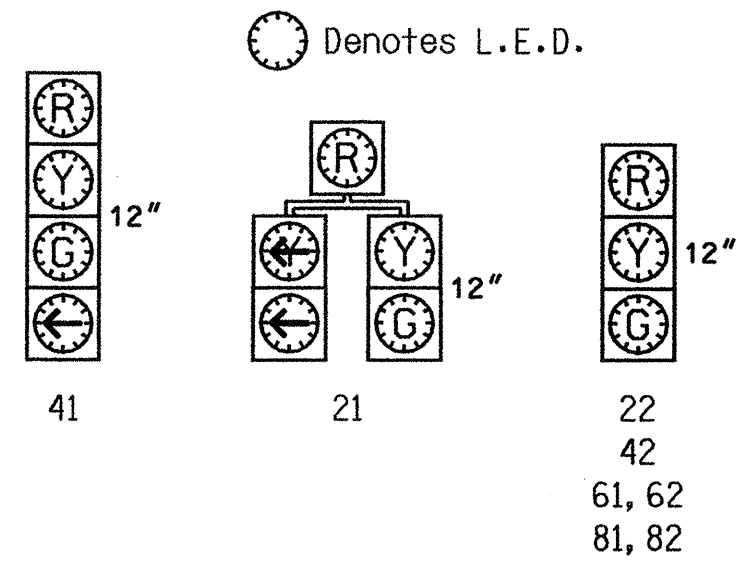

2070L LOOP & DETECTOR INSTALLATION

LOOP	SIZE (FT)	DISTANCE FROM STOPBAR (FT)	TURNS	NEW LOOP	DETECTOR PROGRAMMING					SYSTEM LOOP	NEW CARD
					PHASE	CALLING	EXTENSION	FULL TIME DELAY	STRETCH TIME		
2A	6X6	70	3	Y	2	Y	Y	-	-	-	Y
4A	6X40	0	2-4-2	Y	4	Y	Y	-	-	10	Y
5A	6X40	0	2-4-2	Y	2	Y	Y	-	-	15	Y
6A	6X6	70	3	Y	6	Y	Y	-	-	-	Y
8A	6X40	0	2-4-2	Y	8	Y	Y	-	-	10	Y
8B	6X20	0	2-4-2	Y	8	Y	Y	-	-	15	Y

3 Phase Fully Actuated With EV Preemption (Isolated)

NOTES

- Refer to "Roadway Standard Drawings NCDOT" dated July 2006 and "Standard Specifications for Roads and Structures" dated July 2006.
- Do not program signal for late night flashing operation unless otherwise directed by the Engineer.
- Phase 5 may be lagged.
- Set all detector units to presence mode.
- Locate new cabinet so as not to obstruct sight distance of vehicles turning right on red.
- Locate emergency vehicle preemption switch in Fire Department station.
- The Division Traffic Engineer will determine the Delay before Preempt and Preempt Dwell Min Green time for the emergency vehicle preemption timing.
- Program signal heads numbered 41 and 42 to clear to all red before going into preempt.

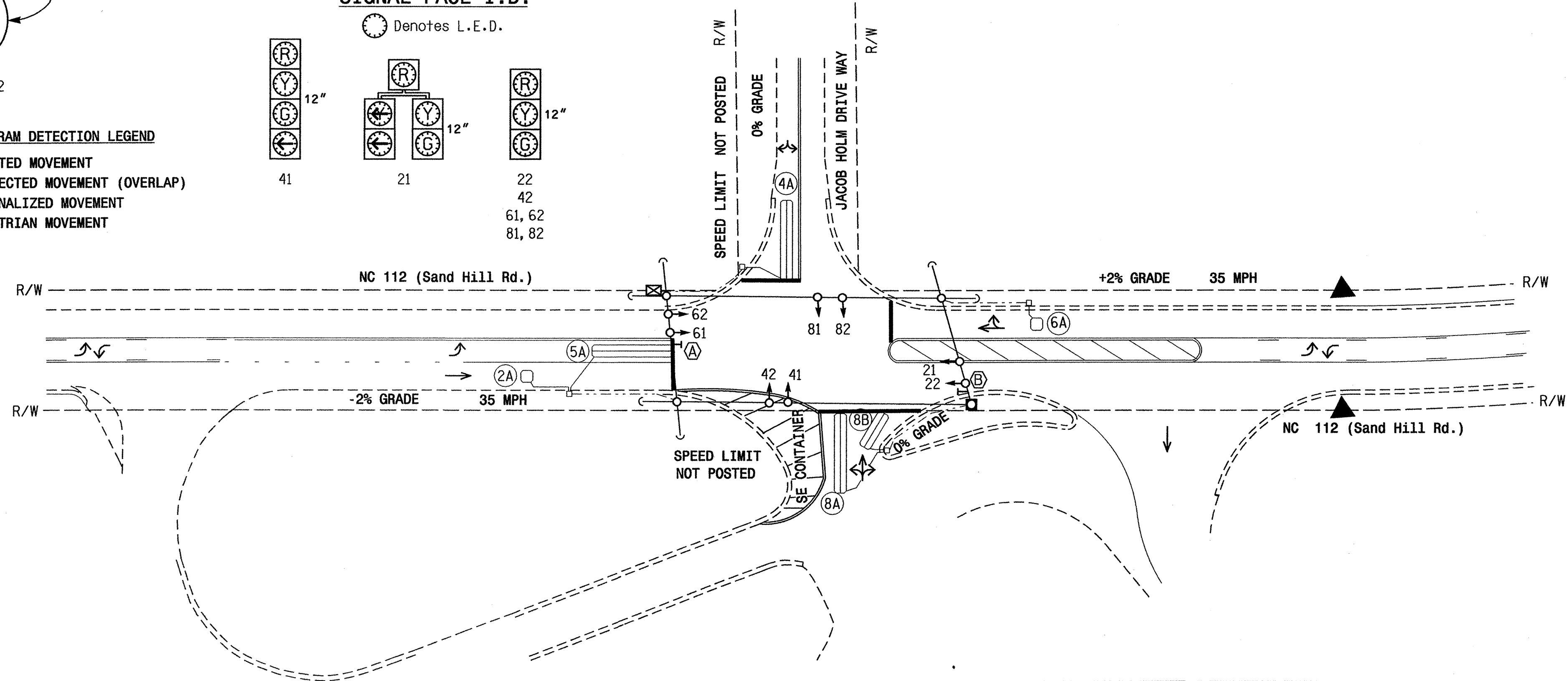

2070L TIMING CHART

FEATURE	PHASE				
	2	4	5	6	8
Min Green 1 *	10	7	7	10	7
Extension 1 *	3.0	1.0	1.0	3.0	1.0
Max Green 1 *	60	40	20	60	40
Yellow Clearance	4.0	3.0	3.0	3.7	3.0
Red Clearance	2.1	2.6	2.4	1.1	2.3
Walk 1 *	-	-	-	-	-
Don't Walk 1	-	-	-	-	-
Seconds Per Actuation *	-	-	-	-	-
Max Variable Initial *	-	-	-	-	-
Time Before Reduction *	-	-	-	-	-
Time To Reduce *	-	-	-	-	-
Minimum Gap	-	-	-	-	-
Recall Mode	MIN RECALL	-	-	MIN RECALL	-
Vehicle Call Memory	YELLOW	-	-	YELLOW	-
Dual Entry	-	ON	-	-	ON
Simultaneous Gap	ON	ON	ON	ON	ON

2070 EV PREEMPTION

FUNCTION	PRE 2
Interval 1 - Dwell Green	255
Interval 1 - Dwell Yellow	0.0 *
Interval 1 - Dwell Red	0.0 *
Interval 5 - Exit Green	1
Interval 5 - Yellow	0.0
Interval 5 - Red	0.0
Delay Time	** *
Min Green Before Pre	1
Ped Clear Before Pre	0
Yellow Clear Before Pre	0.0 *
Red Clear Before Pre	0.0 *
Dwell Min Time	** *
Enable Backup Protection	Y
Ped Clear Through Yellow	N

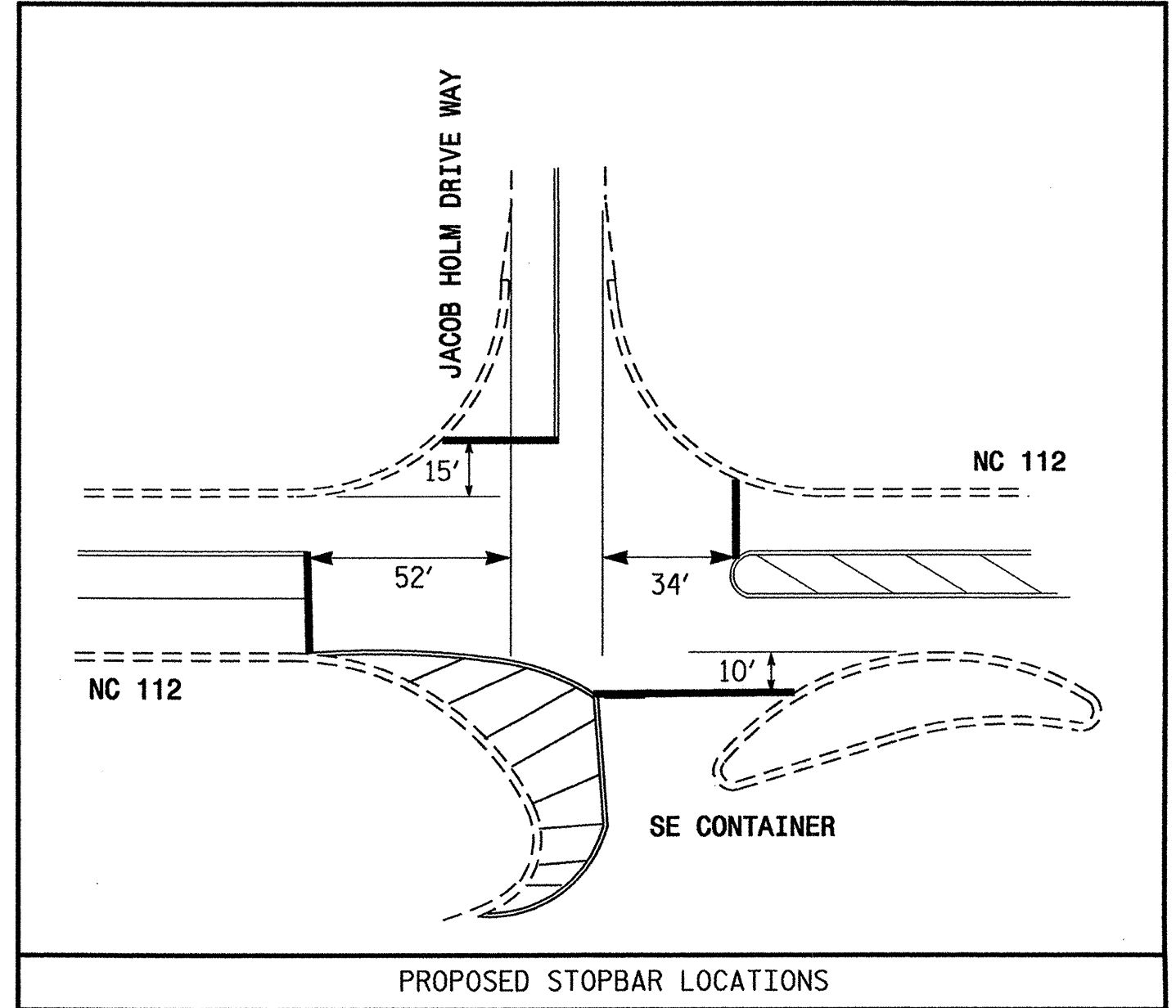

LEGEND

PROPOSED	EXISTING

* These values may be field adjusted. Do not adjust Min Green and Extension times for phases 2 and 6 lower than what is shown. Min Green for all other phases should not be lower than 4 seconds.

Signal Upgrade

Prepared in the Office of:

 STATE OF NORTH CAROLINA
 DEPARTMENT OF TRANSPORTATION
 Signal and Geometrics Section

NC 112 (Sand Hill Road) at Jacob Holm Drive/ Southeastern Container

Division 13 Buncombe County Enka

PLAN DATE: June 2007 REVIEWED BY: [Signature]
 PREPARED BY: Sterling REVIEWED BY: [Signature]

REVISIONS: [Table]
 INIT. DATE

SCALE: 1"=40'

122 N. McDowell St., Raleigh, NC 27603

SEAL: [Professional Engineer Seal]
 SIGNATURE: [Signature] DATE: 1/18/07
 SIG. INVENTORY NO. 13-1218

16-JUN-2007 15:53
 es-rhs-c:\prow\emerge\cupss\evanderinc_moving_atc\hcurcome_coh\31218-516.dwg_2007xxxx.dgn
 72 Emba

EDI MODEL 2010ECL CONFLICT MONITOR PROGRAMMING DETAIL

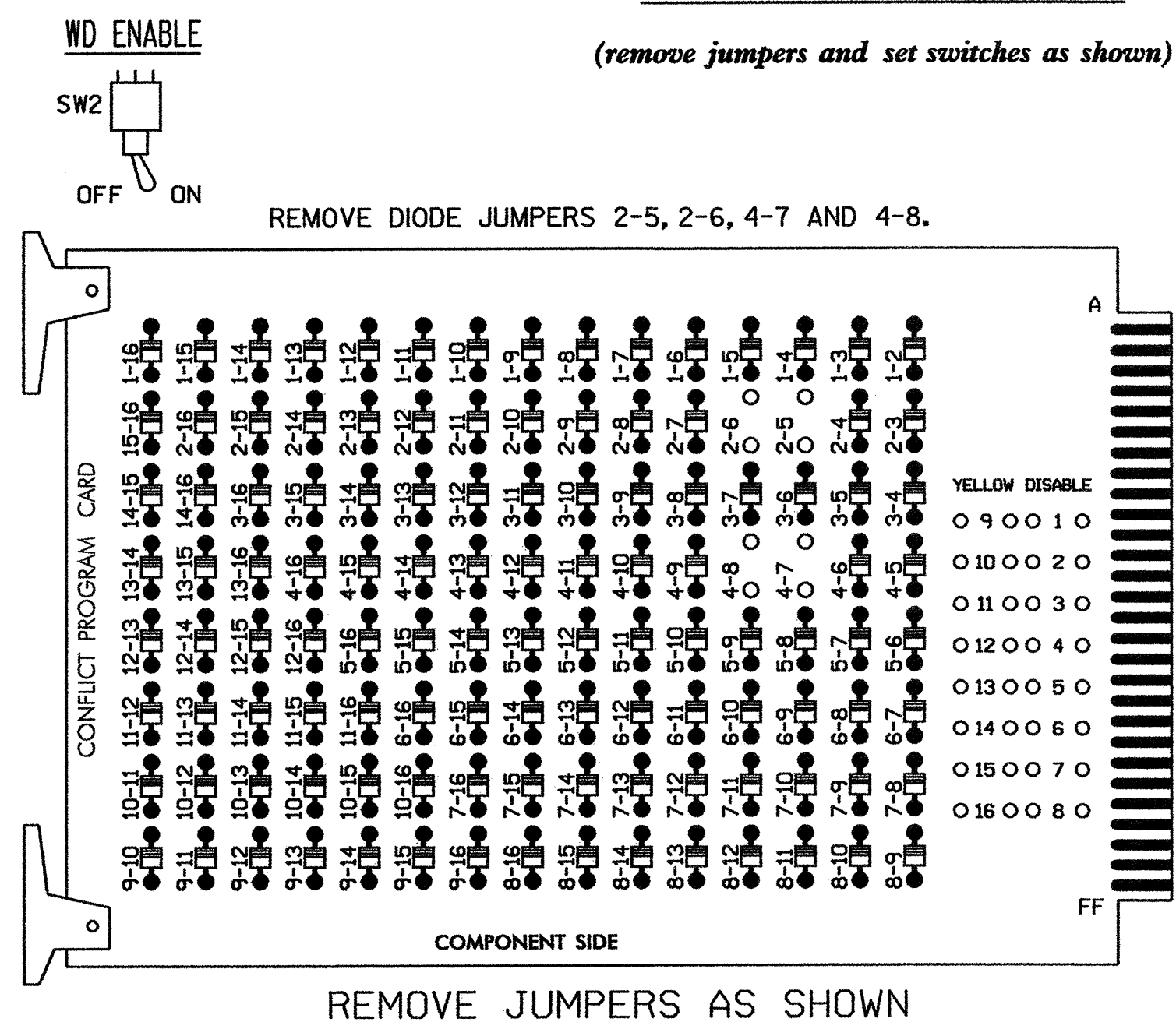

NOTES:

1. Card is provided with all diode jumpers in place. Removal of any jumper allows its channels to run concurrently.
2. Make sure jumpers SEL1-SEL5 are present on the monitor board.

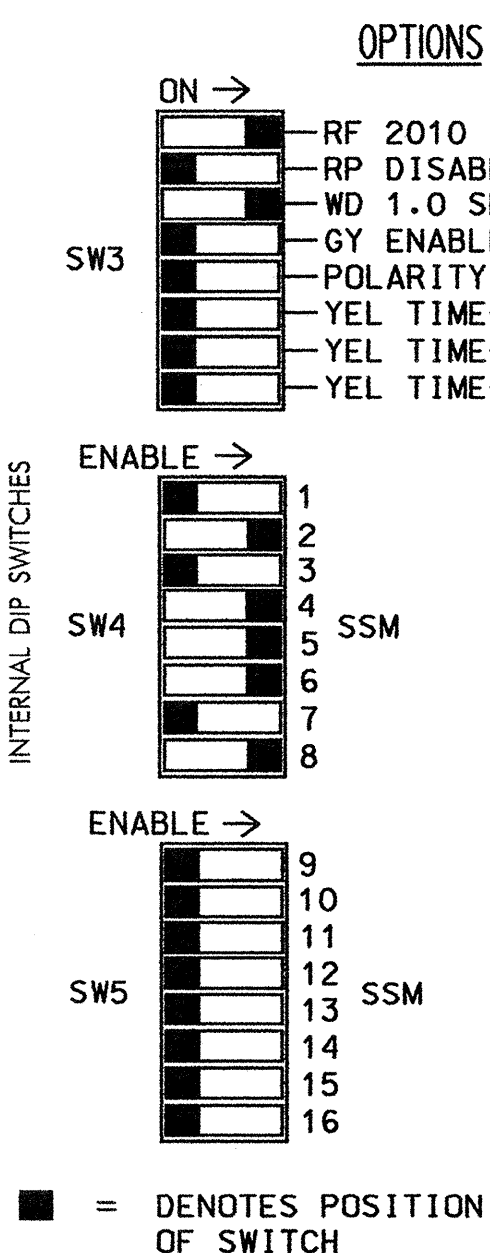

NOTES

1. To prevent "flash-conflict" problems, insert red flash program blocks for all unused vehicle load switches in the output file. Verify that signal heads flash in accordance with the Signal Plans.
2. Ensure that Red Enable is active at all times during normal operation. To prevent Red Failure on unused monitor channels, tie unused red monitor inputs 1,3, 7,9,10,11,12,13,14,15 & 16 to load switch AC+ per the cabinet manufacturer's instructions.
3. Program phases 2 and 6, on the controller unit, for Start-Up in Green.
4. Enable Simultaneous Gap-Out, on the controller unit, for all phases.
5. Program phases 4 and 8, on the controller unit, for Dual Entry.
6. Set all detector card channels to 'Presence' mode.

EQUIPMENT INFORMATION

CONTROLLER.....CONTRACTOR SUPPLIED 2070L
 CABINET.....CONTRACTOR SUPPLIED 332
 SOFTWARE.....ECONOLITE OASIS
 CABINET MOUNT.....BASE
 OUTPUT FILE POSITIONS...12
 LOAD SWITCHES USED.....S2,S2P**,S4,S5,S6,S7,S8
 PHASES USED.....2,4,5,6,7*,8
 OVERLAPS.....NONE

- * USED DURING PREEMPT ONLY
- ** USED FOR PREEMPT INDICATOR LAMP ONLY.

SIGNAL HEAD HOOK-UP CHART

LOAD SWITCH NO.	S1	S2	S2P	S3	S4	S4P	S5	S6	S6P	S7	S8	S8P
PHASE	1	2	2 PED	3	4	4 PED	5	6	6 PED	7	8	8 PED
SIGNAL HEAD NO.	NU	21,22	**	NU	41,42	NU	21	61,62	NU	41	81,82	NU
RED		128			101		*	134			107	
YELLOW		129			102			135		*	108	
GREEN		130			103			136			109	
RED ARROW												
YELLOW ARROW							132					
GREEN ARROW							133			124		

NU = Not Used

- * Denotes install load resistor. See Load Resistor Installation Detail this sheet.
- ** Install load switch in slot 'S2P' to be used as Preempt output to operate pilot light located in Fire Station. See 'Lamp Notes' on sheet 2 of 2.

INPUT FILE POSITION LAYOUT

(front view)

FILE	1	2	3	4	5	6	7	8	9	10	11	12	13	14
U	∅ 2	∅ 2	∅ 6	∅ 8	∅ 8	∅ 8	∅ 8	∅ 8	∅ 8	∅ 8	∅ 8	∅ 8	∅ 8	∅ 8
L	NOT USED	NOT USED	NOT USED	NOT USED	NOT USED	NOT USED	NOT USED	NOT USED	NOT USED	NOT USED	NOT USED	NOT USED	NOT USED	NOT USED
U	∅ 2	∅ 6	∅ 8	∅ 8	∅ 8	∅ 8	∅ 8	∅ 8	∅ 8	∅ 8	∅ 8	∅ 8	∅ 8	∅ 8
L	5A	6A	8A	8A	8A	8A	8A	8A	8A	8A	8A	8A	8A	8A
	5A	NOT USED	8B	8B	8B	8B	8B	8B	8B	8B	8B	8B	8B	8B

EX. : 1A, 2A, ETC. = LOOP NO.'S

FS = FLASH SENSE
 ST = STOP TIME
 PRE = PREEMPT

INPUT FILE CONNECTION & PROGRAMMING CHART

LOOP NO.	LOOP TERMINAL	INPUT FILE POS.	PIN NO.	INPUT ASSIGNMENT NO.	DETECTOR NO.	NEMA PHASE	CALL	EXTEND	FULL TIME DELAY	STRETCH TIME	DELAY TIME
2A	TB2-5,6	I2U	39	1	2	2	Y	Y			
4A	TB4-9,10	I6U	41	3	4	4	Y	Y			10
5A ¹	TB3-5,6	J2U	40	2	6	2	Y	Y			
	TB3-7,8	J2L	44	6	16	5	Y	Y			15
6A	TB3-9,10	J3U	64	26	36	6	Y	Y			
8A	TB5-9,10	J6U	42	4	8	8	Y	Y			10
8B	TB5-11,12	J6L	46	8	18	8	Y	Y			15

¹Add jumpers from TB3-5 to TB3-7, and from TB3-6 to TB3-8.

INPUT FILE POSITION LEGEND: J2L

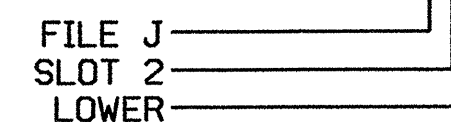

LOAD RESISTOR INSTALLATION DETAIL

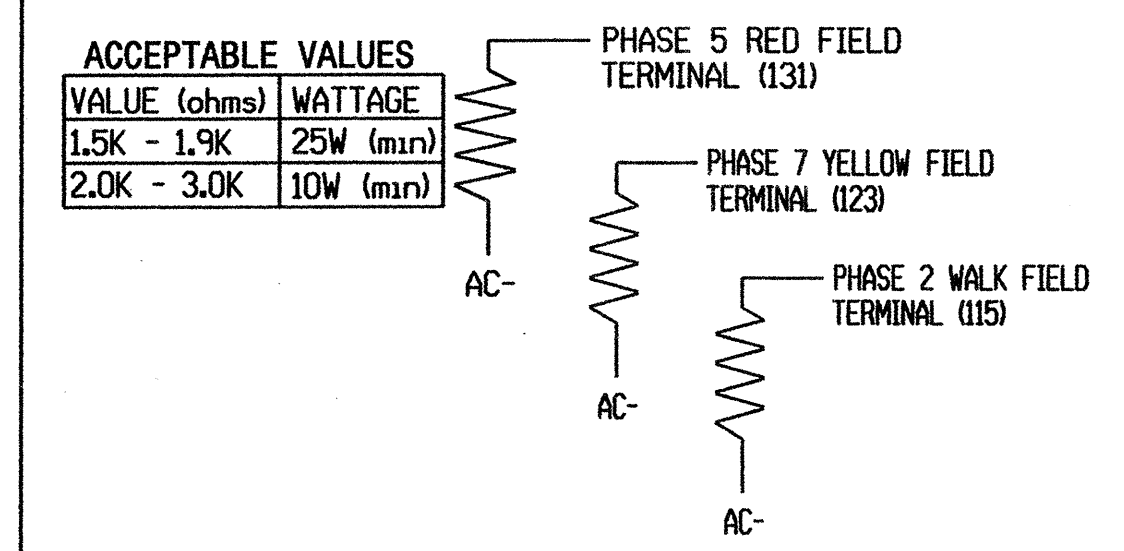

PREEMPT ONLY PHASE OMIT NOTE

From Main Menu press '2' (Phase Control). Then '1' (Phase Control Functions). Program Phase 7 for 'Omit Phase' and Phases 2, 4, 5, 6 and 8 for 'Startup Calls'. This is to prevent Phase 7 from being served when not in Preempt.

THIS ELECTRICAL DETAIL IS FOR THE SIGNAL DESIGN: 13-1218
 DESIGNED: JUNE 2007
 SEALED: 6/18/07
 REVISED: N/A

New Installation - Sheet 1 of 2

ELECTRICAL AND PROGRAMMING DETAILS FOR:

NC 112 (Sand Hill Road) at Jacob Holm Drive/Southeastern Container

Division 13 Buncombe County Enka

PLAN DATE: June 2007 REVIEWED BY: JEP

PREPARED BY: F.E. RUSS REVIEWED BY:

REVISIONS INIT. DATE

SIGNATURE DATE

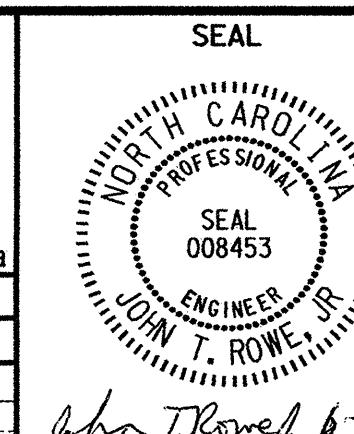
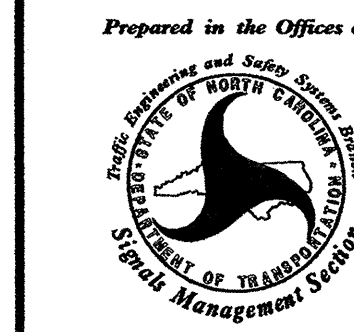

Sig. INVENTORY NO. 13-1218

EMERGENCY VEH. PREEMPTION PUSHBUTTON AND INDICATOR LAMP WIRING DETAIL

(wire push-button and lamp as shown below)

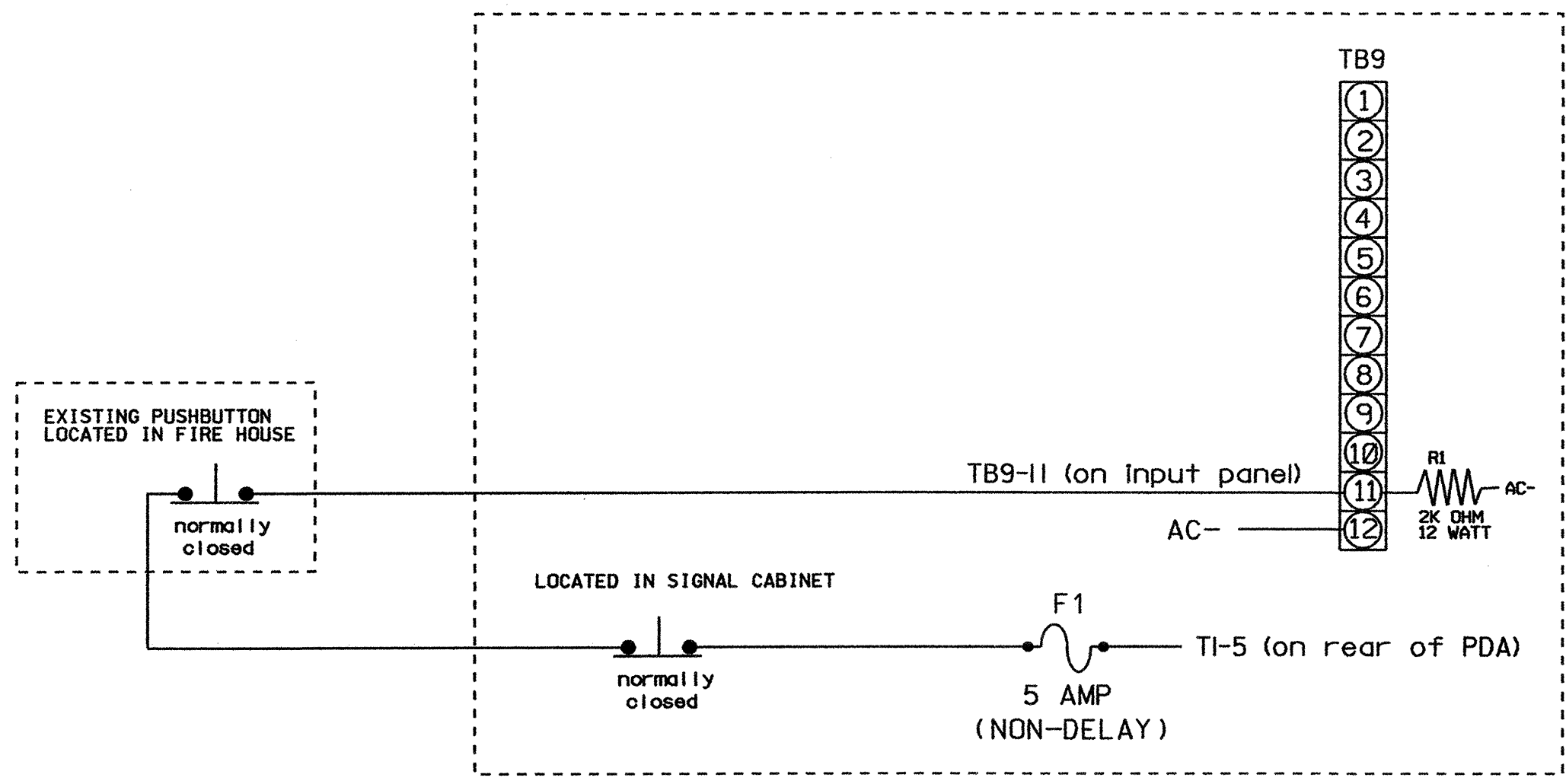

IMPORTANT!

1. Make sure AC isolator inserted in Slot J14L is set for inverted input. (Channel 2)
2. Connect terminal TB9-12B (on input panel) to AC neutral (jumper may need to be added).

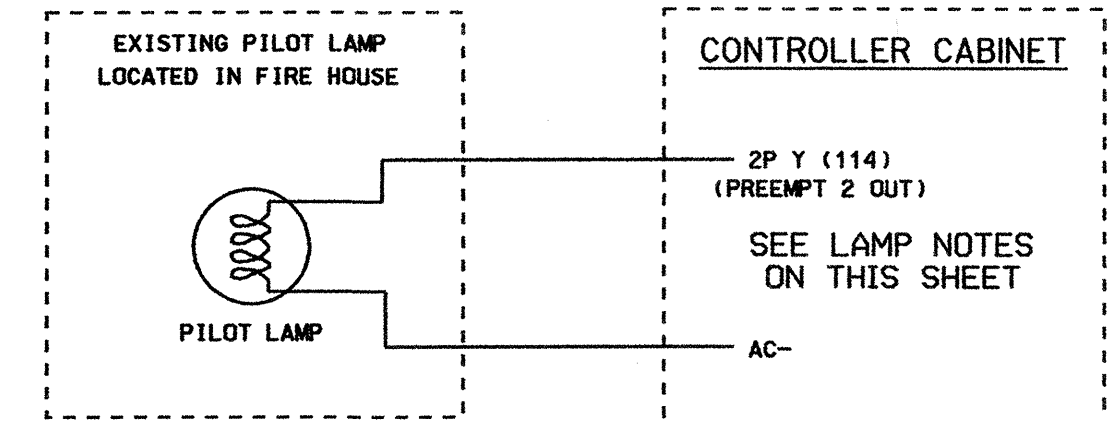

LAMP NOTES

In order for the pilot lamp in the fire house to function, make the following programming changes to Output No. 33:

1. Change the function of C1 pin 35 to be an output for Preempt 2. This is accomplished by the following:
 - A) From Main Menu select '6' (Outputs). Then select '1' (Output Assignments).
 - B) Scroll to C1 pin 35, Output No. 33. You will see that it is not enabled.
 - C) Scroll down to Preempt and input 'YES'. You will then be asked for a preempt number. Enter a '2' here.
 - D) The output is now assigned for PRE-2 output.
2. If field terminal 114 has a conflict monitor wire attached, remove, tape, and label wire.
3. Make sure load resistors are in place as shown in the 'Load Resistor Installation Detail' on sheet 1 of 2.
4. Install a loadswitch in Output File Slot S2P.

LOGICAL I/O PROCESSOR PROGRAMMING DETAIL FOR PREEMPT INDICATOR LAMP CONTROL

NOTE

When preempt delay time is used, Step 1 below is necessary to ensure the pilot lamp in the fire house will activate immediately after the push button is depressed:

STEP 1

From Main Menu: Press '6' (Outputs), then select '3' (Logical I/O Processor).

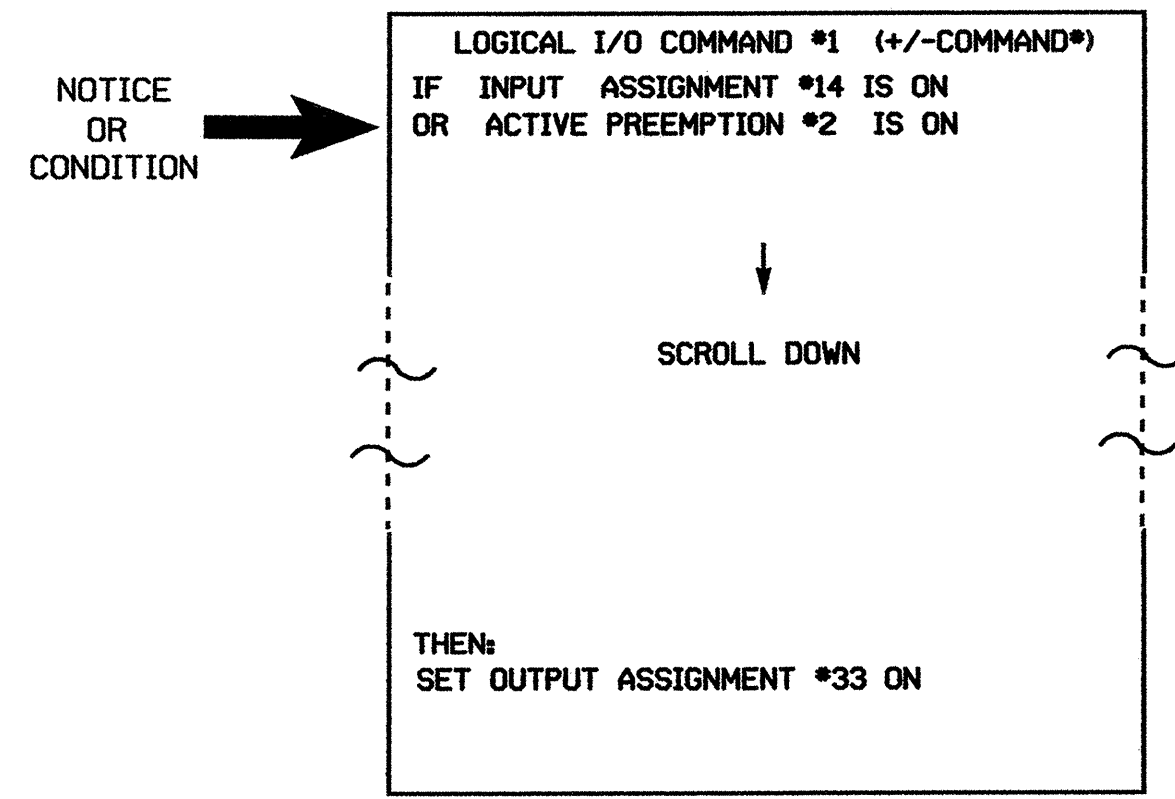

STEP 2

NOTE

In order for pilot lamp in fire house to deactivate immediately after ending preemption, program the following:

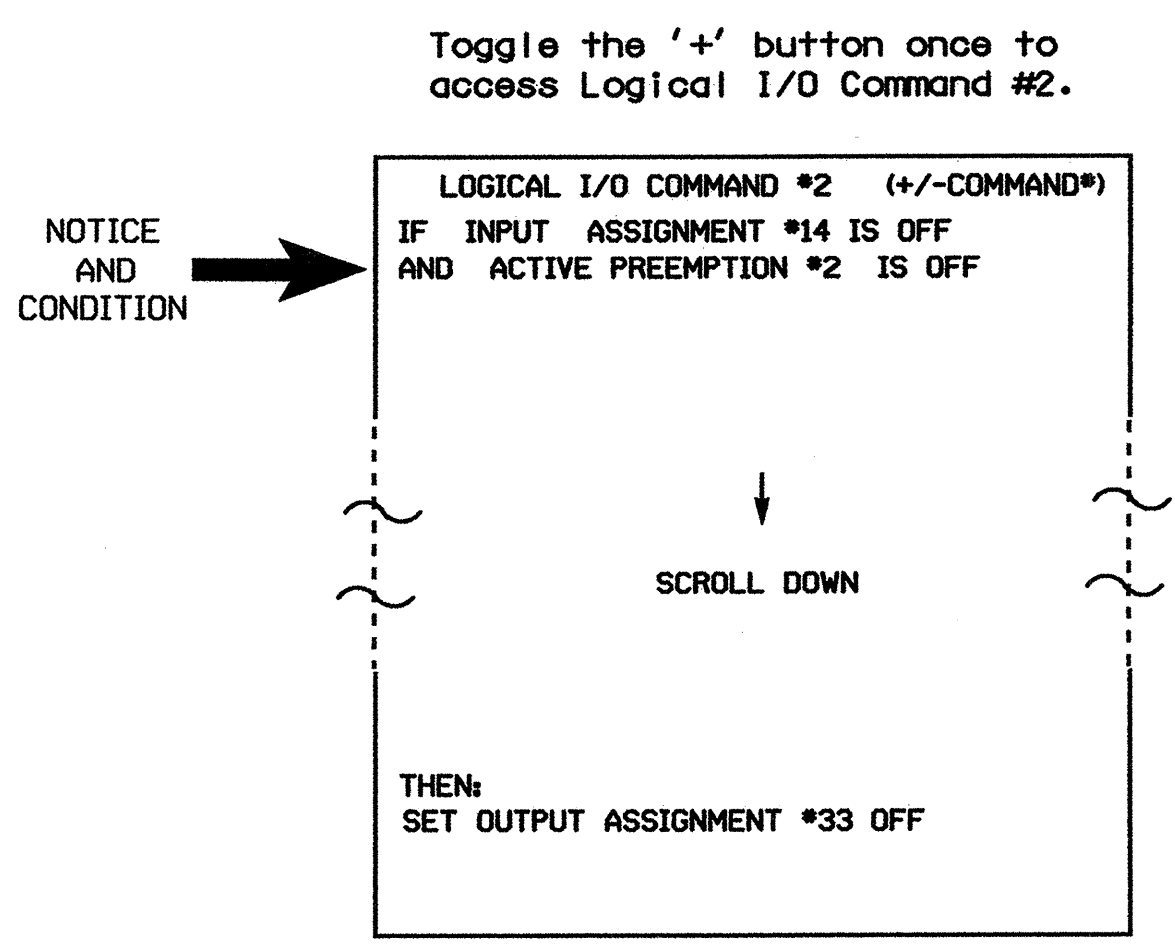

STEP 3

From Main Menu press '2' (Phase Control), then '1' (Phase Control Functions). Scroll to the bottom of the menu and enable logical processor (Act Logic 1-16) by flagging #1 and #2.

END OF PROGRAM.

EMERGENCY VEHICLE PREEMPTION PROGRAMMING DETAIL

(program controller as shown below)

From Main Menu press 'A' (Preemption), then '1' (Standard Preemptions). Press 'NEXT' to advance to Preemption #2.

PREEMPTION #2	INTERVAL/TIMING	SETTINGS (NEXT:1-10)	CLEAR/DWELL PHASES
1	255 0.0 0.0	X X	12345678910111213141516
2	0 0.0 0.0		
3	0 0.0 0.0		
4	0 0.0 0.0		
5	1 0.0 0.0	X X	

EXIT CALLS	OPTIONS
PRIORITY (Y/N TO SELECT)MED
DELAY TIMER (0-255 SEC)*
MIN GREEN BEFORE PRE (0= DEFAULT)	...1
PED CLEAR BEFORE PRE (0= DEFAULT)	...0
YELLOW CLEAR BEFORE PRE (0= DEFAULT)	...0
RED CLEAR BEFORE PRE (0= DEFAULT)	...0
DWELL MIN TIMER (0-255 SEC)*
DWELL MAX TIMER (0-OFF,1-255MIN)	...0
DWELL HOLD-OVER TIMER (0-255)	...0
LATCH CALL?Y
LINK TO NEXT PREEMPT?N
ENABLE BACKUP PROTECTION?Y
HOLD CLEAR 1 PHASES DURING DELAY?	...Y
FAST GREEN FLASH DWELL PHASES?N
PED CLEARANCE THROUGH YELLOW?N
INHIBIT OVERLAP GREEN EXTENSION?	...N
SERVICE DURING SOFTWARE FLASH?N
REST IN RED DURING DWELL INTERVAL?	..N
FLASH DWELL INTERVAL?N
ALLOW PEDS IN DWELL INTERVAL?N
RE-TIME DWELL INTERVAL?Y
OVERLAPS:	ABCDEFGHIJKLMNPO
DWELL INT FLASH YELLOW	
OMIT OVERLAPS:	

* Denotes timing to be determined in field.

THIS ELECTRICAL DETAIL IS FOR THE SIGNAL DESIGN: 12-1218
 DESIGNED: JUNE 2007
 SEALED: 6/18/07
 REVISED: N/A

New Installation - Sheet 2 of 2

	NC 112 (Sand Hill Road) at Jacob Holm Drive/Southeastern Container		SEAL 	
	Division 13 Buncombe County Enka			
	PLAN DATE: JUNE 2007 REVIEWED BY: JPP			
	PREPARED BY: F.E. RUSS REVIEWED BY:			
REVISIONS		INIT. DATE		
SIGNATURE: John T. Rowe 6-22-07			DATE	
SIG. INVENTORY NO. 13-1218				

21-JUN-2007 09:09 U:\wpc\wpc\pgrs\2070\dwgs\131218_sml.e 16:200706xx.dgn

**EDI MODEL MMU-16E
MALFUNCTION MANAGEMENT UNIT
PROGRAMMING DETAIL**
(program card and set switches as shown below)

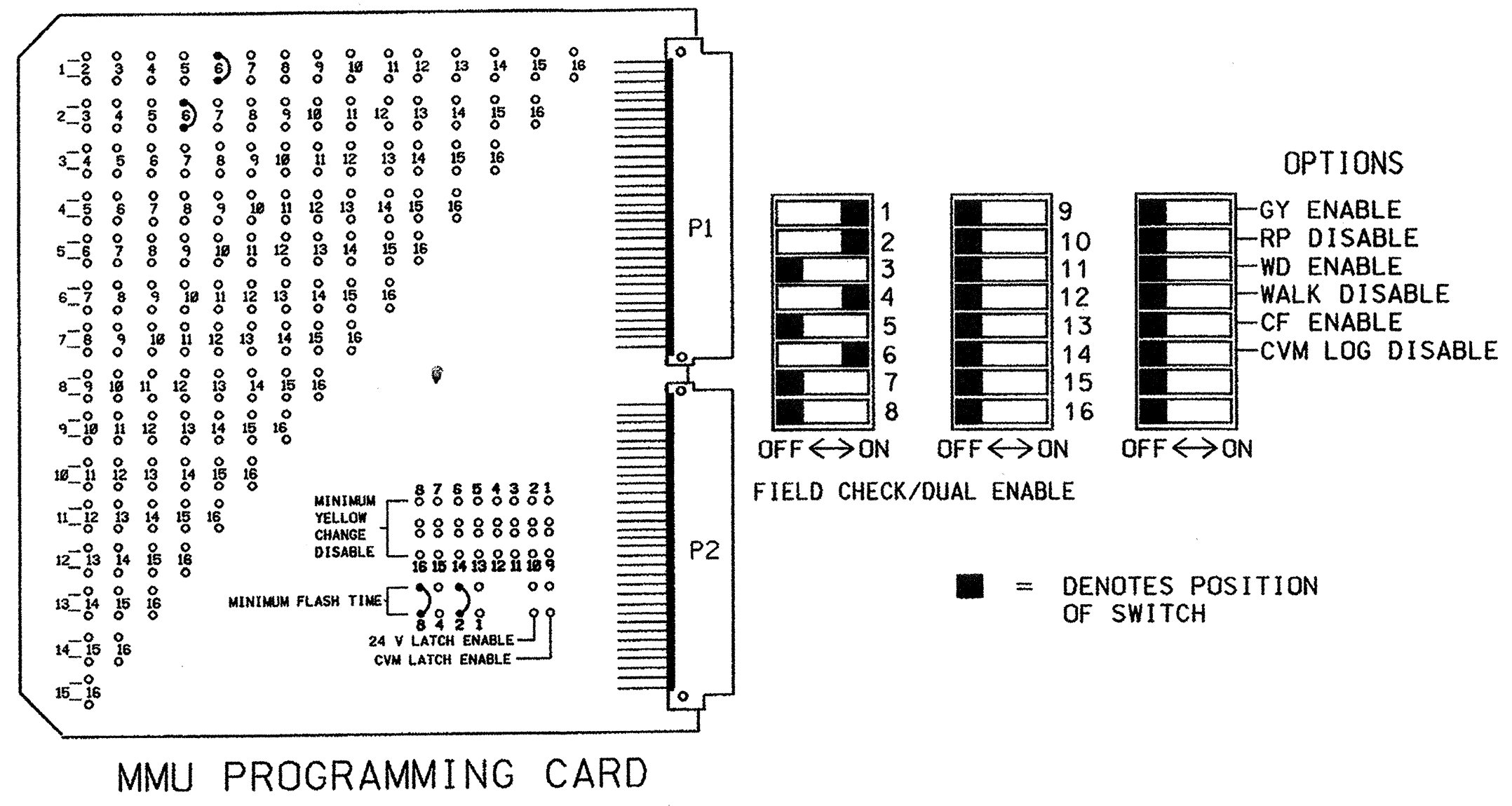

NOTES

1. TO PREVENT "FLASH-CONFLICT" PROBLEMS, WIRE ALL UNUSED LOAD SWITCHES TO FLASH RED. VERIFY THAT SIGNAL HEADS FLASH IN ACCORDANCE WITH THE SIGNAL PLANS.
2. TO PREVENT RED FAILURES ON UNUSED MONITOR CHANNELS, TIE UNUSED LOAD SWITCH RED OUTPUTS 3,5,7,8,9,10,11, & 12 TO LOAD SWITCH AC+ BY INSERTING A JUMPER PLUG IN THE UNUSED LOAD SWITCH SOCKET FROM PIN 1 (LS AC+) TO PIN 3 (RED OUT). MAKE SURE ALL FLASH TRANSFER RELAYS ARE IN PLACE.
3. PROGRAM CONTROLLER TO START UP IN PHASES 2 AND 6 GREEN.
4. SET POWER-UP FLASH TIME TO 10 SECONDS AND IMPLEMENT ON THE MALFUNCTION MANAGEMENT UNIT. SET CONTROLLER POWER-UP FLASH TIME TO 0 SECONDS.
5. ENABLE SIMULTANEOUS GAP-OUT FEATURE, ON CONTROLLER UNIT, FOR ALL PHASES.
6. PROGRAM DETECTORS IN ACCORDANCE WITH THE MANUFACTURER'S INSTRUCTIONS TO ACCOMPLISH THE DETECTION SCHEMES SHOWN ON THE SIGNAL DESIGN PLANS.
7. PROGRAM DETECTOR CALL DELAY AND EXTENSION TIMING ON THE CONTROLLER, UNLESS OTHERWISE SPECIFIED.
8. SET ALL DETECTOR CARD UNIT CHANNELS TO "PRESENCE" MODE.
9. PROGRAM PHASES 2 AND 6, ON CONTROLLER UNIT, FOR VOLUME DENSITY OPERATION.

FIELD CONNECTION HOOK-UP CHART

PHASE	1	2	3	4	5	6	7	8	2 PED	4 PED	6 PED	8 PED
SIGNAL HEAD NO.	42,61	21,22	NU	41,42	NU	61,62	NU	NU	NU	NU	NU	NU
GREEN		2G		4G		6G						
YELLOW		2Y		4Y		6Y						
RED	*	2R		4R		6R						
RED ARROW												
YELLOW ARROW	1Y											
GREEN ARROW	1G											

NU = NOT USED
 * DENOTES INSTALL LOAD RESISTOR. SEE LOAD RESISTOR INSTALLATION DETAIL THIS PAGE.

DETECTOR RACK SET-UP DETAIL

INSERT DETECTOR CARDS IN RACK ACCORDING TO THE DETAIL SHOWN BELOW. PARTICULAR DETECTOR CHANNELS WILL CALL PHASES INDICATED.

BIU	CH1	CH1	CH1	CH1	SLOT	SLOT	SLOT	SLOT	SLOT	SLOT	SLOT
	L 3	L 1	L 7	L 5							
	∅ 1	∅ 1	∅ 4	∅ 2	EMPTY	EMPTY	EMPTY	EMPTY	EMPTY	EMPTY	EMPTY
CH2	CH2	CH2	CH2	SLOT	SLOT	SLOT	SLOT	SLOT	SLOT	SLOT	
NOT USED	L 2	L 8	NOT USED								
	∅ 6	∅ 6	USED	EMPTY	EMPTY	EMPTY	EMPTY	EMPTY	EMPTY	EMPTY	

WIRE LOOPS TO TERMINALS ON LOOP PANEL AS SHOWN IN THE CHART BELOW

PROGRAM CONTROLLER DETECTORS ACCORDING TO THE SCHEDULE SHOWN IN THE CHART BELOW

ADD JUMPERS FROM: L1A TO L2A, AND L1B TO L2B

LOOP NO.	LOOP PANEL TERMINALS
1A	L1A, L1B L2A, L2B
1B	L3A, L3B L4A, L4B
2A	L5A, L5B L6A, L6B
4A	L7A, L7B
6A	L8A, L8B L9A, L9B L10A, L10B L11A, L11B L12A, L12B L13A, L13B L14A, L14B L15A, L15B L16A, L16B

NOTE
 BE SURE TO PROGRAM DETECTOR TYPES AND TIMERS (EXTEND AND DELAY) AS SHOWN ON THE SIGNAL PLANS.

CONTROLLER DETECTOR NO.	FUNCTION	TIMING	
		FEATURE	TIME(SEC)
1	∅ 1	DELAY	15
* 2	∅ 6	DELAY	3
3	∅ 1	DELAY	15
4			
5	∅ 2		
6			
7	∅ 4	DELAY	3
8	∅ 6		
9			
10			
11			
12			
13			
14			
15			
16			

* THIS DETECTOR IS EQUIPPED WITH DELAY AND EXTEND TIMERS. PROGRAM THE TIMING REQUIRED FOR THIS DETECTOR CHANNEL ON THE DETECTOR UNIT, NOT THE CONTROLLER.

EQUIPMENT INFORMATION

CONTROLLER.....EAGLE EPAC300(M42)
 CABINETEAGLE TF5012TNC01 **TS-2**
 CABINET MOUNT.....BASE
 LOADBAY POSITIONS.....12
 LOAD SWITCHES USED.....1,2,4,6
 PHASES USED.....1,2,4,6
 OLA.....NOT USED
 OLB.....NOT USED
 OLC.....NOT USED
 OLD.....NOT USED

LOAD SWITCH ASSIGNMENT DETAIL

(program controller according to schedule in chart below)

LOAD SWITCH NUMBER	FUNCTION
1	∅ 1
2	∅ 2
3	∅ 3
4	∅ 4
5	∅ 5
6	∅ 6
7	∅ 7
8	∅ 8
9	2 PED
10	4 PED
11	6 PED
12	8 PED

LOAD RESISTOR INSTALLATION DETAIL

ACCEPTABLE VALUES

VALUE (ohms)	WATTAGE
1.5K - 1.9K	25W (min)
2.0K - 3.0K	10W (min)

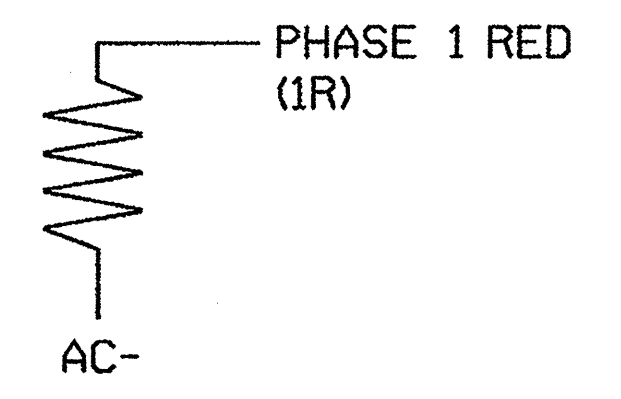

NOTE: THE PURPOSE OF THIS RESISTOR IS TO LOAD THE CHANNEL RED MONITOR INPUT IN ORDER FOR THE MALFUNCTION MANAGEMENT UNIT TO USE THE FULL SIGNAL SEQUENCE MONITORING CAPABILITY ON PHASES THAT DO NOT USE THE RED DISPLAY IN THE FIELD.

THIS ELECTRICAL DETAIL IS FOR THE SIGNAL DESIGN: 13-0663T1
 DESIGNED: DECEMBER 2005
 SEALED: 03/13/06
 REVISED: NA

SIGNAL UPGRADE - Sheet 1 of 2

ELECTRICAL AND PROGRAMMING DETAILS FOR:

Prepared in the Office of:

 122 N. McDowell St., Raleigh, NC 27603

NC 112
 (SAND HILL ROAD / SARDIS ROAD)
 AT
 SR 3412 (SAND HILL ROAD)
 BUNCOMBE COUNTY S. OF ASHEVILLE

PLAN DATE: MARCH 2006
 PREPARED BY: PAUL MARAK
 DIVISION 13

REVIEWED BY: T. J. J...
 REVIEWED BY: ...

SEAL
 NORTH CAROLINA PROFESSIONAL ENGINEER
 SEAL 022013
 GEORGE C. BROWN

SIG. INVENTORY NO. 13-0663T1

EAGLE EPAC300 (M42) CONTROLLER RING CONFIGURATION DETAIL

(program controller as shown below)

NOTE:

BEFORE PROGRAMMING CONTROLLER, BE SURE TO LOAD DEFAULT PARAMETERS.

SELECT (4) FROM MAIN MENU

EPAC UNIT DATA		PRESS # DESIRED
1- STARTUP & MISC	6- ALT SEQUENCES	
2- REMOTE FLASH	7- PORT 1 DATA	
3- OVERLAP STANDARD	8- I/O MISC	
4- OVERLAP SPECIAL	9- SIG DRV OUT	
5- RING STRUCTURE		
		F- PRIOR MENU

EPAC RING STRUCTURE		(0-NO / 1-YES)
PHASE: 1	RING: 1	NXT PHS: 3
CONCUR PHS: 100011000 0000000		
PHS/CHN: 123456789 0123456789 01234		
VEH CHN(S): 100000000 0000000000 00000		
PED CHN(S): 000000000 0000000100 00000		
		A-UP B-DN D-DspChn E-EDIT F-PRIOR MENU

EPAC RING STRUCTURE		(0-NO / 1-YES)
PHASE: 2	RING: 1	NXT PHS: 1
CONCUR PHS: 010011000 0000000		
PHS/CHN: 123456789 0123456789 01234		
VEH CHN(S): 010000000 0000000000 00000		
PED CHN(S): 000000001 0000000000 00000		
		A-UP B-DN D-DspChn E-EDIT F-PRIOR MENU

EPAC RING STRUCTURE		(0-NO / 1-YES)
PHASE: 3	RING: 1	NXT PHS: 4
CONCUR PHS: 001000110 0000000		
PHS/CHN: 123456789 0123456789 01234		
VEH CHN(S): 001000000 0000000000 00000		
PED CHN(S): 000000000 0000000010 00000		
		A-UP B-DN D-DspChn E-EDIT F-PRIOR MENU

EPAC RING STRUCTURE		(0-NO / 1-YES)
PHASE: 4	RING: 1	NXT PHS: 2
CONCUR PHS: 000100110 0000000		
PHS/CHN: 123456789 0123456789 01234		
VEH CHN(S): 000100000 0000000000 00000		
PED CHN(S): 000000000 1000000000 00000		
		A-UP B-DN D-DspChn E-EDIT F-PRIOR MENU

EPAC RING STRUCTURE		(0-NO / 1-YES)
PHASE: 5	RING: 2	NXT PHS: 6
CONCUR PHS: 110010000 0000000		
PHS/CHN: 123456789 0123456789 01234		
VEH CHN(S): 000010000 0000000000 00000		
PED CHN(S): 000000000 0000000001 00000		
		A-UP B-DN D-DspChn E-EDIT F-PRIOR MENU

EPAC RING STRUCTURE		(0-NO / 1-YES)
PHASE: 6	RING: 2	NXT PHS: 7
CONCUR PHS: 110001000 0000000		
PHS/CHN: 123456789 0123456789 01234		
VEH CHN(S): 000001000 0000000000 00000		
PED CHN(S): 000000000 0100000000 00000		
		A-UP B-DN D-DspChn E-EDIT F-PRIOR MENU

EPAC RING STRUCTURE		(0-NO / 1-YES)
PHASE: 7	RING: 2	NXT PHS: 8
CONCUR PHS: 001100100 0000000		
PHS/CHN: 123456789 0123456789 01234		
VEH CHN(S): 000000100 0000000000 00000		
PED CHN(S): 000000000 0000000000 10000		
		A-UP B-DN D-DspChn E-EDIT F-PRIOR MENU

EPAC RING STRUCTURE		(0-NO / 1-YES)
PHASE: 8	RING: 2	NXT PHS: 5
CONCUR PHS: 001100010 0000000		
PHS/CHN: 123456789 0123456789 01234		
VEH CHN(S): 000000010 0000000000 00000		
PED CHN(S): 000000000 0010000000 00000		
		A-UP B-DN D-DspChn E-EDIT F-PRIOR MENU

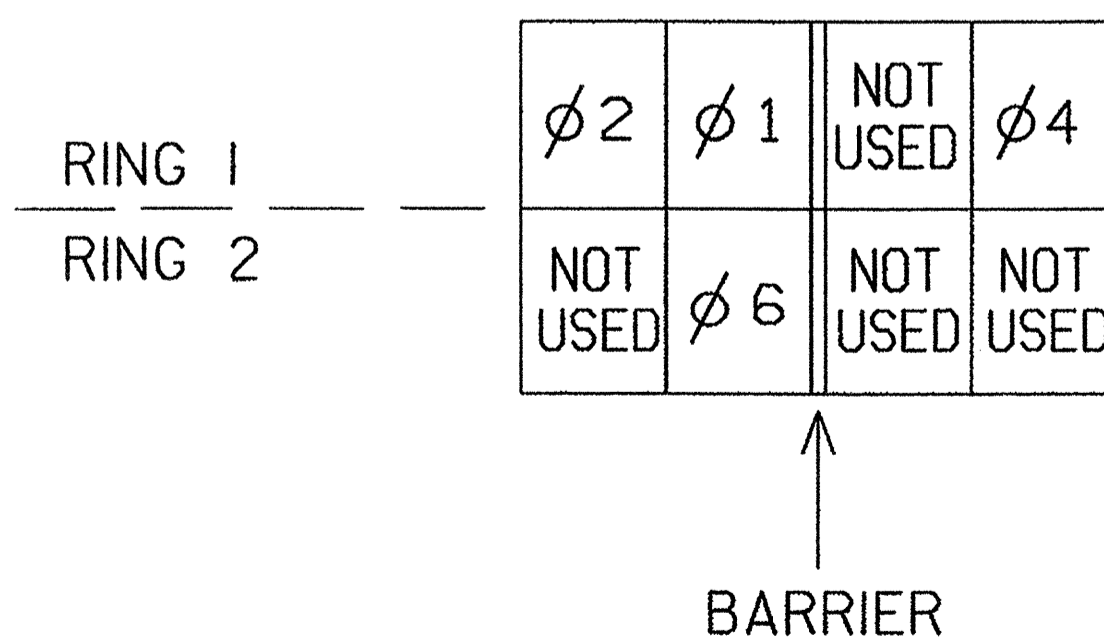

end of programming

DUAL-QUAD WITH PHASES 1 & 2 ROTATED



THIS ELECTRICAL DETAIL IS FOR THE SIGNAL DESIGN: 13-0663T1
DESIGNED: DECEMBER 2005
SEALED: 03/13/06
REVISED: NA

SIGNAL UPGRADE - Sheet 2 of 2

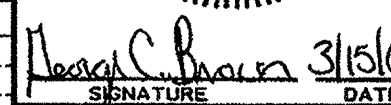
 <small>122 N. McDowell St., Raleigh, NC 27603</small>	NC 112 (SAND HILL ROAD / SARDIS ROAD) AT SR 3412 (SAND HILL ROAD)		SEAL 
	<small>DIVISION 13 BUNCOMBE COUNTY S. OF ASHEVILLE</small>		 <small>DATE</small>
	<small>PLAN DATE: MARCH 2006</small>	<small>REVIEWED BY: T. J. [Signature]</small>	
	<small>PREPARED BY: PAUL MARAK</small>	<small>REVIEWED BY:</small>	
<small>REVISIONS</small>		<small>INIT.</small>	<small>DATE</small>

13-MAR-2006 08:24
c:\p1\sig\epac300\epac300.dgn
p1000000

PHASING DIAGRAM

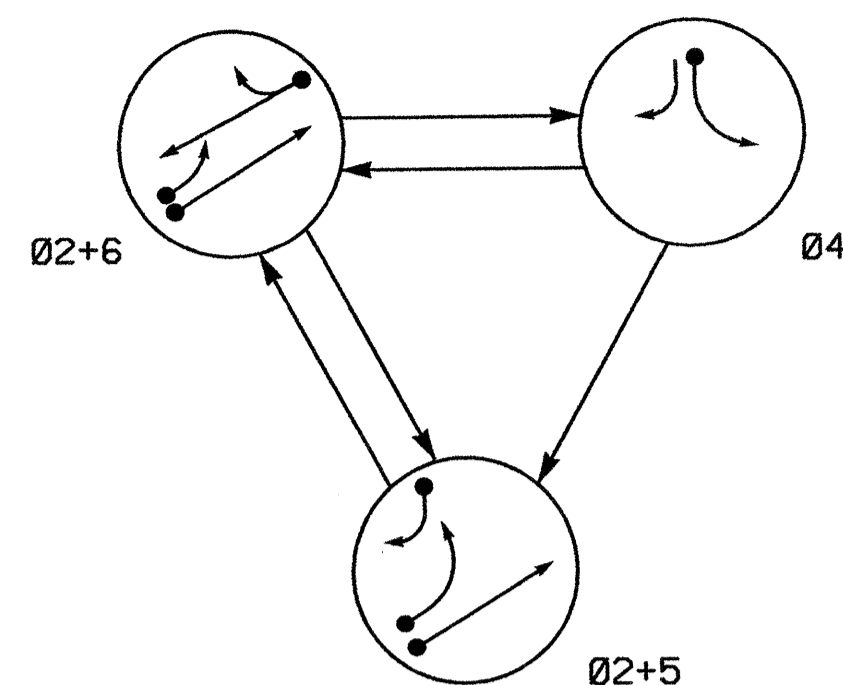

TABLE OF OPERATION

SIGNAL FACE	PHASE			
	Ø 2+5	Ø 2+6	Ø 4	Ø 2+5
21	G	R	Y	
22, 23	G	R	Y	
41, 43	R	G	R	
42	R	G	R	
61, 62, 63	R	G	Y	

2070L LOOP & DETECTOR INSTALLATION

LOOP	INDUCTIVE LOOPS			DETECTOR PROGRAMMING								
	SIZE (FT)	DISTANCE FROM STOPBAR (FT)	TURNS	NEW LOOP	PHASE	CALLING	EXTENSION	FULL TIME DELAY	STRETCH TIME	DELAY TIME	SYSTEM LOOP	NEW CARD
2A	6X6	300	5	Y	2	Y	Y	-	-	-	-	-
4A	6X40	0	2-4-2	-	4	Y	Y	-	-	3	-	-
5A	6X40	0	2-4-2	Y	5	Y	Y	Y	-	15	-	-
5B	6X40	0	2-4-2	-	5	Y	Y	-	-	15	-	-
6A	6X6	300	5	Y	6	Y	Y	-	-	-	-	-

3 Phase Fully Actuated (Isolated)

NOTES

1. Refer to "Roadway Standard Drawings NCDOT" dated July 2006 and "Standard Specifications for Roads and Structures" dated July 2006.
2. Do not program signal for late night flashing operation unless otherwise directed by the Engineer.
3. Phase 5 may be lagged.
4. Reposition existing signal heads numbered 61 and 62.
5. Set all detector units to presence mode.

PHASING DIAGRAM DETECTION LEGEND

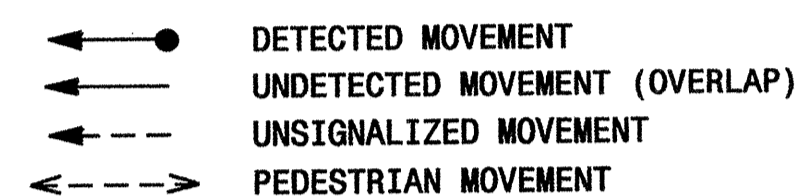

SIGNAL FACE I.D.

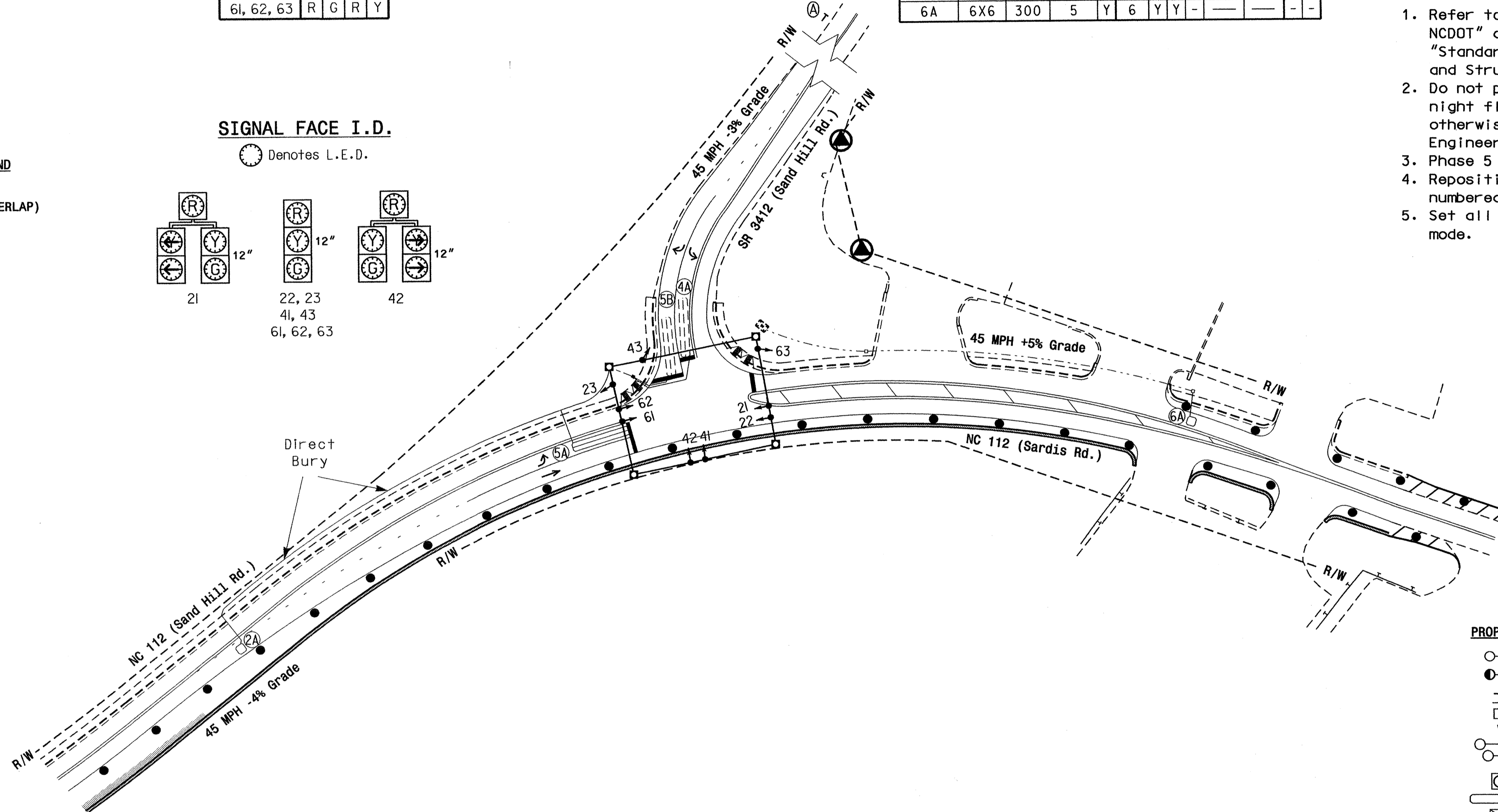
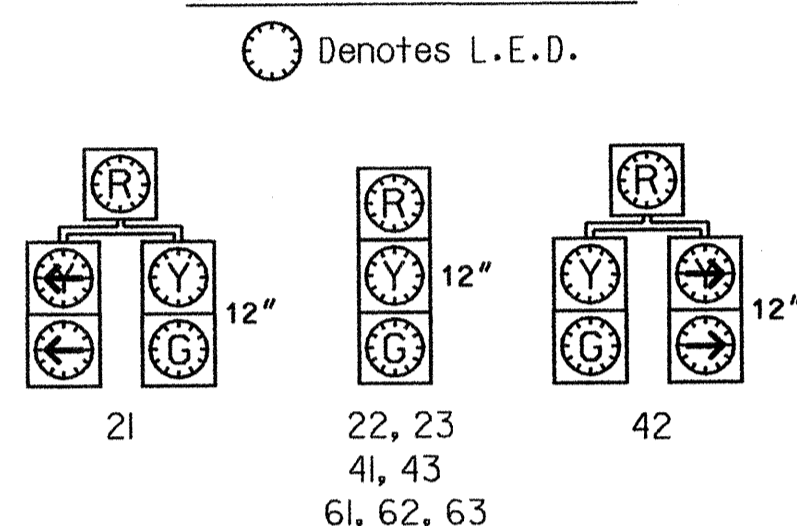

LEGEND

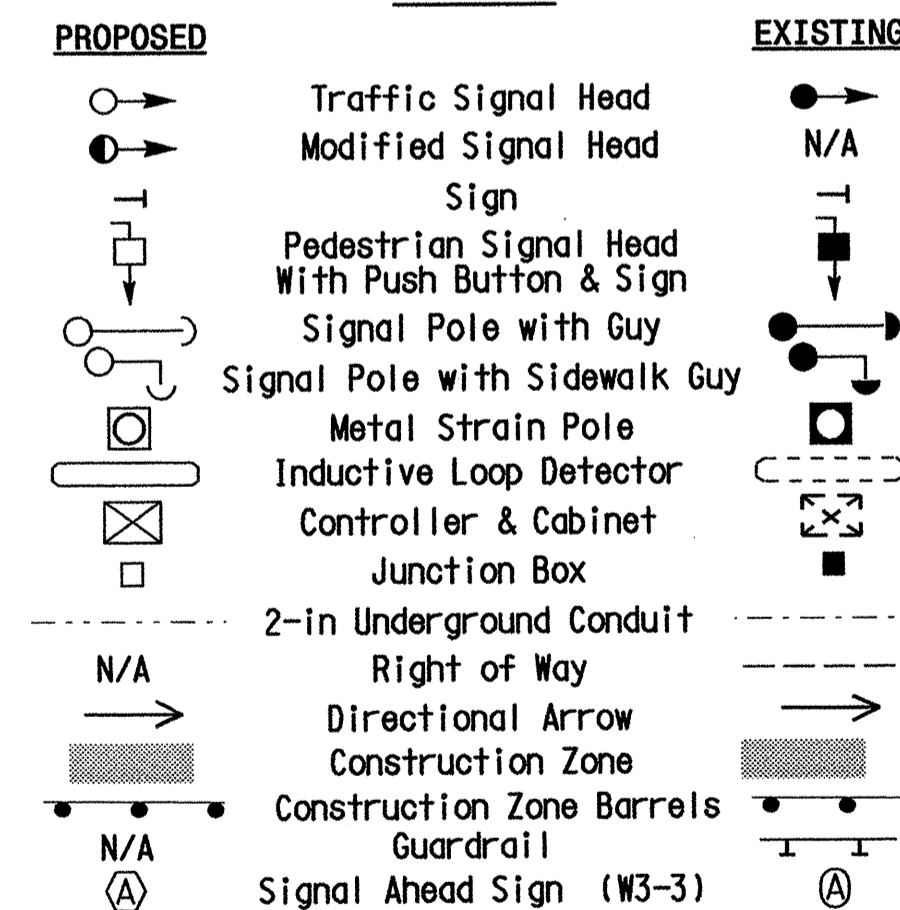

2070L TIMING CHART

FEATURE	PHASE			
	2	4	5	6
Min Green 1 *	12	7	7	12
Extension 1 *	6.0	2.0	2.0	6.0
Max Green 1 *	60	20	15	60
Yellow Clearance	4.9	3.0	3.0	4.1
Red Clearance	1.1	1.9	2.1	1.0
Walk 1 *	-	-	-	-
Don't Walk 1	-	-	-	-
Seconds Per Actuation *	2.5	-	-	2.5
Max Variable Initial *	34	-	-	34
Time Before Reduction *	15	-	-	15
Time To Reduce *	45	-	-	45
Minimum Gap	3.0	-	-	3.0
Recall Mode	MIN RECALL	-	-	MIN RECALL
Vehicle Call Memory	YELLOW	-	-	YELLOW
Dual Entry	-	-	-	-
Simultaneous Gap	ON	ON	ON	ON

* These values may be field adjusted. Do not adjust Min Green and Extension times for phases 2 and 6 lower than what is shown. Min Green for all other phases should not be lower than 4 seconds.

Signal Upgrade Temporary Design 3

Prepared in the Office of:

NC 112 (Sand Hill Road/Sardis Road) at SR 3412 (Sand Hill Road)
 Division 13 Buncombe County South of Asheville
 PLAN DATE: Dec. 2005 PREPARED BY: Sterling REVIEWED BY:
 122 N. McDowell St., Raleigh, NC 27603
 SCALE: 1"=50'
 REVISIONS: _____ INIT. DATE: _____

 SIGNATURE: _____ DATE: 3/13/06
 SIG. INVENTORY NO. 13-066313

EDI MODEL 2010ECL CONFLICT MONITOR

PROGRAMMING DETAIL

WD ENABLE

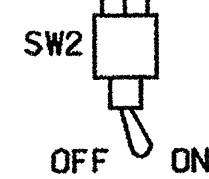

(remove jumpers and set switches as shown)

REMOVE DIODE JUMPERS 2-5 AND 2-6.

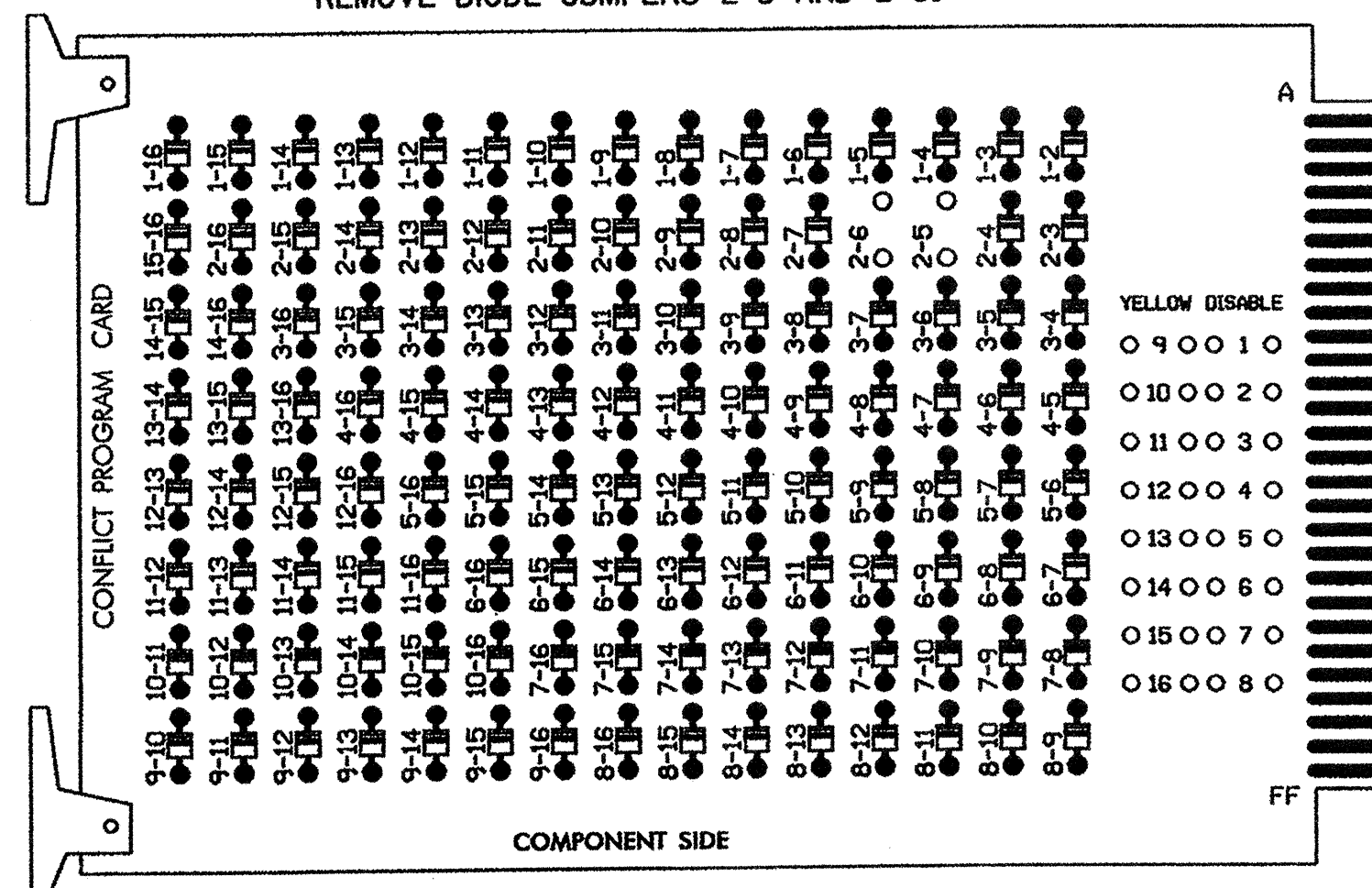

REMOVE JUMPERS AS SHOWN

OPTIONS

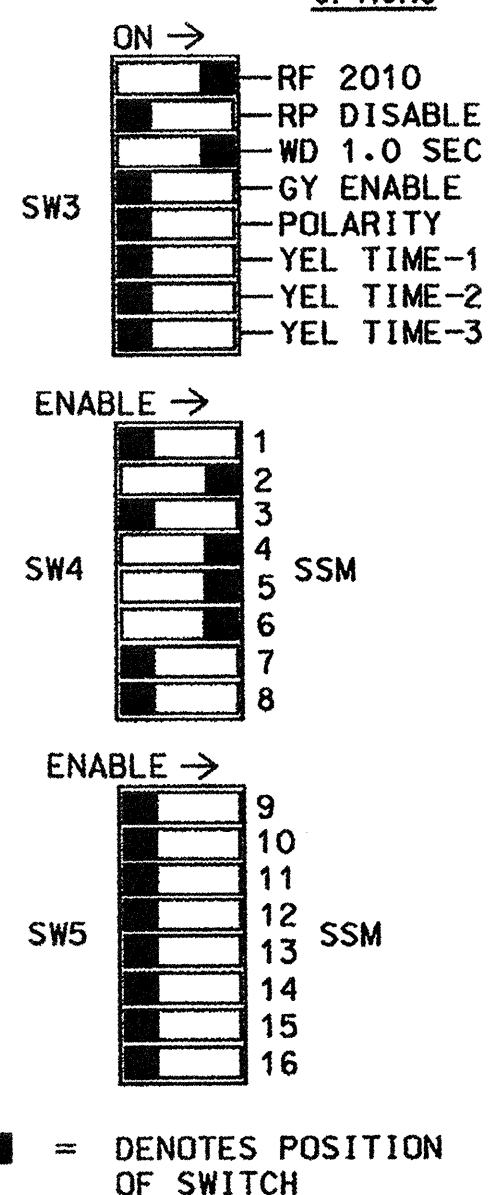

NOTES:

- Card is provided with all diode jumpers in place. Removal of any jumper allows its channels to run concurrently.
- Make sure jumpers SEL1-SEL5 are present on the monitor board.

NOTES

- To prevent "flash-conflict" problems, insert red flash program blocks for all unused vehicle load switches in the output file. The installer shall verify that signal heads flash in accordance with the Signal Plans.
- To prevent red failures on unused monitor channels, see Red Monitor Board Programming Detail this sheet.
- Program phases 2 and 6, on the controller unit, for Start Up In Green.
- Enable Simultaneous Gap-Out, on the controller unit, for all phases.
- Program phases 2 and 6, on the controller unit, for Variable Initial and Gap Reduction.

SIGNAL HEAD HOOK-UP CHART

LOAD SWITCH NO.	S1	S2	S2P	S3	S4	S4P	S5	S6	S6P	S7	S8	S8P
PHASE	1	2	2 PED	3	4	4 PED	5	6	6 PED	7	8	8 PED
SIGNAL HEAD NO.	NU	21,22 23	NU	NU	41,42 43	NU	21,42	61,62 63	NU	NU	NU	NU
RED		128			101		*	134				
YELLOW		129			102			135				
GREEN		130			103			136				
RED ARROW												
YELLOW ARROW							132					
GREEN ARROW							133					

NU = Not Used

* Denotes install load resistor. See load resistor installation detail this sheet.

EQUIPMENT INFORMATION

CONTROLLER.....EAGLE TYPE 2070L
 CABINET.....McCain/CONTROL TECHNOLOGIES
 (DWG.NO. 9500-332-NC DOT)
 SOFTWARE.....ECONOLITE OASIS
 CABINET MOUNT.....BASE
 OUTPUT FILE POSITIONS...12
 LOAD SWITCHES USED.....S2,S4,S5,S6
 PHASES USED.....2,4,5,6
 OVERLAPS.....NONE

INPUT FILE POSITION LAYOUT

(front view)

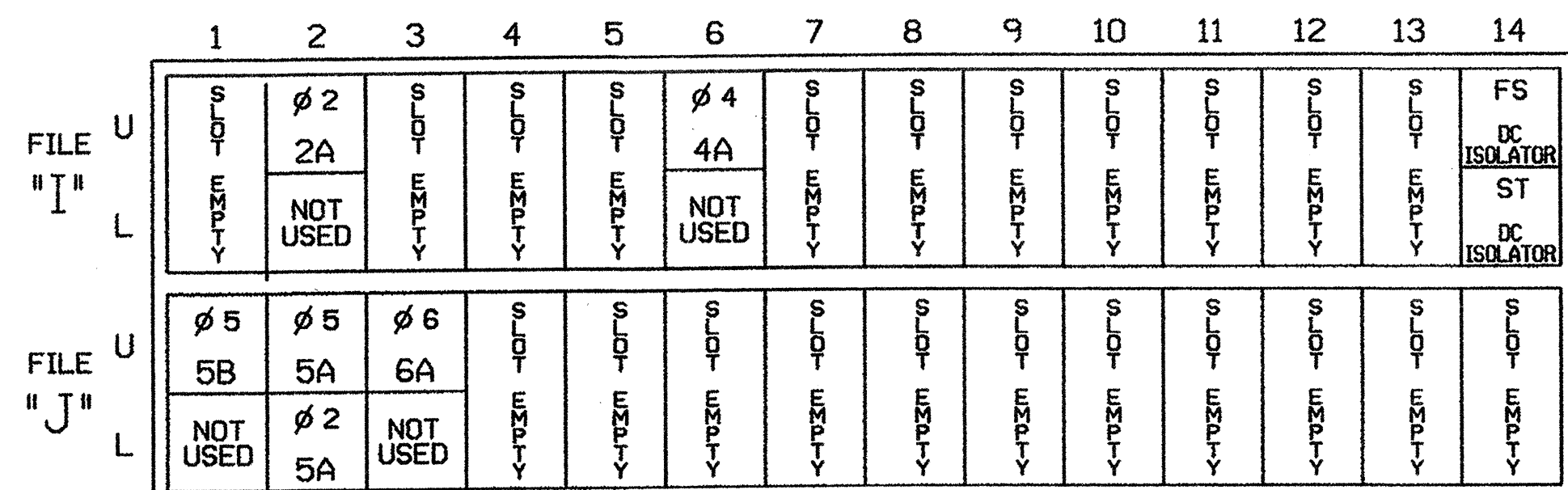

EX.: 1A, 2A, ETC. = LOOP NO.'S

FS = FLASH SENSE
 ST = STOP TIME

INPUT FILE CONNECTION & PROGRAMMING CHART

LOOP NO.	LOOP TERMINAL	INPUT FILE POS.	PIN NO.	INPUT ASSIGNMENT NO.	DETECTOR NO.	NEMA PHASE	CALL	EXTEND	FULL TIME DELAY	STRETCH TIME	DELAY TIME
2A	TB2-5,6	I2U	39	1	2	2	Y	Y			
4A	TB4-9,10	I6U	41	3	4	4	Y	Y			3
5B	TB3-1,2	J1U	55	17	5	5	Y	Y			15
5A	TB3-5,6	J2U	40	2	6	5	Y	Y			15
	TB3-7,8	J2L	44	6	16	2	Y	Y	Y		3
6A	TB3-9,10	J3U	64	26	36	6	Y	Y			

1 Add jumpers from TB3-5 to TB3-7, and from TB3-6 to TB3-8.

INPUT FILE POSITION LEGEND: J2L

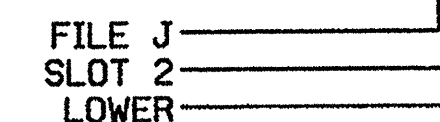

THIS ELECTRICAL DETAIL IS FOR THE SIGNAL DESIGN: 13-0663T2, 13-0663T3, AND 13-0663
 DESIGNED: December 2005
 SEALED: 03/13/06
 REVISED: NA

RED MONITOR BOARD PROGRAMMING

(position jumpers as shown below)

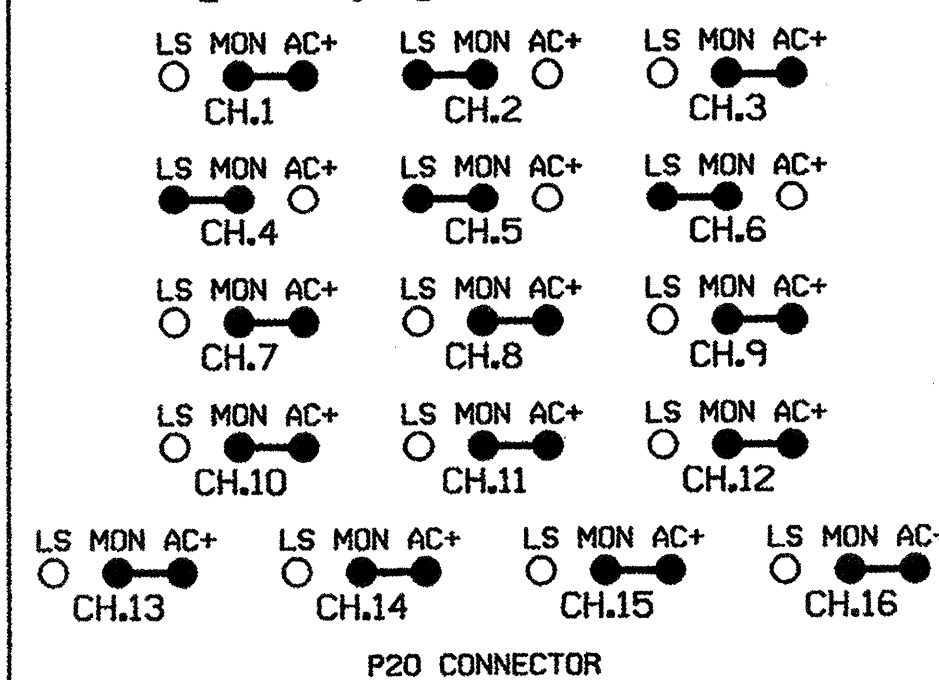

This pin clipped at the factory.

LOAD RESISTOR INSTALLATION DETAIL

VALUE (ohms)	WATTAGE
1.5K - 1.9K	25W (min)
2.0K - 3.0K	10W (min)

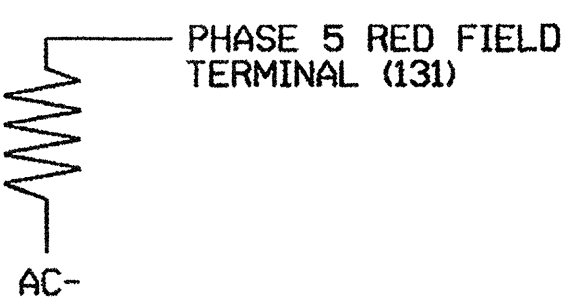

NOTE: The purpose of this resistor is to load the channel red monitor input in order for the Signal Sequence Monitor to use the full signal sequence monitoring capability on channels that do not use the red display in the field.

Signal Upgrade

ELECTRICAL AND PROGRAMMING DETAILS FOR:

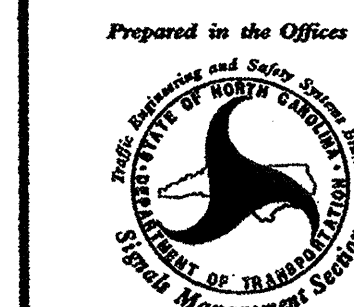

Prepared in the Office of:
 NC 112 (Sand Hill Road/Sardis Road) at SR3412 (Sand Hill Road)
 Division 13 Buncombe County South of Asheville
 PLAN DATE: February 2006 REVIEWED BY: T. Sapp
 PREPARED BY: Paul Marak REVIEWED BY:
 REVISIONS: INIT. DATE

SEAL
 GEORGE C. BROWN
 ENGINEER
 SEAL 022013
 SIGNATURE: George C. Brown 3/15/06
 DATE: 3/15/06
 SIG. INVENTORY NO. 13-0663