

CONTRACT: C201807 TIP PROJECT: B-4212

See Sheet 1-A For Index of Sheets

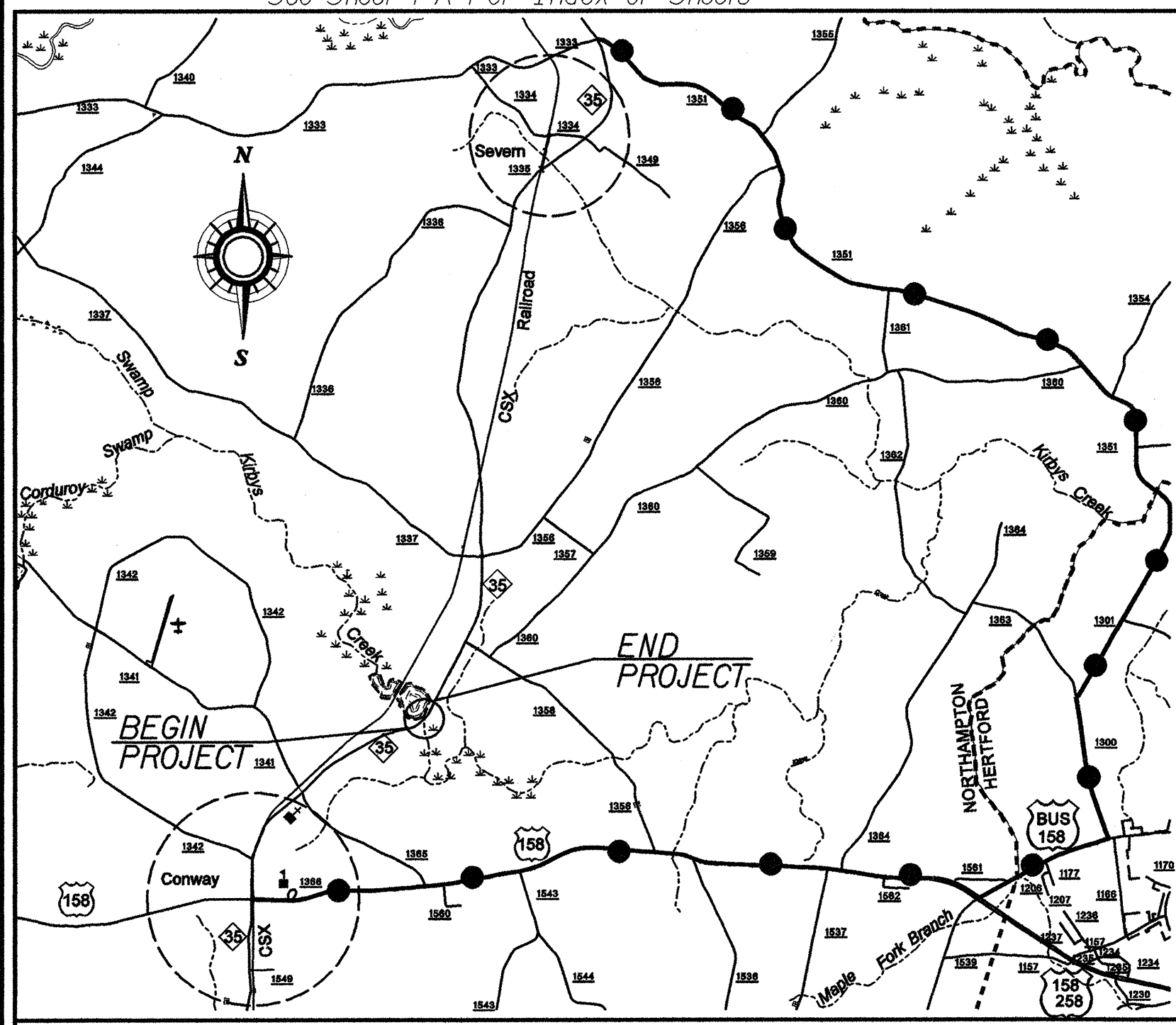

VICINITY MAP

LEGEND —●—●— Studied Detour Route

STATE OF NORTH CAROLINA
DIVISION OF HIGHWAYS

NORTHAMPTON COUNTY

LOCATION: BRIDGE NO. 77 OVER KIRBY'S CREEK ON NC 35

TYPE OF WORK: GRADING, DRAINAGE, PAVING AND STRUCTURE

STATE	STATE PROJECT REFERENCE NO.	SHEET NO.	TOTAL SHEETS
N.C.	B-4212	1	
STATE PROJ. NO.	F.A. PROJ. NO.	DESCRIPTION	
33558.1.1	BRSTP-35(1)	P.E.	
33558.2.1	BRSTP-35(1)	RW, UTIL.	
33558.3.1	BRSTP-35(1)	CONST.	

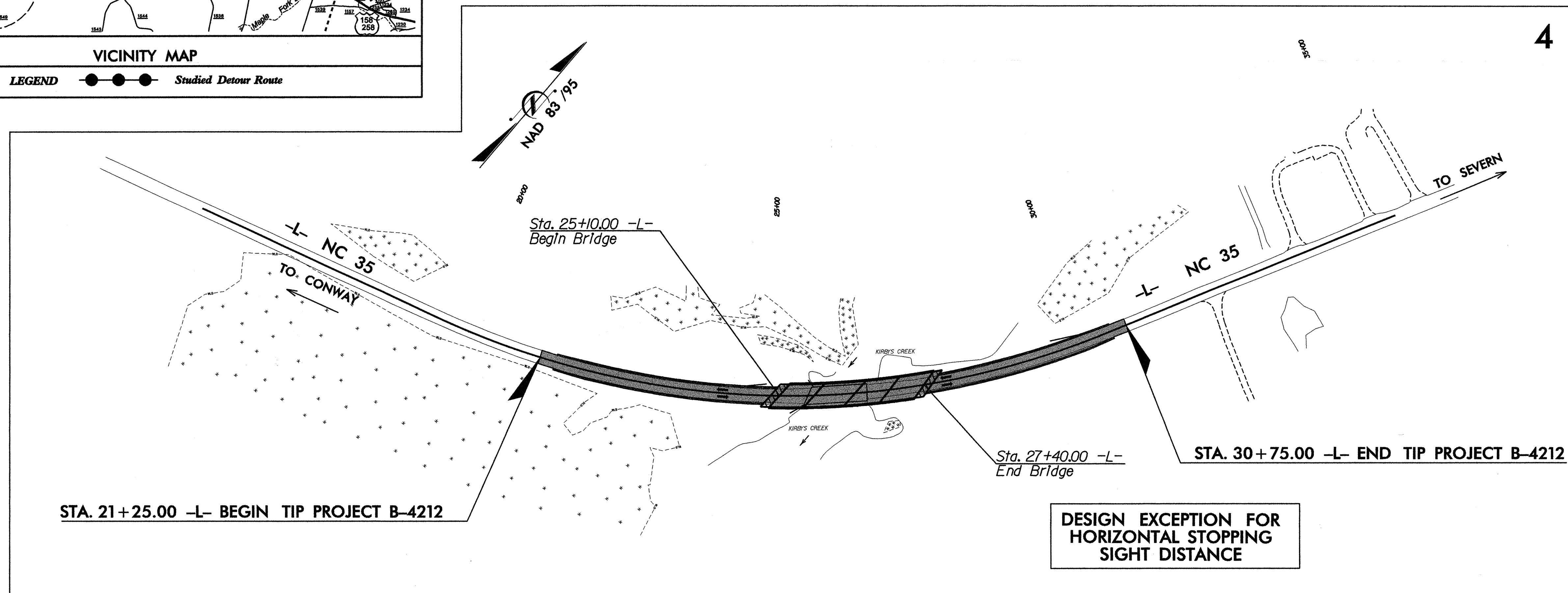

NCDOT CONTACT: CATHY HOUSER, P.E., PROJECT ENGINEER - ROADWAY DESIGN

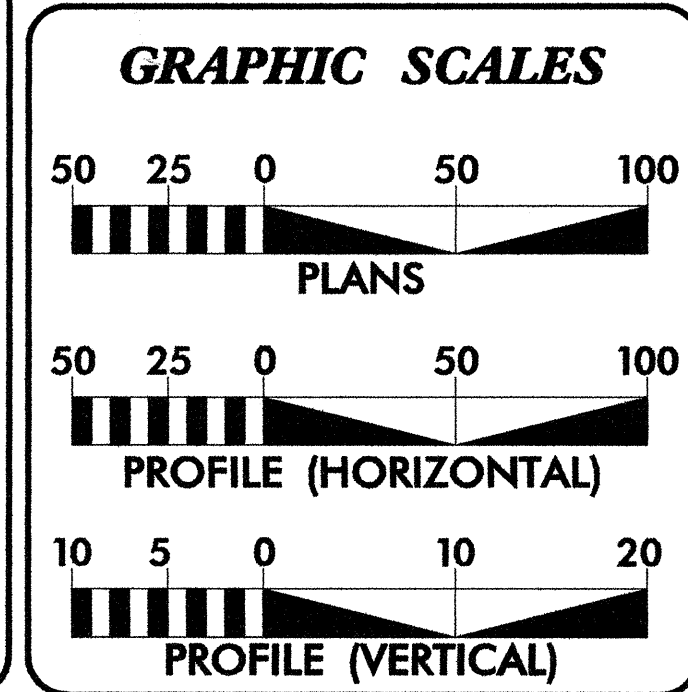

DESIGN DATA

ADT 2007 = 2700
ADT 2030 = 4500

DHV = 10 %
D = 60 %
T = 6 % *
V = 60 MPH

FUNC. CLASS =
RURAL MAJOR COLLECTOR

* TTST 2 % DUAL 4 %

PROJECT LENGTH

LENGTH ROADWAY TIP PROJECT B-4212 = 0.136 mi.
LENGTH STRUCTURE TIP PROJECT B-4212 = 0.044 mi.
TOTAL LENGTH TIP PROJECT B-4212 = 0.180 mi.

Prepared In the Office of:
WANG ENGINEERING COMPANY, INC.
CARY, N.C.
FOR NORTH CAROLINA DEPARTMENT OF TRANSPORTATION

2006 STANDARD SPECIFICATIONS

RIGHT OF WAY DATE:
MARCH 16, 2007

LETTING DATE:
MARCH 18, 2008

GREG S. PURVIS, P. E.
PROJECT ENGINEER

SCOTT L. KENNEDY
PROJECT DESIGN ENGINEER

HYDRAULICS ENGINEER
SUNGATE DESIGN GROUP, PA

12/05/07

WENDEY WELLS, P.E.

SIGNATURE: _____

ROADWAY DESIGN ENGINEER
WANG ENGINEERING

12/05/07

GREG S. PURVIS, P.E.

SIGNATURE: _____

DIVISION OF HIGHWAYS
STATE OF NORTH CAROLINA

Scott L. Kennedy, P.E.
STATE HIGHWAY DESIGN ENGINEER

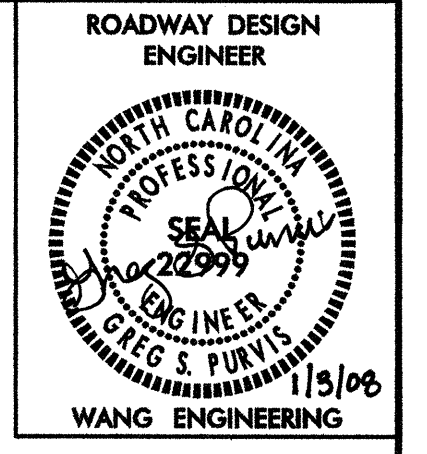

INDEX OF SHEETS	
SHEET NUMBER	SHEET
1	TITLE SHEET
1-A	INDEX OF SHEETS, GENERAL NOTES, AND LIST OF STANDARD DRAWINGS
1-B	CONVENTIONAL SYMBOLS
1-C	SURVEY CONTROL SHEET
2	TYPICAL SECTIONS AND PAVEMENT SCHEDULE
2-A	ROCK PLATING DETAIL
2-B	ANCHORAGE FOR FRAMES - BRICK/CONCRETE/PRECAST CONCRETE
3	SUMMARY OF QUANTITIES
3A	SUMMARY OF EARTHWORK SUMMARY OF GUARDRAIL, LIST OF PIPES, ENDWALLS, ETC., AND ASPHALT PAVEMENT REMOVAL SUMMARY
4	PLAN/PROFILE SHEET
TCP-1 THRU TCP-4	TRAFFIC CONTROL PLANS
EC-1 THRU EC-4	EROSION CONTROL PLANS
UC-1 THRU UC-4	UTILITY CONSTRUCTION PLANS
UD-1 THRU UD-2	UTILITY BY OTHERS PLANS
X-1	CROSS SECTION INDEX AND SUMMARY SHEET
X-2 THRU X-5	CROSS-SECTIONS
S-1 THRU S-45	STRUCTURE PLANS

2006 ROADWAY STANDARD DRAWINGS

The following Roadway Standards as appear in "Roadway Standard Drawings" Highway Design Branch - N. C. Department of Transportation - Raleigh, N. C., Dated July 18, 2006 are applicable to this project and by reference hereby are considered a part of these plans:

STD.NO.	TITLE
DIVISION 2 - EARTHWORK	
200.03	Method of Clearing - Method III
225.02	Guide for Grading Subgrade - Secondary and Local
225.04	Method of Obtaining Superelevation - Two Lane Pavement
DIVISION 3 - PIPE CULVERTS	
300.01	Method of Pipe Installation - Method 'A'
DIVISION 4 - MAJOR STRUCTURES	
422.10	Reinforced Bridge Approach Fills
DIVISION 5 - SUBGRADE, BASES AND SHOULDERS	
560.01	Method of Shoulder Construction - High Side of Superelevated Curve - Method I
DIVISION 8 - INCIDENTALS	
815.03	Pipe Underdrain and Blind Drain
840.00	Concrete Base Pad for Drainage Structures
840.29	Frames and Narrow Slot Flat Grates
840.35	Traffic Bearing Grated Drop Inlet
840.46	Traffic Bearing Precast Drainage Structure
846.01	Concrete Curb, Gutter and Curb & Gutter
846.04	Drop Inlet Installation in Shoulder Berm Gutter
862.01	Guardrail Placement
862.02	Guardrail Installation
862.03	Structure Anchor Units
862.04	Anchoring End of Guardrail - B-77 and B-83 Anchor Units

GENERAL NOTES:

2006 SPECIFICATIONS
EFFECTIVE: 07-18-06
REVISED: 07-18-06

GRADE LINE:
GRADING AND SURFACING:

THE GRADE LINES SHOWN DENOTE THE FINISHED ELEVATION OF THE PROPOSED SURFACING AT GRADE POINTS SHOWN ON THE TYPICAL SECTIONS. GRADE LINES MAY BE ADJUSTED AT THEIR BEGINNING AND ENDING AND AT STRUCTURES AS DIRECTED BY THE ENGINEER IN ORDER TO SECURE A PROPER TIE-IN.

CLEARING:

CLEARING ON THIS PROJECT SHALL BE PERFORMED TO THE LIMITS ESTABLISHED BY METHOD III.

SUPERELEVATION:

ALL CURVES ON THIS PROJECT SHALL BE SUPERELEVATED IN ACCORDANCE WITH STD. NO. 225.04 USING THE RATE OF SUPERELEVATION AND RUNOFF SHOWN ON THE PLANS. SUPERELEVATION IS TO BE REVOLVED ABOUT THE GRADE POINTS SHOWN ON THE TYPICAL SECTIONS.

SHOULDER CONSTRUCTION:

ASPHALT, EARTH, AND CONCRETE SHOULDER CONSTRUCTION ON THE HIGH SIDE OF SUPERELEVATED CURVES SHALL BE IN ACCORDANCE WITH STD. NO. 560.01.

UNDERDRAINS:

UNDERDRAINS SHALL BE CONSTRUCTED IN ACCORDANCE WITH STD. NO. 815.03 AT LOCATIONS DIRECTED BY THE ENGINEER.

GUARDRAIL:

THE GUARDRAIL LOCATIONS SHOWN ON THE PLANS MAY BE ADJUSTED DURING CONSTRUCTION AS DIRECTED BY THE ENGINEER. THE CONTRACTOR SHOULD CONSULT WITH THE ENGINEER PRIOR TO ORDERING GUARDRAIL MATERIAL.

TEMPORARY SHORING:

SHORING REQUIRED FOR THE MAINTENANCE OF TRAFFIC WILL BE PAID FOR AS "EXTRA WORK" IN ACCORDANCE WITH SECTION 104-7.

SUBSURFACE PLANS:

NO SUBSURFACE PLANS ARE AVAILABLE ON THIS PROJECT. THE CONTRACTOR SHOULD MAKE HIS OWN INVESTIGATION AS TO THE SUBSURFACE CONDITIONS.

END BENTS:

THE ENGINEER SHALL CHECK THE STRUCTURE END BENT PLANS, DETAILS, AND CROSS SECTION PRIOR TO SETTING OF THE SLOPE STAKES FOR THE EMBANKMENT OR EXCAVATION APPROACHING A BRIDGE.

UTILITIES:

UTILITY OWNERS ON THIS PROJECT ARE
Telephone - Embark
Electric - MEDIA COM DOMINION NC POWER
ANY RELOCATION OF EXISTING UTILITIES WILL BE ACCOMPLISHED BY OTHERS, EXCEPT AS SHOWN ON THE PLANS.

RIGHT-OF-WAY MARKERS:

ALL RIGHT-OF-WAY MARKERS ON THIS PROJECT SHALL BE PLACED BY OTHERS.









Note: Not to Scale

*S.U.E. = *Subsurface Utility Engineering*



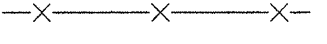
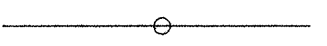
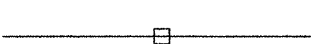



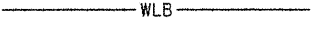
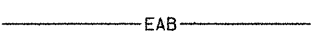

STATE OF NORTH CAROLINA
DIVISION OF HIGHWAYS

CONVENTIONAL PLAN SHEET SYMBOLS





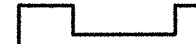

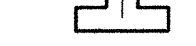
BOUNDARIES AND PROPERTY:

State Line	_____
County Line	_____
Township Line	_____
City Line	_____
Reservation Line	_____
Property Line	_____
Existing Iron Pin	_____ 
Property Corner	_____ 
Property Monument	_____ 
Parcel/Sequence Number	_____ 
Existing Fence Line	_____ 
Proposed Woven Wire Fence	_____ 
Proposed Chain Link Fence	_____ 
Proposed Barbed Wire Fence	_____ 
Existing Wetland Boundary	_____ 
Proposed Wetland Boundary	_____ 
Existing Endangered Animal Boundary	_____ 
Existing Endangered Plant Boundary	_____ 

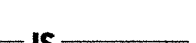
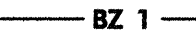
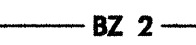

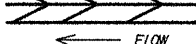

BUILDINGS AND OTHER CULTURE:

Gas Pump Vent or U/G Tank Cap	_____ 
Sign	_____ 
Well	_____ 
Small Mine	_____ 
Foundation	_____ 
Area Outline	_____ 
Cemetery	_____ 
Building	_____ 
School	_____ 
Church	_____ 
Dam	_____ 



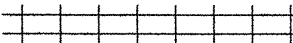

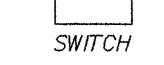







HYDROLOGY:

Stream or Body of Water	_____
Hydro, Pool or Reservoir	_____ 
Jurisdictional Stream	_____ 
Buffer Zone 1	_____ 
Buffer Zone 2	_____ 
Flow Arrow	_____ 
Disappearing Stream	_____ 
Spring	_____ 
Wetland	_____ 
Proposed Lateral, Tail, Head Ditch	_____ 
False Sump	_____ 









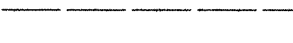

RAILROADS:

Standard Gauge	_____ 
RR Signal Milepost	_____ 
Switch	_____ 
RR Abandoned	_____ 
RR Dismantled	_____ 



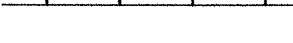
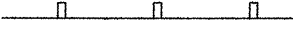
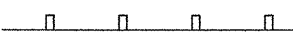

RIGHT OF WAY:

Baseline Control Point	_____ 
Existing Right of Way Marker	_____ 
Existing Right of Way Line	_____ 
Proposed Right of Way Line	_____ 
Proposed Right of Way Line with Iron Pin and Cap Marker	_____ 
Proposed Right of Way Line with Concrete or Granite Marker	_____ 
Existing Control of Access	_____ 
Proposed Control of Access	_____ 
Existing Easement Line	_____ 
Proposed Temporary Construction Easement	_____ 
Proposed Temporary Drainage Easement	_____ 
Proposed Permanent Drainage Easement	_____ 
Proposed Permanent Utility Easement	_____ 



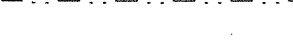

ROADS AND RELATED FEATURES:

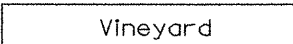
Existing Edge of Pavement	_____ 
Existing Curb	_____ 
Proposed Slope Stakes Cut	_____ 
Proposed Slope Stakes Fill	_____ 
Proposed Wheel Chair Ramp	_____ 
Proposed Wheel Chair Ramp Curb Cut	_____ 
Curb Cut for Future Wheel Chair Ramp	_____ 
Existing Metal Guardrail	_____ 
Proposed Guardrail	_____ 
Existing Cable Guiderail	_____ 
Proposed Cable Guiderail	_____ 
Equality Symbol	_____ 
Pavement Removal	_____ 



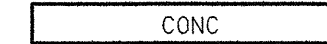
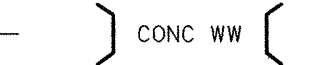
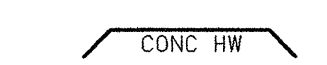

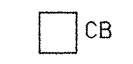
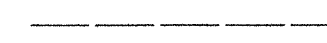

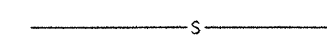



VEGETATION:

Single Tree	_____ 
Single Shrub	_____ 
Hedge	_____ 
Woods Line	_____ 
Orchard	_____ 
Vineyard	_____ 













EXISTING STRUCTURES:

MAJOR:	
Bridge, Tunnel or Box Culvert	_____ 
Bridge Wing Wall, Head Wall and End Wall	_____ 
MINOR:	
Head and End Wall	_____ 
Pipe Culvert	_____ 
Footbridge	_____ 
Drainage Box: Catch Basin, DI or JB	_____ 
Paved Ditch Gutter	_____ 
Storm Sewer Manhole	_____ 
Storm Sewer	_____ 



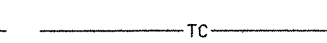
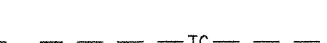

UTILITIES:

POWER:	
Existing Power Pole	_____ 
Proposed Power Pole	_____ 
Existing Joint Use Pole	_____ 
Proposed Joint Use Pole	_____ 
Power Manhole	_____ 
Power Line Tower	_____ 
Power Transformer	_____ 
U/G Power Cable Hand Hole	_____ 
H-Frame Pole	_____ 
Recorded U/G Power Line	_____ 
Designated U/G Power Line (S.U.E.*)	_____ 





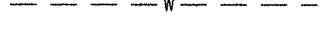
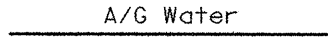

TELEPHONE:

Existing Telephone Pole	_____ 
Proposed Telephone Pole	_____ 
Telephone Manhole	_____ 
Telephone Booth	_____ 
Telephone Pedestal	_____ 
Telephone Cell Tower	_____ 
U/G Telephone Cable Hand Hole	_____ 
Recorded U/G Telephone Cable	_____ 
Designated U/G Telephone Cable (S.U.E.*)	_____ 
Recorded U/G Telephone Conduit	_____ 
Designated U/G Telephone Conduit (S.U.E.*)	_____ 
Recorded U/G Fiber Optics Cable	_____ 
Designated U/G Fiber Optics Cable (S.U.E.*)	_____ 

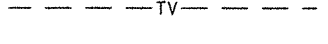

WATER:

Water Manhole	_____ 
Water Meter	_____ 
Water Valve	_____ 
Water Hydrant	_____ 
Recorded U/G Water Line	_____ 
Designated U/G Water Line (S.U.E.*)	_____ 
Above Ground Water Line	_____ 



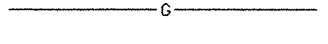
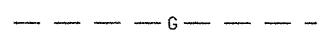
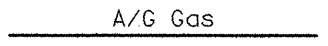

TV:

TV Satellite Dish	_____ 
TV Pedestal	_____ 
TV Tower	_____ 
U/G TV Cable Hand Hole	_____ 
Recorded U/G TV Cable	_____ 
Designated U/G TV Cable (S.U.E.*)	_____ 
Recorded U/G Fiber Optic Cable	_____ 
Designated U/G Fiber Optic Cable (S.U.E.*)	_____ 





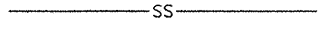
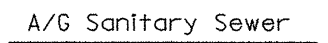
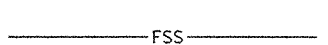





GAS:

Gas Valve	_____ 
Gas Meter	_____ 
Recorded U/G Gas Line	_____ 
Designated U/G Gas Line (S.U.E.*)	_____ 
Above Ground Gas Line	_____ 

SANITARY SEWER:

Sanitary Sewer Manhole	_____ 
Sanitary Sewer Cleanout	_____ 
U/G Sanitary Sewer Line	_____ 
Above Ground Sanitary Sewer	_____ 
Recorded SS Forced Main Line	_____ 
Designated SS Forced Main Line (S.U.E.*)	_____ 

MISCELLANEOUS:

Utility Pole	_____ 
Utility Pole with Base	_____ 
Utility Located Object	_____ 
Utility Traffic Signal Box	_____ 
Utility Unknown U/G Line	_____ 
U/G Tank; Water, Gas, Oil	_____ 
AG Tank; Water, Gas, Oil	_____ 
U/G Test Hole (S.U.E.*)	_____ 
Abandoned According to Utility Records	_____ 
End of Information	_____ 

SURVEY CONTROL SHEET B-4212

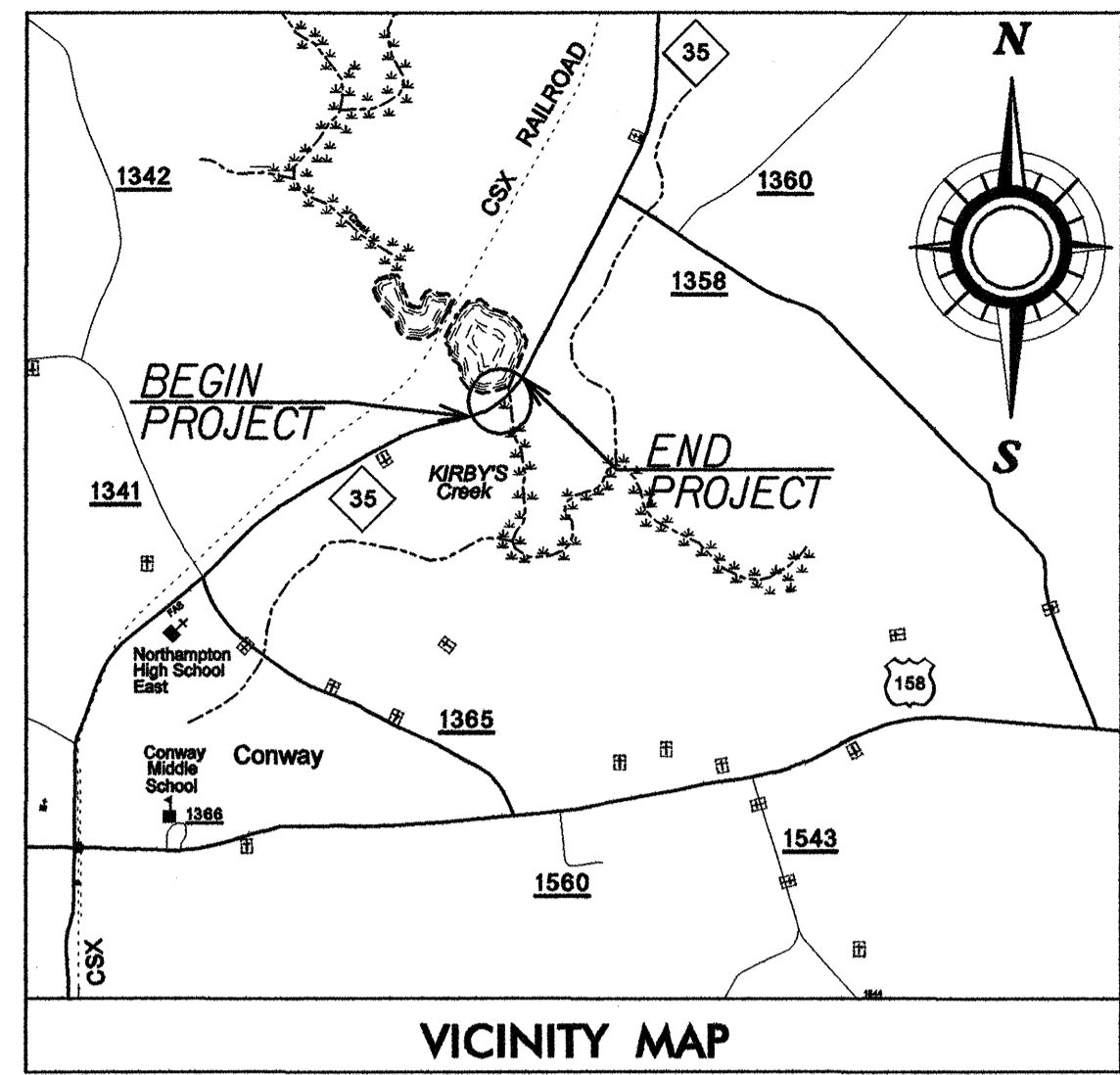

CONTROL DATA

BL	POINT	DESC.	NORTH	EAST	ELEVATION	L STATION	OFFSET
BL5		(BL-5)	988759.9430	2526090.7180	69.00	11+09.72	15.74 RT
BL4		(BL-4)	989005.9960	2526963.3790	49.22	20+16.27	23.38 RT
BL3		(BL-3)	989420.3020	2527562.8770	48.90	27+42.88	17.94 RT
BL1		(GPS B4212-1)	990343.1110	2528074.3010	48.26	37+95.92	16.22 RT
BL2		(GPS B4212-2)	991524.9000	2528687.2300	56.15	OUTSIDE PROJECT LIMITS	

BENCHMARK DATA

 BM10 ELEVATION = 44.94
 N 989167 E 2527052
 BL STATION 15+71 82 LEFT
 R/R SPIKE IN BASE OF 16 IN. GUM

 BM11 ELEVATION = 48.48
 N 989637 E 2527652
 BL STATION 23+68 27 LEFT
 R/R SPIKE IN BASE OF 30 IN. GUM

NCDOT BASELINE STATION "BL-5"
 LOCALIZED PROJECT COORDINATES
 N = 988,759.9430
 E = 2,526,090.7180

STA. 21+25.00 -L- BEGIN TIP PROJECT B-4212
 LOCALIZED PROJECT COORDINATES
 N = 989,066.8537
 E = 2,527,057.5450

STA. 30+75.00 -L- END TIP PROJECT B-4212
 LOCALIZED PROJECT COORDINATES
 N = 989,709.9419
 E = 2,527,729.2031

NCDOT GPS STATION "B4212-2"
 LOCALIZED PROJECT COORDINATES
 N = 991,524.9000
 E = 2,528,687.2300

NCDOT GPS STATION "B4212-1"
 LOCALIZED PROJECT COORDINATES
 N = 990,343.1110
 E = 2,528,074.3010

NCDOT BASELINE STATION "BL-4"
 LOCALIZED PROJECT COORDINATES
 N = 989,005.9960
 E = 2,526,963.3790

NCDOT BASELINE STATION "BL-3"
 LOCALIZED PROJECT COORDINATES
 N = 989,420.3020
 E = 2,527,562.8770

DATUM DESCRIPTION
 THE LOCALIZED COORDINATE SYSTEM DEVELOPED FOR THIS PROJECT IS BASED ON THE STATE PLANE COORDINATES ESTABLISHED BY NCDOT FOR MONUMENT "B4212-1" WITH NAD 1983/95 STATE PLANE GRID COORDINATES OF NORTHING: 990343.111(ft) EASTING: 2528074.301(ft) THE AVERAGE COMBINED GRID FACTOR USED ON THIS PROJECT (GROUND TO GRID) IS: 1.00009626 THE N.C. LAMBERT GRID BEARING AND LOCALIZED HORIZONTAL GROUND DISTANCE FROM "BL-4" TO -L- STATION 21+25.00 IS N 57° 07' 34.31" E 112.12 ALL LINEAR DIMENSIONS ARE LOCALIZED HORIZONTAL DISTANCES THE VERTICAL DATUM IS BASED ON NCGS NOR 56 1998 (ELEV.46.03'). VERTICAL DATUM USED IS NAVD 88

NOTES:

- THE CONTROL DATA FOR THIS PROJECT CAN BE FOUND ELECTRONICALLY BY SELECTING [HTTP://WWW.DOH.DOT.STATE.NC.US/PRECONSTRUCT/HIGHWAY/LOCATION/PROJECT](http://www.doh.dot.state.nc.us/preconstruct/highway/location/project)
- FILE: b4212_ls_control_060621.txt
- SITE CALIBRATION PARAMETERS HAVE NOT BEEN DETERMINED FOR THIS PROJECT.
- IF FURTHER INFORMATION IS NEEDED, PLEASE CONTACT THE LOCATION AND SURVEYS UNIT.
- INDICATES GEODETIC CONTROL MONUMENTS USED OR SET FOR HORIZONTAL PROJECT CONTROL BY THE NCDOT LOCATION AND SURVEYS UNIT.
- PROJECT CONTROL ESTABLISHED UTILIZING GLOBAL POSITIONING SYSTEM.
- NETWORK FOR GPS "B4212-1" ESTABLISHED FROM NGS ONLINE POSITIONING USER SERVICE (OPUS)

NOTE: DRAWING NOT TO SCALE

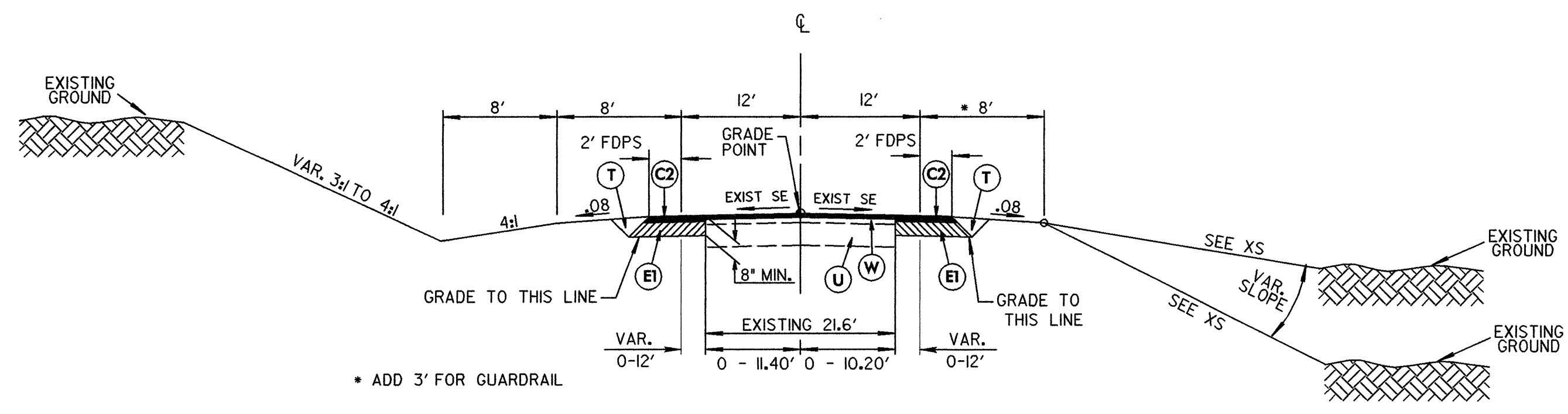

TRANSITION FROM EXIST. TO T.S. NO. 1
 -L- Sta. 21+50.00 to Sta. 21+50.00

TYPICAL SECTION NO. 1 AS FOLLOWS
 -L- Sta. 21+50.00 to Sta. 23+10.00
 -L- Sta. 29+40.00 to Sta. 30+50.00

TRANSITION FROM T.S. NO. 1 TO EXIST.
 -L- Sta. 30+50.00 to Sta. 30+75.00

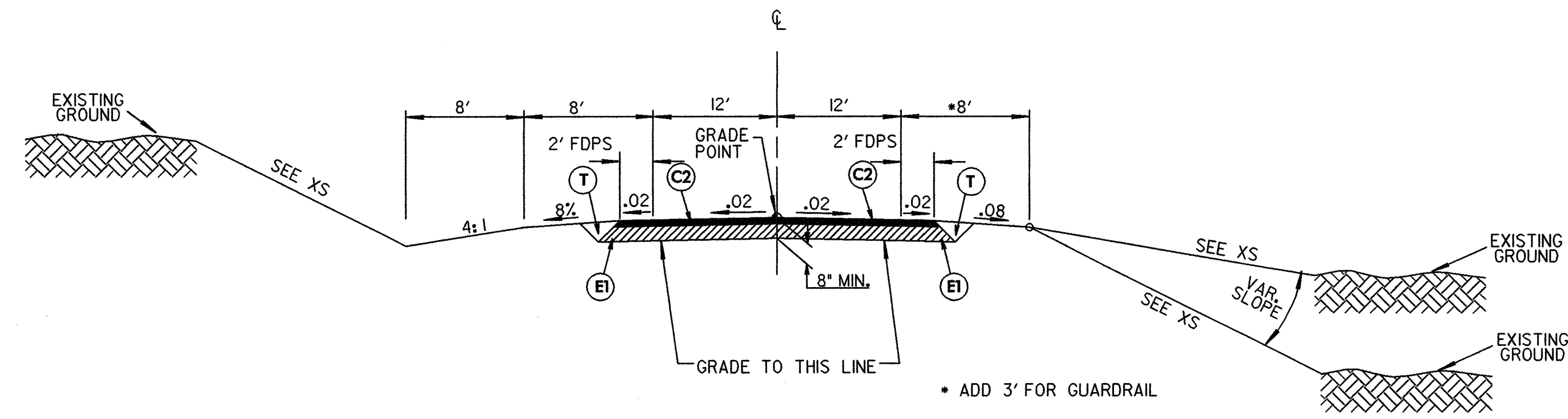

TYPICAL SECTION NO. 2
 USE TYPICAL SECTION NO. 2 AS FOLLOWS
 -L- Sta. 23+10.00 to Begin Bridge Sta. 25+10.00
 -L- End Bridge Sta. 27+40.00 to Sta. 29+40.00

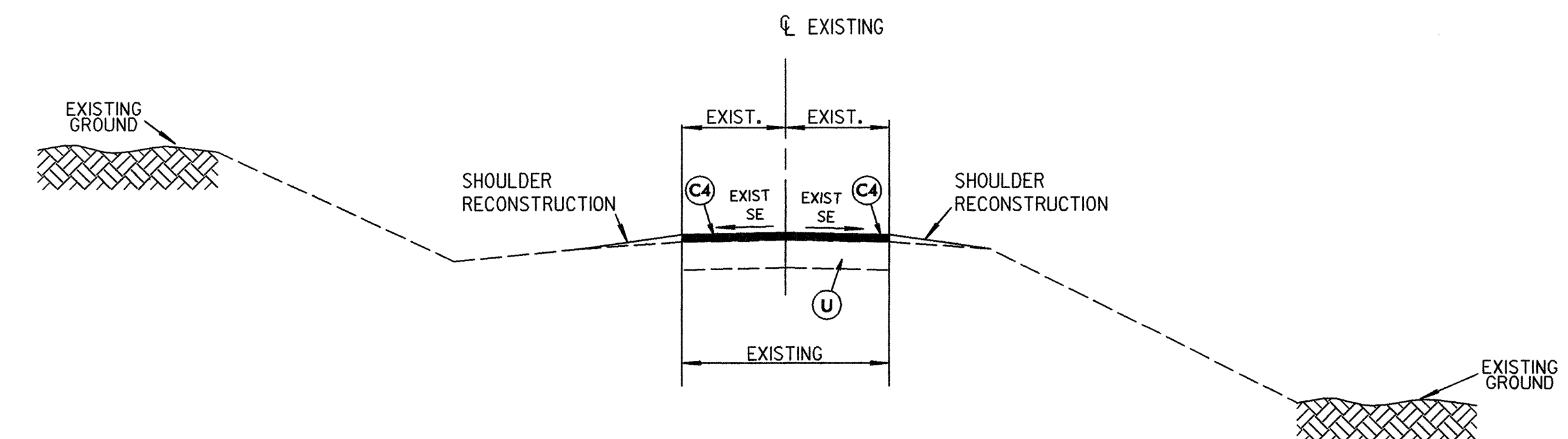

TYPICAL SECTION NO. 3 -DETOUR-
 USE TYPICAL SECTION NO. 3 AS FOLLOWS
 -SR 1300- RESURFACE EXISTING PAVEMENT

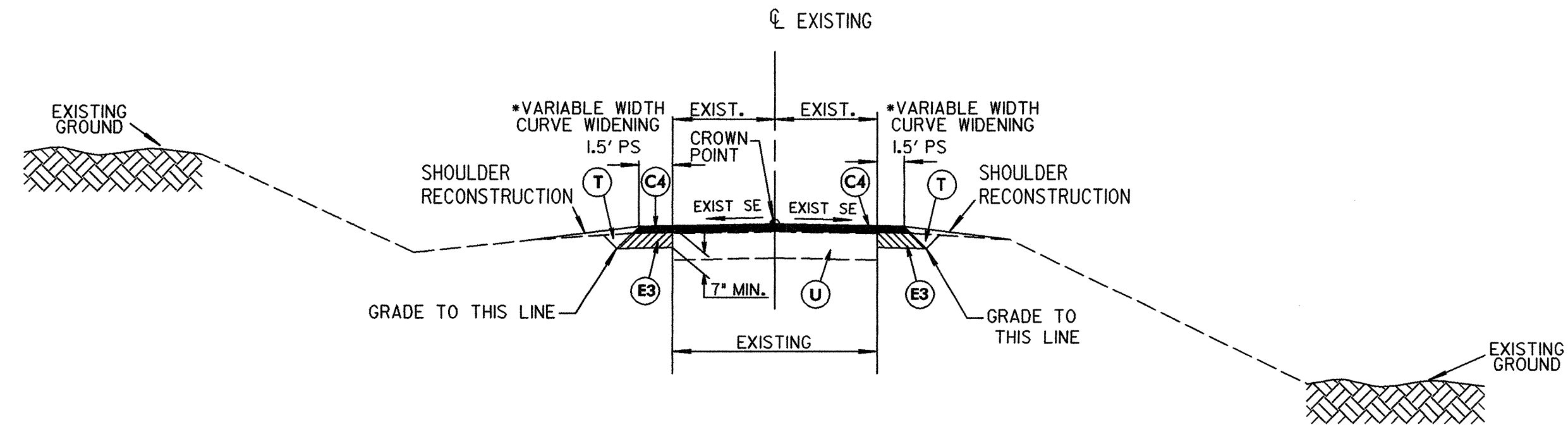

TYPICAL SECTION NO. 4 -DETOUR-
 USE TYPICAL SECTION NO. 4 AS FOLLOWS
 * -SR 1301- SELECT CURVE WIDENING AND RESURFACE EXISTING PAVEMENT
 -SR 1351- WIDEN 1.5 FT AND RESURFACE EXISTING PAVEMENT

C1	PROP. APPROX. 1.5" ASPHALT CONC. SURFACE COURSE, TYPE S9.5B, AT AN AVERAGE RATE OF 168 LBS PER SQ. YD.
C2	PROP. APPROX. 3" ASPHALT CONC. SURFACE COURSE, TYPE S9.5B, AT AN AVERAGE RATE OF 168 LBS PER SQ. YD. IN EACH OF TWO LAYERS.
C3	PROP. VAR. DEPTH ASPHALT CONC. SURFACE COURSE, TYPE S9.5B, AT AN AVERAGE RATE OF 112 LBS PER SQ. YD. PER 1" DEPTH TO BE PLACED IN LAYERS NOT LESS THAN 1.5" OR GREATER THAN 2" IN DEPTH.
C4	PROP. APPROX. 1.5" ASPHALT CONC. SURFACE COURSE, TYPE SF9.5A, AT AN AVERAGE RATE OF 165 LBS PER SQ. YD.
E1	PROP. APPROX. 5" ASPHALT CONC. BASE COURSE, TYPE B25.0B, AT AN AVERAGE RATE OF 570 LBS PER SQ. YD.
E2	PROP. VAR. DEPTH ASPHALT CONC. BASE COURSE, TYPE B25.0B, AT AN AVERAGE RATE OF 114 LBS PER SQ. YD. PER 1" DEPTH TO BE PLACED IN LAYERS NOT LESS THAN 3" OR GREATER THAN 5.5" IN DEPTH.
E3	PROP. APPROX. 5.5" ASPHALT CONC. BASE COURSE, TYPE B25.0B, AT AN AVERAGE RATE OF 627 LBS PER SQ. YD.
T	EARTH MATERIAL
U	EXISTING PAVEMENT
W	VARIABLE DEPTH PAVEMENT (SEE WEDGING DETAILS)

NOTE: ALL SLOPES 1:1 UNLESS OTHERWISE SPECIFIED 3" MIN.

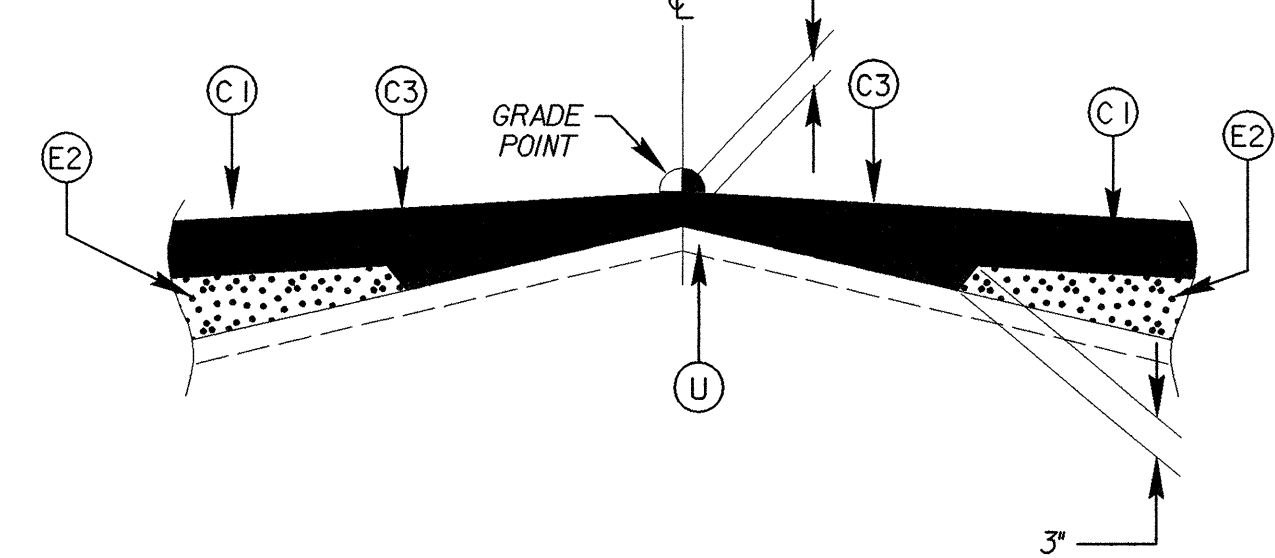

DETAIL SHOWING METHOD OF WEDGING

PREFORMED SCOUR HOLE W/ LEVEL SPREADER APRON

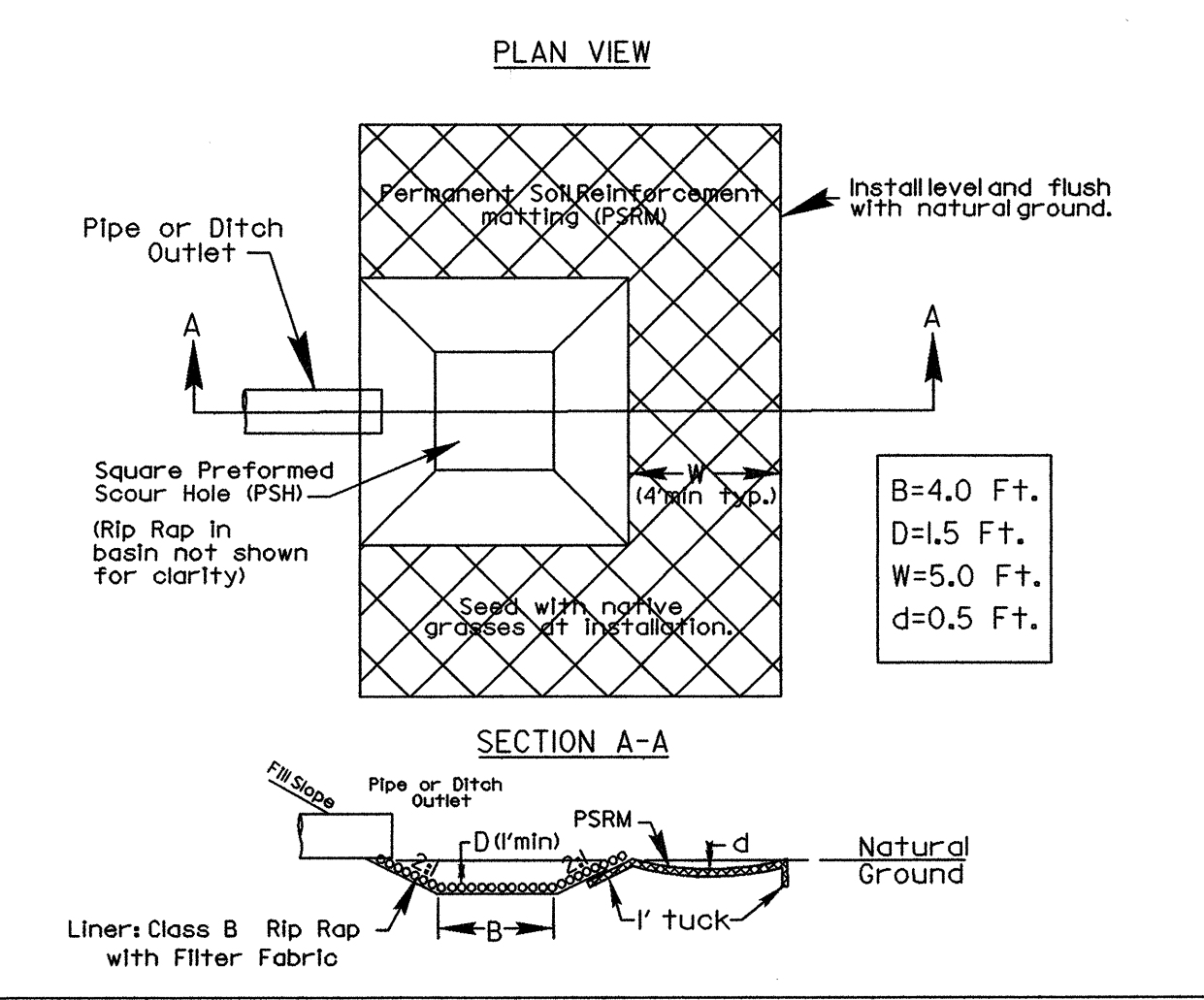

STA 24+92 -L- LT
 STA 29+50 -L- LT
 CL 'B' RIP RAP=90 TONS EACH
 DDE EST 15 CY EACH
 FF EST 13 SY EACH
 PSRM EST 25 SY EACH

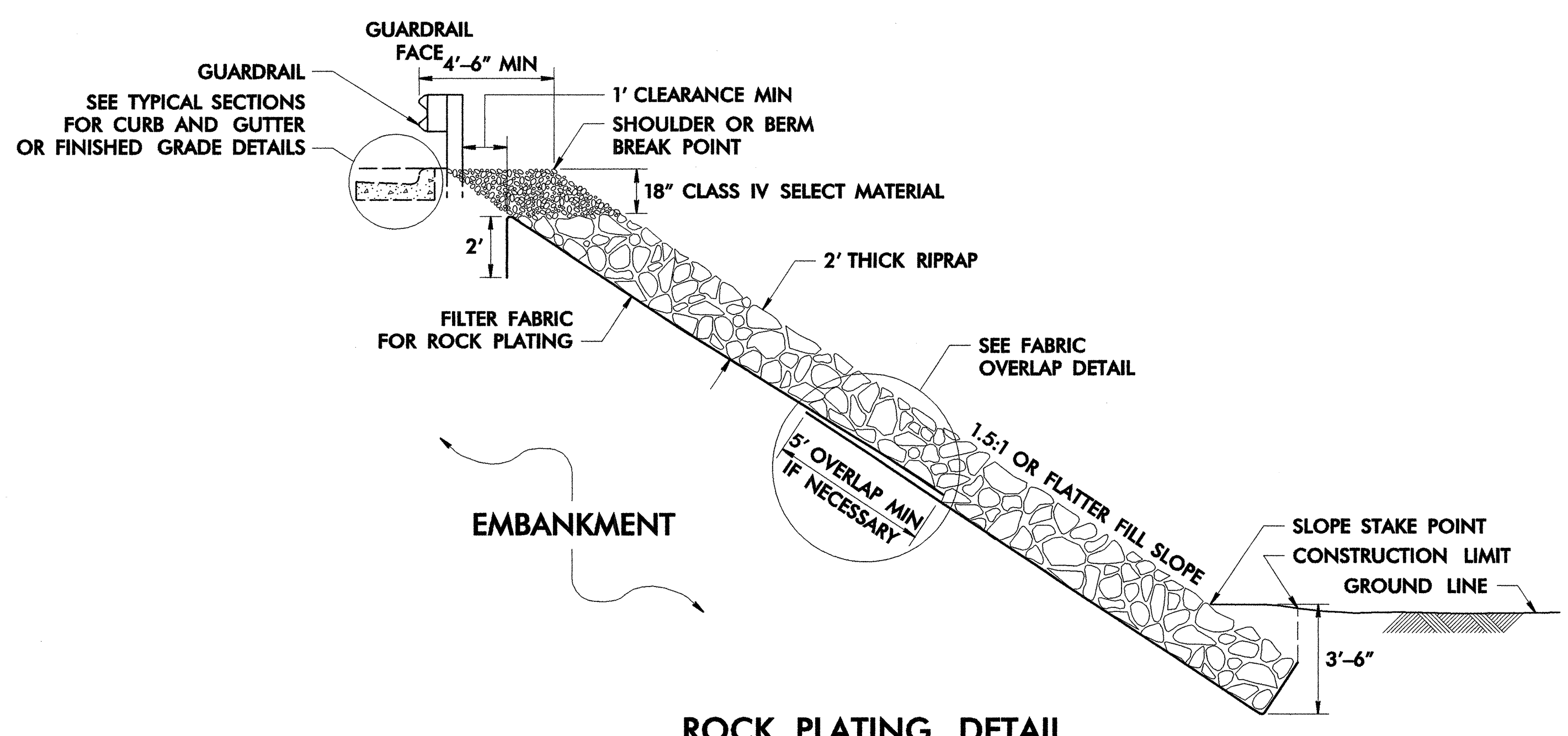

ROCK PLATING DETAIL

USE ROCK PLATING DETAIL
 AT THE FOLLOWING LOCATIONS:
 STA 27+65 TO STA 29+40
 EXTEND ROCK PLATING LIMITS TO 2:1 SLOPES.

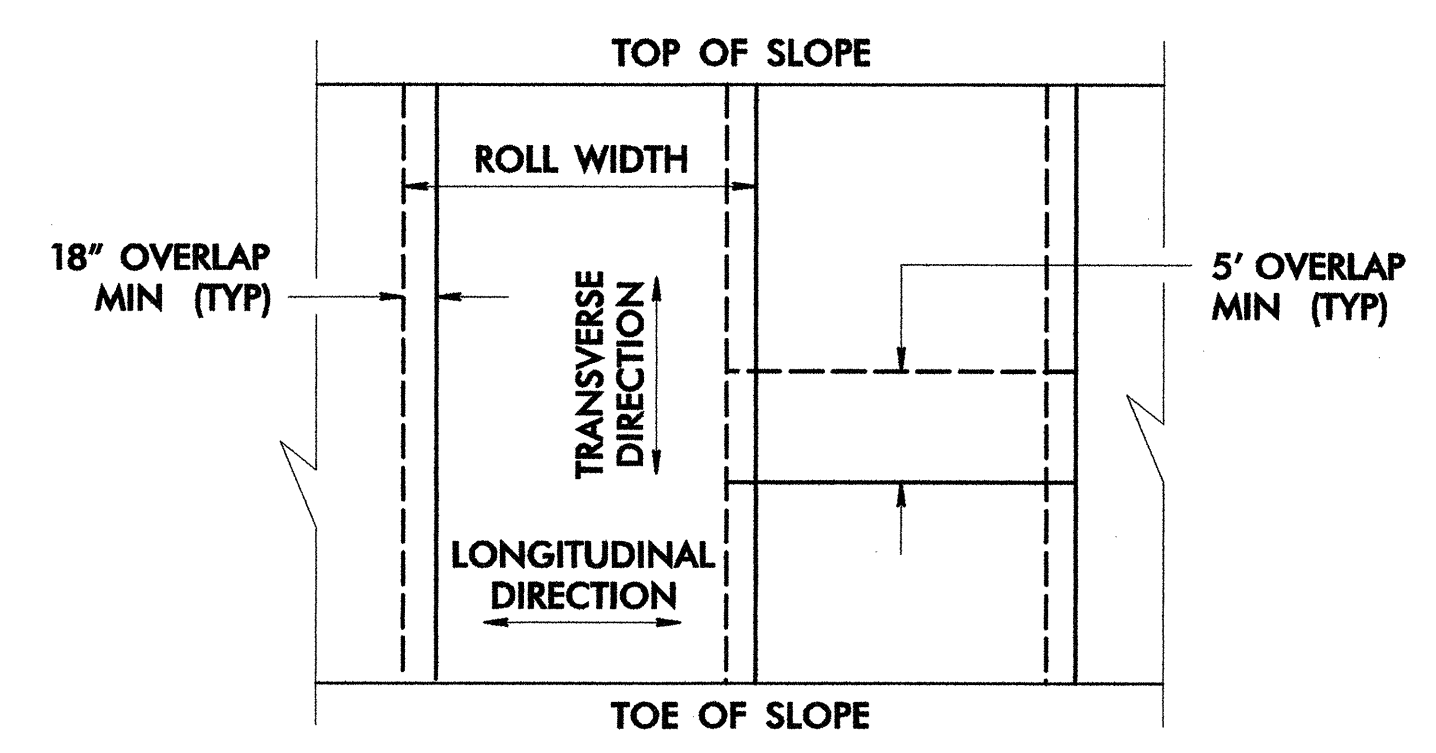

**FABRIC OVERLAP DETAIL
 (PLAN VIEW)**

ESTIMATED QUANTITIES:	
ROCK PLATING -----	273 SQ. YD.

FOR ROCK PLATING,
 SEE ROCK PLATING SPECIAL PROVISION.

STATE OF NORTH CAROLINA
DEPT. OF TRANSPORTATION
DIVISION OF HIGHWAYS
RALEIGH, N.C.

ENGLISH DETAIL DRAWING FOR
ANCHORAGE FOR FRAMES
BRICK/CONCRETE/PRECAST CONCRETE

SHEET 1 OF 1
840D25

STATE OF NORTH CAROLINA
DEPT. OF TRANSPORTATION
DIVISION OF HIGHWAYS
RALEIGH, N.C.

ENGLISH DETAIL DRAWING FOR
ANCHORAGE FOR FRAMES
BRICK/CONCRETE/PRECAST CONCRETE

SHEET 1 OF 1
840D25

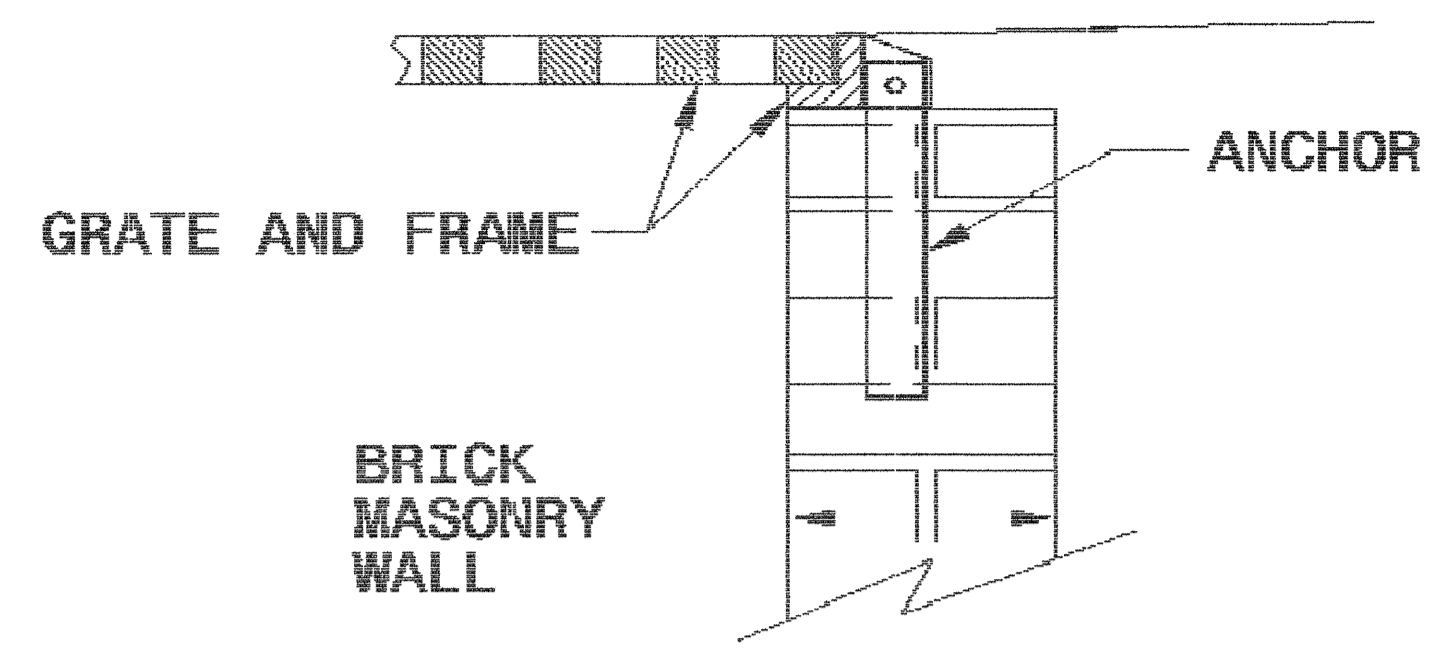

BRICK MASONRY CONSTRUCTION

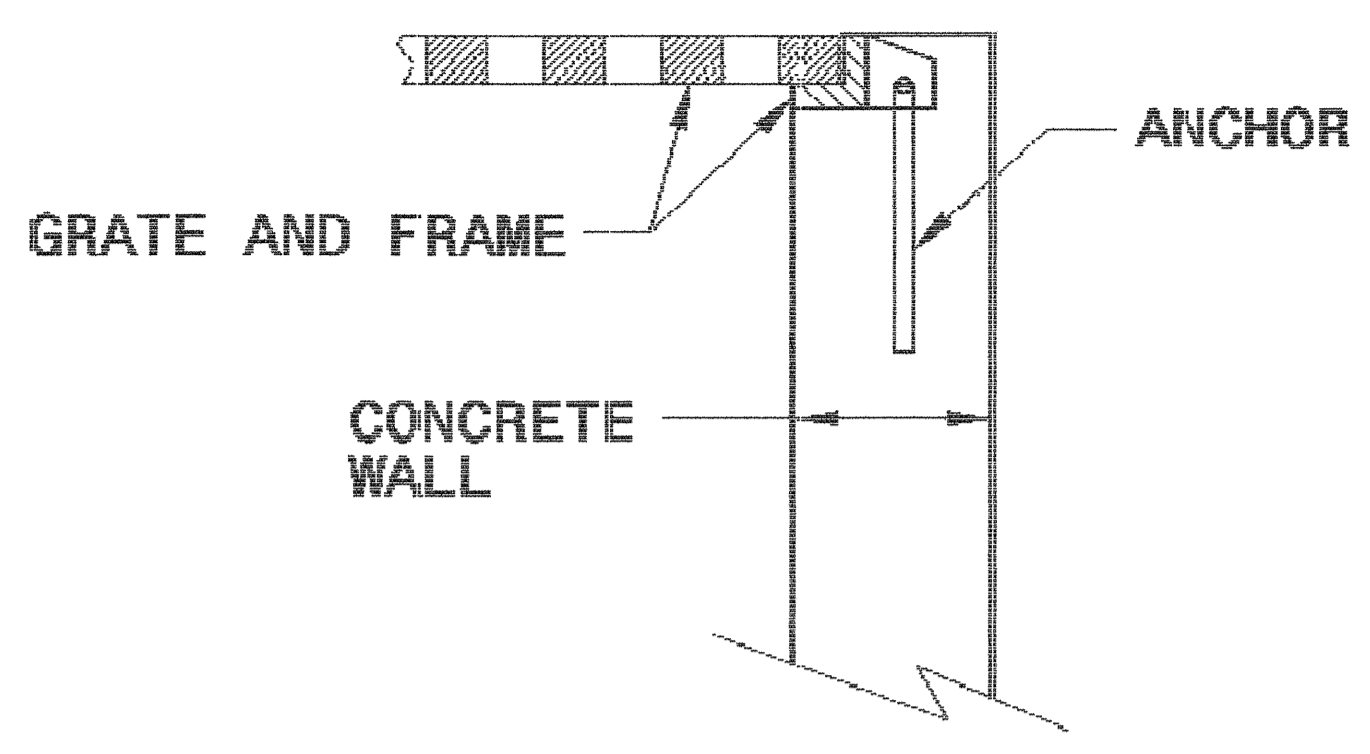

CONCRETE CONSTRUCTION

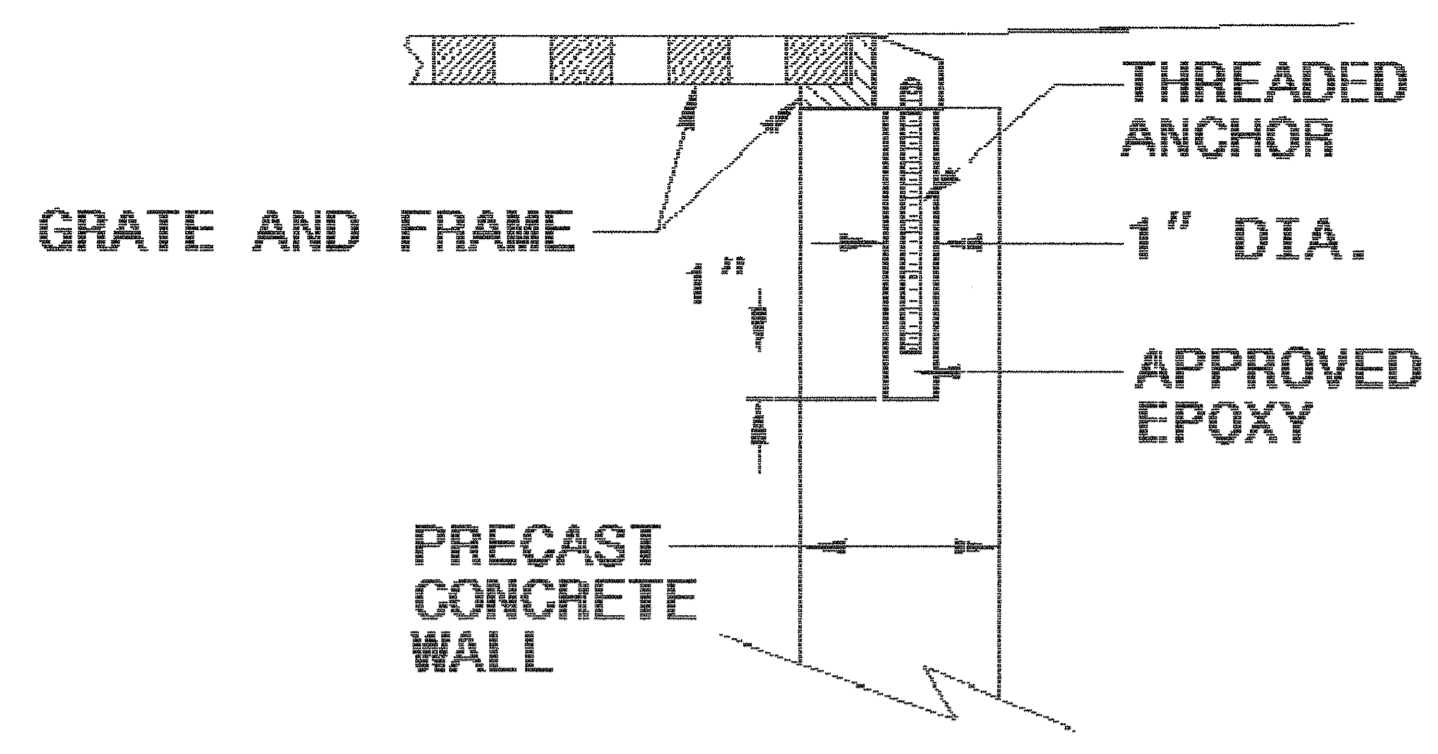

PRECAST CONCRETE CONSTRUCTION

DETAIL SHOWING ANCHORAGE OF FRAME FOR GRATED DROP INLET

NOTE:
CONSTRUCT GRATED DROP INLET TO COINCIDE WITH NORMAL OR SUPERELEVATED SHOULDER OR PAVEMENT SLOPE.

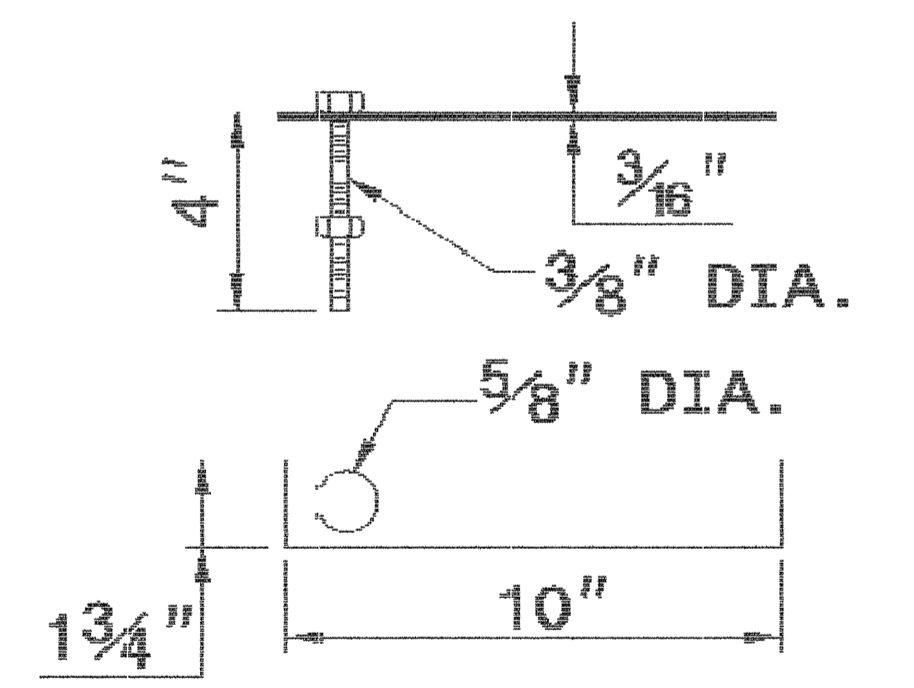

MASONRY ANCHOR
3/8" DIA. BOLT WITH PLATE

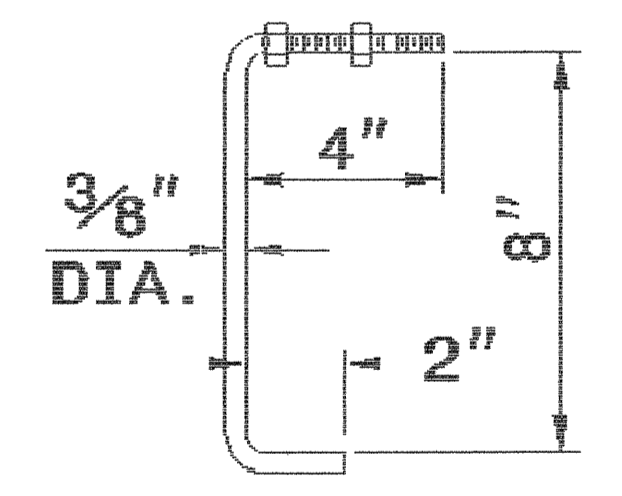

CONCRETE ANCHOR
3/8" DIA. BENT BAR

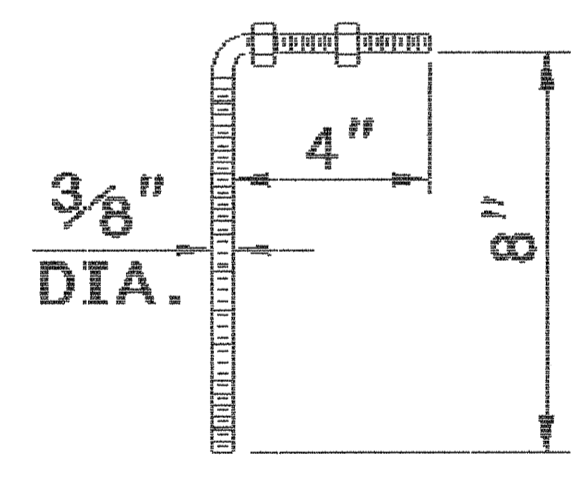

PRECAST CONCRETE ANCHOR
3/8" DIA. BENT BAR

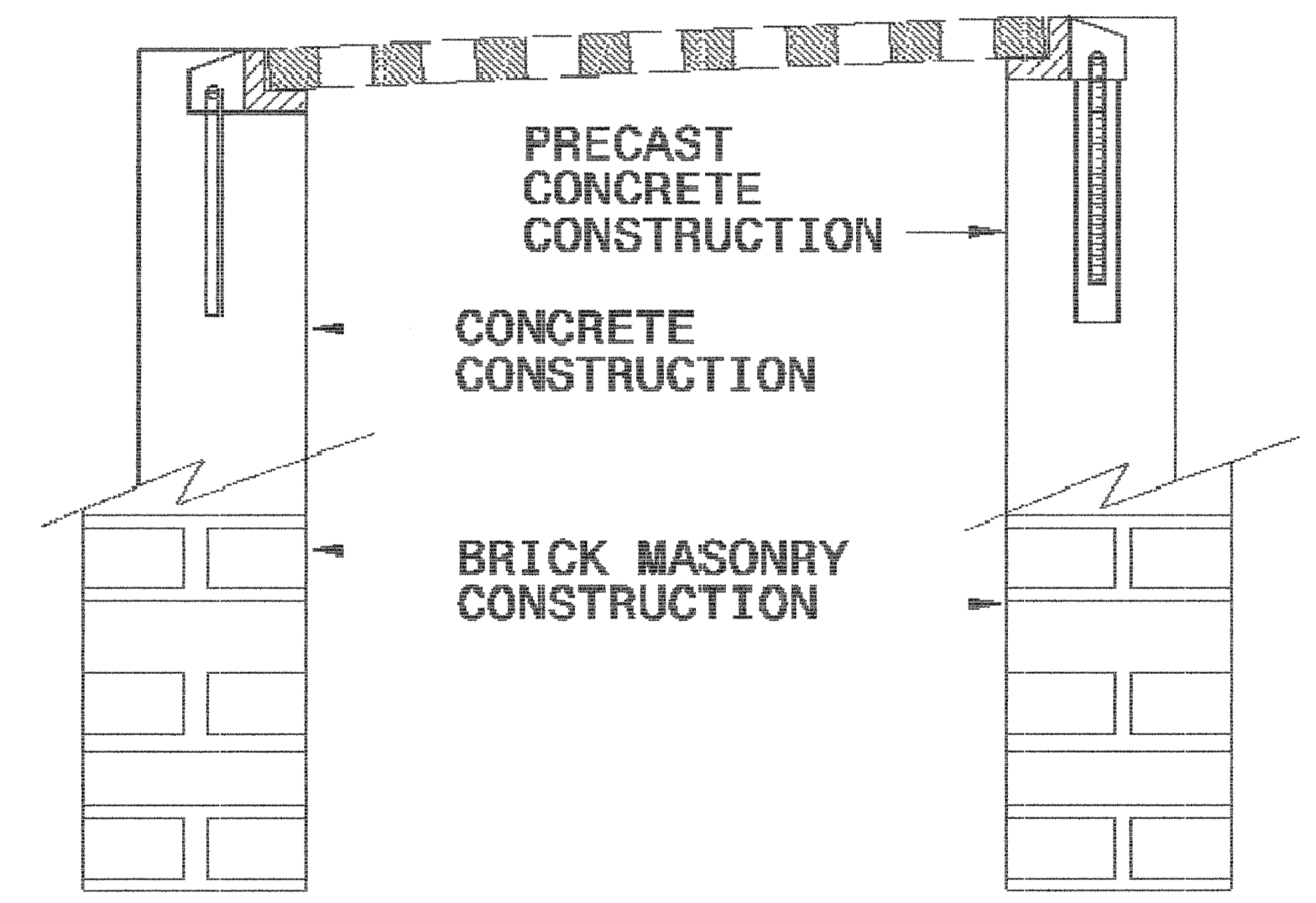

FRAME AND GRATE INSTALLATION FOR NORMAL CROWN AND SUPERELEVATED SECTIONS

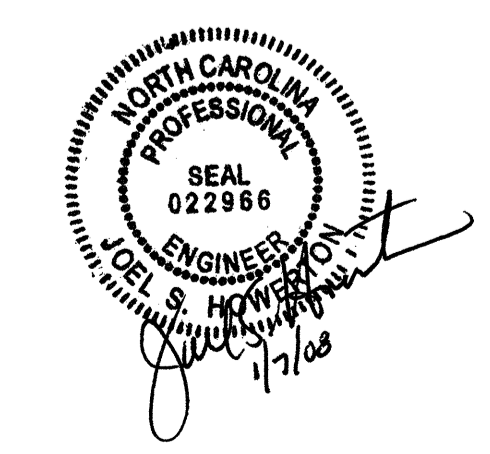

**PROJECT SERVICES UNIT
STANDARDS AND SPECIAL DESIGN**
Office 919-250-4128 FAX 919-250-4119

SEE PLATE FOR TITLE

ORIGINAL BY: 2006 STD 840.25	DATE: 07/18/06
MODIFIED BY: E.E. WARD	DATE: 9/25/06
CHECKED BY:	DATE:
FILE SPEC.:	

I:\Projects\2006\840D25\Social Data\15\15-10-06\stds\840D25 Anchor-plate for Frames\840D25.dgn

I:\Projects\2006\840D25\Social Data\15\15-10-06\stds\840D25 Anchor-plate for Frames\840D25.dgn 12/05/2007 05:31:17 AM

STATE OF NORTH CAROLINA
DIVISION OF HIGHWAYS
SUMMARY OF QUANTITIES

5/28/99

STATE OF NORTH CAROLINA DIVISION OF HIGHWAYS ROADWAY SUMMARY OF QUANTITIES FOR CONTRACT - C201807														
ItemNumber	Sec #	Quantity	Unit	Description	ItemNumber	Sec #	Quantity	Unit	Description	ItemNumber	Sec #	Quantity	Unit	Description
000100000-N	800	Lump Sum		MOBILIZATION	228600000-N	840	2	EA	MASONRY DRAINAGE STRUCTURES	587120000-E	1550	340	LF	TRENCHLESS INSTALLATION OF 3" IN SOIL
002900000-N	SP	Lump Sum		REINFORCED BRIDGE APPROACH FILL, STATION ***** (26+25.000)	236700000-N	840	2	EA	FRAME WITH TWO GRATES, STD 840.29	587121000-E	1550	340	LF	TRENCHLESS INSTALLATION OF 3" NOT IN SOIL
005000000-E	226	1	ACR	SUPPLEMENTARY CLEARING & GRUB-BING	253100000-E	SP	273	SY	GENERIC GRADING ITEM (SY) ROCK PLATING	587150000-E	1550	375	LF	TRENCHLESS INSTALLATION OF 8" IN SOIL
005700000-E	226	250	CY	UNDERCUT EXCAVATION	255600000-E	846	204	LF	SHOULDER BERM GUTTER	587151000-E	1550	375	LF	TRENCHLESS INSTALLATION OF 8" NOT IN SOIL
006300000-N	SP	Lump Sum		GRADING	303000000-E	862	600	LF	STEEL BM GUARDRAIL	600000000-E	1605	550	LF	TEMPORARY SILT FENCE
010600000-E	230	3,300	CY	BORROW EXCAVATION	315000000-N	862	5	EA	ADDITIONAL GUARDRAIL POSTS	600600000-E	1610	75	TON	STONE FOR EROSION CONTROL, CLASS A
019500000-E	265	1,900	CY	SELECT GRANULAR MATERIAL	327000000-N	SP	4	EA	GUARDRAIL ANCHOR UNITS, TYPE 350	600900000-E	1610	55	TON	STONE FOR EROSION CONTROL, CLASS B
019600000-E	270	1,900	SY	FABRIC FOR SOIL STABILIZATION	331700000-N	862	4	EA	GUARDRAIL ANCHOR UNITS, TYPE B-77	601200000-E	1610	55	TON	SEDIMENT CONTROL STONE
031800000-E	300	5	TON	FOUNDATION CONDITIONING MATERIAL, MINOR STRS	336000000-E	863	343	LF	REMOVE EXISTING GUARDRAIL	601500000-E	1615	1.5	ACR	TEMPORARY MULCHING
036600000-E	310	12	LF	15" RC PIPE CULVERTS, CLASS III	364200000-E	876	25	TON	RIP RAP, CLASS A	601800000-E	1620	50	LB	SEED FOR TEMPORARY SEEDING
070800000-E	310	28	LF	15" BIT COAT CS PIPE CULVERTS, TYPE B 0.064" THICK	365600000-E	876	150	SY	FILTER FABRIC FOR DRAINAGE	602100000-E	1620	0.25	TON	FERTILIZER FOR TEMPORARY SEEDING
080600000-E	310	2	EA	15" BIT COAT CS PIPE ELBOWS, TYPE B 0.064" THICK	365900000-N	SP	2	EA	PREFORMED SCOUR HOLES WITH LEVEL SPREADER APRON	602400000-E	1622	150	LF	TEMPORARY SLOPE DRAINS
122000000-E	545	300	TON	INCIDENTAL STONE BASE	440000000-E	1110	276	SF	WORK ZONE SIGNS (STATIONARY)	602700000-N	1622	3	EA	INLET PROTECTION AT TEMPORARY SLOPE DRAINS
124500000-E	SP	16.6	SMI	SHOULDER RECONSTRUCTION	440500000-E	1110	112	SF	WORK ZONE SIGNS (PORTABLE)	602900000-E	SP	225	LF	SAFETY FENCE
148900000-E	610	5,085	TON	ASPHALT CONC BASE COURSE, TYPE B25.0B	441000000-E	1110	51	SF	WORK ZONE SIGNS (BARRICADE MOUNTED)	603000000-E	1630	60	CY	SILT EXCAVATION
151900000-E	610	348	TON	ASPHALT CONC SURFACE COURSE, TYPE S9.5B	442000000-N	1120	2	EA	CHANGEABLE MESSAGE SIGN	603600000-E	1631	200	SY	MATting FOR EROSION CONTROL
152500000-E	610	10,000	TON	ASPHALT CONC SURFACE COURSE, TYPE SF9.5A	443500000-N	1135	75	EA	CONES	604200000-E	1632	200	LF	1/4" HARDWARE CLOTH
156000000-E	620	890	TON	ASPHALT BINDER FOR PLANT MIX, GRADE PG 64-22	444500000-E	1145	96	LF	BARRICADES (TYPE III)	604400000-E	1660	6.5	ACR	SEEDING & MULCHING
202200000-E	815	23	CY	SUBDRAIN EXCAVATION	445000000-N	1150	1,200	HR	FLAGGER	608700000-E	1660	1	ACR	MOWING
203300000-E	815	17	CY	SUBDRAIN FINE AGGREGATE	451000000-N	SP	40	HR	POLICE	609000000-E	1661	50	LB	SEED FOR REPAIR SEEDING
204400000-E	815	100	LF	6" PERFORATED SUBDRAIN PIPE	468500000-E	1205	87,614	LF	THERMOPLASTIC PAVEMENT MARKING LINES (4", 90 MILS)	609300000-E	1661	0.25	TON	FERTILIZER FOR REPAIR SEEDING
205500000-E	815	3	EA	6" SUBDRAIN PIPE WYES, TEES, & ELBOWS	468600000-E	1205	87,614	LF	THERMOPLASTIC PAVEMENT MARKING LINES (4", 120 MILS)	609600000-E	1662	50	LB	SEED FOR SUPPLEMENTAL SEEDING
206600000-N	815	1	EA	CONCRETE PAD FOR SUBDRAIN PIPE OUTLET	490000000-N	1251	548	EA	PERMANENT RAISED PAVEMENT MARKERS	610800000-E	1665	1	TON	FERTILIZER TOPDRESSING
207700000-E	815	6	LF	6" OUTLET PIPE (SUBDRAINS)	532580000-E	1510	911	LF	8" WATER LINE	611400000-N	SP	2	HR	SPECIALIZED HAND MOWING
					570900000-E	1520	750	LF	*** FORCE MAIN SEWER (3")	611700000-N	SP	12	EA	RESPONSE FOR EROSION CONTROL

5/28/99

5/28/99 11:53:56 AM

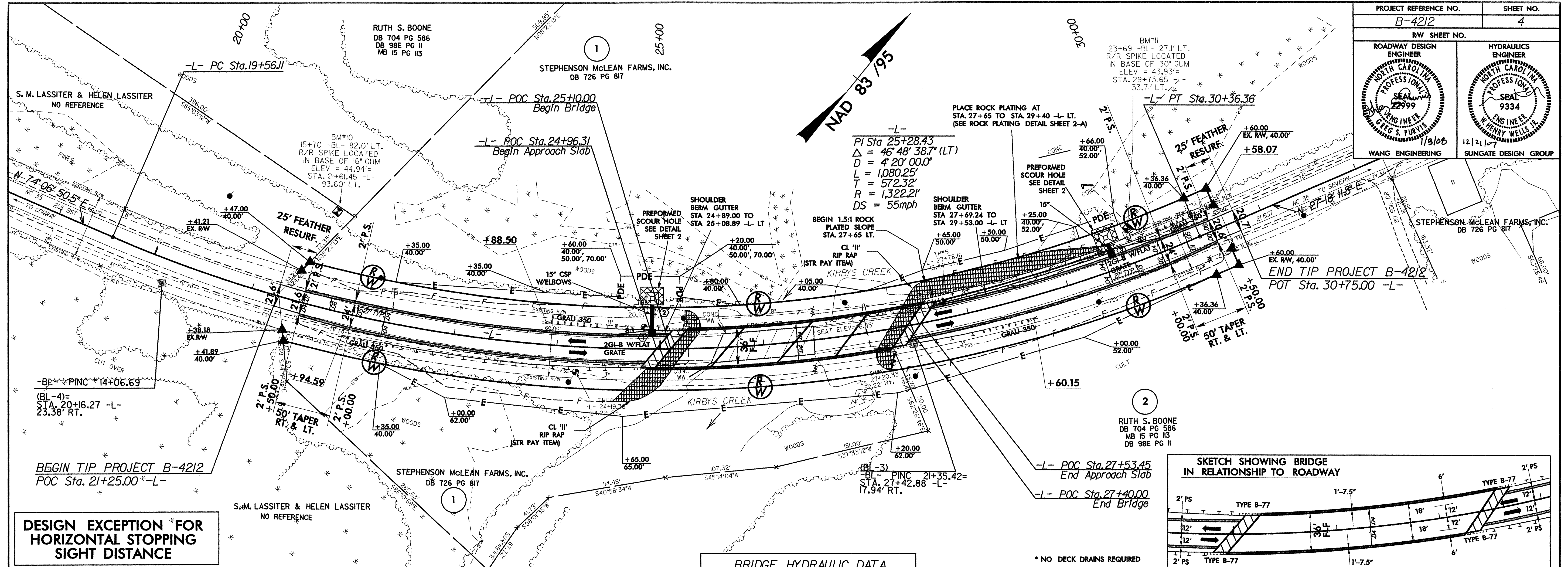

BRIDGE HYDRAULIC DATA

DESIGN DISCHARGE	= 4,320 CFS
DESIGN FREQUENCY	= 50 YR
DESIGN HW ELEVATION	= 47.3'
BASE DISCHARGE	= 5,160 CFS
BASE FREQUENCY	= 100 YR
BASE HW ELEVATION	= 48.1'
OVERTOPPING DISCHARGE	= 6,420+ CFS
OVERTOPPING FREQUENCY	= +500 YR
OVERTOPPING ELEVATION	= 50.0'
DATE OF SURVEY	= 3/5/05
W.S. ELEVATION AT DATE OF SURVEY	= 40.75'

SEE STRUCTURE PLANS S-1 THRU S-15

