

STATE	STATE PROJECT REFERENCE NO.	SHEET NO.	TOTAL SHEETS
N.C.	B-4112	1	
WBS PROJ. NO.	P.A. PROJ. NO.	DESCRIPTION	
33467.1.1	BRZ-1631(2)	P.E.	
33467.2.1	BRZ-1631(2)	RW & UTIL	
33467.3.1	BRZ-1631(2)	CONST.	

STATE OF NORTH CAROLINA
DIVISION OF HIGHWAYS

FORSYTH COUNTY

LOCATION: BRIDGE NO. 30 OVER MUDDY CREEK ON SR 1631 (MIZPAH CHURCH ROAD)

TYPE OF WORK: GRADING, DRAINAGE, PAVING & STRUCTURE

See Sheet 1-A For Index of Sheets
See Sheet 1-B For Conventional Symbols

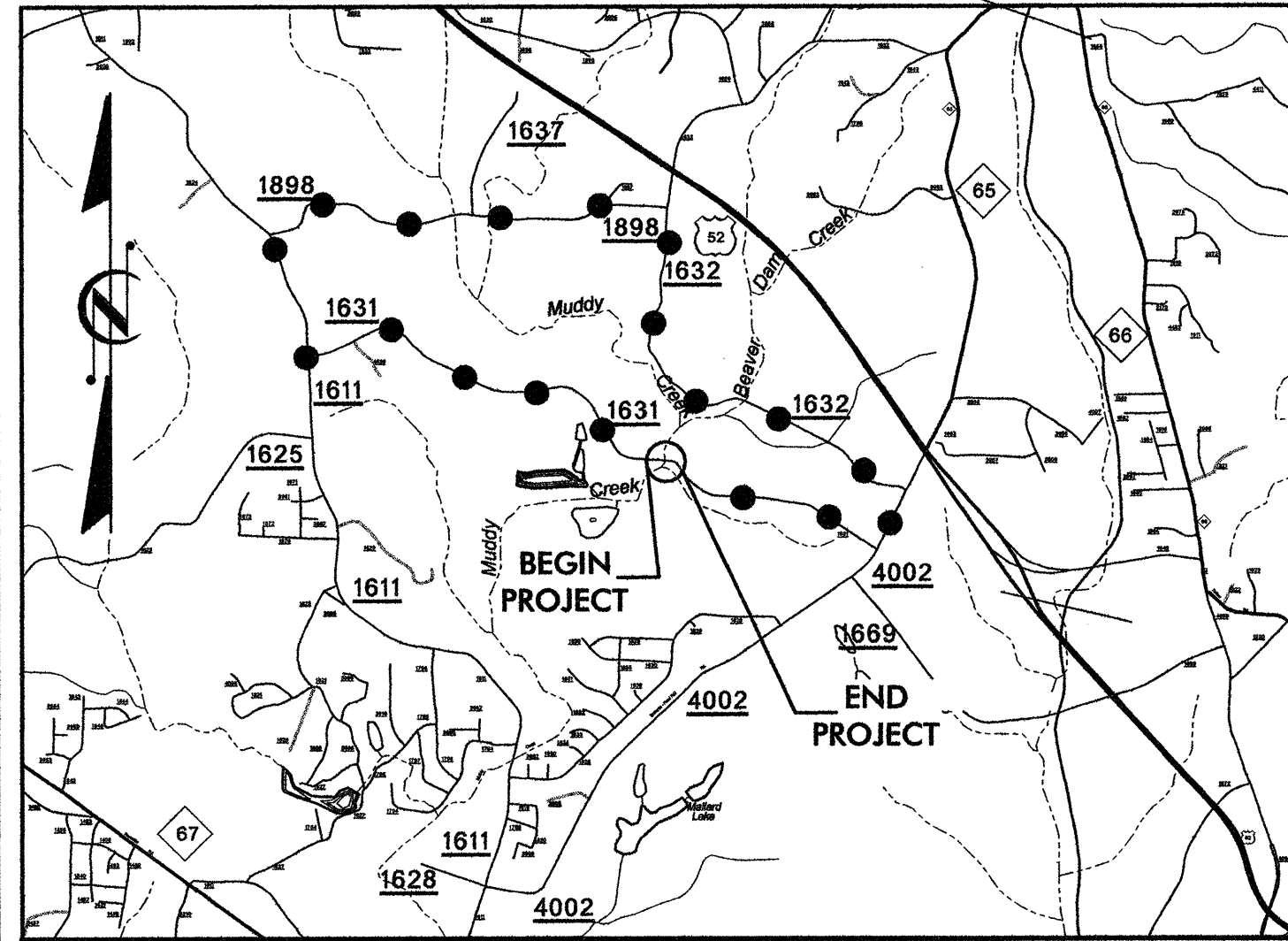

VICINITY MAP

●●●●● PROPOSED OFFSITE DETOUR

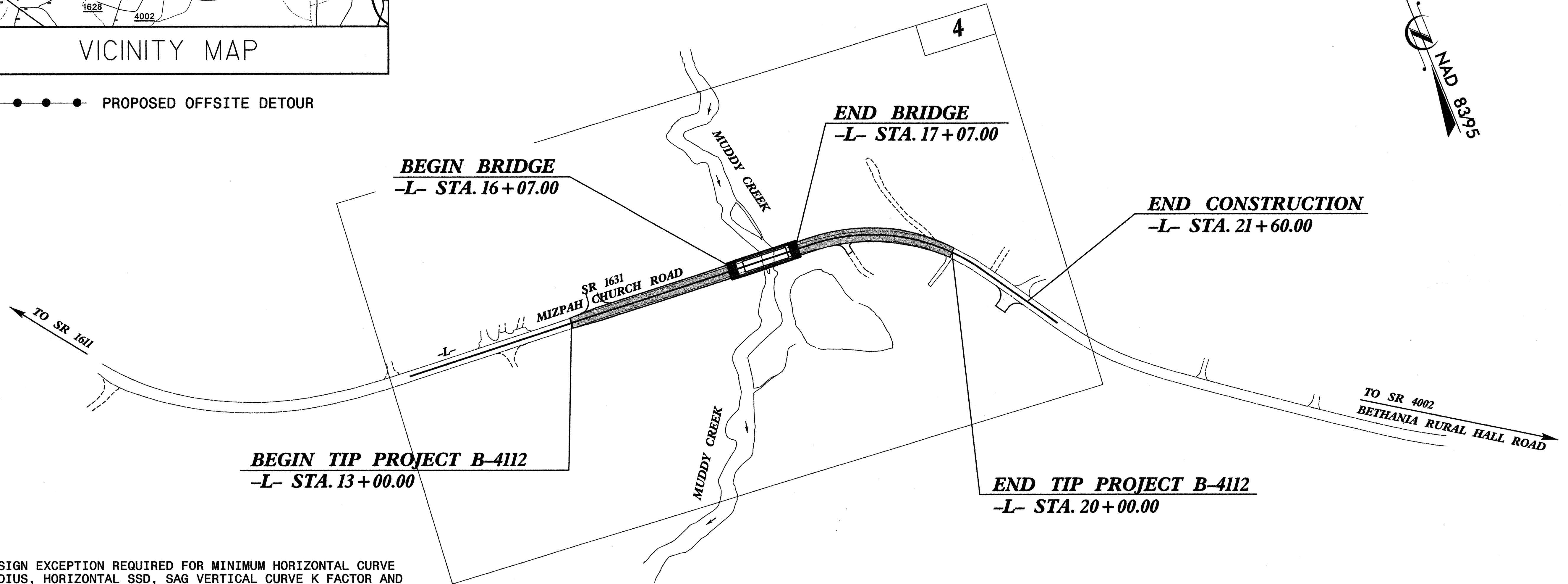

** DESIGN EXCEPTION REQUIRED FOR MINIMUM HORIZONTAL CURVE RADIUS, HORIZONTAL SSD, SAG VERTICAL CURVE K FACTOR AND MINIMUM BRIDGE WIDTH

NCDOT CONTACT: CATHY HOUSER, P.E.
ROADWAY DESIGN - ENGINEERING COORDINATION

CONTRACT: C201759 TIP PROJECT: B-4112

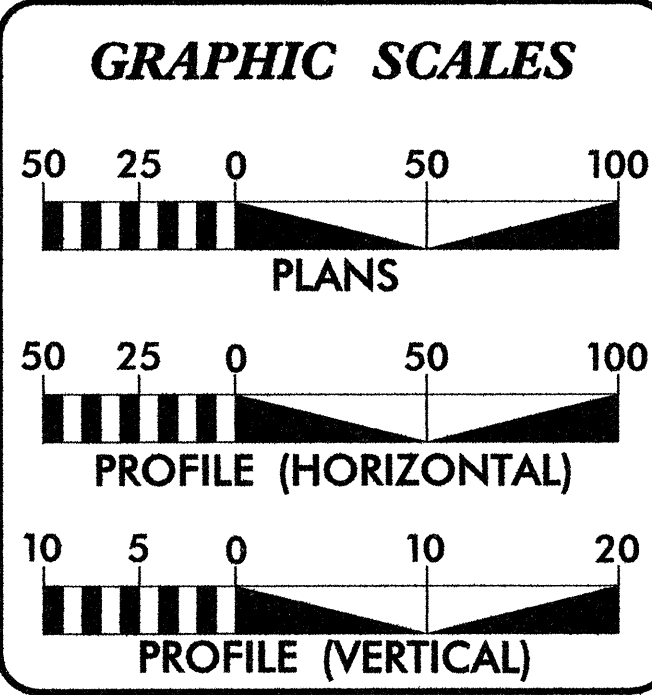

DESIGN DATA

(RURAL LOCAL)

ADT 2008 = 1635
ADT 2028 = 2535
DHV = 10 %
D = 65 %
T = 3 % *
** V = 50 MPH
* TTST 1% DUAL 2%

PROJECT LENGTH

LENGTH ROADWAY TIP PROJECT B-4112	=	0.114 MI.
LENGTH STRUCTURE TIP PROJECT B-4112	=	0.019 MI.
TOTAL LENGTH OF TIP PROJECT B-4112	=	0.133 MI.

Prepared in the Office of:
KO & ASSOCIATES, P.C.
Consulting Engineers
1011 Schaub Dr. Suite 202, Raleigh, NC 27606
(919) 851-6066

2006 STANDARD SPECIFICATIONS

RIGHT OF WAY DATE: AUGUST 29, 2006

LETTING DATE: JANUARY 15, 2008

STEPHEN R. WHITLEY, PE
PROJECT ENGINEER

DAVID C. WALLER, PE
PROJECT DESIGN ENGINEER

HYDRAULICS ENGINEER

ROADWAY DESIGN ENGINEER

SIGNATURE: *Stephen R. Whitley* 2/23/07

SIGNATURE: *David C. Waller* 2/23/07

Professional Engineer Seals for Stephen R. Whitley (Seal 19732) and David C. Waller (Seal 20774).

DIVISION OF HIGHWAYS
STATE OF NORTH CAROLINA

cut miller P.E.
STATE HIGHWAY DESIGN ENGINEER

8/23/2007 F:\Roadway\Proj\B4112-Rdy.-tsh.dgn Ko & Associates, P.C.

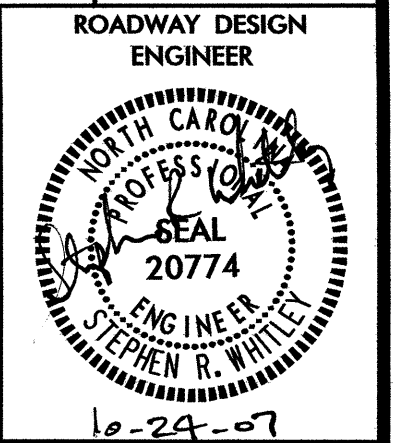

INDEX OF SHEETS

SHEET NUMBER	DESCRIPTION
1	Title Sheet
1-A	Index of Sheets, General Notes and Roadway Standard Drawings
1-B	Conventional Symbols
1-C	Survey Control Sheet
2 thru 2-A	Typical Sections and Pavement Schedule
2-B	Detail (Anchorage for Frames)
3	Summary of Quantities
3-A	Earthwork Summary, Drainage Summary, Guardrail Summary and Pavement Removal Summary
4	Plan Sheet
5	Profile Sheet
TCP-1 thru TCP-2	Traffic Control Plans
EC-1 thru EC-5	Erosion Control Plans
SIGN-1 thru SIGN-4	Signing Plans
UO-1 thru UO-2	Utilities by Others
X-1	Cross-Section Summary Sheet
X-2 thru X-6	Cross-Sections
S-1 thru S-18	Structure Plans

STANDARD DRAWINGS

EFF. 07-18-06
 REV. 01-02-07

2006 ROADWAY ENGLISH STANDARD DRAWINGS

The following Roadway Standards as appear in "Roadway Standard Drawings" Highway Design Branch - N. C. Department of Transportation - Raleigh, N. C., Dated July 18, 2006 are applicable to this project and by reference hereby are considered a part of these plans:

STD. NO.	TITLE
DIVISION 2 - EARTHWORK	
200.03	Method of Clearing - Method III
225.02	Guide for Grading Subgrade - Secondary and Local
225.04	Method of Obtaining Super-elevation - Two Lane Pavement
DIVISION 3 - PIPE CULVERTS	
300.01	Method of Pipe Installation - Method 'A'
310.10	Driveway Pipe Construction
DIVISION 4 - MAJOR STRUCTURES	
422.10	Reinforced Bridge Approach Fills
DIVISION 5 - SUBGRADE, BASES AND SHOULDERS	
560.01	Method of Shoulder Construction - High Side of Super-elevated Curve - Method I
DIVISION 8 - INCIDENTALS	
806.01	Concrete Right-of-Way Marker
806.02	Granite Right-of-Way Marker
840.00	Concrete Base Pad for Drainage Structures
840.19	Concrete Grated Drop Inlet Type 'D' - 12" thru 36" Pipe
840.22	Frames and Wide Slot Sag Grates
840.28	Brick Grated Drop Inlet Type 'D' - 12" thru 36" Pipe
840.29	Frames and Narrow Slot Flat Grates
840.35	Traffic Bearing Grated Drop Inlet - for Cast Iron Double Frame and Grates
840.46	Traffic Bearing Precast Drainage Structure
846.01	Concrete Curb, Gutter and Curb & Gutter
846.04	Drainage Installation in Shoulder Berm Gutter
848.02	Driveway Turnout - Radius Type
862.01	Guardrail Placement
862.02	Guardrail Installation
862.03	Structure Anchor Units
862.04	Anchoring End of Guardrail - B-77 and B-83 Anchor Units
876.01	Rip Rap in Channels
876.02	Guide for Rip Rap at Pipe Outlets
876.04	Drainage Ditches with Class 'B' Rip Rap

GENERAL NOTES

GENERAL NOTES: 2006 SPECIFICATIONS
 EFFECTIVE: 07-18-06
 REVISED: 07-18-06

GRADING AND SURFACING OR RESURFACING AND WIDENING:

THE GRADE LINES SHOWN DENOTE THE FINISHED ELEVATION OF THE PROPOSED SURFACING AT GRADE POINTS SHOWN ON THE TYPICAL SECTIONS. WHERE NO GRADE LINES ARE SHOWN, THE PROFILES SHOWN DENOTE THE TOP ELEVATION OF THE EXISTING PAVEMENT ALONG THE CENTER LINE OF SURVEY ON WHICH THE PROPOSED RESURFACING WILL BE PLACED. GRADE LINES MAY BE ADJUSTED BY THE ENGINEER IN ORDER TO SECURE A PROPER TIE-IN.

CLEARING:

CLEARING ON THIS PROJECT SHALL BE PERFORMED TO THE LIMITS ESTABLISHED BY METHOD III.

SUPERELEVATION:

ALL CURVES ON THIS PROJECT SHALL BE SUPERELEVATED IN ACCORDANCE WITH STD. NO. 225.04 USING THE RATE OF SUPERELEVATION AND RUNOFF SHOWN ON THE PLANS. SUPERELEVATION IS TO BE REVOLVED ABOUT THE GRADE POINTS SHOWN ON THE TYPICAL SECTIONS.

SHOULDER CONSTRUCTION:

ASPHALT, EARTH, AND CONCRETE SHOULDER CONSTRUCTION ON THE HIGH SIDE OF SUPERELEVATED CURVES SHALL BE IN ACCORDANCE WITH STD. NO. 560.01.

SIDE ROADS:

THE CONTRACTOR WILL BE REQUIRED TO DO ALL NECESSARY WORK TO PROVIDE SUITABLE CONNECTIONS WITH ALL ROADS, STREETS, AND DRIVES ENTERING THIS PROJECT. THIS WORK WILL BE PAID FOR AT THE CONTRACT UNIT PRICE FOR THE PARTICULAR ITEMS INVOLVED.

DRIVEWAYS:

DRIVEWAYS SHALL BE CONSTRUCTED IN ACCORDANCE WITH STD. 848.02 USING 3' RADII OR RADII AS SHOWN ON THE PLANS. LOCATIONS OF DRIVES WILL BE AS SHOWN ON THE PLANS OR AS DIRECTED BY THE ENGINEER.

GUARDRAIL:

THE GUARDRAIL LOCATIONS SHOWN ON THE PLANS MAY BE ADJUSTED DURING CONSTRUCTION AS DIRECTED BY THE ENGINEER. THE CONTRACTOR SHOULD CONSULT WITH THE ENGINEER PRIOR TO ORDERING GUARDRAIL MATERIAL.

TEMPORARY SHORING:

SHORING REQUIRED FOR THE MAINTENANCE OF TRAFFIC WILL BE PAID FOR AS "EXTRA WORK" IN ACCORDANCE WITH SECTION 104-7.

SUBSURFACE PLANS:

NO SUBSURFACE PLANS ARE AVAILABLE ON THIS PROJECT. THE CONTRACTOR SHOULD MAKE HIS OWN INVESTIGATION AS TO THE SUBSURFACE CONDITIONS.

END BENTS:

THE ENGINEER SHALL CHECK THE STRUCTURE END BENT PLANS, DETAILS, AND CROSS-SECTION PRIOR TO SETTING OF THE SLOPE STAKES FOR THE EMBANKMENT OR EXCAVATION APPROACHING A BRIDGE.

UTILITIES:

UTILITY OWNERS ON THIS PROJECT ARE DUKE POWER, Alltel and the City of Winston Salem

ANY RELOCATION OF EXISTING UTILITIES WILL BE ACCOMPLISHED BY OTHERS.

RIGHT-OF-WAY MARKERS:

ALL RIGHT-OF-WAY MARKERS ON THIS PROJECT SHALL BE PLACED BY CONTRACT.













Note: Not to Scale

*S.U.E. = Subsurface Utility Engineering











STATE OF NORTH CAROLINA
DIVISION OF HIGHWAYS

CONVENTIONAL PLAN SHEET SYMBOLS











BOUNDARIES AND PROPERTY:

State Line	_____
County Line	_____
Township Line	_____
City Line	_____
Reservation Line	_____
Property Line	_____
Existing Iron Pin	_____ 
Property Corner	_____ 
Property Monument	_____ 
Parcel/Sequence Number	_____ 
Existing Fence Line	_____ 
Proposed Woven Wire Fence	_____ 
Proposed Chain Link Fence	_____ 
Proposed Barbed Wire Fence	_____ 
Existing Wetland Boundary	_____ 
Proposed Wetland Boundary	_____ 
Existing Endangered Animal Boundary	_____ 
Existing Endangered Plant Boundary	_____ 



BUILDINGS AND OTHER CULTURE:

Gas Pump Vent or U/G Tank Cap	_____ 
Sign	_____ 
Well	_____ 
Small Mine	_____ 
Foundation	_____ 
Area Outline	_____ 
Cemetery	_____ 
Building	_____ 
School	_____ 
Church	_____ 
Dam	_____ 





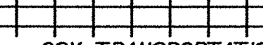
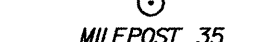
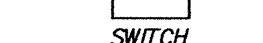
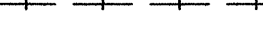







HYDROLOGY:

Stream or Body of Water	_____ 
Hydro, Pool or Reservoir	_____ 
Jurisdictional Stream	_____ 
Buffer Zone 1	_____ 
Buffer Zone 2	_____ 
Flow Arrow	_____ 
Disappearing Stream	_____ 
Spring	_____ 
Wetland	_____ 
Proposed Lateral, Tail, Head Ditch	_____ 
False Sump	_____ 













RAILROADS:

Standard Gauge	_____ 
RR Signal Milepost	_____ 
Switch	_____ 
RR Abandoned	_____ 
RR Dismantled	_____ 







RIGHT OF WAY:

Baseline Control Point	_____ 
Existing Right of Way Marker	_____ 
Existing Right of Way Line	_____ 
Proposed Right of Way Line	_____ 
Proposed Right of Way Line with Iron Pin and Cap Marker	_____ 
Proposed Right of Way Line with Concrete or Granite Marker	_____ 
Existing Control of Access	_____ 
Proposed Control of Access	_____ 
Existing Easement Line	_____ 
Proposed Temporary Construction Easement	_____ 
Proposed Temporary Drainage Easement	_____ 
Proposed Permanent Drainage Easement	_____ 
Proposed Permanent Utility Easement	_____ 







ROADS AND RELATED FEATURES:

Existing Edge of Pavement	_____ 
Existing Curb	_____ 
Proposed Slope Stakes Cut	_____ 
Proposed Slope Stakes Fill	_____ 
Proposed Wheel Chair Ramp	_____ 
Proposed Wheel Chair Ramp Curb Cut	_____ 
Curb Cut for Future Wheel Chair Ramp	_____ 
Existing Metal Guardrail	_____ 
Proposed Guardrail	_____ 
Existing Cable Guiderail	_____ 
Proposed Cable Guiderail	_____ 
Equality Symbol	_____ 
Pavement Removal	_____ 

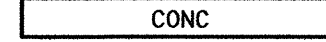

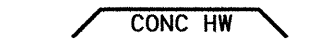
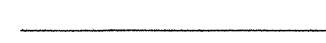
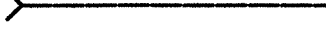
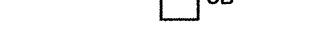







VEGETATION:

Single Tree	_____ 
Single Shrub	_____ 
Hedge	_____ 
Woods Line	_____ 
Orchard	_____ 
Vineyard	_____ 













EXISTING STRUCTURES:

MAJOR:	
Bridge, Tunnel or Box Culvert	_____ 
Bridge Wing Wall, Head Wall and End Wall	_____ 
MINOR:	
Head and End Wall	_____ 
Pipe Culvert	_____ 
Footbridge	_____ 
Drainage Box: Catch Basin, DI or JB	_____ 
Paved Ditch Gutter	_____ 
Storm Sewer Manhole	_____ 
Storm Sewer	_____ 







UTILITIES:

POWER:	
Existing Power Pole	_____ 
Proposed Power Pole	_____ 
Existing Joint Use Pole	_____ 
Proposed Joint Use Pole	_____ 
Power Manhole	_____ 
Power Line Tower	_____ 
Power Transformer	_____ 
U/G Power Cable Hand Hole	_____ 
H-Frame Pole	_____ 
Recorded U/G Power Line	_____ 
Designated U/G Power Line (S.U.E.*)	_____ 









TELEPHONE:

Existing Telephone Pole	_____ 
Proposed Telephone Pole	_____ 
Telephone Manhole	_____ 
Telephone Booth	_____ 
Telephone Pedestal	_____ 
Telephone Cell Tower	_____ 
U/G Telephone Cable Hand Hole	_____ 
Recorded U/G Telephone Cable	_____ 
Designated U/G Telephone Cable (S.U.E.*)	_____ 
Recorded U/G Telephone Conduit	_____ 
Designated U/G Telephone Conduit (S.U.E.*)	_____ 
Recorded U/G Fiber Optics Cable	_____ 
Designated U/G Fiber Optics Cable (S.U.E.*)	_____ 





WATER:

Water Manhole	_____ 
Water Meter	_____ 
Water Valve	_____ 
Water Hydrant	_____ 
Recorded U/G Water Line	_____ 
Designated U/G Water Line (S.U.E.*)	_____ 
Above Ground Water Line	_____ 







TV:

TV Satellite Dish	_____ 
TV Pedestal	_____ 
TV Tower	_____ 
U/G TV Cable Hand Hole	_____ 
Recorded U/G TV Cable	_____ 
Designated U/G TV Cable (S.U.E.*)	_____ 
Recorded U/G Fiber Optic Cable	_____ 
Designated U/G Fiber Optic Cable (S.U.E.*)	_____ 











GAS:

Gas Valve	_____ 
Gas Meter	_____ 
Recorded U/G Gas Line	_____ 
Designated U/G Gas Line (S.U.E.*)	_____ 
Above Ground Gas Line	_____ 

SANITARY SEWER:

Sanitary Sewer Manhole	_____ 
Sanitary Sewer Cleanout	_____ 
U/G Sanitary Sewer Line	_____ 
Above Ground Sanitary Sewer	_____ 
Recorded SS Forced Main Line	_____ 
Designated SS Forced Main Line (S.U.E.*)	_____ 

MISCELLANEOUS:

Utility Pole	_____ 
Utility Pole with Base	_____ 
Utility Located Object	_____ 
Utility Traffic Signal Box	_____ 
Utility Unknown U/G Line	_____ 
U/G Tank; Water, Gas, Oil	_____ 
A/G Tank; Water, Gas, Oil	_____ 
U/G Test Hole (S.U.E.*)	_____ 
Abandoned According to Utility Records	_____ 
End of Information	_____ 

6/2/99

8/22/2007 10:41:12 AM C:\Users\p1\Documents\Projects\B4112\1s-1c.dgn

SURVEY CONTROL SHEET B-4112

PROJECT REFERENCE NO.	SHEET NO.
B4112	1C
Location and Surveys	

BL POINT	DESC.	NORTH	EAST	ELEVATION	L1 STATION	OFFSET
B4112-1	B4112-1	897908.1810	1608545.3820	841.90	OUTSIDE PROJECT LIMITS	
B4112-2	B4112-2	897880.8380	1609510.7740	827.77	18+13.23	21.53 LT
BL-3	BL-3	897526.4630	1609799.3760	844.79	OUTSIDE PROJECT LIMITS	

 BM*1 ELEVATION = 844.78
 N 897920 E 1608501
 FROM -L- STATION 10+00
 S 89° 11' 01.6" W DIST 193.70'
 R/R SPIKE SET IN 12" PINE

 BM*2 ELEVATION = 830.60
 N 897479 E 1609809
 FROM -L- STATION 22+24.67
 S 11° 49' 34.4" E DIST 101.74'
 R/R SPIKE SET IN 12" WALNUT

 BM*3 ELEVATION = 812.87
 N 898112 E 1609338
 -L- STATION 16+29 233' LEFT
 R/R SPIKE SET IN 14" ASH

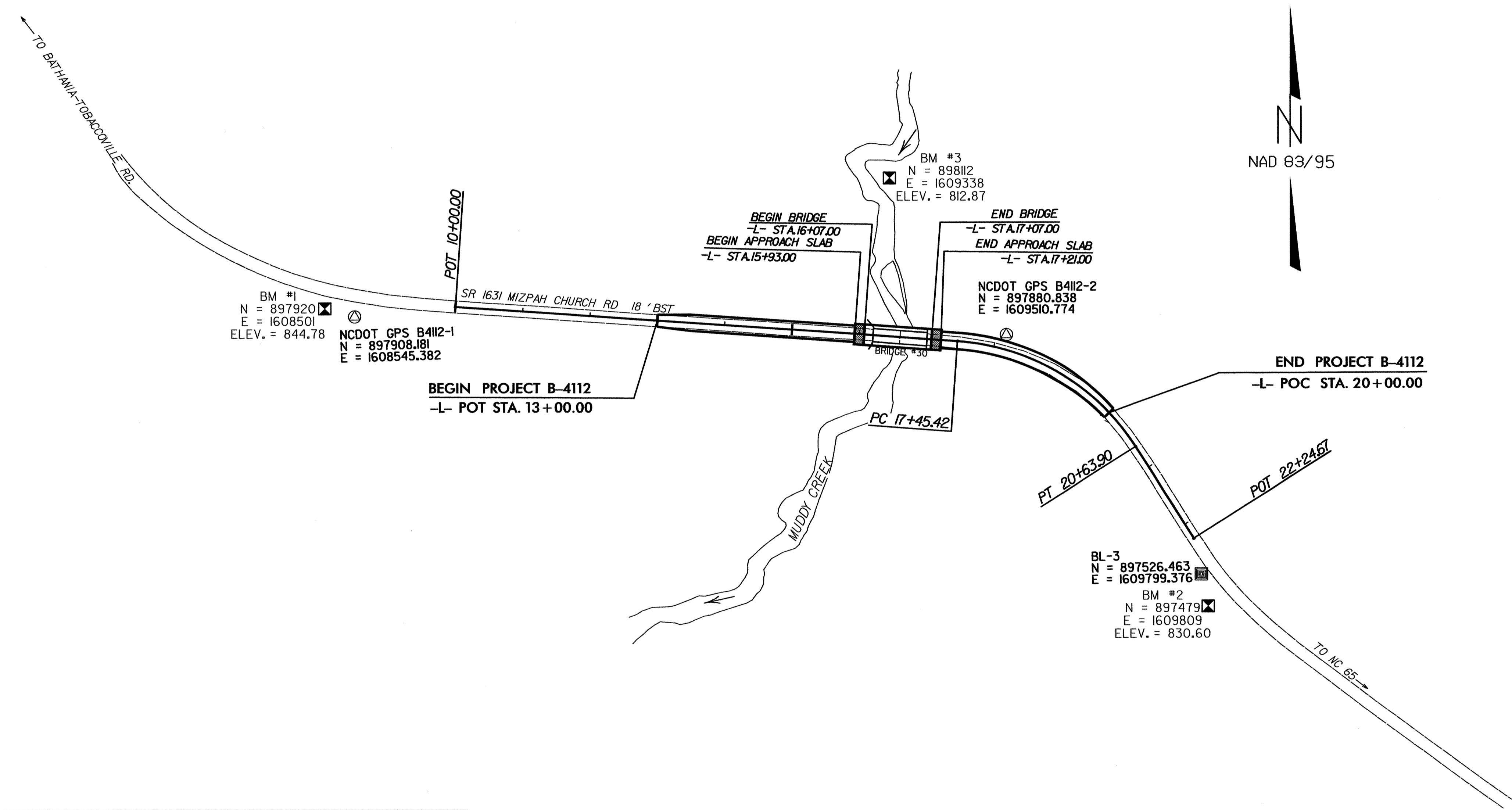

DATUM DESCRIPTION

THE LOCALIZED COORDINATE SYSTEM DEVELOPED FOR THIS PROJECT IS BASED ON THE STATE PLANE COORDINATES ESTABLISHED BY NCDOT FOR MONUMENT "B4112-1"

WITH NAD 83/95 STATE PLANE GRID COORDINATES OF
 NORTHING: 897908.181(ft) EASTING: 1608545.382(ft)
 THE AVERAGE COMBINED GRID FACTOR USED ON THIS PROJECT (GROUND TO GRID) IS: 0.99997735

THE N.C. LAMBERT GRID BEARING AND LOCALIZED HORIZONTAL GROUND DISTANCE FROM "B4112-1" TO -L- STATION 13+00.00 IS
 N 89° 13' 27.34" E 448.63'

ALL LINEAR DIMENSIONS ARE LOCALIZED HORIZONTAL DISTANCES
 VERTICAL DATUM USED IS NAVD 88

NOTE: DRAWING NOT TO SCALE

NOTES:

1. THE CONTROL DATA FOR THIS PROJECT CAN BE FOUND ELECTRONICALLY BY SELECTING PROJECT CONTROL DATA AT:
[HTTP://WWW.NCDOT.ORG/DOH/PRECONSTRUCT/HIGHWAY/LOCATION/PROJECT/](http://www.ncdot.org/DOH/PRECONSTRUCT/HIGHWAY/LOCATION/PROJECT/)

THE FILES TO BE FOUND ARE AS FOLLOWS:
 TIP B4112_LS_CONTROL_DATE.HTML

SITE CALIBRATION INFORMATION HAS NOT BEEN PROVIDED FOR THIS PROJECT. IF FURTHER INFORMATION IS NEEDED, PLEASE CONTACT THE LOCATION AND SURVEYS UNIT.

⊗ INDICATES GEODETIC CONTROL MONUMENTS USED OR SET FOR HORIZONTAL PROJECT CONTROL BY THE NCDOT LOCATION AND SURVEYS UNIT.
 PROJECT CONTROL ESTABLISHED USING GLOBAL POSITIONING SYSTEM.
 NETWORK ESTABLISHED FROM EXISTING HARN MONUMENTATION
 SEE GPS CALIBRATION SHEET FOR HORIZONTAL AND VERTICAL COORDINATE VALUES.

6/2/99

PAVEMENT SCHEDULE	
C1	PROP. APPROX. 1 1/4" ASPHALT CONCRETE SURFACE COURSE, TYPE SF9.5A, AT AN AVERAGE RATE OF 138 LBS. PER SQ. YD.
C2	PROP. APPROX. 2 1/2" ASPHALT CONCRETE SURFACE COURSE, TYPE SF9.5A, AT AN AVERAGE RATE OF 138 LBS. PER SQ. YD. IN EACH OF TWO LAYERS.
C3	PROP. VAR. DEPTH ASPHALT CONCRETE SURFACE COURSE, TYPE SF9.5A, AT AN AVERAGE RATE OF 110 LBS. PER SQ. YD. PER 1" DEPTH. TO BE PLACED IN LAYERS NOT TO EXCEED 1 1/2" IN DEPTH.
D1	PROP. APPROX. 2 1/2" ASPHALT CONCRETE INTERMEDIATE COURSE, TYPE I19.0B, AT AN AVERAGE RATE OF 285 LBS. PER SQ. YD.
D2	PROP. VAR. DEPTH ASPHALT CONCRETE INTERMEDIATE COURSE, TYPE I19.0B, AT AN AVERAGE RATE OF 114 LBS. PER SQ. YD. PER 1" DEPTH, TO BE PLACED IN LAYERS NOT LESS THAN 2 1/2" IN DEPTH OR GREATER THAN 4" IN DEPTH.
E1	PROP. APPROX. 4" ASPHALT CONCRETE BASE COURSE, TYPE B25.0B, AT AN AVERAGE RATE OF 456 LBS. PER SQ. YD.
E2	PROP. VAR. DEPTH ASPHALT CONCRETE BASE COURSE, TYPE B25.0B, AT AN AVERAGE RATE OF 114 LBS. PER SQ. YD. PER 1" DEPTH. TO BE PLACED IN LAYERS NOT LESS THAN 3" IN DEPTH OR GREATER THAN 5 1/2" IN DEPTH.
U	EXISTING PAVEMENT.
T	EARTH MATERIAL.
W	VARIABLE DEPTH ASPHALT PAVEMENT

NOTE: PAVEMENT EDGE SLOPES ARE 1:1 UNLESS SHOWN OTHERWISE.

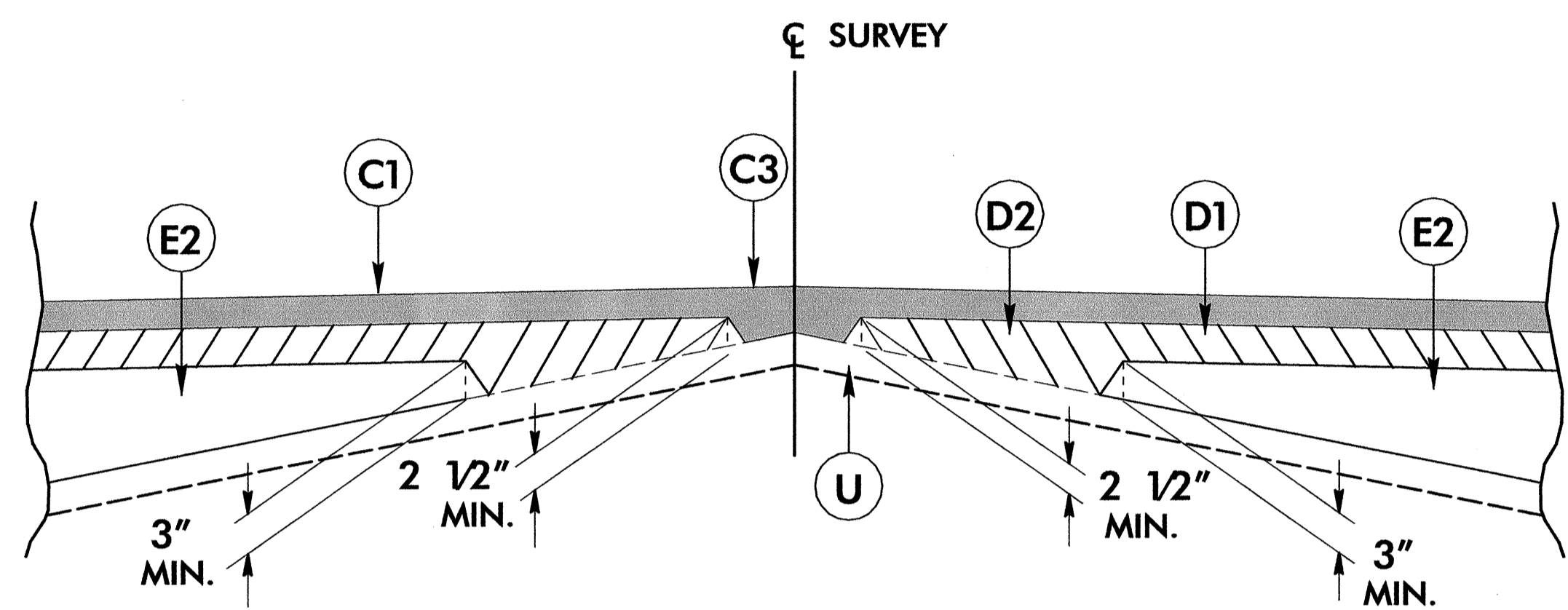

Detail Showing Method of Wedging

TRANSITION FROM EXISTING TO TYPICAL NO. 1

-L- STA. 13+00.00 TO 13+50.00

USE TYPICAL SECTION NO. 1

-L- STA. 13+50.00 TO 15+50.00
 -L- STA. 18+25.00 TO 19+00.00

TRANSITION FROM EXISTING TO TYPICAL NO. 1

-L- STA. 19+00.00 TO 20+00.00

* ADD 3' WITH GUARDRAIL

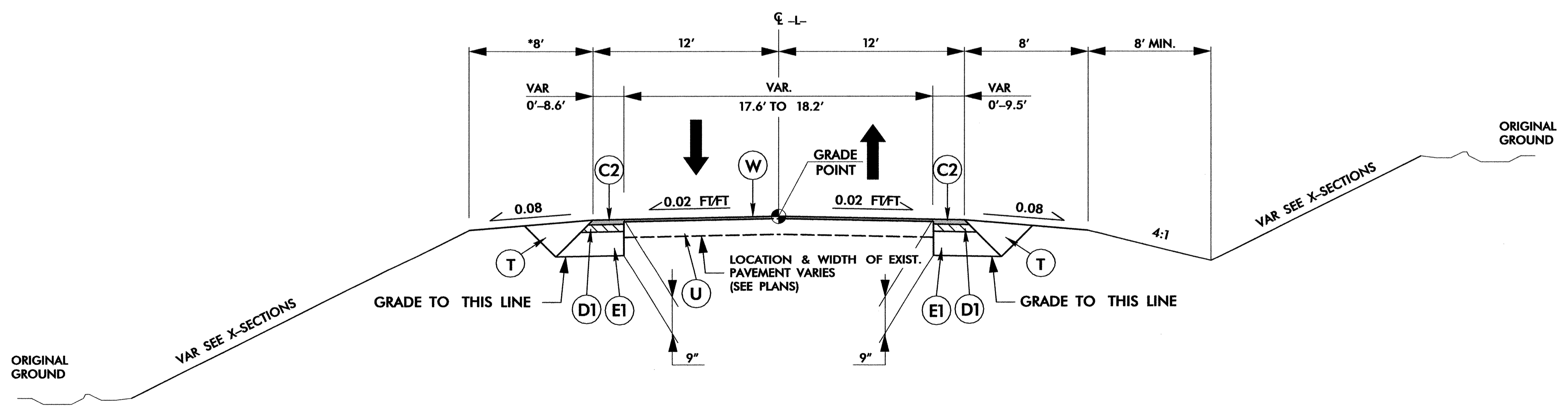

TYPICAL SECTION NO. 1

-L- (SR 1631)

8/22/2007 C:\Users\jpr\My Documents\Projects\B4112.Rdy_tjpr.dgn KO & Associates, P.C.

6/2/99

10/22/2007 1:00 PM C:\Projects\B4112.Rd\Tup.dgn

USE TYPICAL SECTION NO. 2
 -L- STA. 15+50.00 TO STA. 15+93.00 (APPROACH SLAB)
 -L- STA. 17+21.00 (APPROACH SLAB) TO STA. 18+25.00

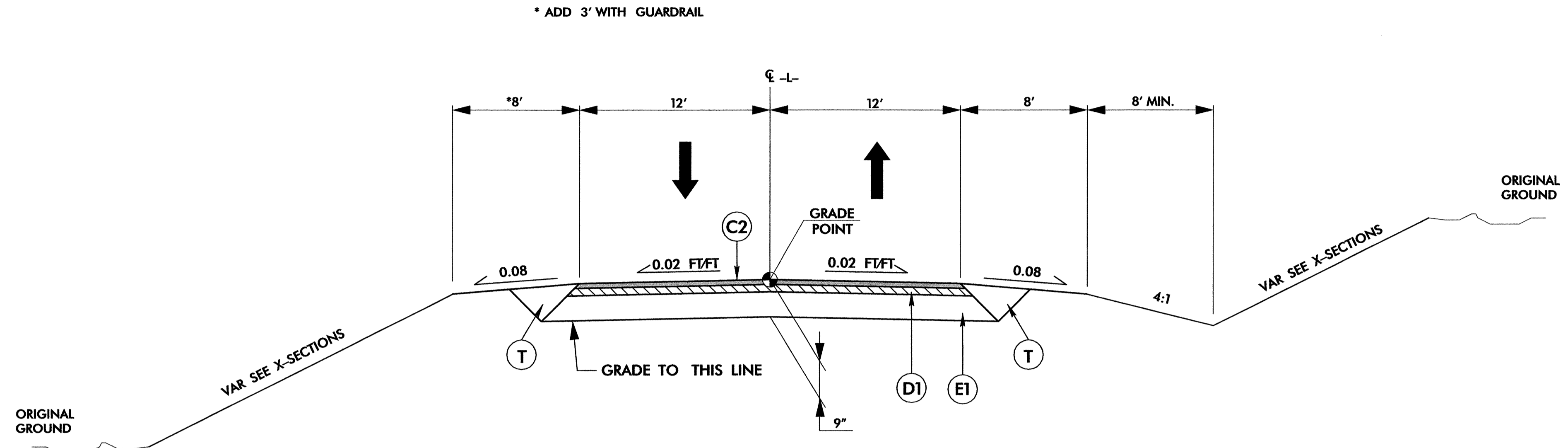

TYPICAL SECTION NO. 2
 -L- (SR 1631)

PAVEMENT SCHEDULE	
C1	PROP. APPROX. 1 1/4" ASPHALT CONCRETE SURFACE COURSE, TYPE SF9.5A, AT AN AVERAGE RATE OF 138 LBS. PER SQ. YD.
C2	PROP. APPROX. 2 1/2" ASPHALT CONCRETE SURFACE COURSE, TYPE SF9.5A, AT AN AVERAGE RATE OF 138 LBS. PER SQ. YD. IN EACH OF TWO LAYERS.
C3	PROP. VAR. DEPTH ASPHALT CONCRETE SURFACE COURSE, TYPE SF9.5A, AT AN AVERAGE RATE OF 110 LBS. PER SQ. YD. PER 1" DEPTH. TO BE PLACED IN LAYERS NOT TO EXCEED 1 1/2" IN DEPTH.
D1	PROP. APPROX. 2 1/2" ASPHALT CONCRETE INTERMEDIATE COURSE, TYPE I19.0B, AT AN AVERAGE RATE OF 285 LBS. PER SQ. YD.
D2	PROP. VAR. DEPTH ASPHALT CONCRETE INTERMEDIATE COURSE, TYPE I19.0B, AT AN AVERAGE RATE OF 114 LBS. PER SQ. YD. PER 1" DEPTH, TO BE PLACED IN LAYERS NOT LESS THAN 2 1/2" IN DEPTH OR GREATER THAN 4" IN DEPTH.
E1	PROP. APPROX. 4" ASPHALT CONCRETE BASE COURSE, TYPE B25.0B, AT AN AVERAGE RATE OF 456 LBS. PER SQ. YD.
E2	PROP. VAR. DEPTH ASPHALT CONCRETE BASE COURSE, TYPE B25.0B, AT AN AVERAGE RATE OF 114 LBS. PER SQ. YD. PER 1" DEPTH. TO BE PLACED IN LAYERS NOT LESS THAN 3" IN DEPTH OR GREATER THAN 5 1/2" IN DEPTH.
U	EXISTING PAVEMENT.
T	EARTH MATERIAL.
W	VARIABLE DEPTH ASPHALT PAVEMENT

NOTE: PAVEMENT EDGE SLOPES ARE 1:1 UNLESS SHOWN OTHERWISE.

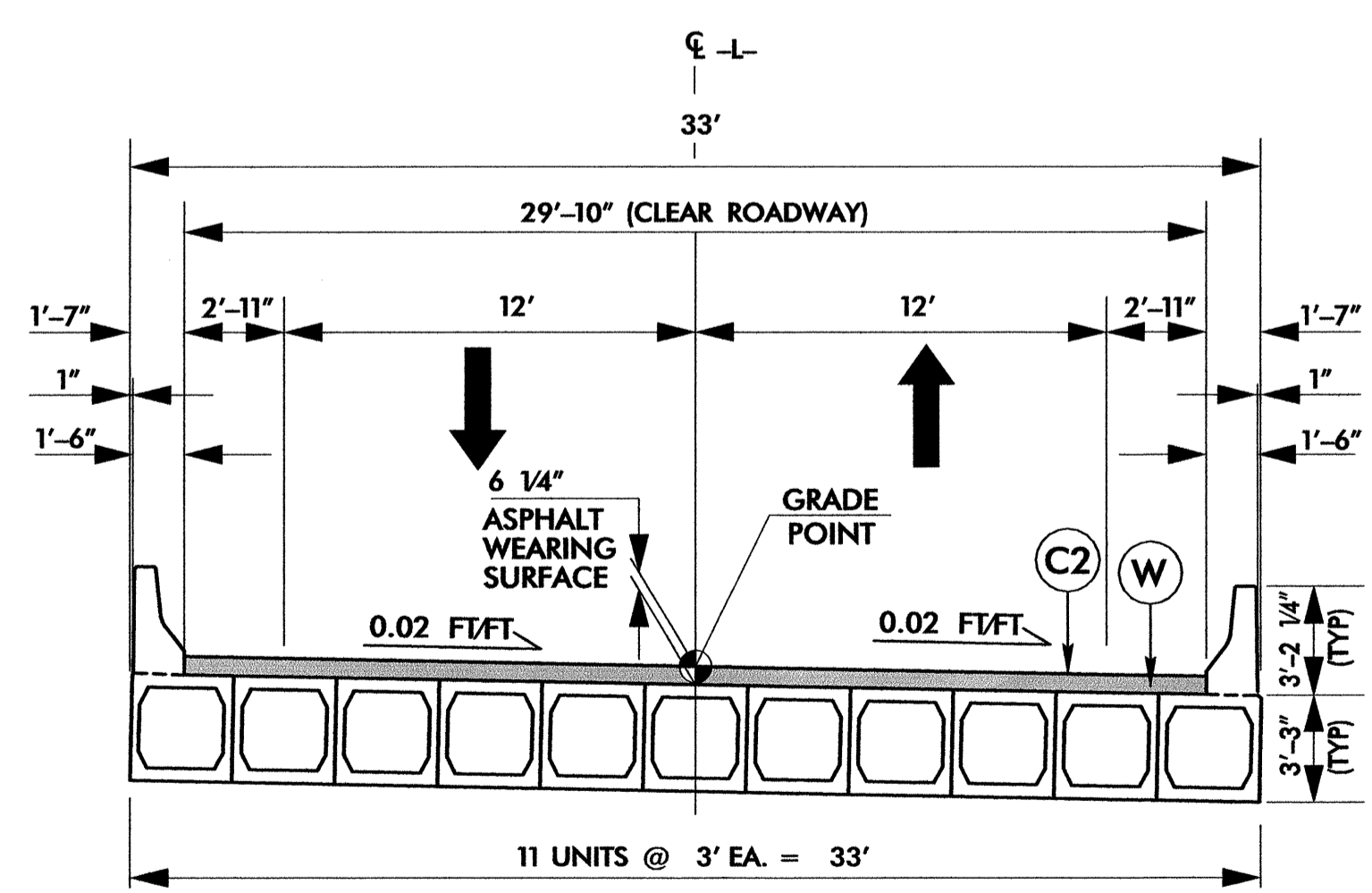

TYPICAL SECTION NO. 3
 STRUCTURE ON SR 1631

USE TYPICAL SECTION NO. 3
 -L- STA. 16+07 TO 17+07

STATE OF NORTH CAROLINA
DEPT. OF TRANSPORTATION
DIVISION OF HIGHWAYS
RALEIGH, N.C.

ENGLISH DETAIL DRAWING FOR
ANCHORAGE FOR FRAMES
BRICK/CONCRETE/PRECAST CONCRETE

SHEET 1 OF 1
840D25

STATE OF NORTH CAROLINA
DEPT. OF TRANSPORTATION
DIVISION OF HIGHWAYS
RALEIGH, N.C.

ENGLISH DETAIL DRAWING FOR
ANCHORAGE FOR FRAMES
BRICK/CONCRETE/PRECAST CONCRETE

SHEET 1 OF 1
840D25

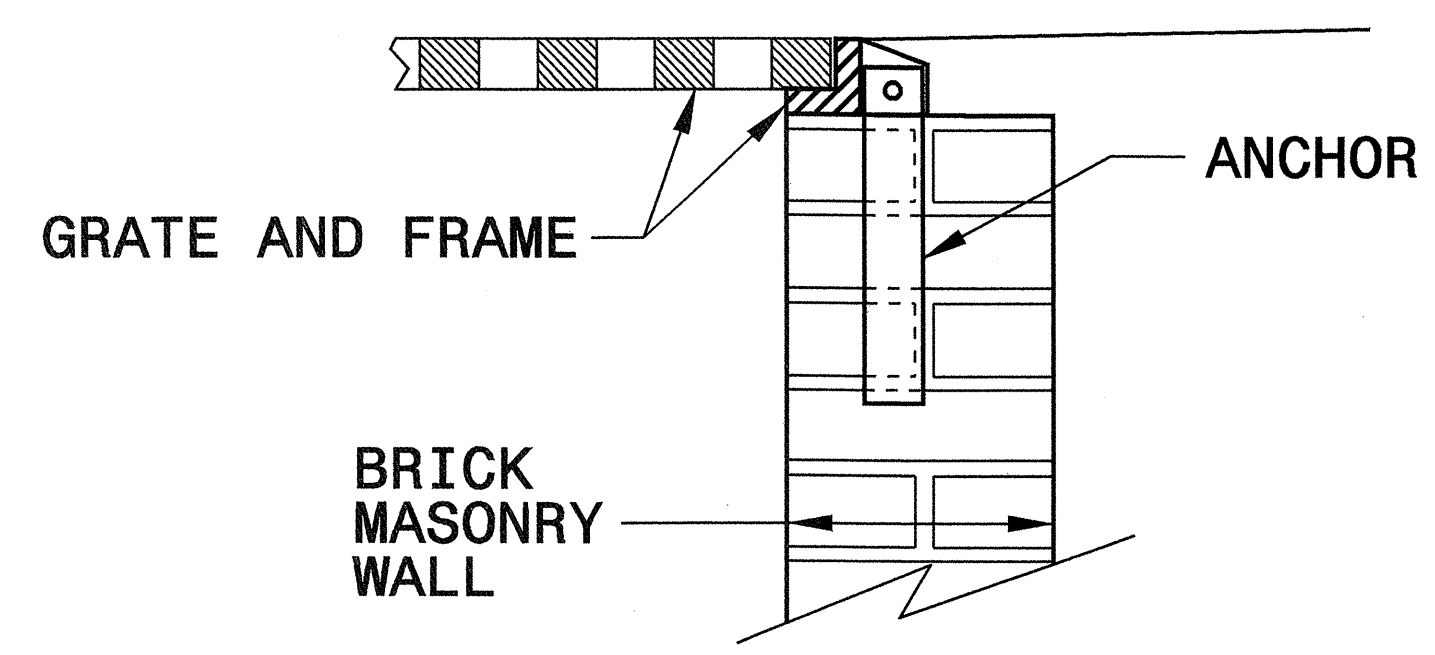

BRICK MASONRY CONSTRUCTION

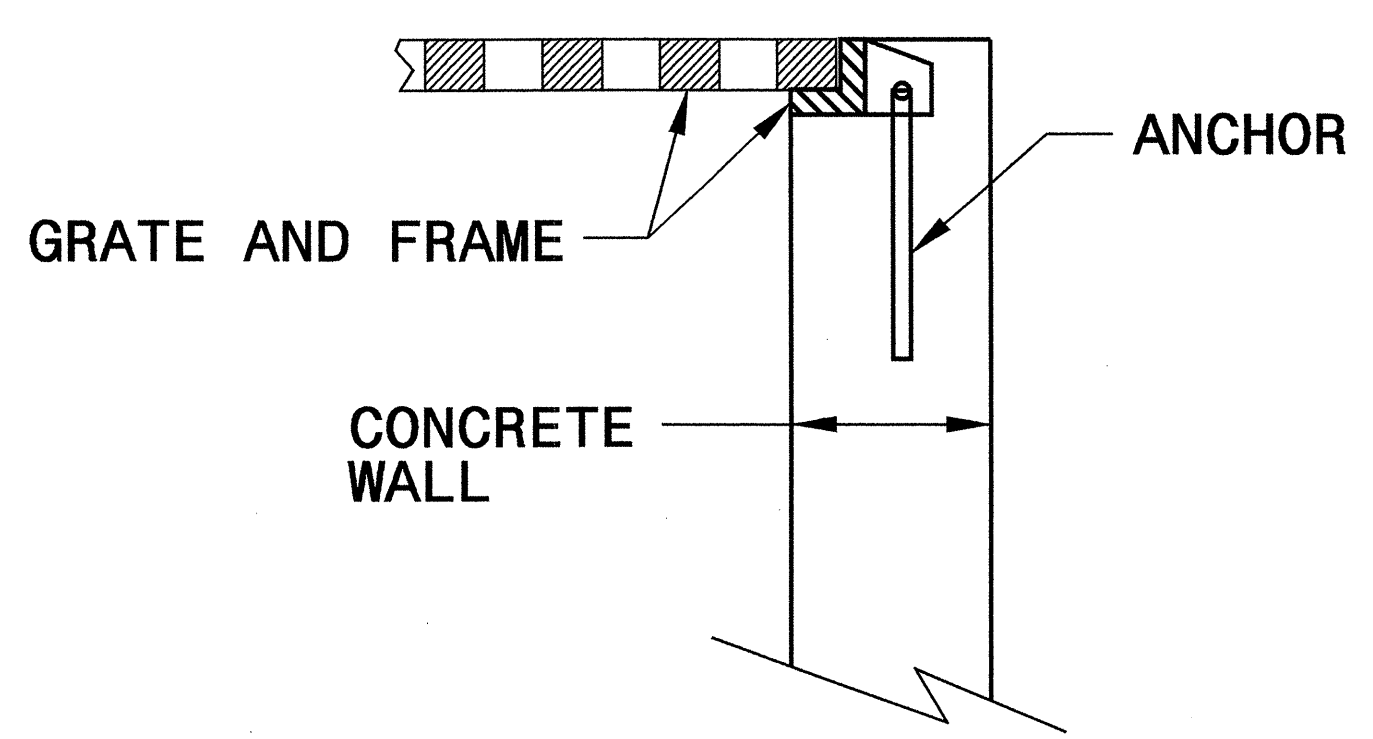

CONCRETE CONSTRUCTION

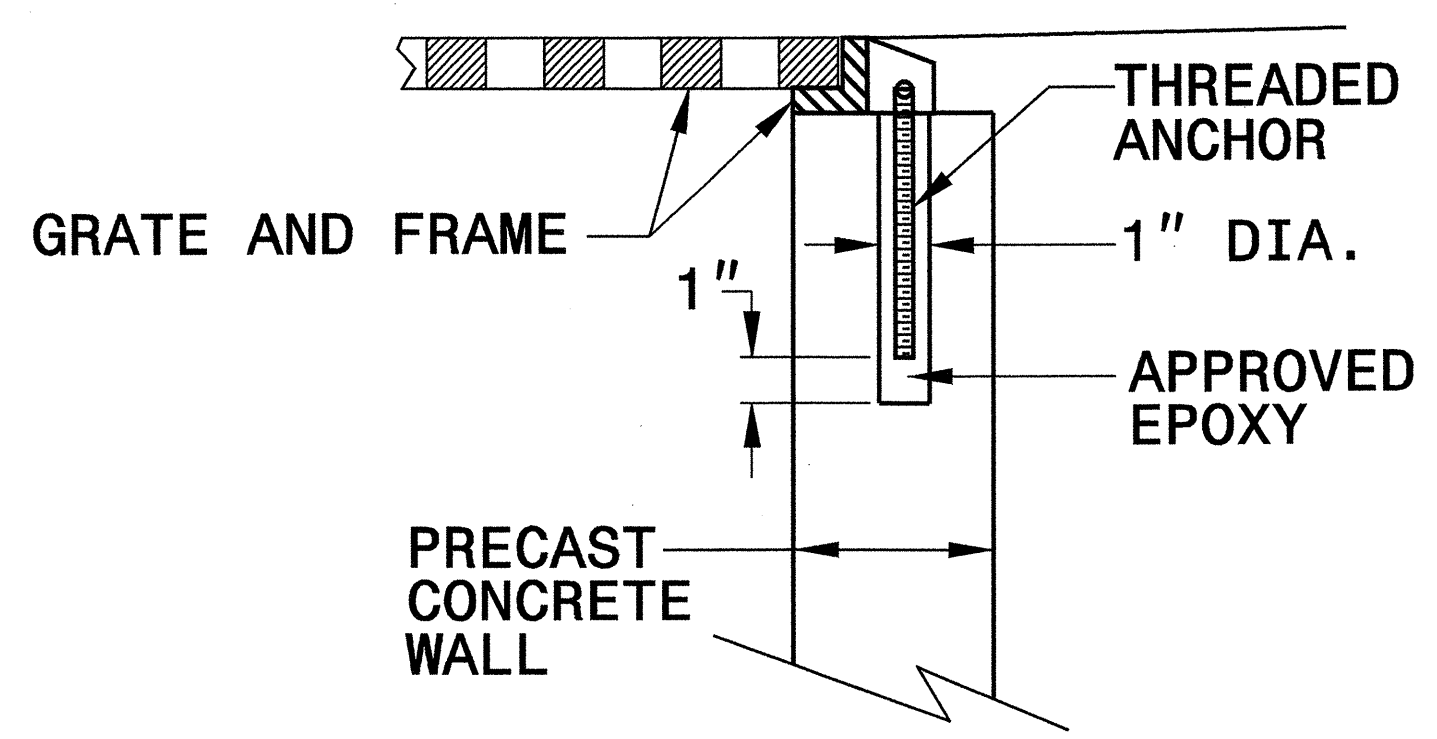

PRECAST CONCRETE CONSTRUCTION

DETAIL SHOWING ANCHORAGE OF FRAME FOR GRATED DROP INLET

NOTE:
CONSTRUCT GRATED DROP INLET TO COINCIDE WITH NORMAL OR SUPERELEVATED SHOULDER OR PAVEMENT SLOPE.

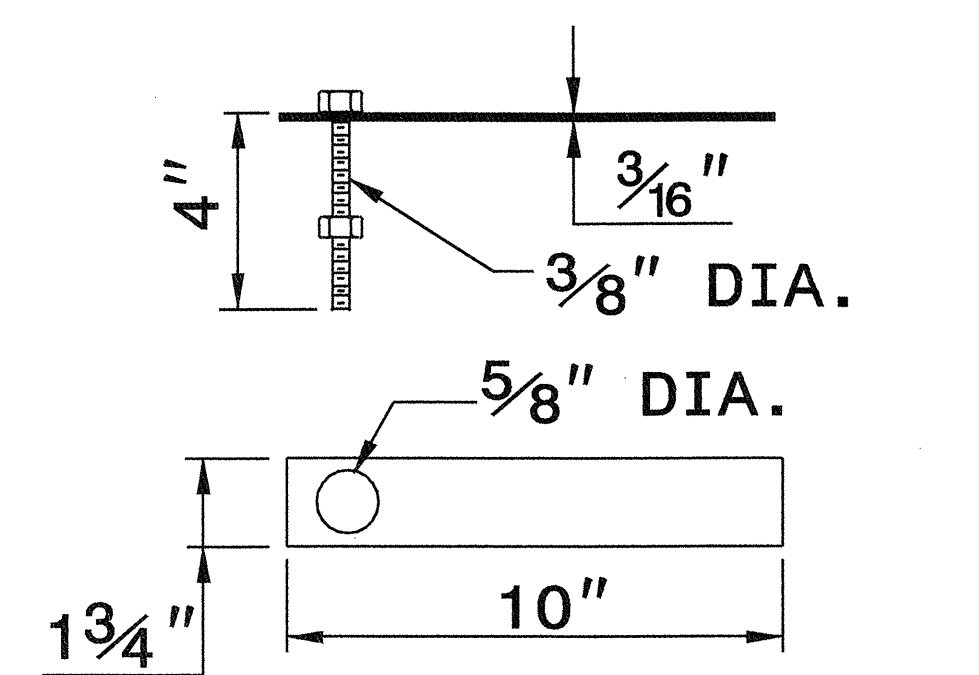

MASONRY ANCHOR
3/8" DIA. BOLT WITH PLATE

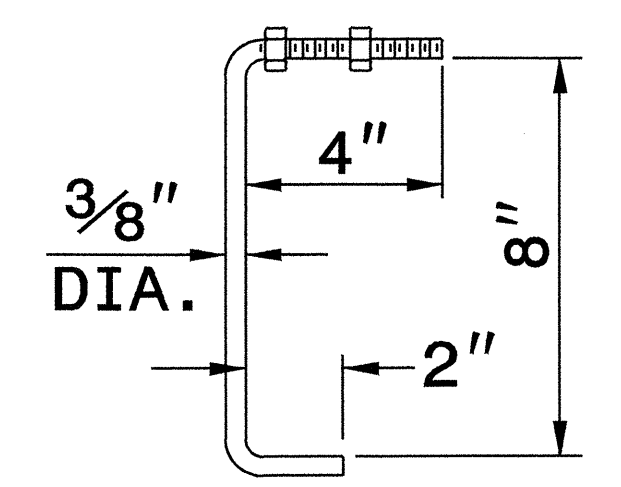

CONCRETE ANCHOR
3/8" DIA. BENT BAR

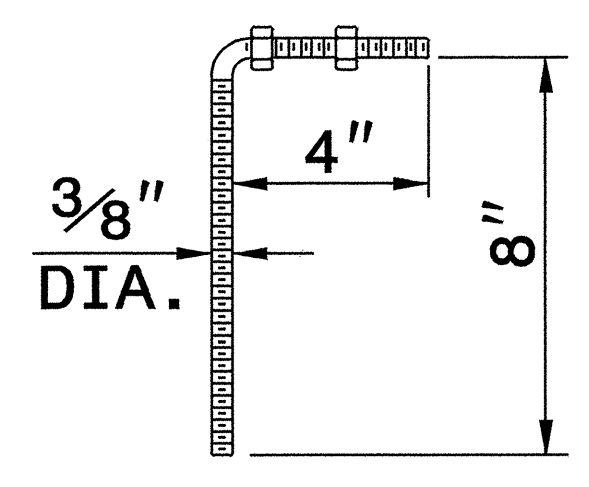

PRECAST CONCRETE ANCHOR
3/8" DIA. BENT BAR

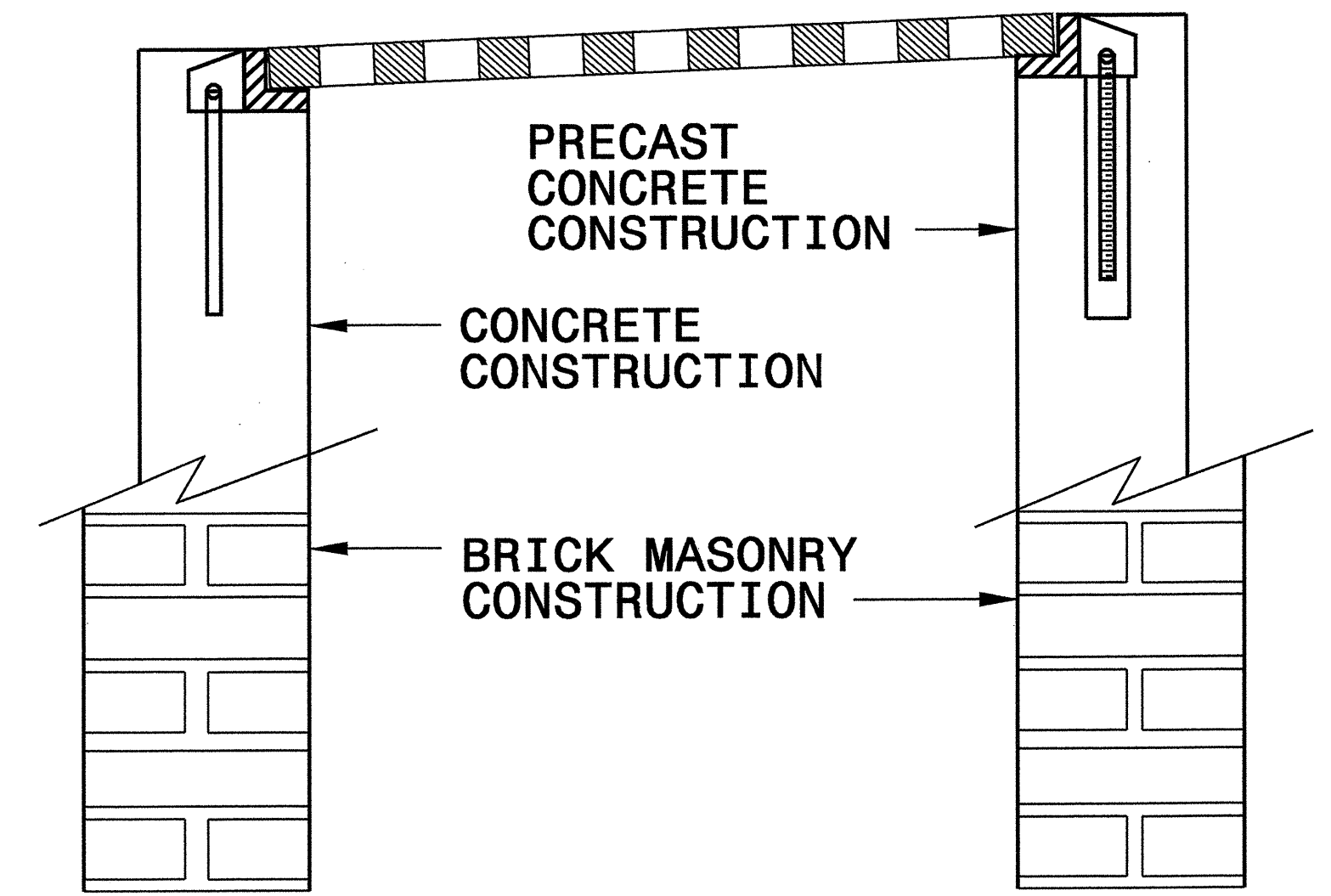

FRAME AND GRATE INSTALLATION FOR NORMAL CROWN AND SUPERELEVATED SECTIONS

01-MAR-2007 09:04 s:\contracts\contract\stds\stds\stds to special details\84025 anchorage for frames\0840d25.dgn jhowerston AT PS212260

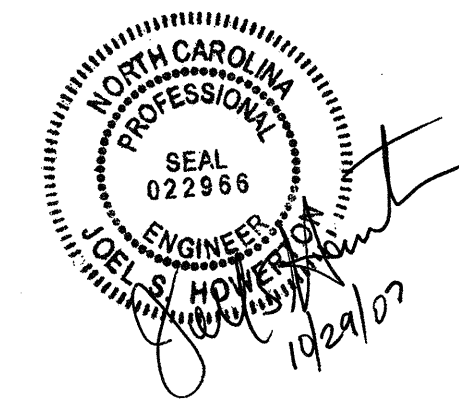

**PROJECT SERVICES UNIT
STANDARDS AND SPECIAL DESIGN**
Office 919-250-4128 FAX 919-250-4119

SEE PLATE FOR TITLE

ORIGINAL BY: 2006 STD 840.25 DATE: 07/18/06
MODIFIED BY: E.E. WARD DATE: 9/25/06
CHECKED BY: DATE:
FILE SPEC.:

SUMMARY OF QUANTITIES

STATE OF NORTH CAROLINA
DIVISION OF HIGHWAYS
ROADWAY SUMMARY OF QUANTITIES FOR CONTRACT - C201759

ItemNumber	Sec #	Quantity	Unit	Description	ItemNumber	Sec #	Quantity	Unit	Description	ItemNumber	Sec #	Quantity	Unit	Description
0000100000-N	800	Lump Sum		MOBILIZATION	3150000000-N	862	5	EA	ADDITIONAL GUARDRAIL POSTS	6036000000-E	1631	400	SY	MATTING FOR EROSION CONTROL
0029000000-N	SP	Lump Sum		REINFORCED BRIDGE APPROACH FILL, STATION ***** (16+57)	3195000000-N	862	1	EA	GUARDRAIL ANCHOR UNITS, TYPE AT-1	6038000000-E	SP	220	SY	PERMANENT SOIL REINFORCEMENT MAT
0043000000-N	226	Lump Sum		GRADING	3270000000-N	SP	3	EA	GUARDRAIL ANCHOR UNITS, TYPE 350	6042000000-E	1632	20	LF	1/4" HARDWARE CLOTH
0050000000-E	226	1	ACR	SUPPLEMENTARY CLEARING & GRUB- BING	3317000000-N	862	4	EA	GUARDRAIL ANCHOR UNITS, TYPE B-77	6071030000-E	SP	90	LF	COIR FIBER BAFFLES
0057000000-E	226	200	CY	UNDERCUT EXCAVATION	3649000000-E	876	30	TON	RIP RAP, CLASS B	6084000000-E	1660	1	ACR	SEEDING & MULCHING
0195000000-E	265	300	CY	SELECT GRANULAR MATERIAL	3656000000-E	876	200	SY	FILTER FABRIC FOR DRAINAGE	6087000000-E	1660	0.5	ACR	MOWING
0196000000-E	270	400	SY	FABRIC FOR SOIL STABILIZATION	4025000000-E	901	39	SF	CONTRACTOR FURNISHED, TYPE *** SIGN (E)	6090000000-E	1661	50	LB	SEED FOR REPAIR SEEDING
0318000000-E	300	10	TON	FOUNDATION CONDITIONING MATE- RIAL, MINOR STRS	4072000000-E	903	150	LF	SUPPORTS, 3-LB STEEL U-CHANNEL	6093000000-E	1661	0.25	TON	FERTILIZER FOR REPAIR SEEDING
0366000000-E	310	64	LF	15" RC PIPE CULVERTS, CLASS III	4102000000-N	904	6	EA	SIGN ERECTION, TYPE E	6096000000-E	1662	50	LB	SEED FOR SUPPLEMENTAL SEEDING
0708000000-E	310	16	LF	15" BIT COAT CS PIPE CULVERTS, TYPE B 0.064" THICK	4155000000-N	907	10	EA	DISPOSAL OF SIGN SYSTEM, U- CHANNEL	6108000000-E	1665	0.75	TON	FERTILIZER TOPDRESSING
0995000000-E	340	50	LF	PIPE REMOVAL	4400000000-E	1110	349	SF	WORK ZONE SIGNS (STATIONARY)	6114000000-N	SP	2	HR	SPECIALIZED HAND MOWING
1121000000-E	520	60	TON	AGGREGATE BASE COURSE	4410000000-E	1110	114	SF	WORK ZONE SIGNS (BARRICADE MOUNTED)	6117000000-N	SP	12	EA	RESPONSE FOR EROSION CONTROL
1220000000-E	545	200	TON	INCIDENTAL STONE BASE	4445000000-E	1145	64	LF	BARRICADES (TYPE III)					
1489000000-E	610	220	TON	ASPHALT CONC BASE COURSE, TYPE B25.0B	4847000000-E	1205	2,800	LF	POLYUREA PAVEMENT MARKING LINES (4", *****) (HIGHLY REFLECTIVE ELEMENTS)					
1498000000-E	610	140	TON	ASPHALT CONC INTERMEDIATE COURSE, TYPE I19.0B	4905000000-N	1253	9	EA	SNOWFLOWABLE PAVEMENT MARKERS					
1525000000-E	610	350	TON	ASPHALT CONC SURFACE COURSE, TYPE SF9.5A	6000000000-E	1605	685	LF	TEMPORARY SILT FENCE					
1560000000-E	620	40	TON	ASPHALT BINDER FOR PLANT MIX, GRADE PG 64-22	6006000000-E	1610	75	TON	STONE FOR EROSION CONTROL, CLASS A					
2000000000-N	806	5	EA	RIGHT OF WAY MARKERS	6009000000-E	1610	115	TON	STONE FOR EROSION CONTROL, CLASS B					
2286000000-N	840	2	EA	MASONRY DRAINAGE STRUCTURES	6012000000-E	1610	35	TON	SEDIMENT CONTROL STONE					
2365000000-N	840	1	EA	FRAME WITH TWO GRATES, STD 840.22	6015000000-E	1615	1	ACR	TEMPORARY MULCHING					
2367000000-N	840	1	EA	FRAME WITH TWO GRATES, STD 840.29	6018000000-E	1620	50	LB	SEED FOR TEMPORARY SEEDING					
2556000000-E	846	38	LF	SHOULDER BERM GUTTER	6021000000-E	1620	0.25	TON	FERTILIZER FOR TEMPORARY SEED- ING					
3030000000-E	862	362.5	LF	STEEL BM GUARDRAIL	6029000000-E	SP	200	LF	SAFETY FENCE					
3045000000-E	862	50	LF	STEEL BM GUARDRAIL, SHOP CURVED	6030000000-E	1630	315	CY	SILT EXCAVATION					

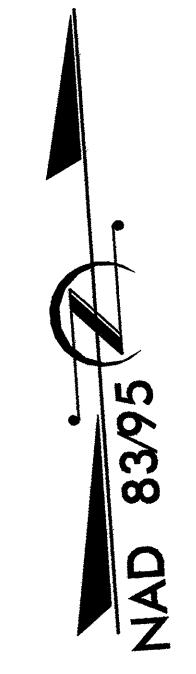
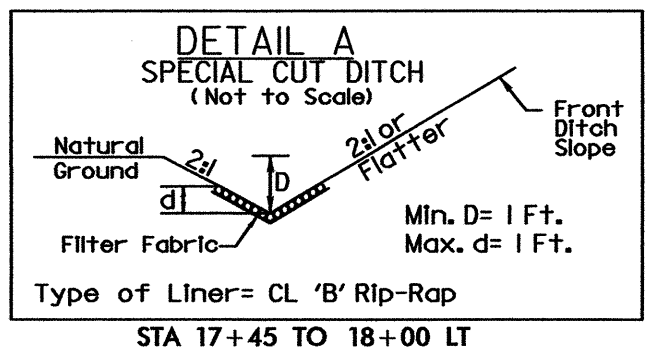

-L-
 PI Sta 19+17.42
 $\Delta = 53' 40'' 12.6'' (RT)$
 $D = 16' 51'' 06.1''$
 $L = 318.49'$
 $T = 172.01'$
 $*R = 340.00'$
 $SE = 0.00 (MATCH EXISTING)$

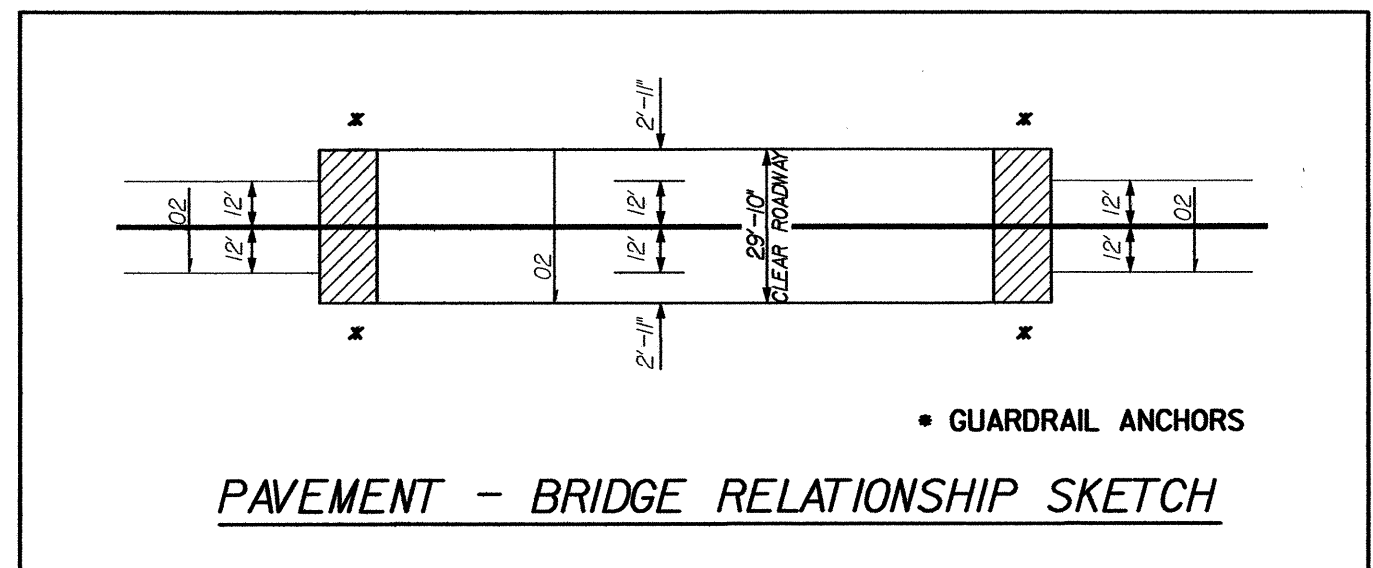
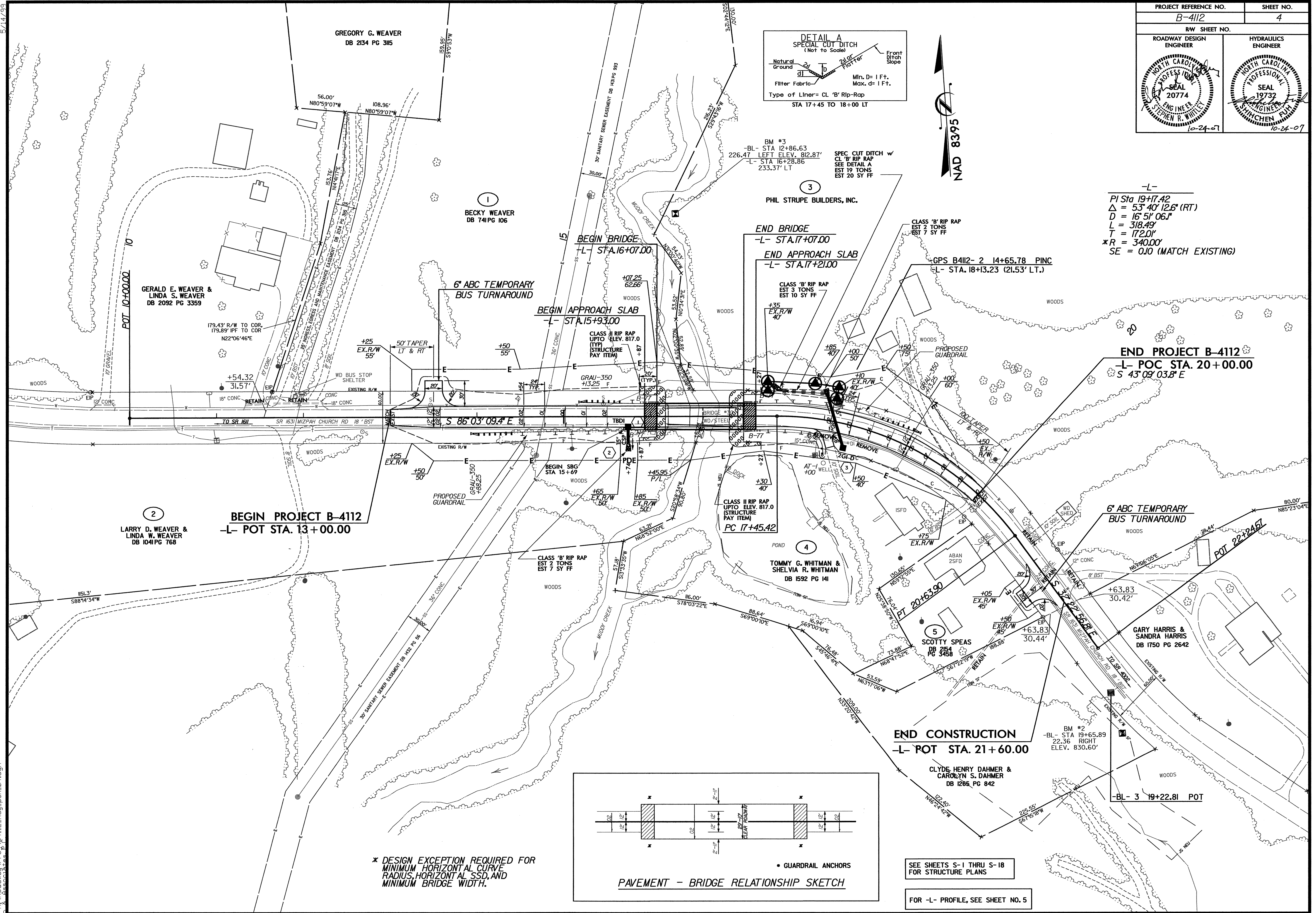

* DESIGN EXCEPTION REQUIRED FOR MINIMUM HORIZONTAL CURVE RADIUS, HORIZONTAL SSD, AND MINIMUM BRIDGE WIDTH.

SEE SHEETS S-1 THRU S-18 FOR STRUCTURE PLANS

FOR -L- PROFILE, SEE SHEET NO. 5

5/14/99
 10/24/2007
 R:\Roadway\Projects\B4112.Rdy_psh_04.dgn

5/14/99

B.M.*3 EL = 812.87'
RR SPIKE IN 1" ASH
226.47' LT OF -BL- STA 12+86.63
233.37' LT OF -L- STA 16+28.86

KO & ASSOCIATES, P.C.
Consulting Engineers
1011 SCHAUB DR., SUITE 202 RALEIGH, N.C. 27606
(919) 881-6066

PROJECT REFERENCE NO. B-4112	SHEET NO. 5
ROADWAY DESIGN ENGINEER	HYDRAULICS ENGINEER

BRIDGE HYDRAULIC DATA

DESIGN DISCHARGE = 3170 CFS
 DESIGN FREQUENCY = 25 YRS
 DESIGN HW ELEVATION = 815.5 FT
 BASE DISCHARGE = 4790 CFS
 BASE FREQUENCY = 100 YRS
 BASE HW ELEVATION = 817.3 FT
 OVERTOPPING DISCHARGE = 5850 CFS
 OVERTOPPING FREQUENCY = 200 YRS
 OVERTOPPING ELEVATION = 818.4 FT

DATE OF SURVEY = 4-22-04
 W.S.ELEVATION AT DATE OF SURVEY = 804.4 FT

-L-
FOR PLAN, SEE SHEET NO. 4

PI = 19+25.00
EL = 835.50'
VC = 150'
* K = 28
DS = 35 MPH

PI = 15+80.00
EL = 813.69'
VC = 540'
* K = 65
DS = 40 MPH

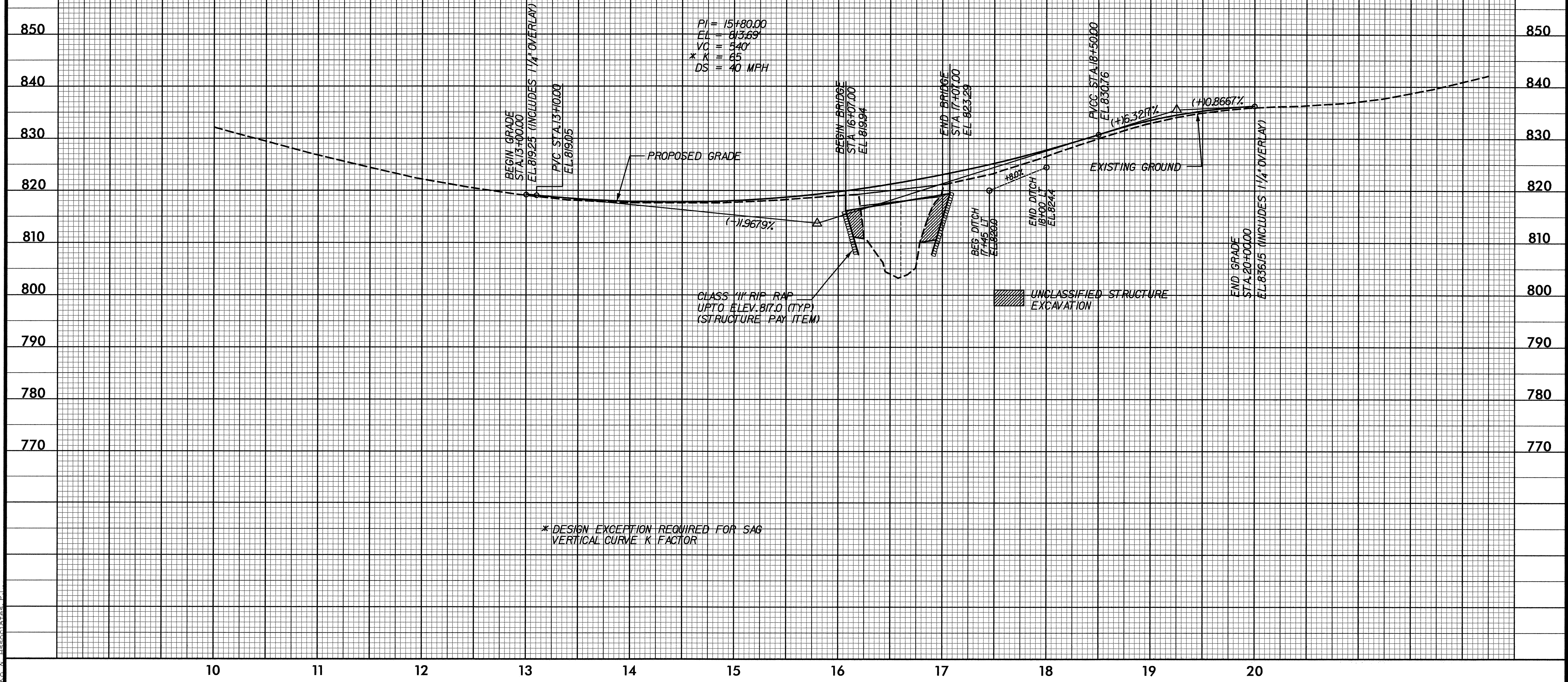

* DESIGN EXCEPTION REQUIRED FOR SAG VERTICAL CURVE K FACTOR

02/23/2007 1:00:00 PM C:\Projects\B4112_Rdy.p1_05.dgn