

09/08/09

See Sheet 1-A For Index of Sheets
See Sheet 1-B For Conventional Symbols

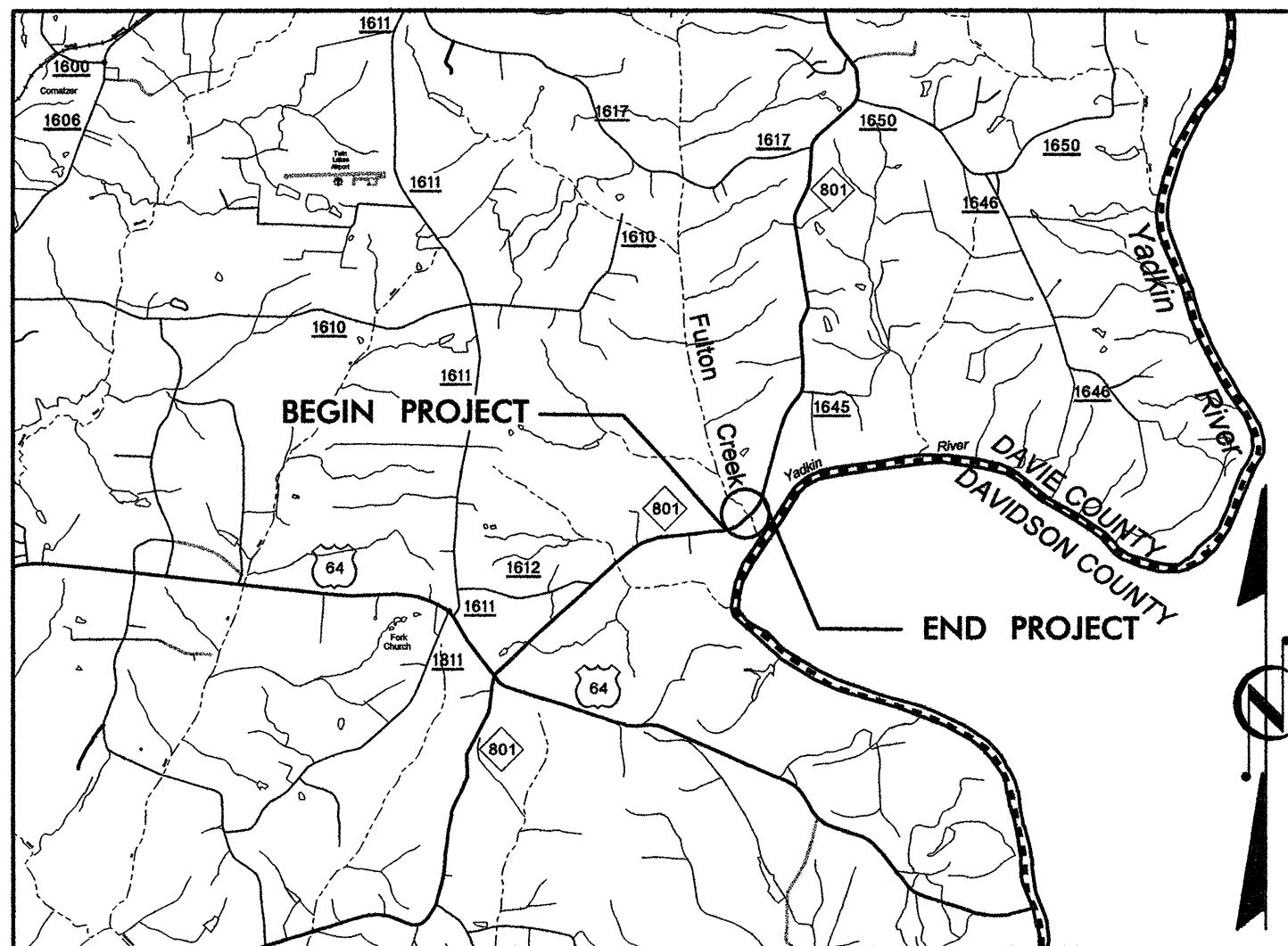

VICINITY MAP

STATE OF NORTH CAROLINA
DIVISION OF HIGHWAYS

DAVIE COUNTY

**LOCATION: BRIDGE NO. 21 OVER FULTON CREEK
ON NC 801.**

**TYPE OF WORK: GRADING, DRAINAGE, PAVING
& STRUCTURE**

STATE	STATE PROJECT REFERENCE NO.	SHEET NO.	TOTAL SHEETS
N.C.	B-4104	1	
WBS NO.	F.A.PROJ.NO.	DESCRIPTION	
33460.1.1	BRSTP-801(5)	P.E.	
33460.2.1	BRSTP-801(5)	R /W & UTIL.	
33460.3.1	BRSTP-801(5)	CONST	

TIP PROJECT: B-4104

CONTRACT: C201758

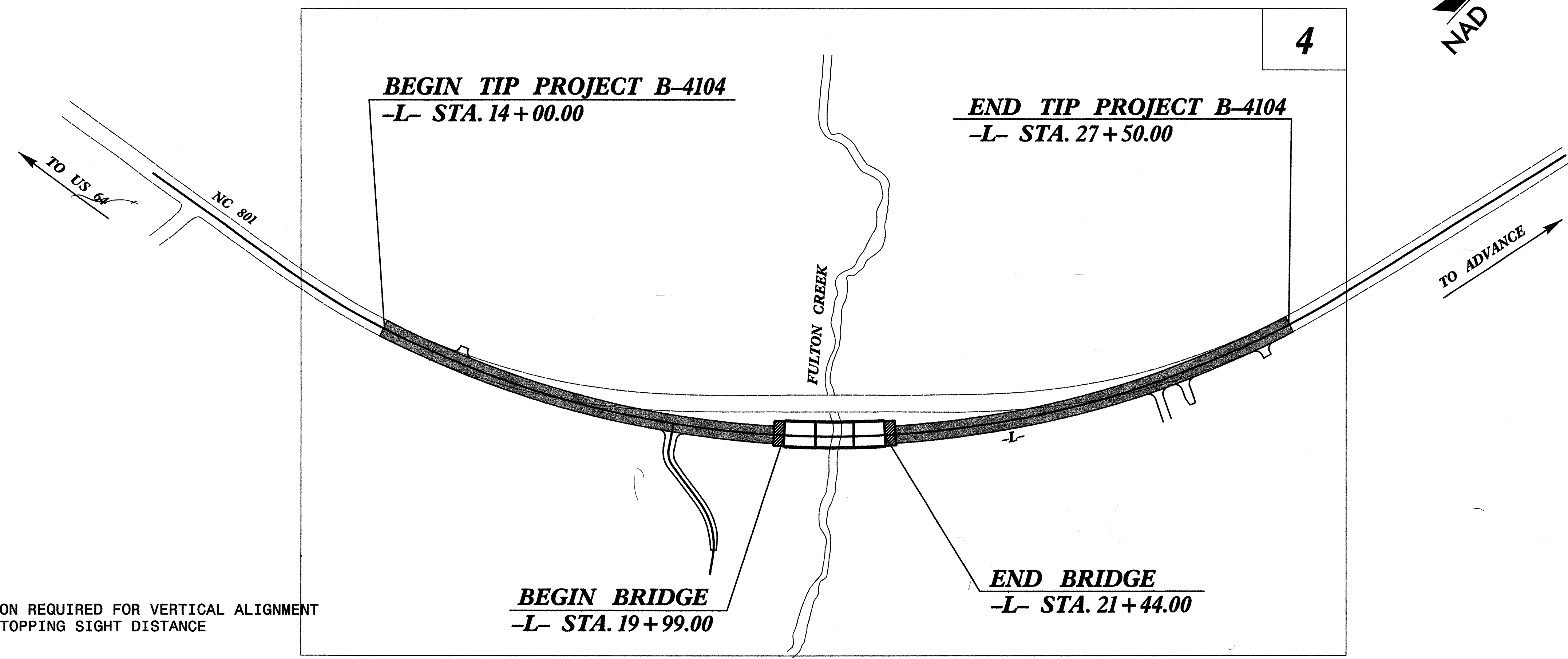
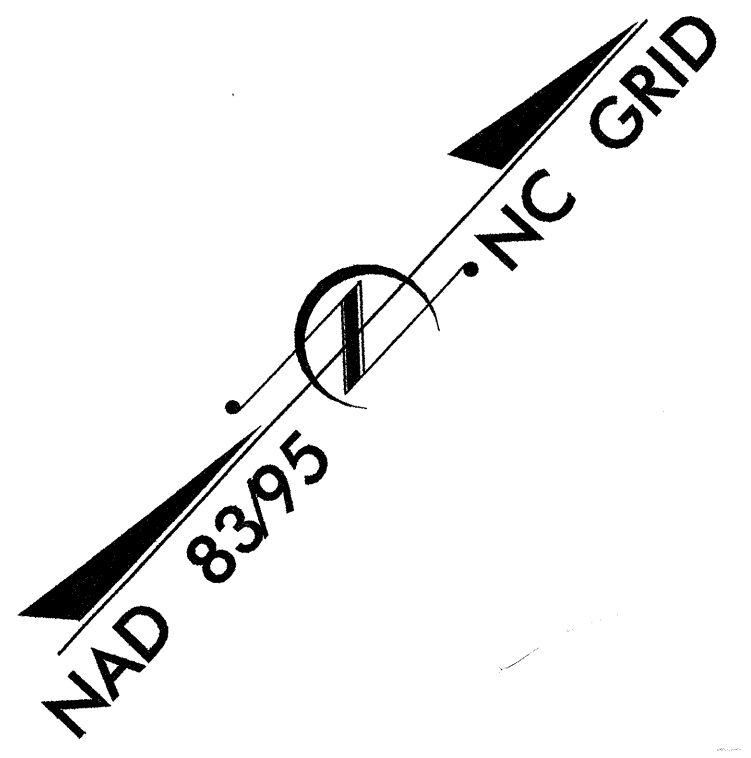

** DESIGN EXCEPTION REQUIRED FOR VERTICAL ALIGNMENT
& HORIZONTAL STOPPING SIGHT DISTANCE

NCDOT CONTACT: CATHY HOUSER, P.E.
ROADWAY DESIGN - ENGINEERING COORDINATION

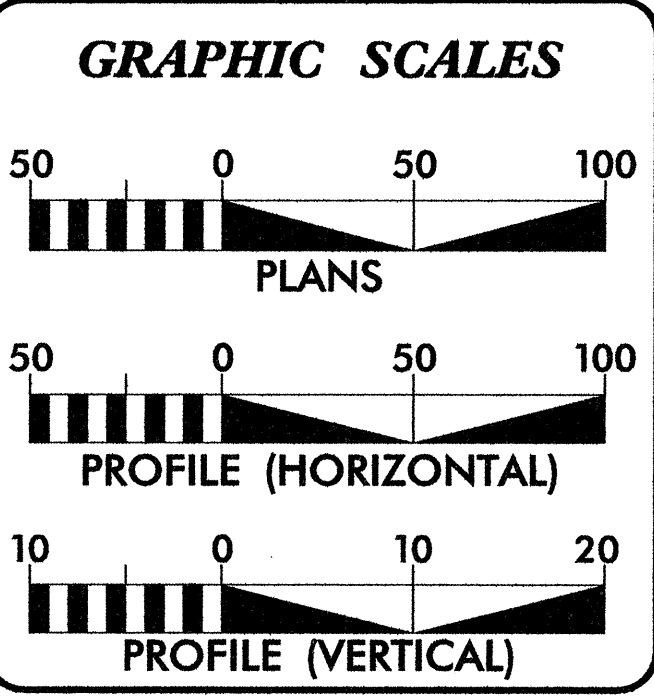

DESIGN DATA
(RURAL MAJOR COLLECTOR)

ADT 2008 =	3,270
ADT 2028 =	5,070
DHV =	10 %
D =	65 %
T =	4 % *
** V =	60 MPH
* TTST 1% DUAL 3%	

PROJECT LENGTH

LENGTH ROADWAY TIP PROJECT B-4104	=	0.229 MI.
LENGTH STRUCTURES TIP PROJECT B-4104	=	0.027 MI.
TOTAL LENGTH OF TIP PROJECT B-4104	=	0.256 MI.

Prepared In the Office of:
KO & ASSOCIATES, P.C.
Consulting Engineers
1011 Schaub Dr., Suite 202, Raleigh NC 27606
(919) 851-6066

2006 STANDARD SPECIFICATIONS

RIGHT OF WAY DATE:
AUGUST 18, 2006

LETTING DATE:
JANUARY 15, 2008

DAVID C. WALLER, PE
PROJECT ENGINEER

BRIAN A. WILES, PE
PROJECT DESIGN ENGINEER

HYDRAULICS ENGINEER

W. Herbert Turner
SIGNATURE: _____ 9-14-07

ROADWAY DESIGN ENGINEER

Del Waller
SIGNATURE: _____ 9-17-07

Professional Engineer seals for W. Herbert Turner and David C. Waller.

DIVISION OF HIGHWAYS
STATE OF NORTH CAROLINA

cut miller
SIGNATURE: _____ P.E.

STATE HIGHWAY DESIGN ENGINEER

9/13/2007
R:\Roadway\Proj\B4104_rdy_tsh.dgn
Ko & Associates, P.C.

8/17/99

INDEX OF SHEETS

SHEET NUMBER	DESCRIPTION
1	Title Sheet
1-A	Index of Sheets, General Notes, List of Standard Drawings
1-B	Conventional Symbols
1-C	Survey Control Sheet
1-D	Centerline Coordinate List
2	Typical Sections and Pavement Schedule
2-A	Anchor for Frames Detail
3	Summary of Quantities
3-A	Earthwork Summary Sheet
3-B	Drainage Summary Sheet and Guardrail Summary Sheet
3-C	Pavement Removal Summary Sheet
4	Plan Sheet
5	Profile Sheet
TCP-1 thru TCP-8	Traffic Control Plans
PM-1	Pavement Marking Plans
EC-1 thru EC-5	Erosion Control Plans
RF-1	Reforestation Plan
UO-1 thru UO-2	Utility by Others Plans
X-1	Cross-Section Summary Sheet
X-2 thru X-11	Cross-Sections
S-1 thru S-32	Structure Plans

GENERAL NOTES:

GENERAL NOTES: 2006 SPECIFICATIONS
EFFECTIVE: 07-18-06
REVISED: 07-18-06

**GRADE LINE:
GRADING AND SURFACING:**

THE GRADE LINES SHOWN DENOTE THE FINISHED ELEVATION OF THE PROPOSED SURFACING AT GRADE POINTS SHOWN ON THE TYPICAL SECTIONS. GRADE LINES MAY BE ADJUSTED AT THEIR BEGINNING AND ENDING AND AT STRUCTURES AS DIRECTED BY THE ENGINEER IN ORDER TO SECURE A PROPER TIE-IN.

CLEARING:

CLEARING ON THIS PROJECT SHALL BE PERFORMED TO THE LIMITS ESTABLISHED BY METHOD III.

SUPERELEVATION:

ALL CURVES ON THIS PROJECT SHALL BE SUPERELEVATED IN ACCORDANCE WITH STD. NO. 225.04 USING THE RATE OF SUPERELEVATION AND RUNOFF SHOWN ON THE PLANS. SUPERELEVATION IS TO BE REVOLVED ABOUT THE GRADE POINTS SHOWN ON THE TYPICAL SECTIONS.

SHOULDER CONSTRUCTION:

ASPHALT, EARTH, AND CONCRETE SHOULDER CONSTRUCTION ON THE HIGH SIDE OF SUPERELEVATED CURVES SHALL BE IN ACCORDANCE WITH STD. NO. 560.01.

SIDE ROADS:

THE CONTRACTOR WILL BE REQUIRED TO DO ALL NECESSARY WORK TO PROVIDE SUITABLE CONNECTIONS WITH ALL ROADS, STREETS, AND DRIVES ENTERING THIS PROJECT. THIS WORK WILL BE PAID FOR AT THE CONTRACT UNIT PRICE FOR THE PARTICULAR ITEMS INVOLVED.

GUARDRAIL:

THE GUARDRAIL LOCATIONS SHOWN ON THE PLANS MAY BE ADJUSTED DURING CONSTRUCTION AS DIRECTED BY THE ENGINEER. THE CONTRACTOR SHOULD CONSULT WITH THE ENGINEER PRIOR TO ORDERING GUARDRAIL MATERIAL.

TEMPORARY SHORING:

SHORING REQUIRED FOR THE MAINTENANCE OF TRAFFIC WILL BE PAID FOR AS "EXTRA WORK" IN ACCORDANCE WITH SECTION 104-7.

SUBSURFACE PLANS:

NO SUBSURFACE PLANS ARE AVAILABLE ON THIS PROJECT. THE CONTRACTOR SHOULD MAKE HIS OWN INVESTIGATION AS TO THE SUBSURFACE CONDITIONS.

END BENTS:

THE ENGINEER SHALL CHECK THE STRUCTURE END BENT PLANS, DETAILS, AND CROSS-SECTION PRIOR TO SETTING OF THE SLOPE STAKES FOR THE EMBANKMENT OR EXCAVATION APPROACHING A BRIDGE.

UTILITIES:

UTILITY OWNERS ON THIS PROJECT ARE DUKE ENERGY AND YADKIN VALLEY TMC.

ANY RELOCATION OF EXISTING UTILITIES WILL BE ACCOMPLISHED BY OTHERS.

RIGHT-OF-WAY MARKERS:

ALL RIGHT-OF-WAY MARKERS ON THIS PROJECT SHALL BE PLACED BY CONTRACT.

2006 ROADWAY STANDARD DRAWINGS

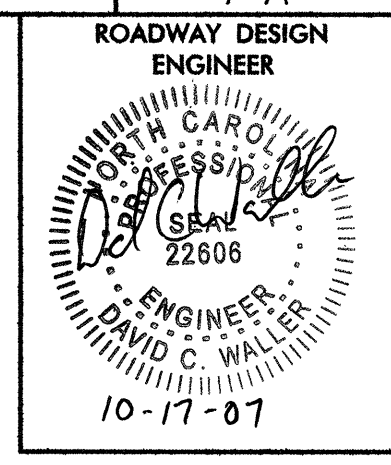

2006 ROADWAY ENGLISH STANDARD DRAWINGS

EFF. 07-18-06
REV. 01-02-07

The following Roadway Standards as appear in "Roadway Standard Drawings" Highway Design Branch - N. C. Department of Transportation - Raleigh, N. C., Dated July 18, 2006 are applicable to this project and by reference hereby are considered a part of these plans:

STD. NO.	TITLE
DIVISION 2 - EARTHWORK	
200.03	Method of Clearing - Method III
225.02	Guide for Grading Subgrade - Secondary and Local
225.04	Method of Obtaining Superelevation - Two Lane Pavement
DIVISION 3 - PIPE CULVERTS	
300.01	Method of Pipe Installation - Method 'A'
310.10	Driveway Pipe Construction
DIVISION 4 - MAJOR STRUCTURES	
422.10	Reinforced Bridge Approach Fills
DIVISION 5 - SUBGRADE, BASES AND SHOULDERS	
560.01	Method of Shoulder Construction - High Side of Superelevated Curve - Method I
DIVISION 8 - INCIDENTALS	
806.01	Concrete Right-of-Way Marker
806.02	Granite Right-of-Way Marker
840.00	Concrete Base Pad for Drainage Structures
840.18	Concrete Grated Drop Inlet Type 'B' - 12" thru 36" Pipe
840.27	Brick Grated Drop Inlet Type 'B' - 12" thru 36" Pipe
840.29	Frames and Narrow Slot Flat Grates
840.45	Precast Drainage Structure
846.01	Concrete Curb, Gutter and Curb & Gutter
846.04	Drainage Installation in Shoulder Berm Gutter
862.01	Guardrail Placement
862.02	Guardrail Installation
862.03	Structure Anchor Units
862.04	Anchoring End of Guardrail - B-77 and B-83 Anchor Units
876.01	Rip Rap in Channels
876.02	Guide for Rip Rap at Pipe Outlets
876.04	Drainage Ditches with Class 'B' Rip Rap

3/15/06











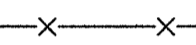

Note: Not to Scale

*S.U.E. = Subsurface Utility Engineering











STATE OF NORTH CAROLINA
DIVISION OF HIGHWAYS

CONVENTIONAL PLAN SHEET SYMBOLS











BOUNDARIES AND PROPERTY:

State Line	_____
County Line	_____
Township Line	_____
City Line	_____
Reservation Line	_____
Property Line	_____
Existing Iron Pin	_____ 
Property Corner	_____ 
Property Monument	_____ 
Parcel/Sequence Number	_____ 
Existing Fence Line	_____ 
Proposed Woven Wire Fence	_____ 
Proposed Chain Link Fence	_____ 
Proposed Barbed Wire Fence	_____ 
Existing Wetland Boundary	_____ 
Proposed Wetland Boundary	_____ 
Existing Endangered Animal Boundary	_____ 
Existing Endangered Plant Boundary	_____ 





BUILDINGS AND OTHER CULTURE:

Gas Pump Vent or U/G Tank Cap	_____ 
Sign	_____ 
Well	_____ 
Small Mine	_____ 
Foundation	_____ 
Area Outline	_____ 
Cemetery	_____ 
Building	_____ 
School	_____ 
Church	_____ 
Dam	_____ 



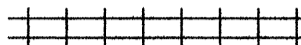









HYDROLOGY:

Stream or Body of Water	_____
Hydro, Pool or Reservoir	_____ 
Jurisdictional Stream	_____ 
Buffer Zone 1	_____ 
Buffer Zone 2	_____ 
Flow Arrow	_____ 
Disappearing Stream	_____ 
Spring	_____ 
Wetland	_____ 
Proposed Lateral, Tail, Head Ditch	_____ 
False Sump	_____ 













RAILROADS:

Standard Gauge	_____ 
RR Signal Milepost	_____ 
Switch	_____ 
RR Abandoned	_____ 
RR Dismantled	_____ 







RIGHT OF WAY:

Baseline Control Point	_____ 
Existing Right of Way Marker	_____ 
Existing Right of Way Line	_____ 
Proposed Right of Way Line	_____ 
Proposed Right of Way Line with Iron Pin and Cap Marker	_____ 
Proposed Right of Way Line with Concrete or Granite Marker	_____ 
Existing Control of Access	_____ 
Proposed Control of Access	_____ 
Existing Easement Line	_____ 
Proposed Temporary Construction Easement	_____ 
Proposed Temporary Drainage Easement	_____ 
Proposed Permanent Drainage Easement	_____ 
Proposed Permanent Utility Easement	_____ 





ROADS AND RELATED FEATURES:

Existing Edge of Pavement	_____ 
Existing Curb	_____ 
Proposed Slope Stakes Cut	_____ 
Proposed Slope Stakes Fill	_____ 
Proposed Wheel Chair Ramp	_____ 
Proposed Wheel Chair Ramp Curb Cut	_____ 
Curb Cut for Future Wheel Chair Ramp	_____ 
Existing Metal Guardrail	_____ 
Proposed Guardrail	_____ 
Existing Cable Guiderail	_____ 
Proposed Cable Guiderail	_____ 
Equality Symbol	_____ 
Pavement Removal	_____ 



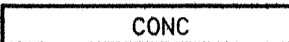
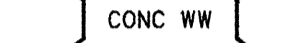
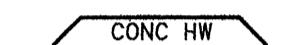
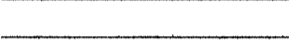
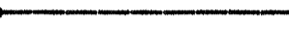
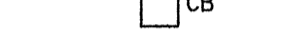





VEGETATION:

Single Tree	_____ 
Single Shrub	_____ 
Hedge	_____ 
Woods Line	_____ 
Orchard	_____ 
Vineyard	_____ 



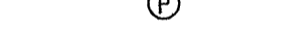
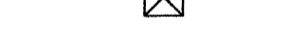
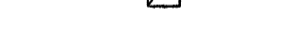





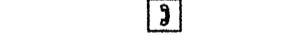
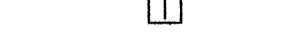

EXISTING STRUCTURES:

MAJOR:	
Bridge, Tunnel or Box Culvert	_____ 
Bridge Wing Wall, Head Wall and End Wall	_____ 
MINOR:	
Head and End Wall	_____ 
Pipe Culvert	_____ 
Footbridge	_____ 
Drainage Box: Catch Basin, DI or JB	_____ 
Paved Ditch Gutter	_____ 
Storm Sewer Manhole	_____ 
Storm Sewer	_____ 

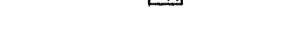



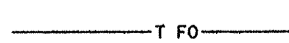
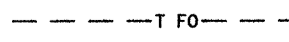

UTILITIES:

POWER:	
Existing Power Pole	_____ 
Proposed Power Pole	_____ 
Existing Joint Use Pole	_____ 
Proposed Joint Use Pole	_____ 
Power Manhole	_____ 
Power Line Tower	_____ 
Power Transformer	_____ 
U/G Power Cable Hand Hole	_____ 
H-Frame Pole	_____ 
Recorded U/G Power Line	_____ 
Designated U/G Power Line (S.U.E.*)	_____ 









TELEPHONE:

Existing Telephone Pole	_____ 
Proposed Telephone Pole	_____ 
Telephone Manhole	_____ 
Telephone Booth	_____ 
Telephone Pedestal	_____ 
Telephone Cell Tower	_____ 
U/G Telephone Cable Hand Hole	_____ 
Recorded U/G Telephone Cable	_____ 
Designated U/G Telephone Cable (S.U.E.*)	_____ 
Recorded U/G Telephone Conduit	_____ 
Designated U/G Telephone Conduit (S.U.E.*)	_____ 
Recorded U/G Fiber Optics Cable	_____ 
Designated U/G Fiber Optics Cable (S.U.E.*)	_____ 





WATER:

Water Manhole	_____ 
Water Meter	_____ 
Water Valve	_____ 
Water Hydrant	_____ 
Recorded U/G Water Line	_____ 
Designated U/G Water Line (S.U.E.*)	_____ 
Above Ground Water Line	_____ 







TV:

TV Satellite Dish	_____ 
TV Pedestal	_____ 
TV Tower	_____ 
U/G TV Cable Hand Hole	_____ 
Recorded U/G TV Cable	_____ 
Designated U/G TV Cable (S.U.E.*)	_____ 
Recorded U/G Fiber Optic Cable	_____ 
Designated U/G Fiber Optic Cable (S.U.E.*)	_____ 











GAS:

Gas Valve	_____ 
Gas Meter	_____ 
Recorded U/G Gas Line	_____ 
Designated U/G Gas Line (S.U.E.*)	_____ 
Above Ground Gas Line	_____ 

SANITARY SEWER:

Sanitary Sewer Manhole	_____ 
Sanitary Sewer Cleanout	_____ 
U/G Sanitary Sewer Line	_____ 
Above Ground Sanitary Sewer	_____ 
Recorded SS Forced Main Line	_____ 
Designated SS Forced Main Line (S.U.E.*)	_____ 

MISCELLANEOUS:

Utility Pole	_____ 
Utility Pole with Base	_____ 
Utility Located Object	_____ 
Utility Traffic Signal Box	_____ 
Utility Unknown U/G Line	_____ 
U/G Tank; Water, Gas, Oil	_____ 
A/G Tank; Water, Gas, Oil	_____ 
U/G Test Hole (S.U.E.*)	_____ 
Abandoned According to Utility Records	_____ 
End of Information	_____ 

6/2/99

SURVEY CONTROL SHEET B4104

PROJECT REFERENCE NO.	SHEET NO.
B4104	1C
Location and Surveys	

NCDOT GPS MONUMENT B4104-1
 N : 780630.208
 E : 1578961.347

NCDOT GPS MONUMENT B4104-2
 N : 780672.754
 E : 1579863.561

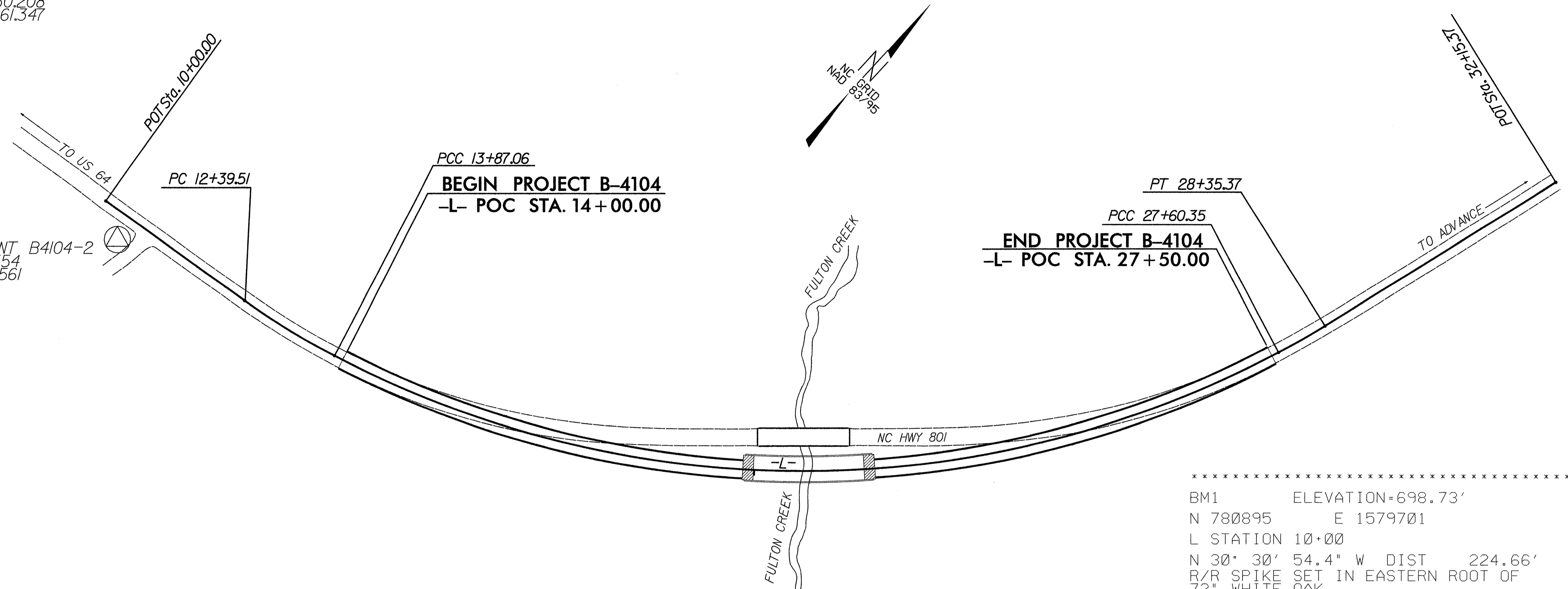

 BM1 ELEVATION=698.73'
 N 780895 E 1579701
 L STATION 10+00
 N 30° 30' 54.4" W DIST 224.66'
 R/R SPIKE SET IN EASTERN ROOT OF
 72" WHITE OAK.

 BM2 ELEVATION=795.69'
 N 781632 E 1581065
 L STATION 27+00 86' LEFT
 R/R SPIKE SET IN SOUTHERN ROOT OF
 24" RED OAK.

BL	POINT	DESC.	NORTH	EAST	ELEVATION	L STATION	OFFSET
	BL1	B4104-1	780630.2080	1578961.3470	718.70	OUTSIDE PROJECT LIMITS	
	BL2	B4104-2	780672.7540	1579863.5610	706.54	10+45.01	34.63 RT
	BL3	BL-3	780798.4940	1580359.9890	695.47	15+53.34	13.96 RT
	BL4	BL-4	781057.3910	1580717.6830	676.31	19+96.74	25.43 LT
	BL5	BL-5	781451.5490	1581101.5280	700.67	25+48.42	24.27 RT
	BL6	BL-6	782266.6470	1581312.1980	720.90	OUTSIDE PROJECT LIMITS	

DATUM DESCRIPTION

THE LOCALIZED COORDINATE SYSTEM DEVELOPED FOR THIS PROJECT IS BASED ON THE STATE PLANE COORDINATES ESTABLISHED BY NCDOT FOR MONUMENT "B4104-1"
 WITH NAD 1983/95 STATE PLANE GRID COORDINATES OF
 NORTHING: 780630.208(ft) EASTING: 1578961.347(ft)
 THE AVERAGE COMBINED GRID FACTOR USED ON THIS PROJECT (GROUND TO GRID) IS: 0.99990457
 THE N.C. LAMBERT GRID BEARING AND LOCALIZED HORIZONTAL GROUND DISTANCE FROM "B4104-1" TO -L- STATION 14+00.00 IS
 N83°58'34.7"E 1255.31'
 ALL LINEAR DIMENSIONS ARE LOCALIZED HORIZONTAL DISTANCES
 VERTICAL DATUM USED IS NAVD 88

NOTES:

1. THE CONTROL DATA FOR THIS PROJECT CAN BE FOUND ELECTRONICALLY BY SELECTING PROJECT CONTROL DATA AT:
[HTTP://WWW.NC.DOT.ORG/PRECONSTRUCT/HIGHWAY/LOCATION/PROJECT/](http://www.nc.dot.org/preconstruct/highway/location/project/)

THE FILES TO BE FOUND ARE AS FOLLOWS:
 TIPB4104_LS_CONTROL_051011.TXT

SITE CALIBRATION INFORMATION HAS NOT BEEN PROVIDED FOR THIS PROJECT. IF FURTHER INFORMATION IS NEEDED, PLEASE CONTACT THE LOCATION AND SURVEYS UNIT.

INDICATES GEODETIC CONTROL MONUMENTS USED OR SET FOR HORIZONTAL PROJECT CONTROL BY THE NCDOT LOCATION AND SURVEYS UNIT.

PROJECT CONTROL ESTABLISHED USING GLOBAL POSITIONING SYSTEM.
 NETWORK ESTABLISHED FROM NGS ONLINE POSITIONING SERVICE (OPUS)
 SEE GPS CALIBRATION SHEET FOR HORIZONTAL AND VERTICAL COORDINATE VALUES.

NOTE: DRAWING NOT TO SCALE

9/13/2007
 R:\Roadway\Proj\B4104_1s_1c_051011.dgn
 P.C. & Associates, P.A.

TRANSITION FROM EXISTING TO T.S. NO. 1
 -L- STA. 14+00.00 TO 14+50.00

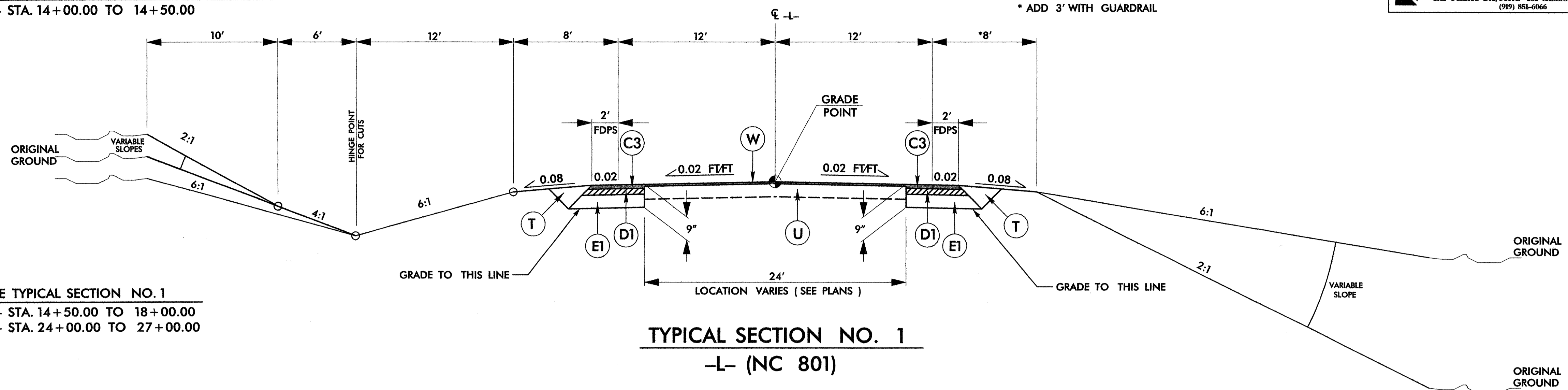

USE TYPICAL SECTION NO. 1
 -L- STA. 14+50.00 TO 18+00.00
 -L- STA. 24+00.00 TO 27+00.00

TRANSITION FROM T.S. NO. 1 TO EXISTING
 -L- STA. 27+00.00 TO 27+50.00

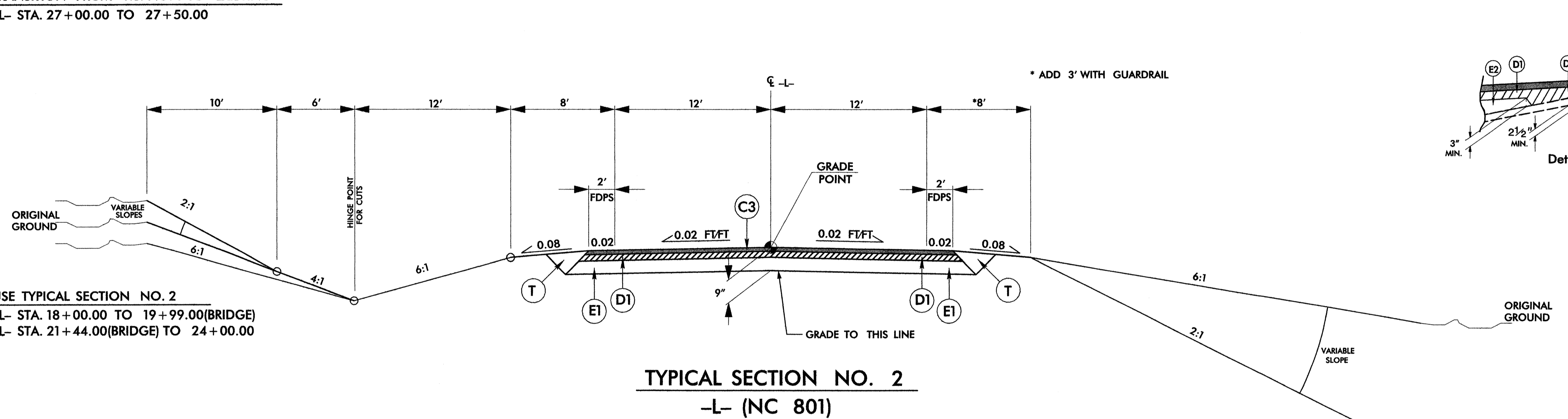

USE TYPICAL SECTION NO. 2
 -L- STA. 18+00.00 TO 19+99.00 (BRIDGE)
 -L- STA. 21+44.00 (BRIDGE) TO 24+00.00

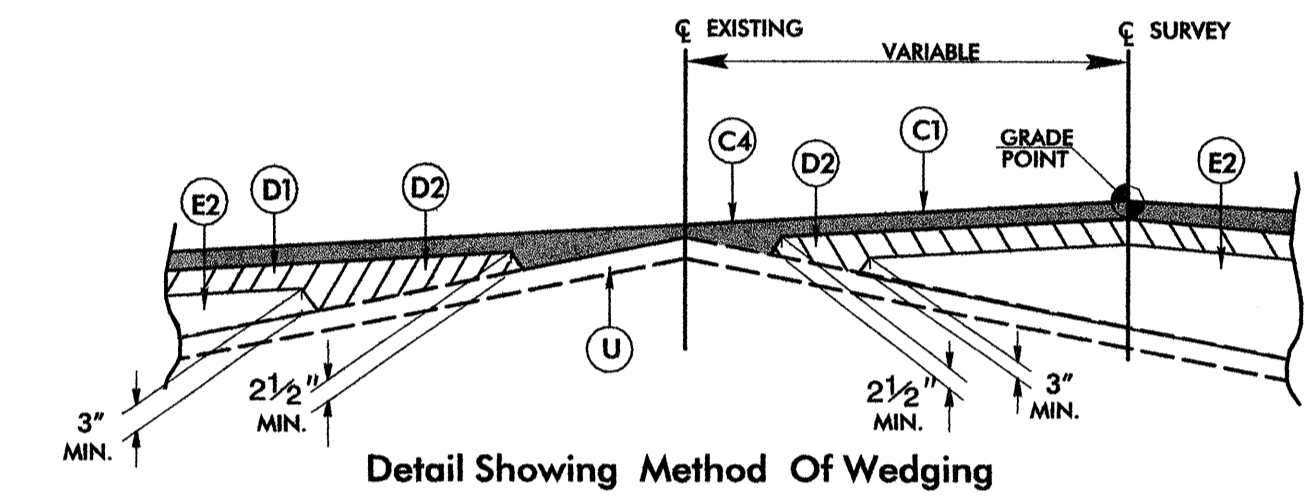

PAVEMENT SCHEDULE			
C1	PROP. APPROX. 1 1/4" ASPHALT CONCRETE SURFACE COURSE, TYPE SF9.5A, AT AN AVERAGE RATE OF 138 LBS. PER SQ. YD.	E1	PROP. APPROX. 4" ASPHALT CONCRETE BASE COURSE, TYPE B25.0B, AT AN AVERAGE RATE OF 456 LBS. PER SQ. YD.
C2	PROP. APPROX. 2" ASPHALT CONCRETE SURFACE COURSE, TYPE SF9.5A, AT AN AVERAGE RATE OF 110 LBS. PER SQ. YD. IN EACH OF TWO LAYERS.	E2	PROP. VAR. DEPTH ASPHALT CONCRETE BASE COURSE, TYPE B25.0B, AT AN AVERAGE RATE OF 114 LBS. PER SQ. YD. PER 1" DEPTH. TO BE PLACED IN LAYERS NOT LESS THAN 3" IN DEPTH OR GREATER THAN 5 1/2" IN DEPTH.
C3	PROP. APPROX. 2 1/2" ASPHALT CONCRETE SURFACE COURSE, TYPE SF9.5A, AT AN AVERAGE RATE OF 138 LBS. PER SQ. YD. IN EACH OF TWO LAYERS.	J	PROP. 8" AGGREGATE BASE COURSE
C4	PROP. VAR. DEPTH ASPHALT CONCRETE SURFACE COURSE, TYPE SF9.5A, AT AN AVERAGE RATE OF 110 LBS. PER SQ. YD. PER 1" DEPTH. TO BE PLACED IN LAYERS NOT TO EXCEED 1 1/2" IN DEPTH.	P	PRIME COAT AT THE RATE OF .35 GAL. PER SQ. YD.
D1	PROP. APPROX. 2 1/2" ASPHALT CONCRETE INTERMEDIATE COURSE, TYPE I19.0B, AT AN AVERAGE RATE OF 285 LBS. PER SQ. YD.	T	EARTH MATERIAL.
D2	PROP. VAR. DEPTH ASPHALT CONCRETE INTERMEDIATE COURSE, TYPE I19.0B, AT AN AVERAGE RATE OF 114 LBS. PER SQ. YD. PER 1" DEPTH, TO BE PLACED IN LAYERS NOT LESS THAN 2 1/2" IN DEPTH OR GREATER THAN 4" IN DEPTH.	U	EXISTING PAVEMENT.
		W	VARIABLE DEPTH ASPHALT PAVEMENT (SEE WEDGING DETAIL)

NOTE: PAVEMENT EDGE SLOPES ARE 1:1 UNLESS SHOWN OTHERWISE.

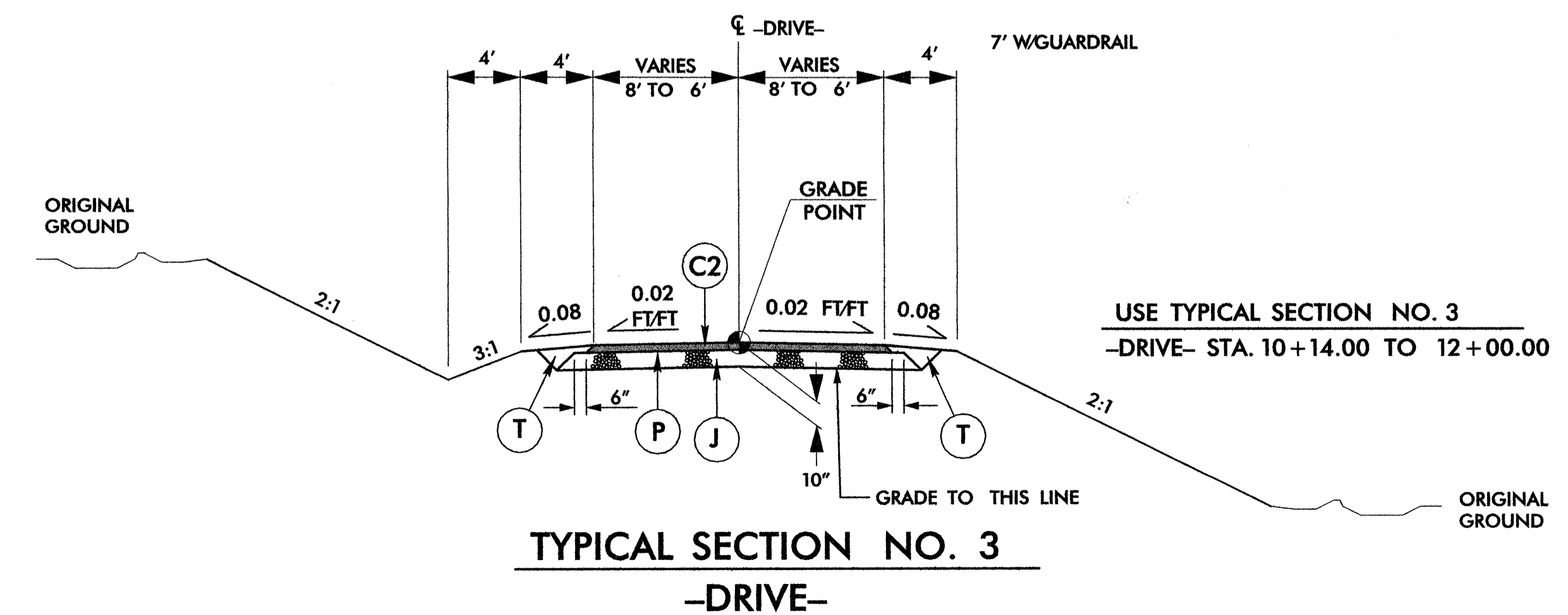

USE TYPICAL SECTION NO. 3
 -DRIVE- STA. 10+14.00 TO 12+00.00

6/27/99
 10/18/2007
 K:\pavement\p_c\104104_r.dwg_tup.dgn

STATE OF NORTH CAROLINA
DEPT. OF TRANSPORTATION
DIVISION OF HIGHWAYS
RALEIGH, N.C.

ENGLISH DETAIL DRAWING FOR
ANCHORAGE FOR FRAMES
BRICK/CONCRETE/PRECAST CONCRETE

SHEET 1 OF 1
840D25

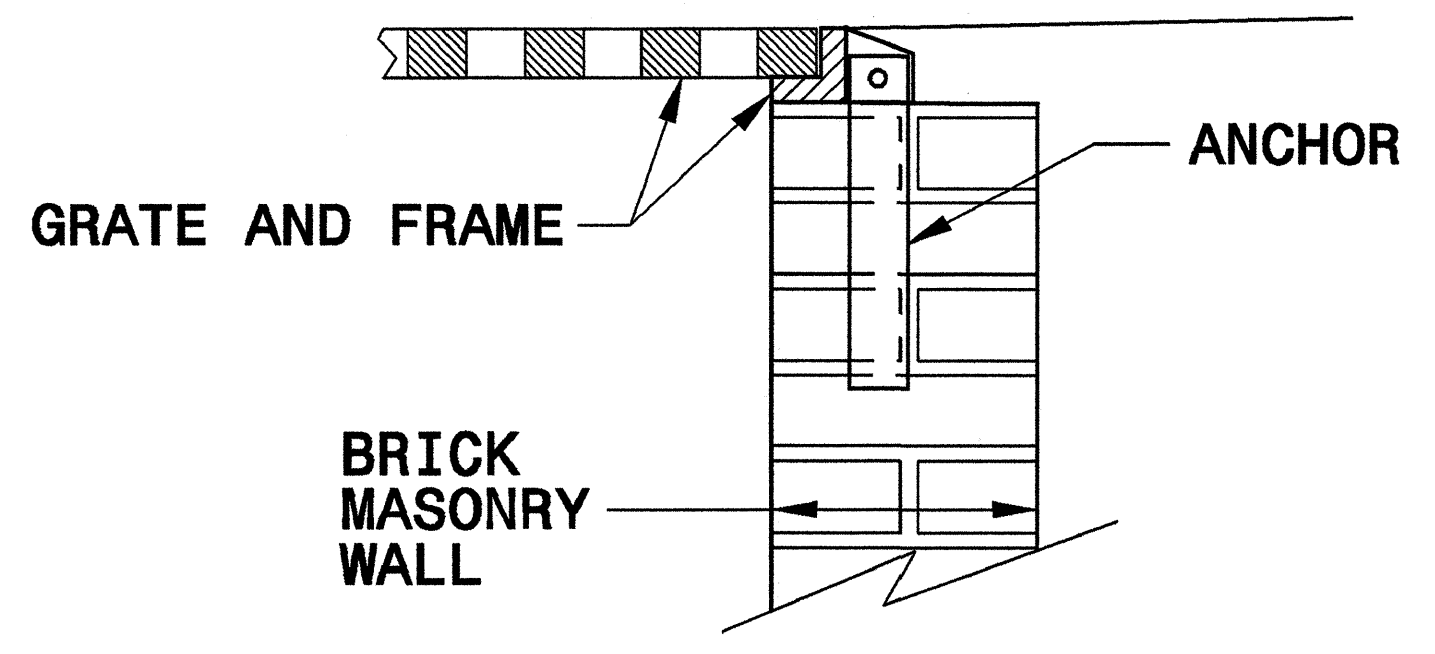

BRICK MASONRY CONSTRUCTION

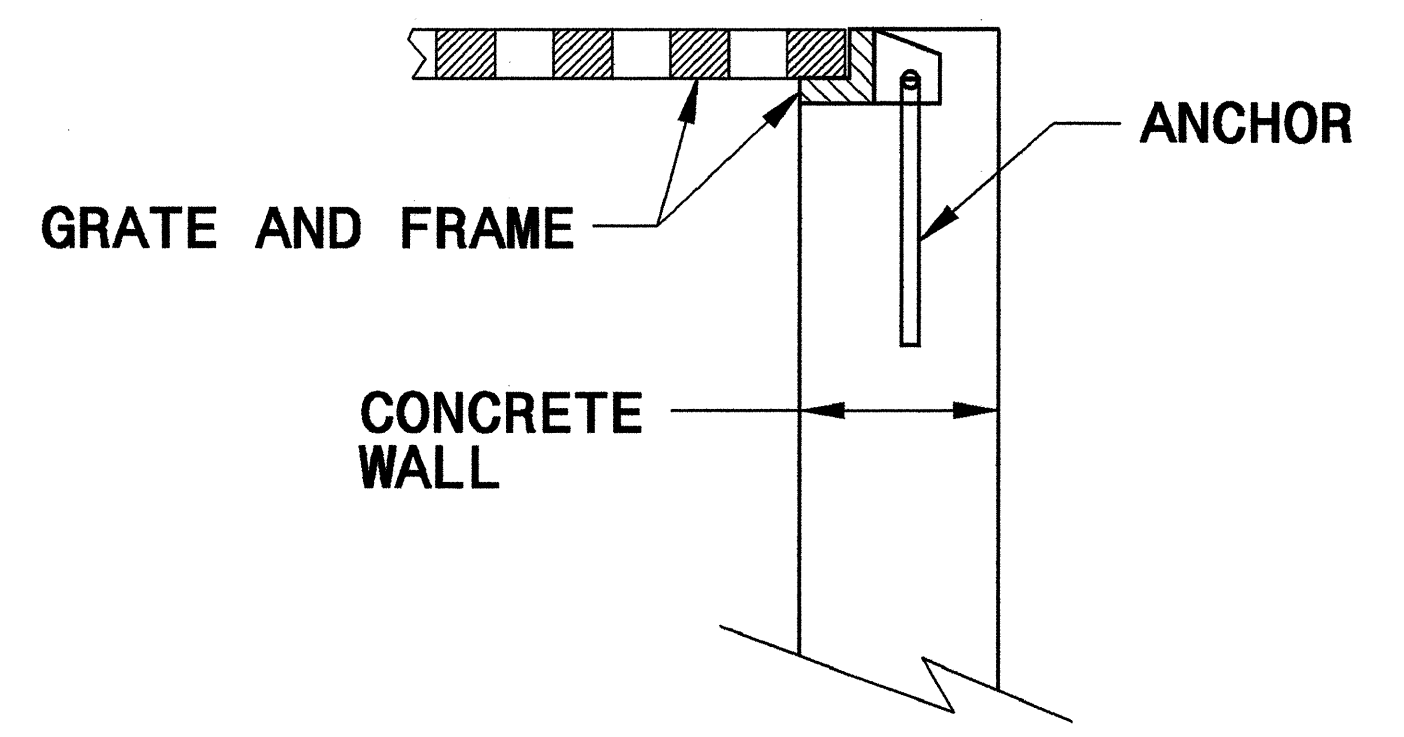

CONCRETE CONSTRUCTION

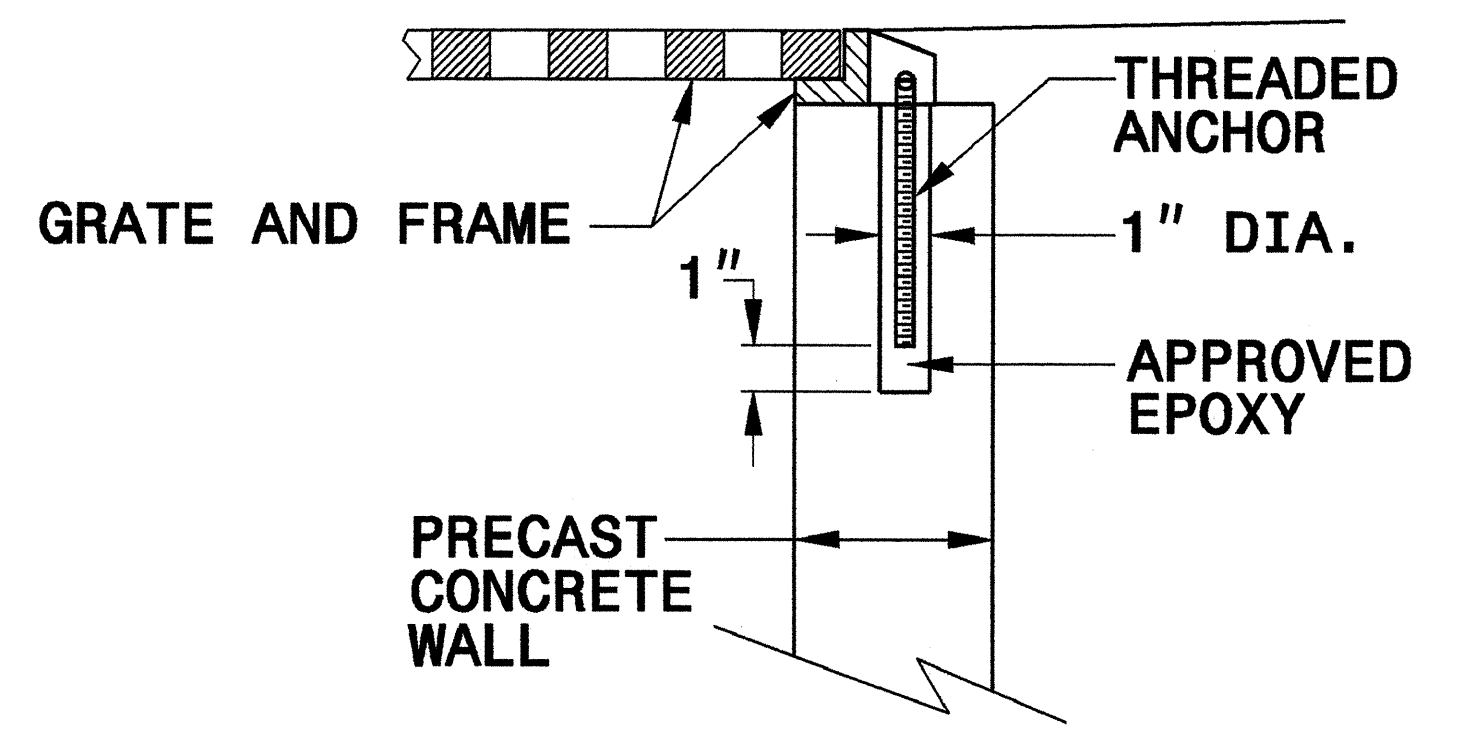

PRECAST CONCRETE CONSTRUCTION

DETAIL SHOWING ANCHORAGE OF FRAME FOR GRATED DROP INLET

NOTE:
CONSTRUCT GRATED DROP INLET TO COINCIDE WITH NORMAL OR SUPERELEVATED SHOULDER OR PAVEMENT SLOPE.

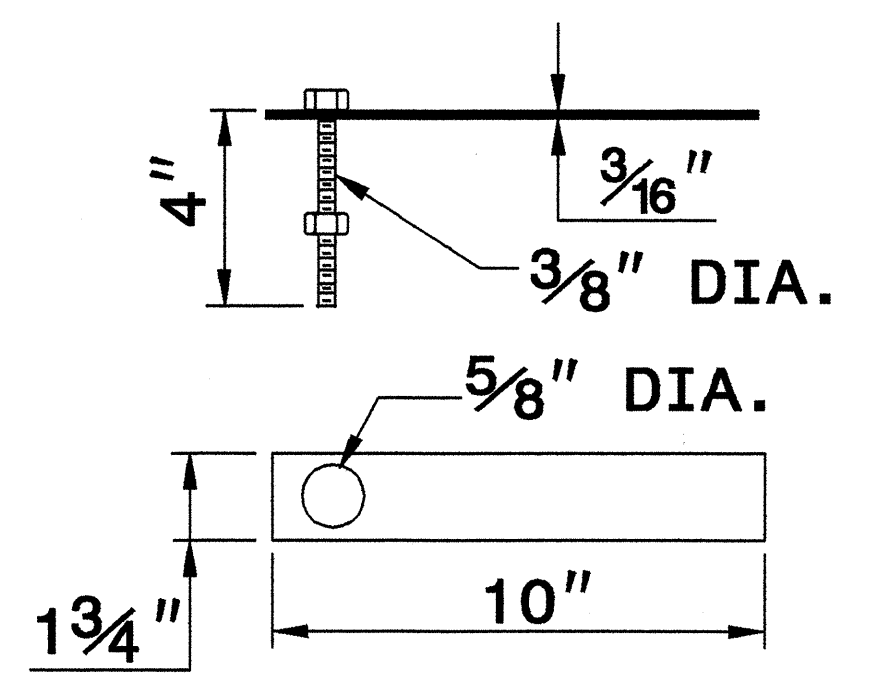

MASONRY ANCHOR
3/8" DIA. BOLT WITH PLATE

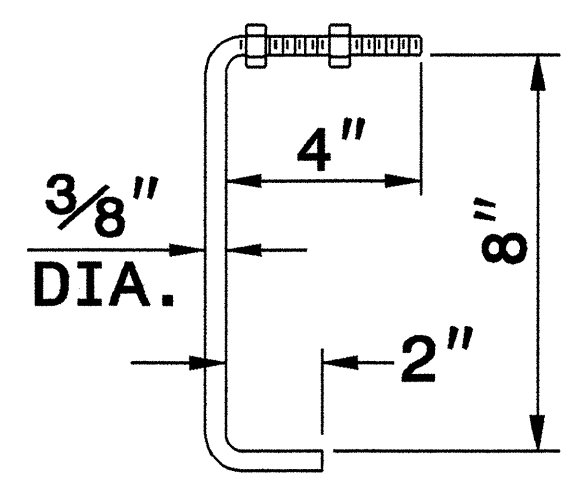

CONCRETE ANCHOR
3/8" DIA. BENT BAR

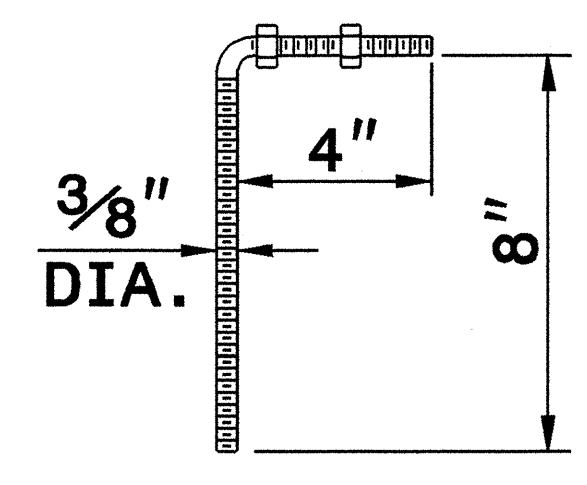

PRECAST CONCRETE ANCHOR
3/8" DIA. BENT BAR

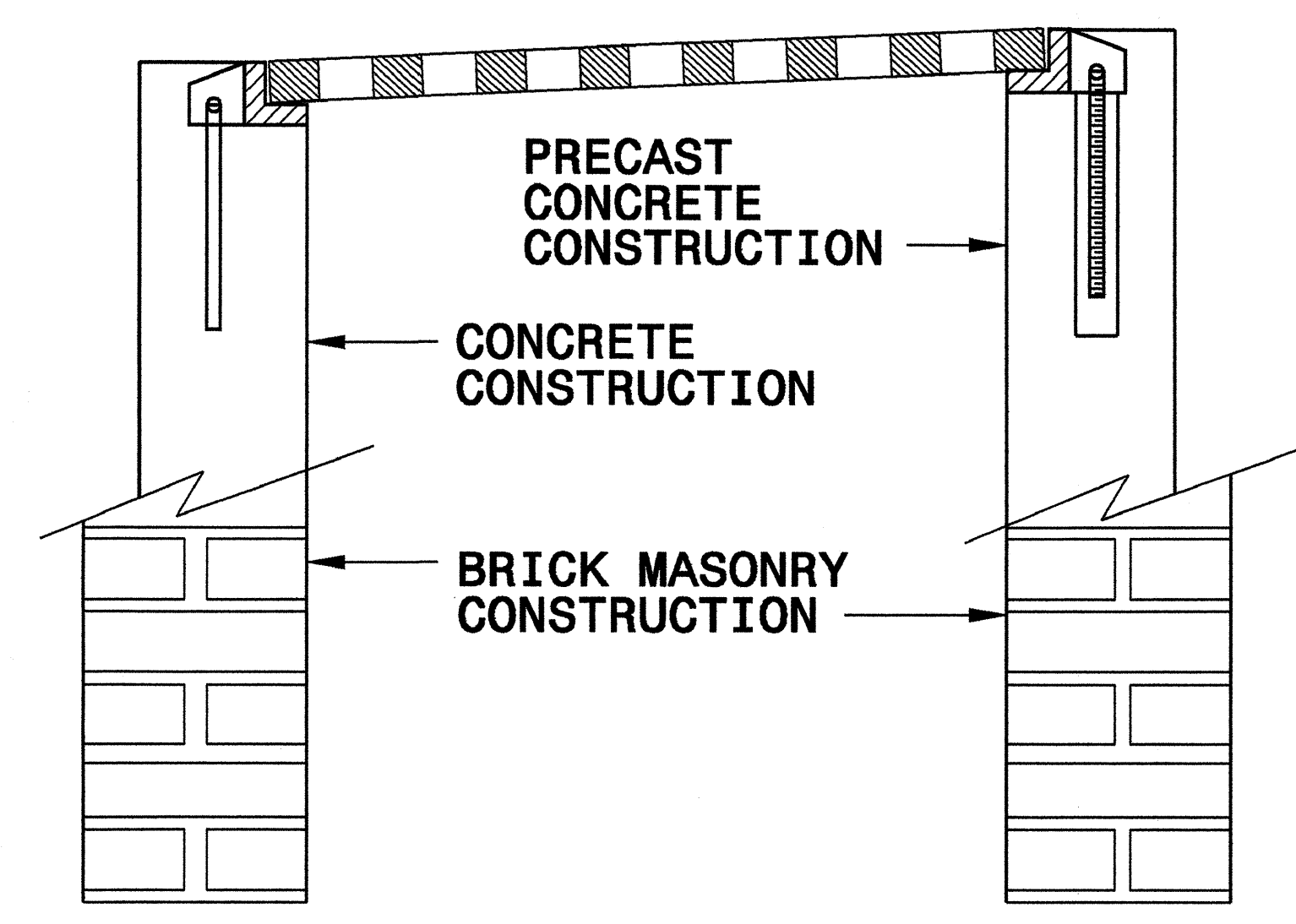

FRAME AND GRATE INSTALLATION FOR NORMAL CROWN AND SUPERELEVATED SECTIONS

STATE OF NORTH CAROLINA
DEPT. OF TRANSPORTATION
DIVISION OF HIGHWAYS
RALEIGH, N.C.

ENGLISH DETAIL DRAWING FOR
ANCHORAGE FOR FRAMES
BRICK/CONCRETE/PRECAST CONCRETE

SHEET 1 OF 1
840D25

27_SEP-2006_08:59 S:\Contractors\Special Details\encard\stds\06\stds to Special Details\840D25 Anchorage for Frames\0840d25.dgn

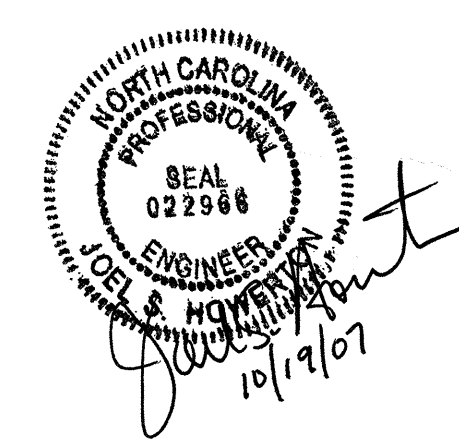

**PROJECT SERVICES UNIT
STANDARDS AND SPECIAL DESIGN**
Office 919-250-4128 FAX 919-250-4119

SEE PLATE FOR TITLE

ORIGINAL BY: 2006 STD 840.25 DATE: 07/18/06
MODIFIED BY: E.E. WARD DATE: 9/25/06
CHECKED BY: _____ DATE: _____
FILE SPEC.: _____

SUMMARY OF QUANTITIES

STATE OF NORTH CAROLINA
 DIVISION OF HIGHWAYS
 ROADWAY SUMMARY OF QUANTITIES FOR CONTRACT - C201758

ItemNumber	Sec #	Quantity	Unit	Description	ItemNumber	Sec #	Quantity	Unit	Description	ItemNumber	Sec #	Quantity	Unit	Description
000100000-N	800	Lump Sum		MOBILIZATION	304500000-E	862	50	LF	STEEL BM GUARDRAIL, SHOP CURVED	609000000-E	1610	630	TON	STONE FOR EROSION CONTROL, CLASS B
002900000-N	SP	Lump Sum		REINFORCED BRIDGE APPROACH FILL, STATION ***** (20+71.50)	315000000-N	862	5	EA	ADDITIONAL GUARDRAIL POSTS	601200000-E	1610	380	TON	SEDIMENT CONTROL STONE
004300000-N	226	Lump Sum		GRADING	319500000-N	862	1	EA	GUARDRAIL ANCHOR UNITS, TYPE AT-1	601500000-E	1615	1.5	ACR	TEMPORARY MULCHING
005000000-E	226	1	ACR	SUPPLEMENTARY CLEARING & GRUBBING	327000000-N	SP	3	EA	GUARDRAIL ANCHOR UNITS, TYPE 350	601800000-E	1620	50	LB	SEED FOR TEMPORARY SEEDING
005700000-E	226	350	CY	UNDERCUT EXCAVATION	331700000-N	862	4	EA	GUARDRAIL ANCHOR UNITS, TYPE B-77	602100000-E	1620	0.25	TON	FERTILIZER FOR TEMPORARY SEEDING
013400000-E	240	60	CY	DRAINAGE DITCH EXCAVATION	362800000-E	876	10	TON	RIP RAP, CLASS I	602400000-E	1622	120	LF	TEMPORARY SLOPE DRAINS
019500000-E	265	350	CY	SELECT GRANULAR MATERIAL	364900000-E	876	95	TON	RIP RAP, CLASS B	602700000-N	1622	2	EA	INLET PROTECTION AT TEMPORARY SLOPE DRAINS
019600000-E	270	1,000	SY	FABRIC FOR SOIL STABILIZATION	365600000-E	876	875	SY	FILTER FABRIC FOR DRAINAGE	602900000-E	SP	300	LF	SAFETY FENCE
031800000-E	300	40	TON	FOUNDATION CONDITIONING MATERIAL, MINOR STRS	440000000-E	1110	80	SF	WORK ZONE SIGNS (STATIONARY)	603000000-E	1630	1,915	CY	SILT EXCAVATION
034300000-E	310	132	LF	15" SIDE DRAIN PIPE	440500000-E	1110	112	SF	WORK ZONE SIGNS (PORTABLE)	603600000-E	1631	770	SY	MATting FOR EROSION CONTROL
070800000-E	310	200	LF	15" BIT COAT CS PIPE CULVERTS, TYPE B 0.064" THICK	441000000-E	1110	52	SF	WORK ZONE SIGNS (BARRICADE MOUNTED)	603800000-E	SP	645	SY	PERMANENT SOIL REINFORCEMENT MAT
080600000-E	310	6	EA	15" BIT COAT CS PIPE ELBOWS, TYPE B 0.064" THICK	443000000-N	1130	50	EA	DRUMS	604200000-E	1632	20	LF	1/4" HARDWARE CLOTH
099500000-E	340	72	LF	PIPE REMOVAL	443500000-N	1135	30	EA	CONES	607000000-N	SP	8	EA	SPECIAL STILLING BASINS
112100000-E	520	160	TON	AGGREGATE BASE COURSE	444500000-E	1145	48	LF	BARRICADES (TYPE III)	6071030000-E	SP	450	LF	COIR FIBER BAFFLES
122000000-E	545	90	TON	INCIDENTAL STONE BASE	445000000-N	1150	400	HR	FLAGGER	608400000-E	1660	2	ACR	SEEDING & MULCHING
127500000-E	600	110	GAL	PRIME COAT	446500000-N	1160	2	EA	TEMPORARY CRASH CUSHIONS	608700000-E	1660	1	ACR	MOWING
148900000-E	610	570	TON	ASPHALT CONC BASE COURSE, TYPE B25.0B	447000000-N	1160	2	EA	RESET TEMPORARY CRASH CUSHIONS	609000000-E	1661	50	LB	SEED FOR REPAIR SEEDING
149800000-E	610	420	TON	ASPHALT CONC INTERMEDIATE COURSE, TYPE 119.0B	448000000-N	1165	1	EA	TMIA	609300000-E	1661	0.25	TON	FERTILIZER FOR REPAIR SEEDING
152500000-E	610	840	TON	ASPHALT CONC SURFACE COURSE, TYPE SF9.5A	448500000-E	1170	760	LF	PORTABLE CONCRETE BARRIER	609600000-E	1662	50	LB	SEED FOR SUPPLEMENTAL SEEDING
156000000-E	620	100	TON	ASPHALT BINDER FOR PLANT MIX, GRADE PG 64-22	465000000-N	1251	68	EA	TEMPORARY RAISED PAVEMENT MARKERS	610800000-E	1665	1.25	TON	FERTILIZER TOPDRESSING
200000000-N	806	5	EA	RIGHT OF WAY MARKERS	481000000-E	1205	18,900	LF	PAINT PAVEMENT MARKING LINES (4")	611400000-N	SP	2	HR	SPECIALIZED HAND MOWING
228600000-N	840	1	EA	MASONRY DRAINAGE STRUCTURES	484700000-E	1205	5,400	LF	POLYUREA PAVEMENT MARKING LINES (4", *****) (STANDARD GLASS BEADS)	611700000-N	SP	27	EA	RESPONSE FOR EROSION CONTROL
236700000-N	840	1	EA	FRAME WITH TWO GRATES, STD 840.29	490000000-N	1251	17	EA	PERMANENT RAISED PAVEMENT MARKERS	612300000-E	1670	0.4	ACR	REFORESTATION
255600000-E	846	52	LF	SHOULDER BERM GUTTER	600000000-E	1605	1,720	LF	TEMPORARY SILT FENCE					
303000000-E	862	550	LF	STEEL BM GUARDRAIL	600600000-E	1610	185	TON	STONE FOR EROSION CONTROL, CLASS A					

SUMMARY OF EARTHWORK

IN CUBIC YARDS

LOCATION	UNCLASSIFIED EXCAVATION	UNDERCUT	EMBT + %	BORROW	WASTE
SUMMARY NO. 1					
-L- 14+00 TO 19+99 (BRIDGE)	853		3514	2661	
-DR- 10+25 TO 12+00	5		1451	1446	
TOTAL SUMMARY NO. 1	858		4965	4107	
SUMMARY NO. 2					
-L- 21+44 (BRIDGE) TO 27+50	1947		3141	1194	
TOTAL SUMMARY NO. 2	1947		3141	1194	
SUB-TOTAL SUMMARY NOS. 1 & 2					
	2805		8106	5301	
EST. LOSS DUE TO CLEARING & GRUBBING	-200			200	
PROJECT TOTALS					
	2605		8106	5501	
EST. FOR REPLACING TOPSOIL ON BORROW PITS				275	
GRAND TOTALS					
	2605			5776	
SAY	2650			5900	

ADDITIONAL UNDERCUT = 350 CY
 SELECT GRANULAR MATERIAL - 350 CY
 ESTIMATE DDE = 60 CY

Note: Approximate quantities only. Unclassified Excavation, Borrow Excavation, Fine Grading, Clearing and Grubbing, and Removal of Existing Pavement will be paid for at the contract lump sum price for "Grading."

NOTE: Earthwork quantities are calculated by the Roadway Design Unit. These earthwork quantities are based in part on subsurface data provided by the Geotechnical Engineering Unit.

COMPUTED BY: DCW DATE: 3/31/06
 CHECKED BY: MAY DATE: 9/12/07

STATE OF NORTH CAROLINA
 DIVISION OF HIGHWAYS

LIST OF PIPES, ENDWALLS, ETC. (FOR PIPES 48" & UNDER)

STATION	SIZE	THICKNESS OR GAUGE	LOCATION (LT, RT, OR CI)	STRUCTURE NO.		TOP ELEVATION	INVERT ELEVATION	SLOPE CRITICAL	CLASS III R.C. PIPE (UNLESS NOTED OTHERWISE)								BITUMINOUS COATED C.S. PIPE TYPE B (UNLESS NOTED OTHERWISE)								CLASS III R.C. PIPE OR ALUMINIZED C.S. PIPE, TYPE IR OR HDPE PIPE, TYPE S OR D								ENDWALLS STD. 838.01, STD. 838.11 OR STD. 838.80 (UNLESS NOTED OTHERWISE)	QUANTITIES FOR DRAINAGE STRUCTURES * TOTAL L.F. FOR PAY QUANTITY SHALL BE COL. 'A' + (1.3 X COL. 'B')	FRAME, GRATES AND HOOD STANDARD 840.03	G.D.I. (N.S.) FRAME WITH TWO GRATES STD. 840.29	CORR. STEEL ELBOWS NO. & SIZE	CONC. COLLARS CL. "B" C.Y. STD. 840.72	CONC. & BRICK PIPE PLUG, C.Y. STD. 840.71	PIPE REMOVAL LINF.T.	ABBREVIATIONS	
				FROM	TO				12"	15"	18"	24"	30"	36"	42"	48"	12"	15"	18"	24"	30"	36"	42"	48"	12"	15"	18"	24"	30"	36"	42"	48"									REMARKS	
				CU. YDS.					PER EACH (0' THRU 9.0')	5.0' THRU 10.0'	10.0' AND ABOVE	TYPE OF GRATE		E		F		G																								
-L- 15+15	LT	1																																								
-L- 18+30	RT	2																																								
-L- 19+56	LT	3			681.0	678.2																																				
-L- 19+56	LT	3	4		678.2	668.5																																				
-L- 20+15	RT	5			666.0	650.0																																				
-L- 21+50	RT	6			667.0	651.0																																				
-L- 25+78	RT	7																																								
-L- 27+02	RT	8																																								
-L- 25+40	RT	9																																								
TOTALS											200																															

"N" = DISTANCE FROM EDGE OF LANE TO FACE OF GUARDRAIL.
 TOTAL SHOULDER WIDTH = DISTANCE FROM EDGE OF TRAVEL LANE TO SHOULDER BREAK POINT.
 FLARE LENGTH = DISTANCE FROM LAST SECTION OF PARALLEL GUARDRAIL TO END OF GUARDRAIL.
 W = TOTAL WIDTH OF FLARE FROM BEGINNING OF TAPER TO END OF GUARDRAIL.
 G = GATING IMPACT ATTENUATOR TYPE 350
 NG = NON-GATING IMPACT ATTENUATOR TYPE 350

GUARDRAIL SUMMARY

SURVEY LINE	BEG. STA.	END STA.	LOCATION	LENGTH			WARRANT POINT		"N" DIST. FROM E.O.L.	TOTAL SHOULDER WIDTH	FLARE LENGTH		W		ANCHORS											IMPACT ATTENUATOR TYPE 350	SINGLE FACED GUARDRAIL	REMOVE EXISTING GUARDRAIL	REMOVE AND STOCKPILE EXISTING GUARDRAIL	REMARKS								
				STRAIGHT	SHOP CURVED	DOUBLE FACED	APPROACH END	TRAILING END			APPROACH END	TRAILING END	APPROACH END	TRAILING END	XI MOD	B-77	GRAU 350	M-350	XIII	CAT-1	VI MOD	BIC	AT-1															
				EA		G		NG																														
-L-	18+61.50	19+99.00	LT	137.50					11																													
-L-	18+54.93	19+99.00	RT	137.50	50				6		106.2		2.1																									
-L-	21+44.00	24+44.00	LT	300.00					11																													
-L-	21+44.00	23+44.00	RT	200.00					6																													
SUB TOTALS				775.00	50																																	
ANCHOR DEDUCTIONS				231.25																																		
TOTALS				543.75	50																																	
SAY				550.00	50																																	
ADDITIONAL POSTS - 5 EA.																																						

D:\G\2007\pawley\pawley\4104_r\dj_3serires.dgn

5/28/99

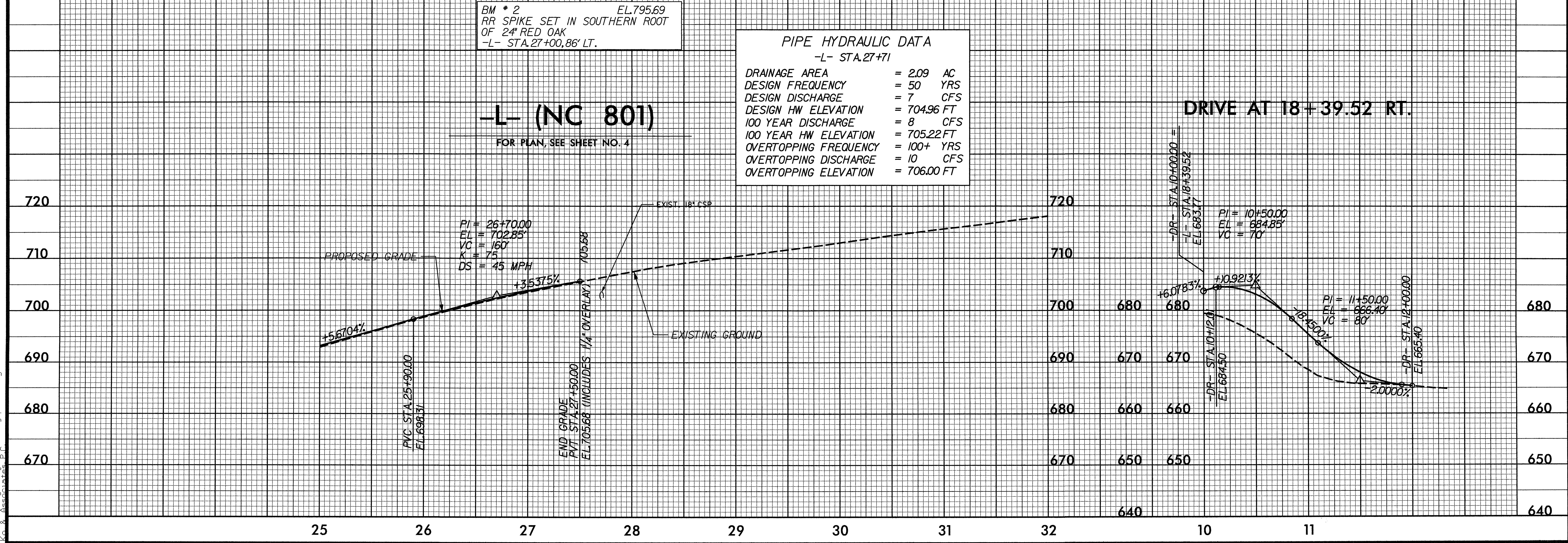
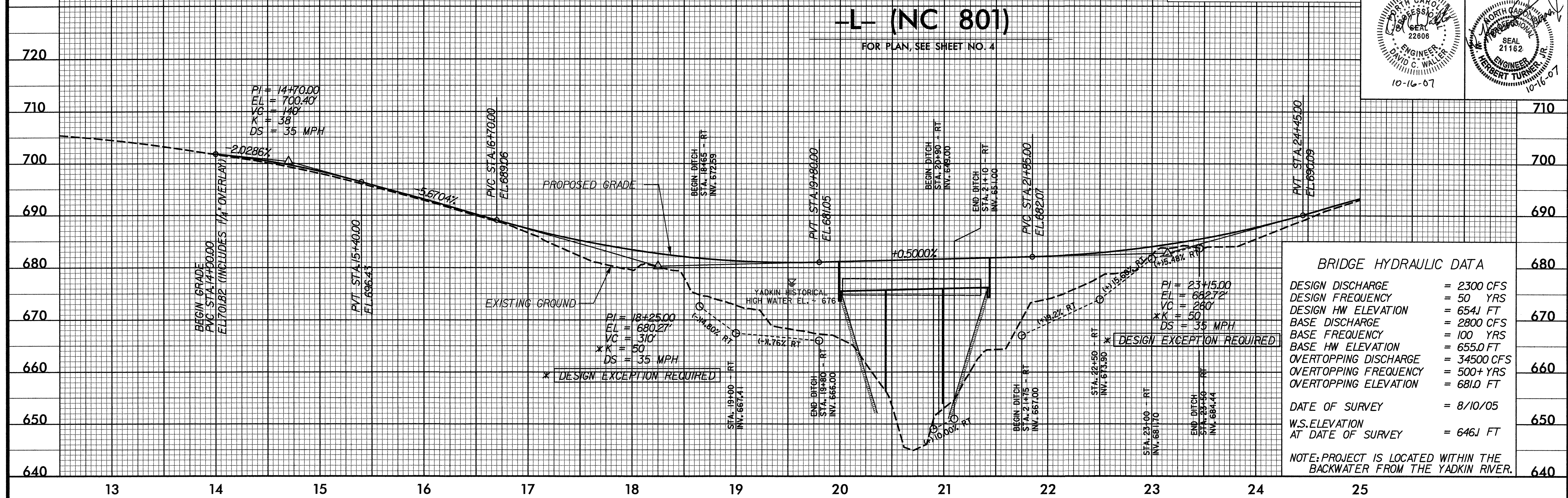

0:\15\2007\AP\c\15\4104_r.dwg_pfl_05.dgn