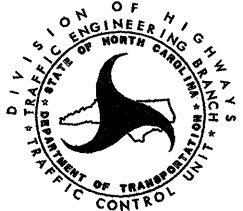

FINAL PAV'T MARKING SCHEDULE

SYMBOL	DESCRIPTION	QUANTITY BREAKDOWN	PAY ITEM	TOTAL QUANTITY
PAVEMENT MARKING LINES				
			THERMOPLASTIC (4", 90 mils)	
TA	WHITE EDGELINE	1,184 ft		
TB	YELLOW EDGELINE	424 ft		
			TOTAL	1,608 ft
THERMOPLASTIC (4", 120 mils)				
TC	10 ft. WHITE SKIP	480 ft		
TD	2 ft. WHITE MINISKIP	136 ft		
TE	WHITE SOLID LANE LINE	1,169 ft		
TF	10 ft. YELLOW SKIP	1,373 ft		
TH	YELLOW SINGLE CENTER LINE	5,489 ft		
TI	YELLOW DOUBLE CENTER LINE	1,474 ft		
			TOTAL	10,121 ft
THERMOPLASTIC (8", 90 mils)				
TP	WHITE GORELINE	187 ft		
TT	YELLOW DIAGONAL	17 ft		
			TOTAL	204 ft
THERMOPLASTIC (24", 120 mils)				
T2	WHITE STOPBAR	150 ft		
			TOTAL	150 ft
PAVEMENT MARKING SYMBOLS				
THERMOPLASTIC THICK SYMBOL (90 mils)				
UA	LEFT TURN ARROW	26 ea		
UB	RIGHT TURN ARROW	10 ea		
UC	STRAIGHT ARROW	5 ea		
			TOTAL	41 ea
THERMOPLASTIC THICK CHARACTER (120 mils)				
UI	ALPHANUMERIC CHARACTER	8 ea		
			TOTAL	8 ea
PAVEMENT MARKERS				
SNOWPLOWABLE RAISED				
ME	YELLOW AND YELLOW	87 ea		
MF	CRYSTAL AND RED	117 ea		
			TOTAL	204 ea

SEE ROADWAY STANDARD DRAWING NUMBERS 1205.01, 1205.02, 1205.04, 1205.05, 1205.06, 1205.08, 1205.09, 1250.01 AND 1253.01

APPROVED: <i>Michael Rzeznick</i>	DATE: 10-16-07	FINAL PAVEMENT MARKING PLAN	
SEAL 	SCALE: NONE		REVISIONS
	DATE: 10-07		
	DWG. BY: BLM		
	DESIGN BY: BLM		
REVIEWED BY: MTR			CADD FILE

Plans prepared by:
KO & ASSOCIATES, P.C.
 Consulting Engineers
 101 SCHAUB DR., SUITE #202
 RALEIGH, N.C. 27606
 For Division of Highways

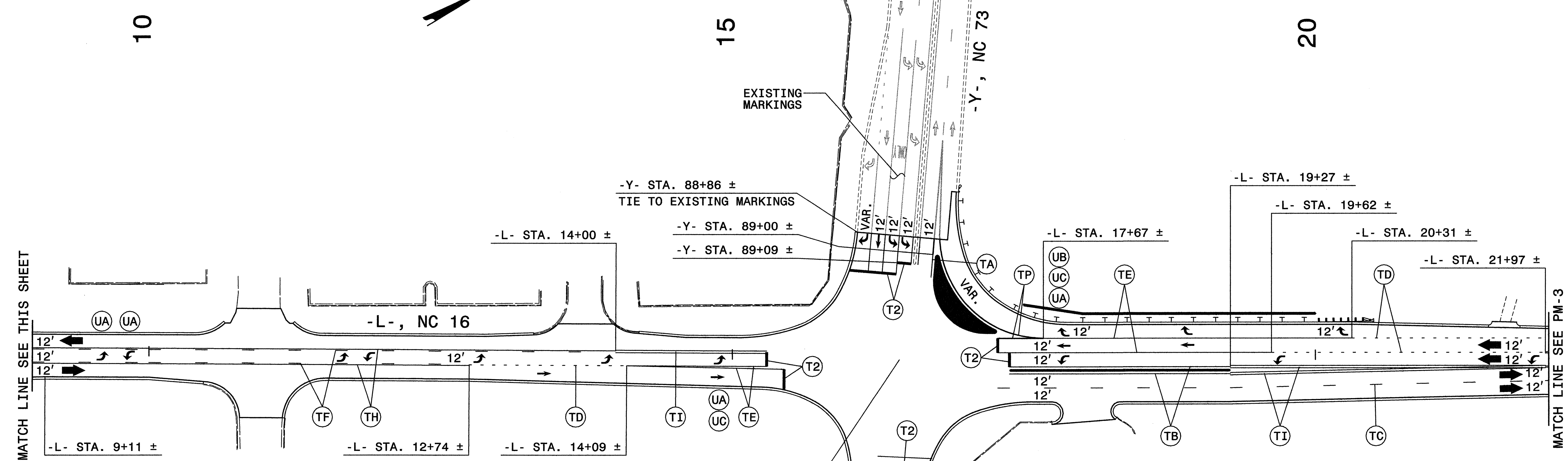

NOTE:
 ALL STOPBARS AND ARROW SYMBOLS
 AT THE INTERSECTION OF NC 16 / NC 73
 ARE TO BE PLACED AS DIRECTED BY
 THE ENGINEER.

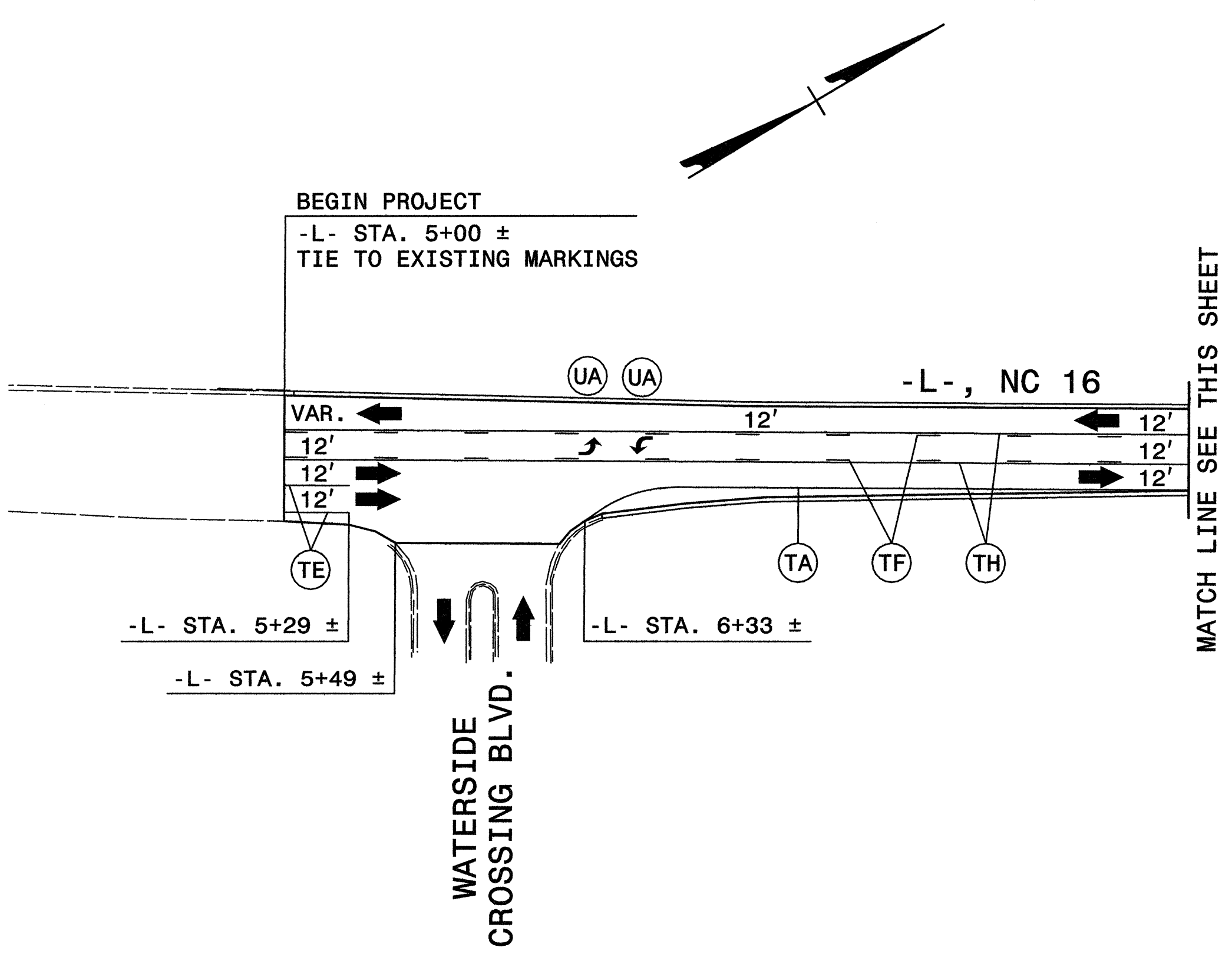

NOTES:

- SEE SHEET PM-1, FOR FINAL PAVEMENT MARKING SCHEDULE.
- PAVEMENT MARKINGS, SYMBOLS, AND CHARACTERS ARE TO BE MARKED ACCORDING TO ROADWAY STANDARD DRAWINGS UNLESS OTHERWISE NOTED IN THE PLANS.
- PAVEMENT MARKERS ARE TO BE SPACED ACCORDING TO THE ROADWAY STANDARD DRAWINGS.

APPROVED: *Michael T. Rieper* DATE: 10-16-07



FINAL PAVEMENT MARKING PLAN

SCALE: NONE		REVISIONS
DATE: 10-07		
DWG. BY: BLM		
DESIGN BY: BLM		
REVIEWED BY: MTR		

10/16/2007
 R:\p\dms\37449-TC-ppm2.dgn
 KO & Associates, P.C.

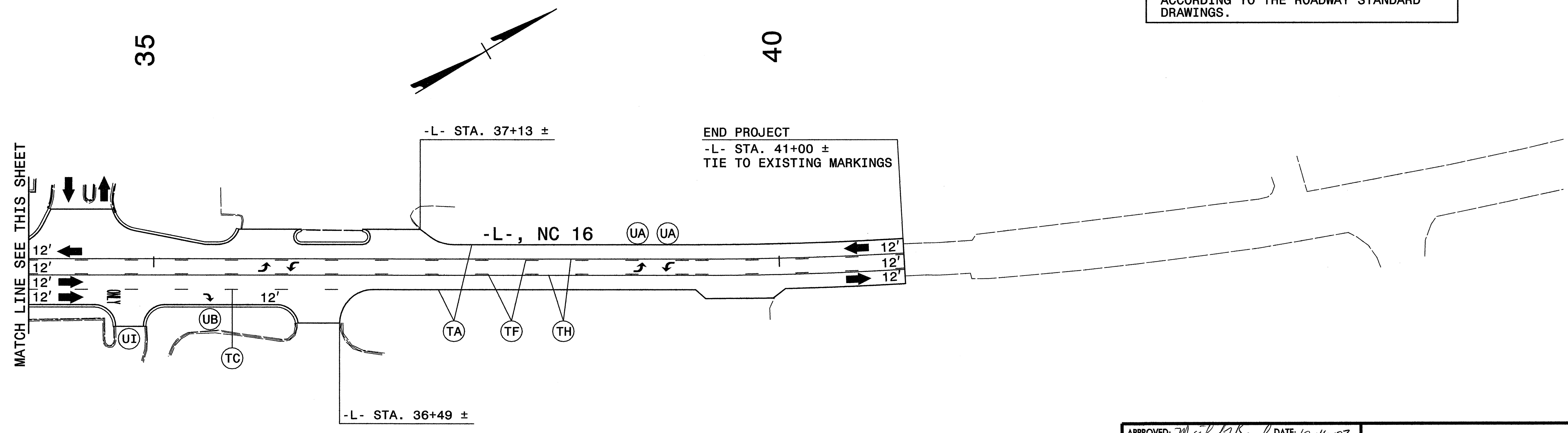
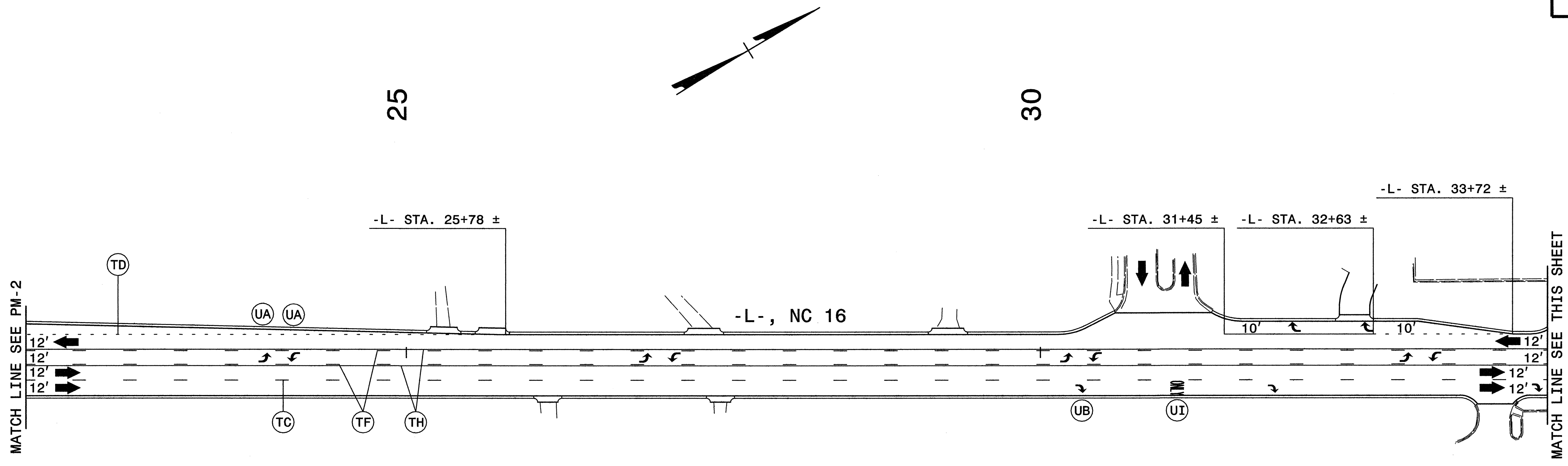

NOTES:

- SEE SHEET PM-1, FOR FINAL PAVEMENT MARKING SCHEDULE.
- PAVEMENT MARKINGS, SYMBOLS, AND CHARACTERS ARE TO BE MARKED ACCORDING TO ROADWAY STANDARD DRAWINGS UNLESS OTHERWISE NOTED IN THE PLANS.
- PAVEMENT MARKERS ARE TO BE SPACED ACCORDING TO THE ROADWAY STANDARD DRAWINGS.

APPROVED: <i>Michael Rzepka</i> DATE: 10-16-07	FINAL PAVEMENT MARKING PLAN		
SEAL			SCALE: NONE
	DATE: 10-07		
	DWG. BY: BLM		REVISIONS
	DESIGN BY: BLM		
	REVIEWED BY: MTR		