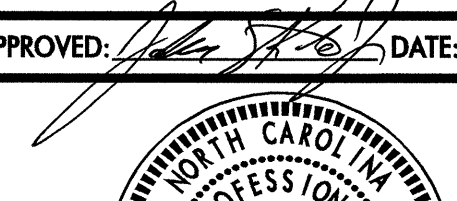
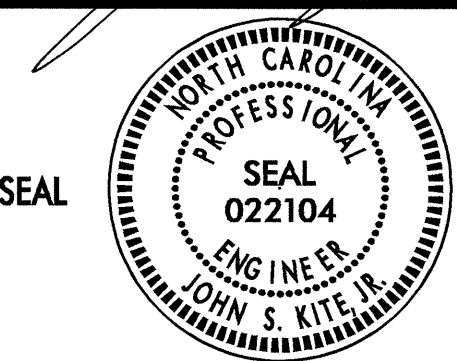

FINAL PAVEMENT MARKING SCHEDULE

SYMBOL	DESCRIPTION	QUANTITY BREAKDOWN	TOTAL QUANTITY
		<u>THERMOPLASTIC(16", 120 MILS)</u>	
T1	WHITE LINE, RR CROSSBUCK	40 LF	TOTAL 40 LF
		<u>THERMOPLASTIC(24", 120 MILS)</u>	
T2	WHITE STOPBAR	195 LF	TOTAL 195 LF
		<u>THERMOPLASTIC(4", 120 MILS)</u>	
TI	YELLOW DOUBLE CENTER	4890 LF	TOTAL 4890 LF
		<u>THERMOPLASTIC(4", 90 MILS)</u>	
TA	WHITE EDGELINE	4830 LF	TOTAL 4830 LF
		<u>THERMOPLASTIC(6", 120 MILS)</u>	
TJ	10 FT. WHITE SKIP	22165 LF	
TK	2 FT. WHITE MINISKIP	1048 LF	
TL	WHITE SOLID LANE LINE	500 LF	TOTAL 23713 LF
		<u>THERMOPLASTIC(6", 90 MILS)</u>	
T6	WHITE EDGELINE	44330 LF	
T7	YELLOW EDGELINE	44330 LF	TOTAL 88660 LF
		<u>THERMOPLASTIC(8", 90 MILS)</u>	
TP	WHITE GORELINE	11350 LF	
TQ	WHITE DIAGONAL	627 LF	
TT	YELLOW DIAGONAL	294 LF	TOTAL 12271 LF
		<u>THERMOPLASTIC PAVEMENT MARKING SYMBOLS (90 MILS)</u>	
UA	LEFT TURN ARROW	47 EA	
UB	RIGHT TURN ARROW	17 EA	
UC	STRAIGHT ARROW	10 EA	TOTAL 74 EA
		<u>THERMOPLASTIC PAVEMENT MARKING CHARACTER (120 MILS)</u>	
UI	RR	2 EA	TOTAL 2 EA
		<u>SNOWPLOWABLE PAVEMENT MARKERS</u>	
ME	YELLOW & YELLOW	61 EA	
MF	CRYSTAL & RED	904 EA	TOTAL 965 EA

29-AUG-2007 13:20
 \\dot\dfsroot\01\Proj\Tpp\projects-r\2510a\traffic\trafficcontrol\top\pm\2510a-fo-01.dgn
 ir-spence AT W1122410

APPROVED:  DATE: 9/1/05 	FINAL PAVEMENT MARKING SCHEDULE				
SCALE: NONE DATE: MAR 05 DWG. BY: SJS DESIGN BY: MHS REVIEWED BY: DAP	<table border="1" style="width: 100%; border-collapse: collapse;"> <tr> <th style="text-align: left;">REVISIONS</th> </tr> <tr> <td> </td> </tr> <tr> <td> </td> </tr> <tr> <td> </td> </tr> </table>	REVISIONS			
REVISIONS					

NOTE:

SEE RSD 1250.01 AND 1253.01 FOR LOCATION AND PLACEMENT OF SNOWPLOWABLE PAVEMENT MARKERS

ALL SNOWPLOWABLE PAVEMENT MARKERS ARE ON 80 FT. CENTERS UNLESS OTHERWISE SHOWN ON THE PLANS.

ALL SYMBOLS ARE THERMOPLASTIC UNLESS OTHERWISE LABELLED ON THE PLAN.

SYMBOL SPACING ALONG -L- IS 240 FT. UNLESS OTHERWISE SHOWN ON THE PLANS. SEE PM-1 FOR SCHEDULE

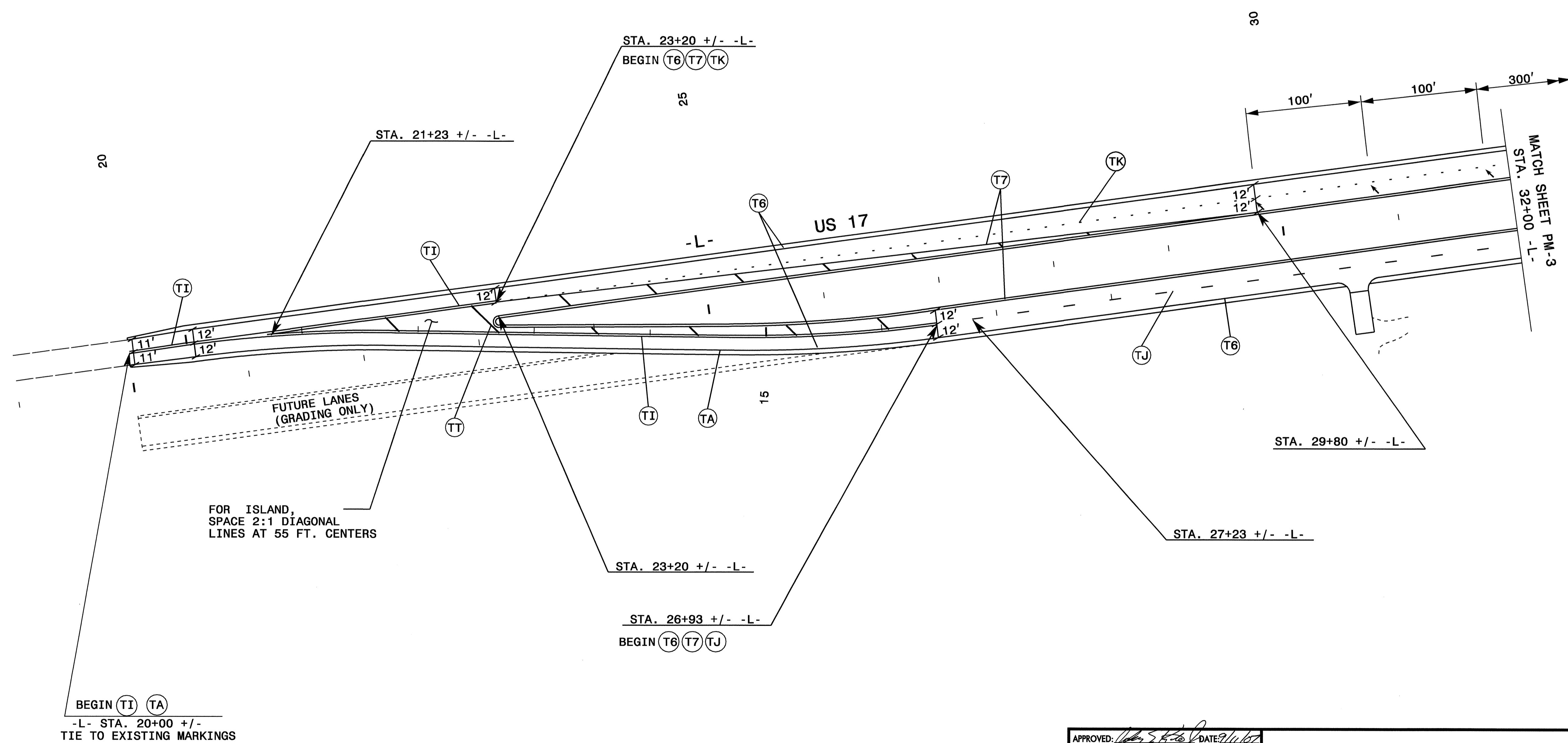

29-AUG-2007 13:20
 \\dot\dfsroot\01\Proj\11pp\projects-r\2510a\traffic\trafficcontrol\top\pm's\2510a-rc-pm02.dgn
 Jrspeice AT WZTC2401

APPROVED: <i>[Signature]</i> DATE: 9/1/05	<h2 style="text-align: center;">PAVEMENT MARKINGS</h2>	SCALE: NONE		REVISIONS		
		DATE: 2/05		<table border="1"> <tr><td> </td></tr> <tr><td> </td></tr> <tr><td> </td></tr> <tr><td> </td></tr> </table>		
DESIGN BY: SJS	REVIEWED BY: DAP	CADD FILE				

NOTE:

SEE RSD 1250.01 AND 1253.01 FOR LOCATION AND PLACEMENT OF SNOWPLOWABLE PAVEMENT MARKERS

ALL SNOWPLOWABLE PAVEMENT MARKERS ARE ON 80 FT. CENTERS UNLESS OTHERWISE SHOWN ON THE PLANS.

ALL SYMBOLS ARE THERMOPLASTIC UNLESS OTHERWISE LABELLED ON THE PLAN.

SYMBOL SPACING ALONG -L- IS 240 FT. UNLESS OTHERWISE SHOWN ON THE PLANS. SEE PM-1 FOR SCHEDULE

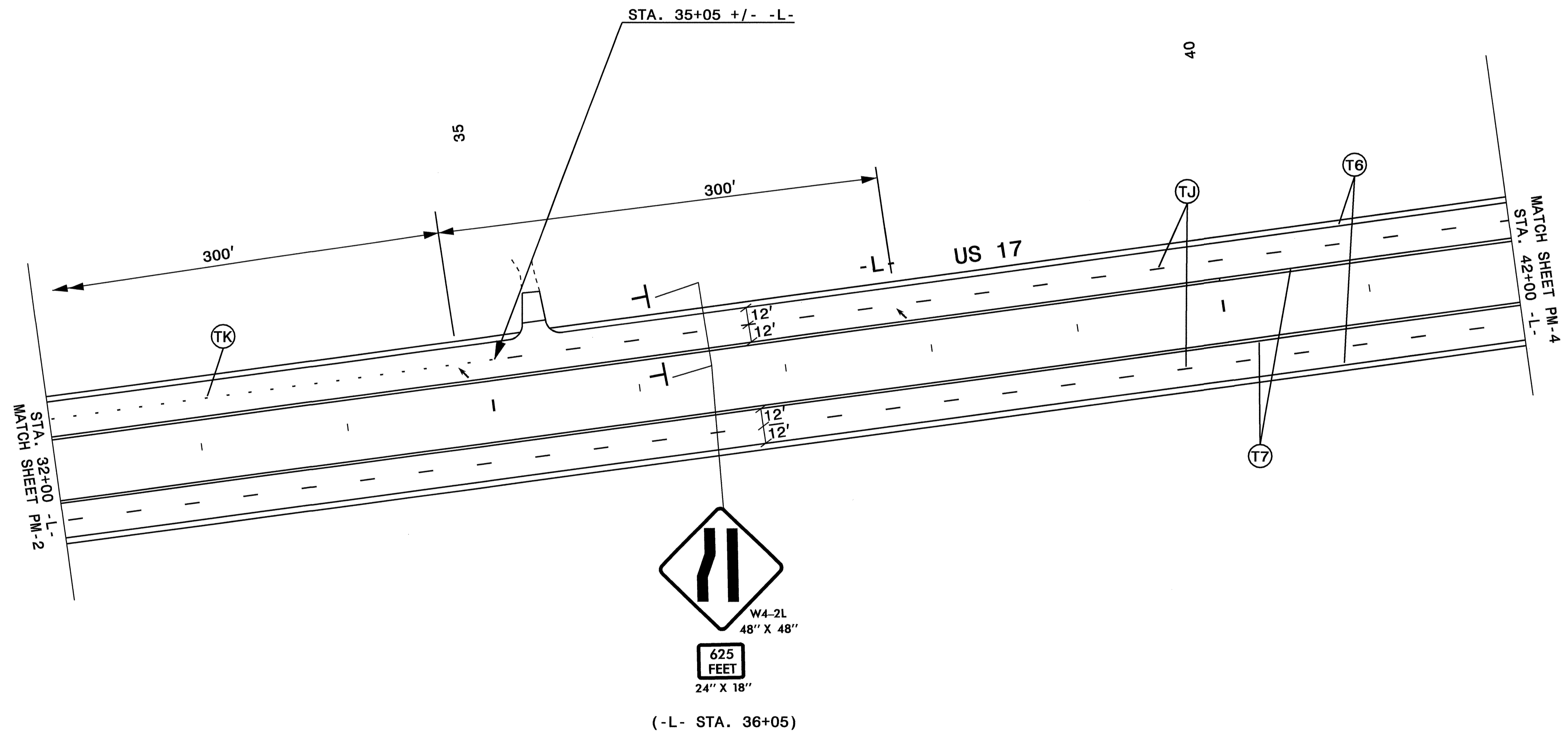

29-AUG-2007 13:21 \\dot\dfs\o\p\p\projects-r\2510a\traffic\trafficcontrol\top\pm\s\vr\2510a-rc-pm03.dgn
 jrspence AT WZIC2240

APPROVED: DATE: 3/1/07	PAVEMENT MARKINGS	
SCALE: NONE		REVISIONS
DATE: MAR 05		
DWG. BY: MHS		
DESIGN BY: MHS		
REVIEWED BY: DAP		CADD FILE

NOTE:

SEE RSD 1250.01 AND 1253.01 FOR LOCATION AND PLACEMENT OF SNOWPLOWABLE PAVEMENT MARKERS

ALL SNOWPLOWABLE PAVEMENT MARKERS ARE ON 80 FT. CENTERS UNLESS OTHERWISE SHOWN ON THE PLANS.

ALL SYMBOLS ARE THERMOPLASTIC UNLESS OTHERWISE LABELLED ON THE PLAN.

SYMBOL SPACING ALONG -L- IS 240 FT. UNLESS OTHERWISE SHOWN ON THE PLANS. SEE PM-1 FOR SCHEDULE

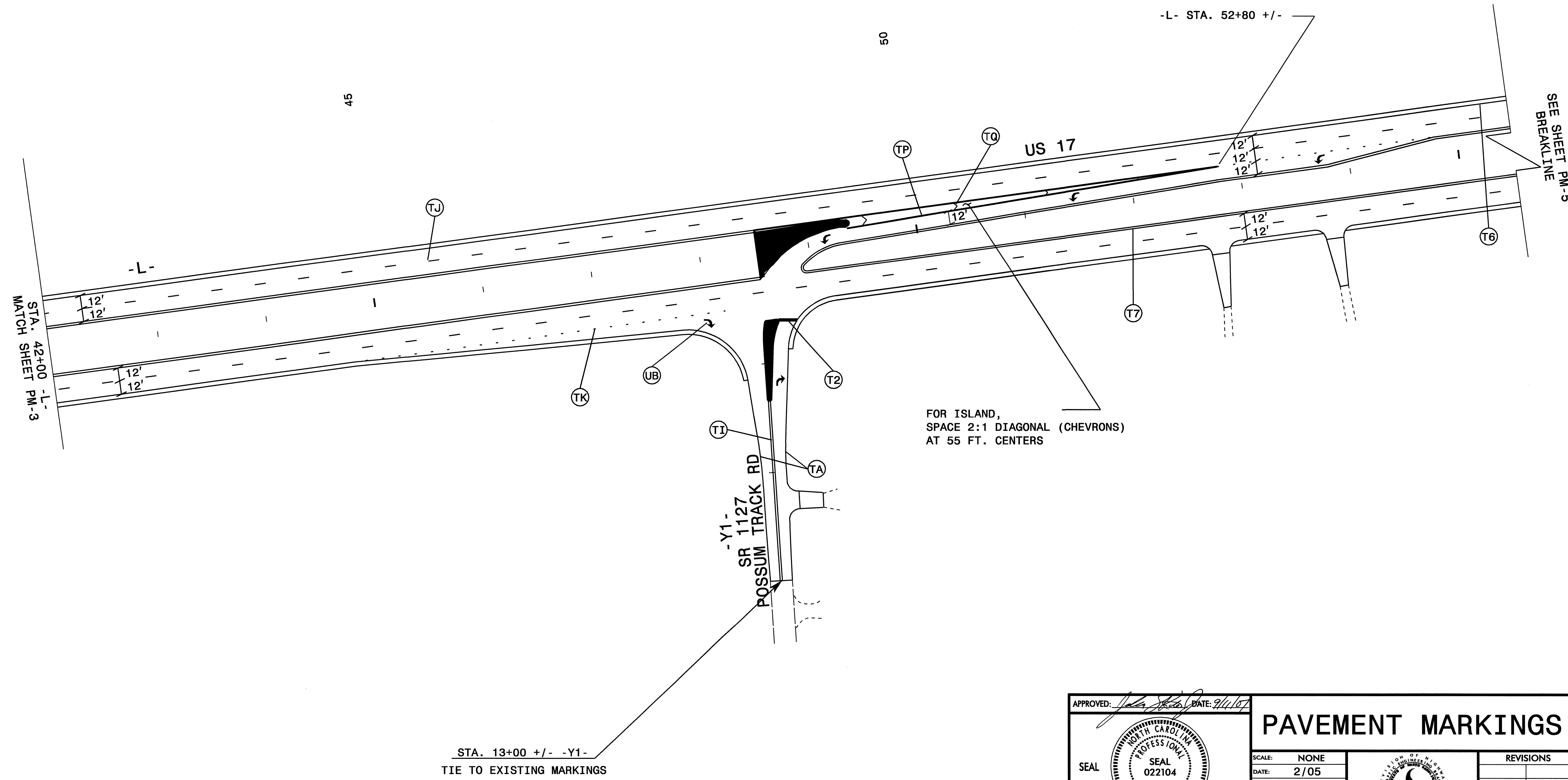

29-AUG-2007 13:21
 \\dot\dfsroot\1\Pro\N\pprjects-r\2510a\traffic\top\pm\sr\2510a-rc-pm04.dgn
 Trsperce AT 12/22/01

APPROVED: <i>[Signature]</i> DATE: 9/1/07	PAVEMENT MARKINGS	SCALE: NONE		REVISIONS
		DATE: 2/05		
	DWG. BY: SJS			
	DESIGN BY: SJS			
	REVIEWED BY: DAP			

NOTE:

SEE RSD 1250.01 AND 1253.01 FOR LOCATION AND PLACEMENT OF SNOWPLOWABLE PAVEMENT MARKERS

ALL SNOWPLOWABLE PAVEMENT MARKERS ARE ON 80 FT. CENTERS UNLESS OTHERWISE SHOWN ON THE PLANS.

ALL SYMBOLS ARE THERMOPLASTIC UNLESS OTHERWISE LABELLED ON THE PLAN.

SYMBOL SPACING ALONG -L- IS 240 FT. UNLESS OTHERWISE SHOWN ON THE PLANS. SEE PM-1 FOR SCHEDULE

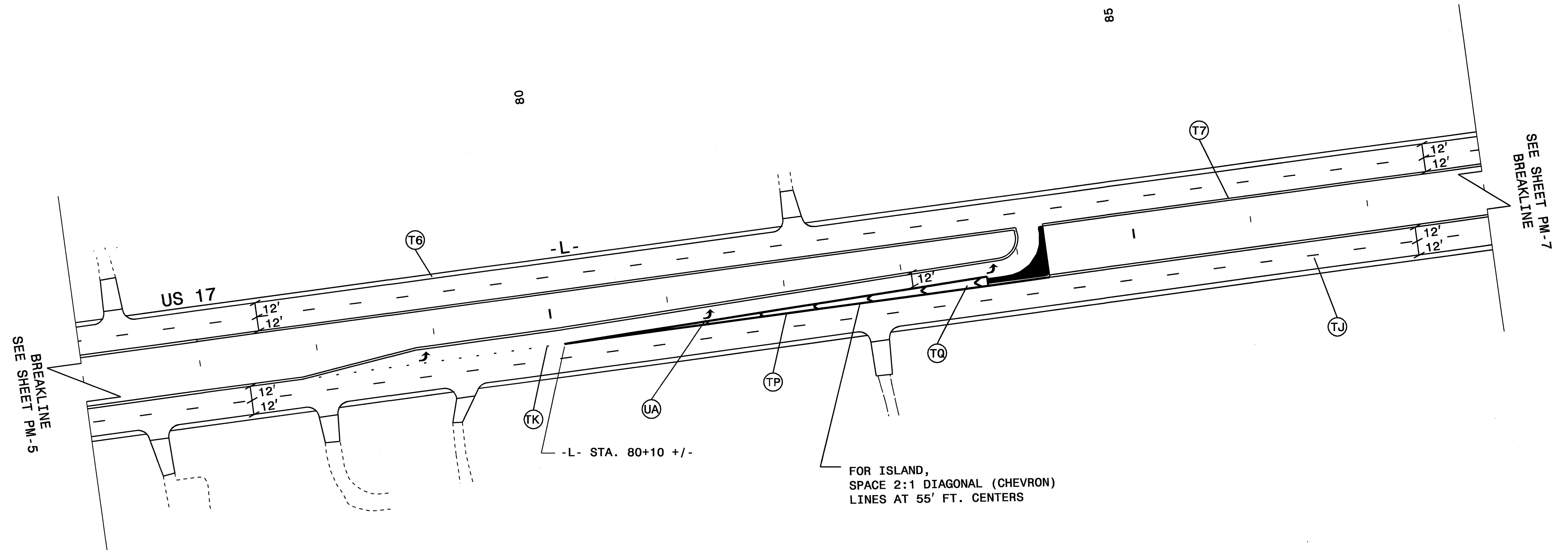
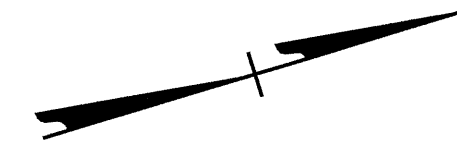

29-AUG-2007 13:22
 \\doan\cristoforo\p\proj\projects-r\2510a\traffic\affico\tr\top\pm\2510a-rc-pm06.dgn
 J:spence - AT: MZTC2410

APPROVED:  DATE: 7/14/07

SEAL



PAVEMENT MARKINGS

SCALE: NONE
 DATE: 2/05
 DWG. BY: SJS
 DESIGN BY: SJS
 REVIEWED BY: DAP

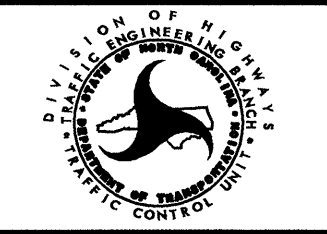

REVISIONS	

NOTE:

SEE RSD 1250.01 AND 1253.01 FOR LOCATION AND PLACEMENT OF SNOWPLOWABLE PAVEMENT MARKERS

ALL SNOWPLOWABLE PAVEMENT MARKERS ARE ON 80 FT. CENTERS UNLESS OTHERWISE SHOWN ON THE PLANS.

ALL SYMBOLS ARE THERMOPLASTIC UNLESS OTHERWISE LABELLED ON THE PLAN.

SYMBOL SPACING ALONG -L- IS 240 FT. UNLESS OTHERWISE SHOWN ON THE PLANS. SEE PM-1 FOR SCHEDULE

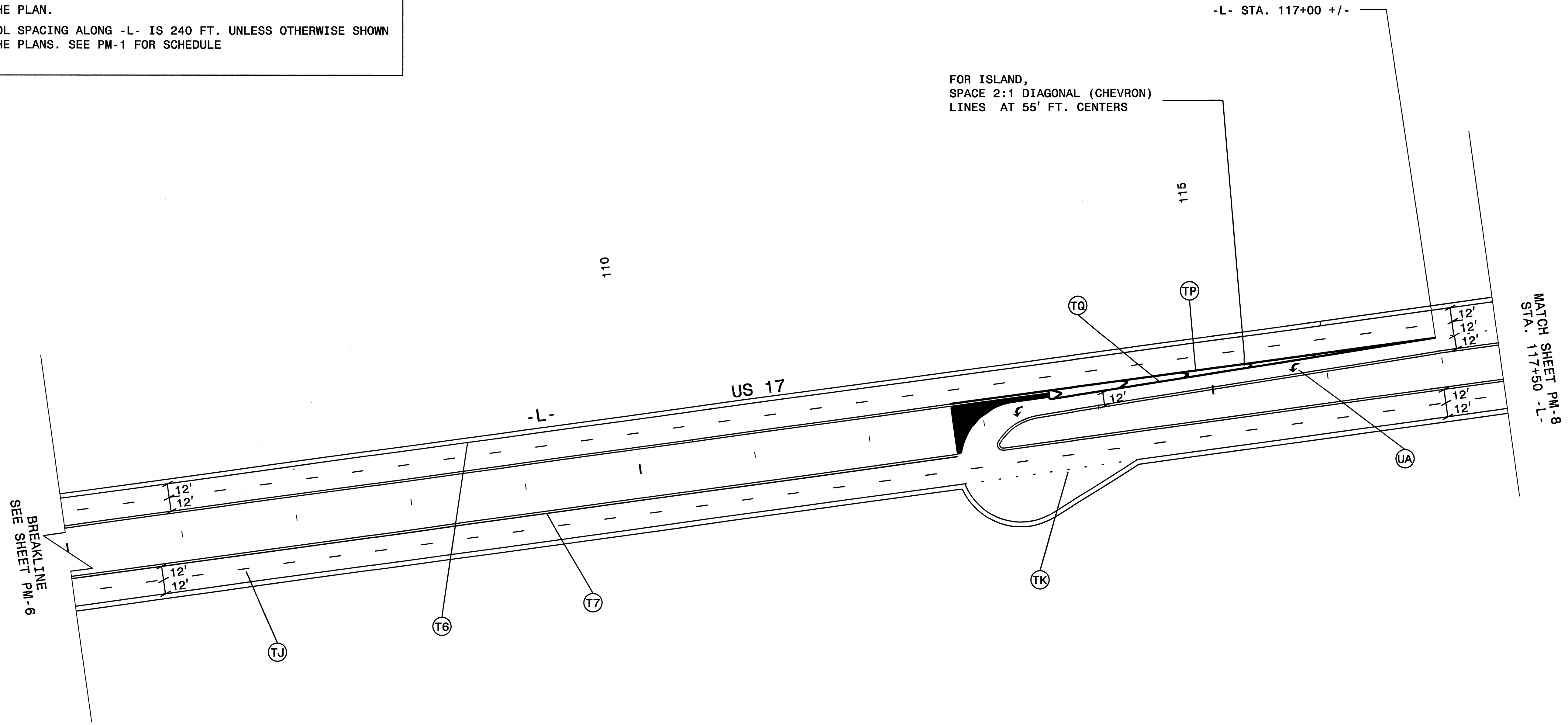
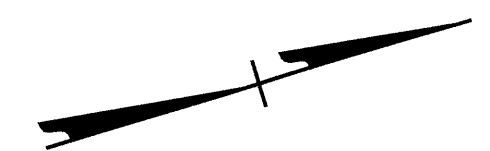

29-AUG-2007 13:23
 \\dot\dfsroot\01\Proj\Tipprjects-r\2510a\traffic\trafficcontrol\top\pm\sr\2510a-fe-pm07.dgn
 rspence AT WZTC22410

APPROVED: <i>[Signature]</i> DATE: 7/11/07	PAVEMENT MARKINGS	
SCALE: NONE		REVISIONS
DATE: 2/05		
DWG. BY: SJS		
DESIGN BY: SJS		
REVIEWED BY: DAP		CADD FILE

NOTE:

SEE RSD 1250.01 AND 1253.01 FOR LOCATION AND PLACEMENT OF SNOWPLOWABLE PAVEMENT MARKERS

THE LOCATION OF THE RAILROAD CROSSING PAVEMENT MARKINGS SHOWN IS APPROXIMATE. PLACE MARKINGS IN ACCORDANCE WITH RSD 1205.11, AS DIRECTED BY THE ENGINEER.

ALL SNOWPLOWABLE PAVEMENT MARKERS ARE ON 80 FT. CENTERS UNLESS OTHERWISE SHOWN ON THE PLANS.

ALL SYMBOLS ARE THERMOPLASTIC UNLESS OTHERWISE LABELLED ON THE PLAN.

SYMBOL SPACING ALONG -L- IS 240 FT. UNLESS OTHERWISE SHOWN ON THE PLANS. SEE PM-1 FOR SCHEDULE

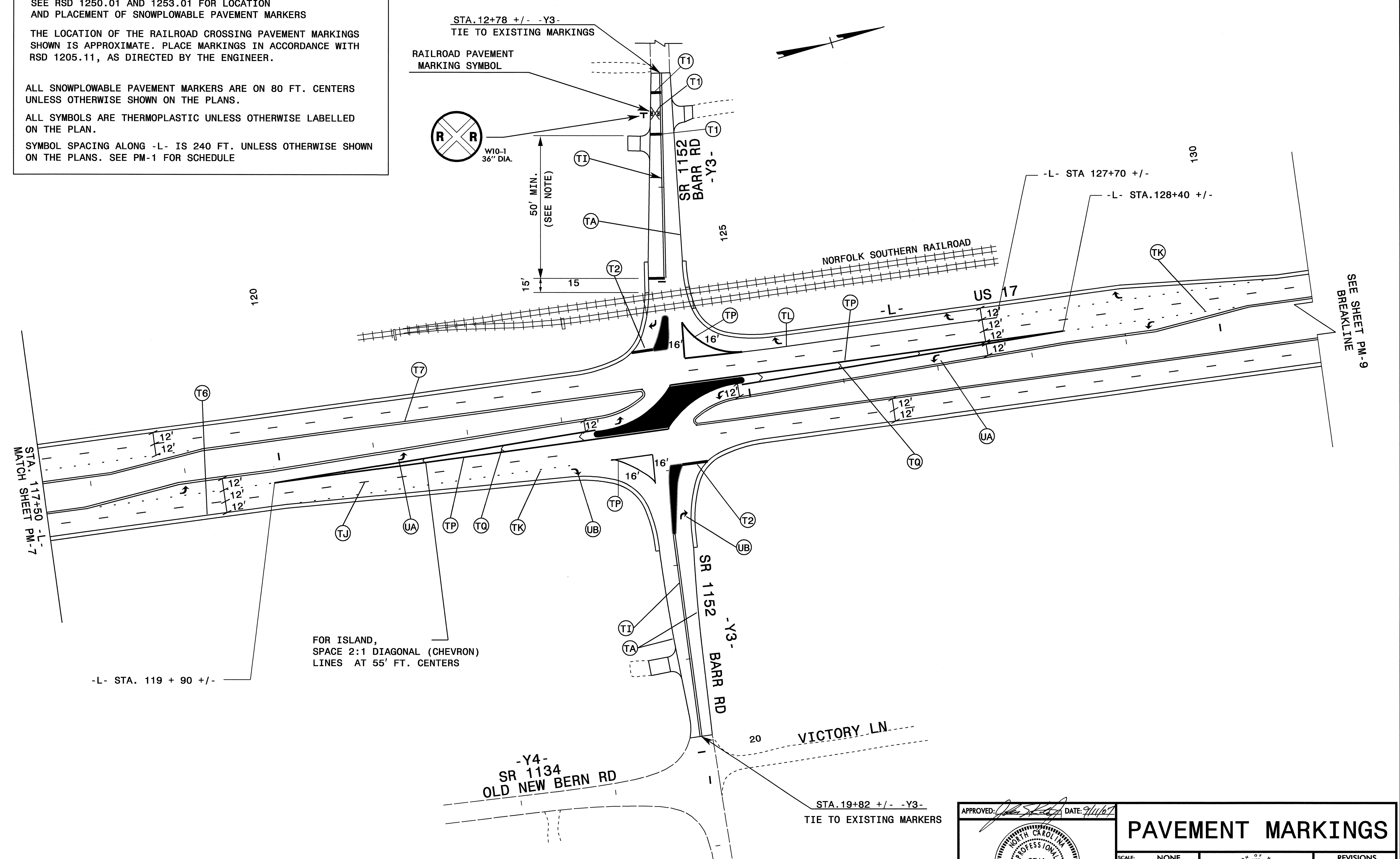

I:\SEP-2007\1554
 \Dot\dfs001\01\Proj\Tipp\projects-r\2510a\traffic\tr\affico\tr\top\pm\sr\2510a\to\pm08.dgn
 AT WZTC224167
 derichardson

APPROVED: DATE: 9/1/07	PAVEMENT MARKINGS	
SCALE: NONE		REVISIONS
DATE: 2/05		
DWG. BY: SJS		
DESIGN BY: SJS		
REVIEWED BY: DAP		

NOTE:

SEE RSD 1250.01 AND 1253.01 FOR LOCATION AND PLACEMENT OF SNOWPLOWABLE PAVEMENT MARKERS

ALL SNOWPLOWABLE PAVEMENT MARKERS ARE ON 80 FT. CENTERS UNLESS OTHERWISE SHOWN ON THE PLANS.

ALL SYMBOLS ARE THERMOPLASTIC UNLESS OTHERWISE LABELLED ON THE PLAN.

SYMBOL SPACING ALONG -L- IS 240 FT. UNLESS OTHERWISE SHOWN ON THE PLANS. SEE PM-1 FOR SCHEDULE

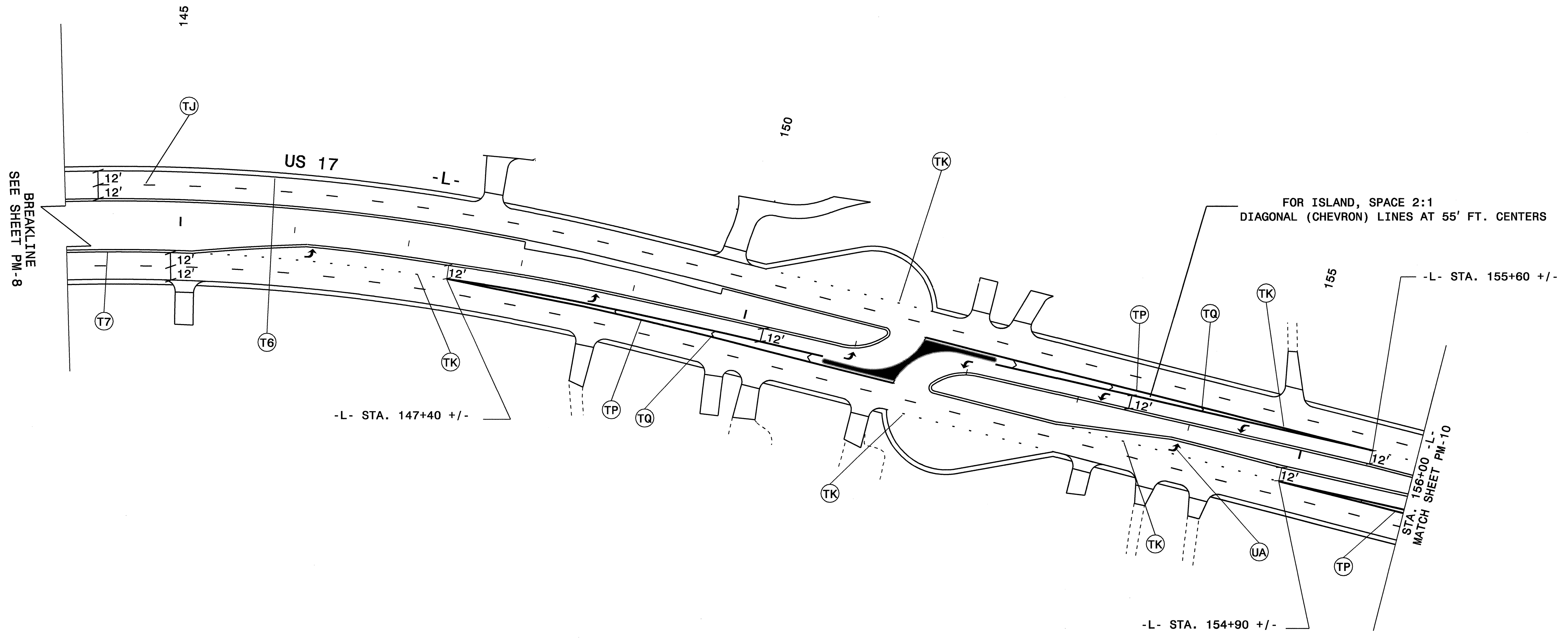
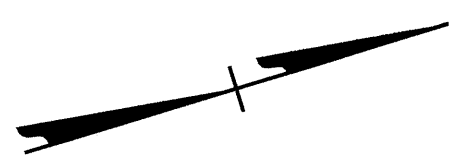

29-AUG-2007 13:24
 \\dot\dfsroot\proj\pprojects-r\2510a\traffic\trafficcontrol\top\pm\2510a-rc-pm09.dgn
 jrspeance AI WZTC224101

APPROVED: *[Signature]* DATE: 9/11/07

SEAL

PAVEMENT MARKINGS

SCALE: NONE		REVISIONS	
DATE: 2/05			
DWG. BY: SJS			
DESIGN BY: SJS			
REVIEWED BY: DAP			

CADD FILE

NOTE:

SEE RSD 1250.01 AND 1253.01 FOR LOCATION AND PLACEMENT OF SNOWPLOWABLE PAVEMENT MARKERS

ALL SNOWPLOWABLE PAVEMENT MARKERS ARE ON 80 FT. CENTERS UNLESS OTHERWISE SHOWN ON THE PLANS.

ALL SYMBOLS ARE THERMOPLASTIC UNLESS OTHERWISE LABELLED ON THE PLAN.

SYMBOL SPACING ALONG -L- IS 240 FT. UNLESS OTHERWISE SHOWN ON THE PLANS. SEE PM-1 FOR SCHEDULE

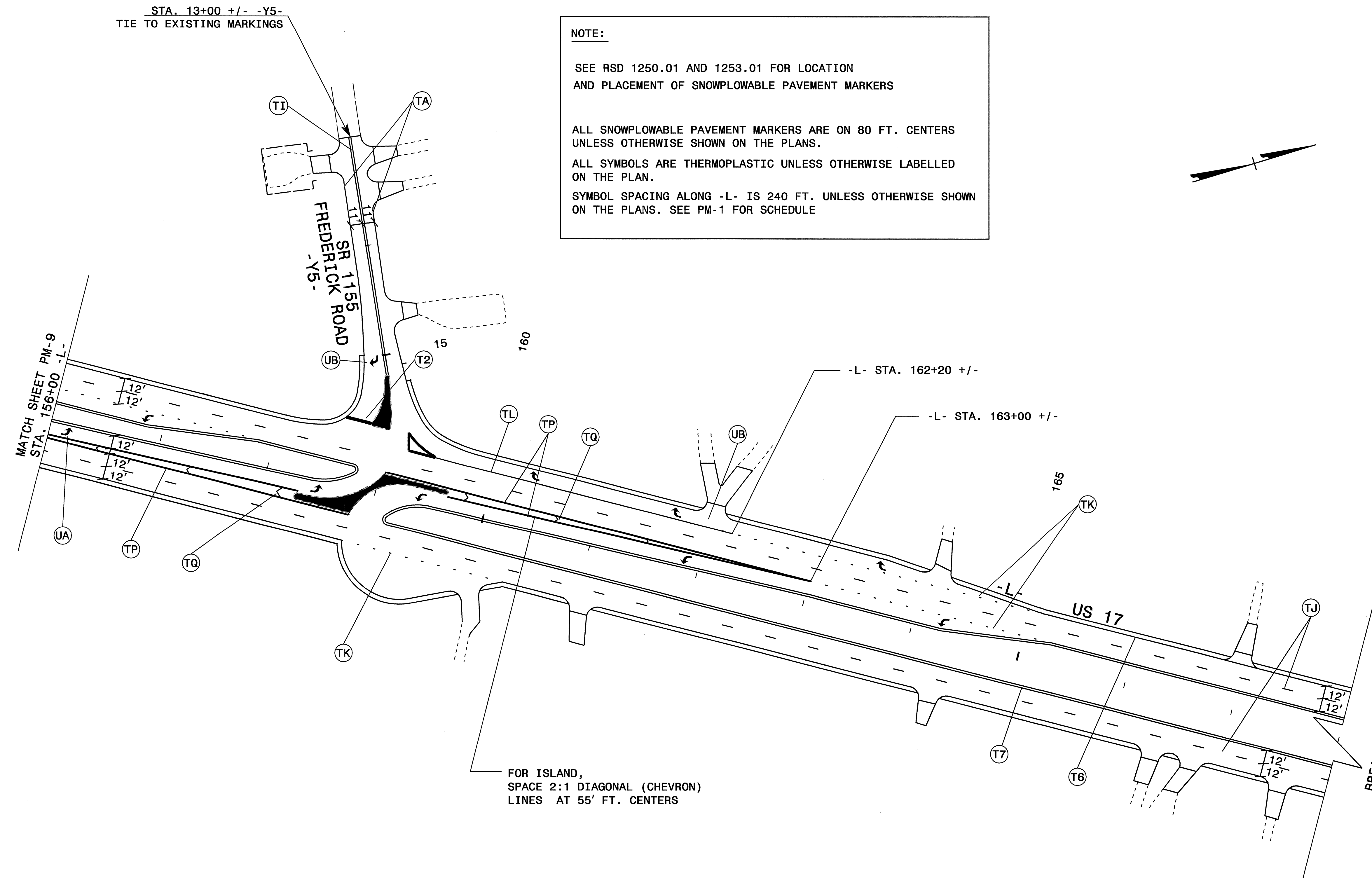
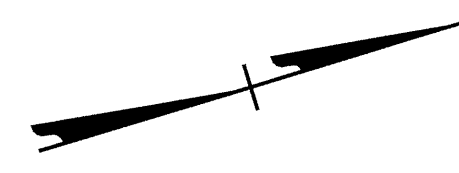

STA. 13+00 +/- -Y5-
TIE TO EXISTING MARKINGS

MATCH SHEET PM-9
STA. 156+00 -L-

SR 1155
FREDERICK ROAD
-Y5-

-L- STA. 162+20 +/-

-L- STA. 163+00 +/-

FOR ISLAND,
SPACE 2:1 DIAGONAL (CHEVRON)
LINES AT 55' FT. CENTERS

BREAKLINE
SEE SHEET PM-11

I:\SEP-2007 14:54
\\dot\dfsroot\01\Proj\TIP\Projects-R\2510A\TrafficControl\Top\PM\S\2510a.tc_pml0.dgn
rspace AT WZTC22410

APPROVED: <i>[Signature]</i> DATE: 9/16/07		<h2>PAVEMENT MARKINGS</h2>	SCALE: NONE		REVISIONS
SEAL			DATE: 2/05		
	DWG. BY: SJS				
	DESIGN BY: SJS				
	REVIEWED BY: DAP				

NOTE:

SEE RSD 1250.01 AND 1253.01 FOR LOCATION AND PLACEMENT OF SNOWPLOWABLE PAVEMENT MARKERS

ALL SNOWPLOWABLE PAVEMENT MARKERS ARE ON 80 FT. CENTERS UNLESS OTHERWISE SHOWN ON THE PLANS.

ALL SYMBOLS ARE THERMOPLASTIC UNLESS OTHERWISE LABELLED ON THE PLAN.

SYMBOL SPACING ALONG -L- IS 240 FT. UNLESS OTHERWISE SHOWN ON THE PLANS. SEE PM-1 FOR SCHEDULE

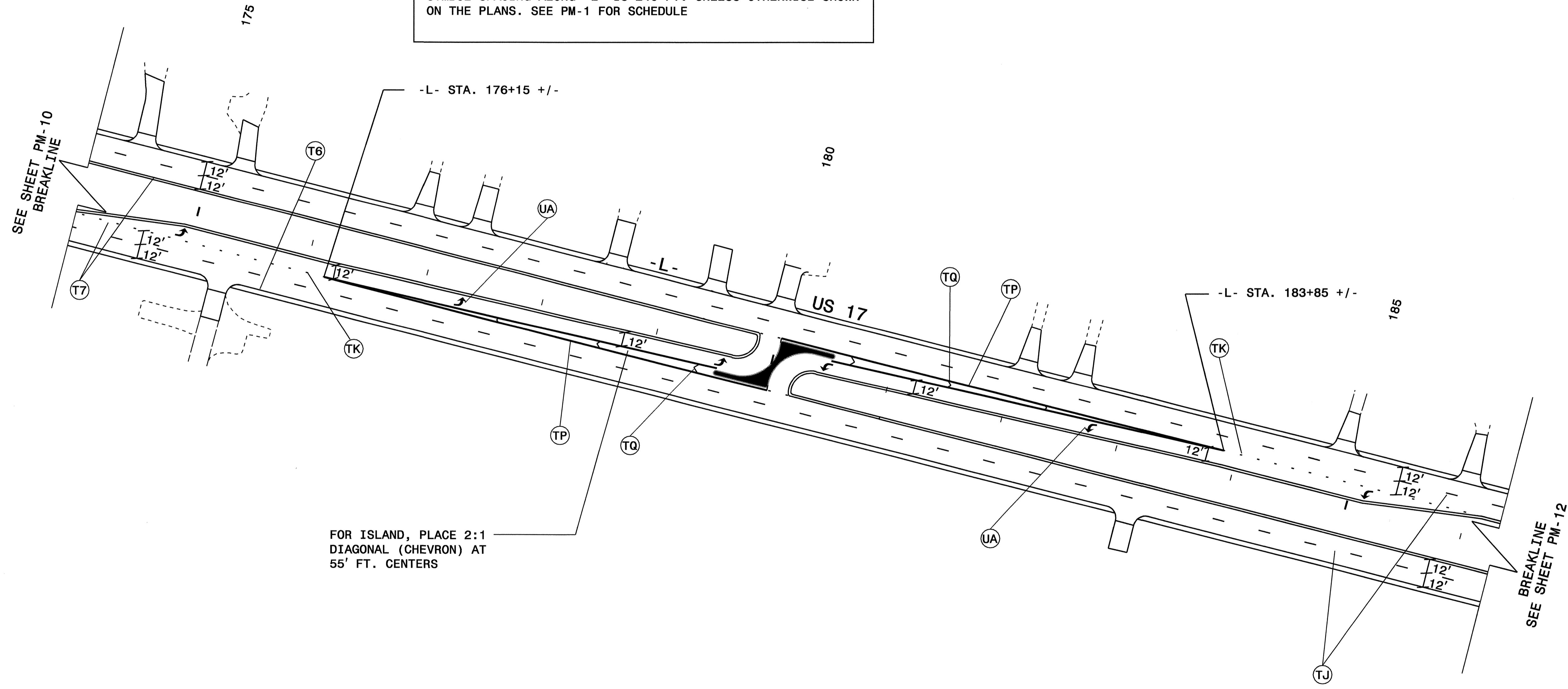

29-AUG-2007 13:25
 \\dot\dfsroot\01\Proj\Ntip\projects-r\2510a\traffic\trafficcontrol\top\pm's\2510a.tc.pml.dgn
 jrspeance AT WZTC224101

APPROVED: <i>[Signature]</i> DATE: 9/1/07												
SEAL					<h2 style="margin: 0;">PAVEMENT MARKINGS</h2>							
SCALE: NONE	DATE: 2/05	<table border="1"> <tr> <th colspan="2">REVISIONS</th> </tr> <tr> <td> </td> <td> </td> </tr> <tr> <td> </td> <td> </td> </tr> <tr> <td> </td> <td> </td> </tr> </table>	REVISIONS								DWG. BY: SJS	
REVISIONS												
		DESIGN BY: SJS										
		REVIEWED BY: DAP										

NOTE:

SEE RSD 1250.01 AND 1253.01 FOR LOCATION AND PLACEMENT OF SNOWPLOWABLE PAVEMENT MARKERS

ALL SNOWPLOWABLE PAVEMENT MARKERS ARE ON 80 FT. CENTERS UNLESS OTHERWISE SHOWN ON THE PLANS.

ALL SYMBOLS ARE THERMOPLASTIC UNLESS OTHERWISE LABELLED ON THE PLAN.

SYMBOL SPACING ALONG -L- IS 240 FT. UNLESS OTHERWISE SHOWN ON THE PLANS. SEE PM-1 FOR SCHEDULE

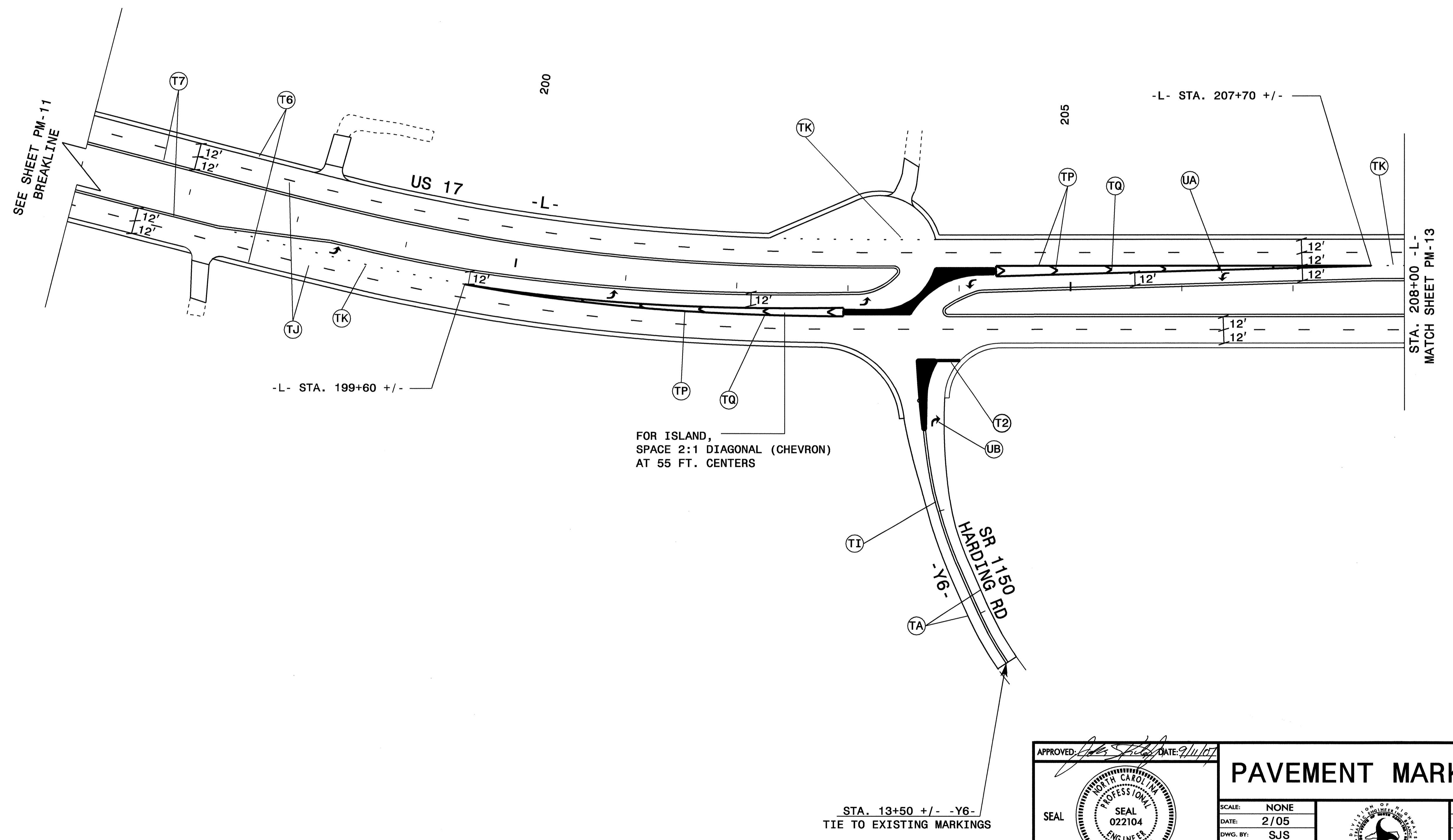
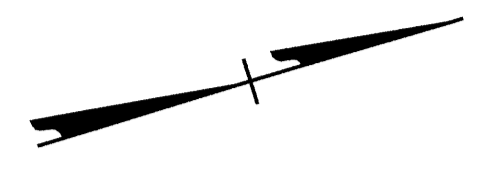

29-AUG-2007 13:25
 \\dot\dfsroot\01\Proj\11\proj\projects-r\2510a\traffic\control\top\pm's\2510a.tc.pm2.dgn
 jr.spence AT WZTC22410J

APPROVED: <i>[Signature]</i> DATE: 9/14/07		<h2>PAVEMENT MARKINGS</h2>					
	SCALE: NONE						
	DATE: 2/05	REVISIONS					
	DWG. BY: SJS DESIGN BY: SJS REVIEWED BY: DAP	<table border="1"> <tr><td> </td><td> </td></tr> <tr><td> </td><td> </td></tr> <tr><td> </td><td> </td></tr> </table>					

NOTE:

SEE RSD 1250.01 AND 1253.01 FOR LOCATION AND PLACEMENT OF SNOWPLOWABLE PAVEMENT MARKERS

ALL SNOWPLOWABLE PAVEMENT MARKERS ARE ON 80 FT. CENTERS UNLESS OTHERWISE SHOWN ON THE PLANS.

ALL SYMBOLS ARE THERMOPLASTIC UNLESS OTHERWISE LABELLED ON THE PLAN.

SYMBOL SPACING ALONG -L- IS 240 FT. UNLESS OTHERWISE SHOWN ON THE PLANS. SEE PM-1 FOR SCHEDULE

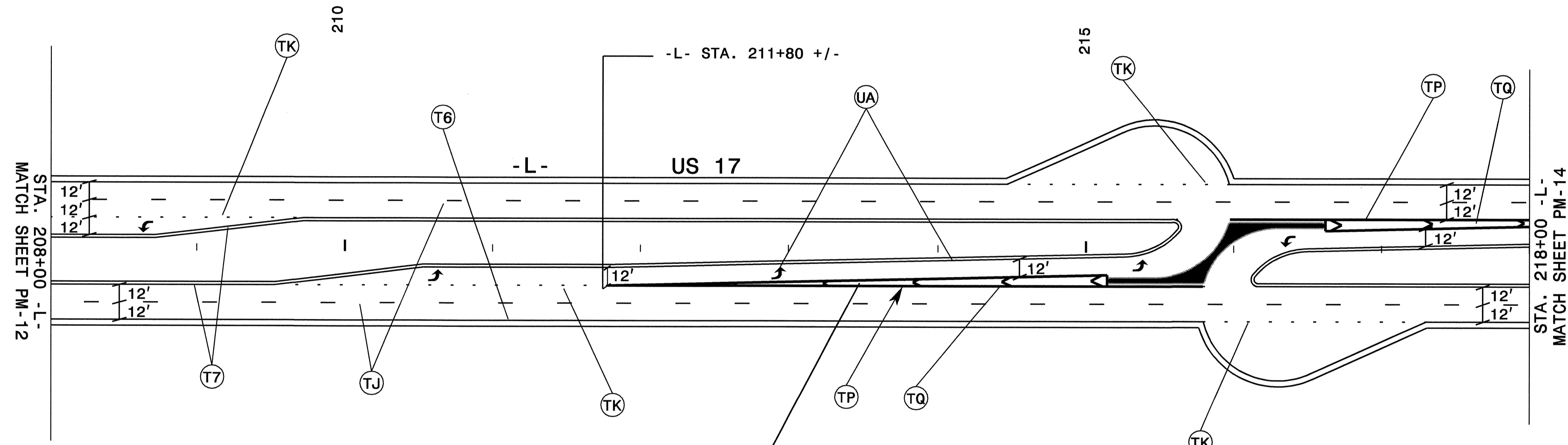
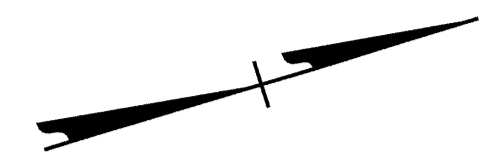

FOR ISLAND, PLACE 2:1 DIAGONAL (CHEVRON) AT 55' FT. CENTERS.

I:\SEP-2007\1456
 \Dof\cifs\root01\Proj\TIP\Projects-R\R2510A\TrafficControl\Top\PM'S\12510a.tc-pm13.dgn
 JR-spence AT WZTC22410

APPROVED: <i>[Signature]</i> DATE: 9/11/07		PAVEMENT MARKINGS	
SCALE:	NONE		REVISIONS
DATE:	2/05		
DWG. BY:	SJS		
DESIGN BY:	SJS		
REVIEWED BY:	DAP		

NOTE:

SEE RSD 1250.01 AND 1253.01 FOR LOCATION AND PLACEMENT OF SNOWPLOWABLE PAVEMENT MARKERS

ALL SNOWPLOWABLE PAVEMENT MARKERS ARE ON 80 FT. CENTERS UNLESS OTHERWISE SHOWN ON THE PLANS.

ALL SYMBOLS ARE THERMOPLASTIC UNLESS OTHERWISE LABELLED ON THE PLAN.

SYMBOL SPACING ALONG -L- IS 240 FT. UNLESS OTHERWISE SHOWN ON THE PLANS. SEE PM-1 FOR SCHEDULE

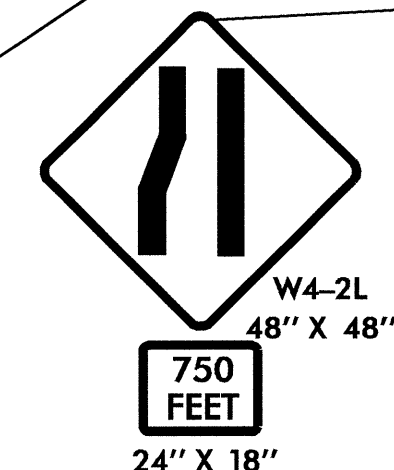
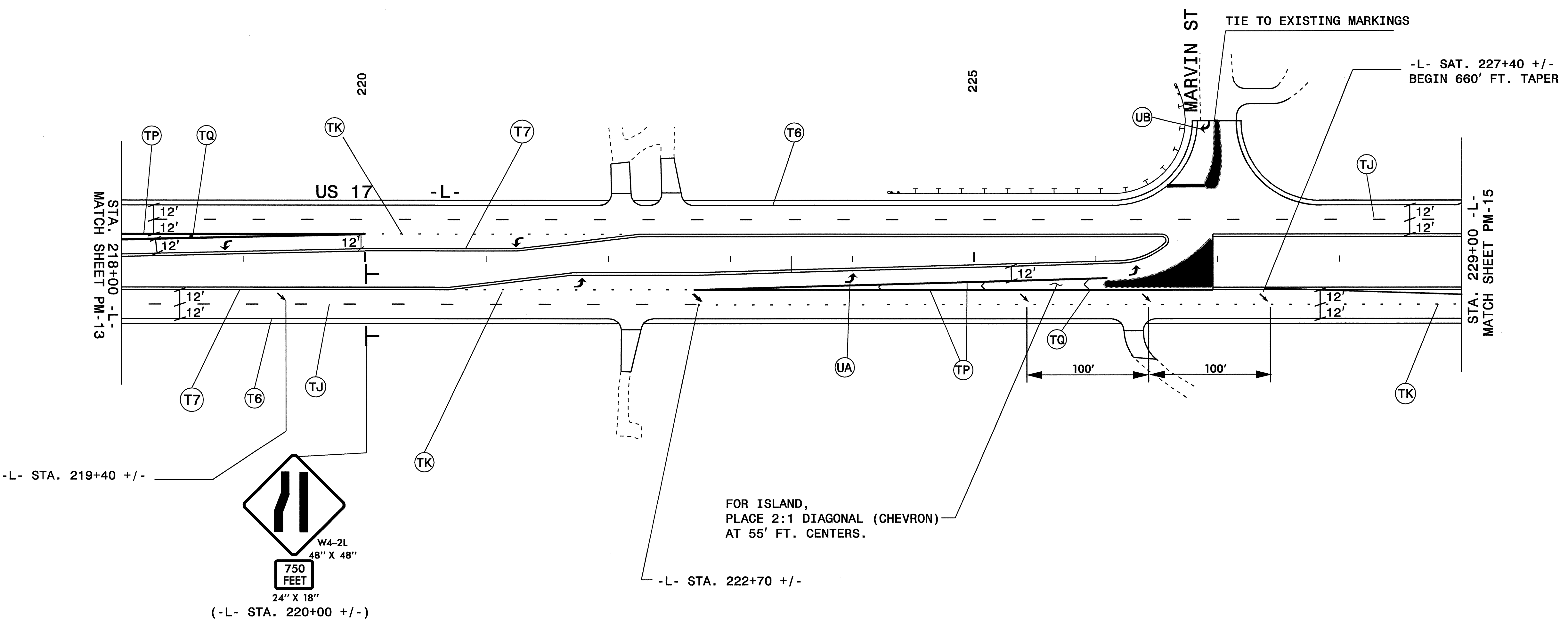
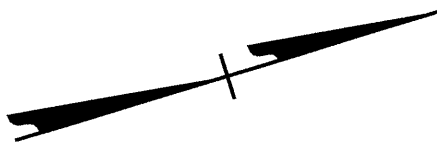

(-L- STA. 220+00 +/-)

29-AUG-2007 13:26 \\dot\dfsroot\01\Projects-r\2510a\traffic\trafficcontrol\top\pm\5\2510a-rc-pm14.dgn
jrspence AT WZTC22401

APPROVED: DATE: 2/16/05	PAVEMENT MARKINGS									
SEAL			SCALE: NONE							
	DATE: 2/05	<table border="1"> <thead> <tr> <th colspan="2">REVISIONS</th> </tr> </thead> <tbody> <tr> <td> </td> <td> </td> </tr> <tr> <td> </td> <td> </td> </tr> <tr> <td> </td> <td> </td> </tr> </tbody> </table>	REVISIONS							
	REVISIONS									
DWG. BY: SJS	DESIGN BY: SJS									
REVIEWED BY: DAP	CADD FILE									

