

09/08/99

See Sheet 1-A For Index of Sheets  
See Sheet 1-B For Conventional Symbols

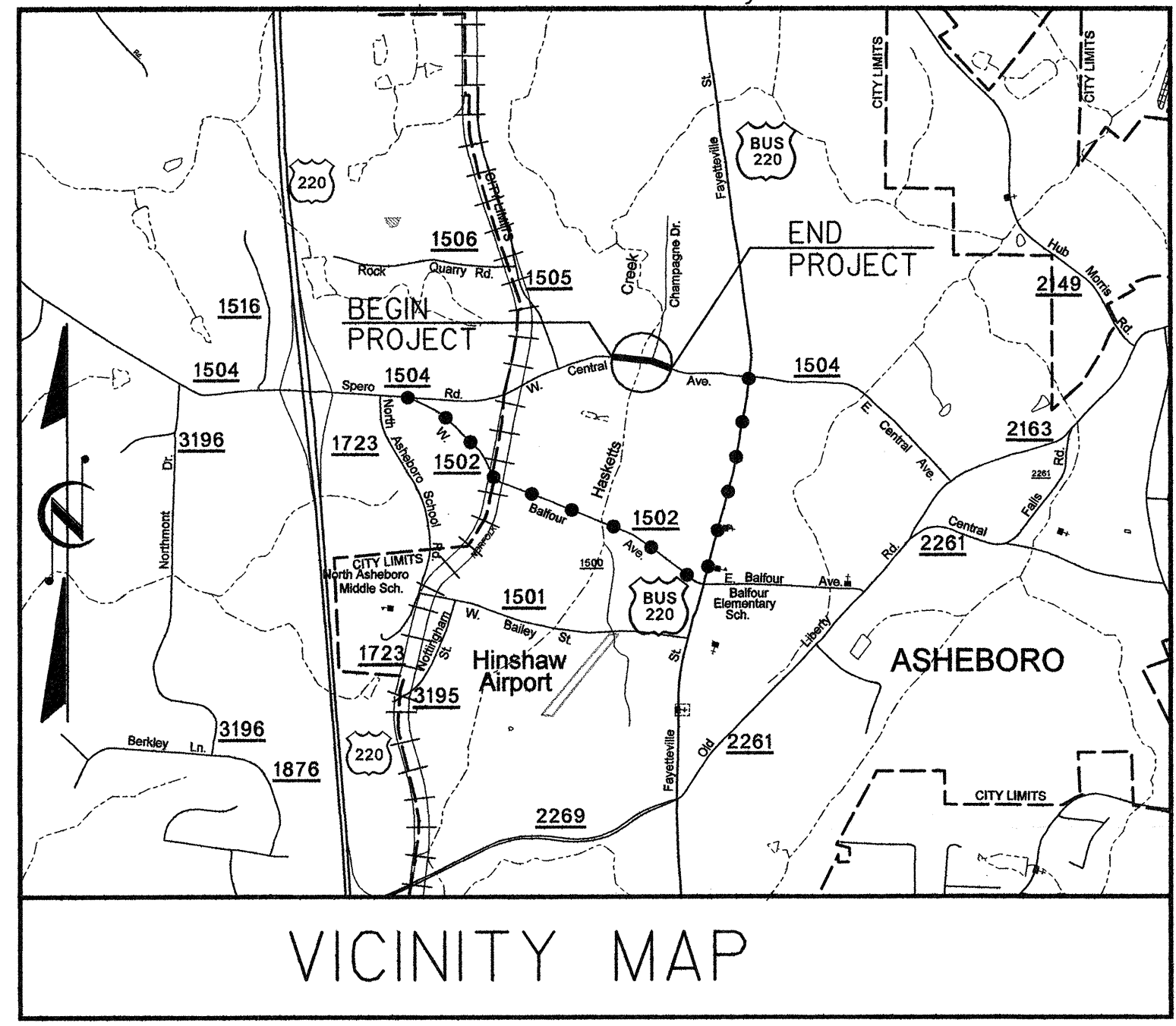

●●●●● DENOTES OFF-SITE DETOUR

STATE OF NORTH CAROLINA  
DIVISION OF HIGHWAYS

**RANDOLPH COUNTY**

**LOCATION: BRIDGE NO. 71 OVER HASKETTS CREEK  
ON SR 1504 IN ASHEBORO**

**TYPE OF WORK: GRADING, DRAINAGE, PAVING, & STRUCTURE**

STATE	STATE PROJECT REFERENCE NO.	SHEET NO.	TOTAL SHEETS
N.C.	B-4243	1	
WBS NO.	F.A. PROJ. NO.	DESCRIPTION	
33586.1.1	BRSTP-1504(8)	P.E.	
33586.2.1	BRSTP-1504(8)	R / W & UTIL.	
33586.3.1	BRSTP-1504(8)	CONSTRUCTION	

**TIP PROJECT: B-4243**  
**CONTRACT: C201680**

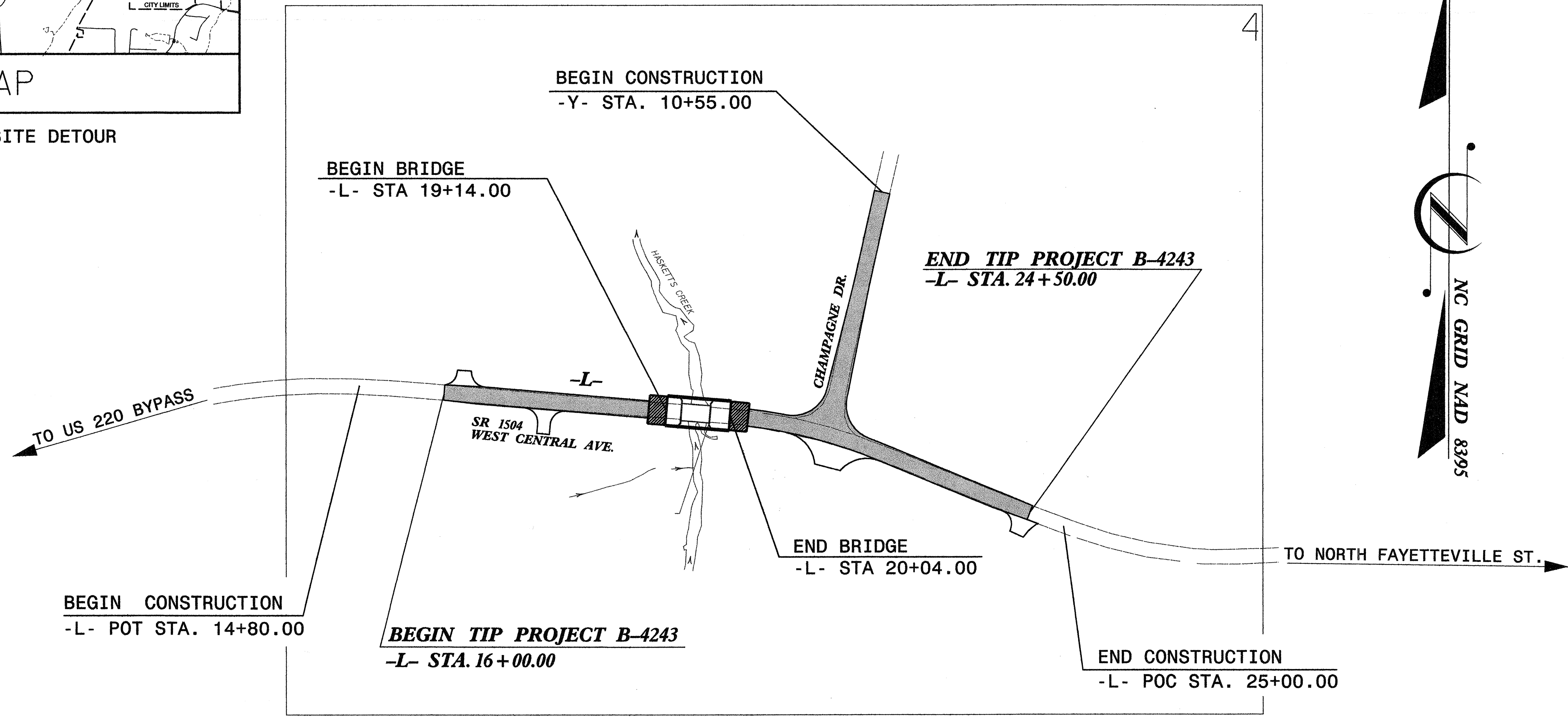

NCDOT CONTACT: CATHY HOUSER, P.E.  
ROADWAY DESIGN - ENGINEERING COORDINATION

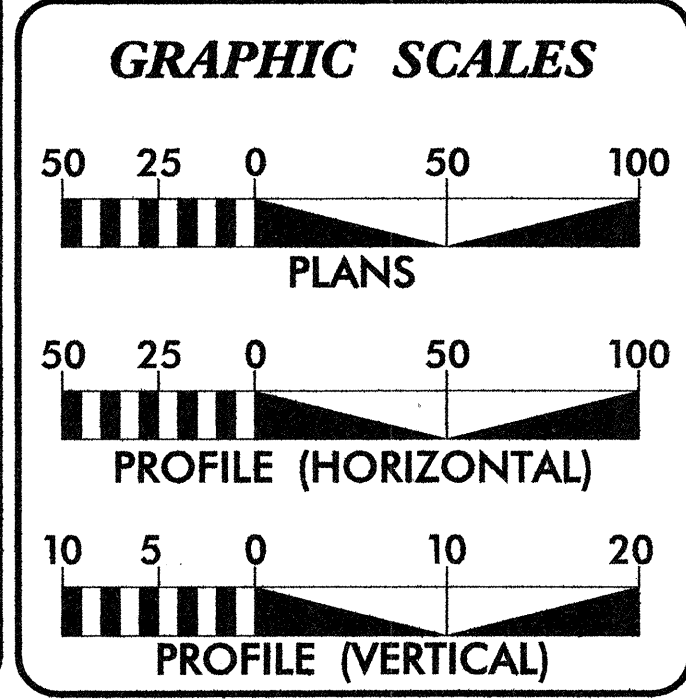

**DESIGN DATA**

ADT (2007) = 6,870  
ADT (2027) = 12,570

DHV = 12 %  
D = 55 %  
T = 3 %  
V = 40 MPH

(TTST = 1% + DUALS = 2%)

**PROJECT LENGTH**

LENGTH ROADWAY TIP PROJECT B-4243	=	0.144 MI.
LENGTH STRUCTURES TIP PROJECT B-4243	=	0.017 MI.
TOTAL LENGTH OF TIP PROJECT B-4243	=	0.161 MI.

Prepared in the Office of:  
**KO & ASSOCIATES, P.C.**  
Consulting Engineers  
1011 Schaub Dr. Suite 202 Raleigh NC 27606  
(919) 851-6066

2006 STANDARD SPECIFICATIONS

RIGHT OF WAY DATE:  
SEPTEMBER 15, 2006

LETTING DATE:  
SEPTEMBER 18, 2007

MICHAEL A. YOUNG, PE  
PROJECT ENGINEER

DAVID C. WALLER, PE  
PROJECT DESIGN ENGINEER

HYDRAULICS ENGINEER

W. Herbert Turner, P.E.  
SIGNATURE

ROADWAY DESIGN ENGINEER

Michael A. Young, P.E.  
SIGNATURE

Professional Engineer Seals for W. Herbert Turner and Michael A. Young.

DIVISION OF HIGHWAYS  
STATE OF NORTH CAROLINA

STATE HIGHWAY DESIGN ENGINEER

cut miller  
P.E.

5/7/2007 R:\Roadway\Proj\B4243\_Rdy\_tsh.dgn KO & Associates, P.C.

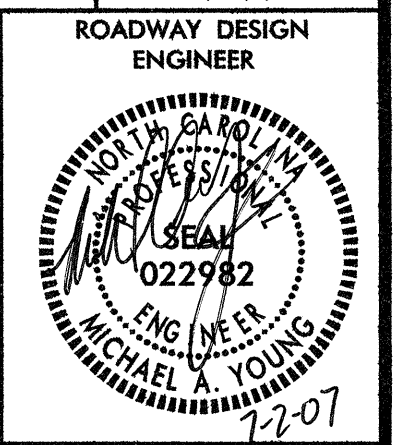

# INDEX OF SHEETS

SHEET NUMBER	SHEET
1	TITLE SHEET
1-A	INDEX OF SHEETS, GENERAL NOTES, AND LIST OF STANDARD DRAWINGS
1-B	CONVENTIONAL SYMBOLS
1-C	<b>SURVEY CONTROL SHEET</b>
2	PAVEMENT SCHEDULE, TYPICAL SECTIONS, AND WEDGING DETAILS
3	SUMMARY OF QUANTITIES
3A THRU 3B	SUMMARY OF EARTHWORK QUANTITIES SUMMARY OF GUARDRAIL AND DRAINAGE QUANTITIES
4	PLAN SHEET
5	PROFILE SHEET
TCP-1 THRU TCP-2	TRAFFIC CONTROL PLANS
EC-1 THRU EC-5	EROSION CONTROL PLANS
UC-1 THRU UC-4	UTILITY CONSTRUCTION PLANS
UO-1 THRU UO-2	UTILITIES BY OTHER PLANS
X-1A	CROSS-SECTION SUMMARY SHEET
X-1 THRU X-6	CROSS-SECTIONS
S-1 THRU S-25	STRUCTURE PLANS

# GENERAL NOTES:

2006 SPECIFICATIONS  
EFFECTIVE: 07-18-06  
REVISED: 07-18-06

**GRADE LINE:**  
GRADING AND SURFACING:  
THE GRADE LINES SHOWN DENOTE THE FINISHED ELEVATION OF THE PROPOSED SURFACING AT GRADE POINTS SHOWN ON THE TYPICAL SECTIONS. GRADE LINES MAY BE ADJUSTED AT THEIR BEGINNING AND ENDING AND AT STRUCTURES AS DIRECTED BY THE ENGINEER IN ORDER TO SECURE A PROPER TIE-IN.

**CLEARING:**  
CLEARING ON THIS PROJECT SHALL BE PERFORMED TO THE LIMITS ESTABLISHED BY METHOD II.

**SUPERELEVATION:**  
ALL CURVES ON THIS PROJECT SHALL BE SUPERELEVATED IN ACCORDANCE WITH STD. NO. 225.04 USING THE RATE OF SUPERELEVATION AND RUNOFF SHOWN ON THE PLANS. SUPERELEVATION IS TO BE REVOLVED ABOUT THE GRADE POINTS SHOWN ON THE TYPICAL SECTIONS.

**SHOULDER CONSTRUCTION:**  
ASPHALT, EARTH, AND CONCRETE SHOULDER CONSTRUCTION ON THE HIGH SIDE OF SUPERELEVATED CURVES SHALL BE IN ACCORDANCE WITH STD. NO. 560.01.

**SIDE ROADS:**  
THE CONTRACTOR WILL BE REQUIRED TO DO ALL NECESSARY WORK TO PROVIDE SUITABLE CONNECTIONS WITH ALL ROADS, STREETS, AND DRIVES ENTERING THIS PROJECT. THIS WORK WILL BE PAID FOR AT THE CONTRACT UNIT PRICE FOR THE PARTICULAR ITEMS INVOLVED.

**DRIVEWAYS:**  
DRIVEWAYS SHALL BE CONSTRUCTED IN ACCORDANCE WITH STD. 848.02 USING 3' RADIUS OR RADIUS AS SHOWN ON THE PLANS. LOCATIONS OF DRIVES WILL BE AS SHOWN ON THE PLANS OR AS DIRECTED BY THE ENGINEER.

**STREET TURNOUT:**  
STREET RETURNS SHALL BE CONSTRUCTED IN ACCORDANCE WITH STD. NO. 848.04 USING THE RADIUS NOTED ON PLANS.

**GUARDRAIL:**  
THE GUARDRAIL LOCATIONS SHOWN ON THE PLANS MAY BE ADJUSTED DURING CONSTRUCTION AS DIRECTED BY THE ENGINEER. THE CONTRACTOR SHOULD CONSULT WITH THE ENGINEER PRIOR TO ORDERING GUARDRAIL MATERIAL.

**TEMPORARY SHORING:**  
SHORING REQUIRED FOR THE MAINTENANCE OF TRAFFIC WILL BE PAID FOR AS "EXTRA WORK" IN ACCORDANCE WITH SECTION 104-7.

**SUBSURFACE PLANS:**  
NO SUBSURFACE PLANS ARE AVAILABLE ON THIS PROJECT. THE CONTRACTOR SHOULD MAKE HIS OWN INVESTIGATION AS TO THE SUBSURFACE CONDITIONS.

**END BENTS:**  
THE ENGINEER SHALL CHECK THE STRUCTURE END BENT PLANS, DETAILS, AND CROSS-SECTION PRIOR TO SETTING OF THE SLOPE STAKES FOR THE EMBANKMENT OR EXCAVATION APPROACHING A BRIDGE.

**UTILITIES:**  
UTILITY OWNERS ON THIS PROJECT ARE: EMBARK, PIEDMONT NATURAL GAS AND PROGRESS ENERGY.  
  
ANY RELOCATION OF EXISTING UTILITIES WILL BE ACCOMPLISHED BY OTHERS, EXCEPT AS SHOWN ON THE PLANS.

**RIGHT-OF-WAY MARKERS:**  
ALL RIGHT-OF-WAY MARKERS ON THIS PROJECT SHALL BE PLACED BY CONTRACT.

# 2006 ROADWAY STANDARD DRAWINGS

EFF. 07-18-06  
REV. 01-02-07

The following Roadway Standards as appear in "Roadway Standard Drawings" Highway Design Branch - N. C. Department of Transportation - Raleigh, N. C., Dated July 18, 2006 are applicable to this project and by reference hereby are considered a part of these plans:

STD.NO.	TITLE
<b>DIVISION 2 - EARTHWORK</b>	
200.02	Method of Clearing - Method II
225.02	Guide for Grading Subgrade - Secondary and Local
225.04	Method of Obtaining Superelevation - Two Lane Pavement
225.06	Method of Grading Sight Distance at Intersections
<b>DIVISION 3 - PIPE CULVERTS</b>	
300.01	Method of Pipe Installation - Method 'A'
310.10	Driveway Pipe Construction
<b>DIVISION 4 - MAJOR STRUCTURES</b>	
422.10	Reinforced Bridge Approach Fills
<b>DIVISION 5 - SUBGRADE, BASES AND SHOULDERS</b>	
560.01	Method of Shoulder Construction - High Side of Superelevated Curve - Method I
<b>DIVISION 6 - ASPHALT BASES AND PAVEMENTS</b>	
654.01	Pavement Repairs
<b>DIVISION 8 - INCIDENTALS</b>	
806.01	Concrete Right-of-Way Marker
840.18	Concrete Grated Drop Inlet Type 'B' - 12" thru 36" Pipe
840.27	Brick Grated Drop Inlet Type 'B' - 12" thru 36" Pipe
840.29	Frames and Narrow Slot Flat Grates
840.45	Precast Drainage Structure
840.71	Concrete and Brick Pipe Plug
840.72	Pipe Collar
846.01	Concrete Curb, Gutter and Curb & Gutter
846.04	Drop Inlet Installation in Shoulder Berm Gutter
848.02	Driveway Turnout - Radius Type
848.04	Street Turnout
862.01	Guardrail Placement
862.02	Guardrail Installation
862.03	Structure Anchor Units
876.02	Guide for Rip Rap at Pipe Outlets

10/25/05







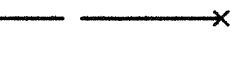

Note: Not to Scale

\*S.U.E. = Subsurface Utility Engineering





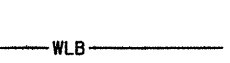
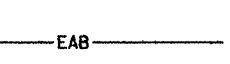
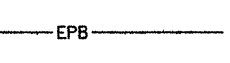





STATE OF NORTH CAROLINA  
DIVISION OF HIGHWAYS

# CONVENTIONAL PLAN SHEET SYMBOLS











### BOUNDARIES AND PROPERTY:

State Line	_____
County Line	_____
Township Line	_____
City Line	_____
Reservation Line	_____
Property Line	_____
Existing Iron Pin	_____ 
Property Corner	_____ 
Property Monument	_____ 
Parcel/Sequence Number	_____ 
Existing Fence Line	_____ 
Proposed Woven Wire Fence	_____ 
Proposed Chain Link Fence	_____ 
Proposed Barbed Wire Fence	_____ 
Existing Wetland Boundary	_____ 
Proposed Wetland Boundary	_____ 
Existing Endangered Animal Boundary	_____ 
Existing Endangered Plant Boundary	_____ 





### BUILDINGS AND OTHER CULTURE:

Gas Pump Vent or U/G Tank Cap	_____ 
Sign	_____ 
Well	_____ 
Small Mine	_____ 
Foundation	_____ 
Area Outline	_____ 
Cemetery	_____ 
Building	_____ 
School	_____ 
Church	_____ 
Dam	_____ 





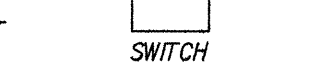





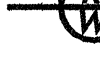

### HYDROLOGY:

Stream or Body of Water	_____
Hydro, Pool or Reservoir	_____ 
Jurisdictional Stream	_____ 
Buffer Zone 1	_____ 
Buffer Zone 2	_____ 
Flow Arrow	_____ 
Disappearing Stream	_____ 
Spring	_____ 
Swamp Marsh	_____ 
Proposed Lateral, Tail, Head Ditch	_____ 
False Sump	_____ 



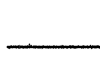









### RAILROADS:

Standard Gauge	_____ 
RR Signal Milepost	_____ 
Switch	_____ 
RR Abandoned	_____ 
RR Dismantled	_____ 



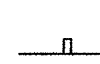



### RIGHT OF WAY:

Baseline Control Point	_____ 
Existing Right of Way Marker	_____ 
Existing Right of Way Line	_____ 
Proposed Right of Way Line	_____ 
Proposed Right of Way Line with Iron Pin and Cap Marker	_____ 
Proposed Right of Way Line with Concrete or Granite Marker	_____ 
Existing Control of Access	_____ 
Proposed Control of Access	_____ 
Existing Easement Line	_____ 
Proposed Temporary Construction Easement	_____ 
Proposed Temporary Drainage Easement	_____ 
Proposed Permanent Drainage Easement	_____ 
Proposed Permanent Utility Easement	_____ 



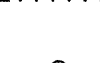



### ROADS AND RELATED FEATURES:

Existing Edge of Pavement	_____ 
Existing Curb	_____ 
Proposed Slope Stakes Cut	_____ 
Proposed Slope Stakes Fill	_____ 
Proposed Wheel Chair Ramp	_____ 
Curb Cut for Future Wheel Chair Ramp	_____ 
Existing Metal Guardrail	_____ 
Proposed Guardrail	_____ 
Existing Cable Guiderail	_____ 
Proposed Cable Guiderail	_____ 
Equality Symbol	_____ 
Pavement Removal	_____ 

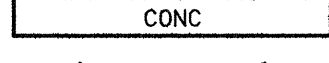
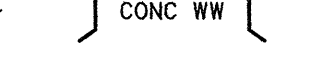
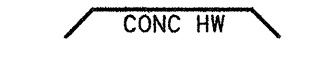



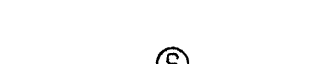
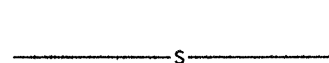





### VEGETATION:

Single Tree	_____ 
Single Shrub	_____ 
Hedge	_____ 
Woods Line	_____ 
Orchard	_____ 
Vineyard	_____ 





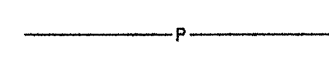
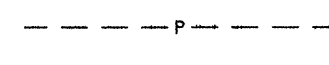



### EXISTING STRUCTURES:

MAJOR:	
Bridge, Tunnel or Box Culvert	_____ 
Bridge Wing Wall, Head Wall and End Wall	_____ 
MINOR:	
Head and End Wall	_____ 
Pipe Culvert	_____ 
Footbridge	_____ 
Drainage Box: Catch Basin, DI or JB	_____ 
Paved Ditch Gutter	_____ 
Storm Sewer Manhole	_____ 
Storm Sewer	_____ 

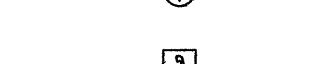



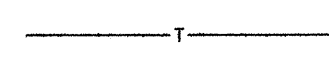
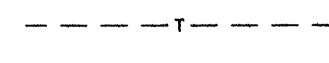
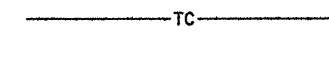
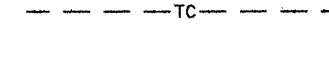
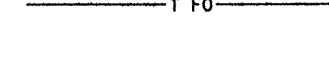
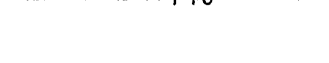

### UTILITIES:

POWER:	
Existing Power Pole	_____ 
Proposed Power Pole	_____ 
Existing Joint Use Pole	_____ 
Proposed Joint Use Pole	_____ 
Power Manhole	_____ 
Power Line Tower	_____ 
Power Transformer	_____ 
U/G Power Cable Hand Hole	_____ 
H-Frame Pole	_____ 
Recorded U/G Power Line	_____ 
Designated U/G Power Line (S.U.E.*)	_____ 







### TELEPHONE:

Existing Telephone Pole	_____ 
Proposed Telephone Pole	_____ 
Telephone Manhole	_____ 
Telephone Booth	_____ 
Telephone Pedestal	_____ 
Telephone Cell Tower	_____ 
U/G Telephone Cable Hand Hole	_____ 
Recorded U/G Telephone Cable	_____ 
Designated U/G Telephone Cable (S.U.E.*)	_____ 
Recorded U/G Telephone Conduit	_____ 
Designated U/G Telephone Conduit (S.U.E.*)	_____ 
Recorded U/G Fiber Optics Cable	_____ 
Designated U/G Fiber Optics Cable (S.U.E.*)	_____ 



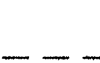
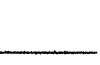
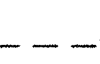

### WATER:

Water Manhole	_____ 
Water Meter	_____ 
Water Valve	_____ 
Water Hydrant	_____ 
Recorded U/G Water Line	_____ 
Designated U/G Water Line (S.U.E.*)	_____ 
Above Ground Water Line	_____ 





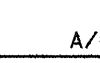

### TV:

TV Satellite Dish	_____ 
TV Pedestal	_____ 
TV Tower	_____ 
U/G TV Cable Hand Hole	_____ 
Recorded U/G TV Cable	_____ 
Designated U/G TV Cable (S.U.E.*)	_____ 
Recorded U/G Fiber Optic Cable	_____ 
Designated U/G Fiber Optic Cable (S.U.E.*)	_____ 



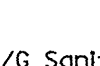







### GAS:

Gas Valve	_____ 
Gas Meter	_____ 
Recorded U/G Gas Line	_____ 
Designated U/G Gas Line (S.U.E.*)	_____ 
Above Ground Gas Line	_____ 

### SANITARY SEWER:

Sanitary Sewer Manhole	_____ 
Sanitary Sewer Cleanout	_____ 
U/G Sanitary Sewer Line	_____ 
Above Ground Sanitary Sewer	_____ 
Recorded SS Forced Main Line	_____ 
Designated SS Forced Main Line (S.U.E.*)	_____ 

### MISCELLANEOUS:

Utility Pole	_____ 
Utility Pole with Base	_____ 
Utility Located Object	_____ 
Utility Traffic Signal Box	_____ 
Utility Unknown U/G Line	_____ 
U/G Tank; Water, Gas, Oil	_____ 
A/G Tank; Water, Gas, Oil	_____ 
U/G Test Hole (S.U.E.*)	_____ 
Abandoned According to Utility Records	_____ 
End of Information	_____ 

6/2/99

# SURVEY CONTROL SHEET B-4243

PROJECT REFERENCE NO. <b>B-4243</b>	SHEET NO. <b>IC</b>
Location and Surveys	

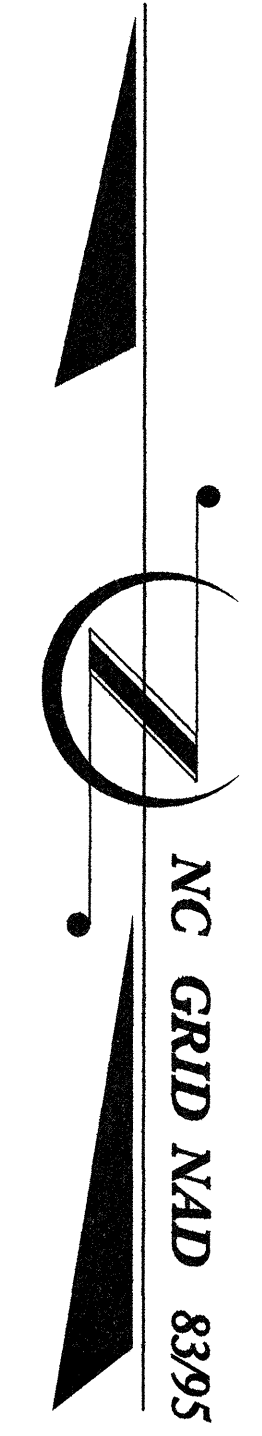

BL POINT	DESC.	NORTH	EAST	ELEVATION	L STATION	OFFSET
1	B4243-1	730494.0970	1758939.3760	698.73	13+14.74	20.61 LT
101	BL-101	730424.9450	1759609.8840	659.62	19+85.83	16.59 RT
102	BL-102	730225.4700	1760280.8910	688.58	26+89.66	17.79 RT

.....  
 BM \*1 ELEVATION = 703.88  
 N 730491 E 1758878  
 L STATION 12+56.28 LEFT  
 .....

.....  
 BM \*2 ELEVATION = 668.79  
 N 730291 E 1759637  
 L STATION 20+29.147 RIGHT  
 .....

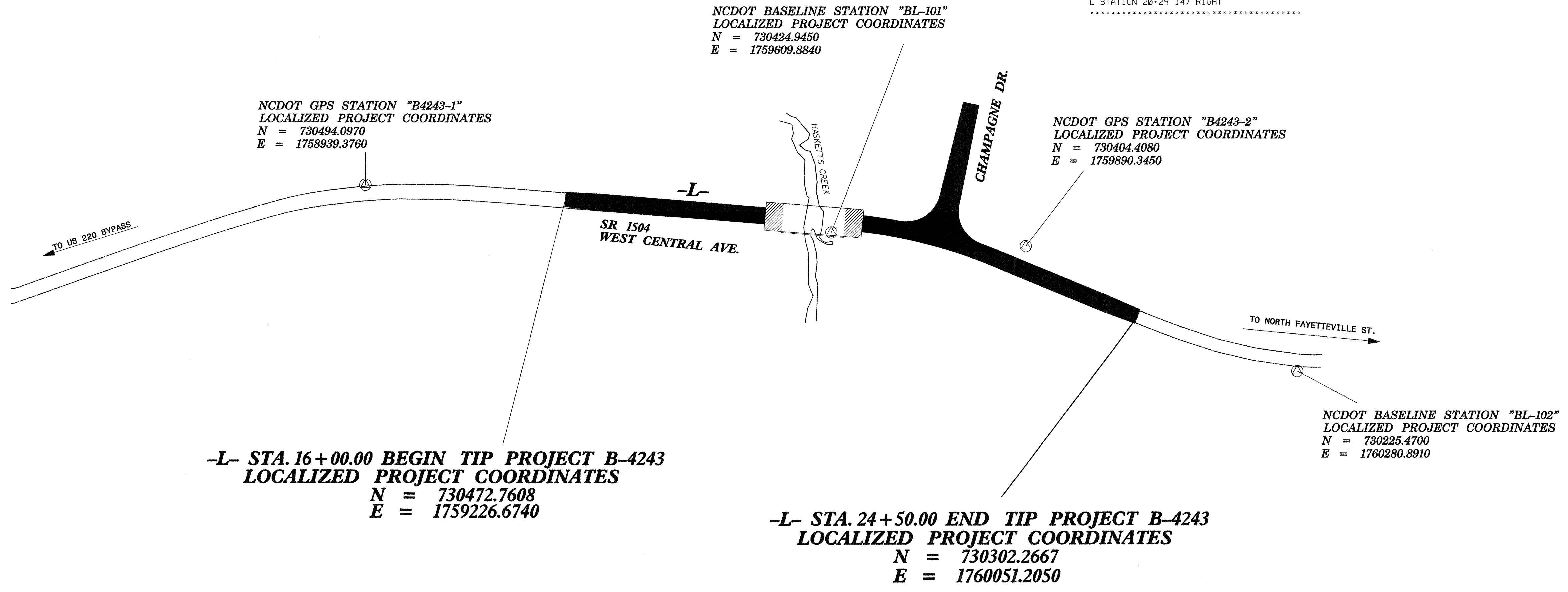

**DATUM DESCRIPTION**

THE LOCALIZED COORDINATE SYSTEM DEVELOPED FOR THIS PROJECT IS BASED ON THE STATE PLANE COORDINATES ESTABLISHED BY NCDOT FOR MONUMENT "B4243-1" WITH NAD 83/95 STATE PLANE GRID COORDINATES OF NORTHING: 730494.097(f1) EASTING: 1758939.376(f1) THE AVERAGE COMBINED GRID FACTOR USED ON THIS PROJECT (GROUND TO GRID) IS: 0.999883100 THE N.C. LAMBERT GRID BEARING AND LOCALIZED HORIZONTAL GROUND DISTANCE FROM "B4243-1" TO -L- STATION 16+00.00 IS S 85°45'09.8" E 288.09'

ALL LINEAR DIMENSIONS ARE LOCALIZED HORIZONTAL DISTANCES VERTICAL DATUM USED IS NAVD 88

- NOTES:**
- THE CONTROL DATA FOR THIS PROJECT CAN BE FOUND ELECTRONICALLY BY SELECTING PROJECT CONTROL DATA AT:  
[HTTP://WWW.DOH.DOT.STATE.NC.US/PRECONSTRUCT/HIGHWAY/LOCATION/PROJECT/](http://www.doh.dot.state.nc.us/preconstruct/highway/location/project/)  
THE FILES TO BE FOUND ARE AS FOLLOWS:  
B-4243\_LS\_CONTROL\_051103.TXT
- SITE CALIBRATION INFORMATION HAS NOT BEEN PROVIDED FOR THIS PROJECT. IF FURTHER INFORMATION IS NEEDED, PLEASE CONTACT THE LOCATION AND SURVEYS UNIT.
- © INDICATES GEODETIC CONTROL MONUMENTS USED OR SET FOR HORIZONTAL PROJECT CONTROL BY THE NCDOT LOCATION AND SURVEYS UNIT.  
PROJECT CONTROL ESTABLISHED USING GLOBAL POSITIONING SYSTEM.

NOTE: DRAWING NOT TO SCALE

5/7/2007 8:47:00 AM \\fs1\proj\B4243\ls\_1c\_051103.dgn

6/2/99

PAVEMENT SCHEDULE

C1	PROP. APPROX. 1 1/2" ASPHALT CONCRETE SURFACE COURSE, TYPE S9.5B, AT AN AVERAGE RATE OF 168 LBS. PER SQ. YD.	E1	PROP. APPROX. 4 1/2" ASPHALT CONCRETE BASE COURSE, TYPE B25.0B, AT AN AVERAGE RATE OF 513 LBS. PER SQ. YD.
C2	PROP. APPROX. 3" ASPHALT CONCRETE SURFACE COURSE, TYPE S9.5B, AT AN AVERAGE RATE OF 168 LBS. PER SQ. YD. IN EACH OF TWO LAYERS.	E2	PROP. VAR. DEPTH ASPHALT CONCRETE BASE COURSE, TYPE B25.0B, AT AN AVERAGE RATE OF 114 LBS. PER SQ. YD. PER 1" DEPTH. TO BE PLACED IN LAYERS NOT LESS THAN 3" IN DEPTH OR GREATER THAN 5 1/2" IN DEPTH.
C3	PROP. VAR. DEPTH ASPHALT CONCRETE SURFACE COURSE, TYPE S9.5B, AT AN AVERAGE RATE OF 112 LBS. PER SQ. YD. PER 1" DEPTH. TO BE PLACED IN LAYERS NOT TO EXCEED 2" IN DEPTH.	T	EARTH MATERIAL.
D1	PROP. APPROX. 2 1/2" ASPHALT CONCRETE INTERMEDIATE COURSE, TYPE I19.0B, AT AN AVERAGE RATE OF 285 LBS. PER SQ. YD.	U	EXISTING PAVEMENT.
D2	PROP. VAR. DEPTH ASPHALT CONCRETE INTERMEDIATE COURSE, TYPE I19.0B, AT AN AVERAGE RATE OF 114 LBS. PER SQ. YD. PER 1" DEPTH, TO BE PLACED IN LAYERS NOT LESS THAN 2 1/2" IN DEPTH OR GREATER THAN 4" IN DEPTH.	W	VARIABLE DEPTH ASPHALT PAVEMENT

**KO & ASSOCIATES, P.C.**  
 Consulting Engineers  
 101 SCHAUB DR., SUITE 202 RALEIGH, N.C. 27606  
 (919) 851-6066

PROJECT REFERENCE NO. B-4243	SHEET NO. 2
ROADWAY DESIGN ENGINEER MICHAEL A. YOUNG 022882	PAVEMENT DESIGN ENGINEER CHI CHEN 13368

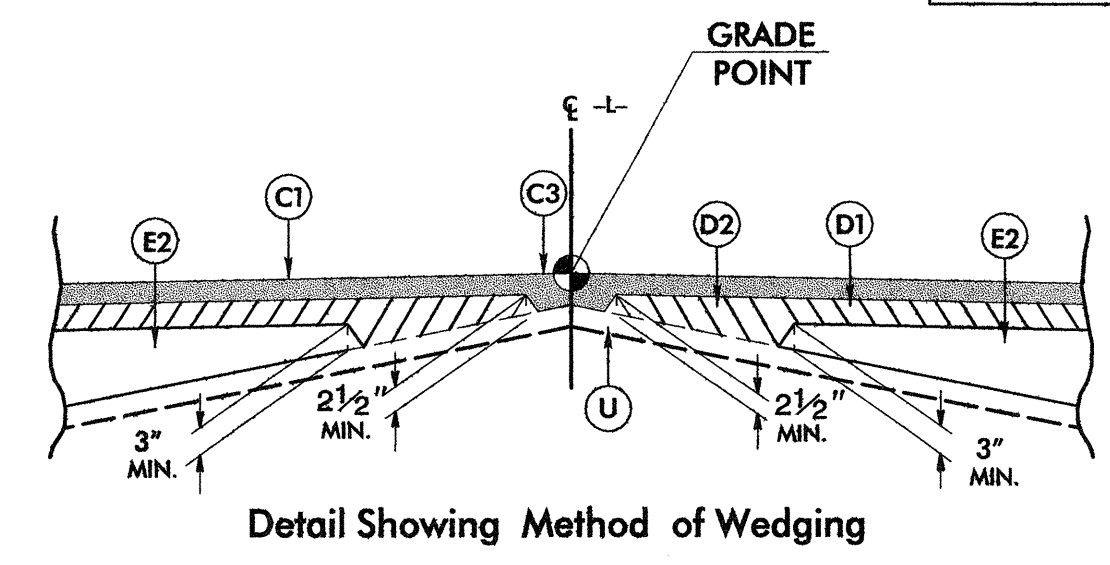

NOTE: PAVEMENT EDGE SLOPES ARE 1:1 UNLESS SHOWN OTHERWISE.

TRANSITION FROM EXISTING TO T.S. NO. 1  
 -L- STA. 16+00.00 TO 16+50.00

USE TYPICAL SECTION NO. 1  
 -L- STA. 16+50.00 TO 17+75.00  
 -L- STA. 21+00.00 TO 24+00.00

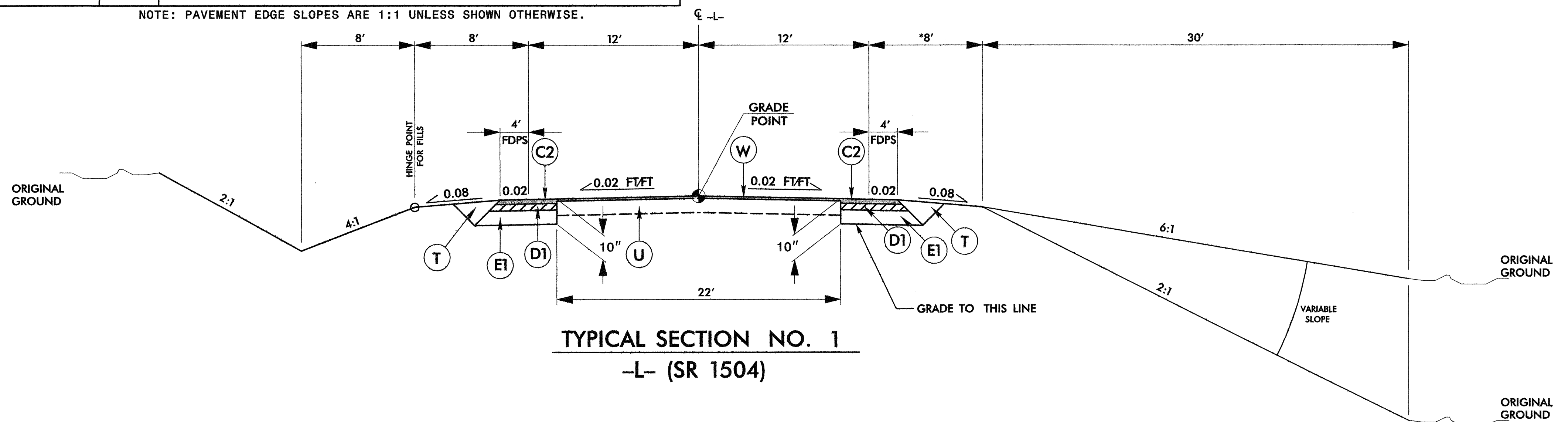

TRANSITION FROM T.S. NO. 1 TO EXISTING  
 -L- STA. 24+00.00 TO 24+50.00

USE TYPICAL SECTION NO. 2  
 -L- STA. 17+75.00 TO 18+89.83 (APPROACH SLAB)  
 -L- STA. 20+28.17 (APPROACH SLAB) TO 21+00.00

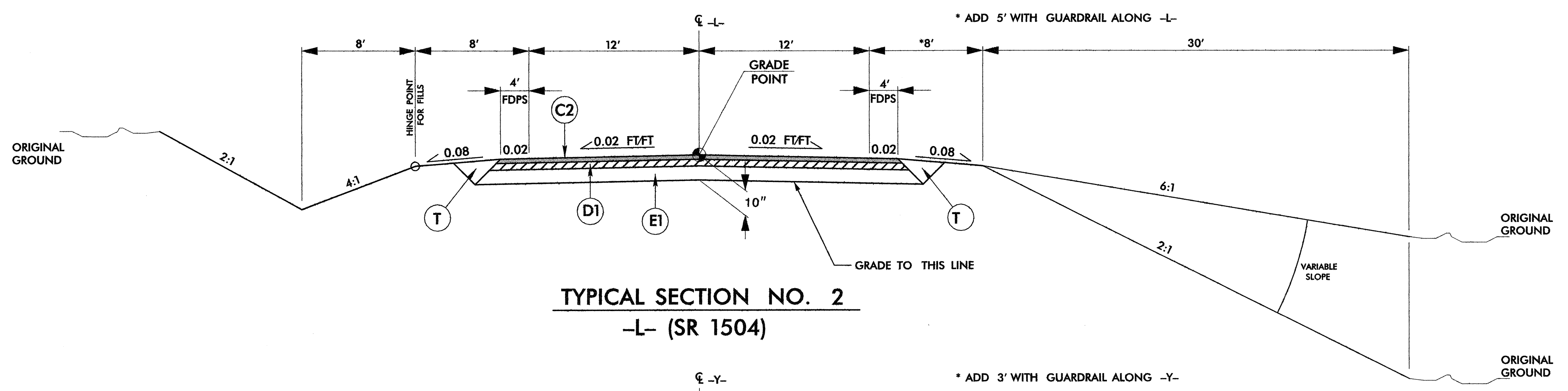

TRANSITION FROM EXISTING TO T.S. NO. 3  
 -Y- STA. 10+55.00 TO 11+00.00

USE TYPICAL SECTION NO. 3  
 -Y- STA. 11+00.00 TO 13+39.81

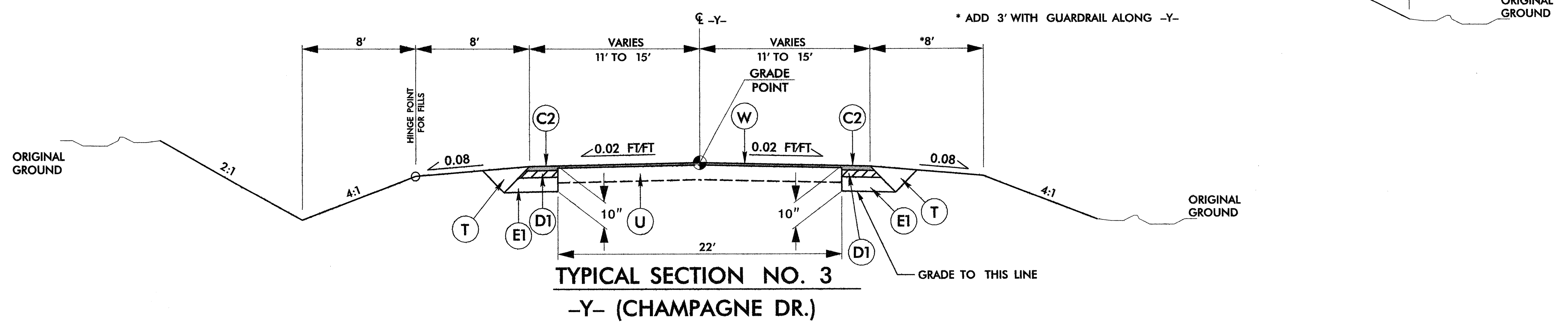

7/2/2007  
 R:\Roadway\Proj\B4243.Rdy-tyr.dgn  
 KO & Associates, P.C.

STATE OF NORTH CAROLINA DIVISION OF HIGHWAYS ROADWAY SUMMARY OF QUANTITIES FOR CONTRACT - C201680									
ItemNumber	Sec #	Quantity	Unit	Description	ItemNumber	Sec #	Quantity	Unit	Description
0000100000-N	800	Lump Sum		MOBILIZATION	5325800000-E	1510	67	LF	8" WATER LINE
0029000000-N	SP	Lump Sum		REINFORCED BRIDGE APPROACH FILL, STATION ***** (19+59.00)	5540000000-E	1515	1	EA	6" VALVE
0050000000-E	226	1	ACR	SUPPLEMENTARY CLEARING & GRUB- BING	5546000000-E	1515	1	EA	8" VALVE
0057000000-E	226	550	CY	UNDERCUT EXCAVATION	5649000000-N	1515	3	EA	RECONNECT WATER METER
0063000000-N	SP	Lump Sum		GRADING	5666000000-E	1515	1	EA	FIRE HYDRANT
0080000000-E	SP	200	TON	CLASS IV SUBGRADE STABILIZA- TION	5691300000-E	1520	107	LF	8" SANITARY GRAVITY SEWER
0106000000-E	230	3,950	CY	BORROW EXCAVATION	5691700000-E	1520	85	LF	18" SANITARY GRAVITY SEWER
0134000000-E	240	260	CY	DRAINAGE DITCH EXCAVATION	5775000000-E	1525	2	EA	4" DIA UTILITY MANHOLE
0195000000-E	265	200	CY	SELECT GRANULAR MATERIAL	5800000000-E	1530	1,056	LF	ABANDON 6" UTILITY PIPE
0196000000-E	270	500	SY	FABRIC FOR SOIL STABILIZATION	5801000000-E	1530	240	LF	ABANDON 8" UTILITY PIPE
0318000000-E	300	85	TON	FOUNDATION CONDITIONING MATE- RIAL, MINOR STRS	5811000000-E	1530	85	LF	ABANDON 18" UTILITY PIPE
0344000000-E	310	84	LF	18" SIDE DRAIN PIPE	5816000000-N	1530	1	EA	ABANDON UTILITY MANHOLE
0366000000-E	310	20	LF	15" RC PIPE CULVERTS, CLASS III	5828000000-N	1530	1	EA	REMOVE UTILITY MANHOLE
0372000000-E	310	4	LF	18" RC PIPE CULVERTS, CLASS III	5871910000-E	1550	40	LF	TRENCHLESS INSTALLATION OF 16" NOT IN SOIL
0378000000-E	310	100	LF	24" RC PIPE CULVERTS, CLASS III	6000000000-E	1605	925	LF	TEMPORARY SILT FENCE
0708000000-E	310	12	LF	15" BIT COAT CS PIPE CULVERTS, TYPE B 0.064" THICK	6006000000-E	1610	205	TON	STONE FOR EROSION CONTROL, CLASS A
0806000000-E	310	2	EA	15" BIT COAT CS PIPE ELBOWS, TYPE B 0.064" THICK (15", 0.064")	6009000000-E	1610	230	TON	STONE FOR EROSION CONTROL, CLASS B
0995000000-E	340	158	LF	PIPE REMOVAL	6012000000-E	1610	135	TON	SEDIMENT CONTROL STONE
1220000000-E	545	100	TON	INCIDENTAL STONE BASE	6015000000-E	1615	1.5	ACR	TEMPORARY MULCHING
1489000000-E	610	1,925	TON	ASPHALT CONC BASE COURSE, TYPE B25.0B	6018000000-E	1620	100	LB	SEED FOR TEMPORARY SEEDING
1498000000-E	610	375	TON	ASPHALT CONC INTERMEDIATE COURSE, TYPE I19.0B	6021000000-E	1620	0.25	TON	FERTILIZER FOR TEMPORARY SEED- ING
1519000000-E	610	600	TON	ASPHALT CONC SURFACE COURSE, TYPE S9.5B	6029000000-E	SP	250	LF	SAFETY FENCE
1560000000-E	620	137	TON	ASPHALT BINDER FOR PLANT MIX, GRADE PG 64-22	6030000000-E	1630	1,340	CY	SILT EXCAVATION
2000000000-N	806	16	EA	RIGHT OF WAY MARKERS	6036000000-E	1631	530	SY	MATTING FOR EROSION CONTROL
2253000000-E	840	1	CY	PIPE COLLARS	6037000000-E	SP	20	SY	COIR FIBER MAT
2264000000-E	840	0.5	CY	PIPE PLUGS	6038000000-E	SP	770	SY	PERMANENT SOIL REINFORCEMENT MAT
2286000000-N	840	1	EA	MASONRY DRAINAGE STRUCTURES	6071030000-E	SP	270	LF	COIR FIBER BAFFLES
2367000000-N	840	1	EA	FRAME WITH TWO GRATES, STD 840.29	6071050000-E	SP	3	EA	*** SKIMMER (1-1/2")
2556000000-E	846	25	LF	SHOULDER BERM GUTTER	6084000000-E	1660	2	ACR	SEEDING & MULCHING
2612000000-E	848	70	SY	6" CONCRETE DRIVEWAY	6087000000-E	1660	1	ACR	MOWING
2995000000-N	SP	1	EA	GENERIC DRAINAGE ITEM ADJUST EXT JUNCTION BOX WITH MANHOLE	6090000000-E	1661	50	LB	SEED FOR REPAIR SEEDING
3030000000-E	862	150	LF	STEEL BM GUARDRAIL	6093000000-E	1661	0.25	TON	FERTILIZER FOR REPAIR SEEDING
3045000000-E	862	62.5	LF	STEEL BM GUARDRAIL, SHOP CURVED	6096000000-E	1662	50	LB	SEED FOR SUPPLEMENTAL SEEDING
3150000000-N	862	5	EA	ADDITIONAL GUARDRAIL POSTS	6108000000-E	1665	1.5	TON	FERTILIZER TOPDRESSING
3195000000-N	862	1	EA	GUARDRAIL ANCHOR UNITS, TYPE AT-1	6114000000-N	SP	2	HR	SPECIALIZED HAND MOWING
3215000000-N	862	4	EA	GUARDRAIL ANCHOR UNITS, TYPE III	6117000000-N	SP	8	EA	RESPONSE FOR EROSION CONTROL
3270000000-N	SP	3	EA	GUARDRAIL ANCHOR UNITS, TYPE 350					
3649000000-E	876	10	TON	RIP RAP, CLASS B					
3656000000-E	876	296	SY	FILTER FABRIC FOR DRAINAGE					
4400000000-E	1110	431	SF	WORK ZONE SIGNS (STATIONARY)					
4405000000-E	1110	144	SF	WORK ZONE SIGNS (PORTABLE)					
4410000000-E	1110	70	SF	WORK ZONE SIGNS (BARRICADE MOUNTED)					
4435000000-N	1135	30	EA	CONES					
4445000000-E	1145	80	LF	BARRICADES (TYPE III)					
4455000000-N	1150	90	MD	FLAGGER					
4810000000-E	1205	9,080	LF	PAINT PAVEMENT MARKING LINES (4")					
4835000000-E	1205	69	LF	PAINT PAVEMENT MARKING LINES (24")					
5325600000-E	1510	1,050	LF	6" WATER LINE					

6/4/99  
5/7/2007  
C:\Roadway\Proj\N4243-Rdy.sum=ear-thwork.dgn

DIVISION OF HIGHWAYS  
 STATE OF NORTH CAROLINA

**SUMMARY OF EARTHWORK**

IN CUBIC YARDS

LOCATION	UNCLASSIFIED EXCAVATION	UNDERCUT	EMBT + %	BORROW	WASTE
<b>SUMMARY NO. 1</b>					
-L- 16+00 TO 19+14	273		1611	1338	
<b>TOTAL SUMMARY NO. 1</b>	<b>273</b>		<b>1611</b>	<b>1338</b>	
<b>SUMMARY NO. 2</b>					
-L- 20+04 TO 24+50	200		2176	1976	
<b>TOTAL SUMMARY NO. 2</b>	<b>200</b>		<b>2176</b>	<b>1976</b>	
<b>SUMMARY NO. 3</b>					
-Y- 10+55 TO 13+50	42		443	401	
<b>TOTAL SUMMARY NO. 3</b>	<b>42</b>		<b>443</b>	<b>401</b>	
<b>SUB-TOTAL SUMMARY NOS. 1 THRU 3</b>	<b>515</b>		<b>4230</b>	<b>3715</b>	
<b>EST. 5% FOR REPLACING TOPSOIL IN BORROW PITS</b>				<b>186</b>	
<b>GRAND TOTALS</b>	<b>515</b>		<b>4230</b>	<b>3901</b>	
<b>SAY</b>	<b>550</b>			<b>3950</b>	

ESTIMATE DDE = 260 CY  
 ESTIMATE UNDERCUT EXCAVATION = 550 CY  
 SELECT MATERIAL, CLASS II OR III = 200 CY  
 CL IV SUBGRADE STABILIZATION = 200 TONS

NOTE: Approximate quantities only. Unclassified Excavation, Fine Grading, Clearing and Grubbing, Breaking of Existing Pavement and Removal of Existing Pavement will be paid for at the contract lump sum price for "Grading."

NOTE: Earthwork quantities are calculated by the Roadway Design Unit. These earthwork quantities are based in part on subsurface data provided by the Geotechnical Engineering Unit.

6/4/99  
 7/5/2007  
 R:\Roadway\Projects\B4243-Rdy\_sum\_earthwork.dgn  
 Co. & Associates, P.A.





8/17/99

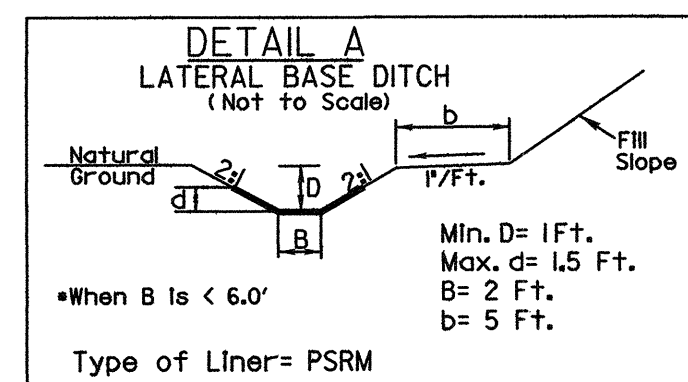

FROM -L- STA. 18+00 TO STA. 19+43 LT 121.0 CY DDE  
 FROM -L- STA. 19+60 TO STA. 20+92 LT 71.5 CY DDE  
 FROM -L- STA. 17+60 TO STA. 19+55 RT 65.0 CY DDE

B4243-1  
 -BL- POT 5+00.00 =  
 -L- STA. 13+14.74 20.61' LT

ENERGIZER BATTERY MANUFACTURING, INC.  
 DB 1883 PG 2238

BEGIN PROJECT B-4243  
 -L- POT STA. 16+00.00

BEGIN CONSTRUCTION  
 -L- POT STA. 14+80.00

NC GRID NAD 8395

-Y- POT STA. 10+55.00  
 BEGIN CONSTRUCTION

-L-  
 PI Sta 26+32.00  
 $\Delta = 25' 45" 07.8" (LT)$   
 $D = 8' 11" 06.4"$   
 $L = 314.62'$   
 $T = 160.01'$   
 $R = 700.00'$

END PROJECT B-4243  
 -L- POT STA. 24+50.00

END CONSTRUCTION  
 -L- POC STA. 25+00.00

-L-  
 PI Sta 13+30.66  
 $\Delta = 23' 12" 11.8" (RT)$   
 $D = 6' 01" 52.1"$   
 $L = 384.73'$   
 $T = 195.04'$   
 $R = 950.00'$

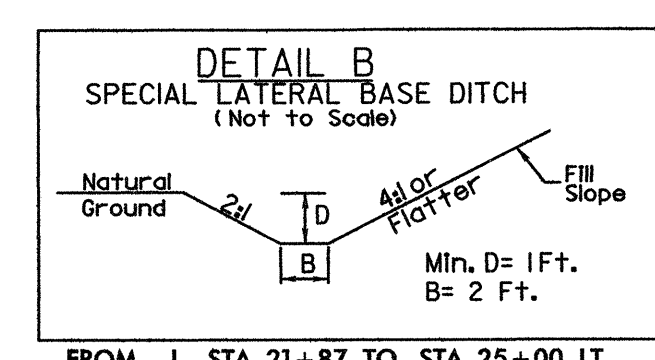

FROM -L- STA. 21+87 TO STA. 25+00 LT

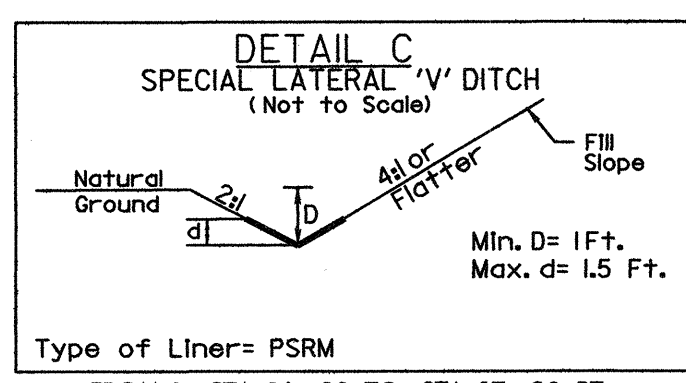

FROM -L- STA. 16+00 TO STA. 17+20 RT

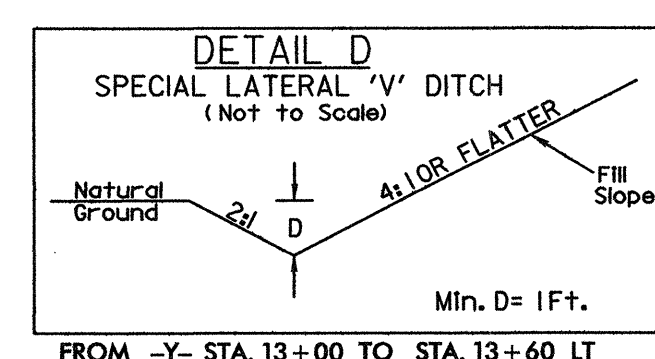

FROM -Y- STA. 13+00 TO STA. 13+60 LT

7/2/2007  
 P:\Roadway\Proj\B4243.Rdw-psw.dgn  
 KO & Associates, P.C.

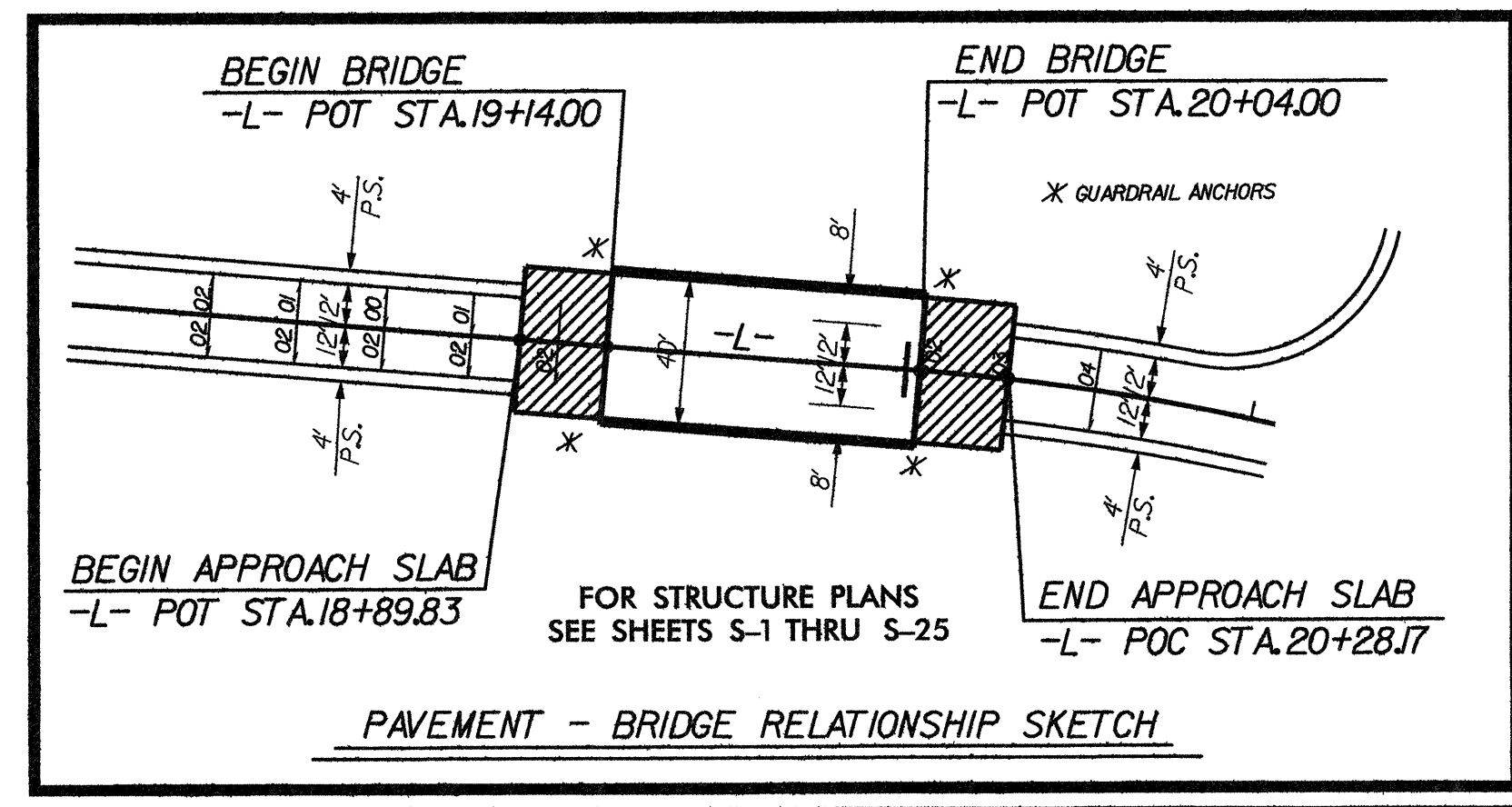
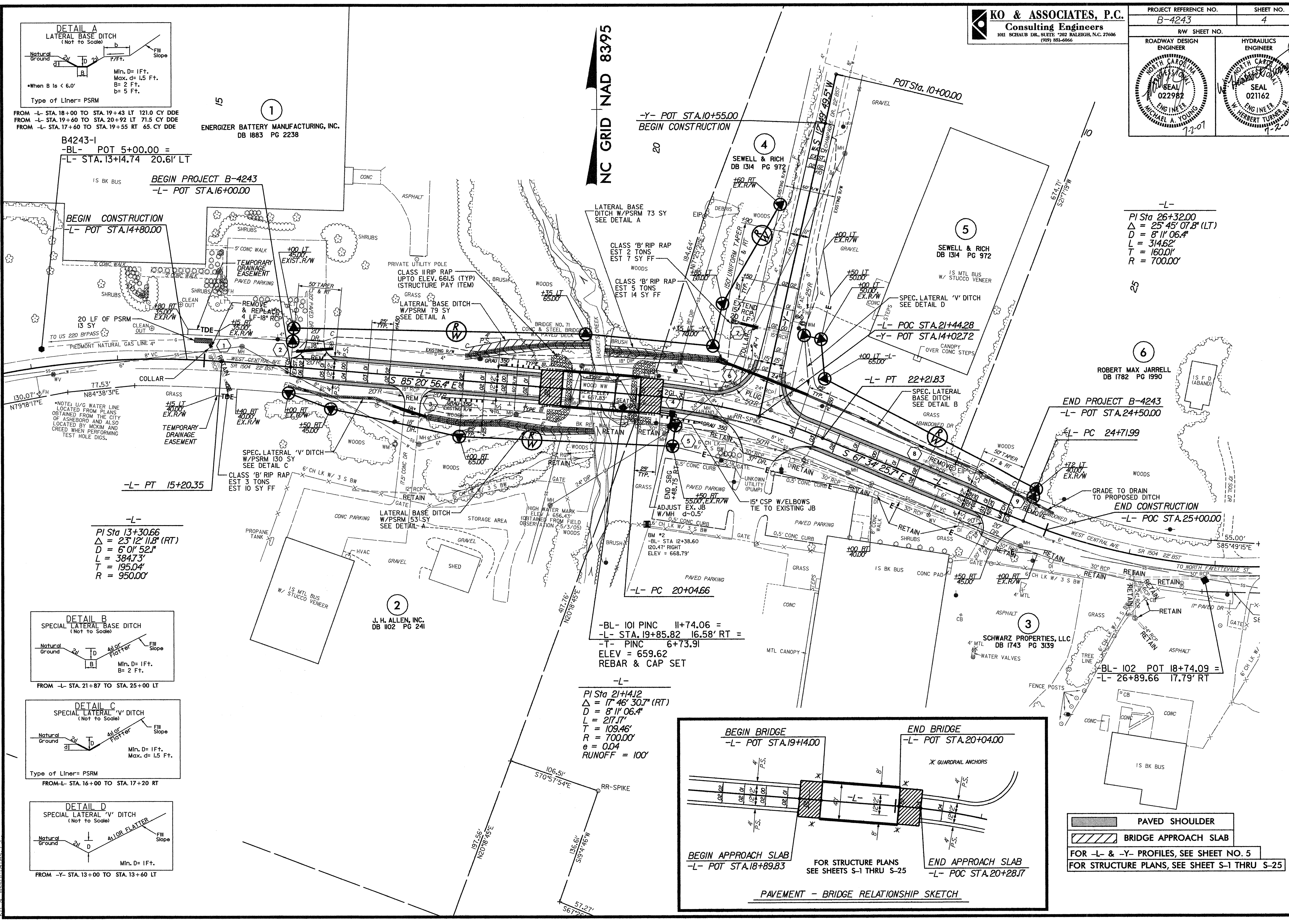

PAVED SHOULDER  
 BRIDGE APPROACH SLAB  
 FOR -L- & -Y- PROFILES, SEE SHEET NO. 5  
 FOR STRUCTURE PLANS, SEE SHEET S-1 THRU S-25

5/28/99

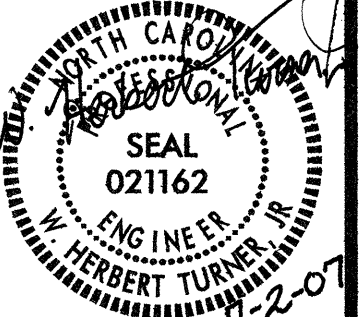
PROJECT REFERENCE NO. B-4243	SHEET NO. 5
ROADWAY DESIGN ENGINEER	HYDRAULICS ENGINEER
	

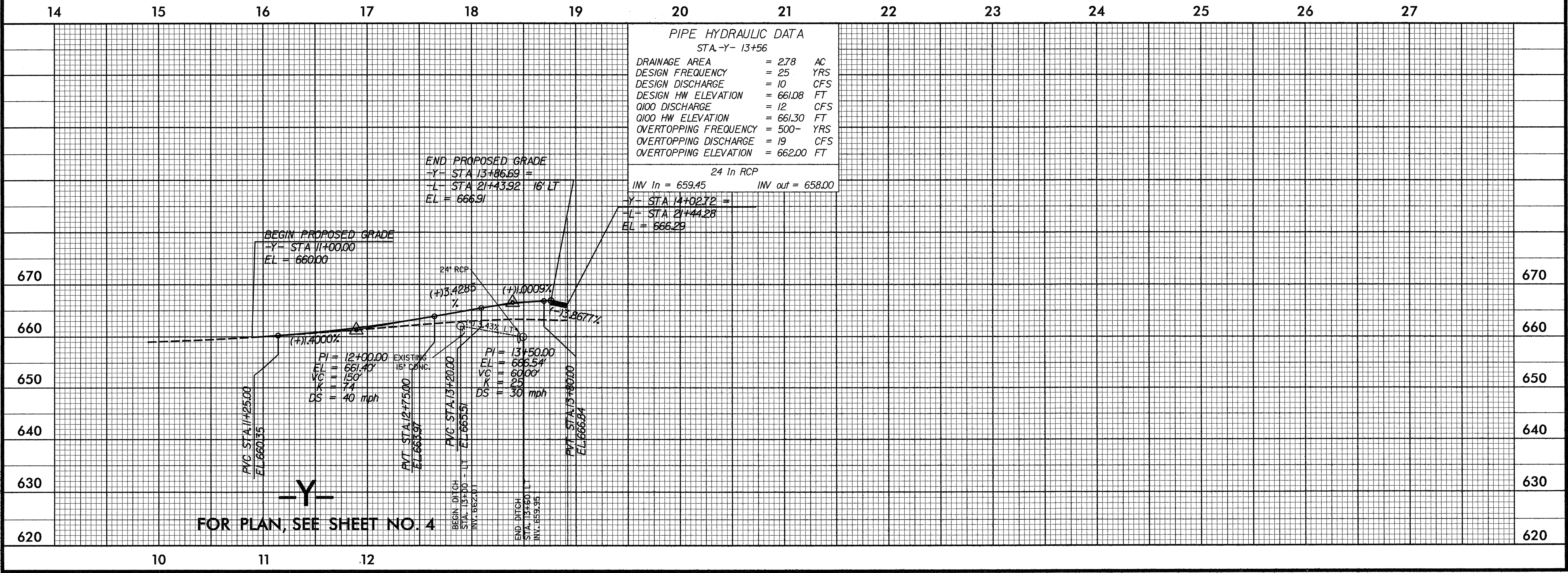
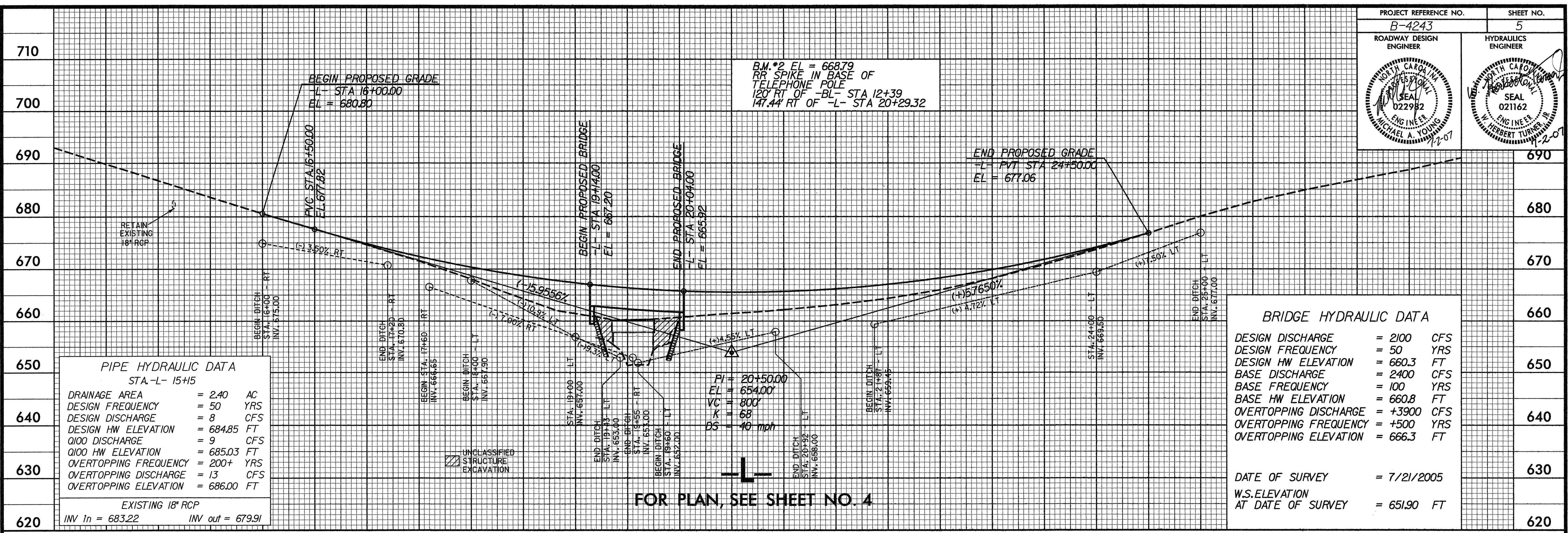

7/2/2007  
F:\Roadway\Proj\B4243-Rdy-pf1\_05.dgn