

TIP PROJECT: B-0682

STATE OF NORTH CAROLINA
 DIVISION OF HIGHWAYS
 PLAN FOR PROPOSED
 HIGHWAY EROSION CONTROL
BRUNSWICK COUNTY

**LOCATION: BRIDGE No. 198 OVER THE INTERCOASTAL WATERWAY
 AND APPROACHES ON SR 1172 AT SUNSET BEACH**
TYPE OF WORK: GRADING, DRAINAGE, PAVING, AND STRUCTURE

STATE	STATE PROJECT REFERENCE NO.	SHEET NO.	TOTAL SHEETS
N.C.	B-0682	EC-1	
STATE PROJ. NO.	F.A. PROJ. NO.	DESCRIPTION	

EROSION AND SEDIMENT CONTROL MEASURES

Std. #	Description	Symbol
	Streambank Reforestation	
1630.03	Temporary Silt Ditch	
1630.05	Temporary Diversion	
1605.01	Temporary Silt Fence	
1606.01	Special Sediment Control Fence	
1622.01	Temporary Berms and Slope Drains	
1630.01	Riser Basin	
1630.02	Silt Basin Type B	
1633.01	Temporary Rock Silt Check Type-A	
	Temporary Rock Silt Check Type-B	
1634.01	Temporary Rock Sediment Dam Type-A	
1634.02	Temporary Rock Sediment Dam Type-B	
1635.01	Rock Pipe Inlet Sediment Trap Type-A	
1635.02	Rock Pipe Inlet Sediment Trap Type-B	
1630.04	Stilling Basin	
	Rock Inlet Sediment Trap:	
1632.01	Type A	
1632.02	Type B	
1632.03	Type C	
	Skimmer Basin	
	Tiered Skimmer Basin	

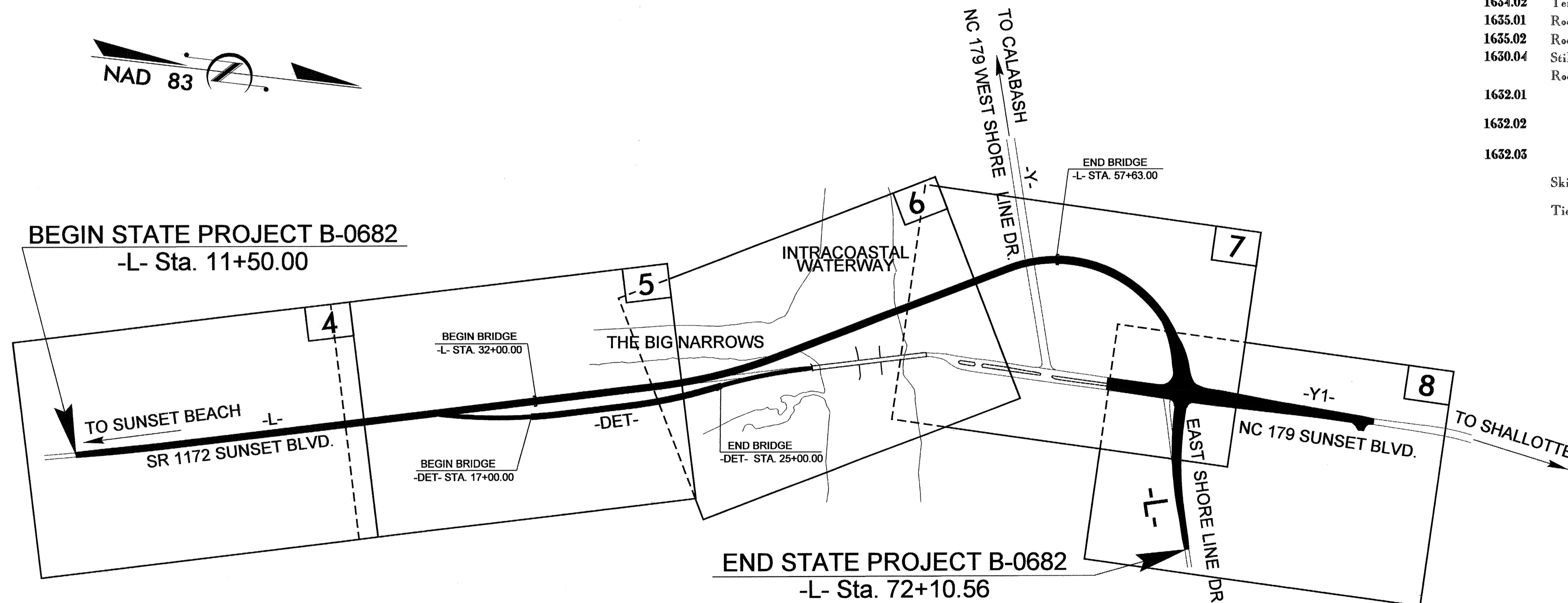

**THIS PROJECT CONTAINS
 EROSION CONTROL PLANS
 FOR CLEARING AND
 GRUBBING PHASE OF
 CONSTRUCTION.**

**THIS PROJECT HAS
 BEEN DESIGNED TO
 SENSITIVE WATERSHED
 STANDARDS.**

**HIGH QUALITY WATER(S) EXIST
 ON THIS PROJECT**
*High Quality Water Zone(s) Exist
 From Sta. 11+50
 to Sta. 72+10.56
 Refer To E. C. Special Provisions
 for Special Considerations.*

GRAPHIC SCALE

0

PLANS

0

PROFILE (HORIZONTAL)

0

PROFILE (VERTICAL)

ROADSIDE ENVIRONMENTAL UNIT
 DIVISION OF HIGHWAYS
 STATE OF NORTH CAROLINA

Prepared In the Office of:
ROADSIDE ENVIRONMENTAL UNIT
 1 South Wilmington St.
 Raleigh, NC 27611
2006 STANDARD SPECIFICATIONS

Roadway Standard Drawings

The following roadway english standards as appear in "Roadway Standard Drawings"- Roadway Design Unit - N. C. Department of Transportation - Raleigh, N. C., dated July 18, 2006 and the latest revision thereto are applicable to this project and by reference hereby are considered a part of these plans.

1605.01 Temporary Silt Fence	1630.06 Special Stilling Basin
1606.01 Special Sediment Control Fence	1632.03 Rock Inlet Sediment Trap Type C
1607.01 Gravel Construction Entrance	1633.01 Temporary Rock Silt Check Type A
1622.01 Temporary Berms and Slope Drains	1634.02 Temporary Rock Sediment Dam Type B
1630.02 Silt Basin Type B	
1630.05 Temporary Diversion	

PROJECT REFERENCE NO. B-0682	SHEET NO. EC-2
RW SHEET NO.	
ROADWAY DESIGN ENGINEER	HYDRAULICS ENGINEER

TEMPORARY ROCK SILT CHECK TYPE 'B' DETAIL

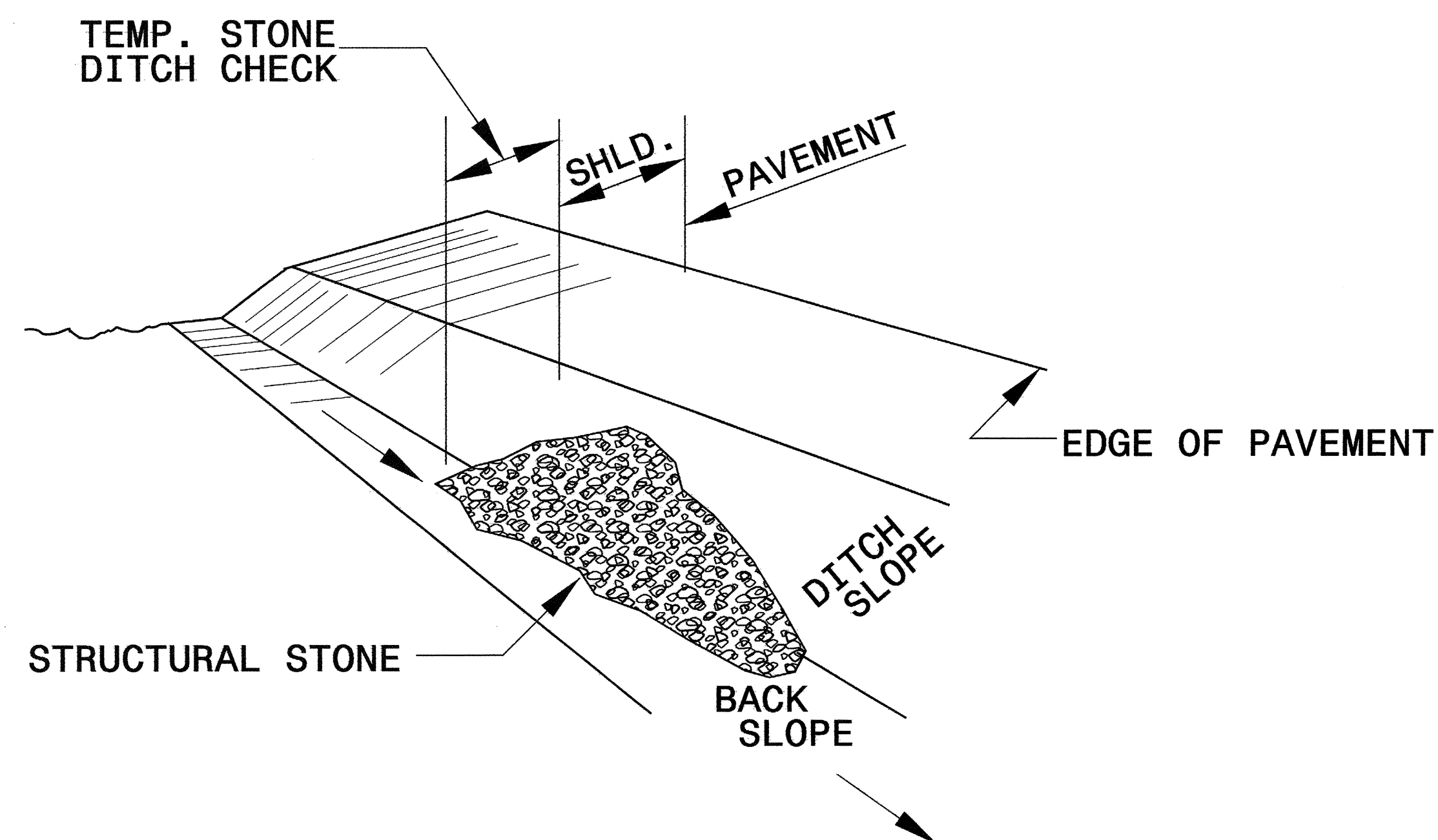

ISOMETRIC VIEW

NOTES:

USE CLASS 'B' EROSION CONTROL STONE FOR STRUCTURAL STONE.

THE ENGINEER MAY DIRECT THE OPTION OF CLASS "A" STONE FOR SITES HAVING LESS THAN ONE (1) ACRE DRAINAGE AREA AND A DITCH GRADE LESS THAN 3%.

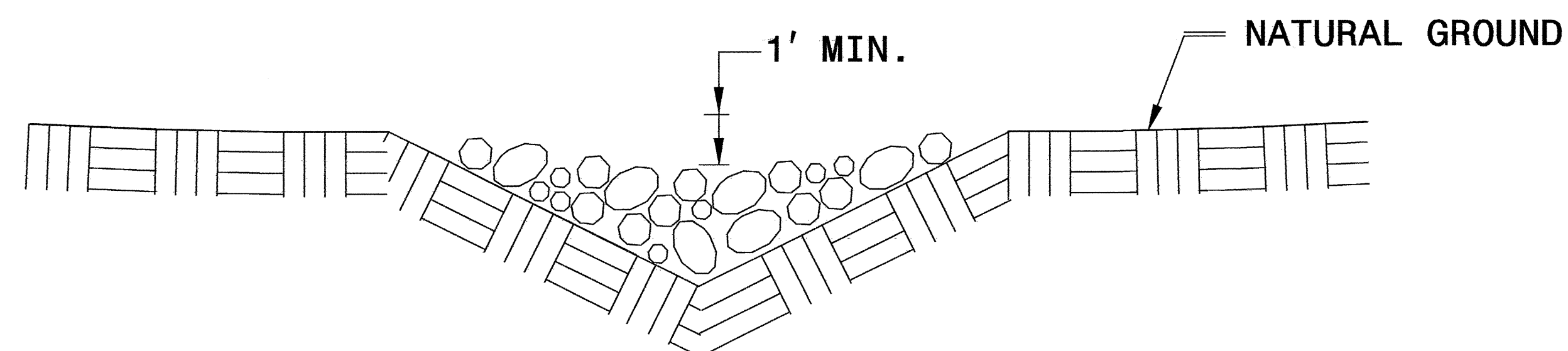

**CROSS SECTION
VEE DITCH**

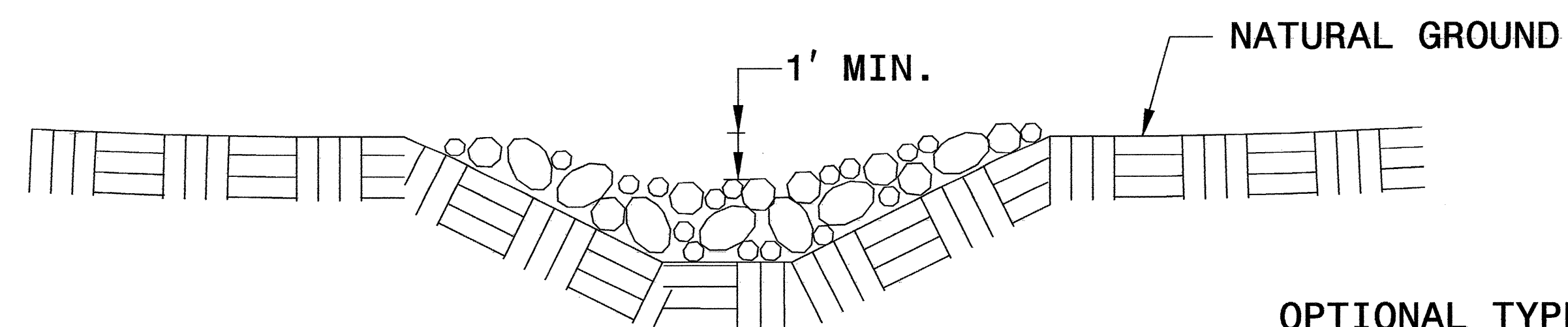

**CROSS SECTION
TRAPEZOIDAL DITCH**

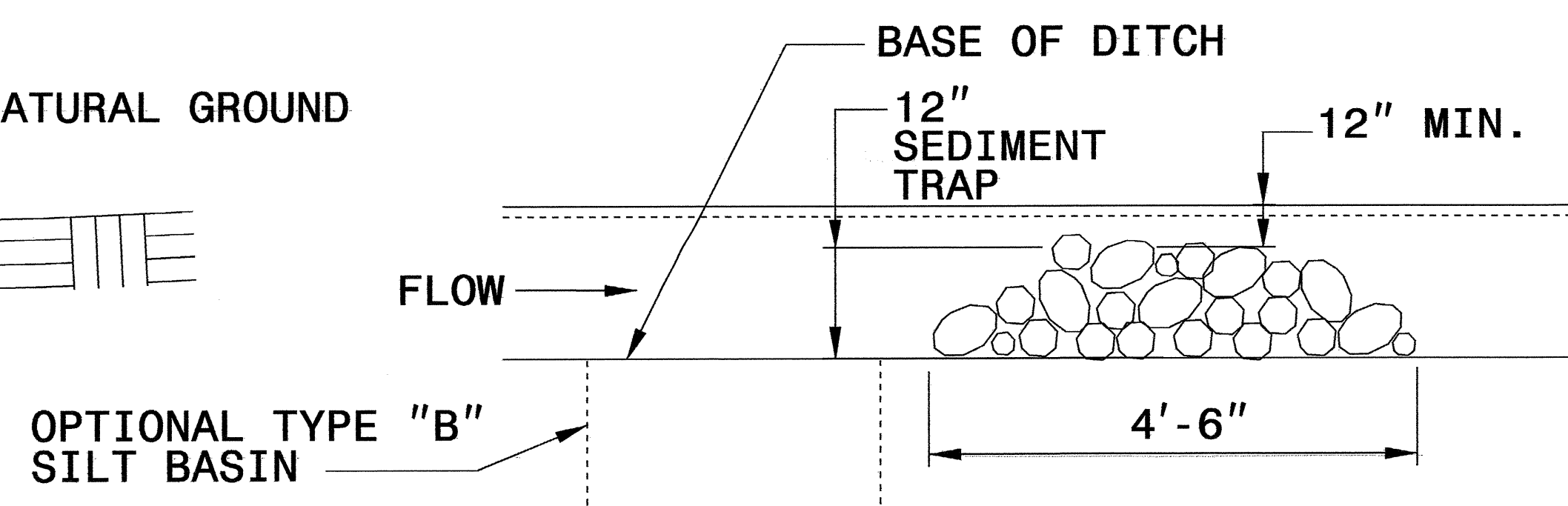

ELEVATION VIEW

PROJECT REFERENCE NO. <i>B-0682</i>	SHEET NO. <i>EC-2A</i>
RW SHEET NO.	
ROADWAY DESIGN ENGINEER	HYDRAULICS ENGINEER

COIR FIBER BAFFLE DETAIL

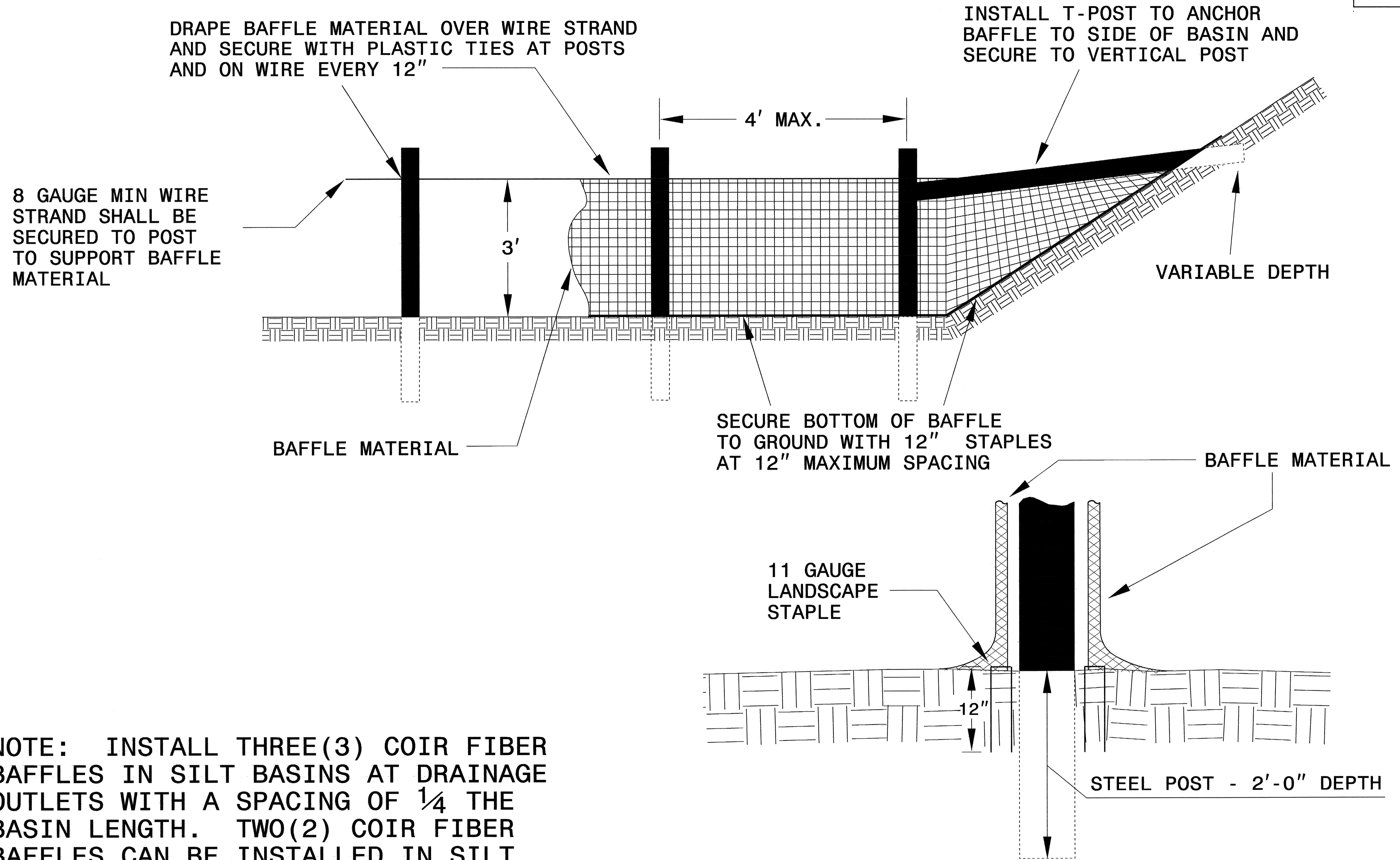

NOTE: INSTALL THREE (3) COIR FIBER BAFFLES IN SILT BASINS AT DRAINAGE OUTLETS WITH A SPACING OF $\frac{1}{4}$ THE BASIN LENGTH. TWO (2) COIR FIBER BAFFLES CAN BE INSTALLED IN SILT BASINS LESS THAN 20 FT. IN LENGTH WITH A SPACING OF $\frac{1}{3}$ THE BASIN LENGTH.

BAFFLE MATERIAL SHALL BE SECURED TO THE BOTTOM AND SIDES OF BASIN USING 12" LANDSCAPE STAPLES

SKIMMER BASIN WITH BAFFLES DETAIL

PROJECT REFERENCE NO. B-0682	SHEET NO. EC-2B
RW SHEET NO.	
ROADWAY DESIGN ENGINEER	HYDRAULICS ENGINEER

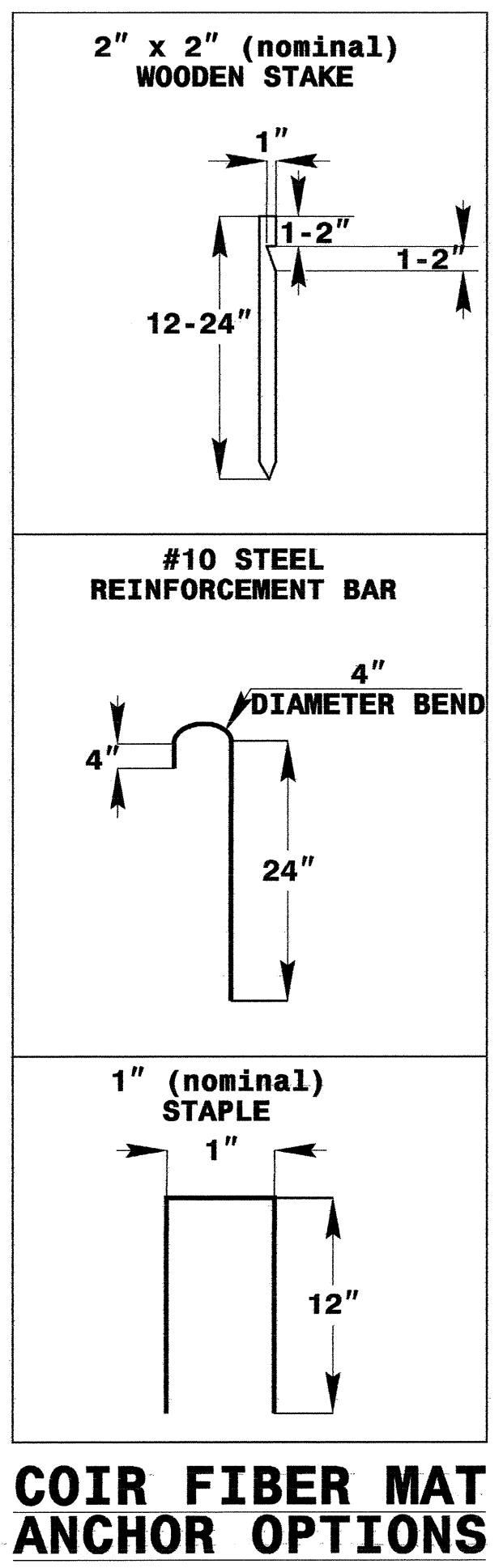
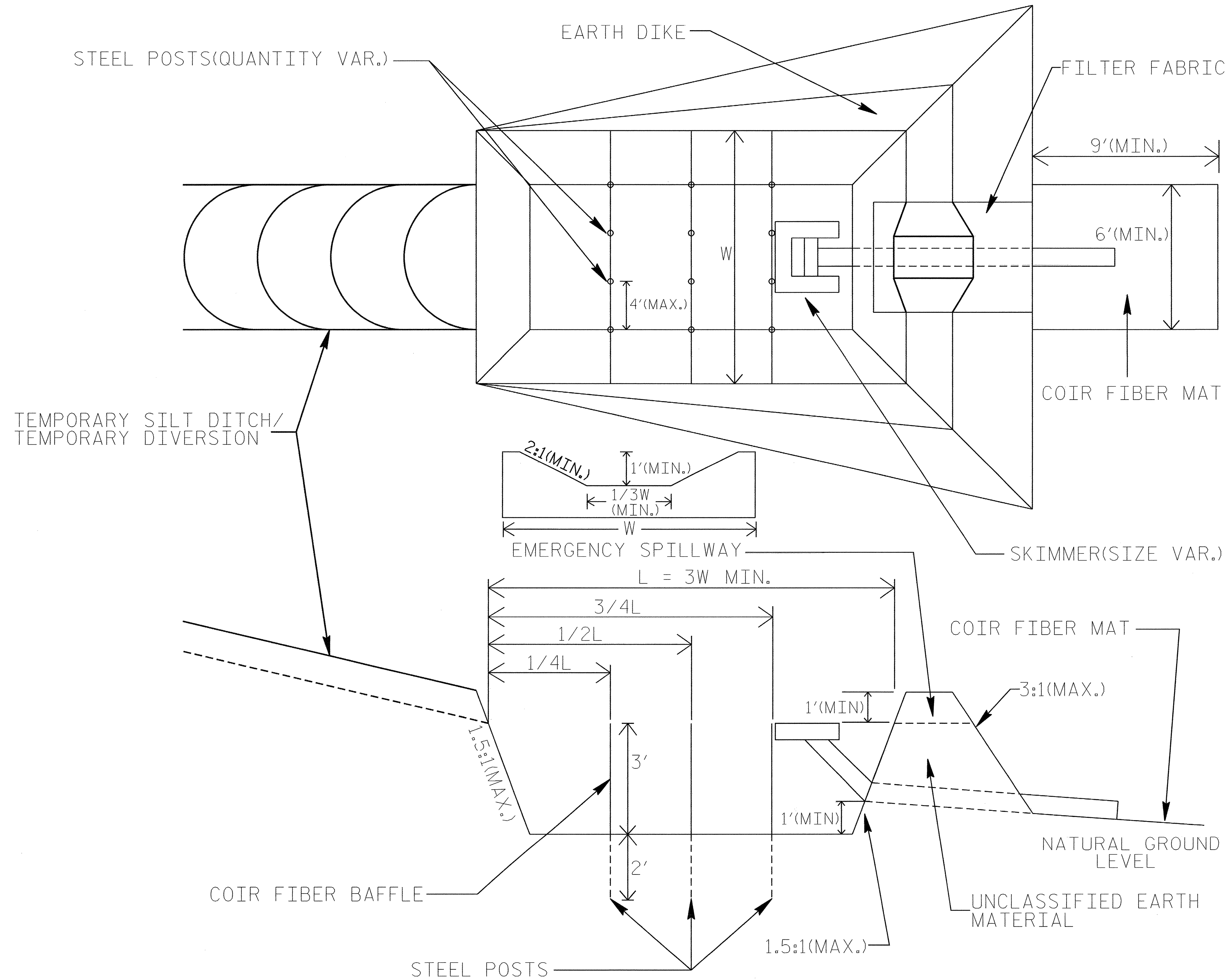

DIVISION OF HIGHWAYS
STATE OF NORTH CAROLINA

PROJECT REFERENCE NO. <i>B-0682</i>	SHEET NO. <i>EC-3</i>
ROADWAY DESIGN ENGINEER	HYDRAULICS ENGINEER

SOIL STABILIZATION SUMMARY SHEET

MATTING FOR EROSION CONTROL

PERMANENT SOIL REINFORCEMENT MAT

CONST SHEET NO.	LINE	FROM STATION	TO STATION	SIDE	ESTIMATE (SY)
7	-YI-	18+50	19+00	LEFT	240
7	-YI-	20+50	22+00	LEFT	415
7	-YI-	20+50	22+00	RIGHT	275
7	-L-	59+50	64+50	RIGHT	915
7	-L-	66+00	67+00	LEFT	225
8	-YI-	22+00	28+00	RIGHT	1610
8	-YI-	22+00	28+00	LEFT	930
			SUBTOTAL		4610
	MISCELLANEOUS MATTING TO BE INSTALLED AS DIRECTED BY THE ENGINEER				1150
			TOTAL		5760
			SAY		5800

CONST SHEET NO.	LINE	FROM STATION	TO STATION	SIDE	ESTIMATE (SY)
7	-L-	64+00	64+50	LEFT	255
			SUBTOTAL		255
			ADDITIONAL PERM TO BE INSTALLED		0
			TOTAL		255
			SAY		275

PROJECT REFERENCE NO. B-0682	SHEET NO. EC-4/CONST.4
RW SHEET NO.	
ROADWAY DESIGN ENGINEER	HYDRAULICS ENGINEER

NOTE:
PLACE TEMPORARY ROCK SILT CHECKS TYPE - A AT DRAINAGE OUTLETS.

CLEARING AND GRUBBING EROSION CONTROL FOR CONSTRUCTION SHEET 4

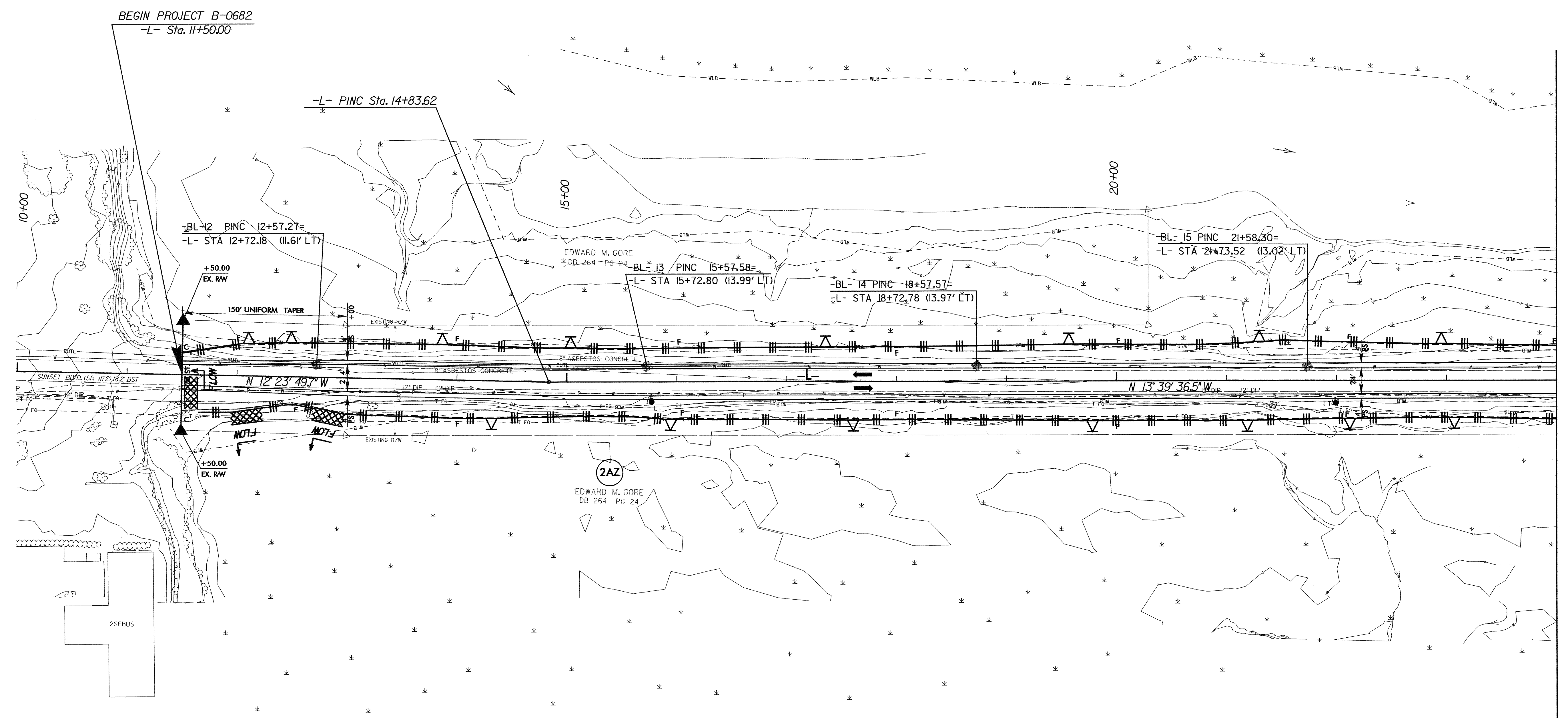
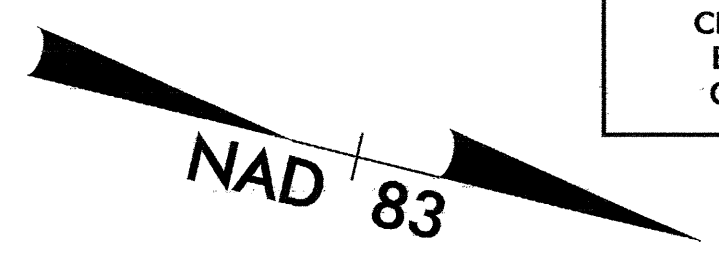

BEGIN PROJECT B-0682
-L- Sta. 11+50.00

-L- PINC Sta. 14+83.62

-BL-12 PINC 12+57.27=
-L- STA 12+72.18 (11.61' LT)

-BL-13 PINC 15+57.58=
-L- STA 15+72.80 (13.99' LT)

-BL-14 PINC 18+57.57=
-L- STA 18+72.78 (13.97' LT)

-BL-15 PINC 21+58.30=
-L- STA 21+73.52 (13.02' LT)

SUNSET BLVD. (SR 1122) 16.2' BST

N 12° 23' 49.7\"/>

N 13° 39' 36.5\"/>

2AZ
EDWARD M. GORE
DB 264 PG 24

25FBUS

MATCHLINE -L- STA 24+00 SEE SHEET 5

SEE SHEET 9 FOR -L- PROFILE

PROJECT REFERENCE NO. B-0682	SHEET NO. EC-5/CONST.5
RW SHEET NO.	
ROADWAY DESIGN ENGINEER	HYDRAULICS ENGINEER

NOTE:
PLACE TEMPORARY ROCK SILT CHECKS TYPE - A AT DRAINAGE OUTLETS.

CLEARING AND GRUBBING EROSION CONTROL FOR CONSTRUCTION SHEET 5

NOTE:
UTILIZE SPECIAL STILLING BASIN AS STILLING BASIN WHERE APPLICABLE.

-L-
PI Sta 40+10.40
 $\Delta = 14^{\circ} 00' 31.7''$ (LT)
D = 2' 30" 00.0"
L = 560.35'
T = 281.58'
R = 2,291.83'
SE = 03

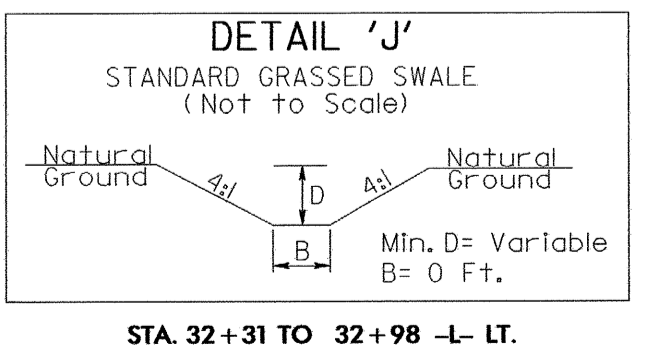
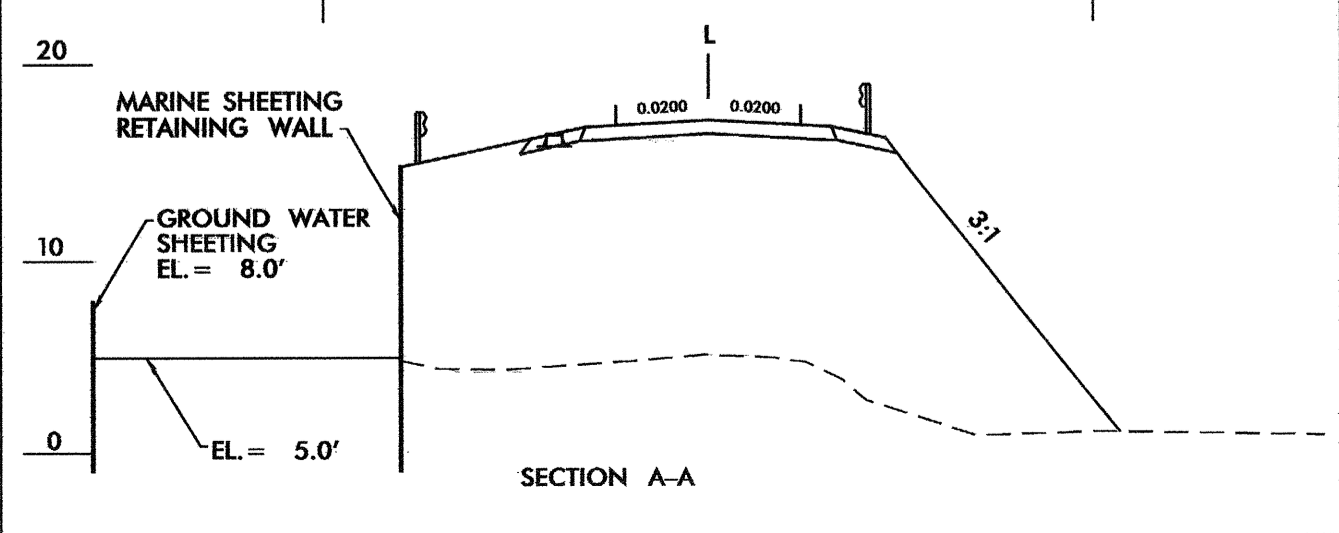
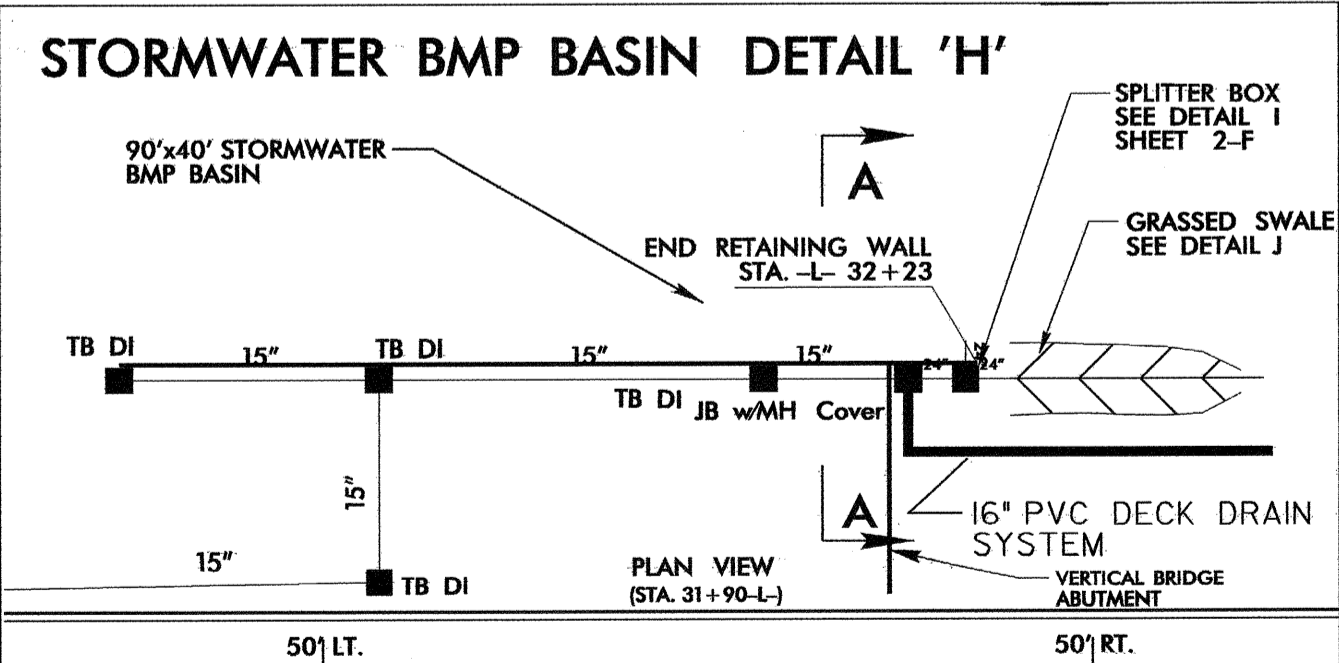
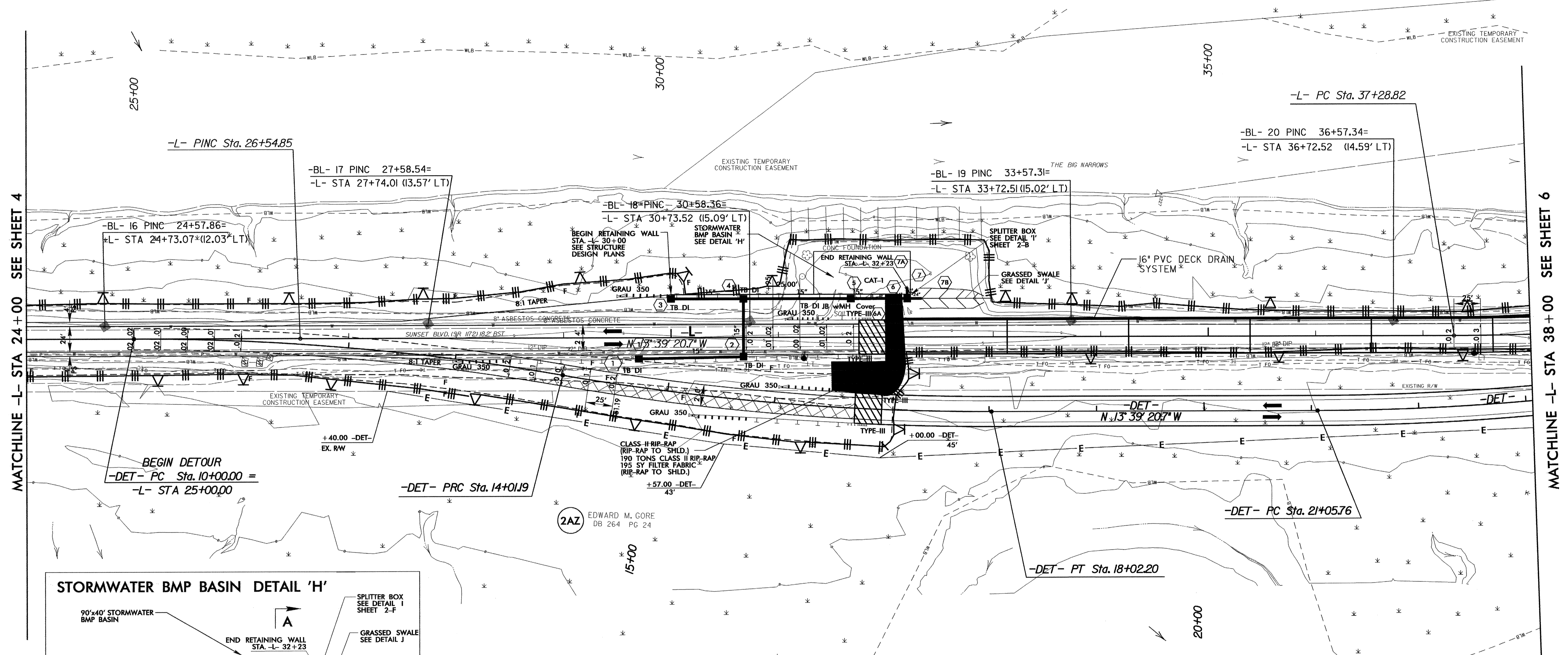
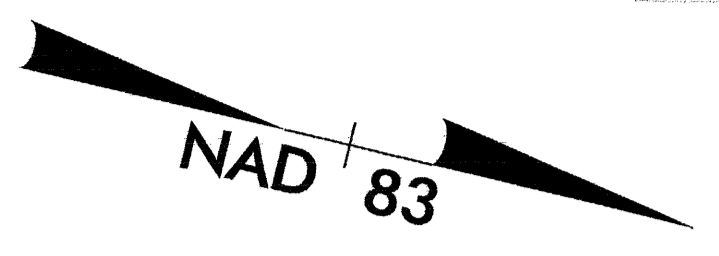

-DET-
PI Sta 12+01.11
 $\Delta = 10^{\circ} 01' 46.9''$ (RT)
D = 2' 30" 00.0"
L = 401.19'
T = 201.02'
R = 2,291.83'
SE = 0.02

PI Sta 16+02.21
 $\Delta = 10^{\circ} 01' 31.1''$ (LT)
D = 2' 30" 00.0"
L = 401.01'
T = 201.02'
R = 2,291.83'
SE = 0.02

PI Sta 23+05.19
 $\Delta = 9^{\circ} 56' 46.1''$ (LT)
D = 2' 30" 00.0"
L = 397.85'
T = 199.42'
R = 2,291.83'
SE = 0.02

MATCHLINE -L- STA 24+00 SEE SHEET 4

MATCHLINE -L- STA 38+00 SEE SHEET 6

PROJECT REFERENCE NO. B-0682	SHEET NO. EC-6/CONST.6
RW SHEET NO.	
ROADWAY DESIGN ENGINEER	HYDRAULICS ENGINEER

NOTE:

PLACE TEMPORARY ROCK SEDIMENT DAMS TYPE - B AND TEMPORARY ROCK SILT CHECKS TYPE - A AT DRAINAGE OUTLETS.

CLEARING AND GRUBBING EROSION CONTROL FOR CONSTRUCTION SHEET 6

NOTE: UTILIZE SPECIAL STILLING BASIN AS STILLING BASIN WHERE APPLICABLE.

-L-	-DET-	-L-
PI Sta 40+10.40	PI Sta 23+05.19	PI Sta 27+04.83
$\Delta = 14^{\circ} 00' 31.7" (LT)$	$\Delta = 9^{\circ} 56' 46.1" (LT)$	$\Delta = 10^{\circ} 02' 06.8" (RT)$
$D = 2^{\circ} 30' 00.0"$	$D = 2^{\circ} 30' 00.0"$	$D = 2^{\circ} 30' 00.0"$
$L = 560.35'$	$L = 397.85'$	$L = 401.41'$
$T = 281.58'$	$T = 199.42'$	$T = 201.22'$
$R = 2,291.83'$	$R = 2,291.83'$	$R = 2,291.83'$
$SE = 03$	$SE = 02$	$SE = 02$

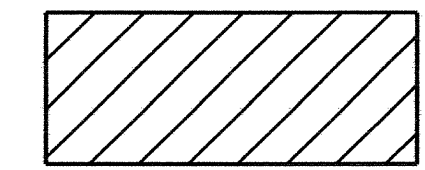

ENVIRONMENTALLY SENSITIVE AREA
SEE PROJECT SPECIAL PROVISIONS

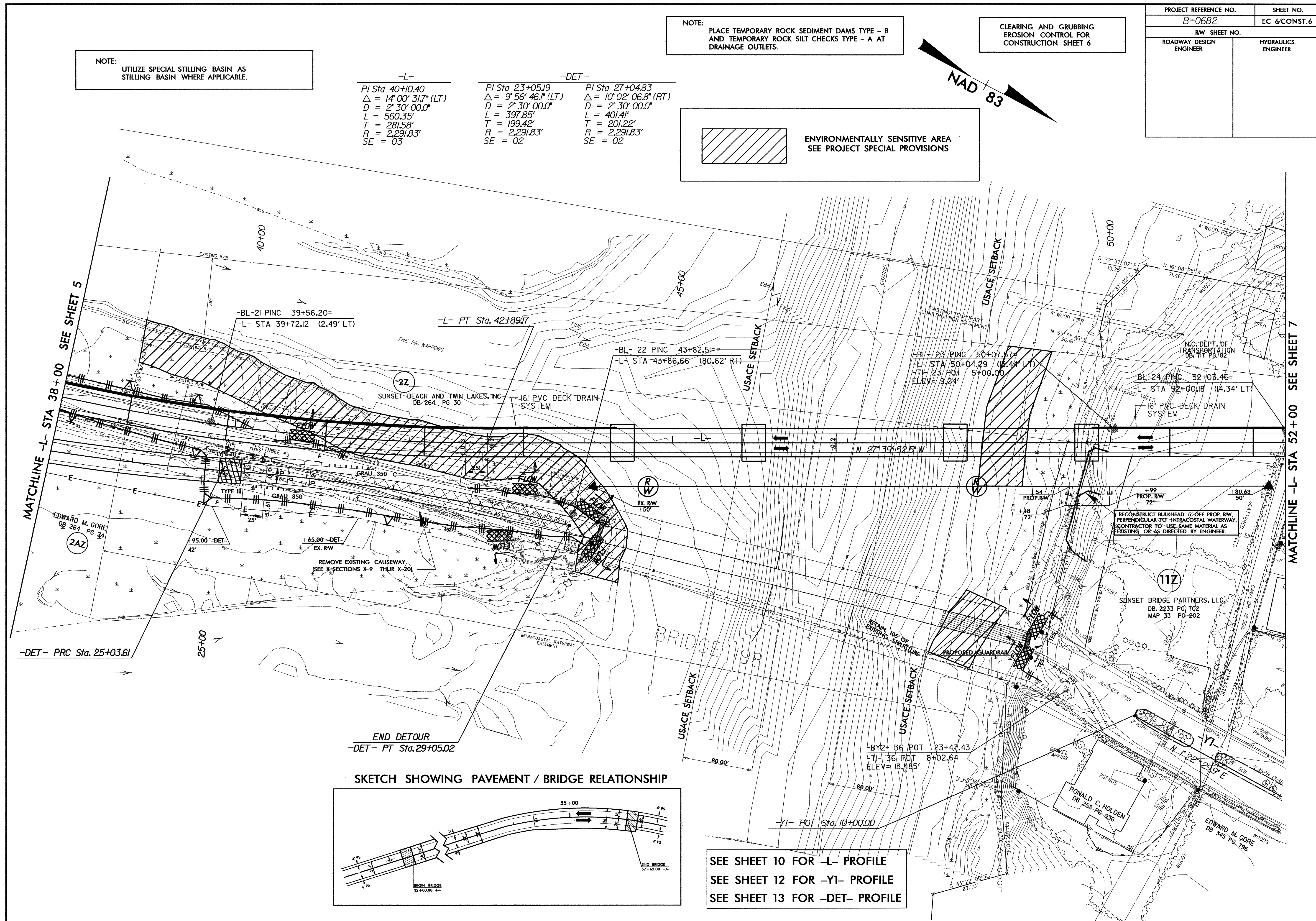
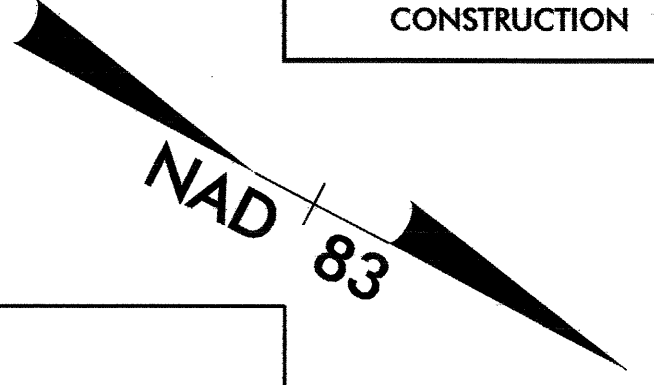

MATCHLINE -L- STA 38+00 SEE SHEET 5

MATCHLINE -L- STA 52+00 SEE SHEET 7

END DETOUR
-DET- PT Sta. 29+05.02
SKETCH SHOWING PAVEMENT / BRIDGE RELATIONSHIP

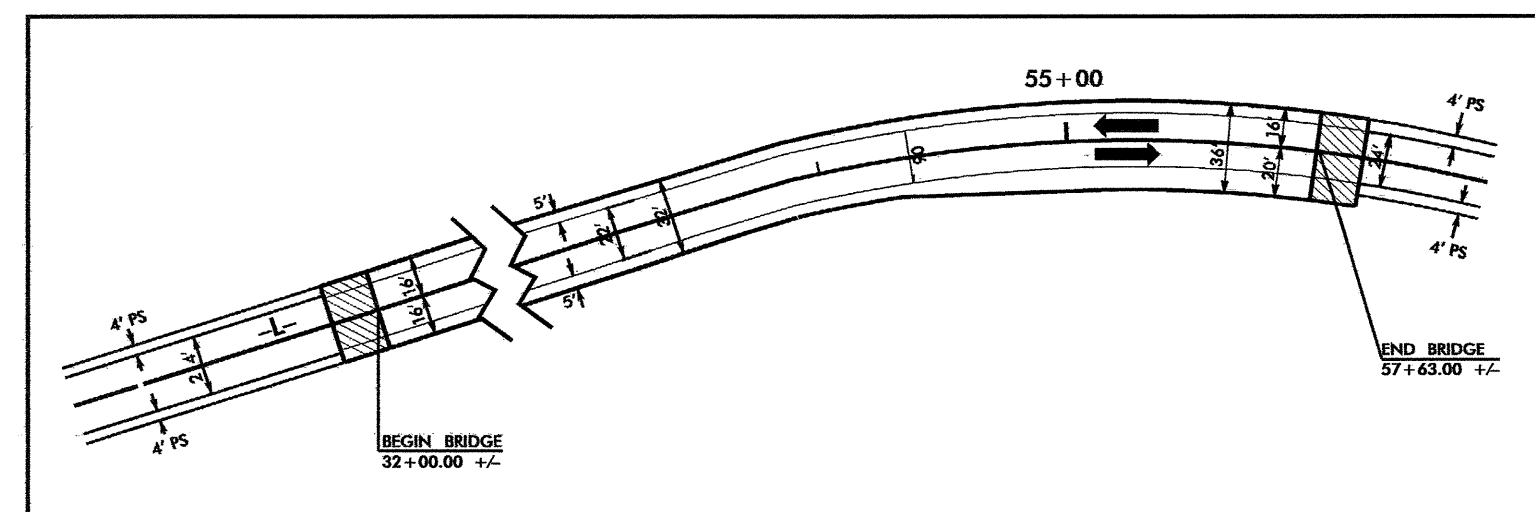

SEE SHEET 10 FOR -L- PROFILE
SEE SHEET 12 FOR -Y1- PROFILE
SEE SHEET 13 FOR -DET- PROFILE

PROJECT REFERENCE NO.	SHEET NO.
B-0682	EC-7/CONST.7
R/W SHEET NO.	HYDRAULICS ENGINEER
ROADWAY DESIGN ENGINEER	

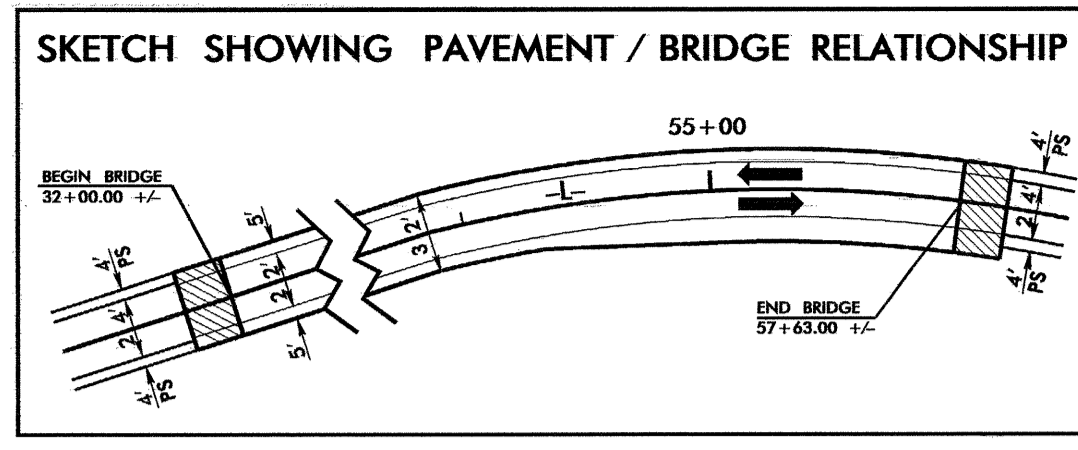
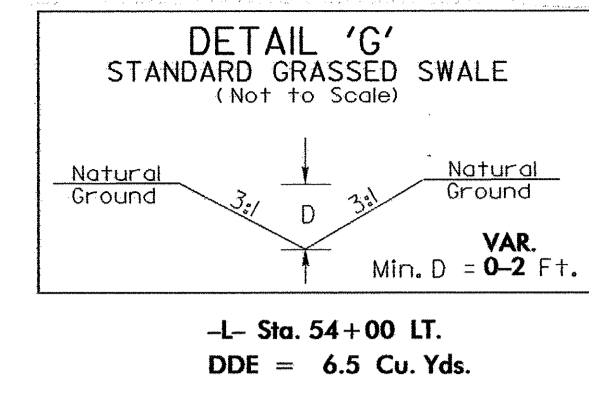
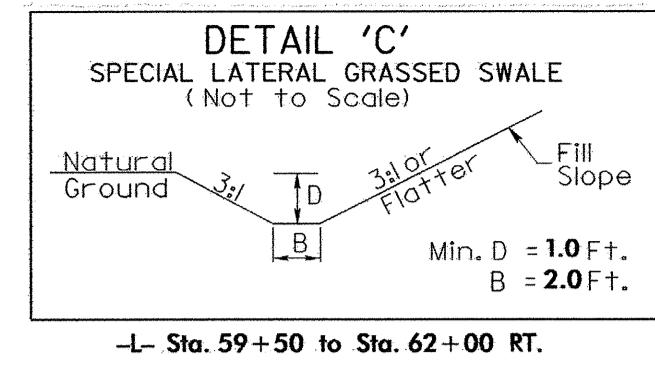
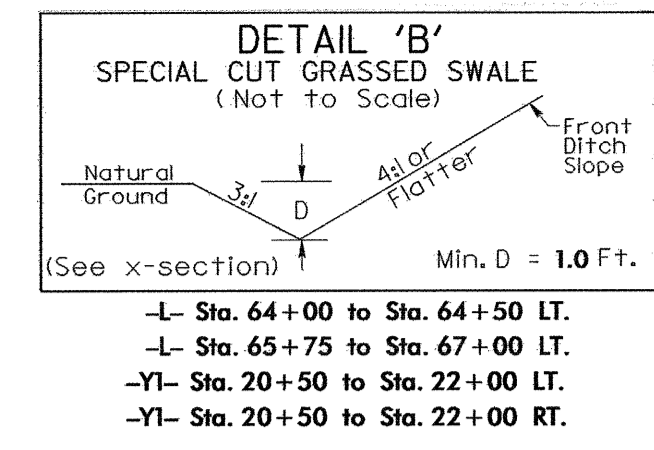
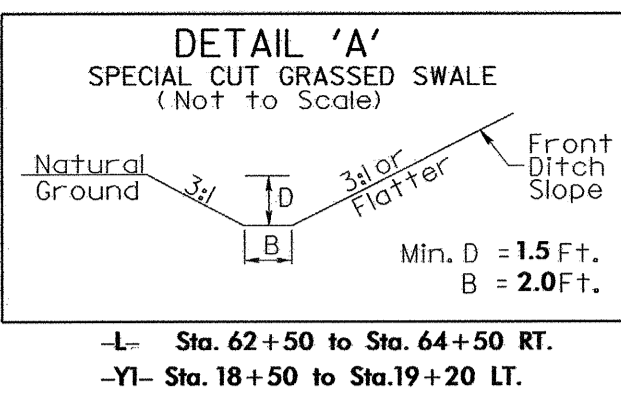

NOTE: PLACE TEMPORARY ROCK SEDIMENT DAMS TYPE - B AND TEMPORARY ROCK SILT CHECKS TYPE - A AT DRAINAGE OUTLETS.

CLEARING AND GRUBBING EROSION CONTROL FOR CONSTRUCTION SHEET 7

NOTE: UTILIZE SPECIAL STILLING BASIN AND/OR TEMPORARY ROCK SEDIMENT DAM TYPE - B AS STILLING BASIN WHERE APPLICABLE.

ENVIRONMENTALLY SENSITIVE AREA SEE PROJECT SPECIAL PROVISIONS

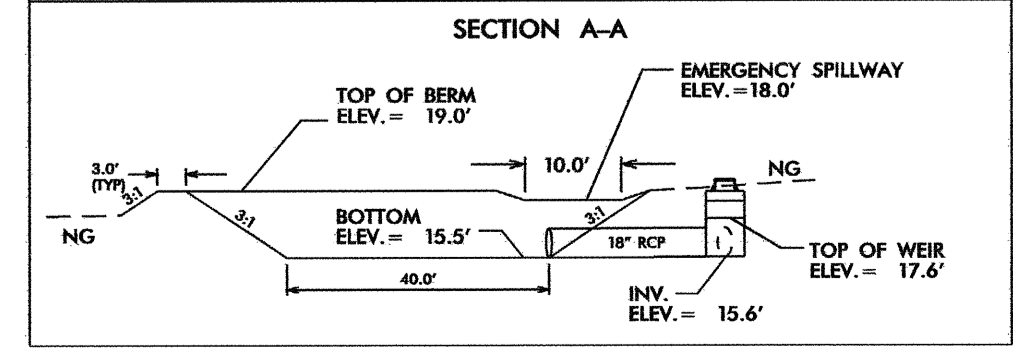
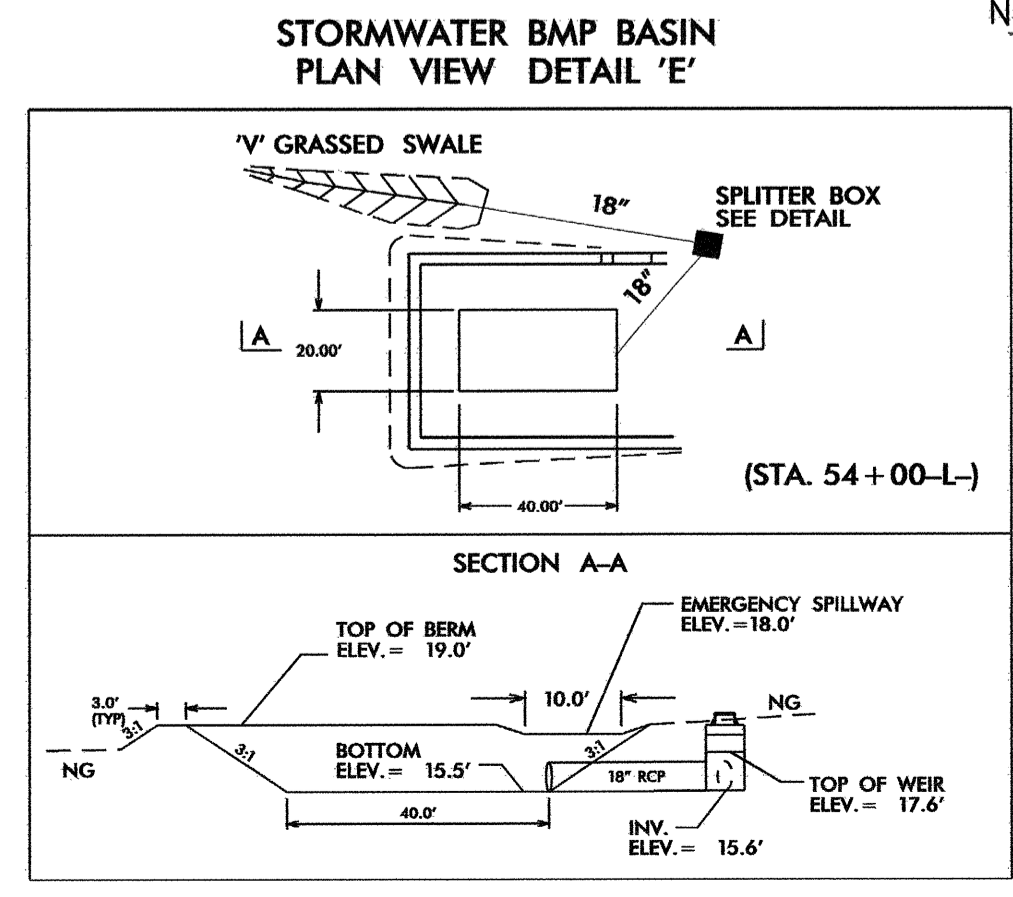
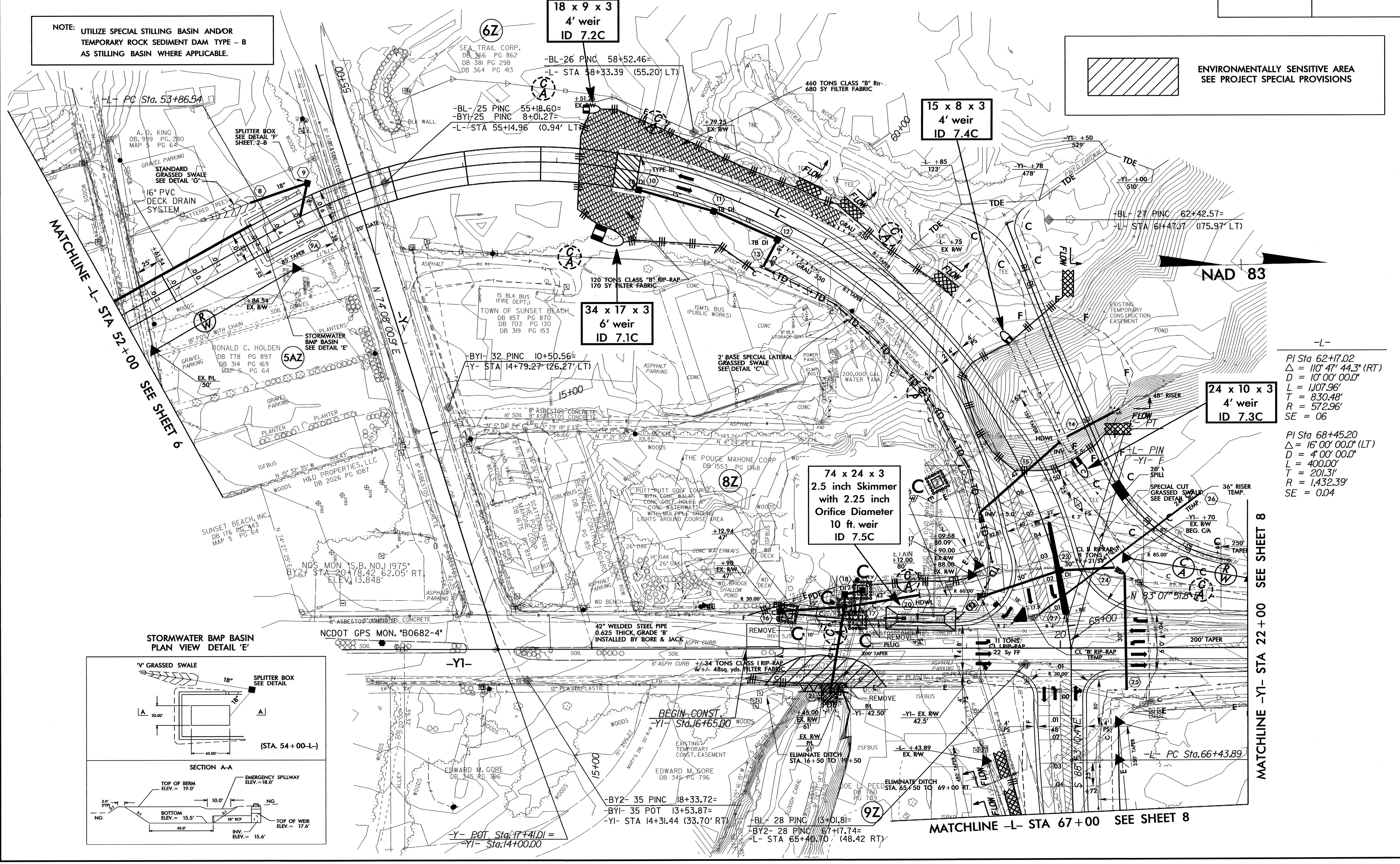

-L-
 PI Sta 62+17.02
 $\Delta = 110' 47' 44.3''$ (RT)
 $D = 10' 00' 00.0''$
 $L = 1,107.96'$
 $T = 830.48'$
 $R = 572.96'$
 $SE = 06$

-L-
 PI Sta 68+45.20
 $\Delta = 16' 00' 00.0''$ (LT)
 $D = 4' 00' 00.0''$
 $L = 400.00'$
 $T = 201.31'$
 $R = 1,432.39'$
 $SE = 0.04$

MATCHLINE -YI- STA 22+00 SEE SHEET 8

MATCHLINE -L- STA 67+00 SEE SHEET 8

PROJECT REFERENCE NO. <i>B-0682</i>	SHEET NO. EC-8/CONST.8
RW SHEET NO.	
ROADWAY DESIGN ENGINEER	HYDRAULICS ENGINEER

CLEARING AND GRUBBING
EROSION CONTROL FOR
CONSTRUCTION SHEET 8

NOTE:
PLACE TEMPORARY ROCK SEDIMENT DAMS TYPE - B
AND TEMPORARY ROCK SILT CHECKS TYPE - A AT
DRAINAGE OUTLETS.

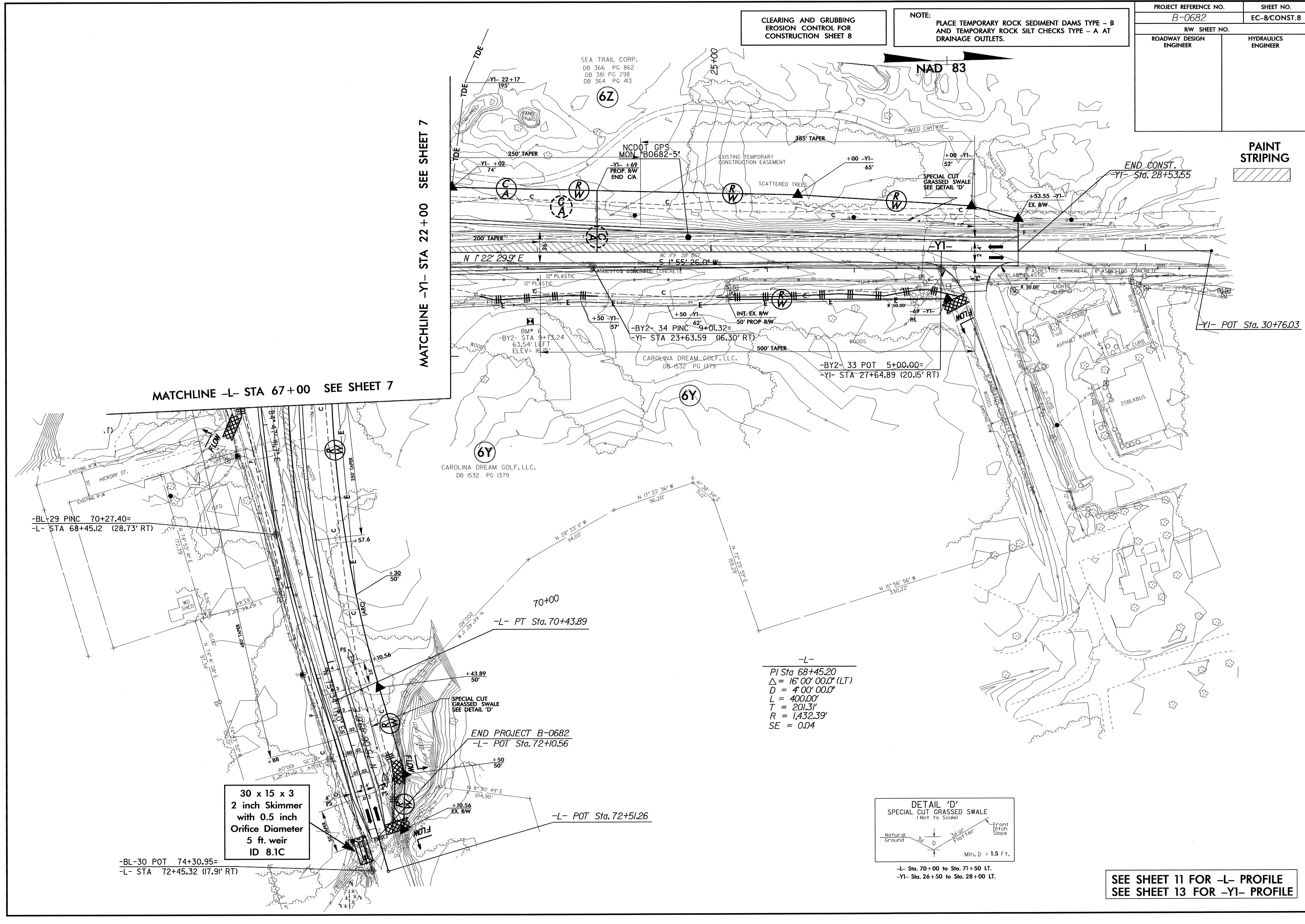

MATCHLINE -L- STA 67+00 SEE SHEET 7

MATCHLINE -YI- STA 22+00 SEE SHEET 7

-BL-29 PINC 70+27.40=
-L- STA 68+45.12 (28.73' RT)

-L- PT Sta. 70+43.89

-L-
PI Sta 68+45.20
Δ = 16' 00' 00.0" (LT)
D = 4' 00' 00.0"
L = 400.00'
T = 201.31'
R = 1,432.39'
SE = 0.04

30 x 15 x 3
2 inch Skimmer
with 0.5 inch
Orifice Diameter
5 ft. weir
ID 8.1C

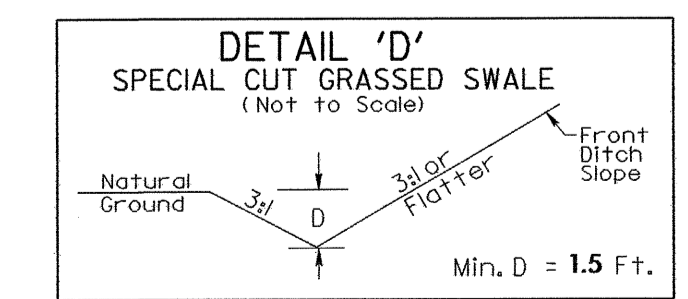

-L- Sta. 70+00 to Sta. 71+50 LT.
-YI- Sta. 26+50 to Sta. 28+00 LT.

SEE SHEET 11 FOR -L- PROFILE
SEE SHEET 13 FOR -YI- PROFILE

PAINT STRIPING

-YI- POT Sta. 30+76.03

END CONST.
-YI- Sta. 28+53.55

SEA TRAIL CORP.
DB 366 PG 862
DB 381 PG 298
DB 364 PG 413

NCDOT GPS
MON. #B0682-5

CAROLINA DREAM GOLF, L.L.C.
DB 1532 PG 1379

CAROLINA DREAM GOLF, L.L.C.
DB 1532 PG 1379

NAD 83

-BL-30 POT 74+30.95=
-L- STA 72+45.32 (17.91' RT)

-L- POT Sta. 72+51.26

END PROJECT B-0682
-L- POT Sta. 72+10.56

PROJECT REFERENCE NO. <i>B-0682</i>	SHEET NO. EC-9/CONST.4
RW SHEET NO.	
ROADWAY DESIGN ENGINEER	HYDRAULICS ENGINEER

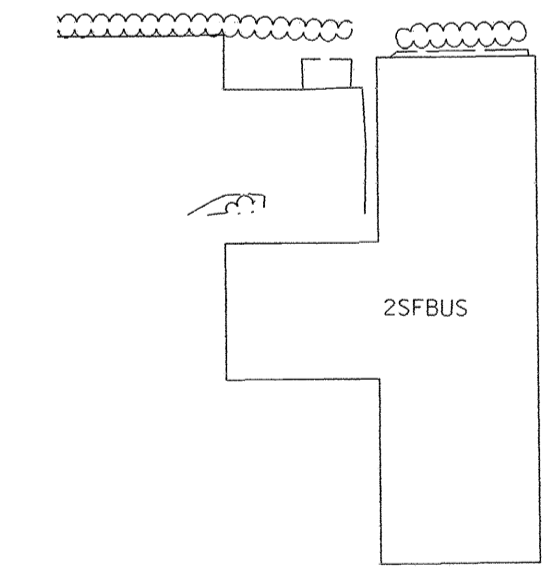
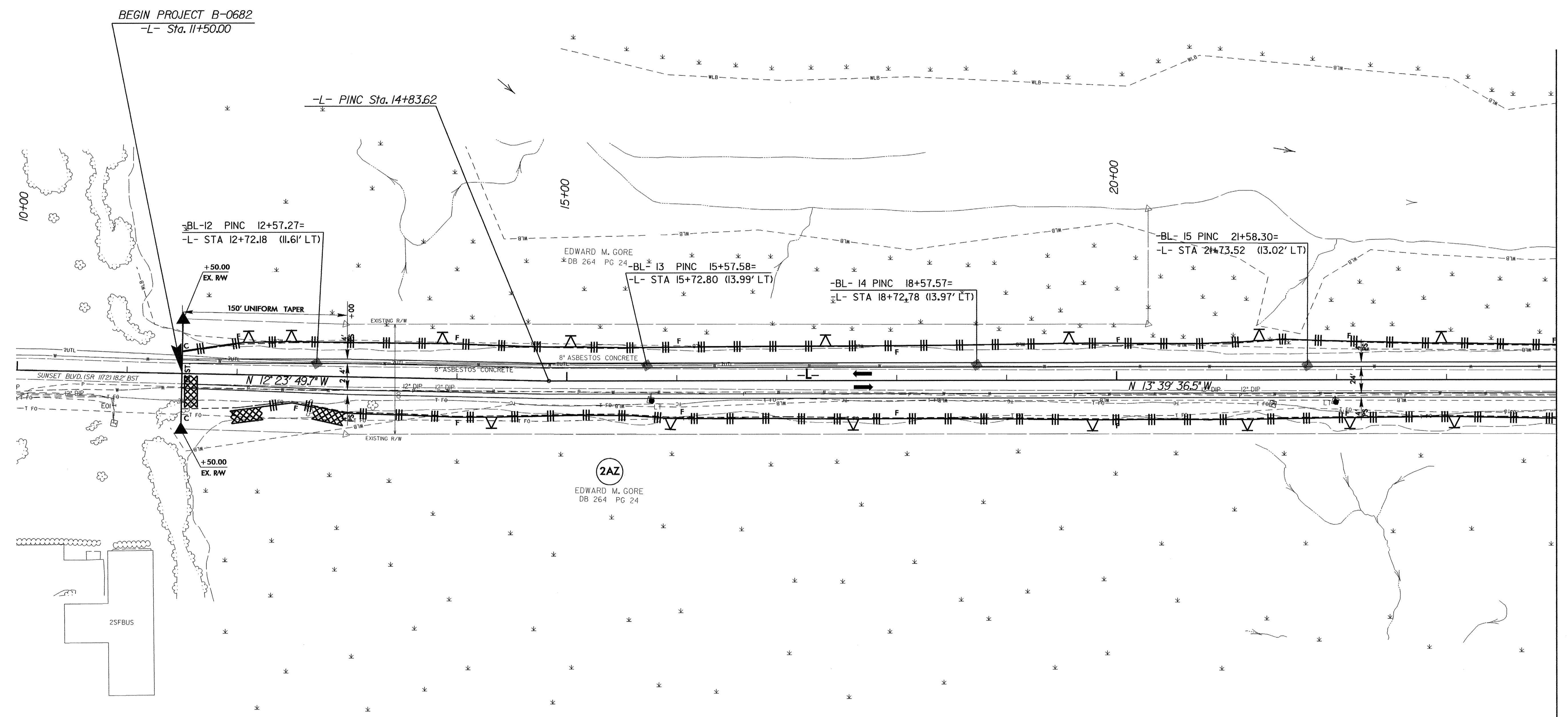
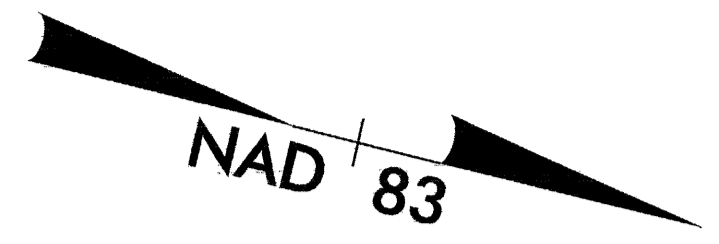

MATCHLINE -L- STA 24+00 SEE SHEET 5

SEE SHEET 9 FOR -L- PROFILE

PROJECT REFERENCE NO.		SHEET NO.	
B-0682		EC-10/CONST.5	
RW SHEET NO.			
ROADWAY DESIGN ENGINEER		HYDRAULICS ENGINEER	

NOTE:
UTILIZE SPECIAL STILLING BASIN AS STILLING BASIN WHERE APPLICABLE.

-L-
PI Sta 40+10.40
 $\Delta = 14' 00'' 31.7'' (LT)$
 $D = 2' 30'' 00.0''$
 $L = 560.35'$
 $T = 281.58'$
 $R = 2,291.83'$
 $SE = 03$

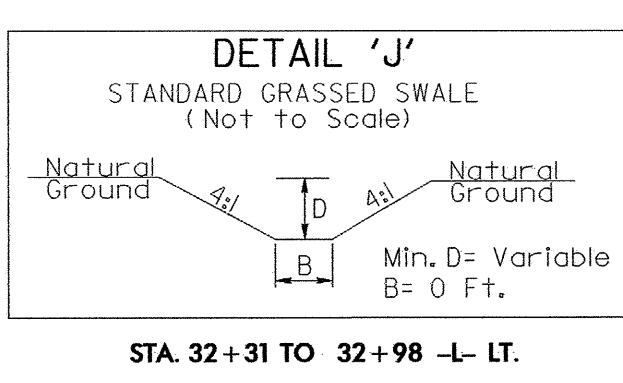
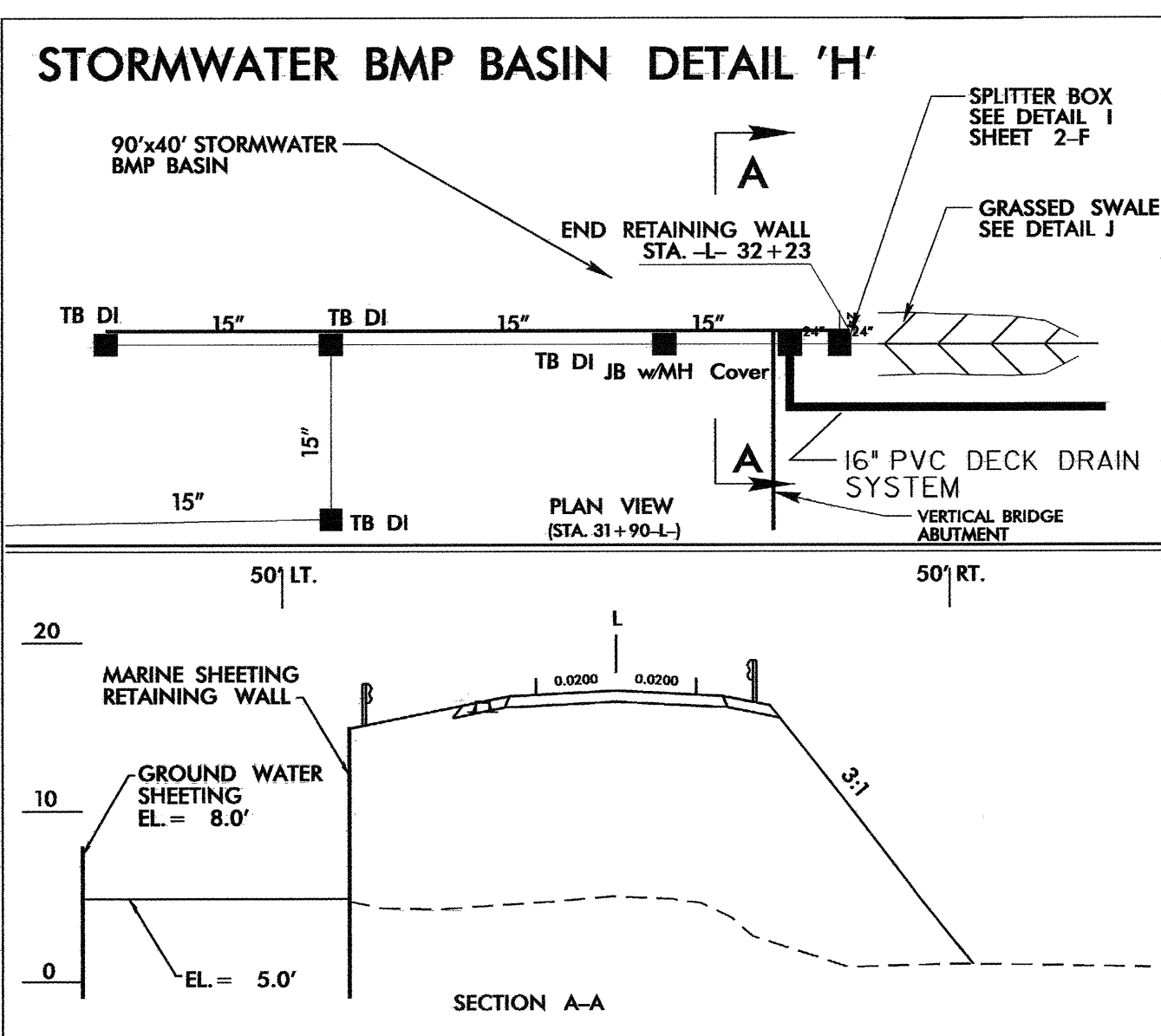
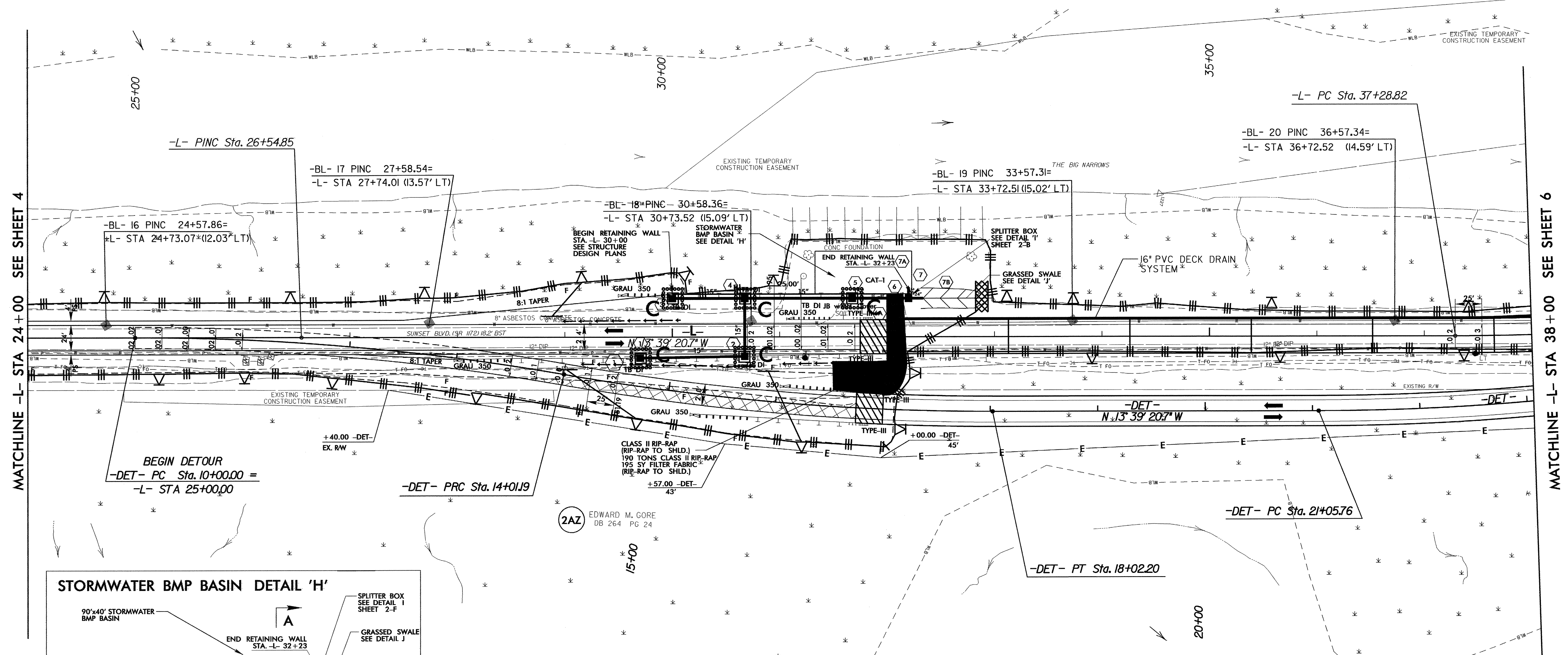
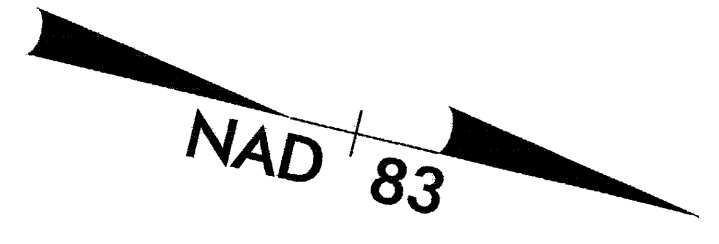

-DET-
PI Sta 12+01.11
 $\Delta = 10' 01'' 46.9'' (RT)$
 $D = 2' 30'' 00.0''$
 $L = 401.19'$
 $T = 201.11'$
 $R = 2,291.83'$
 $SE = 0.02$

-DET-
PI Sta 16+02.21
 $\Delta = 10' 01'' 31.1'' (LT)$
 $D = 2' 30'' 00.0''$
 $L = 401.01'$
 $T = 201.02'$
 $R = 2,291.83'$
 $SE = 0.02$

-DET-
PI Sta 23+05.19
 $\Delta = 9' 56'' 46.1'' (LT)$
 $D = 2' 30'' 00.0''$
 $L = 397.85'$
 $T = 199.42'$
 $R = 2,291.83'$
 $SE = 0.02$

MATCHLINE -L- STA 24+00 SEE SHEET 4

MATCHLINE -L- STA 38+00 SEE SHEET 6

PROJECT REFERENCE NO. B-0682		SHEET NO. EC-11/CONST.6	
RW SHEET NO.			
ROADWAY DESIGN ENGINEER		HYDRAULICS ENGINEER	

NOTE:
UTILIZE SPECIAL STILLING BASIN AS STILLING BASIN WHERE APPLICABLE.

-L-	-DET-	-L-
PI Sta 40+10.40 Δ = 14° 00' 31.7" (LT) D = 2' 30' 00.0" L = 560.35' T = 281.58' R = 2,291.83' SE = 03	PI Sta 23+05.19 Δ = 9° 56' 46.1" (LT) D = 2' 30' 00.0" L = 397.85' T = 199.42' R = 2,291.83' SE = 02	PI Sta 27+04.83 Δ = 10° 02' 06.8" (RT) D = 2' 30' 00.0" L = 401.41' T = 201.22' R = 2,291.83' SE = 02

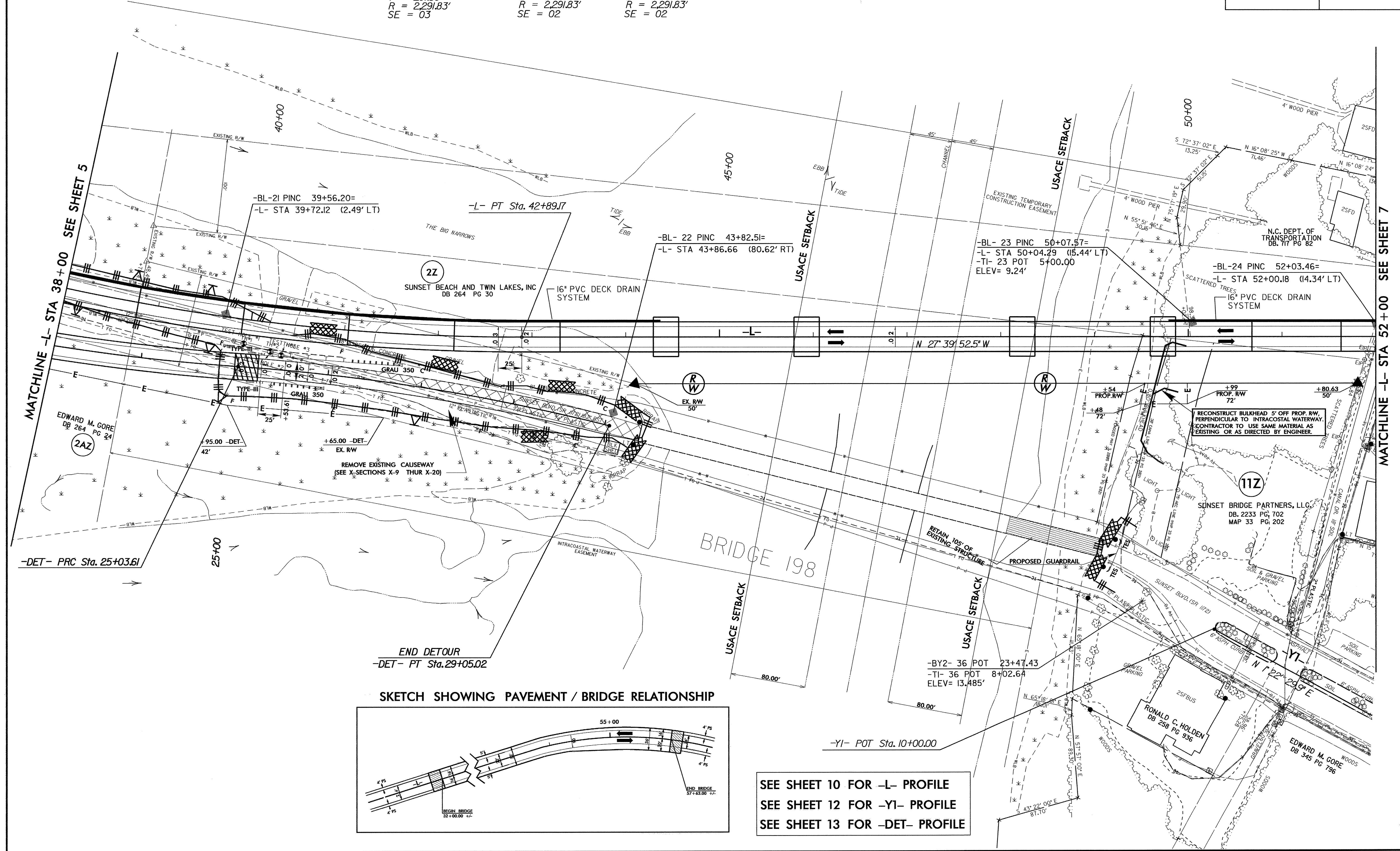
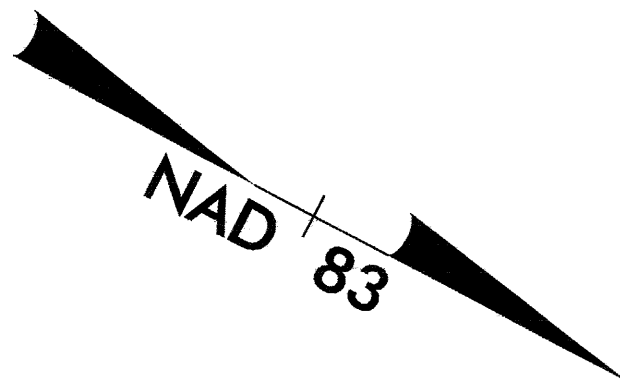

MATCHLINE -L- STA 38+00 SEE SHEET 5

MATCHLINE -L- STA 52+00 SEE SHEET 7

SKETCH SHOWING PAVEMENT / BRIDGE RELATIONSHIP

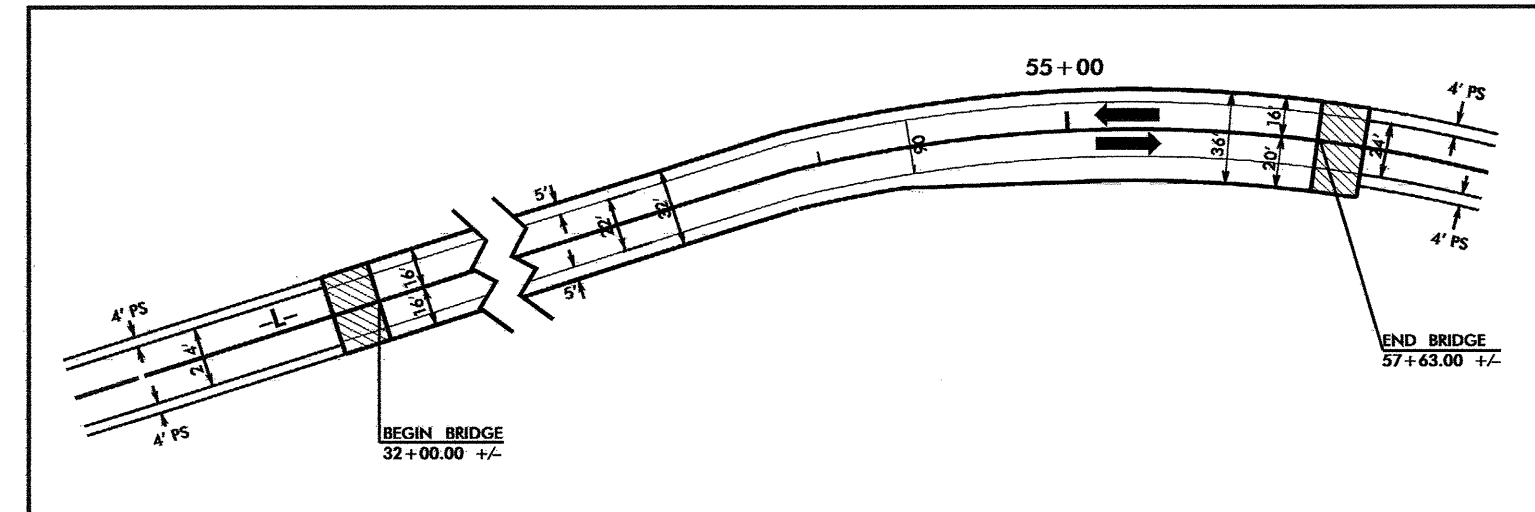

SEE SHEET 10 FOR -L- PROFILE
SEE SHEET 12 FOR -Y1- PROFILE
SEE SHEET 13 FOR -DET- PROFILE

PROJECT REFERENCE NO.	SHEET NO.
B-0682	EC-12/CONST.7
RW SHEET NO.	
ROADWAY DESIGN ENGINEER	HYDRAULICS ENGINEER

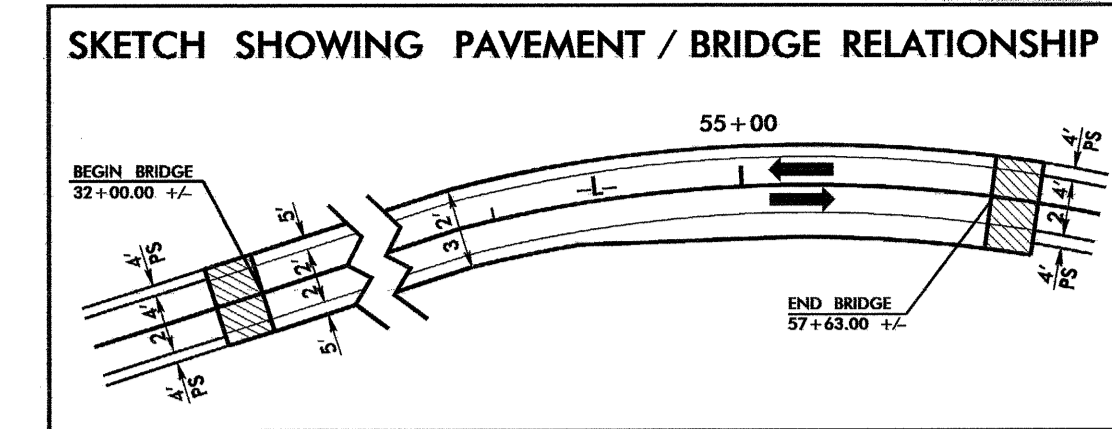
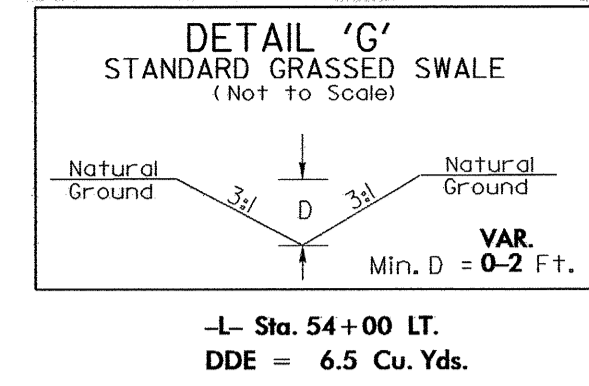
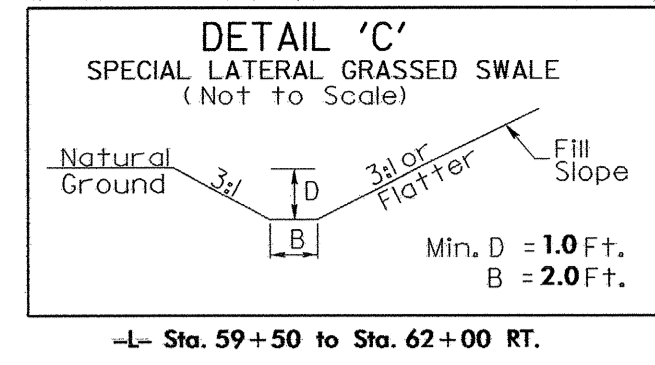
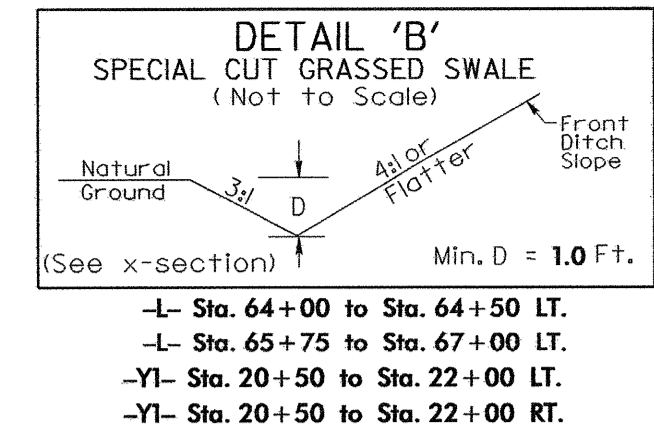
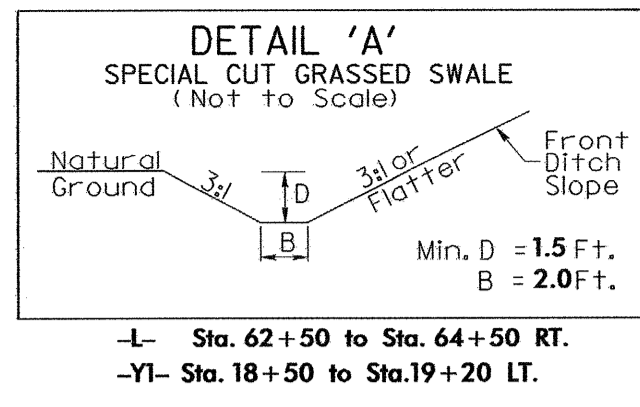

NOTE: UTILIZE SPECIAL STILLING BASIN AND/OR TEMPORARY ROCK SEDIMENT DAM TYPE - B AS STILLING BASIN WHERE APPLICABLE.

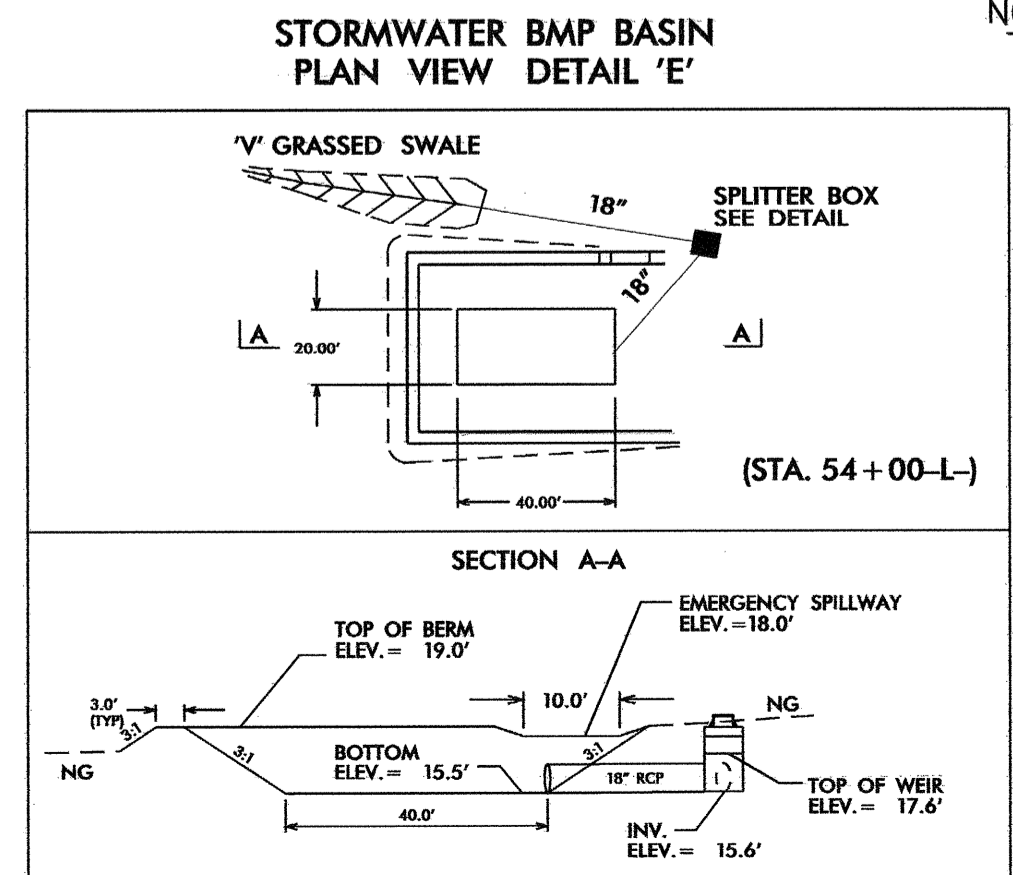
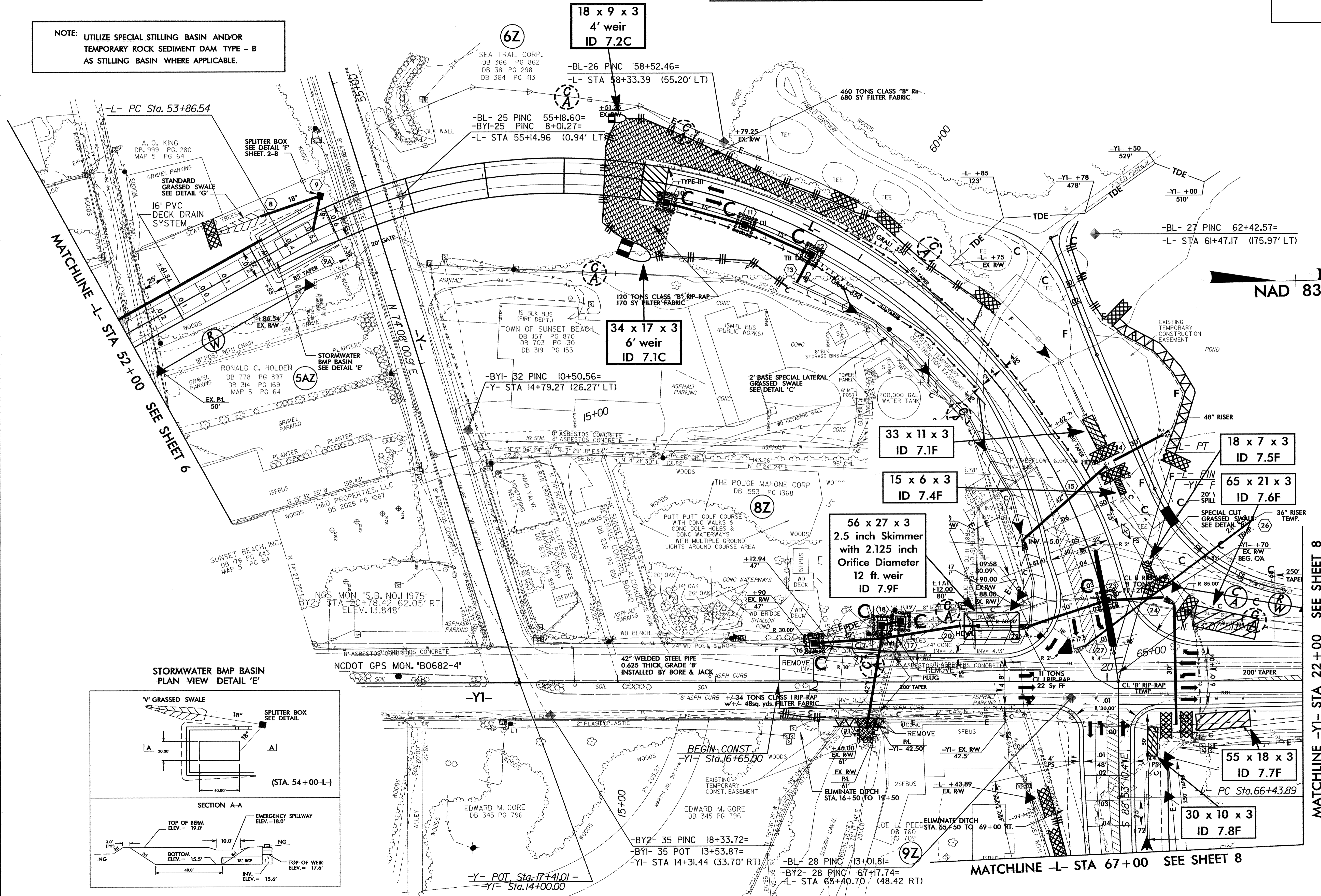

-L-
PI Sta 62+17.02
 $\Delta = 110' 47' 44.3''$ (RT)
D = 10' 00' 00.0"
L = 1,107.96'
T = 830.48'
R = 572.96'
SE = 06

PI Sta 68+45.20
 $\Delta = 16' 00' 00.0''$ (LT)
D = 4' 00' 00.0"
L = 400.00'
T = 201.31'
R = 1,432.39'
SE = 0.04

MATCHLINE -YI- STA 22+00 SEE SHEET 8

MATCHLINE -L- STA 67+00 SEE SHEET 8

PROJECT REFERENCE NO.	SHEET NO.
B-0682	EC-13/CONST.8
RW SHEET NO.	
ROADWAY DESIGN ENGINEER	HYDRAULICS ENGINEER

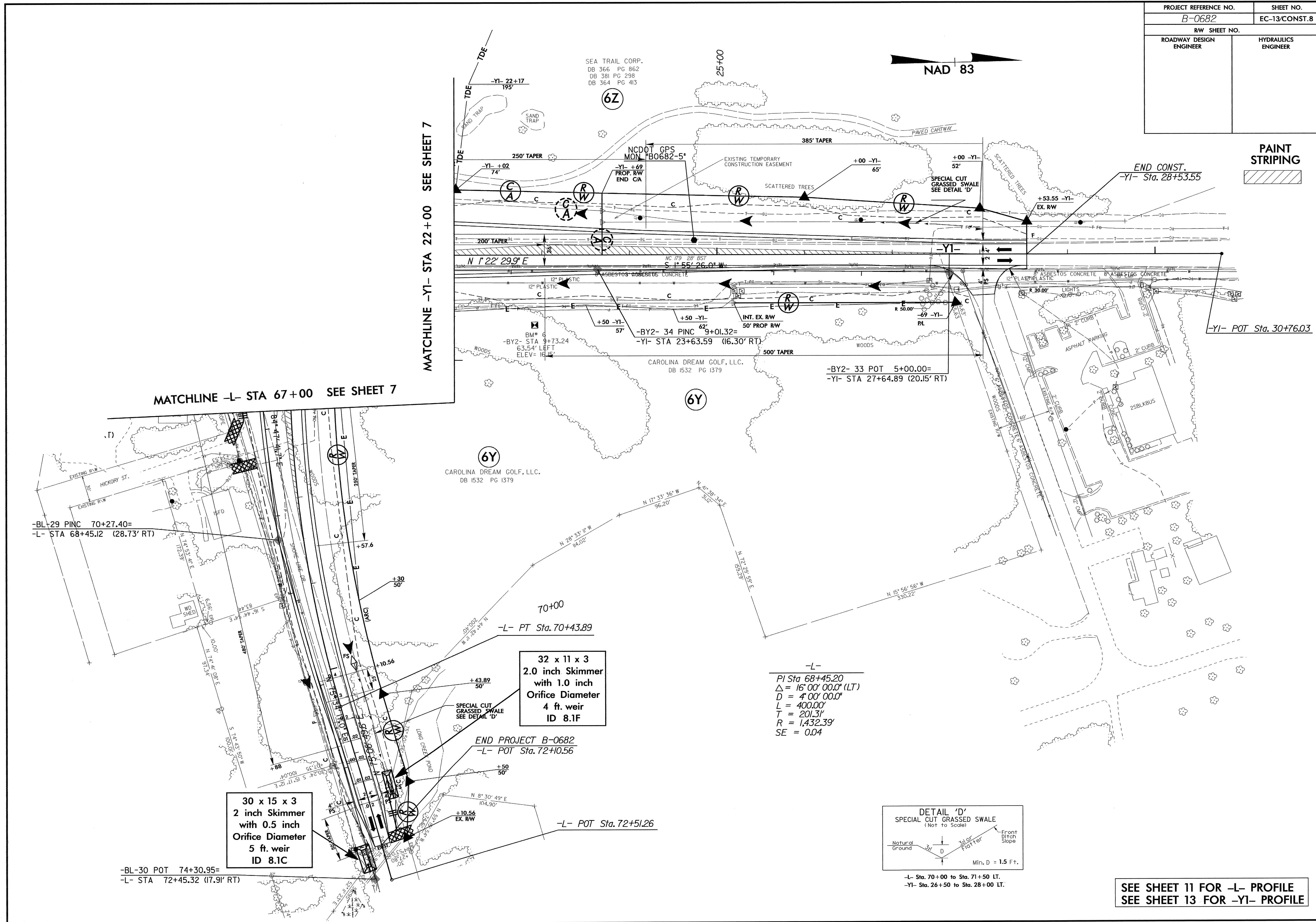

NAD 83

PAINT STRIPING

MATCHLINE -YI- STA 22+00 SEE SHEET 7

MATCHLINE -L- STA 67+00 SEE SHEET 7

32 x 11 x 3
2.0 inch Skimmer
with 1.0 inch
Orifice Diameter
4 ft. weir
ID 8.1F

30 x 15 x 3
2 inch Skimmer
with 0.5 inch
Orifice Diameter
5 ft. weir
ID 8.1C

-L-
PI Sta 68+45.20
Δ = 16' 00" 00.0" (LT)
D = 4' 00" 00.0"
L = 400.00'
T = 201.31'
R = 1,432.39'
SE = 0.04

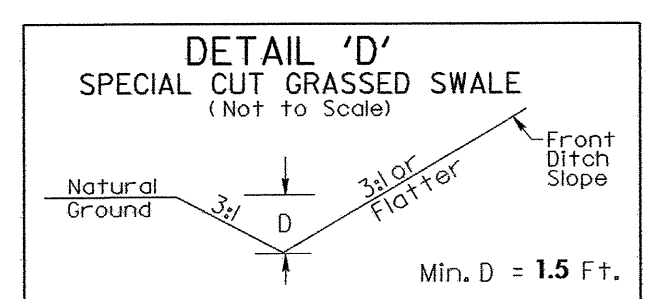

SEE SHEET 11 FOR -L- PROFILE
SEE SHEET 13 FOR -YI- PROFILE

-BL-29 PINC 70+27.40=
-L- STA 68+45.12 (28.73' RT)

-L- PT Sta. 70+43.89

END PROJECT B-0682
-L- POT Sta. 72+10.56

-L- POT Sta. 72+51.26

-BL-30 POT 74+30.95=
-L- STA 72+45.32 (17.91' RT)

SEA TRAIL CORP.
DB 366 PG 862
DB 381 PG 298
DB 364 PG 413

CAROLINA DREAM GOLF, LLC.
DB 1532 PG 1379

CAROLINA DREAM GOLF, LLC.
DB 1532 PG 1379

NCDOT GPS
MON. B0682-5*

SPECIAL CUT
GRASSED SWALE
SEE DETAIL 'D'

END CONST.
-YI- Sta. 28+53.55

-YI- POT Sta. 30+76.03

-BY2- 34 PINC 9+01.32=
-YI- STA 23+63.59 (16.30' RT)

-BY2- 33 POT 5+00.00=
-YI- STA 27+64.89 (20.15' RT)

CAROLINA DREAM GOLF, LLC.
DB 1532 PG 1379

6Y

6Y

6Z

6Z

6Z

6Z

6Z

6Z

6Z

6Z

6Z

6Z

6Z

6Z

6Z

6Z

6Z

6Z

6Z

6Z

6Z

PROJECT REFERENCE NO. B-0682		SHEET NO. EC-14	
RW SHEET NO.			
ROADWAY DESIGN ENGINEER		HYDRAULICS ENGINEER	

PLANTING DETAILS

DIBBLE PLANTING METHOD USING THE KBC PLANTING BAR

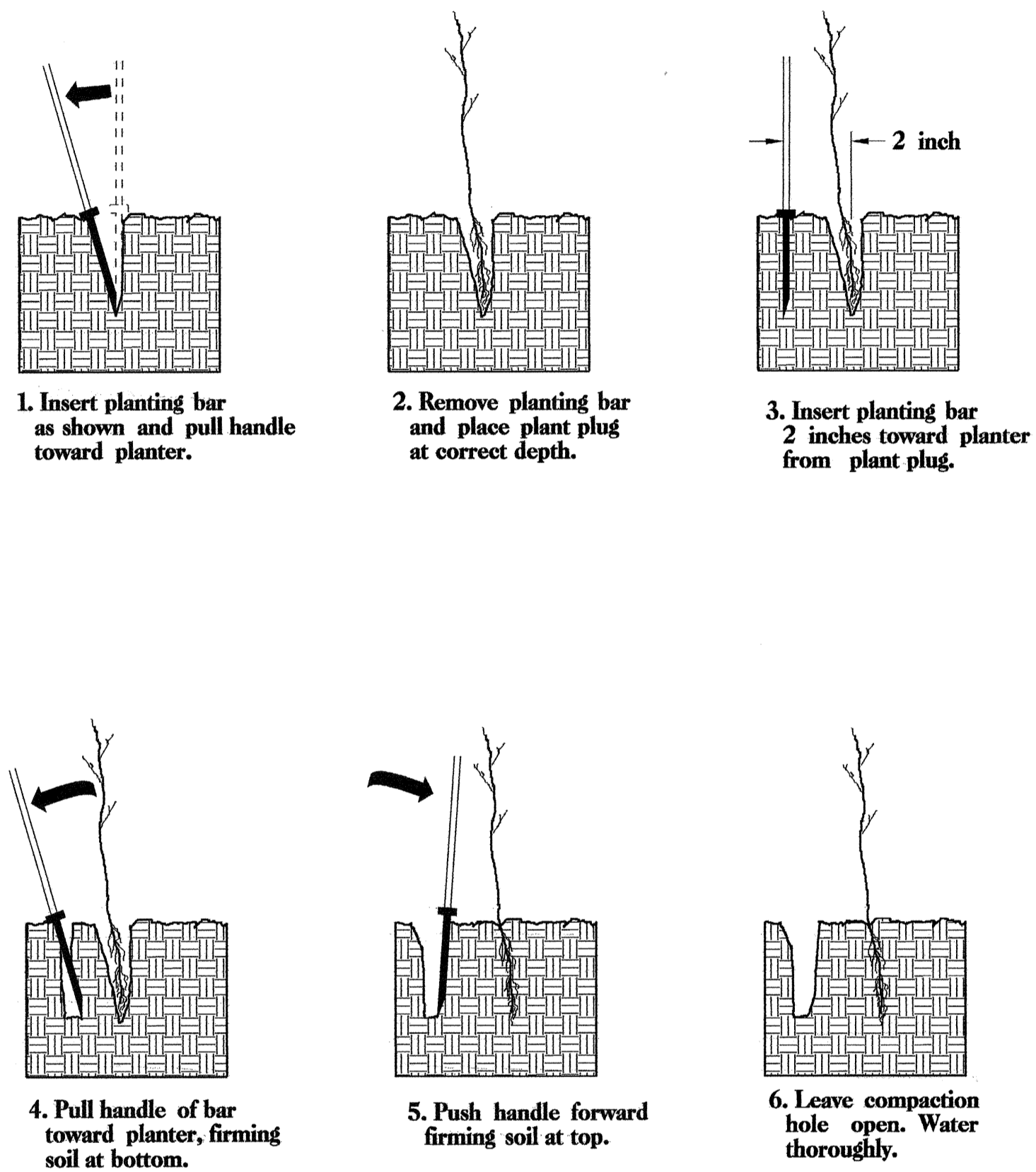

PLANTING NOTES:

PLANTING BAG
During planting, plant plugs shall be kept in a moist canvas bag or similar container to prevent the root systems from drying.

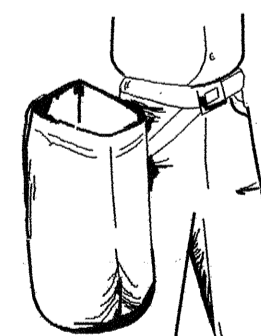

KBC PLANTING BAR
Planting bar shall have a blade with a triangular cross section, and shall be 12 inches long, 4 inches wide and 1 inch thick at center.



WETLAND GRASS PLANTING

- WETLAND GRASS SPECIES SHALL BE PLANTED 2 FT. TO 4 FT. ON CENTER, RANDOM SPACING, AVERAGING 3 FT. ON CENTER, APPROXIMATELY 4840 PLANTS PER ACRE.

WETLAND GRASS PLANTING

MIXTURE, TYPE, SIZE, AND FURNISH SHALL CONFORM TO THE FOLLOWING:

100% SPARTINA ALTERNIFLORA SMOOTH CORDGRASS 2 in PEAT POT

WETLAND GRASS PLANTING DETAIL SHEET

N.C.D.O.T. - ROADSIDE ENVIRONMENTAL UNIT