

TEMPORARY PAVEMENT MARKING SCHEDULE



SYMBOL	DESCRIPTION	PAY ITEM QUANTITY BREAKDOWN	TOTAL QUANTITY	
PAVEMENT MARKINGS				
PAINT (12")				
P1	WHITE GORELINE (1X)	1692 LF	1692 LF	
PAINT (16")				
P3	WHITE LINE, RR X (1X)	516 LF	516 LF	
PAINT (24") TEMPORARY PAVEMENT MARKING				
P4	WHITE STOPBAR (1X)	556 LF	844 LF	
P5	WHITE CROSSWALK LINE (1X)	288 LF		
PAINT (4")				
PA	WHITE EDGELINE (1X)	68614 LF	158961 LF	
PC	10 FT. WHITE SKIP (1X)	3479 LF		
PD	2 FT. WHITE MINISKIP (1X)	498 LF		
PE	WHITE SOLID LANE LINE (1X)	3088 LF		
PF	10 FT. YELLOW SKIP (1X)	1534 LF		
PH	YELLOW SINGLE CENTER (1X)	9512 LF		
PI	YELLOW DOUBLE CENTER (1X)	72236 LF		
PAINT (8")				
PV	YELLOW DIAGONAL (1X)	1736 LF		
PAINTMARKING CHARACTERS				
QI	ALPHANUMERIC CHAR. (1X)	22 EA	22 EA	
PAINTMARKING SYMBOLS				
QA	LEFT TURN ARROW (1X)	16 EA	36 EA	
QB	RIGHT TURN ARROW (1X)	16 EA		
QC	STRAIGHT ARROW (1X)	4 EA		
MARKERS				
TEMPORARY RAISED PAVEMENT MARKERS				
MH	YELLOW & YELLOW	68 EA	155 EA	
MI	CRYSTAL & RED	87 EA		

APPLY ONE APPLICATION AT 15 MILS WET. IF THE TEMPORARY TRAFFIC PATTERN WILL LAST LONGER THAN SIX MONTHS, APPLY A SECOND APPLICATION OF PAINT SIX MONTHS AFTER THE INITIAL APPLICATION. PAY ITEM QUANTITY BREAKDOWN INCLUDES UP TO FOUR APPLICATIONS.

FINAL PAVEMENT MARKING SCHEDULE

SYMBOL	DESCRIPTION	PAY ITEM QUANTITY BREAKDOWN	TOTAL QUANTITY
PAVEMENT MARKINGS			
THERMOPLASTIC (16", 120 MILS)			
T1	WHITE LINE, RR CROSSB	172 LF	172 LF
THERMOPLASTIC (24", 120 MILS)			
T2	WHITE STOPBAR	175 LF	367 LF
T3	WHITE CROSSWALK LINE	192 LF	
THERMOPLASTIC (4", 120 MILS)			
TC	10 FT. WHITE SKIP	4342 LF	26894 LF
TD	2 FT. WHITE MINISKIP	92 LF	
TE	WHITE SOLID LANE LINE	599 LF	
TF	10 FT. YELLOW SKIP	2483 LF	
TH	YELLOW SINGLE CENTER	9932 LF	
TI	YELLOW DOUBLE CENTER	9446 LF	
THERMOPLASTIC (4", 90 MILS)			
TA	WHITE EDGELINE	16699 LF	16699 LF
THERMOPLASTIC (8", 90 MILS)			
TP	WHITE GORELINE	708 LF	1710 LF
TQ	WHITE DIAGONAL	154 LF	
TT	YELLOW DIAGONAL	848 LF	
THERMOPLASTIC PAVEMENT MARKING CHARACTER (120 MILS)			
UI	ALPHANUMERIC CHAR.	12 EA	12 EA
THERMOPLASTIC PAVEMENT MARKING SYMBOLS (90 MILS)			
UA	LEFT TURN ARROW	41 EA	45 EA
UB	RIGHT TURN ARROW	4 EA	
MARKERS			
PERMANENT RAISED PAVEMENT MARKERS			
MA	YELLOW & YELLOW	181 EA	570 EA
MB	CRYSTAL & RED	389 EA	

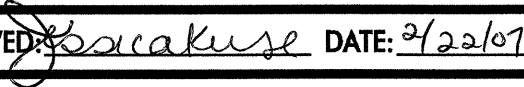
22-FEB-2007 15:23
 \\dot\dfs0041\work\projects-u3823\traffic\traffic\top\project a\PMP\U3823A.TC.PMP_01.dgn
 rmgarrett

APPROVED:  DATE: 2/23/07		TEMPORARY / FINAL PAVEMENT MARKING SCHEDULES	
	SCALE: NONE	REVISIONS	
	DATE: 01/07		
	DWG. BY: RMG		
	DESIGN BY: RMG		
REVIEWED BY: JDK			
		CADD FILE	

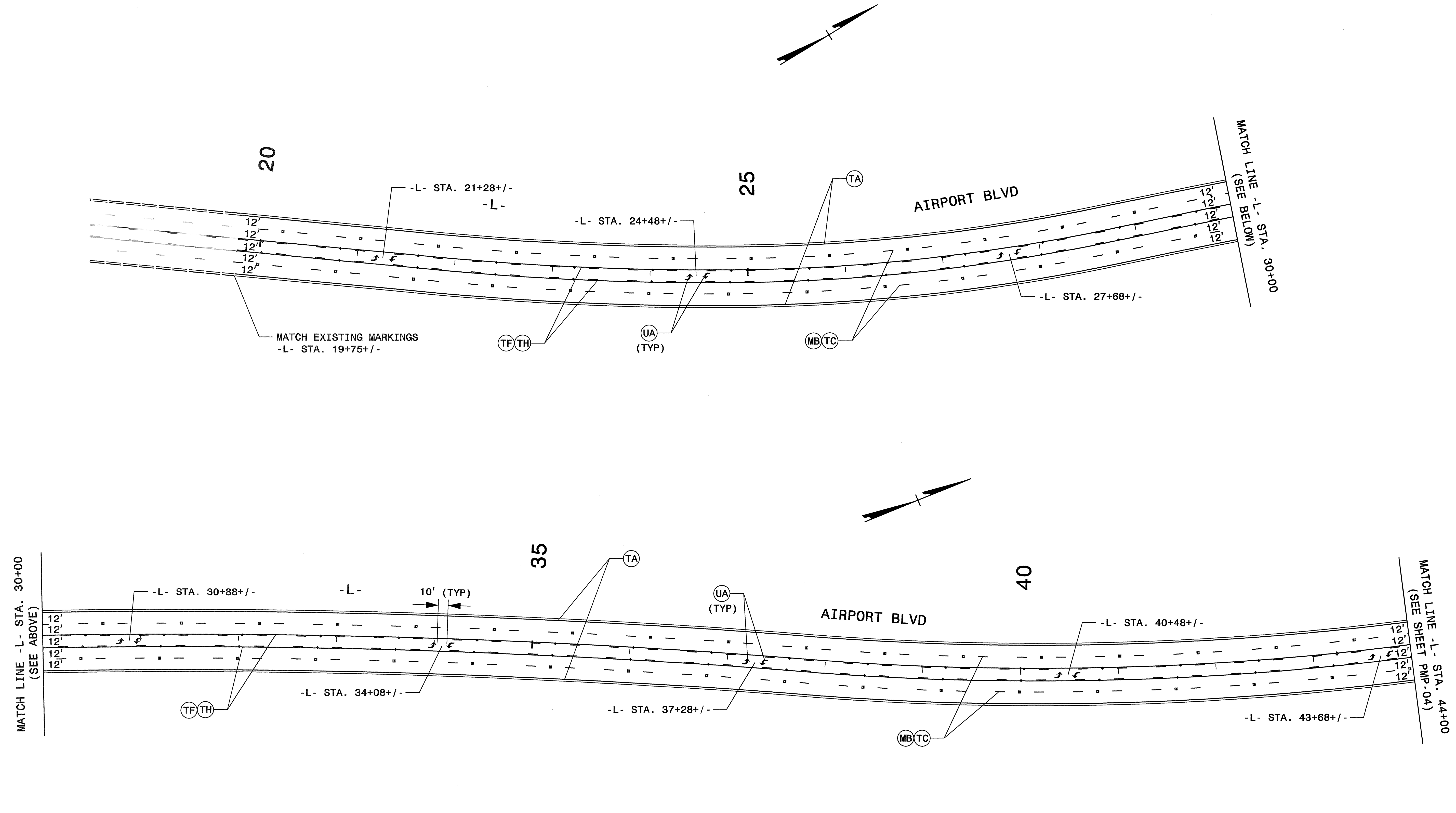

22-FEB-2007 15:24
 C:\projects\proj\traffic\traffic\top\project\pmp\U3823A_TC_PMP_02.dgn
 rmgarratt AT 1/22/07

NOTES:

PAVEMENT MARKINGS TO BE MARKED ACCORDING TO ROADWAY STANDARD DRAWINGS UNLESS OTHERWISE NOTED IN PLANS.

MARKERS ARE TO BE SPACED ACCORDING TO THE ROADWAY STANDARD DRAWINGS.

APPROVED: *Jessica D. Kuse* DATE: 2/22/07

SEAL

FINAL PAVEMENT MARKINGS		REVISIONS
SCALE:	NONE	
DATE:	01/07	
DWG. BY:	RMG	
DESIGN BY:	RMG	
REVIEWED BY:	JDK	

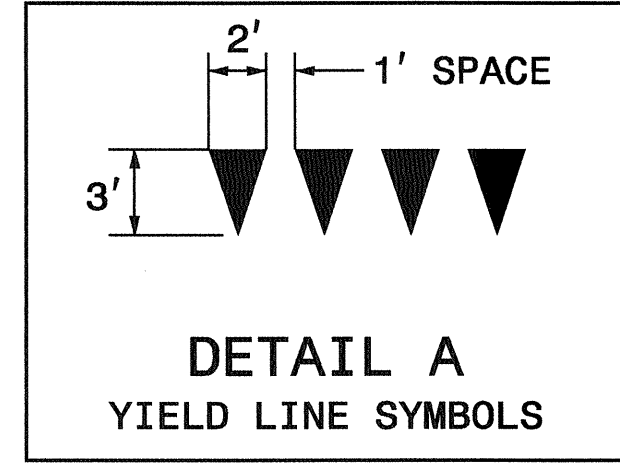
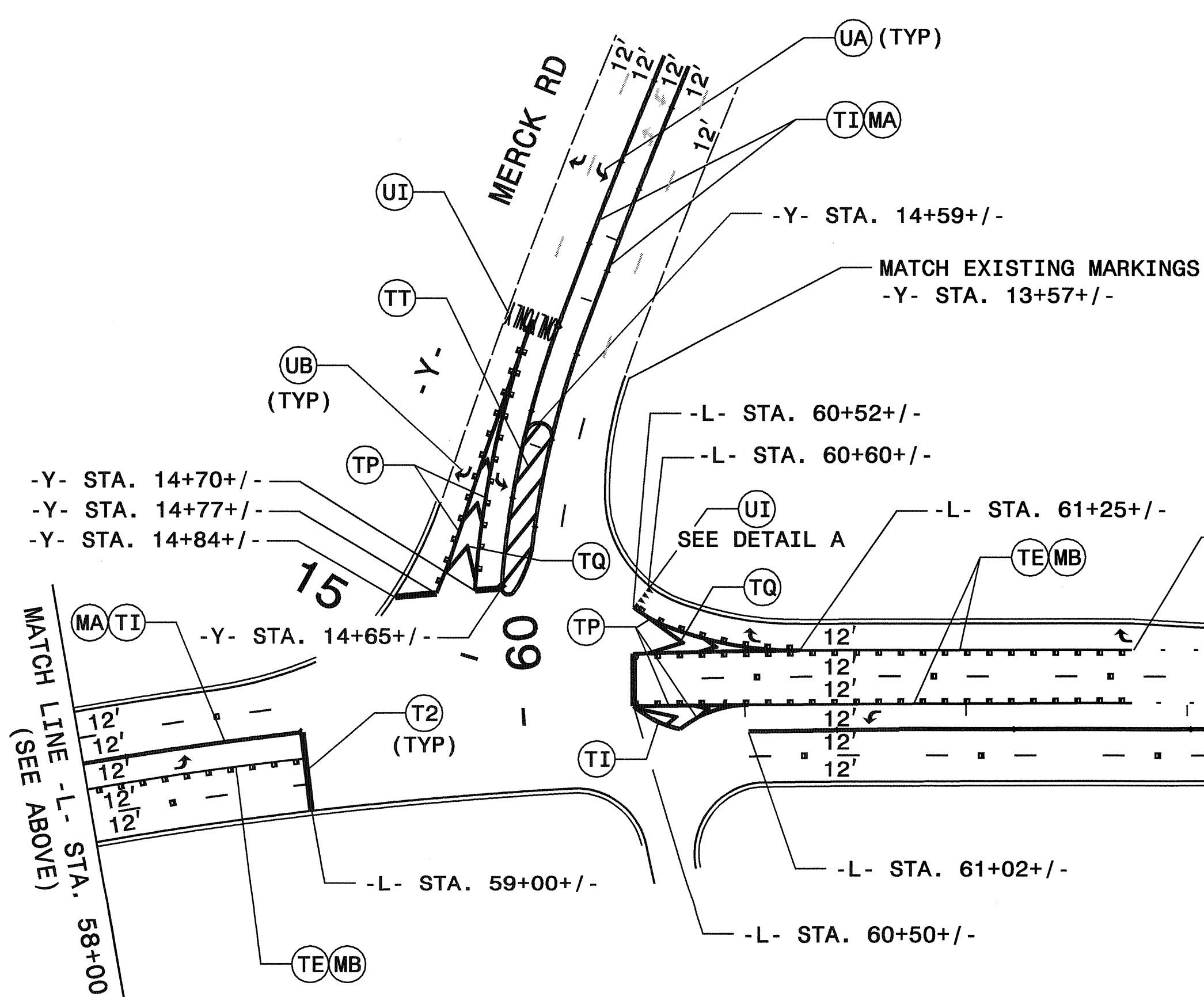
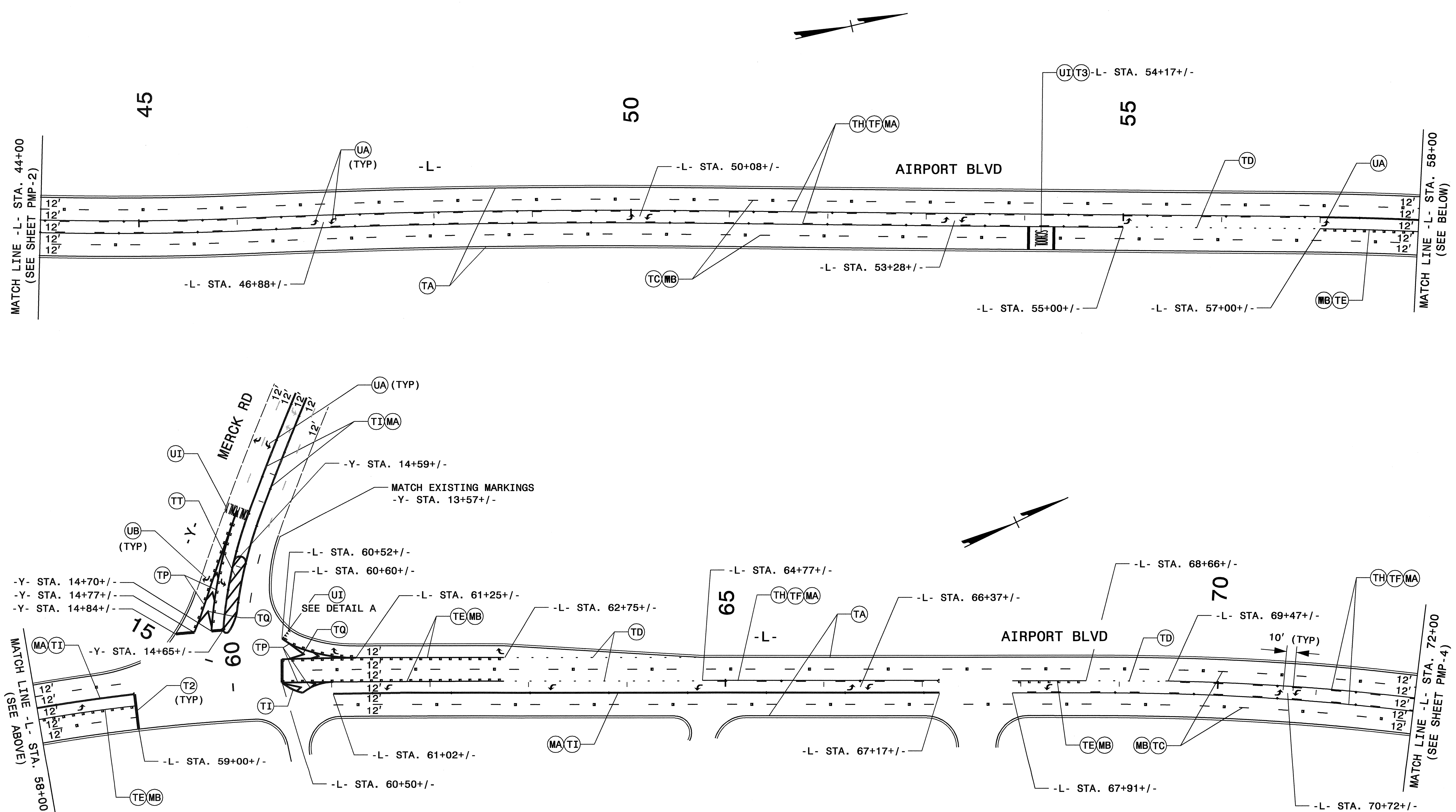

NOTES:

PAVEMENT MARKINGS TO BE MARKED ACCORDING TO ROADWAY STANDARD DRAWINGS UNLESS OTHERWISE NOTED IN PLANS.

MARKERS ARE TO BE SPACED ACCORDING TO THE ROADWAY STANDARD DRAWINGS.

APPROVED: *Jessica Kuse* DATE: 2/22/07

SEAL

FINAL PAVEMENT MARKINGS		REVISIONS
SCALE: NONE	DATE: 01/07	
DWG. BY: RMG	DESIGN BY: RMG	
REVIEWED BY: JDK		

22-FEB-2007 15:24
 C:\pmp\4611\proj\traffic\trafficcontrol\top\project a\pmp\U3823A_TC_PMP_03.dgn
 RMG:R11 AT:WZ:022207

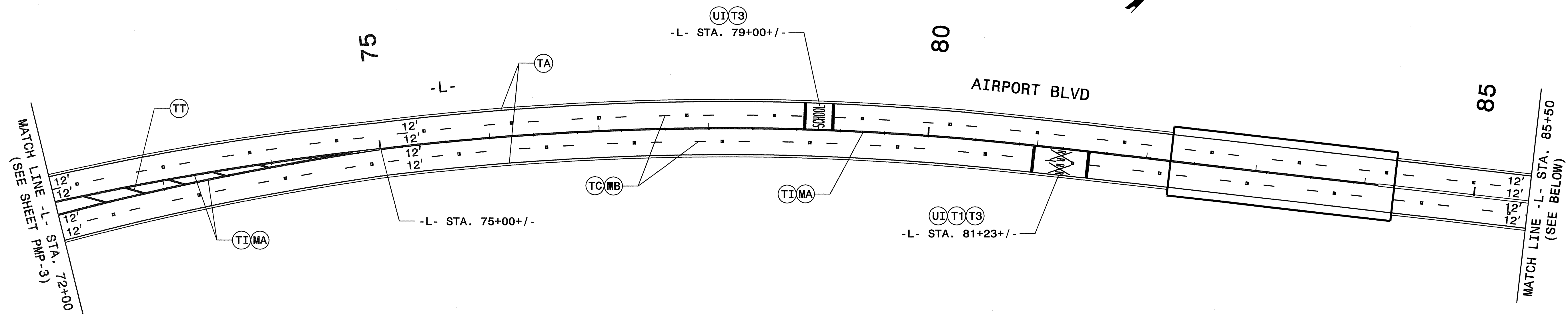

* RR STOP BAR TO BE PLACED ACCORDING TO ROADWAY STANDARD DRAWING 1205.11, SHEET 1 OF 4

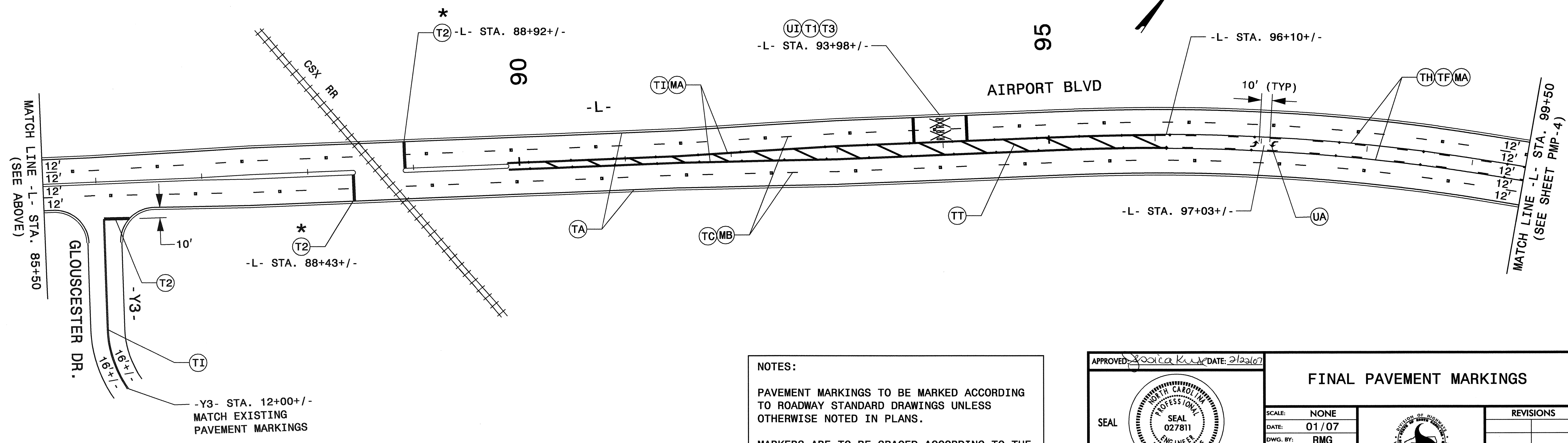

NOTES:
 PAVEMENT MARKINGS TO BE MARKED ACCORDING TO ROADWAY STANDARD DRAWINGS UNLESS OTHERWISE NOTED IN PLANS.
 MARKERS ARE TO BE SPACED ACCORDING TO THE ROADWAY STANDARD DRAWINGS.

APPROVED: *Jessica K. Kuss* DATE: 2/23/07

SEAL

FINAL PAVEMENT MARKINGS		REVISIONS
SCALE:	NONE	
DATE:	01/07	
DWG. BY:	RMG	
DESIGN BY:	RMG	
REVIEWED BY:	JDK	

22-FEB-2007 15:24
 \\dot\desr001\proj\top\projects-u\3823\traffic\traffic\control\top\project a\pmp\U3823A_TC.PMP_04.dgn
 rmgarrett
 W: 2222291

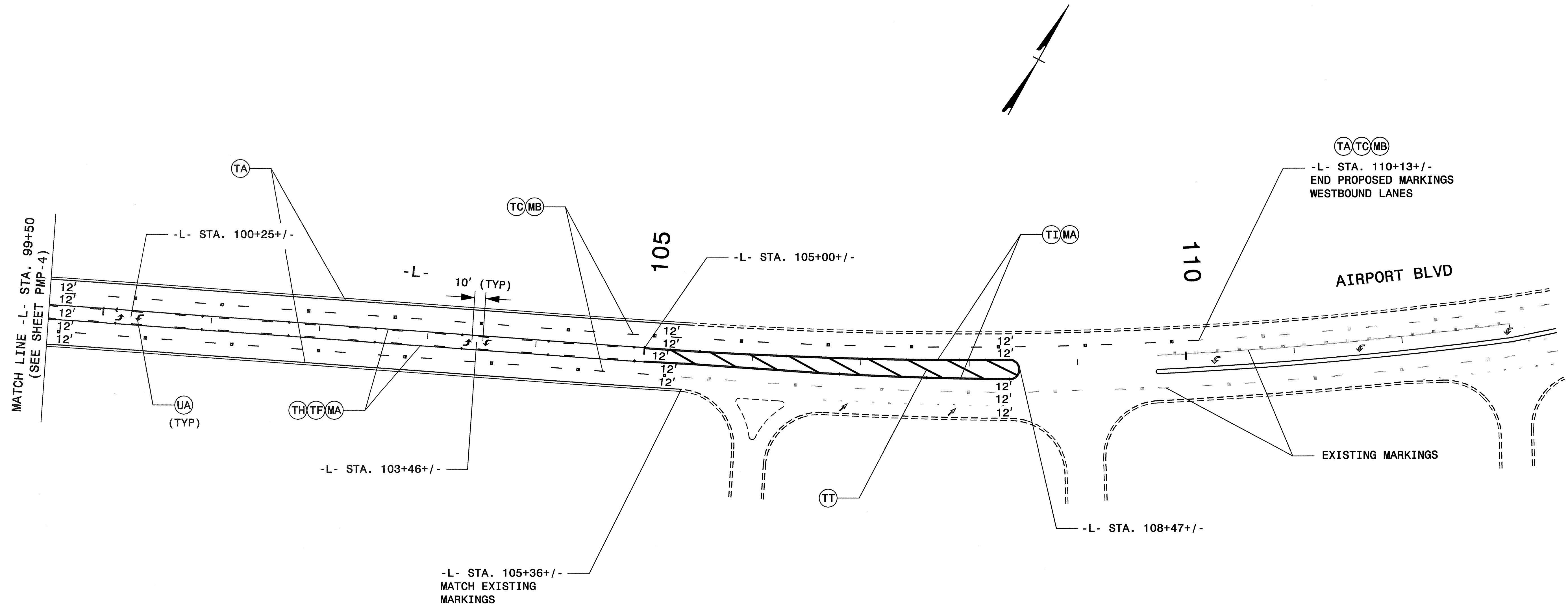

22-FEB-2007 15:25
 \\dot\cfr\oc\10\proj\110\proj\110\traffic\traffic\control\top\project a\pmp\U3823A.TC.PMP.05.dgn
 rmgarratt AT WZ 122229j

NOTES:

PAVEMENT MARKINGS TO BE MARKED ACCORDING TO ROADWAY STANDARD DRAWINGS UNLESS OTHERWISE NOTED IN PLANS.

MARKERS ARE TO BE SPACED ACCORDING TO THE ROADWAY STANDARD DRAWINGS.

APPROVED: *Jessica Kuse* DATE: 2/22/07

SEAL

FINAL PAVEMENT MARKINGS	
SCALE: NONE	REVISIONS
DATE: 01/07	
DWG. BY: RMG	
DESIGN BY: RMG	
REVIEWED BY: JDK	

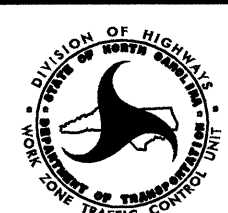

CADD FILE