

CONTRACT: C201446 TIP PROJECT B-4299

See Sheet 1-A For Index of Sheets
See Sheet 1-B For Conventional Symbols

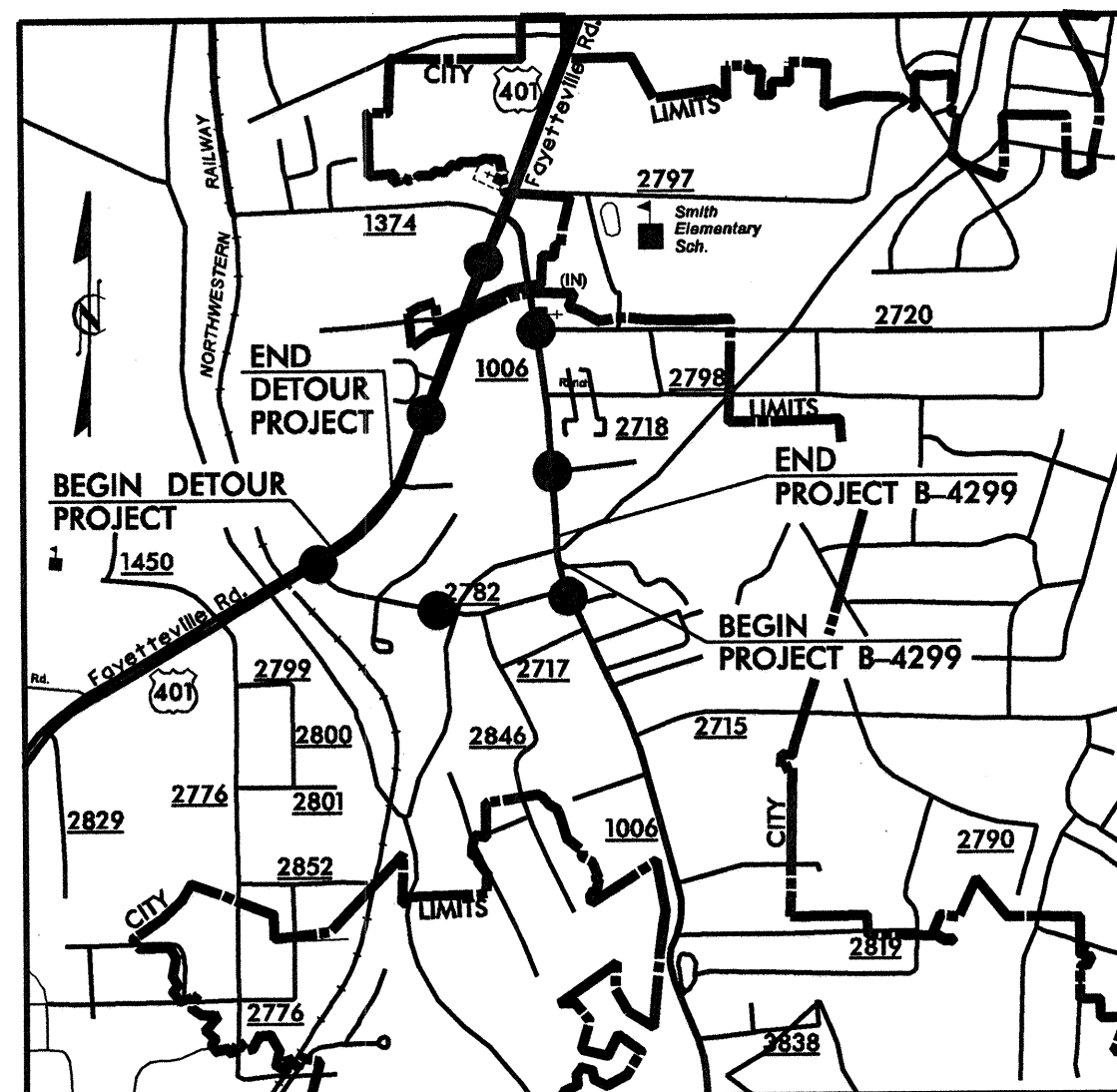

●●●●● DENOTES OFFSITE DETOUR
VICINITY MAP

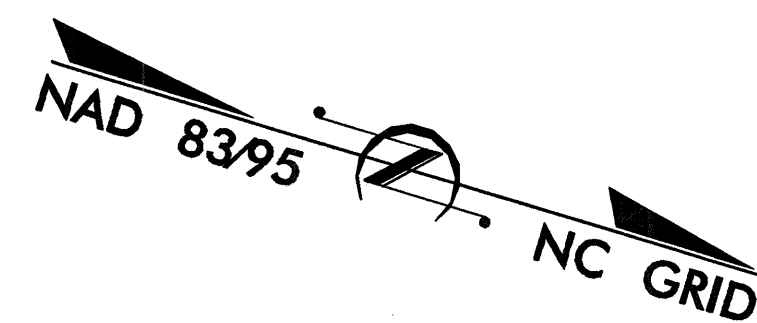

STATE OF NORTH CAROLINA
DIVISION OF HIGHWAYS

WAKE COUNTY

LOCATION: BRIDGE NO. 255 ON SR 1006 OVER AN UNNAMED TRIBUTARY TO SWIFT CREEK

TYPE OF WORK: GRADING, PAVING, DRAINAGE, SIGNALS, AND STRUCTURE

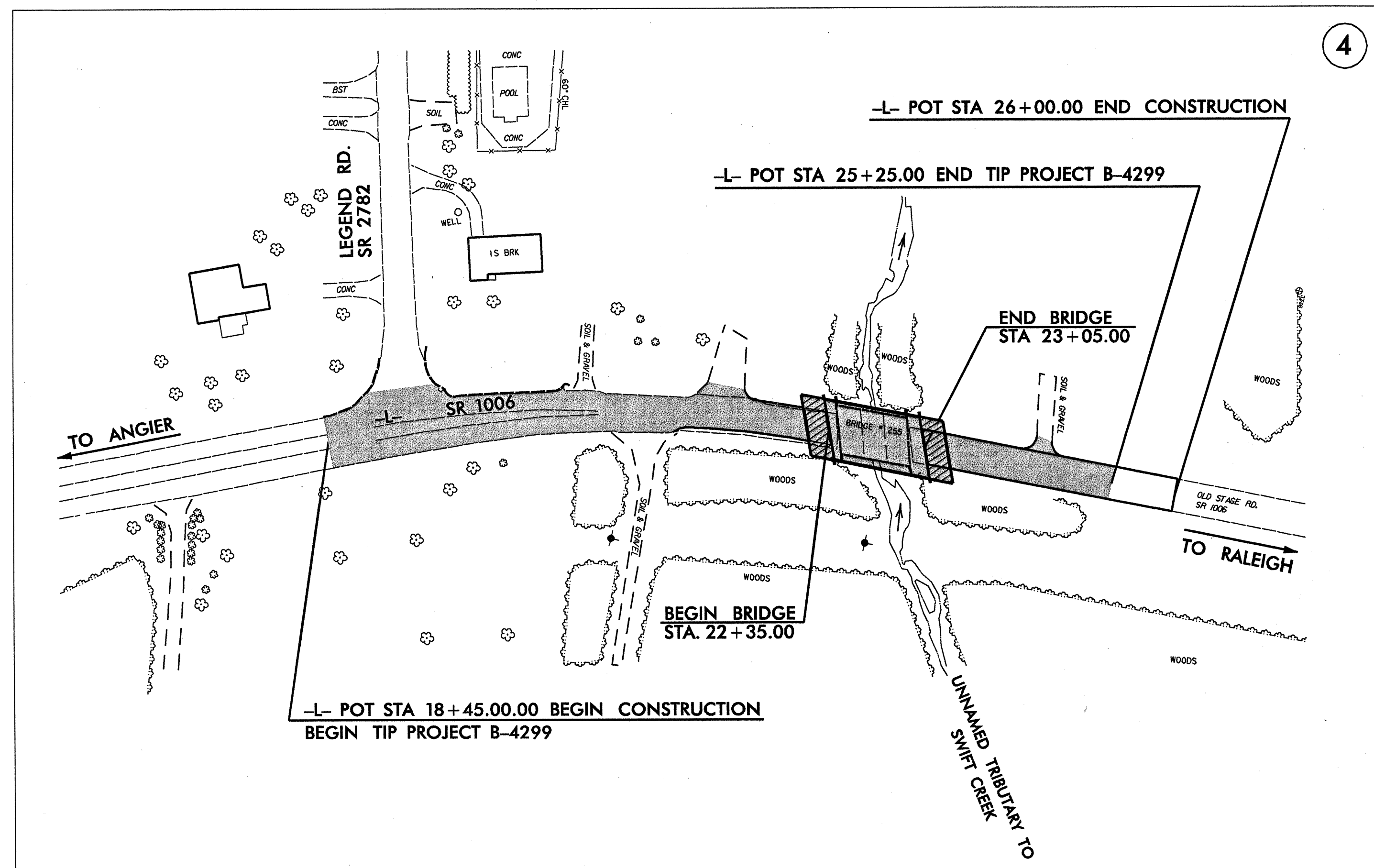

STATE	STATE PROJECT REFERENCE NO.	SHEET NO.	TOTAL SHEETS
N.C.	B-4299	1	
STATE PROJ. NO.	F.A. PROJ. NO.	DESCRIPTION	
33636.1.1	BRSTP-1006(14)	P.E.	
33636.2.1	BRSTP-1006(14)	R/W & UTIL.	
33636.3.1	BRSTP-1006(14)	CONST.	

TRAN SITE CONSULTING
ENGINEERS, INCORPORATED
1300 Paddock Drive, Suite G-10
Raleigh, N.C. 27609

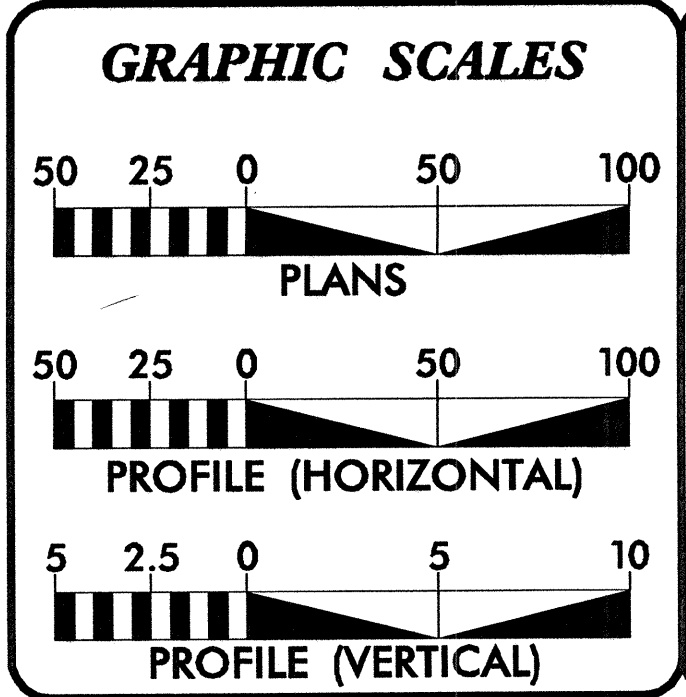

DESIGN DATA

ADT 2007 =	14,270
ADT 2027 =	21,970
DHV =	11 %
D =	63 %
T =	5 % *
V =	40 MPH
* TTST 2 %	DUAL 3 %

PROJECT LENGTH

LENGTH ROADWAY TIP PROJECT B-4299	=	0.116 mi
LENGTH STRUCTURE TIP PROJECT B-4299	=	0.013 mi
TOTAL LENGTH OF TIP PROJECT B-4299	=	0.129 mi

Plans prepared in the office of:

RAMEY KEMP & ASSOCIATES, INC.
TRANSPORTATION ENGINEERS
3800 Forrester Place
Raleigh, North Carolina 27609
919-872-5115 fax 919-878-5418 fax - www.rkempa.com

for the North Carolina Department of Transportation

2006 STANDARD SPECIFICATIONS

RIGHT OF WAY DATE:
FEBRUARY 18, 2005

LETTING DATE:
MAY 15, 2007

N.C.D.O.T. CONTACT:
MALCOLM WATSON, P.E.
PROJECT DESIGN ENGINEER
ROADWAY DESIGN

HYDRAULICS ENGINEER

RICHARD LEON BOLLINGER, JR. P.E.

ROADWAY DESIGN ENGINEER

MATTHEW B. COPPLE P.E.

**DIVISION OF HIGHWAYS
STATE OF NORTH CAROLINA**

ant m. millan
P.E.

STATE DESIGN ENGINEER

**DEPARTMENT OF TRANSPORTATION
FEDERAL HIGHWAY ADMINISTRATION**

APPROVED
DIVISION ADMINISTRATOR

DATE

ROADWAY ENGLISH STANDARD DRAWINGS

The following Roadway Standards as appear in "Roadway Standard Drawings" Highway Design Branch - N. C. Department of Transportation - Raleigh, N. C., Dated July 18, 2006 are applicable to this project and by reference hereby are considered a part of these plans:

STD.NO. TITLE

DIVISION 2 - EARTHWORK

- 200.02 Method of Clearing - Method II
- 225.02 Guide for Grading Subgrade - Secondary and Local
- 225.04 Method of Obtaining Superelevation - Two Lane Pavement

DIVISION 3 - PIPE CULVERTS

- 300.01 Method of Pipe Installation - Method 'A'

DIVISION 4 - MAJOR STRUCTURES

- 422.10 Reinforced Bridge Approach Fills

DIVISION 5 - SUBGRADE, BASES AND SHOULDERS

- 560.01 Method of Shoulder Construction - High Side of Superelevated Curve - Method I

DIVISION 6 - ASPHALT BASES AND PAVEMENTS

- 654.01 Pavement Repairs

DIVISION 8 - INCIDENTALS

- 806.01 Concrete Right-of-Way Marker
- 806.02 Granite Right-of-Way Marker
- 815.03 Pipe Underdrain and Blind Drain
- 816.04 Markers for Drainage Structure and Concrete Pad
- 840.00 Concrete Base Pad for Drainage Structures
- 840.18 Concrete Grated Drop Inlet Type 'B' - 12" thru 36" Pipe
- 840.24 Frames and Narrow Slot Sag Grates
- 840.27 Brick Grated Drop Inlet Type 'B' - 12" thru 36" Pipe
- 840.29 Frames and Narrow Slot Flat Grates
- 840.35 Traffic Bearing Grated Drop Inlet - for Cast Iron Double Frame and Grates
- 840.45 Precast Drainage Structure
- 840.46 Traffic Bearing Precast Drainage Structure
- 840.66 Drainage Structure Steps
- 846.01 Concrete Curb, Gutter and Curb & Gutter
- 846.02 Drop Inlet Installation in Expressway Gutter
- 848.04 Street Turnout
- 862.01 Guardrail Placement
- 862.02 Guardrail Installation
- 862.03 Structure Anchor Units
- 862.04 Anchoring End of Guardrail B-77 and B-83 Anchor Units
- 876.02 Guide for Rip Rap at Pipe Outlets

INDEX OF SHEETS

<u>SHEET NUMBER</u>	<u>SHEET</u>
1	TITLE SHEET
1-A	INDEX OF SHEETS, GENERAL NOTES, AND LIST OF STANDARD DRAWINGS
1-B	CONVENTIONAL SYMBOLS
1-C	SURVEY CONTROL SHEET
2 THRU 2-A	PAVEMENT SCHEDULE, TYPICAL SECTIONS, AND STRUCTURE DETAIL
2-B	DETAIL OF PREFORMED SCOUR HOLE
2-C	DETAIL OF 2GI / TBJB
2-D	DETAIL OF ANCHORAGE FOR FRAMES
3	SUMMARY OF QUANTITIES
3-A	SUMMARY OF DRAINAGE QUANTITIES GUARDRAIL, PAVEMENT REMOVAL, AND EARTHWORK
4	PLAN SHEET
5	DETOUR DETAIL SHEET
6	PROFILE SHEET
TCP-1 THRU TCP-6	TRAFFIC CONTROL PLANS
PM-1 THRU PM-3	PAVEMENT MARKING PLANS
EC-1 THRU EC-7	EROSION CONTROL PLANS
RF-1	REFORESTATION PLANS
SIG-1 THRU SIG-5	SIGNAL PLANS
UO-1 THRU UO-2	UTILITIES BY OTHERS
X-1	CROSS-SECTION SUMMARY
X-2 THRU X-11	CROSS-SECTIONS
S-1 THRU S-19	STRUCTURE PLANS

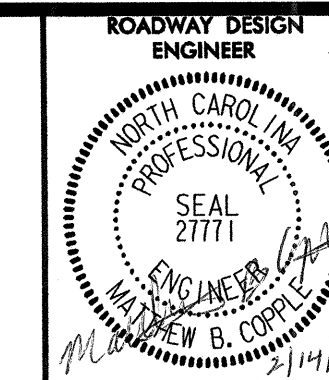

GENERAL NOTES: 2006 SPECIFICATIONS
EFFECTIVE: 7-18-06

GRADING AND SURFACING OR RESURFACING AND WIDENING:

THE GRADE LINES SHOWN DENOTE THE FINISHED ELEVATION OF THE PROPOSED SURFACING AT GRADE POINTS SHOWN ON THE TYPICAL SECTIONS. WHERE NO GRADE LINES ARE SHOWN, THE PROFILES SHOWN DENOTE THE TOP ELEVATION OF THE EXISTING PAVEMENT ALONG THE CENTER LINE OF SURVEY ON WHICH THE PROPOSED RESURFACING WILL BE PLACED. GRADE LINES MAY BE ADJUSTED BY THE ENGINEER IN ORDER TO SECURE A PROPER TIE-IN.

CLEARING:

CLEARING ON THIS PROJECT SHALL BE PERFORMED TO THE LIMITS ESTABLISHED BY METHOD II.

SUPERELEVATION:

ALL CURVES ON THIS PROJECT SHALL BE SUPERELEVATED IN ACCORDANCE WITH STD. NO. 225.04 USING THE RATE OF SUPERELEVATION AND RUNOFF SHOWN ON THE PLANS. SUPERELEVATION IS TO BE REVOLVED ABOUT THE GRADE POINTS SHOWN ON THE TYPICAL SECTIONS.

SHOULDER CONSTRUCTION:

ASPHALT, EARTH, AND CONCRETE SHOULDER CONSTRUCTION ON THE HIGH SIDE OF SUPERELEVATED CURVES SHALL BE IN ACCORDANCE WITH STD. NO. 560.01.

SIDE ROADS:

THE CONTRACTOR WILL BE REQUIRED TO DO ALL NECESSARY WORK TO PROVIDE SUITABLE CONNECTIONS WITH ALL ROADS, STREETS AND DRIVES ENTERING THIS PROJECT. THIS WORK WILL BE PAID FOR AT THE CONTRACT UNIT PRICE FOR THE PARTICULAR ITEMS INVOLVED.

UNDERDRAINS:

UNDERDRAINS SHALL BE CONSTRUCTED IN ACCORDANCE WITH STD. NO. 815.03 AT LOCATIONS DIRECTED BY THE ENGINEER.

GUARDRAIL:

THE GUARDRAIL LOCATIONS SHOWN ON THE PLANS MAY BE ADJUSTED DURING CONSTRUCTION AS DIRECTED BY THE ENGINEER. THE CONTRACTOR SHOULD CONSULT WITH THE ENGINEER PRIOR TO ORDERING GUARDRAIL MATERIAL.

TEMPORARY SHORING:

SHORING REQUIRED FOR THE MAINTENANCE OF TRAFFIC WILL BE PAID FOR AS "EXTRA WORK" IN ACCORDANCE WITH SECTION 104-7.

SUBSURFACE PLANS:

NO SUBSURFACE PLANS ARE AVAILABLE ON THIS PROJECT. THE CONTRACTOR SHOULD MAKE HIS OWN INVESTIGATION AS TO THE SUBSURFACE CONDITIONS.

END BENTS:

THE ENGINEER SHALL CHECK THE STRUCTURE END BENT PLANS, DETAILS, AND CROSS-SECTION PRIOR TO SETTING OF THE SLOPE STAKES FOR THE EMBANKMENT OR EXCAVATION APPROACHING A BRIDGE.

UTILITIES:

UTILITY OWNERS ON THIS PROJECT ARE: PROGRESS ENERGY, ANY RELOCATION OF EXISTING UTILITIES WILL BE ACCOMPLISHED BY OTHERS.

RIGHT-OF-WAY MARKERS:

ALL RIGHT-OF-WAY MARKERS ON THIS PROJECT SHALL BE PLACED BY CONTRACT.









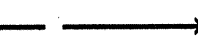

STATE OF NORTH CAROLINA
DIVISION OF HIGHWAYS

CONVENTIONAL PLAN SHEET SYMBOLS



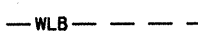





Note: Not to Scale

*S.U.E. = Subsurface Utility Engineering



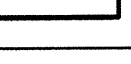
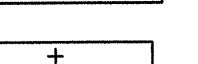

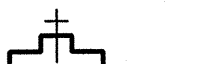



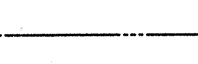

BOUNDARIES AND PROPERTY:

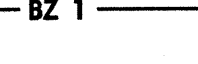
- State Line _____
- County Line _____
- Township Line _____
- City Line _____
- Reservation Line _____
- Property Line _____
- Existing Iron Pin _____ 
- Property Corner _____ 
- Property Monument _____ 
- Parcel/Sequence Number _____ 
- Existing Fence Line _____ 
- Proposed Woven Wire Fence _____ 
- Proposed Chain Link Fence _____ 
- Proposed Barbed Wire Fence _____ 
- Existing Wetland Boundary _____ 
- Proposed Wetland Boundary _____ 
- Existing Endangered Animal Boundary _____ 
- Existing Endangered Plant Boundary _____ 



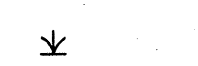

BUILDINGS AND OTHER CULTURE:

- Gas Pump Vent or U/G Tank Cap _____ 
- Sign _____ 
- Well _____ 
- Small Mine _____ 
- Foundation _____ 
- Area Outline _____ 
- Cemetery _____ 
- Building _____ 
- School _____ 
- Church _____ 
- Dam _____ 





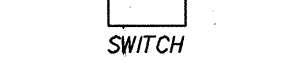

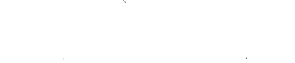

HYDROLOGY:

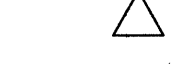
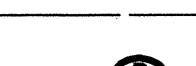
- Stream or Body of Water _____ 
- Hydro, Pool or Reservoir _____ 
- Jurisdictional Stream _____ 
- Buffer Zone 1 _____ 
- Buffer Zone 2 _____ 
- Flow Arrow _____ 
- Disappearing Stream _____ 
- Spring _____ 
- Swamp Marsh _____ 
- Proposed Lateral, Tail, Head Ditch _____ 
- False Sump _____ 







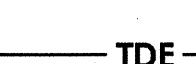
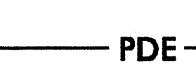
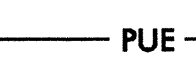

RAILROADS:

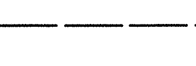
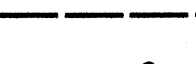
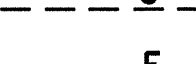
- Standard Gauge _____ 
- RR Signal Milepost _____ 
- Switch _____ 
- RR Abandoned _____ 
- RR Dismantled _____ 



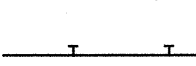
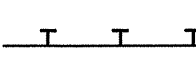
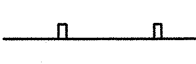
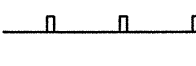

RIGHT OF WAY:

- Baseline Control Point _____ 
- Existing Right of Way Marker _____ 
- Existing Right of Way Line _____ 
- Proposed Right of Way Line _____ 
- Proposed Right of Way Line with Iron Pin and Cap Marker _____ 
- Proposed Right of Way Line with Concrete or Granite Marker _____ 
- Existing Control of Access _____ 
- Proposed Control of Access _____ 
- Existing Easement Line _____ 
- Proposed Temporary Construction Easement _____ 
- Proposed Temporary Drainage Easement _____ 
- Proposed Permanent Drainage Easement _____ 
- Proposed Permanent Utility Easement _____ 



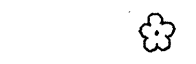

ROADS AND RELATED FEATURES:

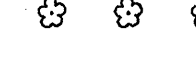
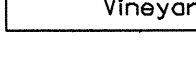
- Existing Edge of Pavement _____ 
- Existing Curb _____ 
- Proposed Slope Stakes Cut _____ 
- Proposed Slope Stakes Fill _____ 
- Proposed Wheel Chair Ramp _____ 
- Proposed Wheel Chair Ramp Curb Cut _____ 
- Curb Cut for Future Wheel Chair Ramp _____ 
- Existing Metal Guardrail _____ 
- Proposed Guardrail _____ 
- Existing Cable Guiderail _____ 
- Proposed Cable Guiderail _____ 
- Equality Symbol _____ 
- Pavement Removal _____ 



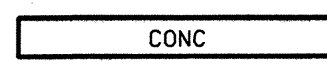
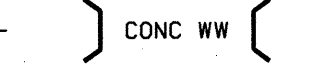
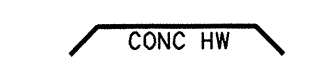
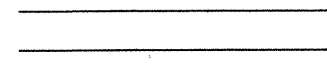

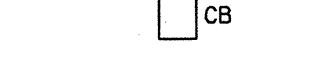
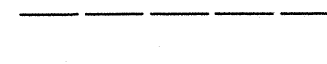
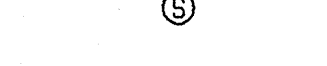





VEGETATION:

- Single Tree _____ 
- Single Shrub _____ 
- Hedge _____ 
- Woods Line _____ 
- Orchard _____ 
- Vineyard _____ 













EXISTING STRUCTURES:

- MAJOR:**
- Bridge, Tunnel or Box Culvert _____ 
 - Bridge Wing Wall, Head Wall and End Wall _____ 
- MINOR:**
- Head and End Wall _____ 
 - Pipe Culvert _____ 
 - Footbridge _____ 
 - Drainage Box: Catch Basin, DI or JB _____ 
 - Paved Ditch Gutter _____ 
 - Storm Sewer Manhole _____ 
 - Storm Sewer _____ 







UTILITIES:

- POWER:**
- Existing Power Pole _____ 
 - Proposed Power Pole _____ 
 - Existing Joint Use Pole _____ 
 - Proposed Joint Use Pole _____ 
 - Power Manhole _____ 
 - Power Line Tower _____ 
 - Power Transformer _____ 
 - U/G Power Cable Hand Hole _____ 
 - H-Frame Pole _____ 
 - Recorded U/G Power Line _____ 
 - Designated U/G Power Line (S.U.E.*) _____ 









TELEPHONE:

- Existing Telephone Pole _____ 
- Proposed Telephone Pole _____ 
- Telephone Manhole _____ 
- Telephone Booth _____ 
- Telephone Pedestal _____ 
- Telephone Cell Tower _____ 
- U/G Telephone Cable Hand Hole _____ 
- Recorded U/G Telephone Cable _____ 
- Designated U/G Telephone Cable (S.U.E.*) _____ 
- Recorded U/G Telephone Conduit _____ 
- Designated U/G Telephone Conduit (S.U.E.*) _____ 
- Recorded U/G Fiber Optics Cable _____ 
- Designated U/G Fiber Optics Cable (S.U.E.*) _____ 





WATER:

- Water Manhole _____ 
- Water Meter _____ 
- Water Valve _____ 
- Water Hydrant _____ 
- Recorded U/G Water Line _____ 
- Designated U/G Water Line (S.U.E.*) _____ 
- Above Ground Water Line _____ 







TV:

- TV Satellite Dish _____ 
- TV Pedestal _____ 
- TV Tower _____ 
- U/G TV Cable Hand Hole _____ 
- Recorded U/G TV Cable _____ 
- Designated U/G TV Cable (S.U.E.*) _____ 
- Recorded U/G Fiber Optic Cable _____ 
- Designated U/G Fiber Optic Cable (S.U.E.*) _____ 











GAS:

- Gas Valve _____ 
- Gas Meter _____ 
- Recorded U/G Gas Line _____ 
- Designated U/G Gas Line (S.U.E.*) _____ 
- Above Ground Gas Line _____ 

SANITARY SEWER:

- Sanitary Sewer Manhole _____ 
- Sanitary Sewer Cleanout _____ 
- U/G Sanitary Sewer Line _____ 
- Above Ground Sanitary Sewer _____ 
- Recorded SS Forced Main Line _____ 
- Designated SS Forced Main Line (S.U.E.*) _____ 

MISCELLANEOUS:

- Utility Pole _____ 
- Utility Pole with Base _____ 
- Utility Located Object _____ 
- Utility Traffic Signal Box _____ 
- Utility Unknown U/G Line _____ 
- U/G Tank; Water, Gas, Oil _____ 
- A/G Tank; Water, Gas, Oil _____ 
- U/G Test Hole (S.U.E.*) _____ 
- Abandoned According to Utility Records _____ 
- End of Information _____ 

SURVEY CONTROL SHEET B-4299

PROJECT REFERENCE NO.	SHEET NO.
B-4299	1-C
Location and Surveys	

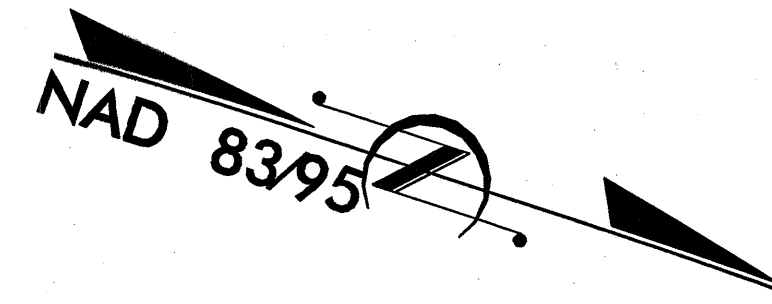

NCDOT STATION B4299-2
 LOCALIZED PROJECT COORDINATES
 N 709498.3809
 E 2102825.8206

NCDOT STATION B4299-1
 LOCALIZED PROJECT COORDINATES
 N 71083.3330
 E 2102669.9510

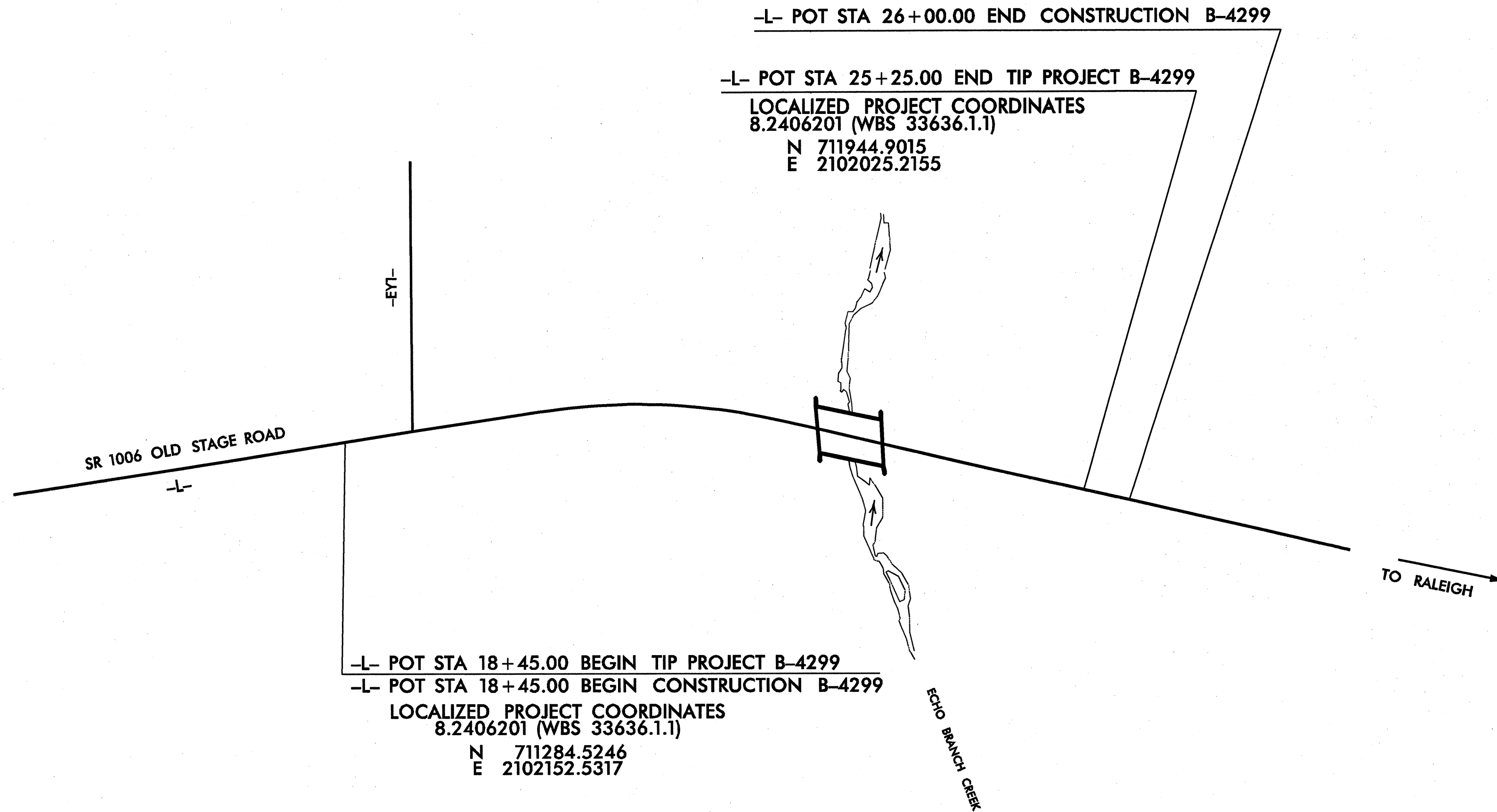

DATUM DESCRIPTION

THE LOCALIZED COORDINATE SYSTEM DEVELOPED FOR THIS PROJECT IS BASED ON THE STATE PLANE COORDINATES ESTABLISHED BY NCDOT FOR MONUMENT "B4299-1" WITH NAD 1983/95 STATE PLANE GRID COORDINATES OF NORTHING: 710183.3330(11) EASTING: 2102669.9510(11) THE AVERAGE COMBINED GRID FACTOR USED ON THIS PROJECT (GROUND TO GRID) IS: 0.99993906 THE N.C. LAMBERT GRID BEARING AND LOCALIZED HORIZONTAL GROUND DISTANCE FROM "B4299-1" TO -L- STATION 18+45.00 IS N 25°10'03.3" W 1216.69' ALL LINEAR DIMENSIONS ARE LOCALIZED HORIZONTAL DISTANCES VERTICAL DATUM USED IS NAVD 88

BL	POINT	DESC.	NORTH	EAST	ELEVATION	L STATION	OFFSET
	101	B-4299 BL-101	710568.4520	2102452.8310	299.35	18+68.97	26.83 LT
	102	B-4299 BL-102	711350.3960	2102152.0460	268.75	19+05.03	27.12 RT
	103	B-4299 BL-103	711650.3210	2102025.5180	266.65	22+30.92	17.13 LT
	104	B-4299 BL-104	712186.4890	2101995.3820	275.70	27+67.93	15.48 LT
	105	B-4299 BL-105	712575.4390	2102010.3250	299.69	31+54.91	24.77 RT

 203 ELEVATION - 264.75
 N 711638 E 2102016
 L STATION 22+19 27' LEFT
 R/R SPIKE IN 42" SWEET GUM

 204 ELEVATION - 289.46
 N 712260 E 2101968
 L STATION 28+43 38' LEFT
 R/R SPIKE IN 14" SWEET GUM

NOTES:

THE CONTROL DATA FOR THIS PROJECT CAN BE FOUND ELECTRONICALLY BY SELECTING PROJECT CONTROL DATA AT:
[HTTP://WWW.NCDOT.ORG/DOH/PRECONSTRUCTION/HIGHWAY/LOCATION/PROJECT/](http://www.ncdot.org/doh/preconstruction/highway/location/project/)
 THE FILES TO BE FOUND ARE AS FOLLOWS
 B4299 LS CONTROL 070118.TXT
 SITE CALIBRATION INFORMATION HAS NOT BEEN PROVIDED FOR THIS PROJECT.
 IF FURTHER INFORMATION IS NEEDED, PLEASE CONTACT THE LOCATION AND SURVEYS UNIT.
 ☉ INDICATES GEODETIC CONTROL MONUMENTS USED OR SET FOR HORIZONTAL PROJECT CONTROL BY THE NCDOT LOCATION AND SURVEYS UNIT.
 PROJECT CONTROL ESTABLISHED USING GLOBAL POSITIONING SYSTEM.

NOTE: DRAWING NOT TO SCALE

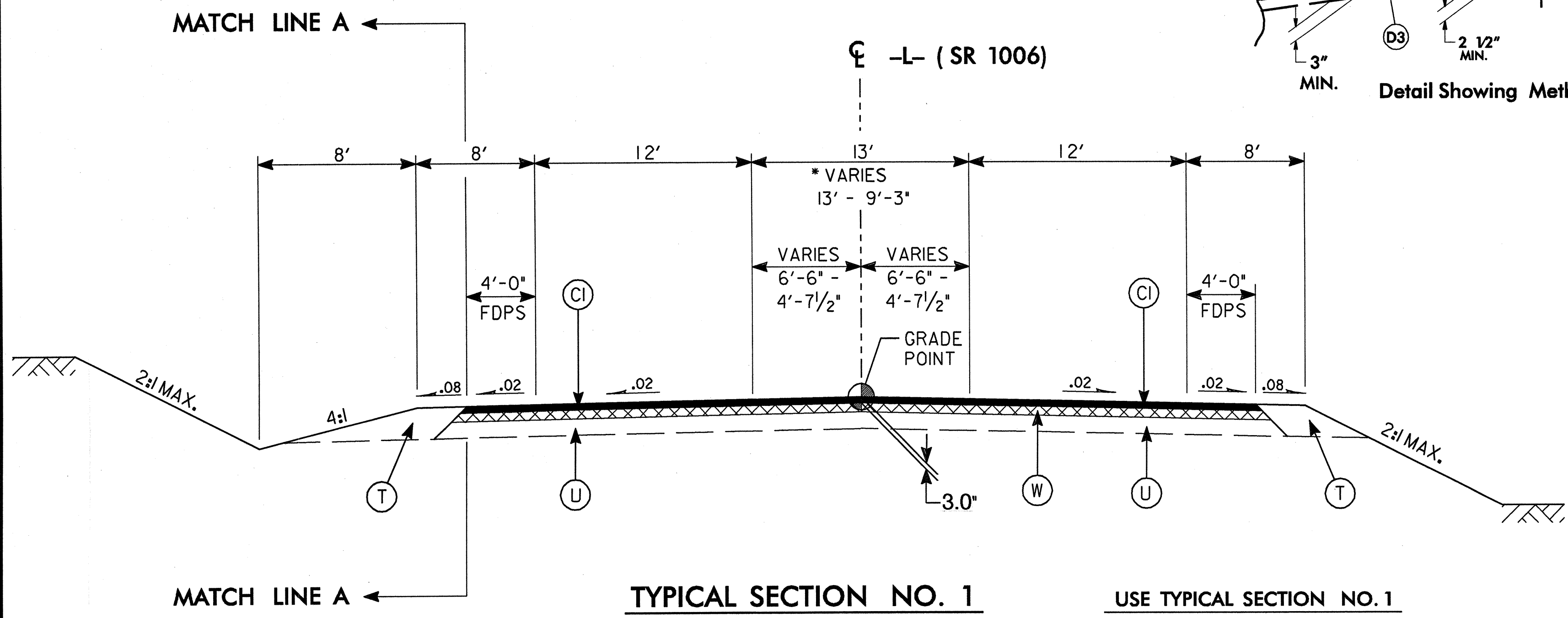
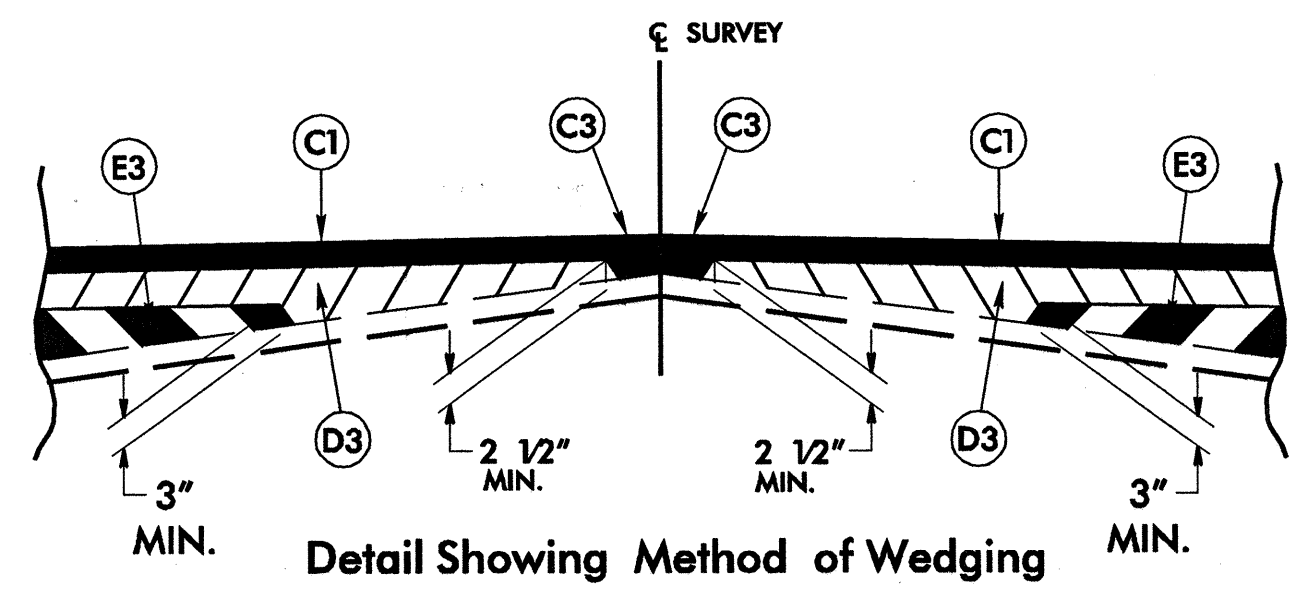

NOTE:
FEATHER TO EXISTING PAVEMENT FROM:
-L- STA. 18+45.00 TO STA. 18+70.00
-L- STA. 25+00.00 TO STA. 25+25.00

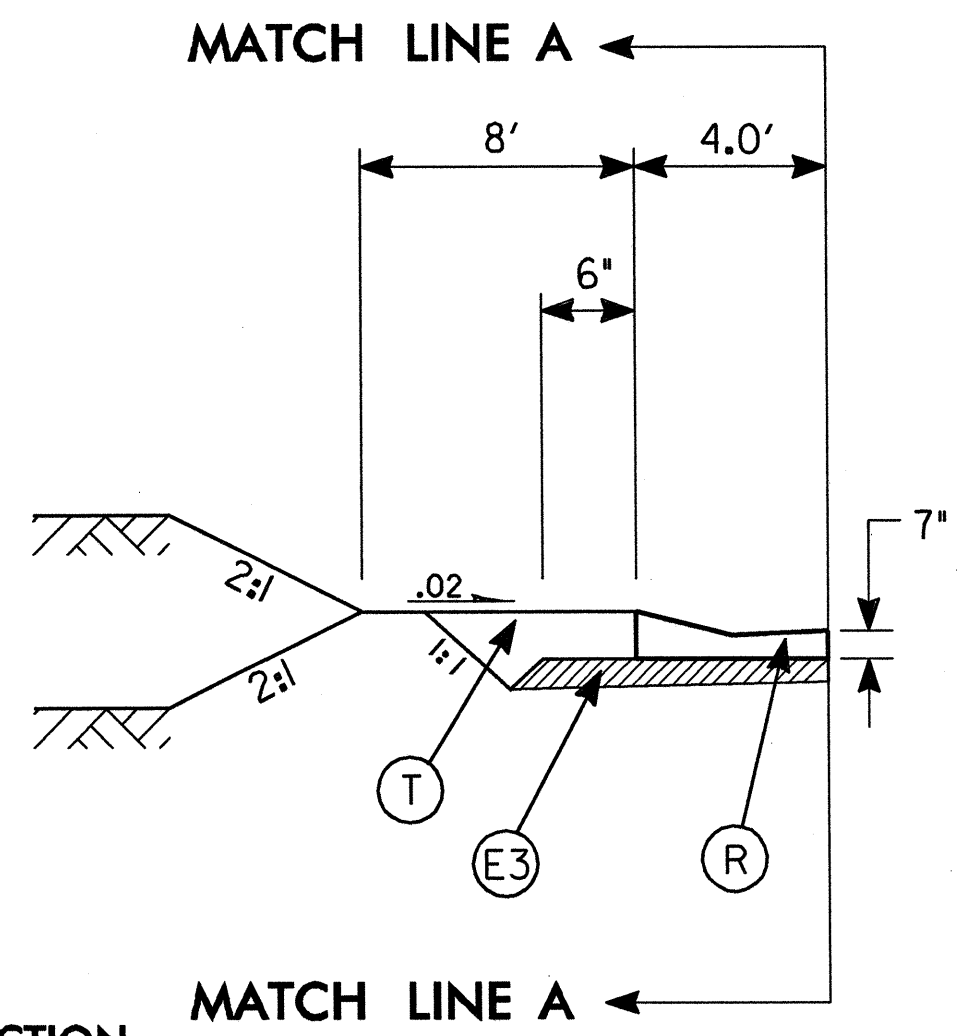
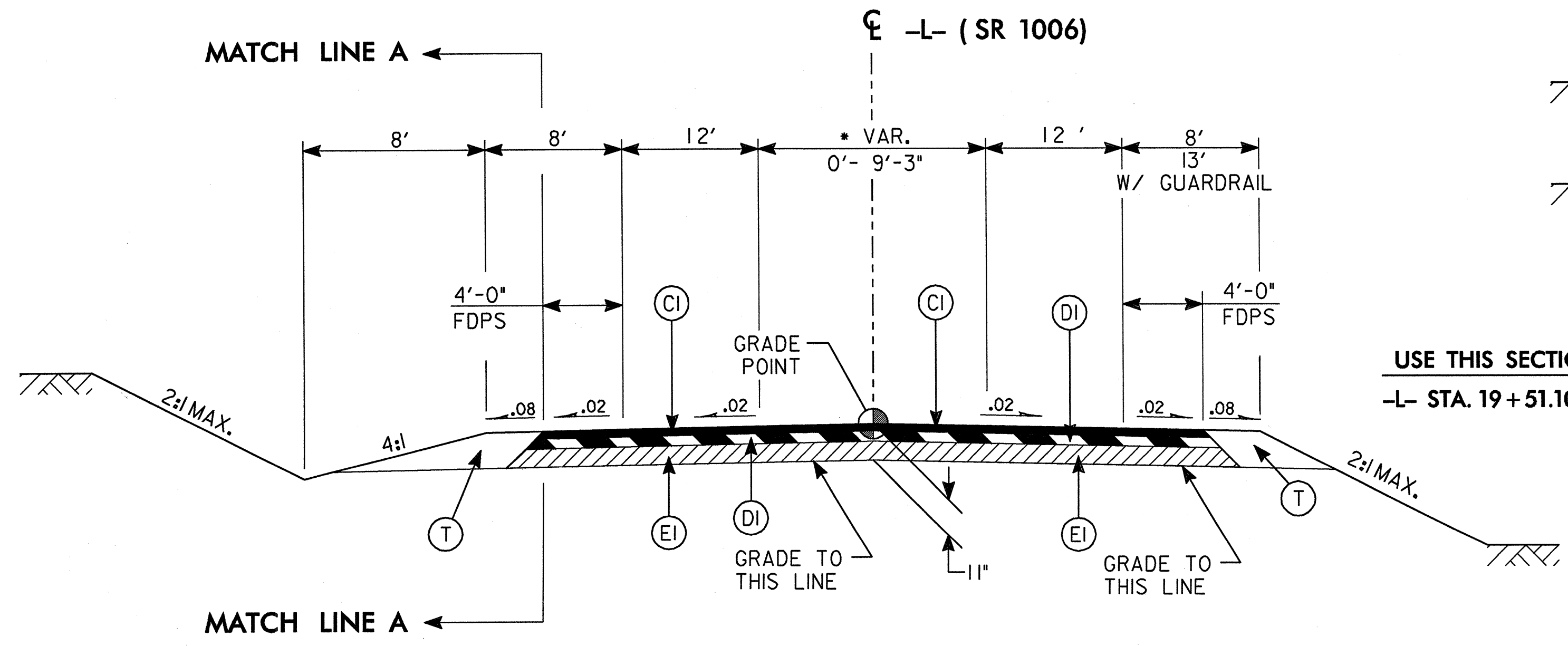

PAVEMENT SCHEDULE	
A1	PROP. APPROX. 6" PORTLAND CEMENT CONCRETE PAVEMENT
C	PROP. APPROX. 1 1/2" ASPHALT CONCRETE SURFACE COURSE, TYPE S9.5C, AT AN AVERAGE RATE OF 168 LBS. PER SQ. YD.
C1	PROP. APPROX. 3" ASPHALT CONCRETE SURFACE COURSE, TYPE S9.5B, AT AN AVERAGE RATE OF 168 LBS. PER SQ. YD. IN EACH OF TWO LAYERS.
C2	PROP. APPROX. 3" ASPHALT CONCRETE SURFACE COURSE, TYPE S9.5C, AT AN AVERAGE RATE OF 168 LBS. PER SQ. YD. IN EACH OF TWO LAYERS.
C3	PROP. VAR. DEPTH ASPHALT CONCRETE SURFACE COURSE, TYPE S9.5B, AT AN AVERAGE RATE OF 112 LBS. PER SQ. YD. PER 1" DEPTH TO BE PLACED IN LAYERS NOT TO EXCEED 2" IN DEPTH.
D1	PROP. APPROX. 3" ASPHALT CONCRETE INTERMEDIATE COURSE, TYPE I19.0B, AT AN AVERAGE RATE OF 342 LBS. PER SQ. YD.
D2	PROP. APPROX. 4" ASPHALT CONCRETE INTERMEDIATE COURSE, TYPE I19.0C, AT AN AVERAGE RATE OF 456 LBS. PER SQ. YD.
D3	PROP. VAR. DEPTH ASPHALT CONCRETE INTERMEDIATE COURSE, TYPE I19.0B, AT AN AVERAGE RATE OF 114 LBS. PER SQ. YD. PER 1" DEPTH TO BE PLACED IN LAYERS NOT LESS THAN 2 1/2" IN DEPTH OR GREATER THAN 4" IN DEPTH.
E1	PROP. APPROX. 5" ASPHALT CONCRETE BASE COURSE, TYPE B25.0B, AT AN AVERAGE RATE OF 570 LBS. PER SQ. YD.
E2	PROP. APPROX. 7 1/2" ASPHALT CONCRETE BASE COURSE, TYPE B25.0C, AT AN AVERAGE RATE OF 428 LBS. PER SQ. YD. IN EACH OF TWO LAYERS.
E3	PROP. VAR. DEPTH ASPHALT CONCRETE BASE COURSE, TYPE B25.0B, AT AN AVERAGE RATE OF 114 LBS. PER SQ. YD. PER 1" DEPTH TO BE PLACED IN LAYERS NOT LESS THAN 3" IN DEPTH OR GREATER THAN 5 1/2" IN DEPTH.
R	48" EXPRESSWAY GUTTER
T	EARTH MATERIAL.
U	EXISTING PAVEMENT.

NOTE: PAVEMENT EDGE SLOPES ARE 1:1 UNLESS SHOWN OTHERWISE.

USE TYPICAL SECTION NO. 2
* -L- STA. 20+00.00 TO STA. 21+94.29
-L- STA. 21+94.29 TO 22+35.00 (BEGIN BRIDGE)
-L- STA. 23+05.00 (END BRIDGE) TO STA. 24+50.00
-L- STA. 24+50.00 TO STA. 25+00.00 (OVERLAY ONLY)

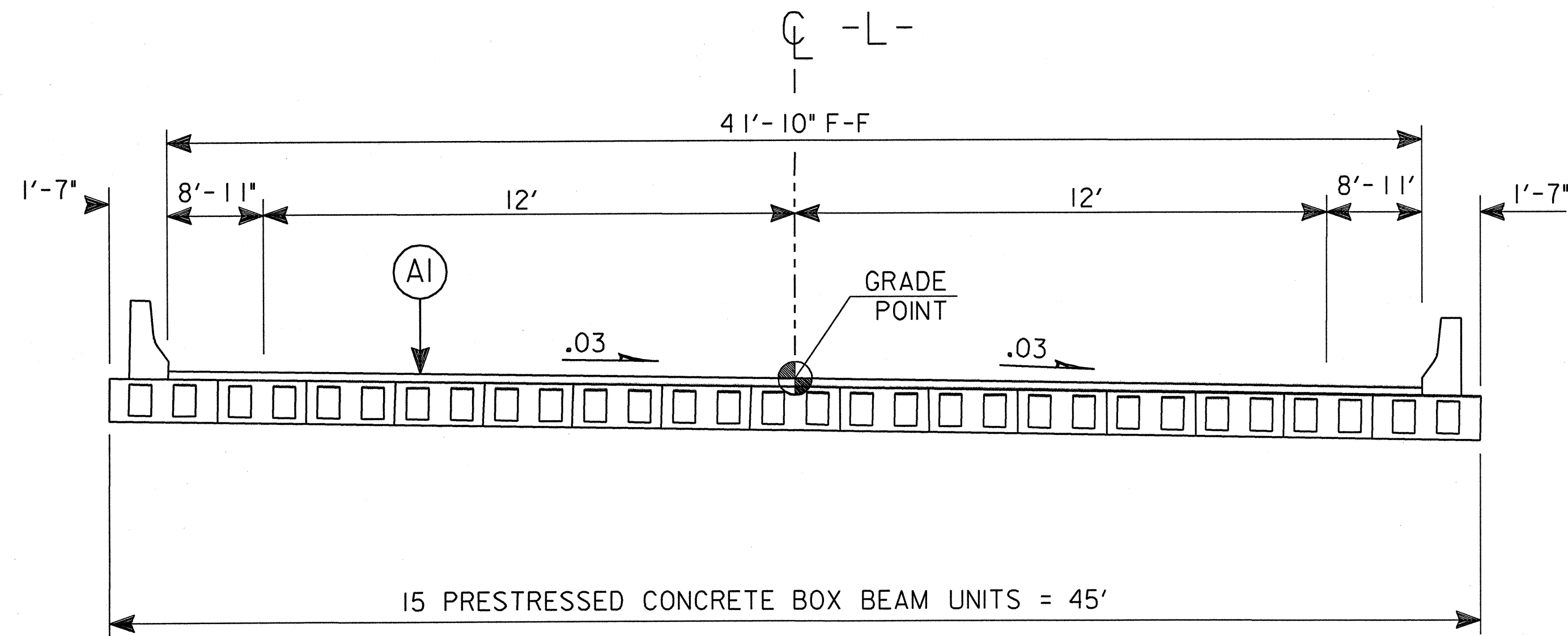

STRUCTURE DETAIL

PAVEMENT SCHEDULE	
A1	PROP. APPROX. 6" PORTLAND CEMENT CONCRETE PAVEMENT
C	PROP. APPROX. 1 1/2" ASPHALT CONCRETE SURFACE COURSE, TYPE S9.5C, AT AN AVERAGE RATE OF 168 LBS. PER SQ. YD.
C1	PROP. APPROX. 3" ASPHALT CONCRETE SURFACE COURSE, TYPE S9.5B, AT AN AVERAGE RATE OF 168 LBS. PER SQ. YD. IN EACH OF TWO LAYERS.
C2	PROP. APPROX. 3" ASPHALT CONCRETE SURFACE COURSE, TYPE S9.5C, AT AN AVERAGE RATE OF 168 LBS. PER SQ. YD. IN EACH OF TWO LAYERS.
C3	PROP. VAR. DEPTH ASPHALT CONCRETE SURFACE COURSE, TYPE S9.5B, AT AN AVERAGE RATE OF 112 LBS. PER SQ. YD. PER 1" DEPTH TO BE PLACED IN LAYERS NOT TO EXCEED 2" IN DEPTH.
D1	PROP. APPROX. 3" ASPHALT CONCRETE INTERMEDIATE COURSE, TYPE I19.0B, AT AN AVERAGE RATE OF 342 LBS. PER SQ. YD.
D2	PROP. APPROX. 4" ASPHALT CONCRETE INTERMEDIATE COURSE, TYPE I19.0C, AT AN AVERAGE RATE OF 456 LBS. PER SQ. YD.
D3	PROP. VAR. DEPTH ASPHALT CONCRETE INTERMEDIATE COURSE, TYPE I19.0B, AT AN AVERAGE RATE OF 114 LBS. PER SQ. YD. PER 1" DEPTH TO BE PLACED IN LAYERS NOT LESS THAN 2 1/2" IN DEPTH OR GREATER THAN 4" IN DEPTH.
E1	PROP. APPROX. 5" ASPHALT CONCRETE BASE COURSE, TYPE B25.0B, AT AN AVERAGE RATE OF 570 LBS. PER SQ. YD.
E2	PROP. APPROX. 7 1/2" ASPHALT CONCRETE BASE COURSE, TYPE B25.0C, AT AN AVERAGE RATE OF 428 LBS. PER SQ. YD. IN EACH OF TWO LAYERS.
E3	PROP. VAR. DEPTH ASPHALT CONCRETE BASE COURSE, TYPE B25.0B, AT AN AVERAGE RATE OF 114 LBS. PER SQ. YD. PER 1" DEPTH TO BE PLACED IN LAYERS NOT LESS THAN 3" IN DEPTH OR GREATER THAN 5 1/2" IN DEPTH.
R	48" EXPRESSWAY GUTTER
T	EARTH MATERIAL.
U	EXISTING PAVEMENT.

NOTE: PAVEMENT EDGE SLOPES ARE 1:1 UNLESS SHOWN OTHERWISE.

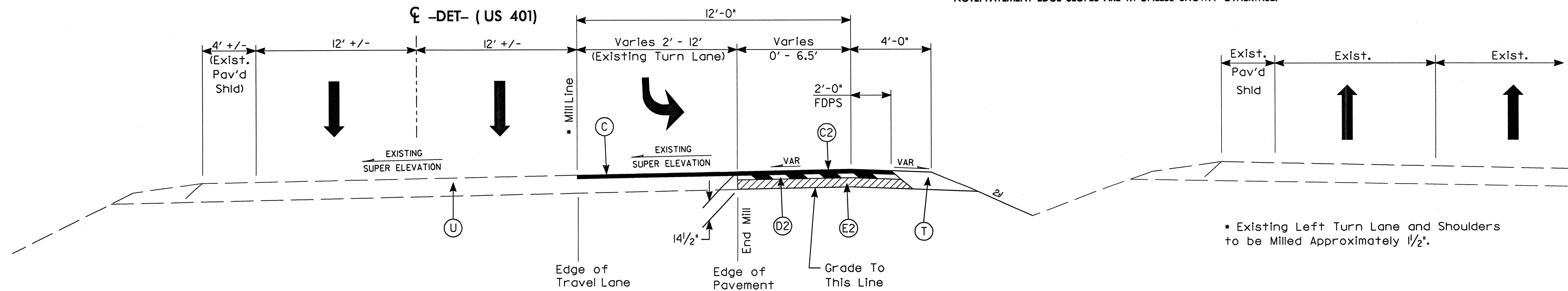

TYPICAL SECTION NO. 3

USE TYPICAL SECTION NO. 3

-DET- STA. 11+72.00 TO STA. 17+02.00

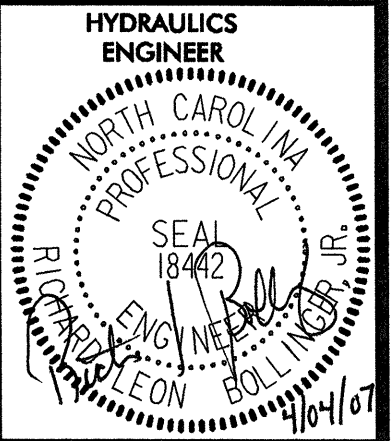

PREFORMED SCOUR HOLE DETAIL

PLAN VIEW

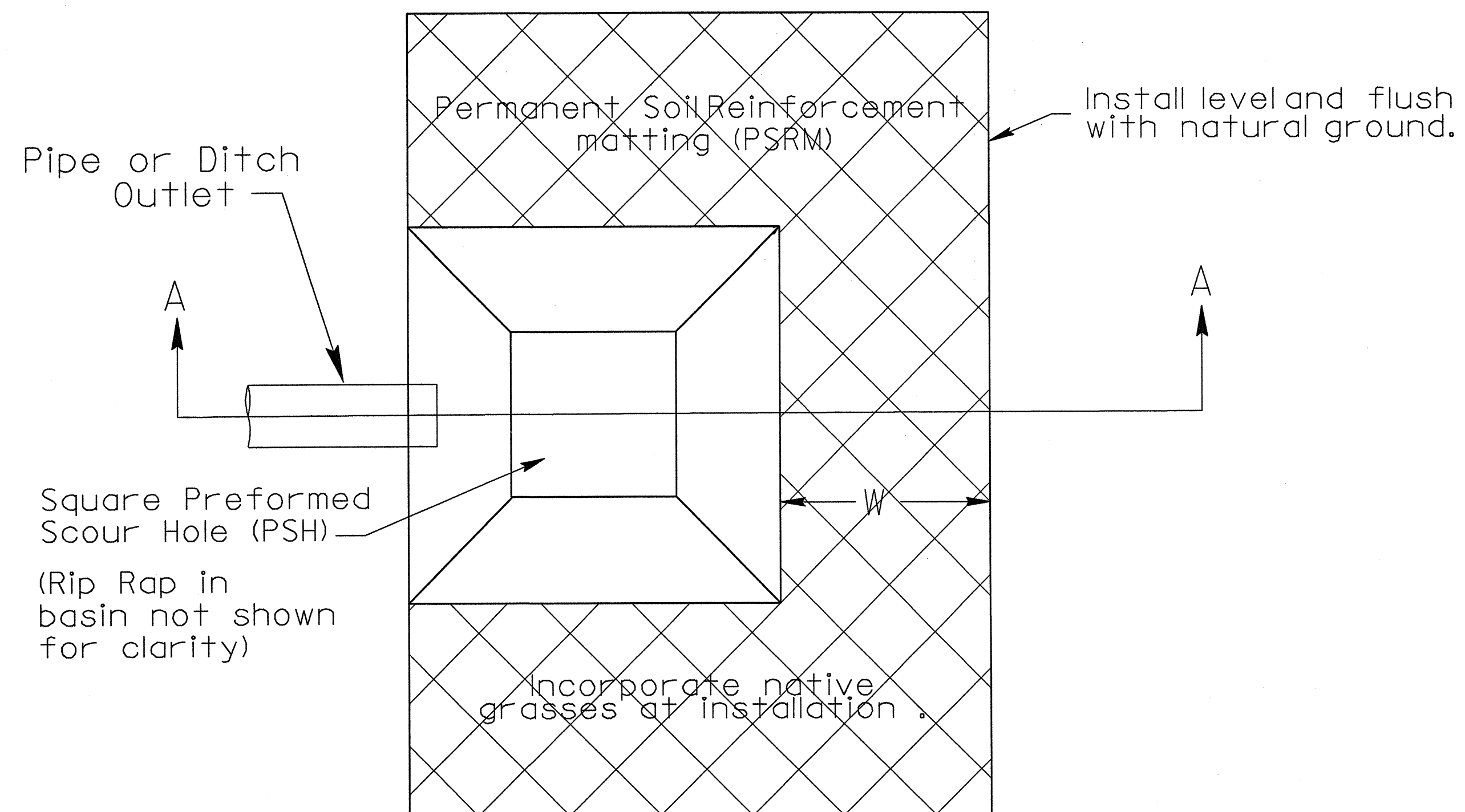

LOCATION (AT OUTLET)
Sta 23+42 -L- (Lt)
Sta 23+75 -L- (Rt)

B	5.0	ft
D	2.0	ft
W	5.0	ft
d	0.5	ft

SECTION A-A

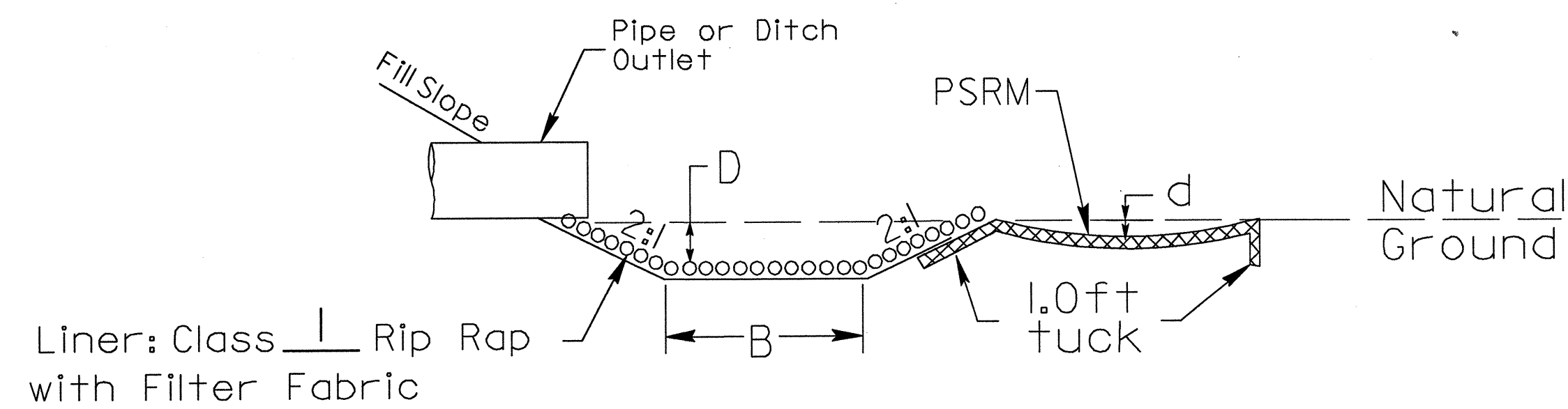

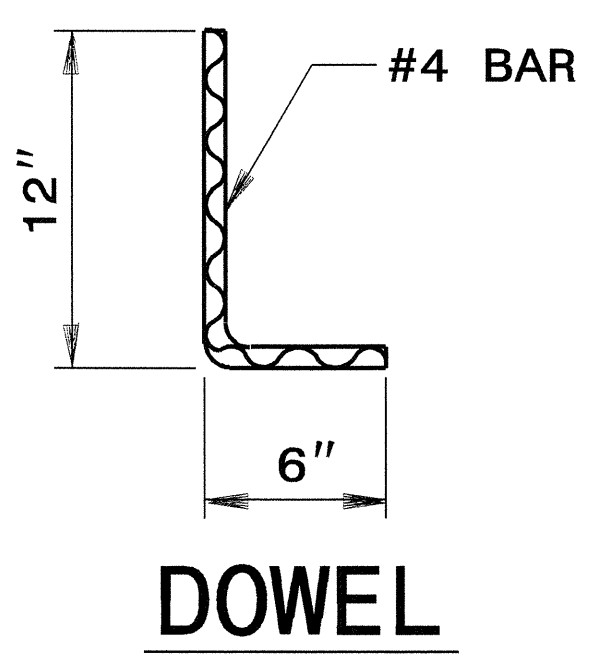
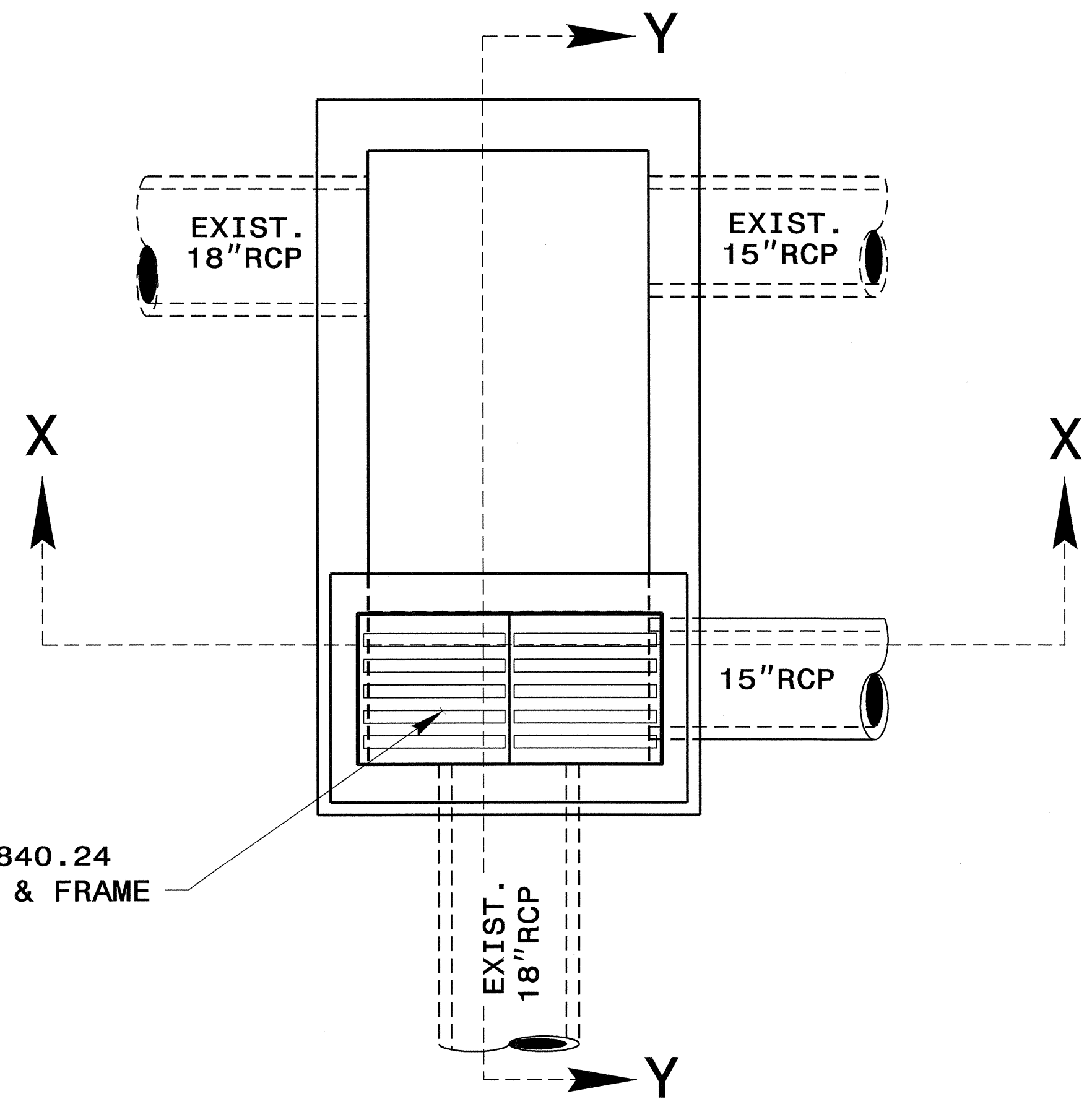

GENERAL NOTES:
 USE CLASS "B" CONCRETE THROUGHOUT.
 PROVIDE ALL DROP INLETS OVER 3'-6" IN DEPTH WITH STEPS 12" ON CENTER. USE STEPS WHICH COMPLY WITH STD. DRAWING 840.66.
 ** OPTIONAL CONSTRUCTION - MONOLITHIC POUR 2" KEYWAY OR #4 BAR DOWELS AT 12" CENTERS AS DIRECTED BY THE ENGINEER.
 USE FORMS FOR THE CONSTRUCTION OF THE BOTTOM SLAB.
 IF REINFORCED CONCRETE PIPE IS SET IN BOTTOM SLAB OF BOX, ADD TO SLAB AS SHOWN ON STD. NO. 840.00.
 USE STD NO. 840.24 FOR GRATE AND FRAME UNLESS OTHERWISE INDICATED.
 CONSTRUCT WITH PIPE CROWNS MATCHING.
 CHAMFER ALL EXPOSED CORNERS 1".
 2" MINIMUM CLEARANCE ON ALL REINFORCING STEEL.
 ADJUST REINFORCING STEEL AND DIMENSIONS AS DIRECTED BY THE ENGINEER.

BILL OF MATERIALS				
BAR	NO.	SIZE	LENGTH	WEIGHT
H	15	#6	4'-4"	98
H1	9	#6	6'-4"	86
H2	29	#5	4'-4"	132
H3	19	#5	9'-0"	179
V	52	#5	2'-10"	154
** DOWEL	28	#4	1'-6"	29
TOTAL REINF. STEEL (lbs)				678
CONC. (cu. yds)				4.5
DEDUCTIONS FOR PIPES				
2-15" RCP (cu.yds.)				-0.1
2-18" RCP (cu.yds.)				-0.1
INLET OPENING (cu.yds.)				-0.2
TOTAL CONC. (cu.yds.)				4.1

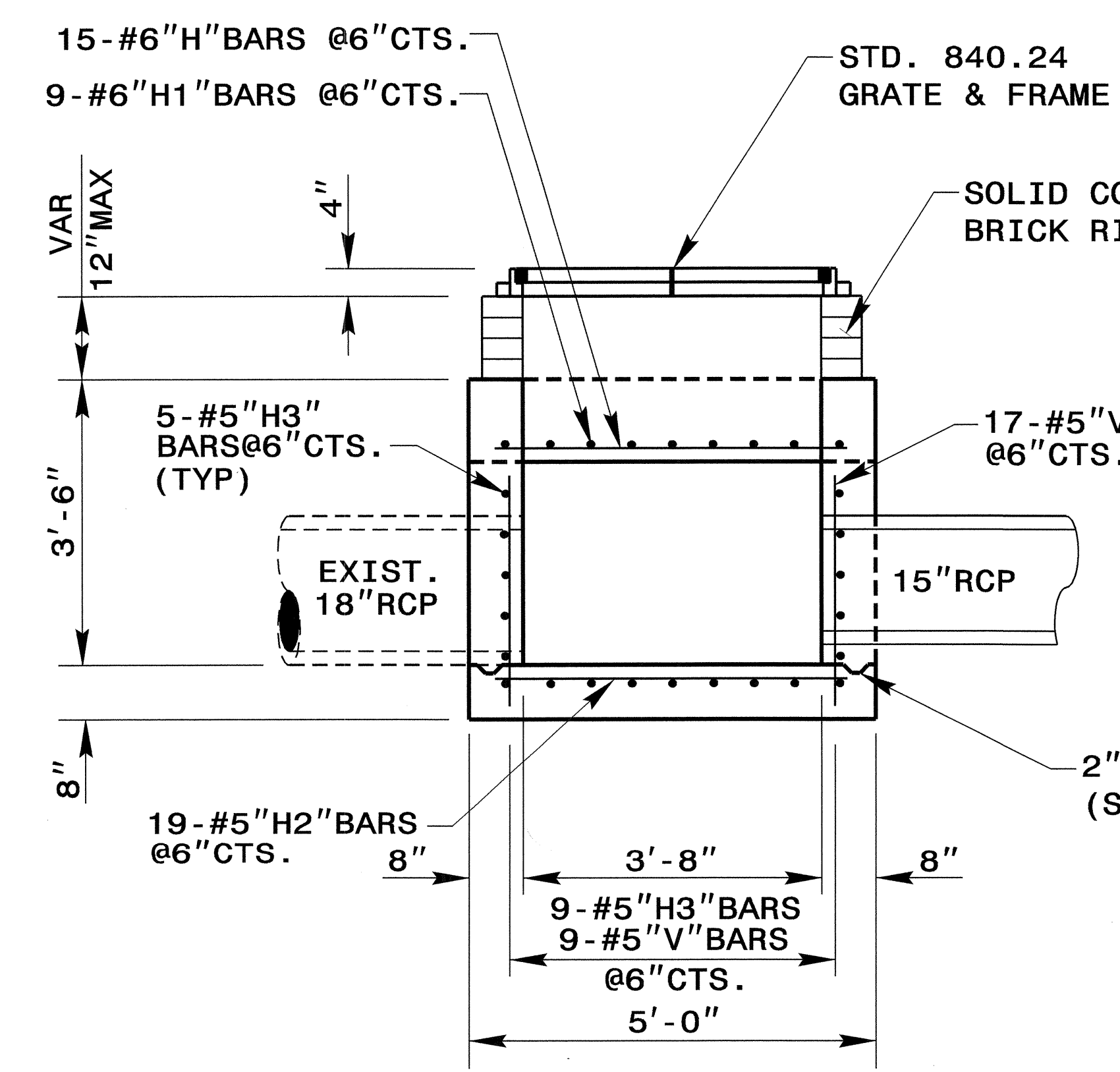

SECTION X-X

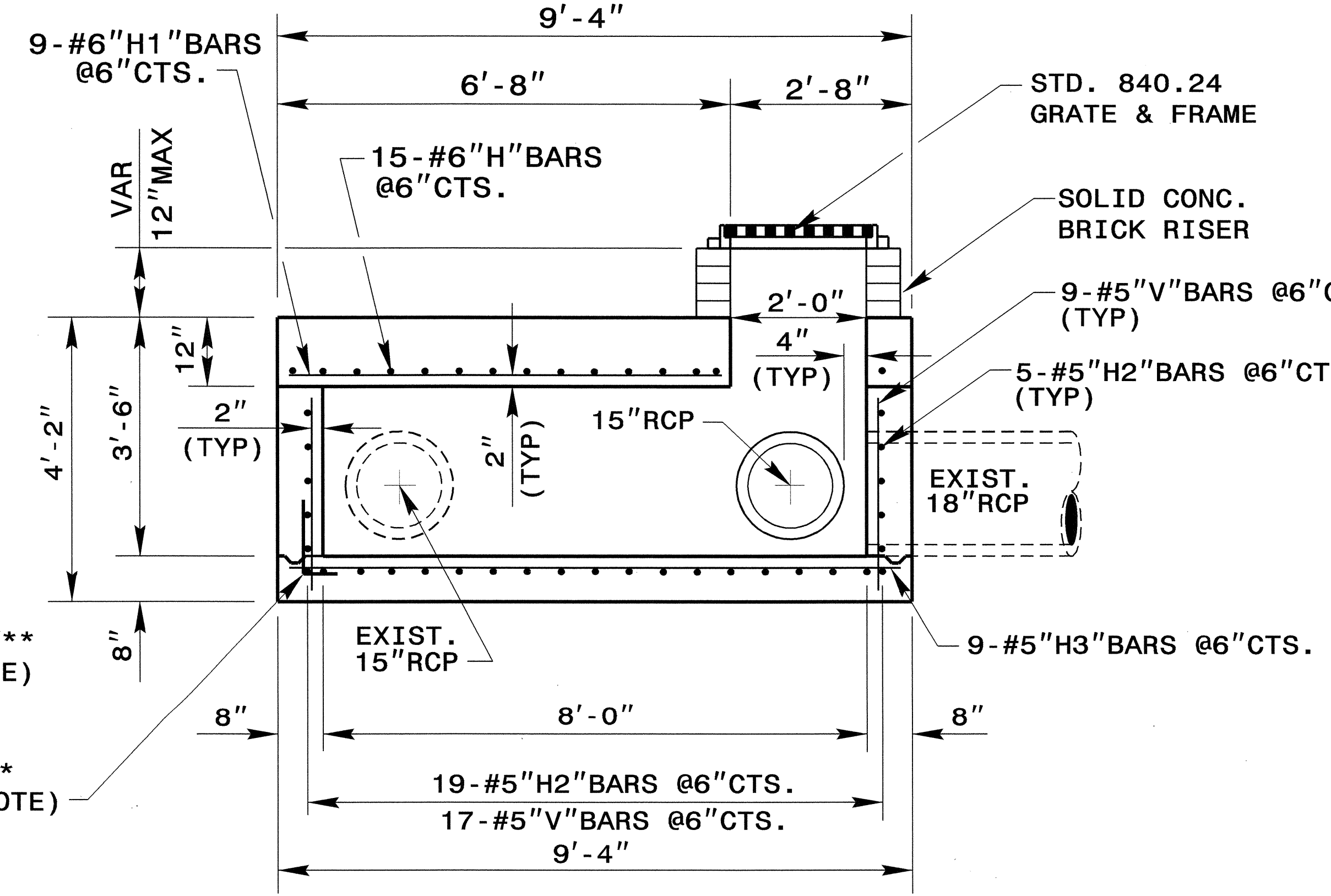

SECTION Y-Y

MASONRY: USE
 0.3 CU.YDS. PER FT.OF RISER (MIN)

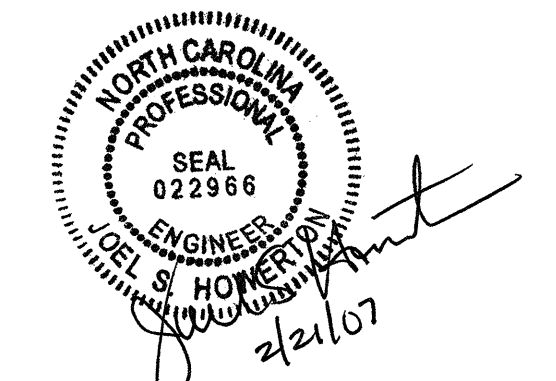

**PROJECT SERVICES UNIT
 STANDARDS AND SPECIAL DESIGN**
 Office 919-250-4128 FAX 919-250-4119

DETAIL OF 2 GI/TBJB

ORIGINAL BY: rnbritt DATE: 06-20-06
 MODIFIED BY: J.S.H. DATE: 1/16/07
 CHECKED BY: J.S.H. DATE: 1/16/07
 FILE SPEC.: g:\jalis\rnbritt\english\bridge\b4299_2gi_tbjb.dgn

16-JAN-2007 09:48
 g:\jalis\rnbritt\english\bridge\b4299_2gi_tbjb.dgn
 16-JAN-2007 09:48
 g:\jalis\rnbritt\english\bridge\b4299_2gi_tbjb.dgn

STATE OF NORTH CAROLINA
DEPT. OF TRANSPORTATION
DIVISION OF HIGHWAYS
RALEIGH, N.C.

ENGLISH DETAIL DRAWING FOR
ANCHORAGE FOR FRAMES
BRICK/CONCRETE/PRECAST CONCRETE

SHEET 1 OF 1
840D25

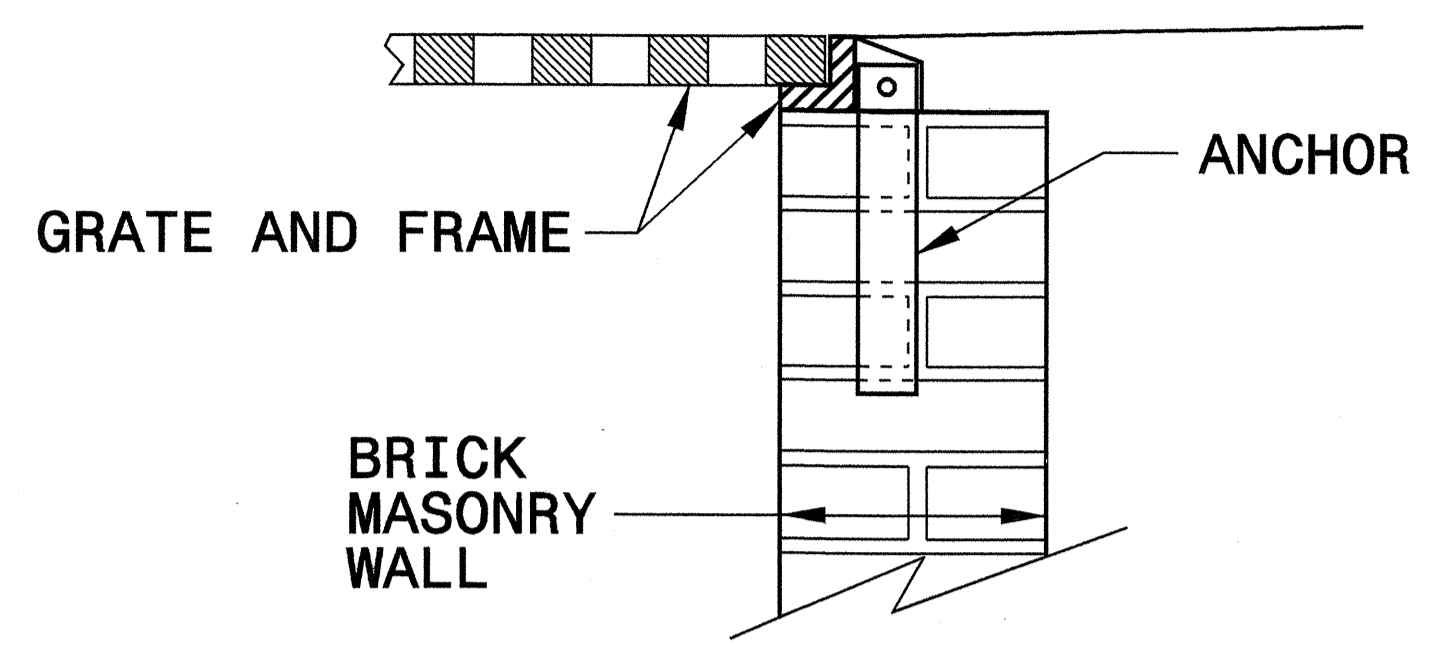

BRICK MASONRY CONSTRUCTION

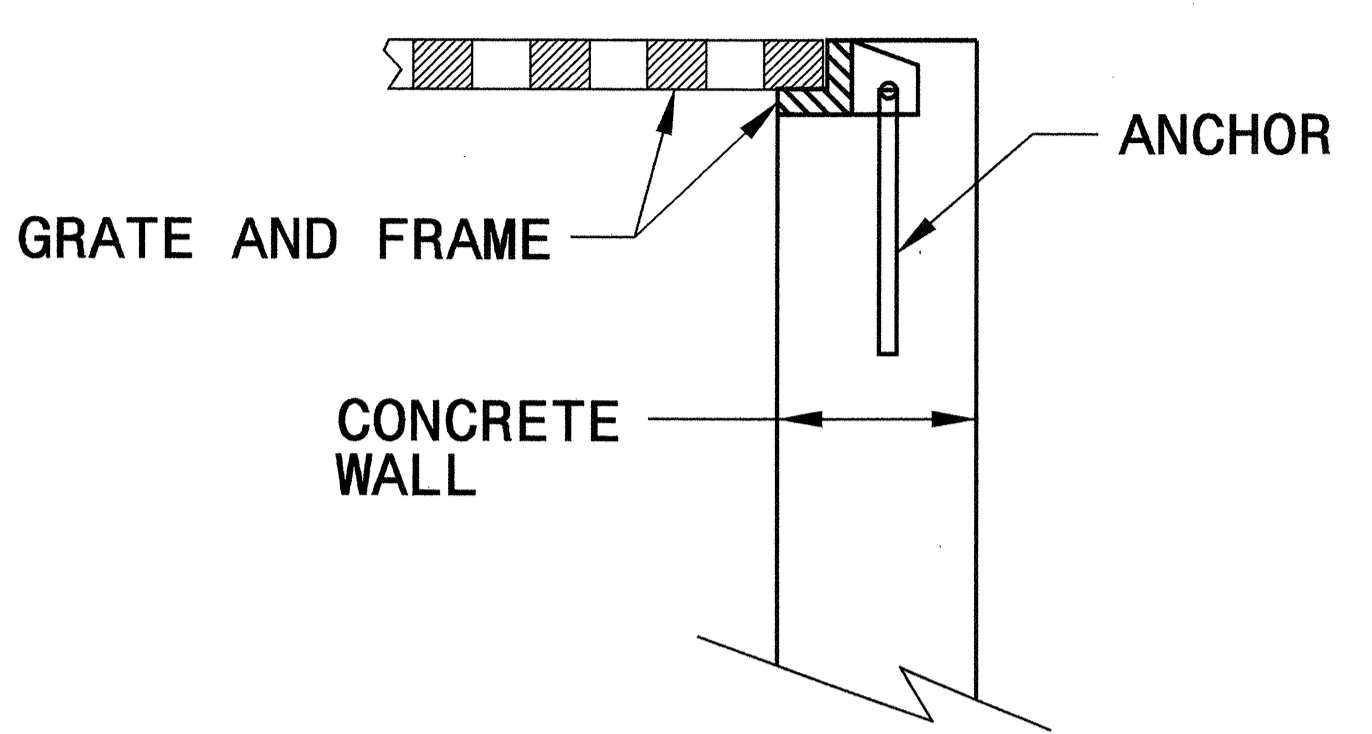

CONCRETE CONSTRUCTION

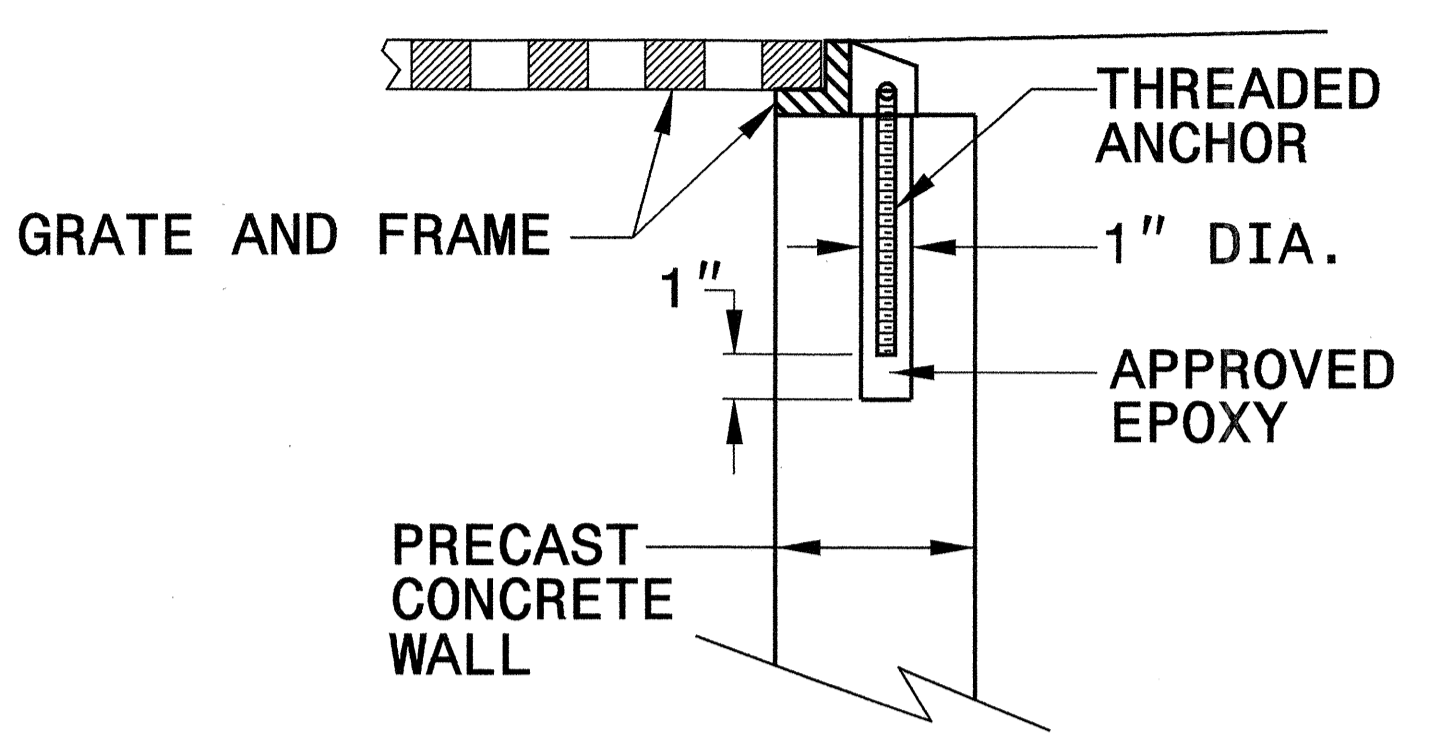

PRECAST CONCRETE CONSTRUCTION

DETAIL SHOWING ANCHORAGE OF FRAME FOR GRATED DROP INLET

NOTE:
CONSTRUCT GRATED DROP INLET TO COINCIDE WITH NORMAL OR SUPERELEVATED SHOULDER OR PAVEMENT SLOPE.

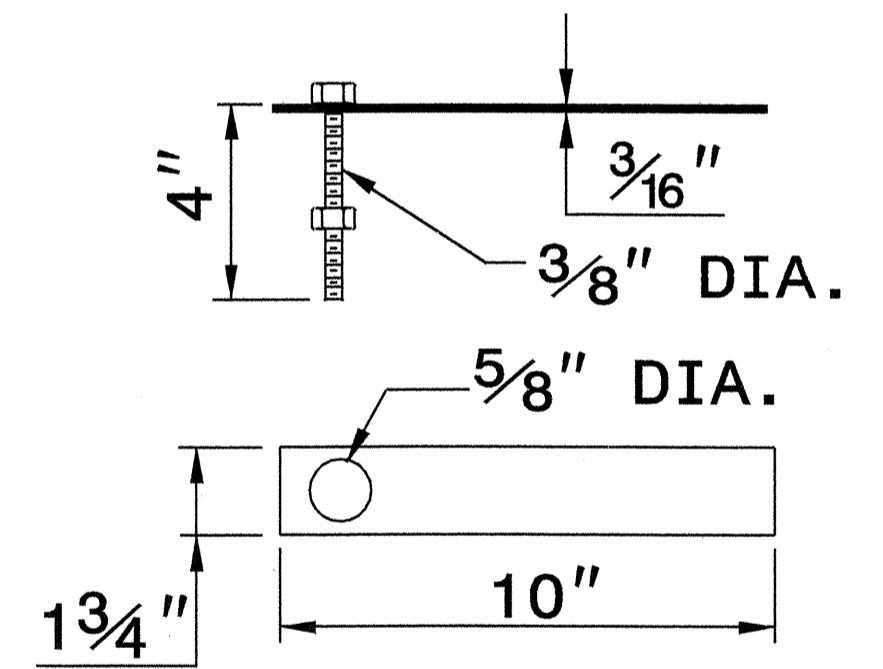

MASONRY ANCHOR
3/8" DIA. BOLT WITH PLATE

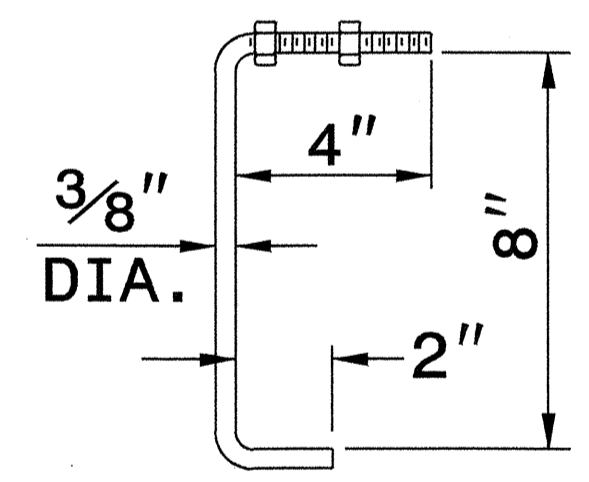

CONCRETE ANCHOR
3/8" DIA. BENT BAR

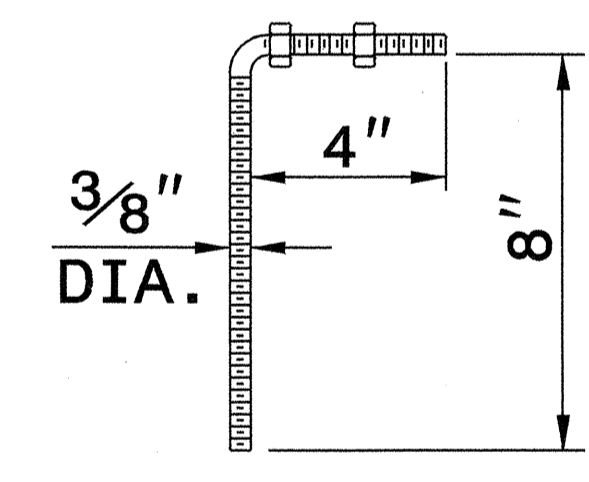

PRECAST CONCRETE ANCHOR
3/8" DIA. BENT BAR

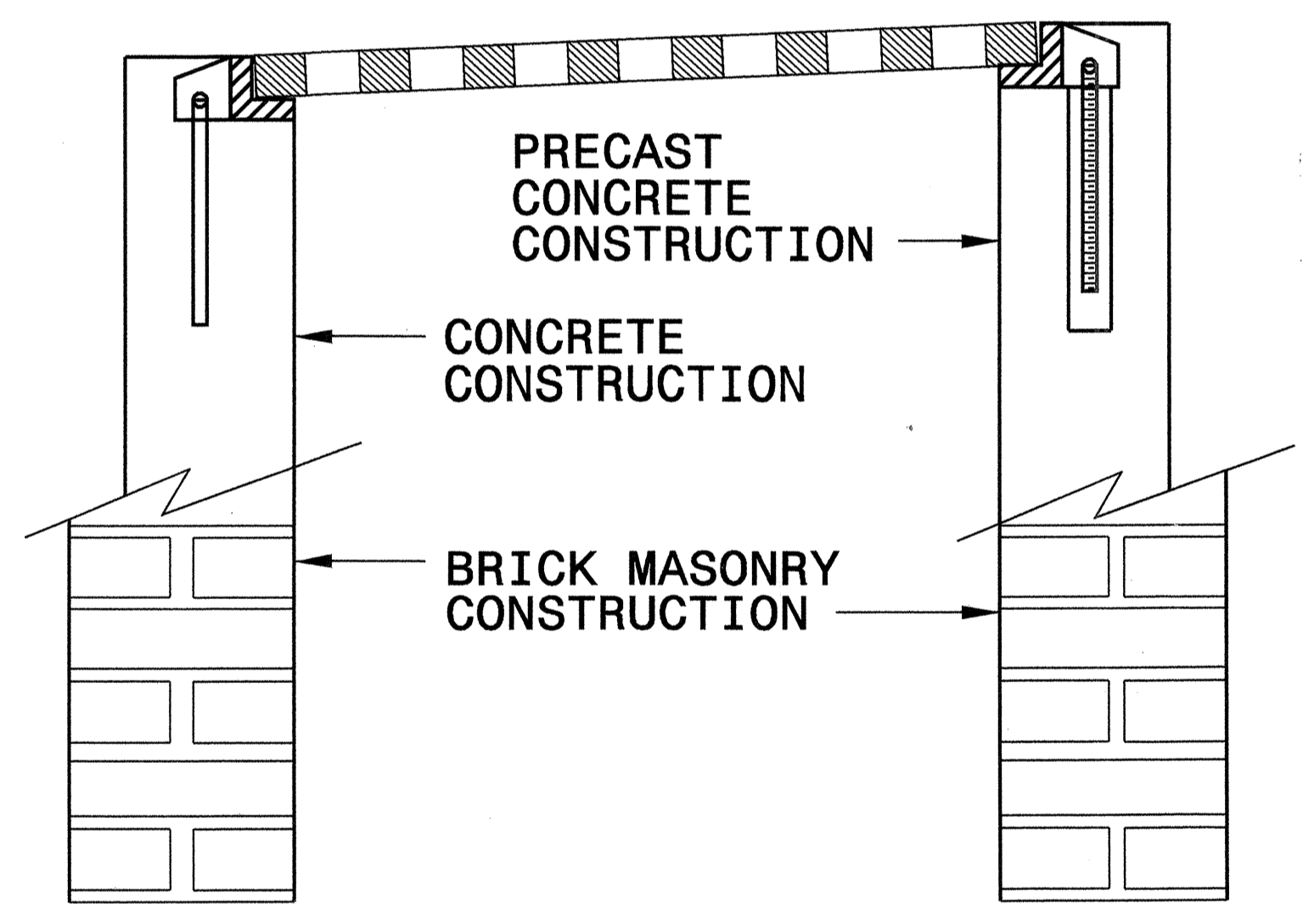

FRAME AND GRATE INSTALLATION FOR NORMAL CROWN AND SUPERELEVATED SECTIONS

STATE OF NORTH CAROLINA
DEPT. OF TRANSPORTATION
DIVISION OF HIGHWAYS
RALEIGH, N.C.

ENGLISH DETAIL DRAWING FOR
ANCHORAGE FOR FRAMES
BRICK/CONCRETE/PRECAST CONCRETE

SHEET 1 OF 1
840D25

27-SEP-2006 09:01
z:\c:\projects\concrete\special details\ward\stds\06\stds to special details\840d25 Anchorage for Frames\0840d25.dgn
ward

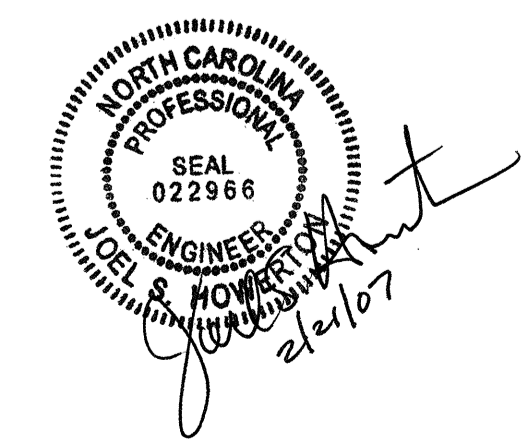

**PROJECT SERVICES UNIT
STANDARDS AND SPECIAL DESIGN**
Office 919-250-4128 FAX 919-250-4119

SEE PLATE FOR TITLE

ORIGINAL BY: 2006 STD 840.25 DATE: 07/18/06
 MODIFIED BY: E.E. WARD DATE: 9/25/06
 CHECKED BY: J.E. Ward DATE: 9/27/06
 FILE SPEC.: J.E. Ward

SUMMARY OF QUANTITIES

ItemNumber	Sec #	Quantity	Unit	Description
0000100000-N	800	Lump Sum		MOBILIZATION
0029000000-N	SP	Lump Sum		REINFORCED BRIDGE APPROACH FILL, STATION ***** (22+70.00)
0043000000-N	226	Lump Sum		GRADING
0050000000-E	226	1	ACR	SUPPLEMENTARY CLEARING & GRUB-BING
0057000000-E	226	200	CY	UNDERCUT EXCAVATION
0080000000-E	SP	100	TON	CLASS IV SUBGRADE STABILIZATION
0134000000-E	240	65	CY	DRAINAGE DITCH EXCAVATION
0195000000-E	265	100	CY	SELECT GRANULAR MATERIAL
0196000000-E	270	100	SY	FABRIC FOR SOIL STABILIZATION
0318000000-E	300	40	TON	FOUNDATION CONDITIONING MATERIAL, MINOR STRS
0366000000-E	310	80	LF	15" RC PIPE CULVERTS, CLASS III
0372000000-E	310	56	LF	18" RC PIPE CULVERTS, CLASS III
0378000000-E	310	200	LF	24" RC PIPE CULVERTS, CLASS III
0708000000-E	310	20	LF	15" BIT COAT CS PIPE CULVERTS, TYPE B 0.064" THICK
0806000000-E	310	2	EA	15" BIT COAT CS PIPE ELBOWS, TYPE B 0.064" THICK
0995000000-E	340	187	LF	PIPE REMOVAL
1220000000-E	545	100	TON	INCIDENTAL STONE BASE
1297000000-E	607	185	SY	MILLING ASPHALT PAVEMENT, **** DEPTH (1-1/2")
1330000000-E	607	300	SY	INCIDENTAL MILLING
1489000000-E	610	540	TON	ASPHALT CONC BASE COURSE, TYPE B25.0B
1491000000-E	610	130	TON	ASPHALT CONC BASE COURSE, TYPE B25.0C
1498000000-E	610	320	TON	ASPHALT CONC INTERMEDIATE COURSE, TYPE I19.0B
1503000000-E	610	65	TON	ASPHALT CONC INTERMEDIATE COURSE, TYPE I19.0C
1519000000-E	610	440	TON	ASPHALT CONC SURFACE COURSE, TYPE S9.5B
1523000000-E	610	80	TON	ASPHALT CONC SURFACE COURSE, TYPE S9.5C
1560000000-E	620	74	TON	ASPHALT BINDER FOR PLANT MIX, GRADE PG 64-22
1565000000-E	620	5	TON	ASPHALT BINDER FOR PLANT MIX, GRADE PG 70-22
1693000000-E	654	55	TON	ASPHALT PLANT MIX, PAVEMENT REPAIR
2000000000-N	806	4	EA	RIGHT OF WAY MARKERS
2022000000-E	815	25	CY	SUBDRAIN EXCAVATION
2033000000-E	815	20	CY	SUBDRAIN FINE AGGREGATE
2044000000-E	815	100	LF	6" PERFORATED SUBDRAIN PIPE
2055000000-E	815	3	EA	6" SUBDRAIN PIPE WYES, TEES, & ELBOWS
2066000000-N	815	1	EA	CONCRETE PAD FOR SUBDRAIN PIPE OUTLET
2077000000-E	815	6	LF	6" OUTLET PIPE (SUBDRAINS)
2286000000-N	840	5	EA	MASONRY DRAINAGE STRUCTURES
2366000000-N	840	2	EA	FRAME WITH TWO GRATES, STD 840.24
2367000000-N	840	3	EA	FRAME WITH TWO GRATES, STD 840.29
2566000000-E	846	75	LF	SHOULDER BERM GUTTER
2577000000-E	846	120	LF	CONCRETE EXPRESSWAY GUTTER
3030000000-E	862	187.5	LF	STEEL BM GUARDRAIL
3045000000-E	862	100	LF	STEEL BM GUARDRAIL, SHOP CURVED
3150000000-N	862	5	EA	ADDITIONAL GUARDRAIL POSTS
3195000000-N	862	2	EA	GUARDRAIL ANCHOR UNITS, TYPE AT-1
3270000000-N	SP	2	EA	GUARDRAIL ANCHOR UNITS, TYPE 350
3317000000-N	862	4	EA	GUARDRAIL ANCHOR UNITS, TYPE B-77
3566000000-E	867	330	LF	WOVEN WIRE FENCE RESET

ItemNumber	Sec #	Quantity	Unit	Description
3649000000-E	876	10	TON	RIP RAP, CLASS B
3656000000-E	876	190	SY	FILTER FABRIC FOR DRAINAGE
3659000000-N	SP	2	EA	PERFORMED SCOUR HOLES WITH LEVEL SPREADER APRON
4400000000-E	1110	439	SF	WORK ZONE SIGNS (STATIONARY)
4405000000-E	1110	288	SF	WORK ZONE SIGNS (PORTABLE)
4410000000-E	1110	119	SF	WORK ZONE SIGNS (BARRICADE MOUNTED)
4415000000-N	1115	2	EA	FLASHING ARROW PANELS, TYPE C
4422000000-N	1120	56	DAY	CHANGEABLE MESSAGE SIGN (SHORT TERM)
4430000000-N	1130	80	EA	DRUMS
4445000000-E	1145	112	LF	BARRICADES (TYPE III)
4450000000-N	1150	32	HR	FLAGGER
4510000000-N	SP	32	HR	POLICE
4650000000-N	1251	12	EA	TEMPORARY RAISED PAVEMENT MARKERS
4685000000-E	1205	3,106	LF	THERMOPLASTIC PAVEMENT MARKING LINES (4", 90 MILS)
4686000000-E	1205	3,679	LF	THERMOPLASTIC PAVEMENT MARKING LINES (4", 120 MILS)
4695000000-E	1205	55	LF	THERMOPLASTIC PAVEMENT MARKING LINES (8", 90 MILS)
4710000000-E	1205	117	LF	THERMOPLASTIC PAVEMENT MARKING LINES (24", 120 MILS)
4725000000-E	1205	8	EA	THERMOPLASTIC PAVEMENT MARKING SYMBOL (90 MILS)
4810000000-E	1205	1,845	LF	PAINT PAVEMENT MARKING LINES (4")
4820000000-E	1205	394	LF	PAINT PAVEMENT MARKING LINES (8")
4835000000-E	1205	108	LF	PAINT PAVEMENT MARKING LINES (24")
4845000000-N	1205	4	EA	PAINT PAVEMENT MARKING SYMBOL
4850000000-E	1205	1,851	LF	REMOVAL OF PAVEMENT MARKING LINES (4")
4860000000-E	1205	197	LF	REMOVAL OF PAVEMENT MARKING LINES (8")
4870000000-E	1205	52	LF	REMOVAL OF PAVEMENT MARKING LINES (24")
4875000000-N	1205	2	EA	REMOVAL OF PAVEMENT MARKING SYMBOLS & CHARACTERS
4900000000-N	1251	45	EA	PERMANENT RAISED PAVEMENT MARKERS
5255000000-N	1413	Lump Sum		PORTABLE LIGHTING
6000000000-E	1605	1,090	LF	TEMPORARY SILT FENCE
6006000000-E	1610	150	TON	STONE FOR EROSION CONTROL, CLASS A
6009000000-E	1610	255	TON	STONE FOR EROSION CONTROL, CLASS B
6012000000-E	1610	185	TON	SEDIMENT CONTROL STONE
6015000000-E	1615	0.5	ACR	TEMPORARY MULCHING
6018000000-E	1620	50	LB	SEED FOR TEMPORARY SEEDING
6021000000-E	1620	0.25	TON	FERTILIZER FOR TEMPORARY SEEDING
6024000000-E	1622	15	LF	TEMPORARY SLOPE DRAINS
6027000000-N	1622	1	EA	INLET PROTECTION AT TEMPORARY SLOPE DRAINS
6029000000-E	SP	350	LF	SAFETY FENCE
6030000000-E	1630	1,270	CY	SILT EXCAVATION
6036000000-E	1631	650	SY	MATting FOR EROSION CONTROL
6037000000-E	SP	10	SY	COIR FIBER MAT
6038000000-E	SP	265	SY	PERMANENT SOIL REINFORCEMENT MAT
6071030000-E	SP	350	LF	COIR FIBER BAFFLES
6071050000-E	SP	1	EA	*** SKIMMER (2")
6084000000-E	1660	0.5	ACR	SEEDING & MULCHING
6087000000-E	1660	0.5	ACR	MOWING
6090000000-E	1661	50	LB	SEED FOR REPAIR SEEDING
6093000000-E	1661	0.25	TON	FERTILIZER FOR REPAIR SEEDING

ItemNumber	Sec #	Quantity	Unit	Description
6096000000-E	1662	50	LB	SEED FOR SUPPLEMENTAL SEEDING
6108000000-E	1665	0.5	TON	FERTILIZER TOPDRESSING
6114000000-N	SP	2	HR	SPECIALIZED HAND MOWING
6117000000-N	SP	8	EA	RESPONSE FOR EROSION CONTROL
6123000000-E	1670	0.1	ACR	REFORESTATION
7060000000-E	1705	170	LF	SIGNAL CABLE
7120000000-E	1705	1	EA	VEHICLE SIGNAL HEAD (12", 3 SECTION)
7144000000-E	1705	1	EA	VEHICLE SIGNAL HEAD (12", 5 SECTION)
7300000000-E	1715	20	LF	UNPAVED TRENCHING (***** (1, 2"))
7324000000-N	1716	1	EA	JUNCTION BOX (STANDARD SIZE)
7420000000-E	1722	1	EA	2" RISER WITH WEATHERHEAD
7444000000-E	1725	60	LF	INDUCTIVE LOOP SAWCUT
7456000000-E	1726	380	LF	LEAD-IN CABLE (***** (18-2))
7636000000-N	1745	3	EA	SIGN FOR SIGNALS

REVISIONS

PROJECT REFERENCE NO.		SHEET NO.	
B-4299		4	
ROADWAY DESIGN ENGINEER		HYDRAULICS ENGINEER	

SR 1006/ SR 2782 TRAFFIC DATA

SR 2782 LEGEND RD.

702 1101	2307 3704	2307 3704	3711 6907
4413 8007	702 1101	3711 6907	6018 10610

SR 1006 OLD STAGE RD.

ADT $\frac{2007}{2027}$ (IN HUNDREDS)

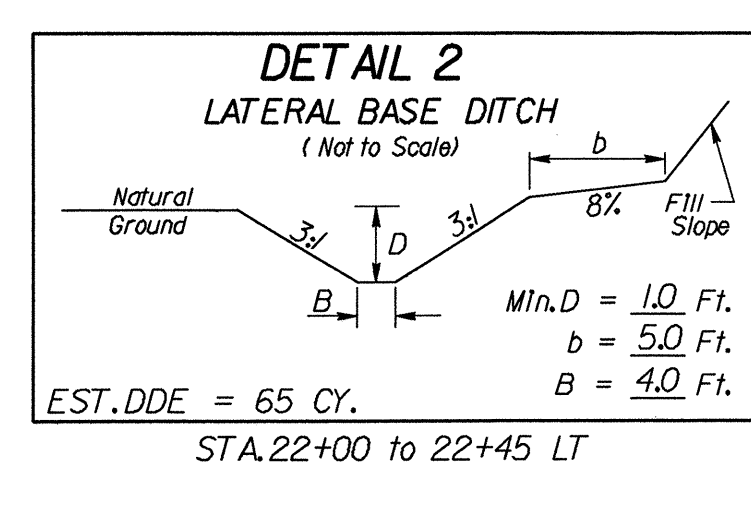
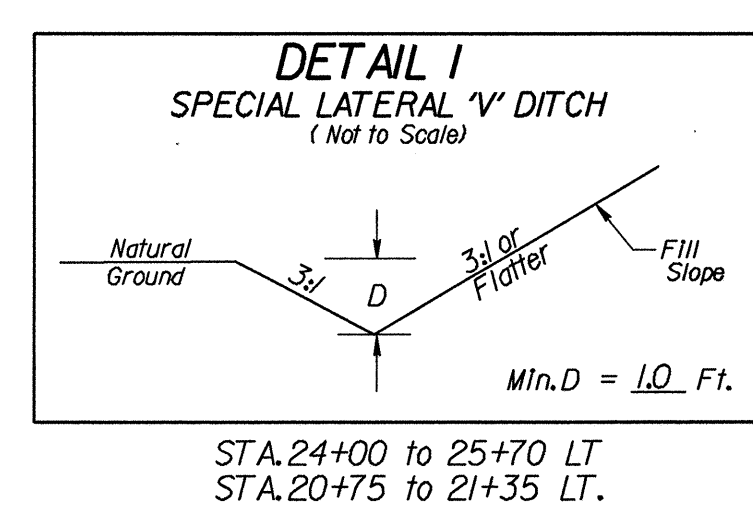
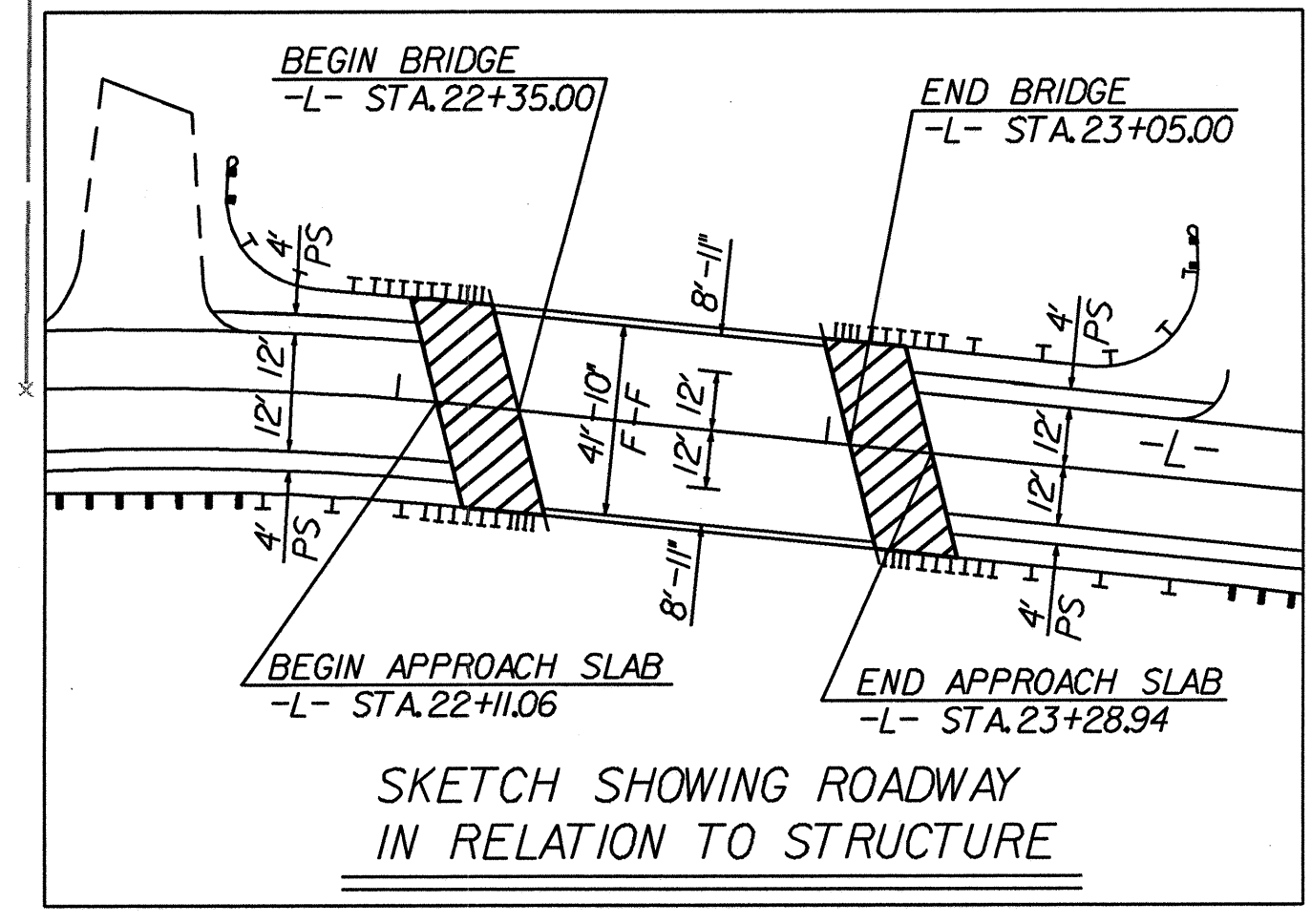
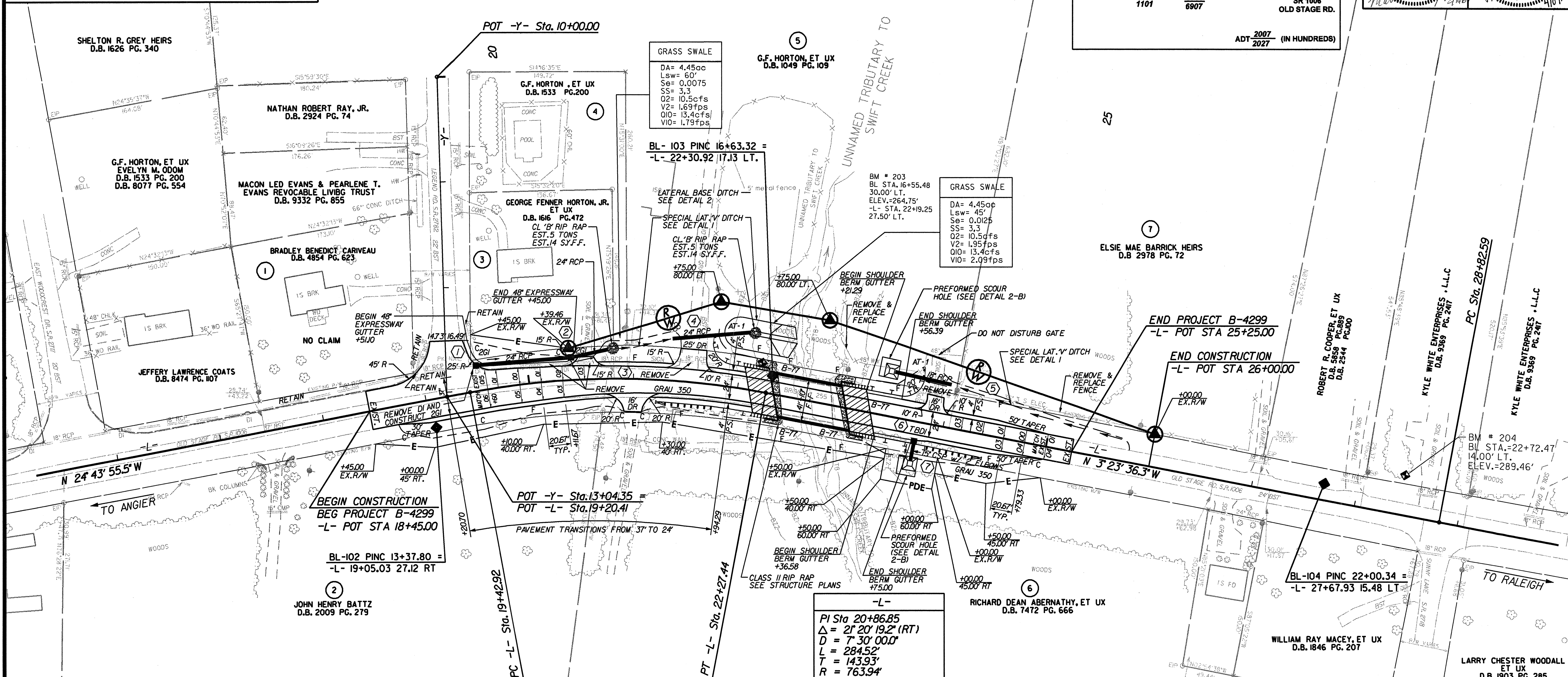

DENOTES APPROACH SLAB

SEE SHEET NO. 6 FOR PROFILE

SEE SHEETS S-1 THRU S-19 FOR STRUCTURE PLANS

<p>TRAN SITE CONSULTING ENGINEERS, INCORPORATED 1900 Padlock Drive, Suite G-10 Raleigh, N.C. 27609</p>	<p>RAMEY KEMP & ASSOCIATES, INC. TRANSPORTATION ENGINEERS 3808 Foreground Place Raleigh, North Carolina 27609 919-872-5115 Fax: 919-872-5418 Fax: 2100000000</p>
---	---

10/26/98

REVISIONS

PROJECT REFERENCE NO. B-4299	SHEET NO. 5
RW SHEET NO.	
ROADWAY DESIGN ENGINEER NORTH CAROLINA PROFESSIONAL SEAL 27771 M. B. COPP	HYDRAULICS ENGINEER NORTH CAROLINA PROFESSIONAL SEAL 18442 M. LEON BOLLINGER

 MILLING AND OVERLAY

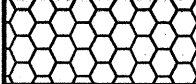
 FULL DEPTH PAVEMENT SECTION

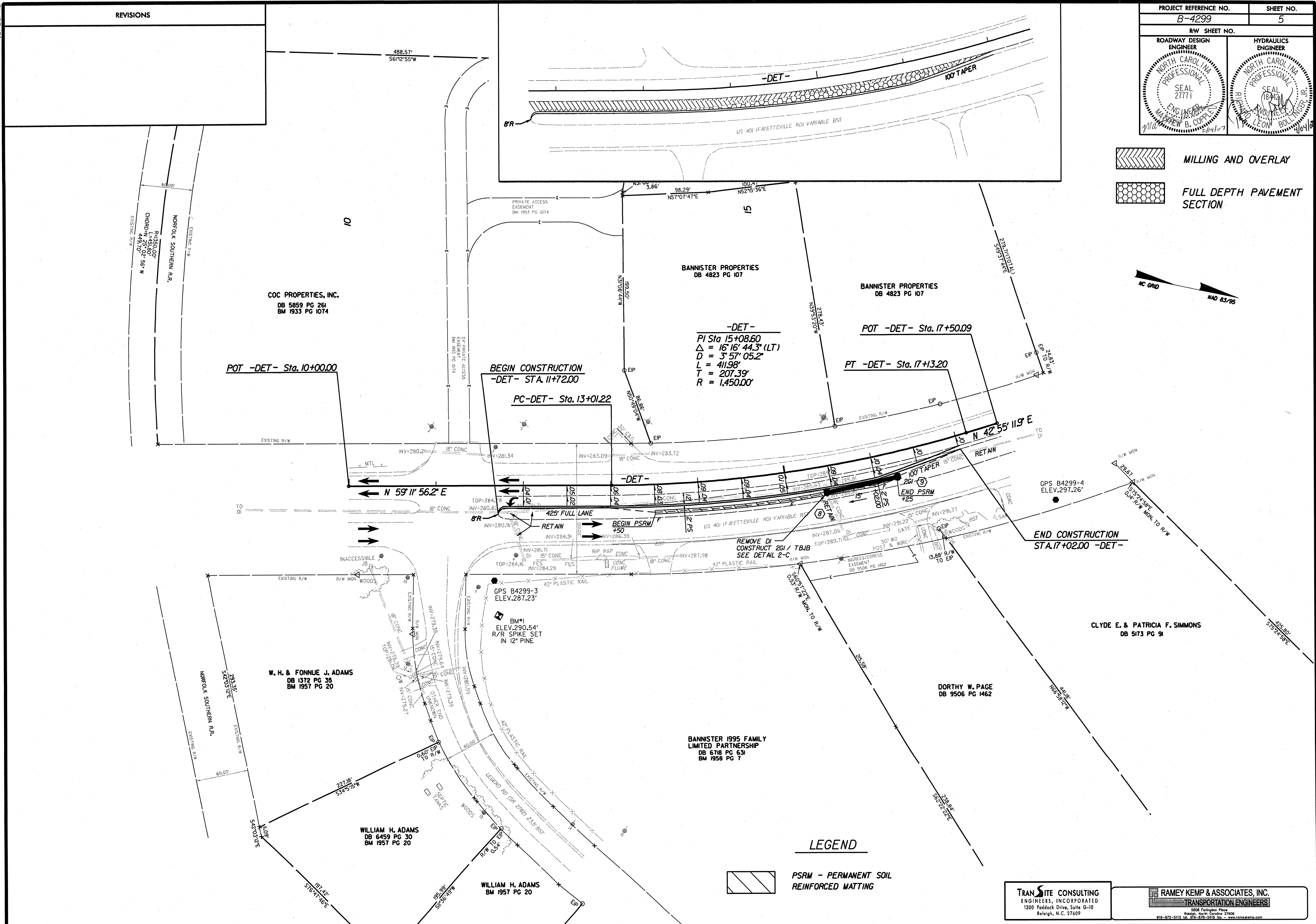
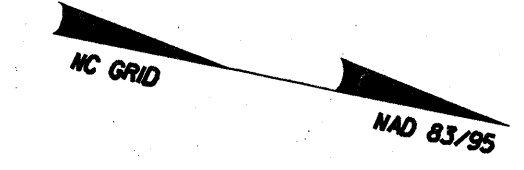

LEGEND

 PSRM - PERMANENT SOIL REINFORCED MATTING

TRAN SITE CONSULTING
ENGINEERS, INCORPORATED
1300 Paddock Drive, Suite G-10
Raleigh, N.C. 27609

RAMEY KEMP & ASSOCIATES, INC.
TRANSPORTATION ENGINEERS
5308 Farrington Place
Raleigh, North Carolina 27608
919-872-5115 tel. 919-878-5418 fax - www.rkemp.com

B.M.*203 ELEV. = 26475
RR SPIKE IN BASE OF
42" SWEET GUM
30.00' LT. OF -BL- STA. 16+55.48
27.50' LT. OF -L- STA. 22+19.25

B.M.*204 ELEV. = 289.46
RR SPIKE IN BASE OF
14" SWEET GUM
14.00' LT. OF -BL- STA. 22+72.47
38.03' LT. OF -L- STA. 28+42.61

BRIDGE HYDRAULIC DATA	
DESIGN DISCHARGE	= 1600 CFS
DESIGN FREQUENCY	= 25 YRS
DESIGN HW ELEVATION	= 265.9 FT.
BASE DISCHARGE	= 1900 CFS
BASE FREQUENCY	= 100 YRS
BASE HW ELEVATION	= 266.3 FT
OVERTOPPING DISCHARGE	= 2300 CFS
OVERTOPPING FREQUENCY	= 200+/-YR.
OVERTOPPING ELEVATION	= 266.73 FT
DATE OF SURVEY	4-20-04
W.S.ELEVATION AT DATE OF SURVEY	= 256.76 FT

DITCH LEGEND
- - - - - DITCH GRADE LT

300
290

300
290

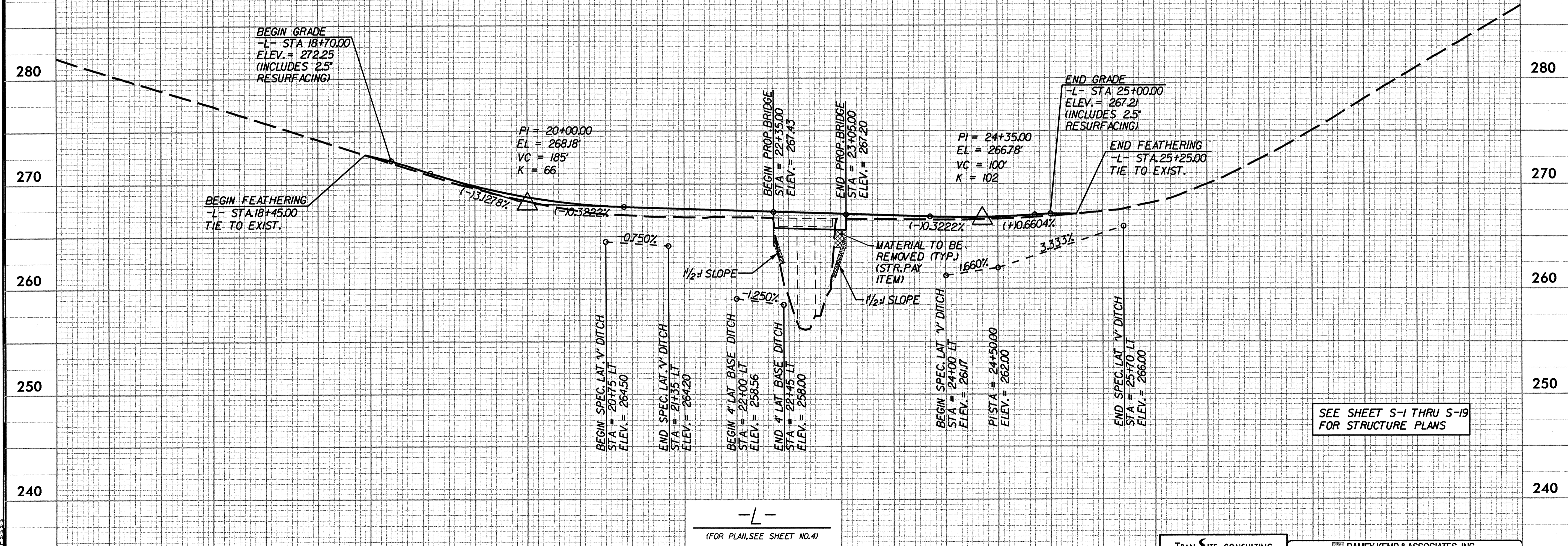

SEE SHEET S-1 THRU S-19
FOR STRUCTURE PLANS

-L-
(FOR PLAN, SEE SHEET NO. 4)