

Pavement Marking Schedule
TIP Project # B-3453

SYMBOL	DESCRIPTION	FINAL	PAY ITEM QUANTITY	TOTAL
PAVEMENT MARKINGS				
THERMOPLASTIC (4", 90 MILS)				
TA	WHITE EDGELINE		5474 LF	TOTAL 5474 LF
THERMOPLASTIC (4", 120 MILS)				
TD	2 FT. WHITE MINISKIP		20 LF	TOTAL 7039 LF
TE	WHITE SOLID LANE LINE		175 LF	
TI	YELLOW DOUBLE CENTER		6844 LF	
THERMOPLASTIC (8", 90 MILS)				
TT	YELLOW DIAGONAL		76 LF	TOTAL 76 LF
THERMOPLASTIC PAVEMENT MARKING SYMBOLS (90 MILS)				
UA	LEFT TURN ARROW		1 EA	TOTAL 1 EA
POLYUREA (4", 20MLS)				
VA	WHITE EDGELINE		926 LF	TOTAL 1852 LF
VI	YELLOW DOUBLE CENTER		926 LF	
MARKERS				
PERMANENT RAISED PAVEMENT MARKERS				
MA	YELLOW & YELLOW		92 EA	TOTAL 97 EA
MB	CRYSTAL & RED		5 EA	

NOTE:
REFER TO ROADWAY STANDARD DRAWING NO. 1250.01 AND 1251.01 FOR THE PLACEMENT OF FINAL PAVEMENT MARKERS.

APPROVED: <i>Said Yigit</i> DATE: 01-10-05	FINAL PAVEMENT MARKING SCHEDULE	
	SCALE: NONE	
	DATE: 02-20-03	
	DWG. BY: GFK	
	DESIGN BY: GFK	
REVIEWED BY: RWP	REVISIONS	<small>CARD FILE</small> PM1.DGN

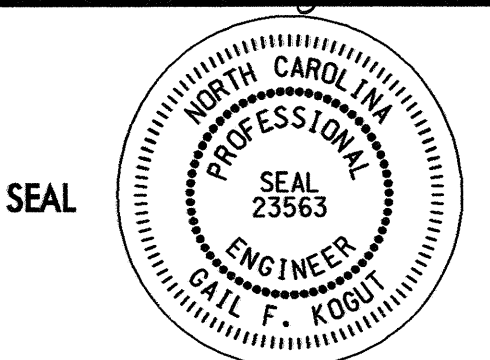
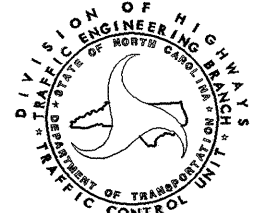
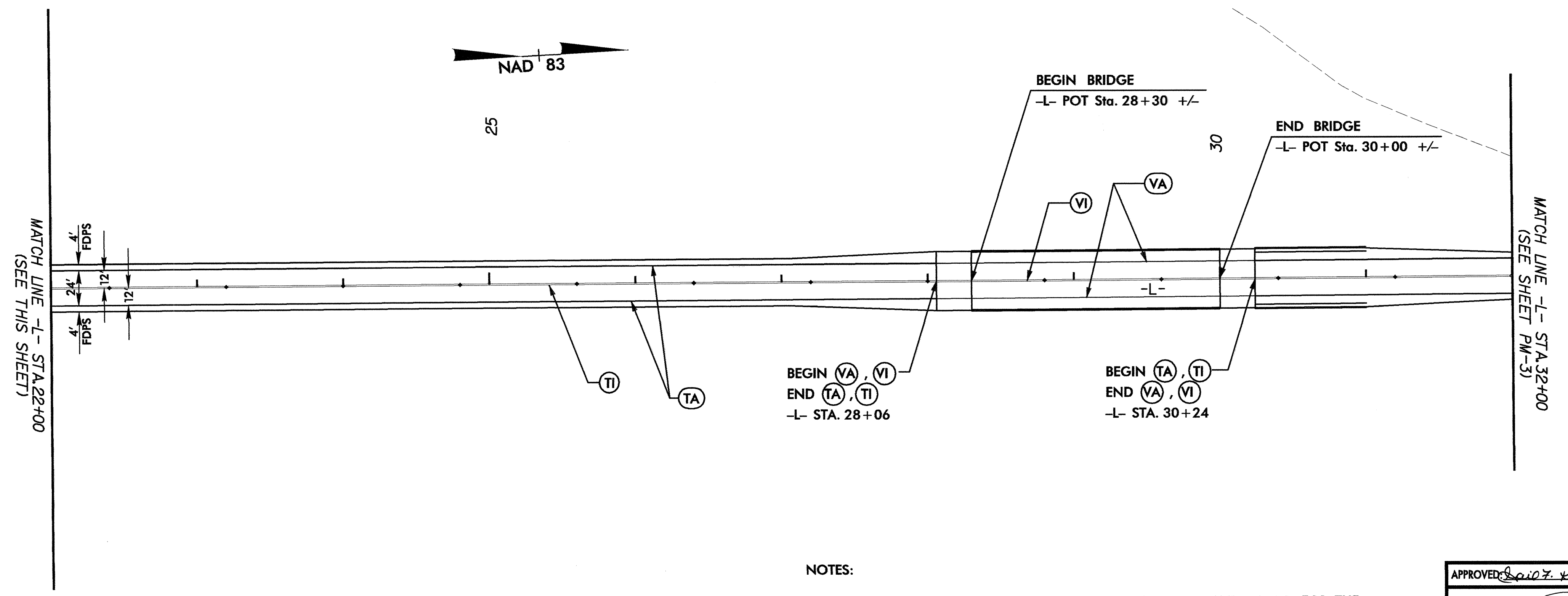
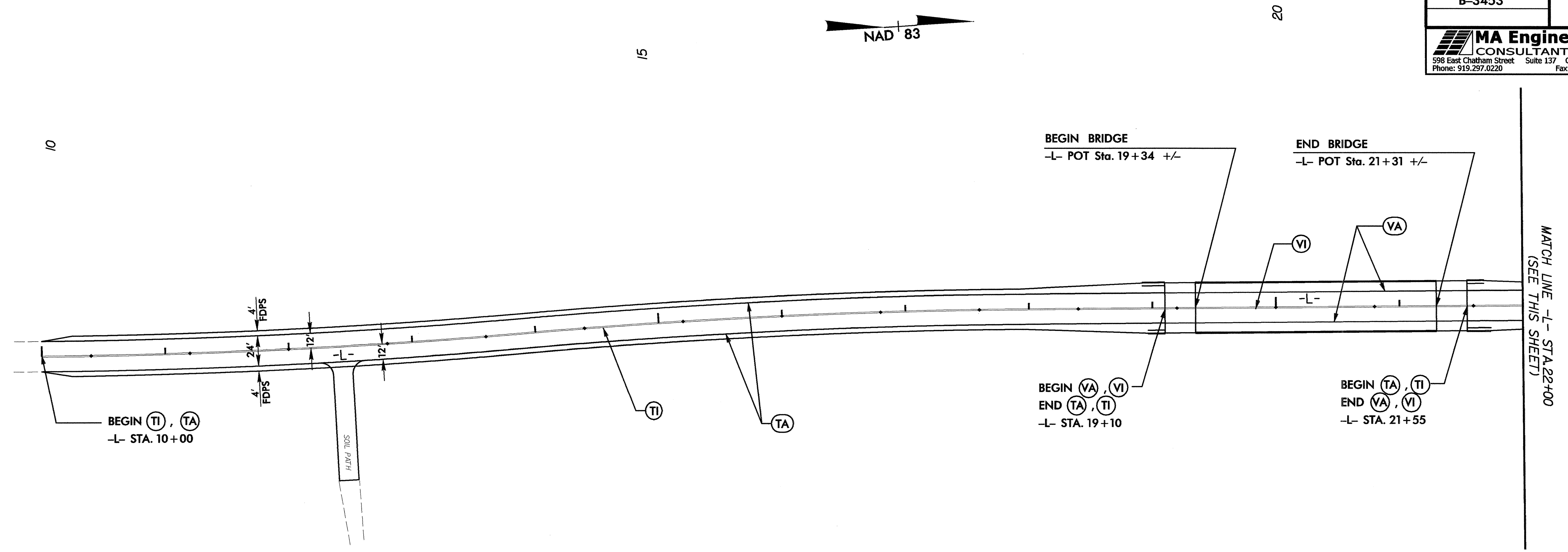

- NOTES:
1. REFER TO ROADWAY STANDARD DRAWING NO. 1250.01 AND 1251.01 FOR THE PLACEMENT OF FINAL PAVEMENT MARKERS.
 2. TIE PROPOSED PAVEMENT MARKINGS INTO EXISTING.
 3. SEE PM-1 FOR FINAL PAVEMENT MARKING SCHEDULE.

APPROVED: <i>[Signature]</i> DATE: 01-10-03	FINAL PAVEMENT MARKING PLANS		REVISIONS	
			SCALE: NONE	
	DATE: 01-20-03			
	DWG. BY: GFK			
DESIGN BY: GFK				
REVIEWED BY: RWP				
			CADD FILE	PM2.DGN

01/10/2005
 R:\Traffic\Tr-off\Control\TCP\107\pm2.dgn
 09:55:15 AM

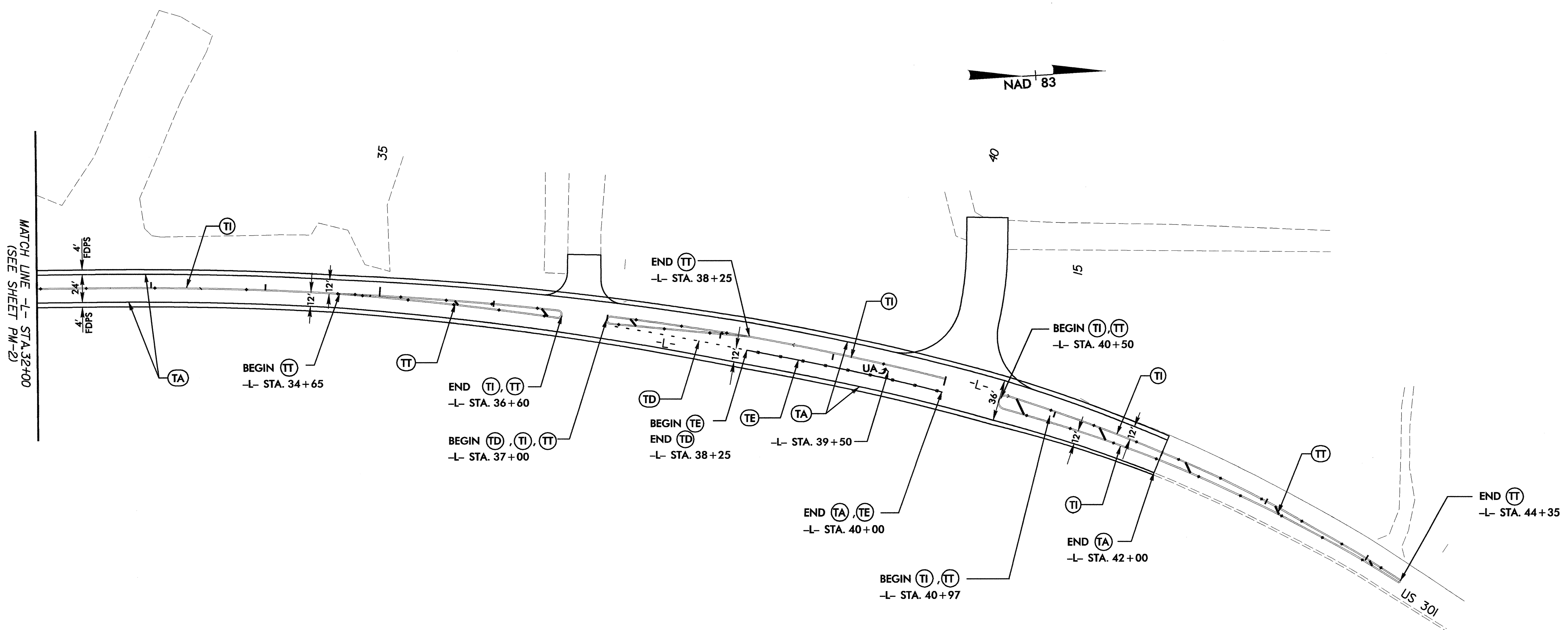

- NOTES:
1. REFER TO ROADWAY STANDARD DRAWING NO. 1250.01 AND 1251.01 FOR THE PLACEMENT OF FINAL PAVEMENT MARKERS.
 2. TIE PROPOSED PAVEMENT MARKINGS INTO EXISTING.
 3. SEE PM-1 FOR FINAL PAVEMENT MARKING SCHEDULE.

APPROVED <i>Paul F. Kogut</i> DATE: 01-10-05	<h2 style="text-align: center;">FINAL PAVEMENT MARKING PLANS</h2>		REVISIONS	
SCALE: NONE	DATE: 01-20-03	DESIGN BY: GFK		
	DESIGN BY: GFK	REVIEWED BY: RWP		
		CADD FILE: PM3.DGN		

01/10/2005 09:17:44 AM C:\TrafficControl\TCR\1107\pm3.dgn
 03:55:06 AM