

STATE OF NORTH CAROLINA
DIVISION OF HIGHWAYS

STATE PROJECT REFERENCE NO.	SHEET NO.
U-3344 A	TCP-1

U-3344 A

**PLAN FOR PROPOSED
TRAFFIC CONTROL, MARKING & DELINEATION
WAKE COUNTY**

ROADWAY STANDARD DRAWINGS

THE FOLLOWING ROADWAY STANDARDS AS APPEAR IN "ROADWAY STANDARD DRAWINGS"- ROADWAY DESIGN UNIT-N.C. DEPARTMENT OF TRANSPORTATION-RALEIGH, N.C., DATED JULY 2006 ARE APPLICABLE TO THIS PROJECT AND BY REFERENCE HEREBY ARE CONSIDERED A PART OF THESE PLANS:

STD. NO.	TITLE
1101.02	TEMPORARY LANE CLOSURES
1101.03	TEMPORARY ROAD CLOSURES
1101.05	WORK ZONE VEHICLE ACCESSES
1101.11	TRAFFIC CONTROL DESIGN TABLES
1110.01	STATIONARY WORK ZONE SIGNS
1110.02	PORTABLE WORK ZONE SIGNS
1115.01	FLASHING ARROW PANELS
1130.01	DRUMS
1135.01	CONES
1145.01	BARRICADES
1150.01	FLAGGERS
1160.01	TEMPORARY CRASH CUSHION
1165.01	TRUCK MOUNTED IMPACT ATTENUATOR
1170.01	PORTABLE CONCRETE BARRIER
1205.01	PAVEMENT MARKINGS - LINE TYPES & OFFSETS
1205.02	PAVEMENT MARKINGS - 2 LANE & MULTILANE ROADWAYS
1205.04	PAVEMENT MARKINGS - INTERSECTIONS
1205.05	PAVEMENT MARKINGS - TURN LANES
1205.06	PAVEMENT MARKINGS - THRU LANE DROPS
1205.08	PAVEMENT MARKINGS - SYMBOLS & WORD MESSAGES
1205.09	PAVEMENT MARKINGS - PAINTED ISLANDS
1250.01	PAVEMENT MARKER SPACING
1251.01	RAISED PAVEMENT MARKERS (TEMPORARY & PERMANENT)
1261.01	GUARDRAIL & BARRIER DELINEATOR SPACING
1261.02	GUARDRAIL & BARRIER DELINEATOR TYPES
1262.01	GUARDRAIL END DELINEATION

INDEX OF SHEETS

SHEET NO.	TITLE
TCP-1	LIST OF APPLICABLE ROADWAY STANDARD DRAWINGS, LEGEND AND INDEX OF SHEETS
TCP-2	PROJECT NOTES
TCP-3	TEMPORARY PAVEMENT MARKING SCHEDULE
TCP-4 & 4A	PHASING
TCP-5 TO 8A	PHASE I
TCP-9 TO 11	PHASE II
TCP-12 TO 13	PHASE III
TCP-14	DETOUR ROUTE FOR WEEKEND CLOSURE OF AIRPORT BLVD.
TCP-15	BARRICADE LOCATIONS FOR WEEKEND CLOSURE OF AIRPORT BLVD.
TCP-16	WORK ZONE ADVANCED WARNING SIGNING
PMP-1	FINAL PAVEMENT MARKING SCHEDULE
PMP-2 TO 5	FINAL PAVEMENT MARKING PLANS

LEGEND

- GENERAL**
- DIRECTION OF TRAFFIC FLOW
 - NORTH ARROW
 - PROPOSED PVMT. EXIST. PVMT.
 - WORK AREA
 - REMOVAL OF EXISTING PAVEMENT
- TRAFFIC CONTROL DEVICES**
- TYPE I BARRICADE
 - TYPE II BARRICADE
 - TYPE III BARRICADE
 - CONE
 - DRUM
 - FLASHING ARROW PANEL (TYPE C)
 - TYPE 'B' WARNING LIGHT
 - STATIONARY SIGN
 - PORTABLE SIGN
 - STATIONARY OR PORTABLE SIGN
 - WARNING FLAGS
 - CRASH CUSHION
 - CHANGEABLE MESSAGE SIGN
 - TRUCK MOUNTED IMPACT ATTENUATOR (TMIA)
 - POLICE
 - FLAGGER
- PAVEMENT MARKINGS**
- CRYSTAL/CRYSTAL PAVEMENT MARKER
 - YELLOW/YELLOW PAVEMENT MARKER
 - CRYSTAL/RED PAVEMENT MARKER
 - PAVEMENT MARKING SYMBOLS

TIP PROJECT:



05-APR-2006 09:46
\\ets-cs03\U3344a\Traffic\TrafficControl\Top\U3344a-fc-top01.dgn
msteelman AT WZTC24162

APPROVED: DATE: April 5, 2006	PLAN PREPARED BY: N.C.D.O.T. TRAFFIC CONTROL, MARKING & DELINEATION UNIT
SEAL	J. S. BOURNE, P.E. TRAFFIC CONTROL ENGINEER
	J. S. KITE, P.E. TRAFFIC CONTROL PROJECT ENGINEER
	D. A. PARKER TRAFFIC CONTROL PROJECT DESIGN ENGINEER
	M. H. STEELMAN TRAFFIC CONTROL DESIGN ENGINEER / TECHNICIAN

TEMPORARY PAVEMENT MARKING SCHEDULE

SYMBOL	DESCRIPTION	PAY ITEM QUANTITY BREAKDOWN		TOTAL QUANTITY
TEMPORARY PAVEMENT MARKINGS				
PAINT (4")				
PA	WHITE EDGELINE (2X)	20004	LF	
PB	YELLOW EDGELINE (2X)	140	LF	
PC	10 FT. WHITE SKIP (1X)	1713	LF	
PD	2 FT. WHITE MINISKIP (2X)	516	LF	
PE	WHITE SOLID LANE LINE (2X)	1232	LF	
PF	10 FT. YELLOW SKIP (2X)	2150	LF	
PH	YELLOW SINGLE CENTER (1X)	8596	LF	
PI	YELLOW DOUBLE CENTER (2X)	31900	LF	
				TOTAL 66251 LF
PAINT (8")				
PR	WHITE GORELINE (2X)	2378	LF	
PS	WHITE DIAGONAL (1X)	643	LF	
PV	YELLOW DIAGONAL (2X)	338	LF	
				TOTAL 3359 LF
PAINT (24")				
P4	WHITE STOPBAR (2X)	405	LF	
				TOTAL 405 LF
PAINT MARKING CHARACTERS				
QI	ALPHANUMERIC CHAR. (1X)	32	EA	
				TOTAL 32 EA
PAINT MARKING SYMBOLS				
QA	LEFT TURN ARROW (2X)	38	EA	
QB	RIGHT TURN ARROW (2X)	23	EA	
				TOTAL 61 EA
MARKERS				
TEMPORARY RAISED PAVEMENT MARKERS				
MH	YELLOW & YELLOW	388	EA	
MI	CRYSTAL & RED	259	EA	
				TOTAL 647 EA

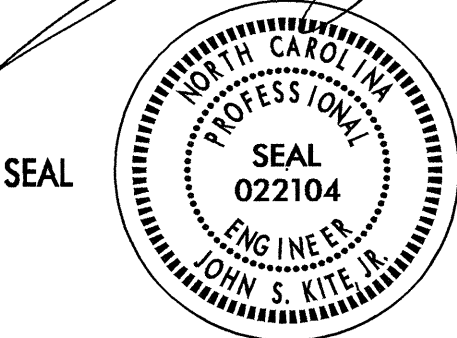
27-NOV-2006 15:55
 \\dot\dfsroot\proj\proj\projects-u\3344a\traffic\trafficcontrol\top\3344a-tc-top03.dgn
 sisykes AT WZTC22410

APPROVED: 	DATE: 12/5/04	TEMPORARY PAVEMENT MARKING SCHEDULE							
	SCALE: NONE								
	DATE: SEP 04								
	DWG. BY: MHS								
	DESIGN BY: MHS								
REVIEWED BY: CLM		<table border="1"> <tr> <th colspan="2">REVISIONS</th> </tr> <tr> <td> </td> <td> </td> </tr> <tr> <td> </td> <td> </td> </tr> </table>		REVISIONS					
REVISIONS									
		<small>CADD FILE U3344A TC TCP3.DGN</small>							



PROJ. REFERENCE NO.	SHEET NO.
U-3344A	TCP-4A

PHASING

PHASE III CONTINUED

- STEP 4) USING ROADWAY STANDARD DRAWING 1101.02, SHEET 1 OF 7, AS NECESSARY, COMPLETE PROPOSED CULVERT AND CONSTRUCT PROPOSED PAVEMENT UP TO BUT NOT INCLUDING THE FINAL LAYER OF SURFACE COURSE AS SHOWN ON SHEET TCP-12B AND TCP-13.
- STEP 5) COMPLETE ALL WORK PREVIOUSLY BEGUN.
- STEP 6) INSTALL AS MUCH TEMPORARY (PAINT) PAVEMENT MARKINGS AND MARKERS IN THE FINAL 5-LANE, 2-WAY PATTERN AS POSSIBLE WITHOUT INTERFERING WITH EXISTING TRAFFIC. (SEE TCP-3 AND PM-2 THROUGH PM-4 FOR LAYOUT OF PAVEMENT MARKINGS).
- INSTALL AND COVER PERMANENT SIGNING. (SEE SIGNING PLANS)
- WORK IN A CONTINUOUS MANNER TO COMPLETE THE FOLLOWING WORK OF PHASE III, STEP 7.
- STEP 7) USING ROADWAY STANDARD DRAWING 1101.02, SHEET 1 OF 7 AND 4 OF 7, INSTALL THE REMAINING TEMPORARY PAVEMENT MARKINGS AND MARKERS IN THE FINAL PATTERN AND PLACE -L-, -Y2-, AND -Y3- TRAFFIC IN THE FINAL TRAFFIC PATTERN. (SEE TCP-3, AND PM-2 THROUGH PM-4).
- UNCOVER PERMANENT SIGNING.
- STEP 8) PERFORM MILLING AND PAVING BACK UP TO THE EXISTING PAVEMENT ELEVATION FROM -L- STA. 10+36 +/- TO STA. 13+50 +/- AND FROM -L- STA. 42+00 +/- TO STA. 46+33 +/- -L-. REPLACE TEMPORARY (PAINT) PAVEMENT MARKINGS AND MARKERS IN THE FINAL PATTERN.
- INSTALL PROPOSED LOOPS AND ACTIVATE FINAL SIGNAL (SEE SIGNAL PLANS).
- STEP 9) REMOVE THE TRAFFIC CONTROL DEVICES AND TEMPORARY PAVEMENT MARKINGS PREVIOUSLY INSTALLED PER SHEET TCP-8A AND INSTALL FINAL PAVEMENT MARKINGS AND MARKERS ON THIS SECTION OF AIRPORT BLVD. TO RETURN IT TO THE EXISTING 5-LANE, 2-WAY TRAFFIC PATTERN (SEE PM-5).
- STEP 10) USING ROADWAY STANDARD DRAWING 1101.02, SHEET 4 OF 7, PLACE THE FINAL LAYER OF SURFACE COURSE AND INSTALL THE FINAL PAVEMENT MARKINGS AND MARKERS ON ALL ROADS. (SEE PM-1 THROUGH PM-4).
- STEP 11) REMOVE ALL WORK ZONE TRAFFIC CONTROL DEVICES.

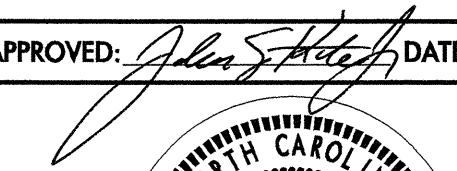
19-JAN-2005 13:55
 \\ets-ccf501\U3344A\TCP\U3344A-TC-TCP04A.dgn
 msfeelman AT TELC2231

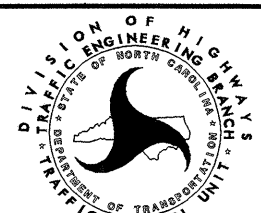
APPROVED:  DATE: 11/2/05 	<h2 style="margin: 0;">PHASING</h2>	<table border="1" style="width: 100%; border-collapse: collapse;"> <tr> <th colspan="2" style="text-align: left;">REVISIONS</th> </tr> <tr> <td style="width: 50%;"> </td> <td style="width: 50%;"> </td> </tr> <tr> <td> </td> <td> </td> </tr> <tr> <td> </td> <td> </td> </tr> </table>	REVISIONS							
REVISIONS										
<table border="1" style="width: 100%; border-collapse: collapse;"> <tr> <td>SCALE: NONE</td> </tr> <tr> <td>DATE: SEP 04</td> </tr> <tr> <td>DWG. BY: MHS</td> </tr> <tr> <td>DESIGN BY: MHS</td> </tr> <tr> <td>REVIEWED BY: CLM</td> </tr> </table>	SCALE: NONE	DATE: SEP 04	DWG. BY: MHS	DESIGN BY: MHS	REVIEWED BY: CLM		<table border="1" style="width: 100%; border-collapse: collapse;"> <tr> <td style="font-size: 8px;">CADD FILE</td> <td style="font-size: 8px;">U3344A TC TCP4.DGN</td> </tr> </table>	CADD FILE	U3344A TC TCP4.DGN	
SCALE: NONE										
DATE: SEP 04										
DWG. BY: MHS										
DESIGN BY: MHS										
REVIEWED BY: CLM										
CADD FILE	U3344A TC TCP4.DGN									

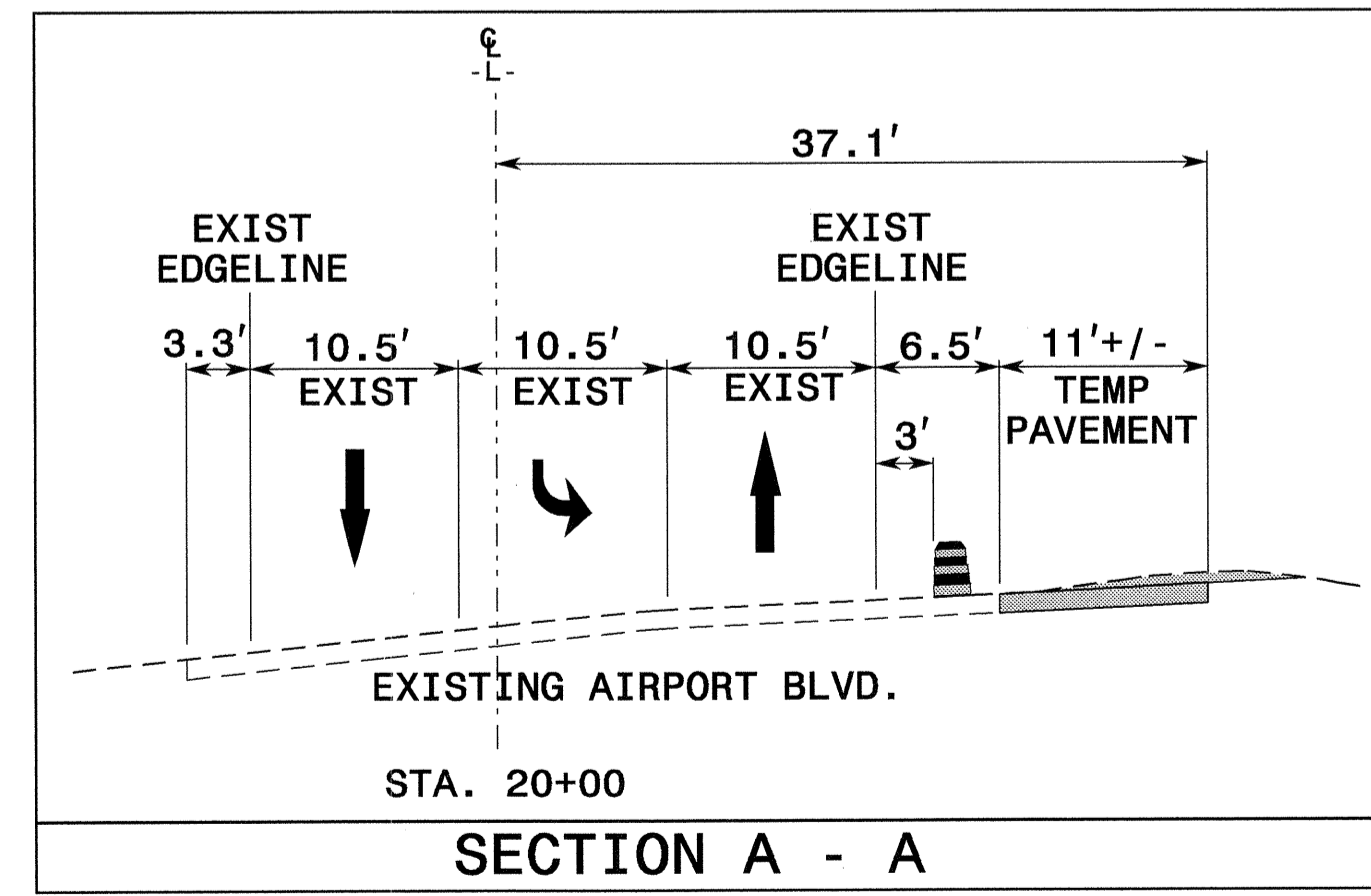
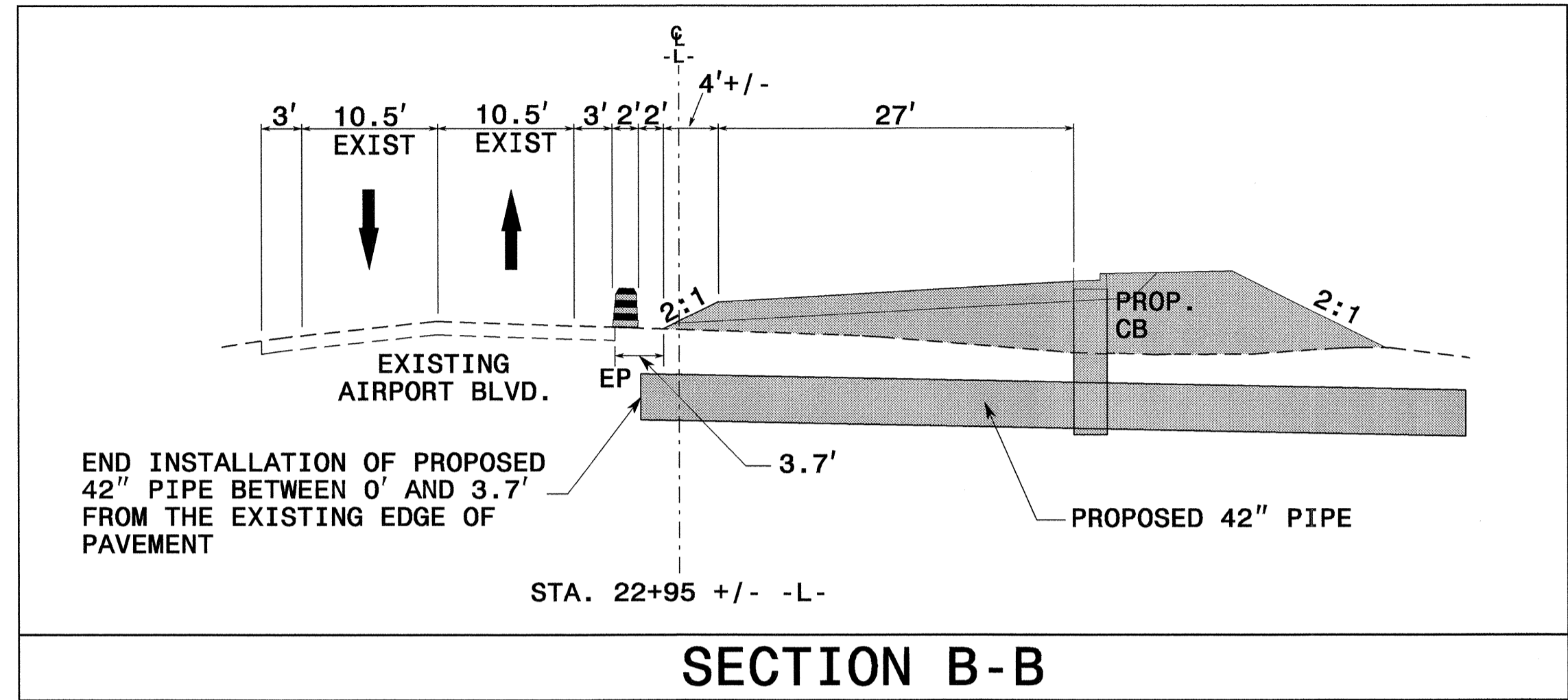
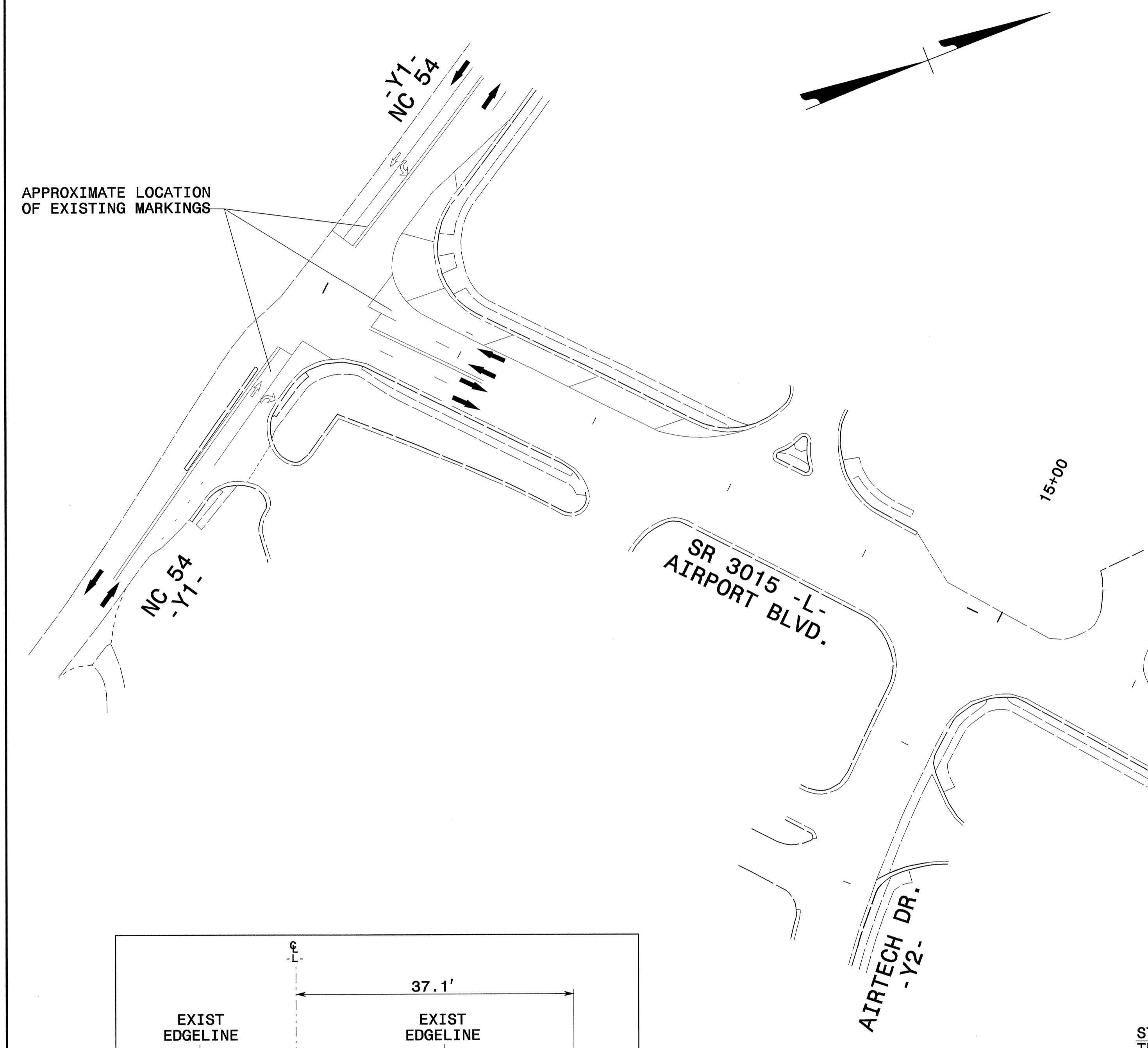

TEMPORARY PAVEMENT OFFSETS

STATION	OFFSET FROM -L- CENTERLINE
19+00	49.6' RIGHT
19+50	38.1' RIGHT
20+00	37.1' RIGHT
20+50	35.4' RIGHT
21+00	33.9' RIGHT
21+50	32.4' RIGHT

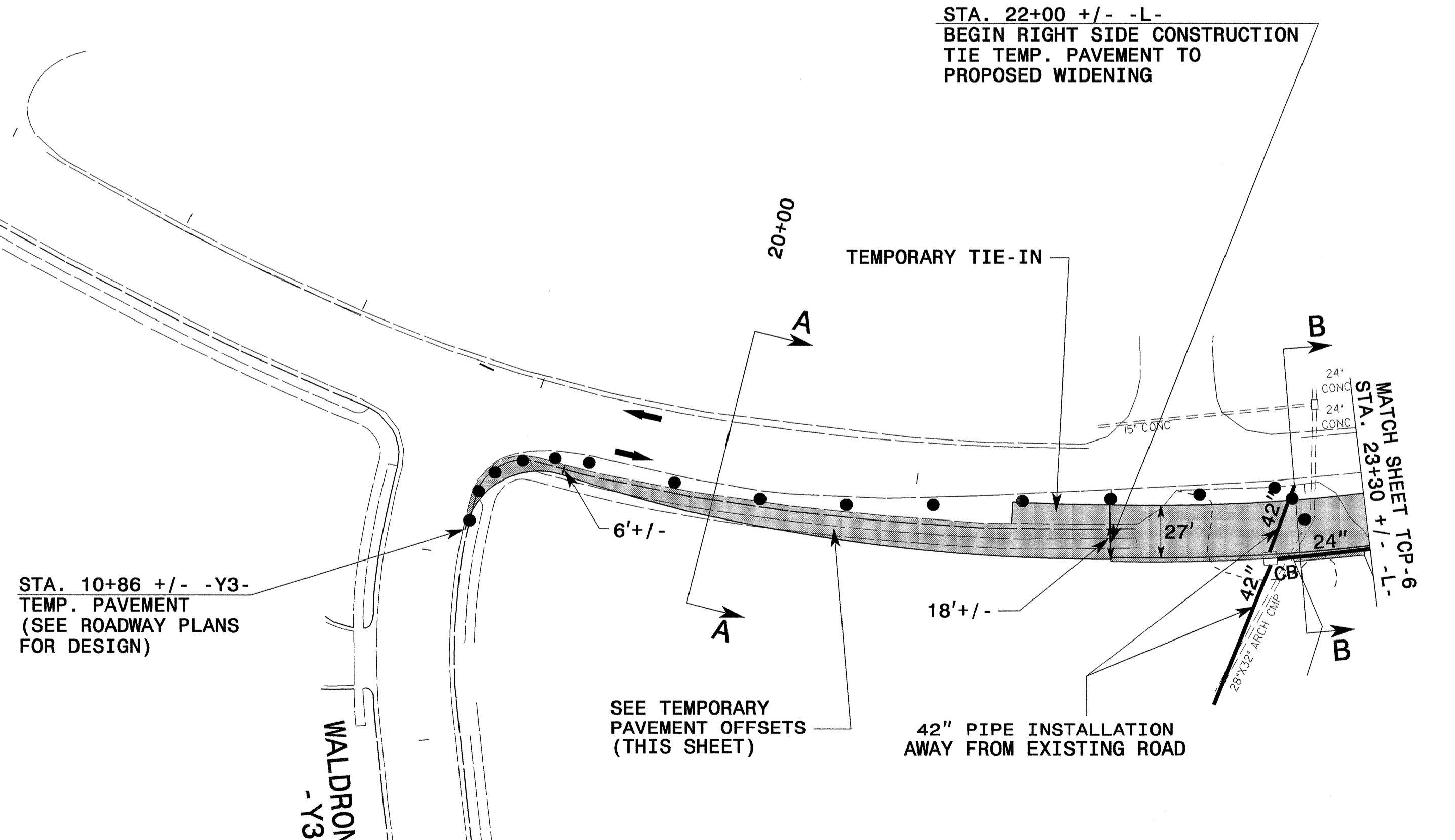

19-JAN-2005 13:55
 \\ets-cctfso01\U33444g8\TCP\U3344A-TC-TCP05.dgn
 mstfeilmon AT TETC212231

APPROVED:	DATE: 12/1/05	PHASE I	
	SCALE: NONE		REVISIONS
	DATE: 12-04		
	DWG. BY: MHS		
	DESIGN BY: MHS		
	REVIEWED BY: CLM		CADD FILE

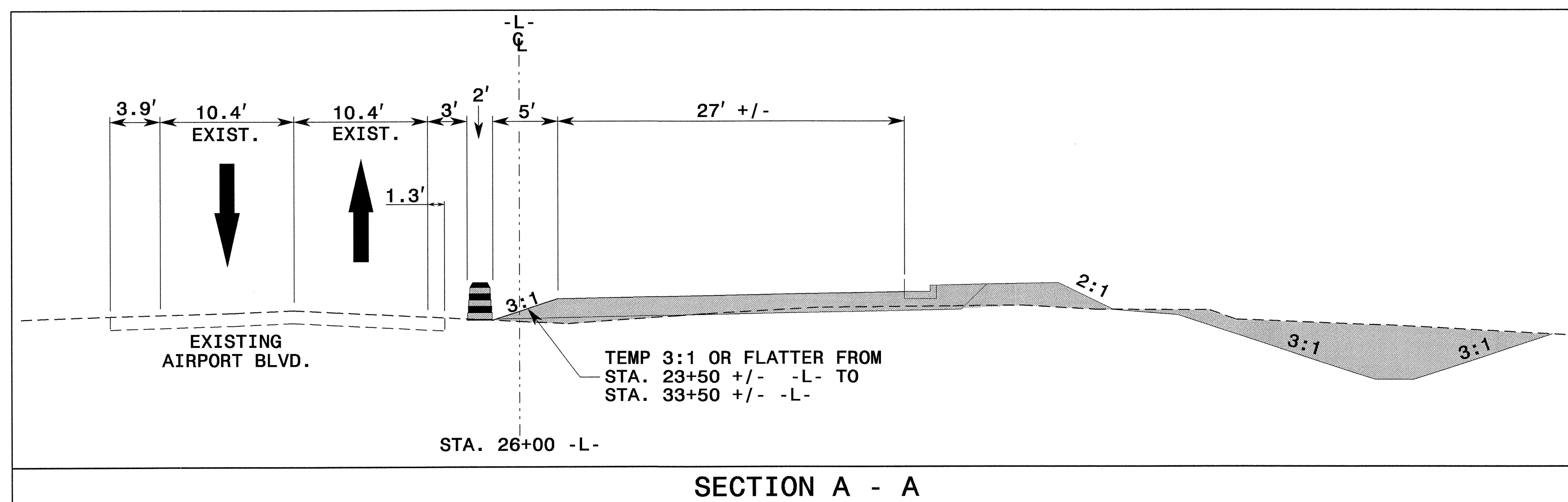
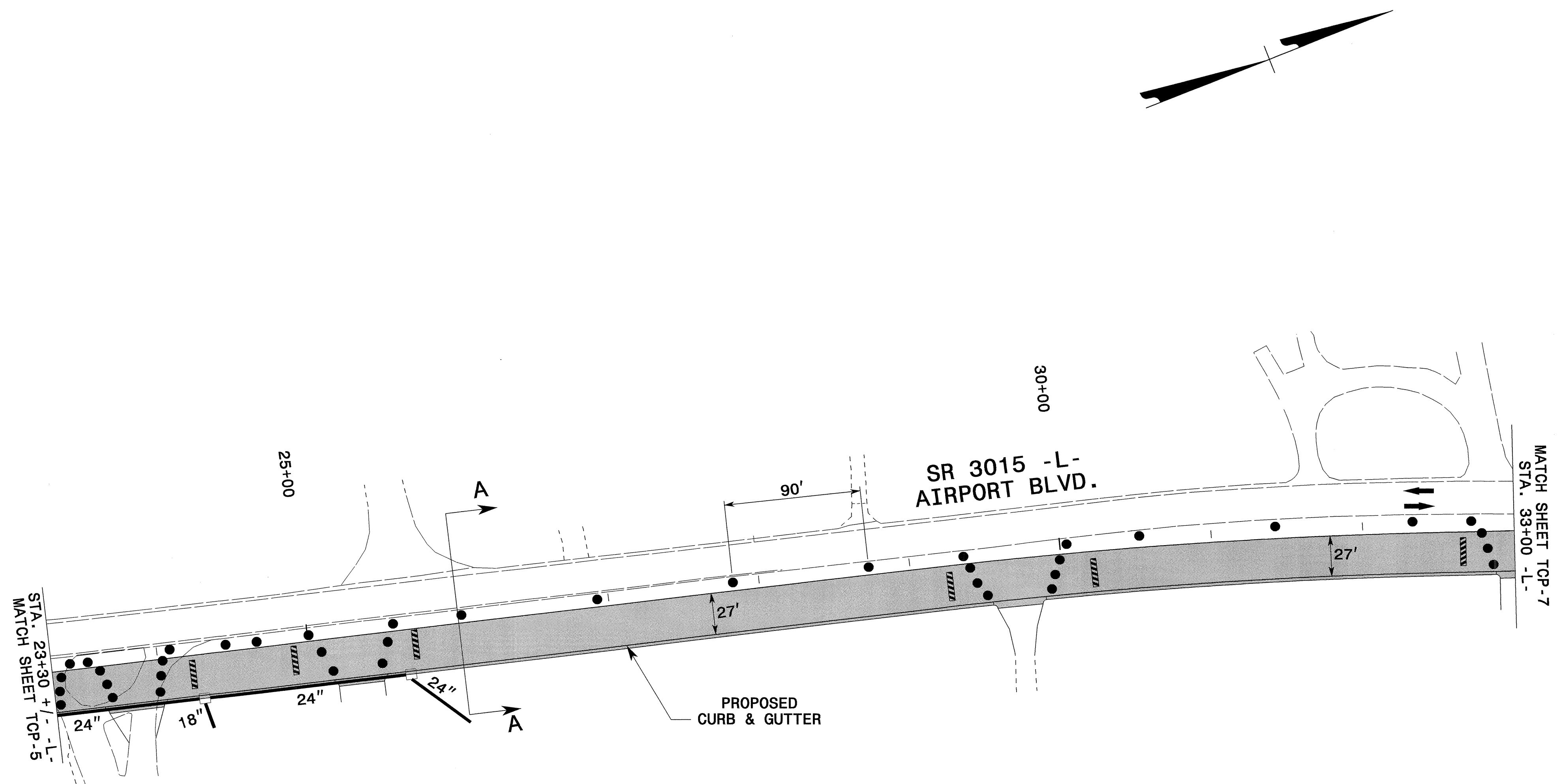

APPROVED: *John S. Kite, Jr.* DATE: *11/15/04*

SEAL
 NORTH CAROLINA
 PROFESSIONAL
 SEAL
 022104
 ENGINEER
 JOHN S. KITE, JR.

PHASE I		REVISIONS	
SCALE:	NONE		
DATE:	9-04		
DWG. BY:	MHS		
DESIGN BY:	MHS		
REVIEWED BY:	CLM		
		CADD FILE	

19-JAN-2005 13:55
 \\efs-ccfso1\U3344a\TCP\U3344A-TC-TCP06.dgn
 msfeelman AT 11/15/04

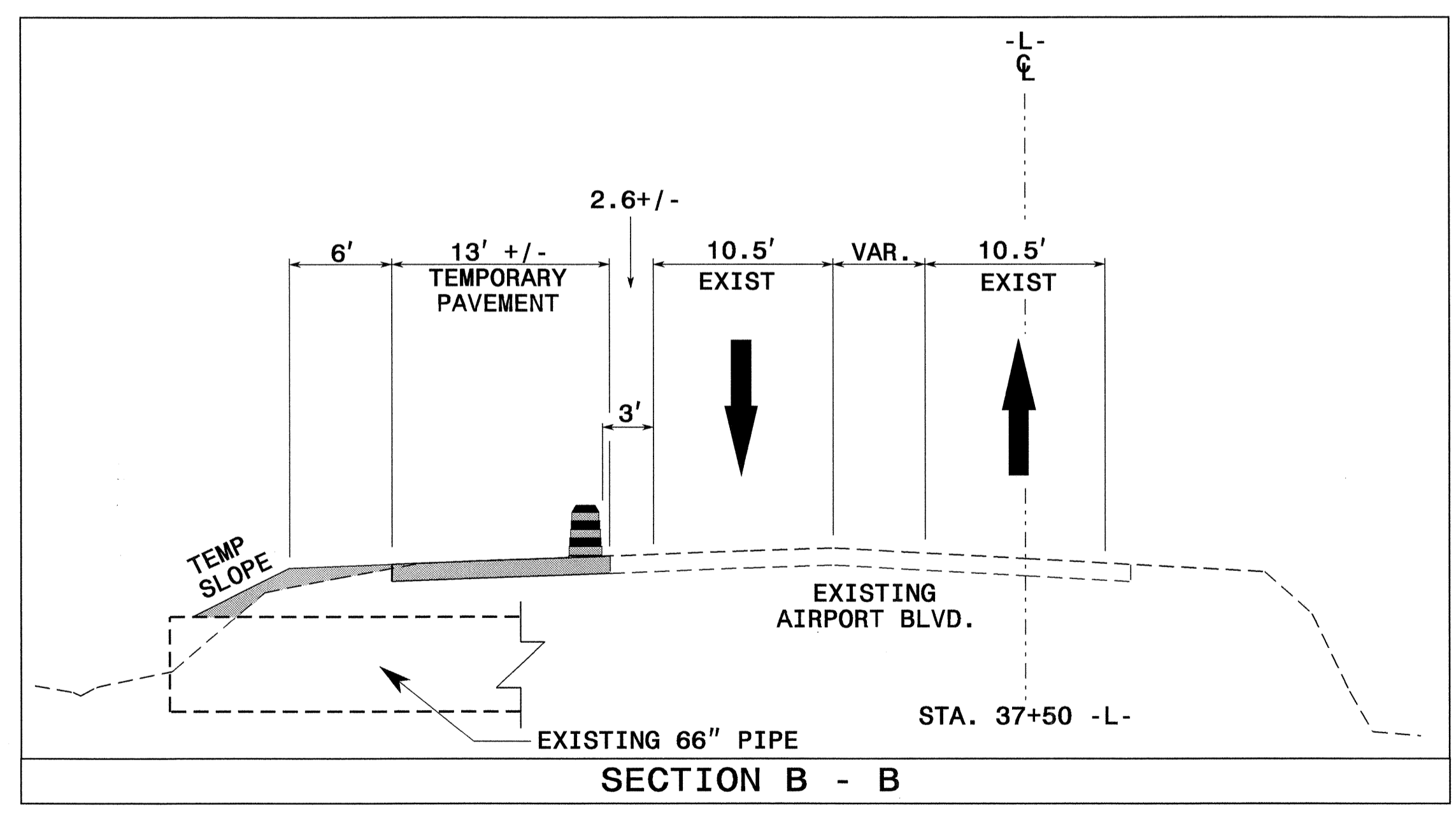
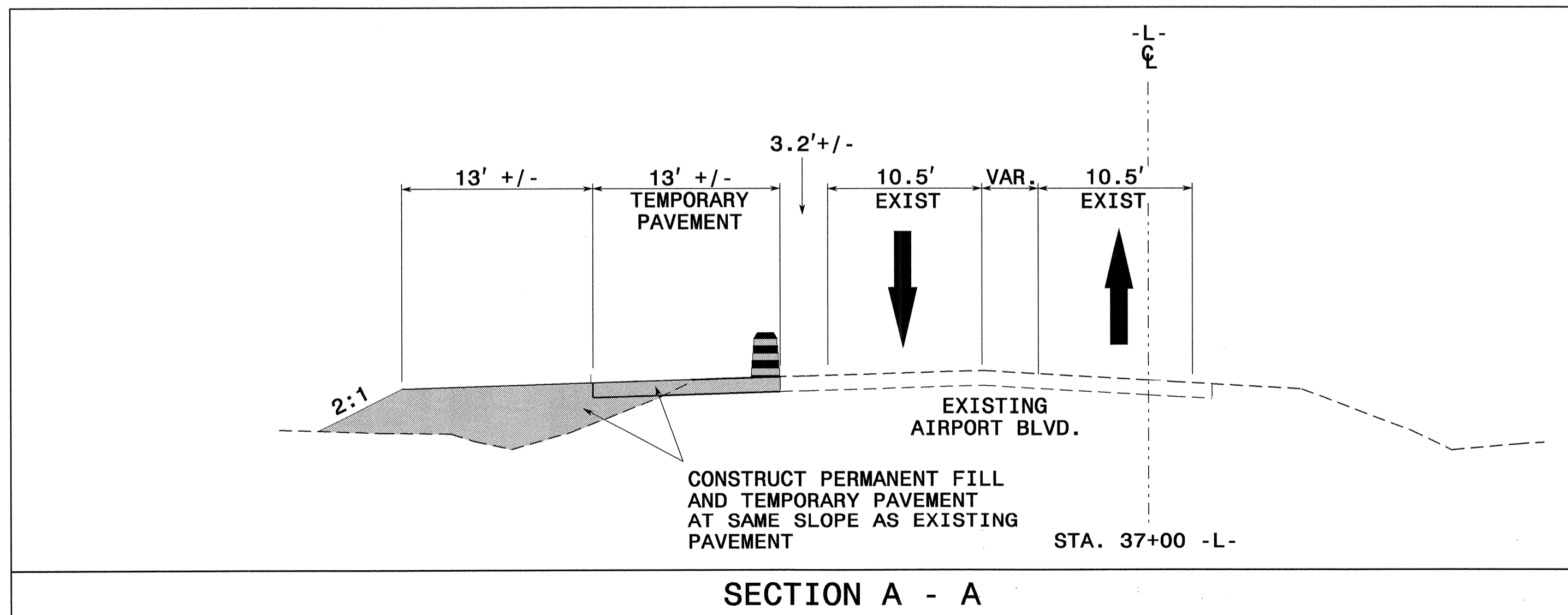
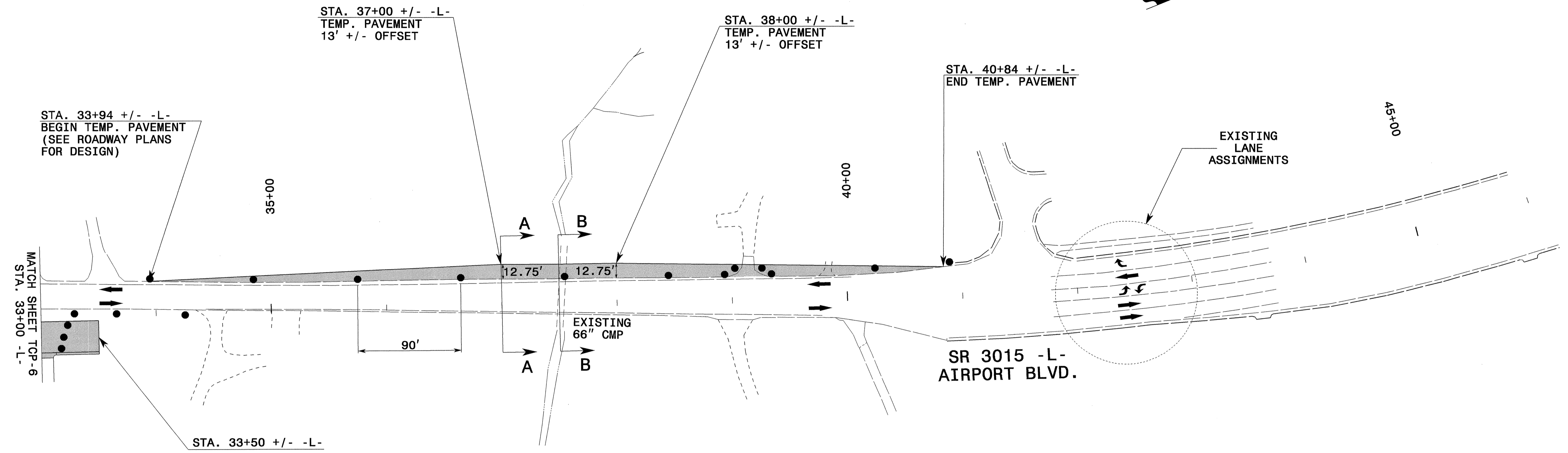

APPROVED: *John S. Kite* DATE: 12/10/05

SEAL
 NORTH CAROLINA
 PROFESSIONAL
 ENGINEER
 JOHN S. KITE
 022104

PHASE I

SCALE: NONE		REVISIONS
DATE: 10-04		
DESIGN BY: MHS		
REVIEWED BY: CLM		

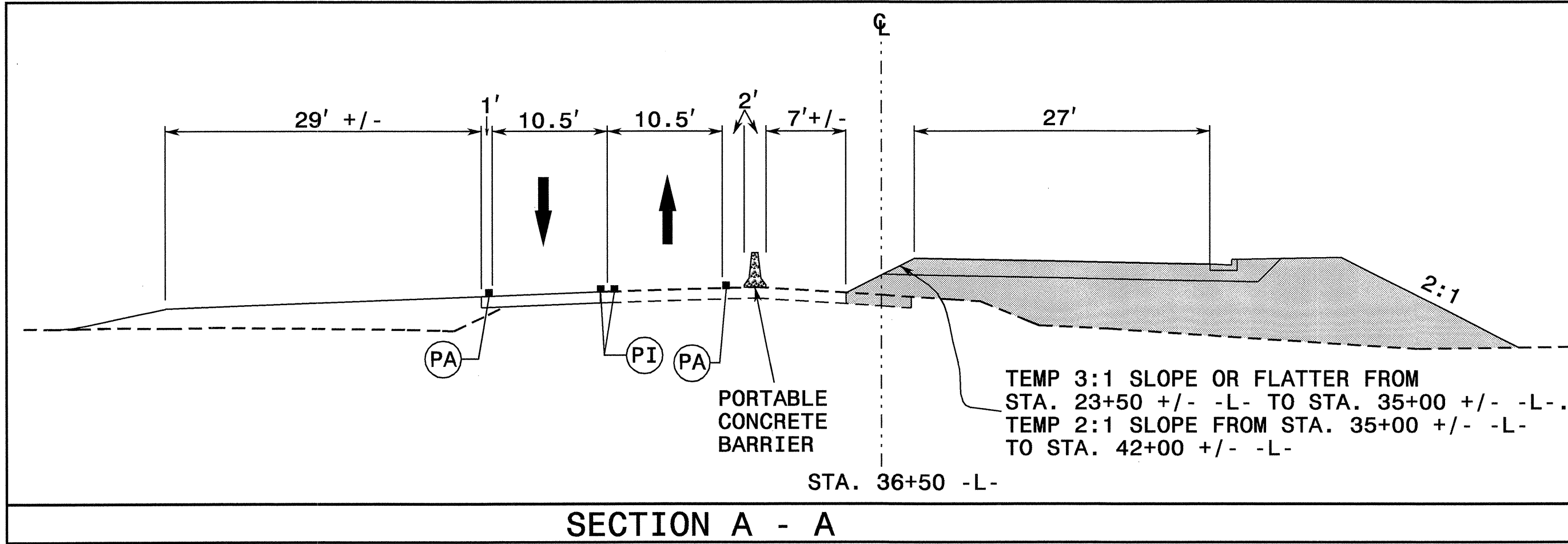
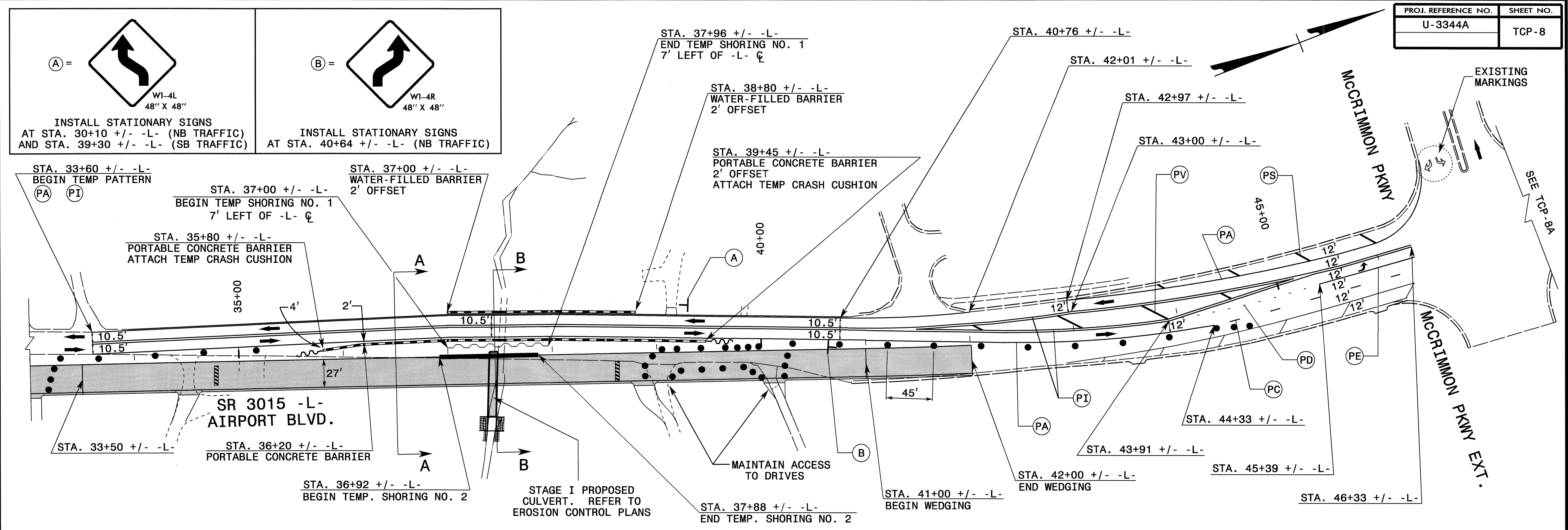

TEMPORARY SHORING NO. 1

ESTIMATED QUANTITY = 960 SQUARE FEET BASED ON AN AVERAGE ESTIMATE HEIGHT OF 10.0 FEET.

- DO NOT USE STANDARD TEMPORARY SHORING FROM STATION 37+00, 7 FT. LT, TO STATION 37+96, 7 FT. LT.
- WHEN USING CONTRACTOR DESIGNED SHORING FROM STATION 37+00, 7 FT LT, TO STATION 37+96, 7 FT LT, USE THE FOLLOWING SOIL PARAMETERS: UNIT WEIGHT OF SOIL ABOVE WATER TABLE, $\gamma = 120\text{PCF}$ COHESION, $c = 0\text{ PSF}$
UNIT WEIGHT OF SOIL BELOW WATER TABLE, $\gamma = 60\text{PCF}$
- DRIVEN PILING FOR TEMPORARY SHORING FROM STATION 37+00, 7 FT LT, TO STATION 37+96, 7 FT LT, MAY NOT PENETRATE BELOW ELEVATION 309 FT DUE TO THE PRESENCE OF AN OBSTRUCTION, VERY DENSE OR HARD SOIL, WEATHERED OR HARD ROCK.
- FOR CONTRACTOR DESIGNED SHORING, SURVEY THE SHORING LOCATION TO DETERMINE EXISTING ELEVATIONS AND ACTUAL DESIGN HEIGHTS BEFORE BEGINNING DESIGN.
- CONTRACTOR DESIGNED SHORING FROM STATION 37+00, 7 FT LT, TO STATION 37+96, 7 FT LT, SHALL MAINTAIN FLOW IN THE EXISTING PIPE.

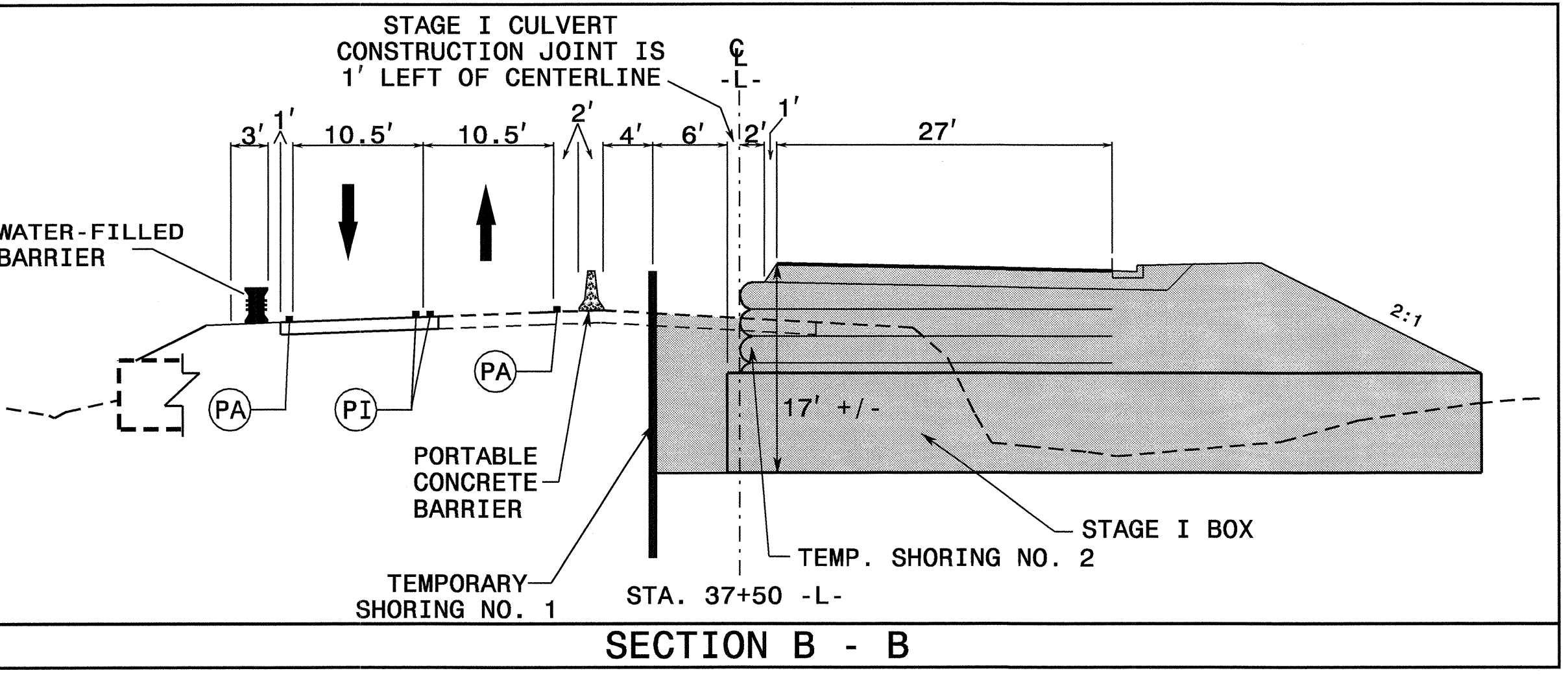

TEMPORARY SHORING NO. 2

ESTIMATED QUANTITY = 970 SQUARE FEET BASED ON AN AVERAGE ESTIMATE HEIGHT OF 10.1 FEET.

- DO NOT USE STANDARD TEMPORARY SHORING FROM STATION 36+92, 4 FT RT, TO STATION 37+96, 4 FT RT.
- WHEN USING CONTRACTOR DESIGNED SHORING FROM STATION 36+92, 4 FT RT, TO STATION 37+96, 4 FT RT, USE THE FOLLOWING SOIL PARAMETERS: UNIT WEIGHT OF SOIL ABOVE WATER TABLE, $\gamma = 120\text{PCF}$ COHESION, $c = 0\text{ PSF}$
UNIT WEIGHT OF SOIL BELOW WATER TABLE, $\gamma = 60\text{PCF}$
- DRIVEN PILING FOR TEMPORARY SHORING FROM STATION 36+92, 4 FT RT, TO STATION 37+96, 4 FT RT, MAY NOT PENETRATE BELOW ELEVATION 309 FT DUE TO THE PRESENCE OF AN OBSTRUCTION, VERY DENSE OR HARD SOIL, WEATHERED OR HARD ROCK.
- FOR CONTRACTOR DESIGNED SHORING, SURVEY THE SHORING LOCATION TO DETERMINE EXISTING ELEVATIONS AND ACTUAL DESIGN HEIGHTS BEFORE BEGINNING DESIGN.

ALL PAVEMENT MARKING SYMBOLS ARE PAINT

APPROVED: *[Signature]* DATE: 10/10/04

SEAL:

PHASE I

SCALE: NONE		REVISIONS
DATE: 10-04		
DWG. BY: MHS		
DESIGN BY: MHS		
REVIEWED BY: CLM	CADD FILE	

08-JAN-2007 11:59 \\dot\dfs\o\070\proj\top\projects-u\3344a\traffic\tr\officecontrol\top\3344a.tc_top08.dgn AT WZTC22101 sisykes

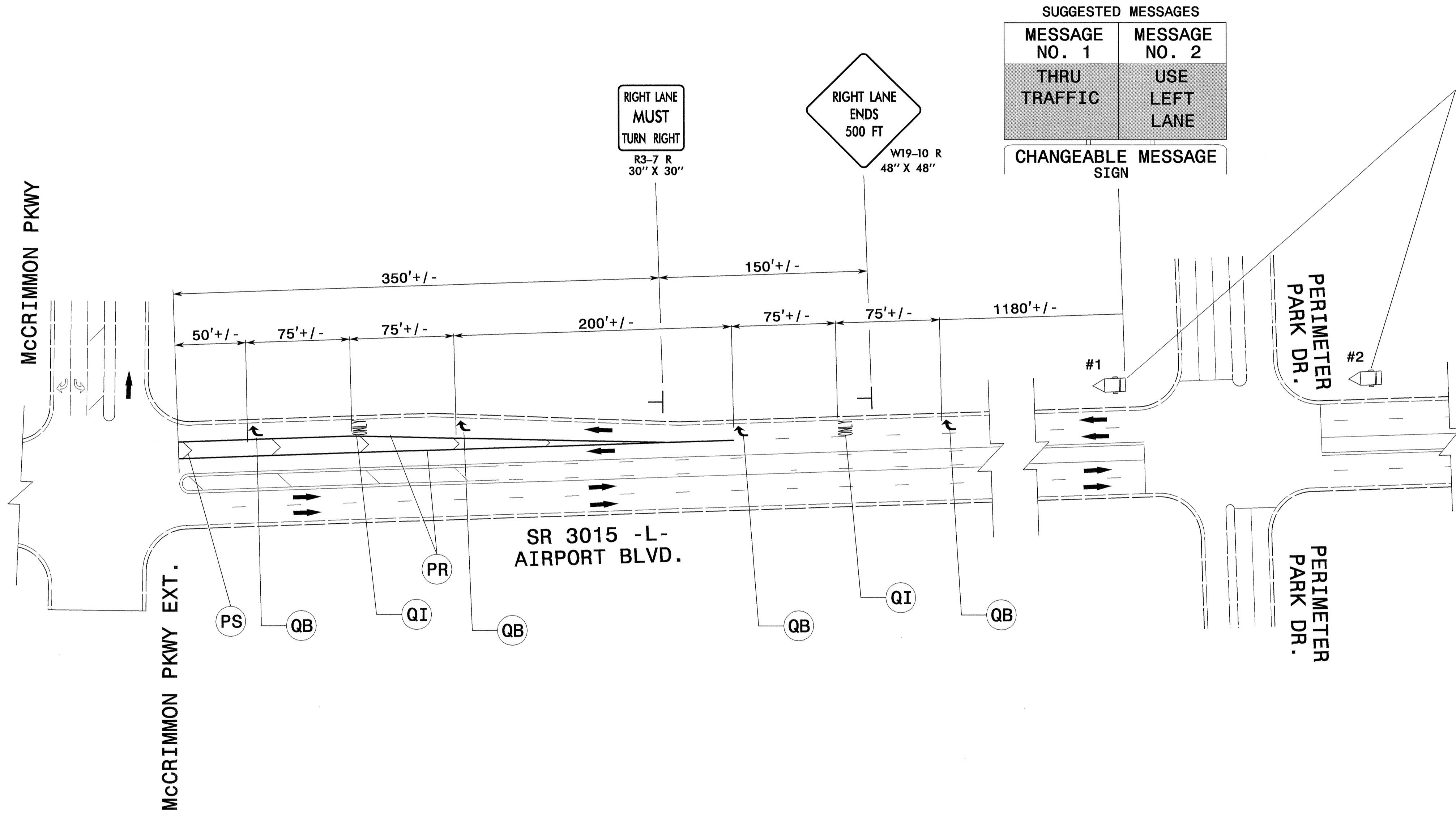
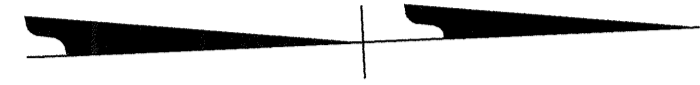

SUGGESTED MESSAGES

MESSAGE NO. 1	MESSAGE NO. 2
THRU TRAFFIC	USE LEFT LANE

CHANGEABLE MESSAGE SIGN

RELOCATE CMS FROM LOCATION #1 TO LOCATION #2 DURING WEEKEND ROAD CLOSURE. NOTE MESSAGES WILL CHANGE DURING ROAD CLOSURE. SEE TCP-14

19-JAN-2005 13:55
 \\efs-cctf\01\U3344a\TCP\U3344A_TC_TCP08A.dgn
 msteelmon AT TEL212231

APPROVED: <i>[Signature]</i> DATE: 11/10/05	PHASE I	
	SCALE: NONE	
	DATE: 10-04	
	DWG. BY: MHS	
	DESIGN BY: MHS	
REVIEWED BY: CLM	REVISIONS	

SUGGESTED MESSAGES	
MESSAGE NO. 1	MESSAGE NO. 2
NEW TRAFFIC PATTERN	ON AIRPORT BLVD
CHANGEABLE MESSAGE SIGN	

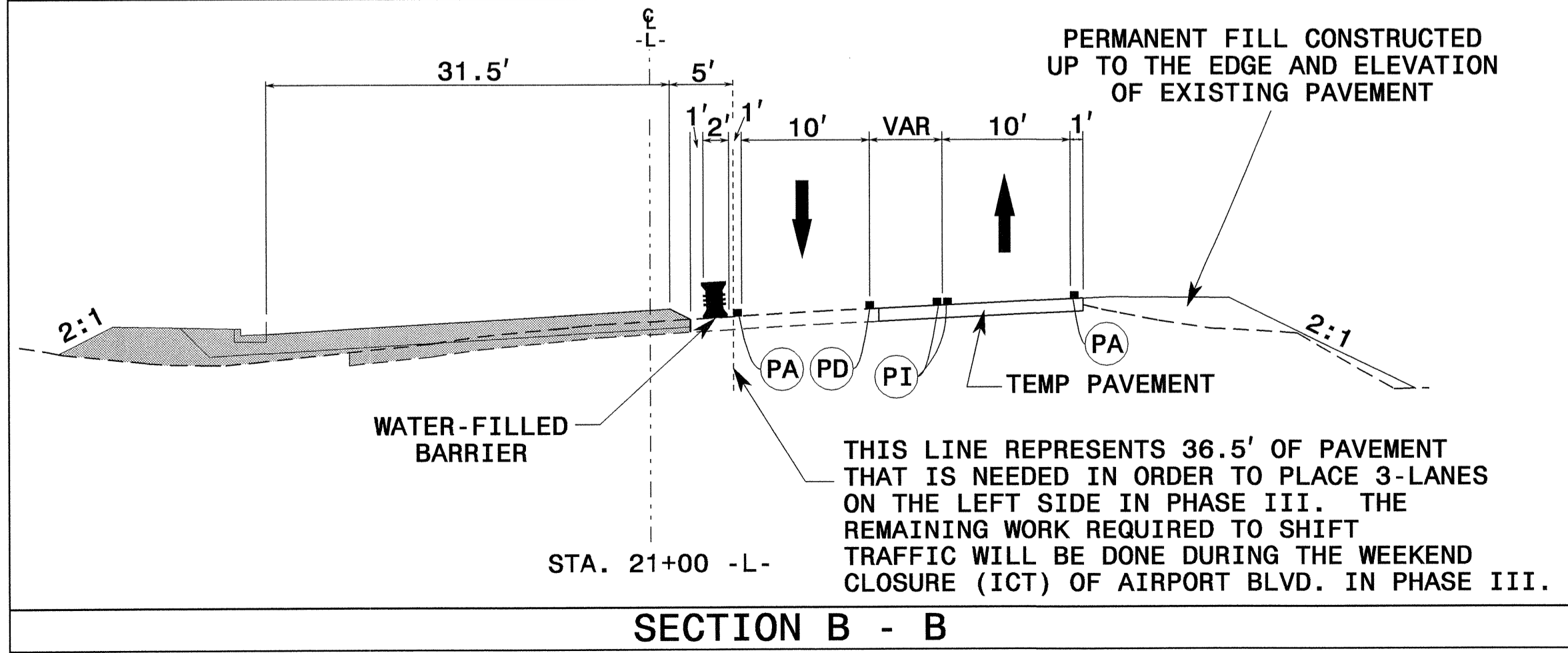
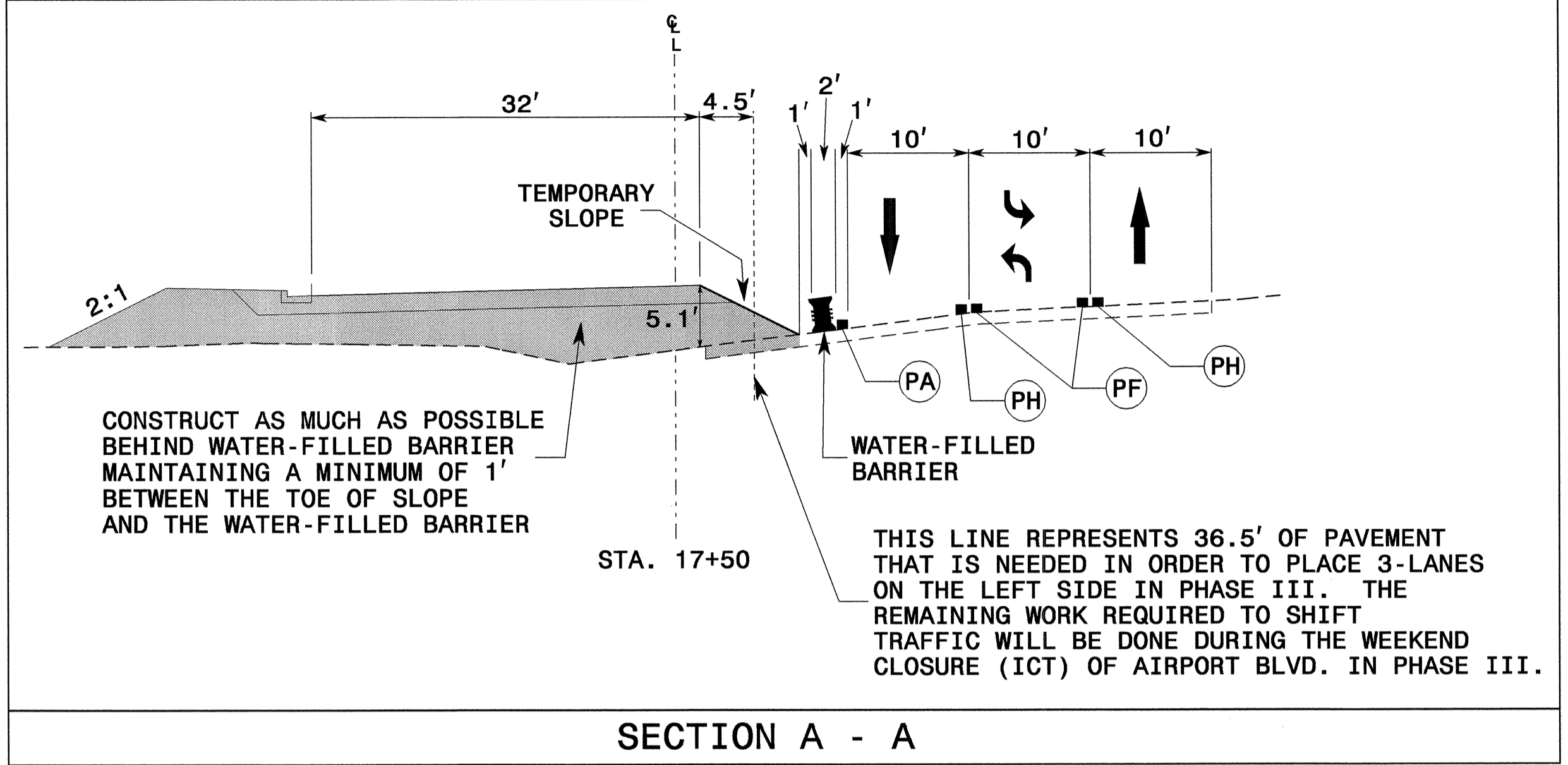
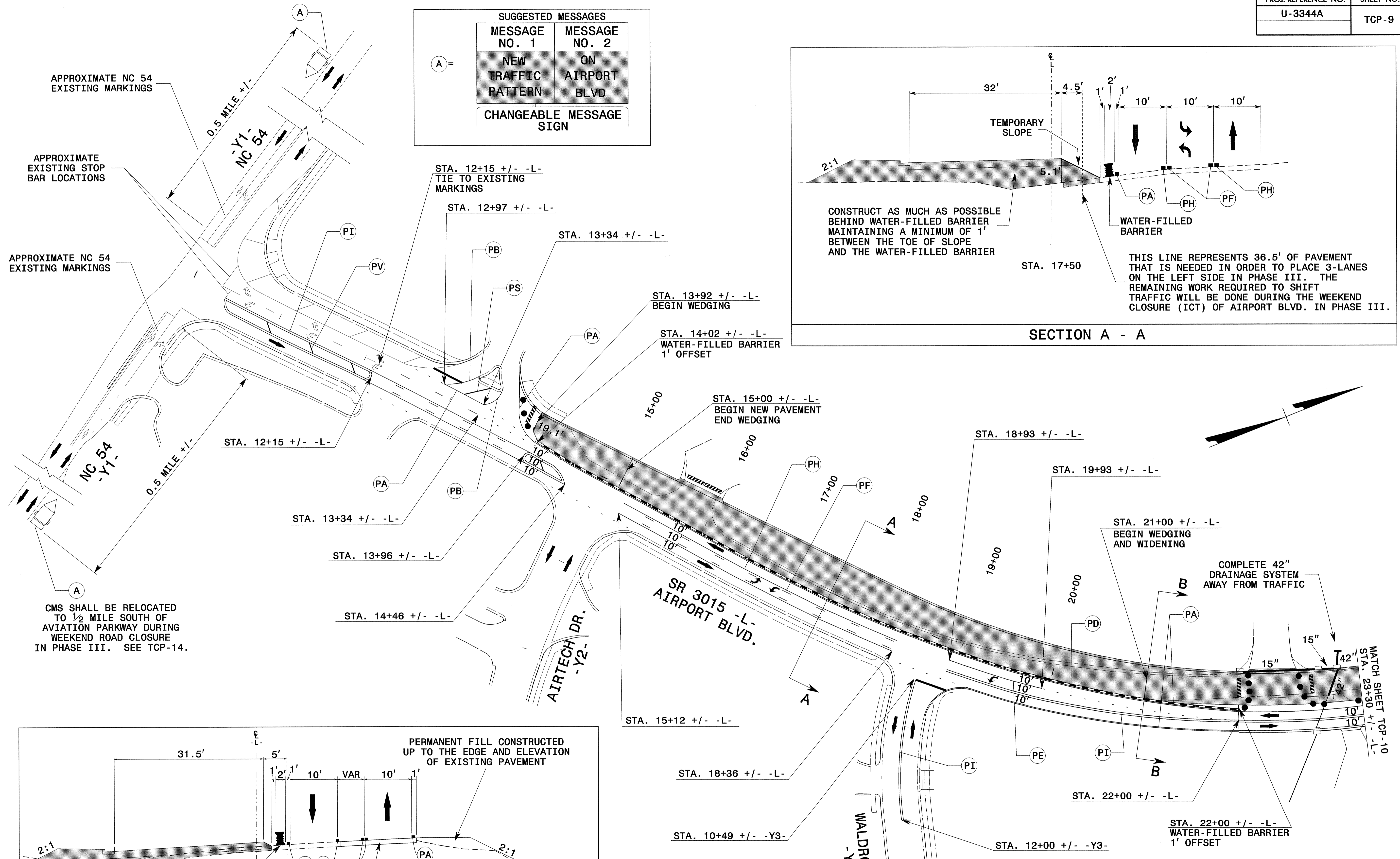

APPROXIMATE NC 54 EXISTING MARKINGS

APPROXIMATE EXISTING STOP BAR LOCATIONS

APPROXIMATE NC 54 EXISTING MARKINGS

APPROXIMATE NC 54 EXISTING MARKINGS

CMS SHALL BE RELOCATED TO 1/2 MILE SOUTH OF AVIATION PARKWAY DURING WEEKEND ROAD CLOSURE IN PHASE III. SEE TCP-14.

ALL PAVEMENT MARKING SYMBOLS ARE PAINT

APPROVED: *[Signature]* DATE: 12/05

SEAL

PROFESSIONAL ENGINEER
SEAL 022104
ENGINEER
JOHN S. KITE, JR.
STATE OF NORTH CAROLINA

PHASE II

SCALE: NONE		REVISIONS
DATE: 12-04		
DESIGN BY: MHS		
REVIEWED BY: CLM		

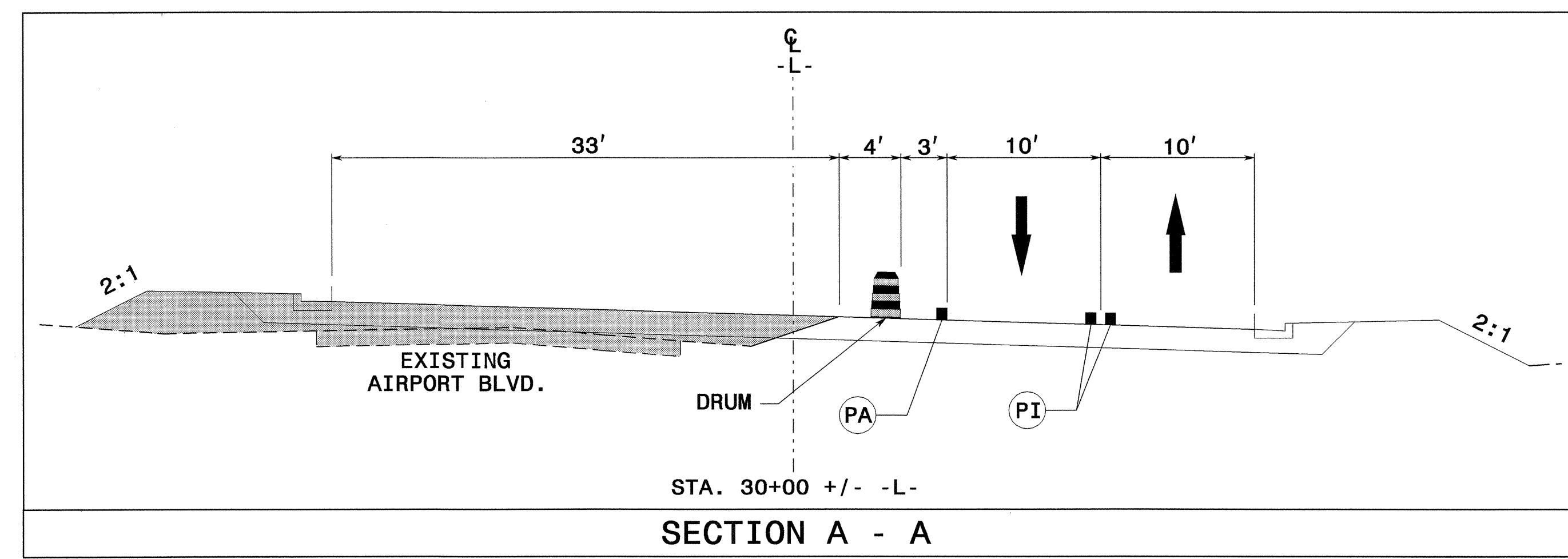
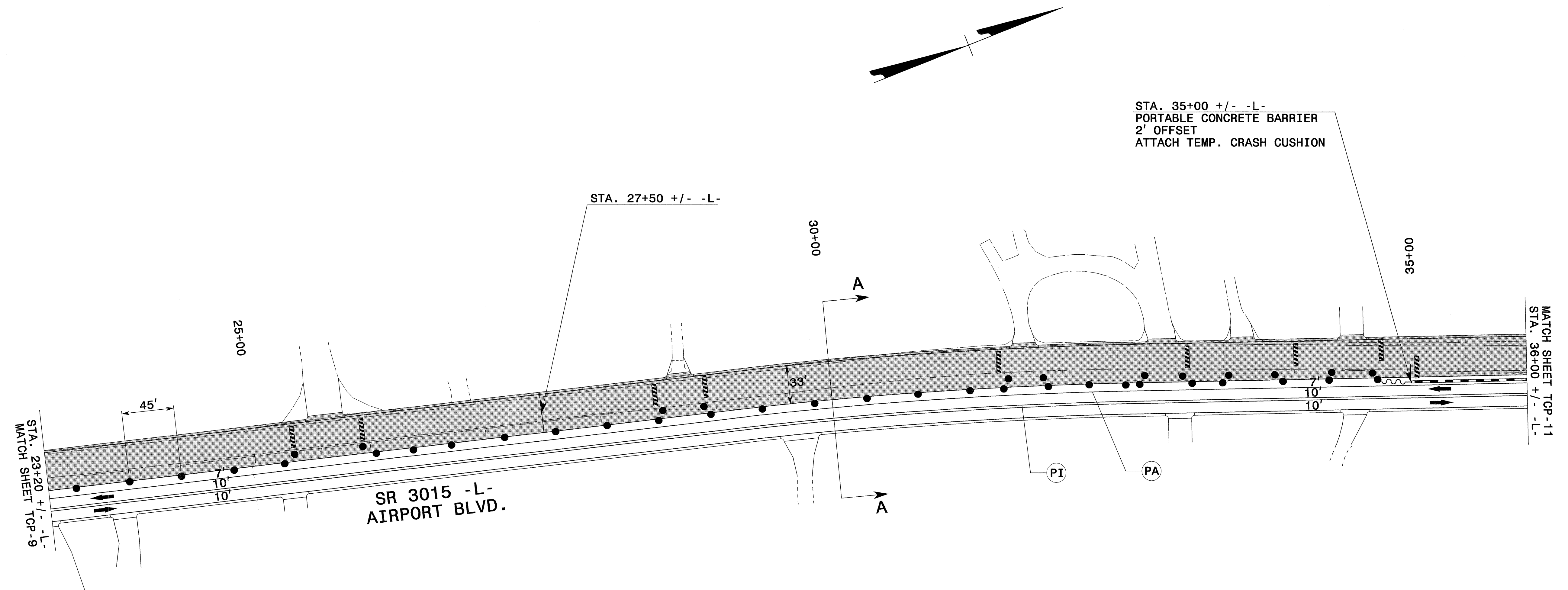

19-JAN-2005 13:57
 \\ets-cctfso1\U3344a\TCP\U3344A-TC-TCP10.dgn
 msf@elman AT TETC21231

APPROVED: <i>[Signature]</i> DATE: 10/05	PHASE II	
SEAL 	SCALE: NONE	
	DATE: 10-04	
	DWG. BY: MHS	
	DESIGN BY: MHS	
REVIEWED BY: CLM	REVISIONS	

WEEKEND ROAD CLOSURE

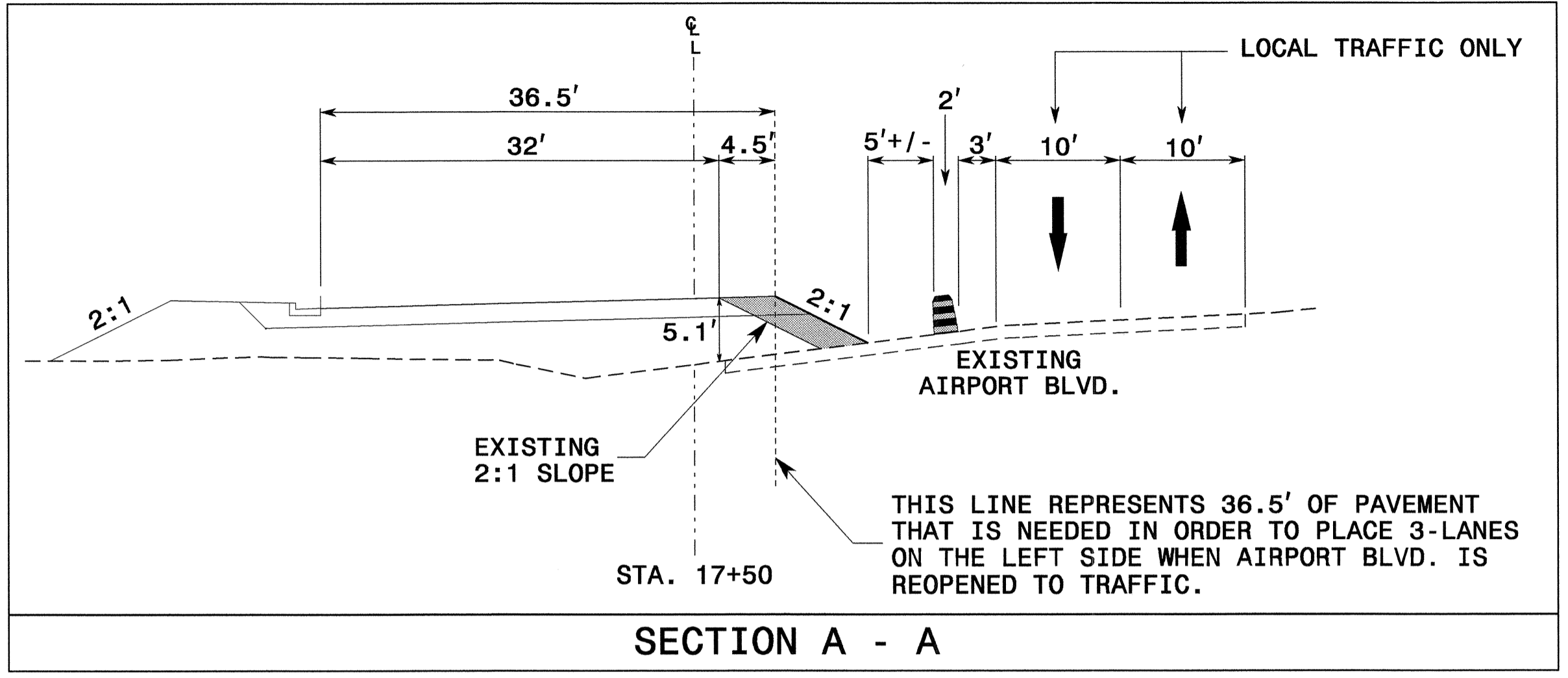
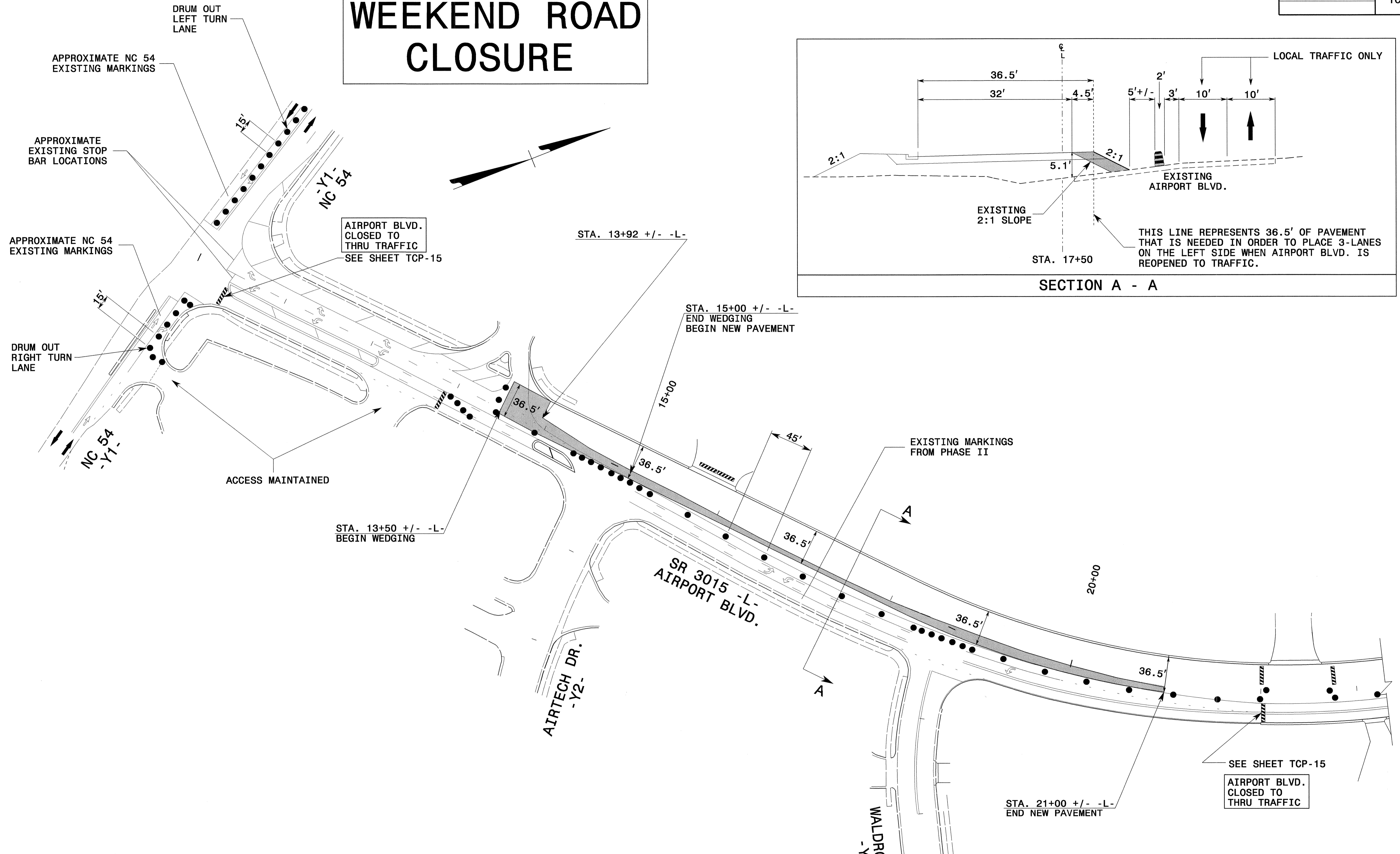

USE FLAGGERS OR POLICE TO MAINTAIN LOCAL TRAFFIC

SEE SHEETS TCP-15 AND TCP-15A FOR OFFSITE DETOUR AND TYPE III BARRICADE LOCATIONS

APPROVED: *John S. Vite Jr.* DATE: 11/1/05

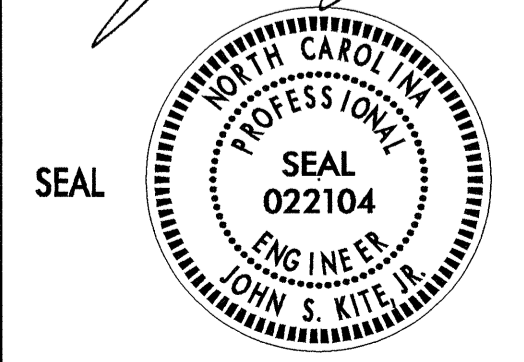

PHASE III

SCALE: NONE		REVISIONS
DATE: 12-04		
DWG. BY: MHS		
DESIGN BY: MHS		
REVIEWED BY: CLM		

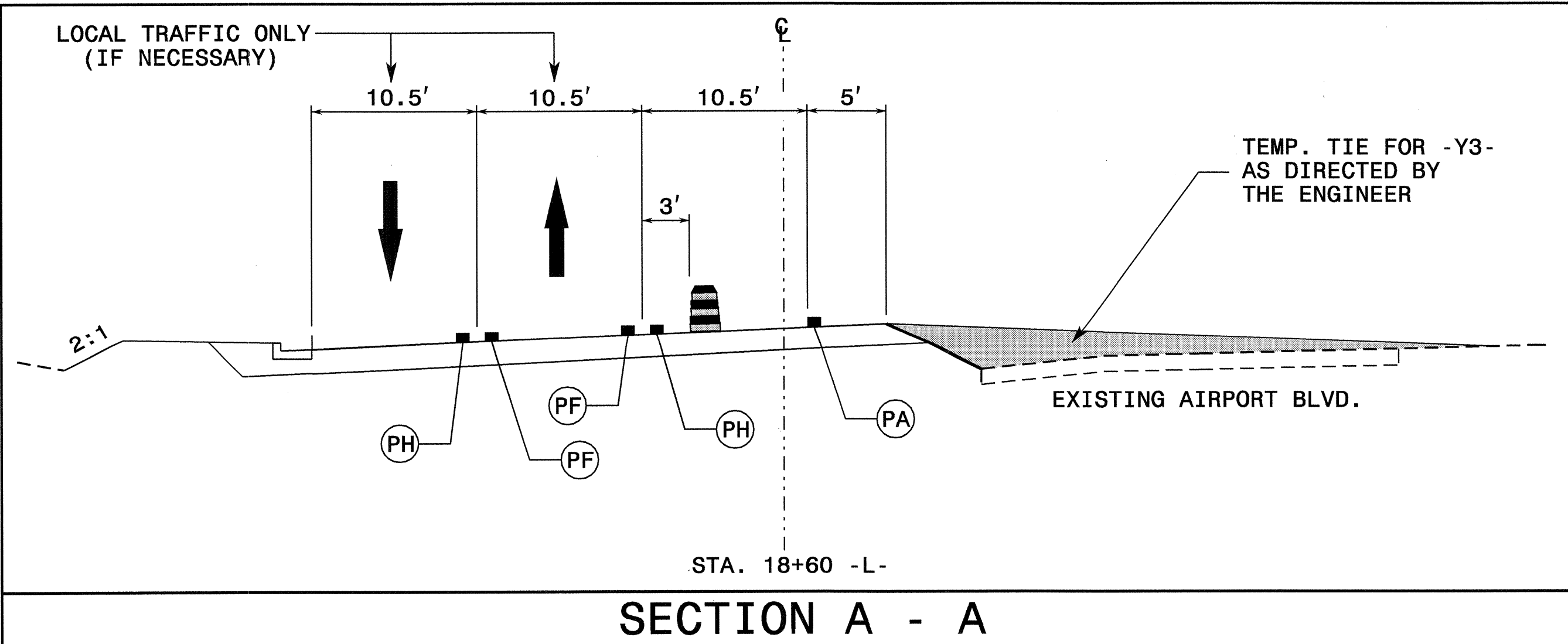
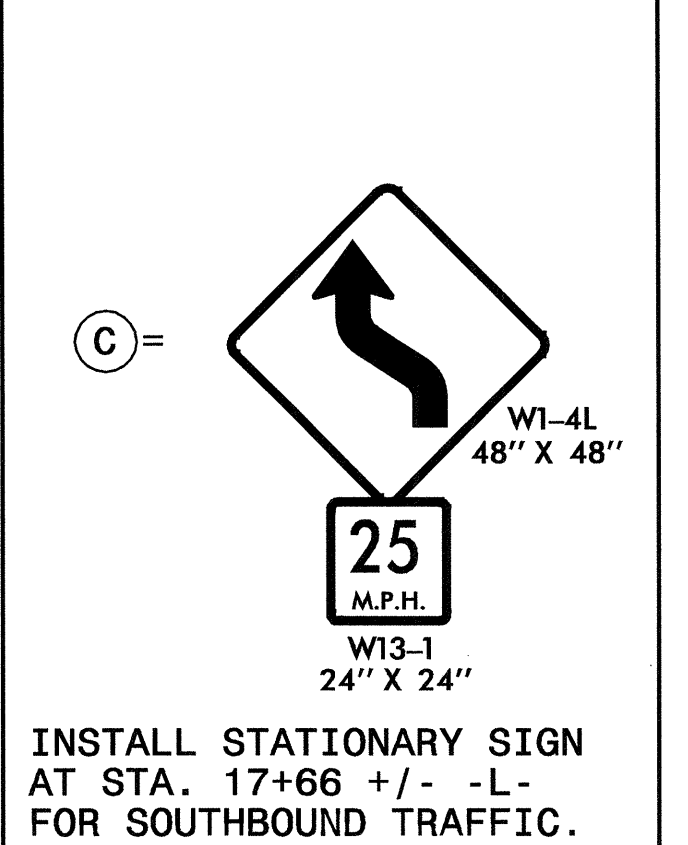
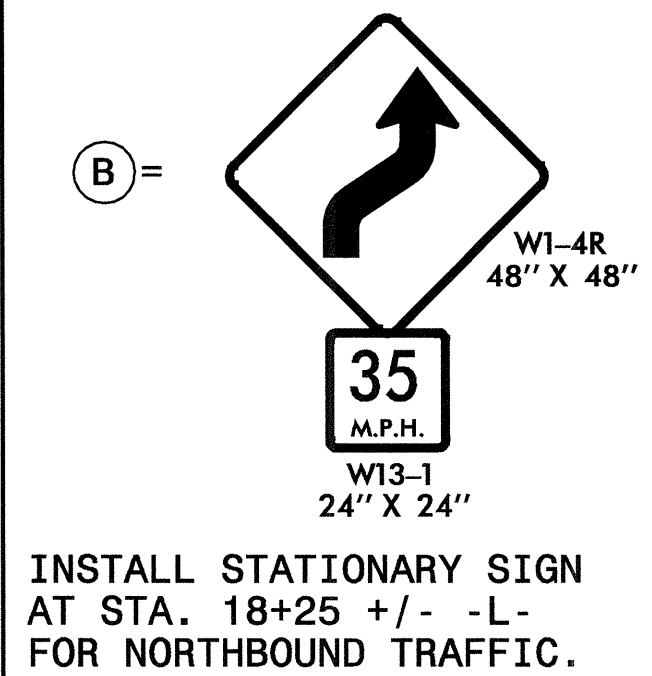
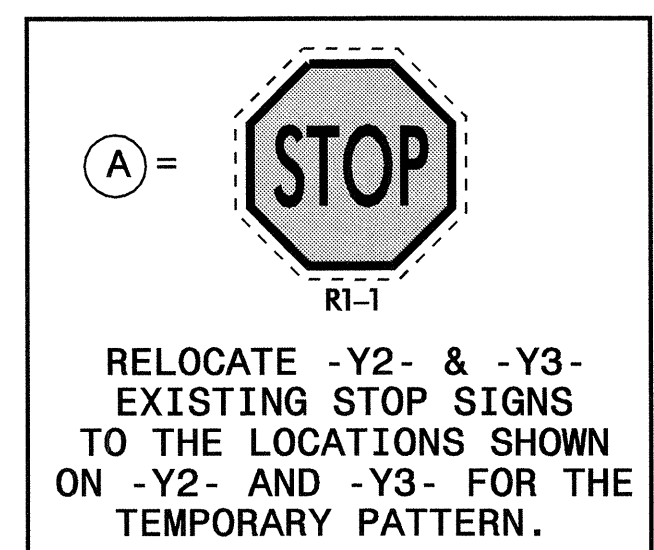
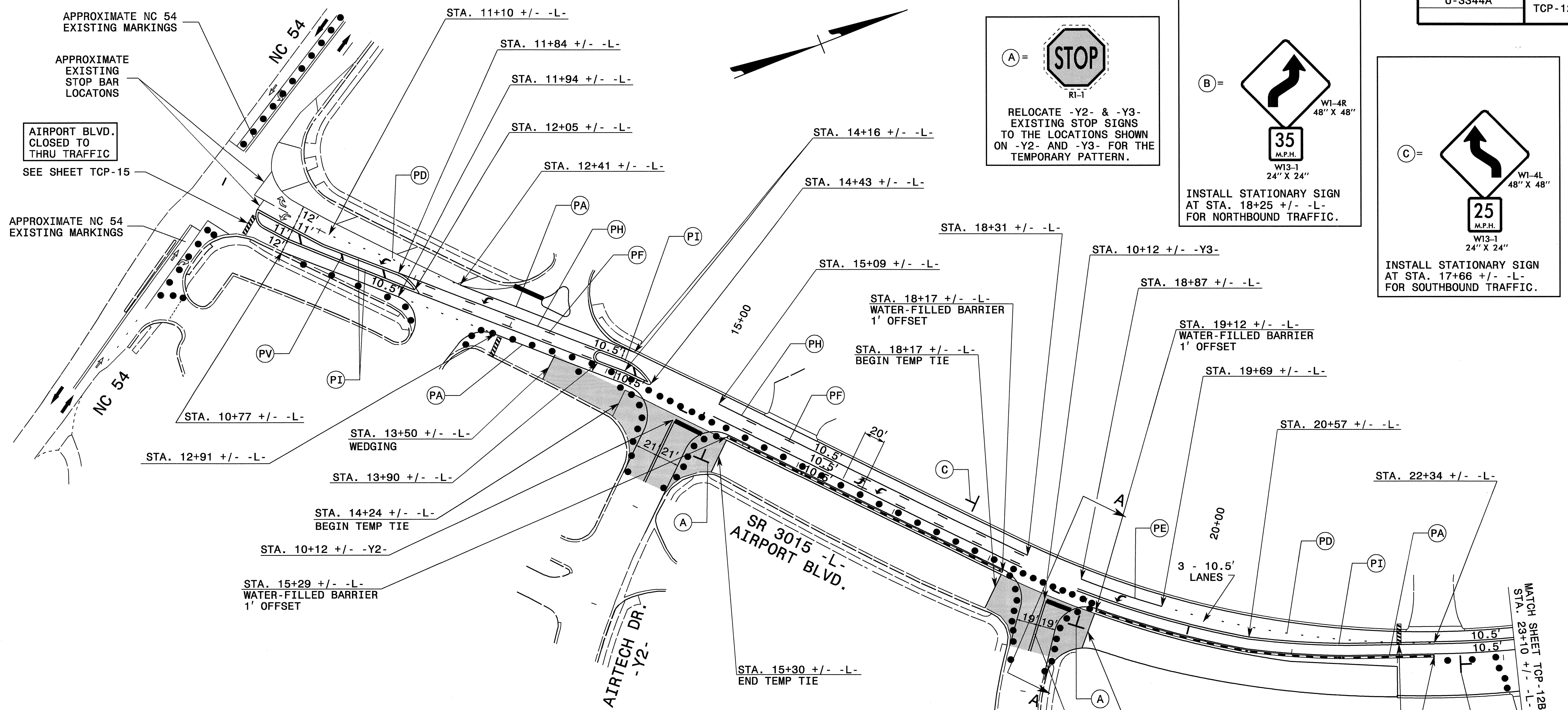

WEEKEND ROAD CLOSURE

ALL PAVEMENT MARKING SYMBOLS ARE PAINT

APPROVED: DATE: 4/5/06

SEAL

SEAL 022104

ENGINEER JOHN S. KITE, JR.

SCALE: NONE			REVISIONS	
DATE: 10-04				
DWG. BY: MHS				
DESIGN BY: MHS				
REVIEWED BY: CLM				

04-APR-2006 10:49
 \\ets-coc-fs03\U3344a\Traffic\TrafficControl\Top\U3344a_top-12a.dgn
 mvspr\inger AT WZTC222410

INSTALL STATIONARY SIGN
AT STA. 31+00 +/- -L-

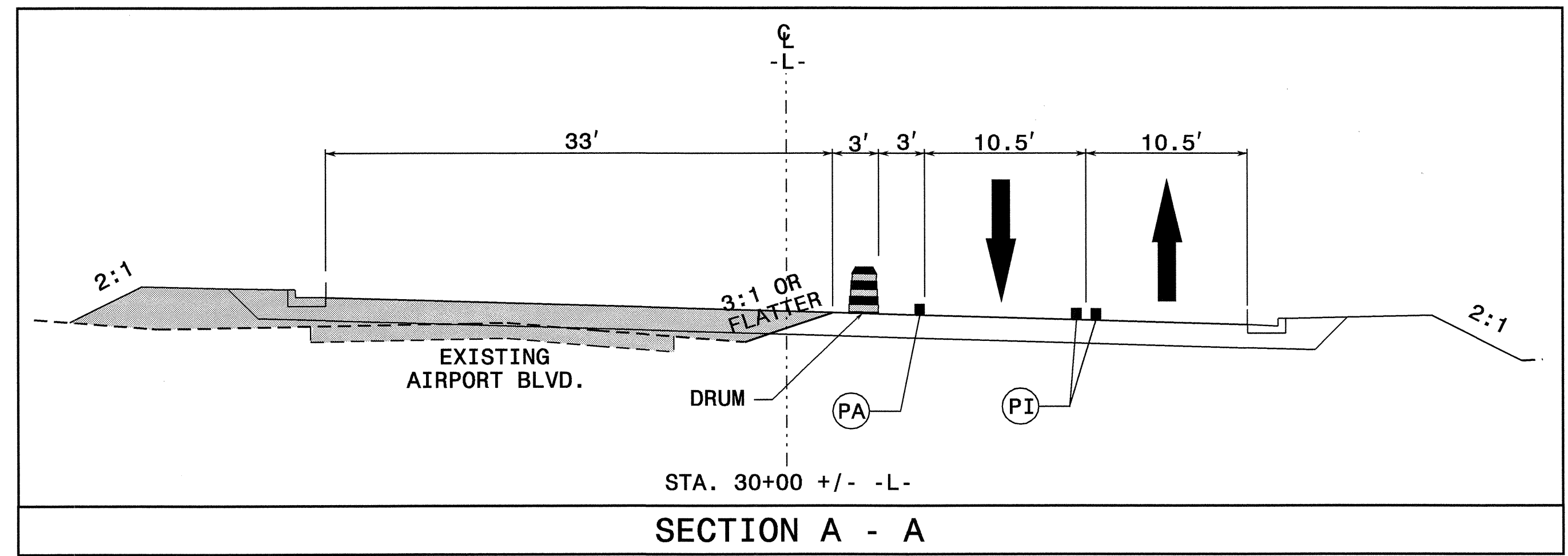
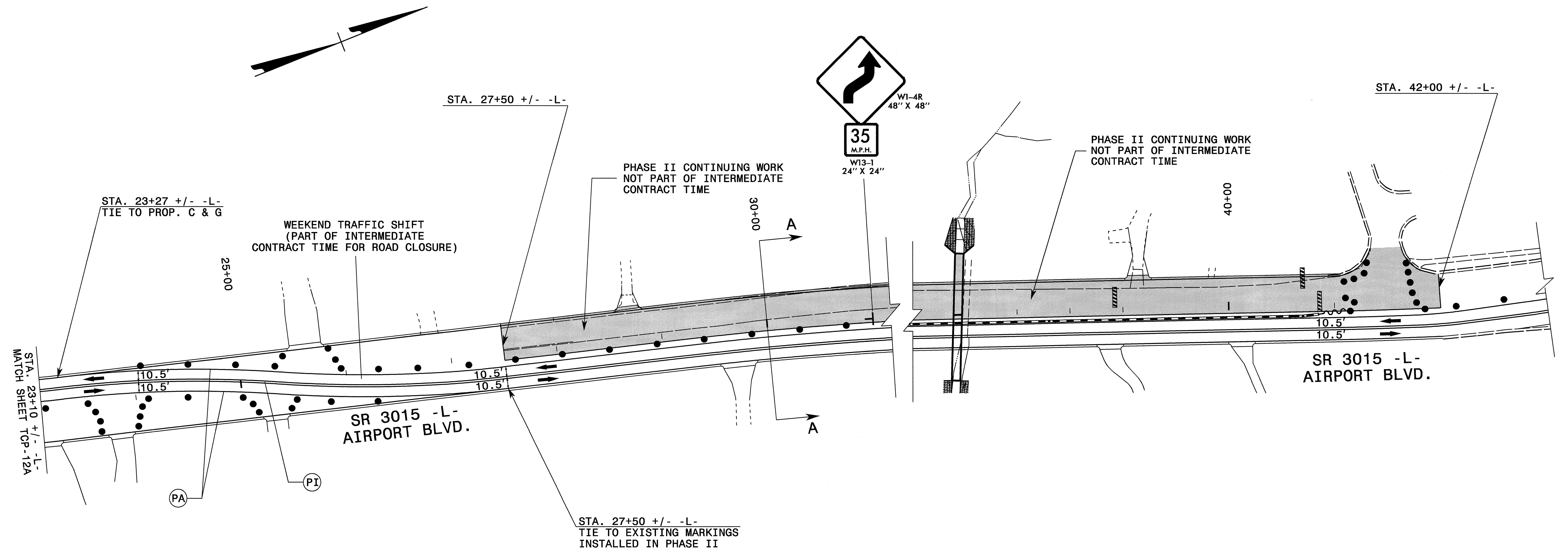

APPROVED: <i>John S. Kitt, Jr.</i> DATE: 4/15/04	PHASE III	
SCALE: NONE		REVISIONS
DATE: 10-04		
DWG. BY: MHS		
DESIGN BY: MHS		
REVIEWED BY: CLM		CADD FILE

04-APR-2006 10:50
 \\ets-ccfs03\U3344a\Traffic\TrafficControl\Top\U3344a.tc_top12b.dgn
 mvspringer AT WZTC222410

CMS'S INSTALLED IN PHASE II ALONG NC 54 (SEE TCP-9) SHALL DISPLAY THE MESSAGES SHOWN ON TCP-9 OR A MESSAGE AS DIRECTED BY THE ENGINEER. THE CMS THAT WAS RELOCATED TO SOUTH OF AVIATION PARKWAY FOR THE WEEKEND ROAD CLOSURE SHALL BE RELOCATED TO ORIGINAL LOCATION AS SHOWN ON TCP-9.

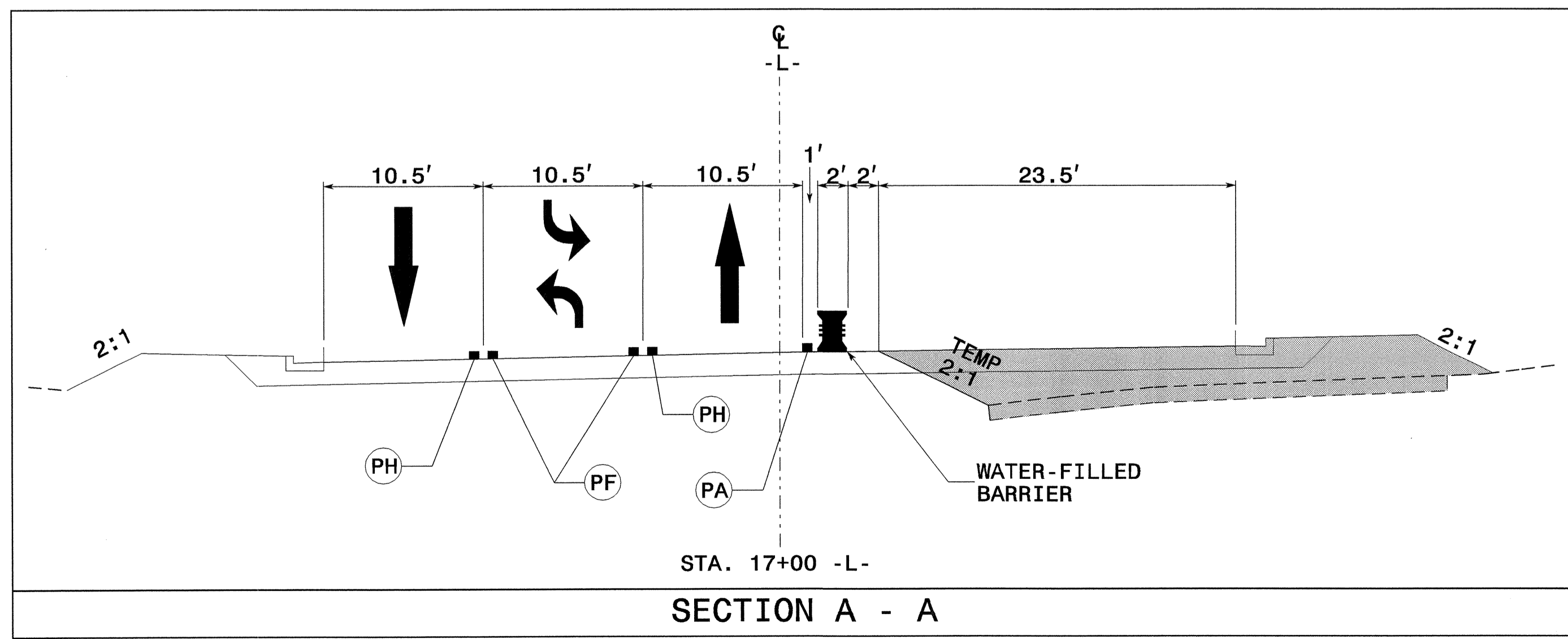
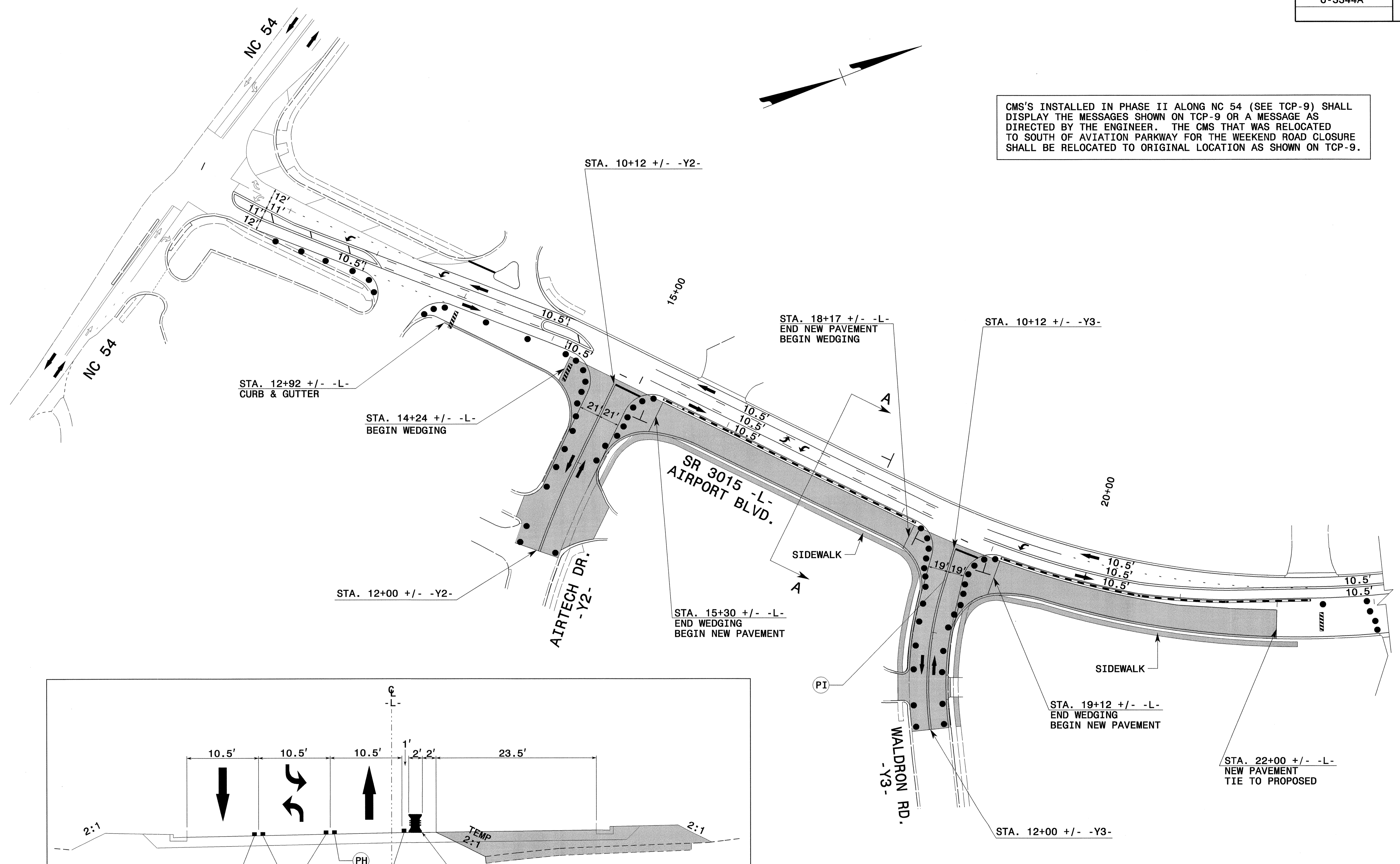

APPROVED: *[Signature]* DATE: 10/10/04
 SEAL
 SEAL 022104
 ENGINEER
 JOHN S. KITTE JR.

PHASE III			REVISIONS	
SCALE:	NONE			
DATE:	10-04			
DWG. BY:	MHS			
DESIGN BY:	MHS			
REVIEWED BY:	CLM			

19-JAN-2005 13:59
 \\efs-cf80\U3344a\TCP\U3344A.TC.TCP13.dgn
 msteelm@AT\TC212231

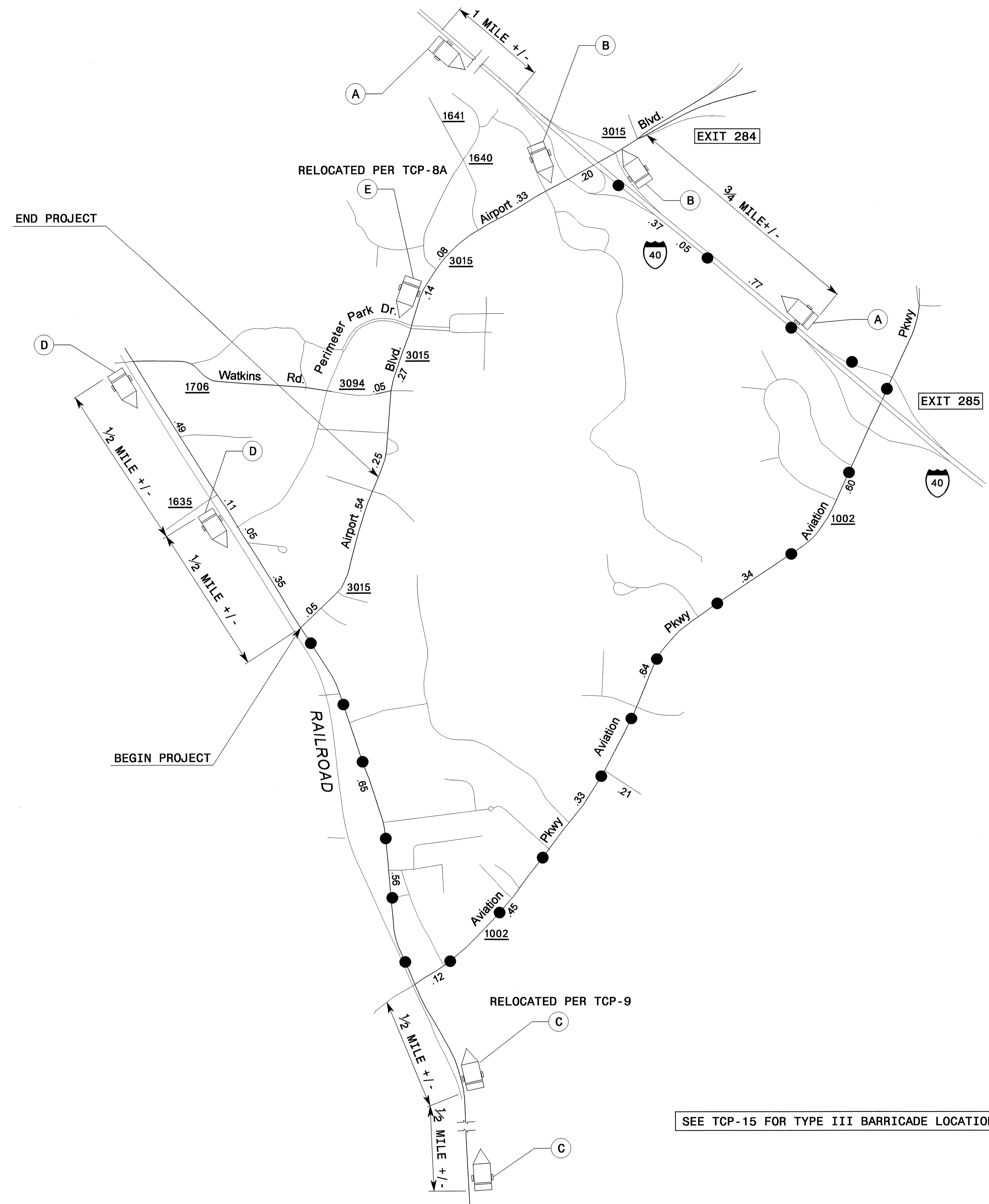

SEE TCP-15 FOR TYPE III BARRICADE LOCATIONS.

A =	SUGGESTED MESSAGES		
	MESSAGE NO. 1 AIRPORT BLVD TRAFFIC	MESSAGE NO. 2 ADVISORY INFO	MESSAGE NO. 3 AT RAMP
CHANGEABLE MESSAGE SIGN			
B =	SUGGESTED MESSAGES		
	MESSAGE NO. 1 AIRPORT BLVD CLOSED	MESSAGE NO. 2 AT NC 54	
CHANGEABLE MESSAGE SIGN			
C =	SUGGESTED MESSAGES		
	MESSAGE NO. 1 AIRPORT BLVD CLOSED	MESSAGE NO. 2 AT NC 54	MESSAGE NO. 3 USE AVIATION PARKWAY
CHANGEABLE MESSAGE SIGN			
D =	SUGGESTED MESSAGES		
	MESSAGE NO. 1 AIRPORT BLVD CLOSED	MESSAGE NO. 2 NO THRU TRAFFIC	MESSAGE NO. 3 USE AVIATION PKWY
CHANGEABLE MESSAGE SIGN			
E =	SUGGESTED MESSAGES		
	MESSAGE NO. 1 AIRPORT BLVD CLOSED	MESSAGE NO. 2 1/2 MILE AHEAD	MESSAGE NO. 3 USE LOCAL ROUTES
CHANGEABLE MESSAGE SIGN			

19-JAN-2005 14:00
 \\ets-cctso\U3344a\TCP\U3344A_TC_TCP14.dgn
 mstrleimon AT TEL212231

APPROVED: *[Signature]* DATE: 1/21/05

SEAL

DETOUR ROUTE FOR WEEKEND CLOSURE OF AIRPORT BLVD.

SCALE: NONE		REVISIONS
DATE:		
DWG. BY:		
DESIGN BY:		
REVIEWED BY:		

CADD FILE

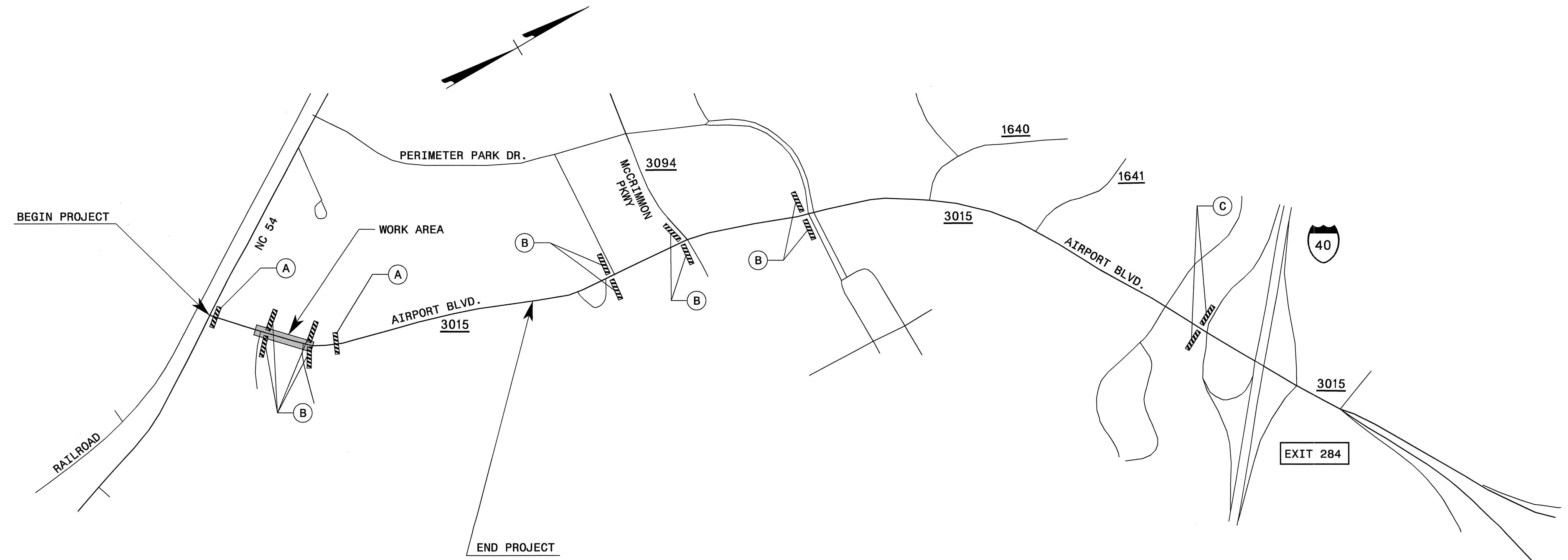
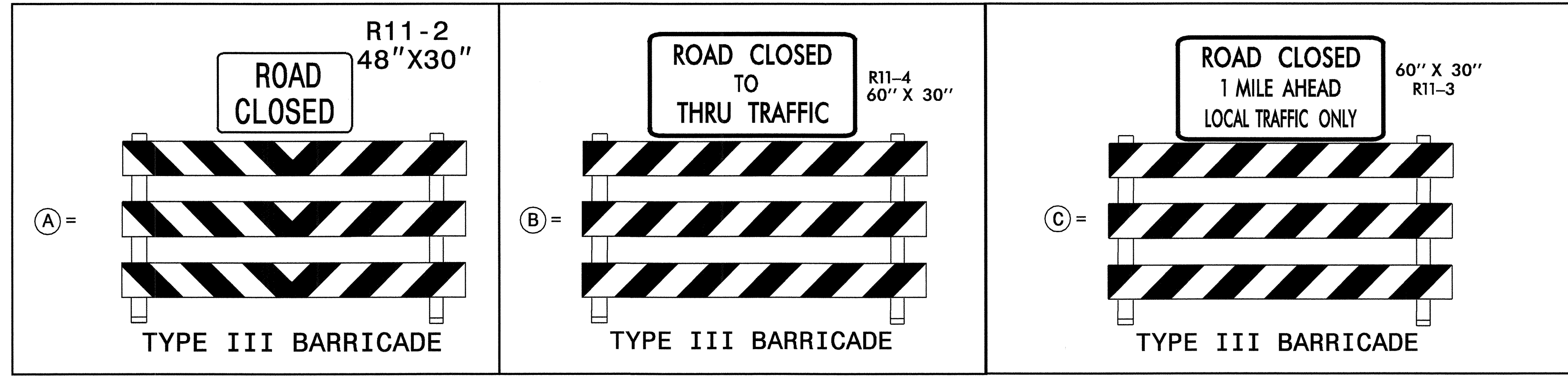

04-APR-2006 10:50
 \\lets-ccf\fs03\3344a\Traffic\TrafficControl\top\U3344A-TC-TCP15.dgn
 mvsbringer AT WZTC22240

APPROVED: <i>John S. Kite, Jr.</i> DATE: 4/5/06	BARRICADE LOCATIONS FOR WEEKEND CLOSURE OF AIRPORT BLVD.	
SCALE: NONE		REVISIONS
DATE: 12-04		
DWG. BY: MHS		
DESIGN BY: MHS		
REVIEWED BY: CLM		CADD FILE

TWO-WAY UNDIVIDED & URBAN FREEWAYS (L-LINES)

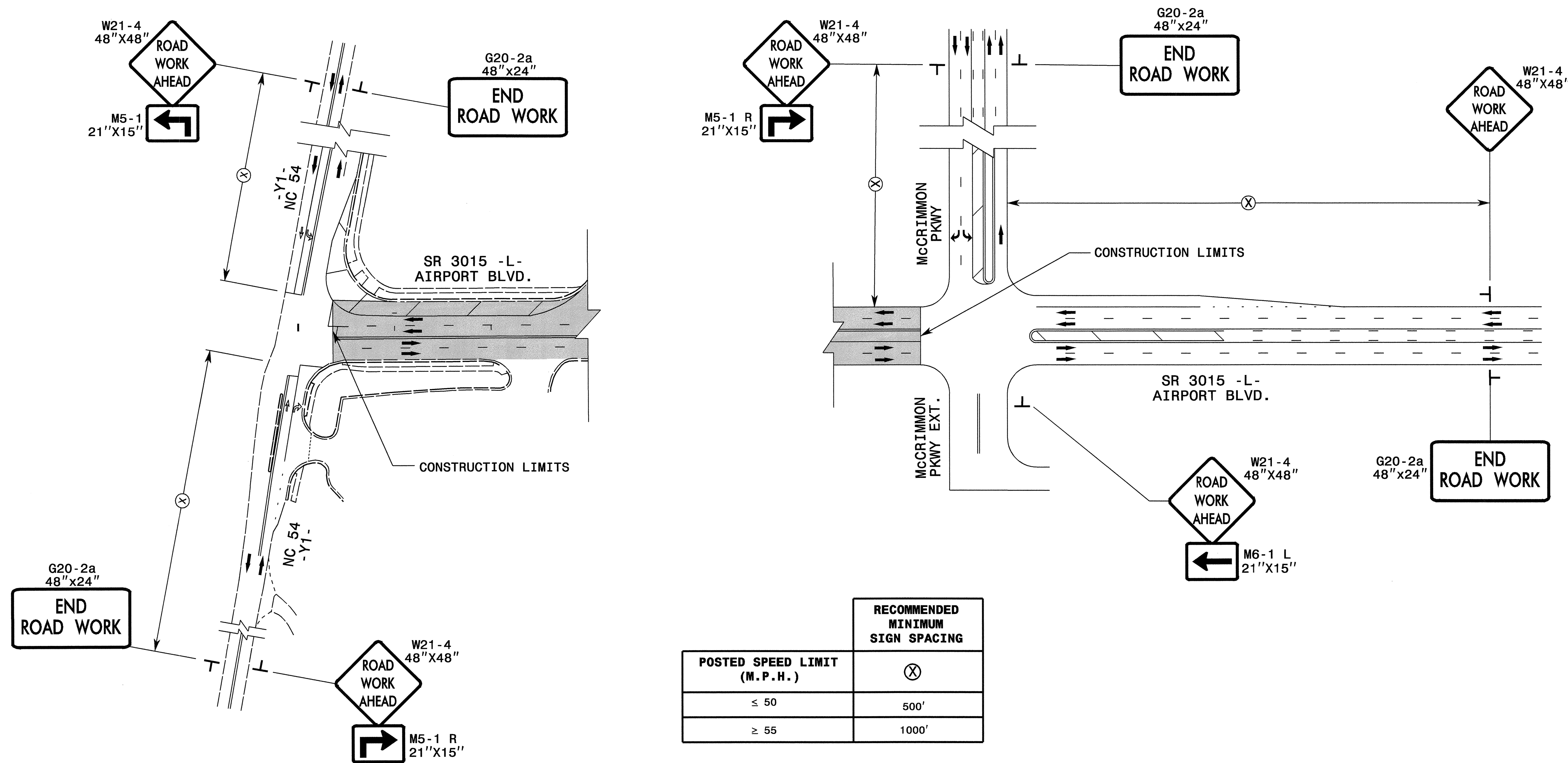

POSTED SPEED LIMIT (M.P.H.)	RECOMMENDED MINIMUM SIGN SPACING
≤ 50	⊗ 500'
≥ 55	1000'

GENERAL NOTES

- USE FLUORESCENT ORANGE SHEETING (TYPE VII OR HIGHER) ON ALL ADVANCED WORK ZONE SIGNS.
- DO NOT INSTALL ADVANCE WARNING SIGNS MORE THAN 3 DAYS PRIOR TO BEGINNING OF WORK.
- SIGNS SHOWN ARE REQUIRED FOR WORK ZONES THAT WILL REMAIN IN EFFECT OVERNIGHT. FOR SHORT-TERM DAILY MAINTENANCE TYPE OPERATIONS, THIS SIGNING APPLICATION IS OPTIONAL; MAY USE ONLY APPLICABLE ROADWAY STANDARD DRAWINGS INSTEAD. HOWEVER, IF THIS SIGNING APPLICATION IS USED, SIGNS MAY BE PORTABLE MOUNTED.
- ALL SIGN SPACING DIMENSIONS ARE APPROXIMATE, FIELD ADJUST AS NECESSARY OR AS DIRECTED.
- USE 3LB STEEL U-CHANNEL POST OR 4" X 4" WOOD POST FOR ALL WORK ZONE SIGNS. 3LB STEEL U-CHANNEL POSTS MUST MEET THE REQUIREMENTS OF STANDARD SPECIFICATION SECTION 1094-1(B), MAY BE GALVANIZED STEEL, OR MAY BE PAINTED GREEN BY THE POST MANUFACTURER. SQUARE STEEL TUBING POSTS HAVING EQUIVALENT STRENGTH OF THE 3 LB STEEL U-CHANNEL POST ARE ALSO ACCEPTABLE FOR USE. ERECT SIGNS PER ROADWAY STANDARD DRAWING 1110.01. PAYMENT FOR WOOD POSTS, 3LB STEEL U-CHANNEL AND SQUARE STEEL TUBING POSTS WITH SIGNS WILL BE MADE ACCORDING TO STANDARD SPECIFICATION "WORK ZONE SIGNS" SECTION 1110.
- WHEN NECESSARY, USE SPLICING IN ACCORDANCE WITH ROADWAY STANDARD DRAWING NO. 1110.01. REMOVE ENTIRE POST WHEN REMOVING SIGNS WITH SPLICED POSTS.
- DO NOT BACK BRACE SIGN SUPPORTS.

LEGEND

⊥ STATIONARY SIGN

➔ DIRECTION OF TRAFFIC FLOW

STATE OF NORTH CAROLINA
DEPT. OF TRANSPORTATION
DIVISION OF HIGHWAYS
RALEIGH, N.C.

**DETAIL DRAWING FOR
TWO-WAY UNDIVIDED
WORK ZONE WARNING SIGNS**

SHEET 1 OF 1

APPROVED: DATE: 4/5/04	DETAIL DRAWING FOR TWO-WAY UNDIVIDED AND URBAN FREEWAYS ADVANCED WORK ZONE WARNING SIGNS	
	SCALE: NONE	REVISIONS
	DATE: 10-04	7-98 10/01
	DWG. BY: MHS	10-98 03/04
	DESIGN BY: MHS	01/01
REVIEWED BY: CLM		<small>CAD FILE</small>

04-APR-2006 10:53
 \\efs-cfs03\033344g8\Traffic\control\top\3344a_fc_top16.dgn
 mvspfinger AT WZTC2240