

APPROXIMATE QUANTITIES ONLY. UNCLASSIFIED EXCAVATION, SHOULDER  
 BORROW, FINE GRADING, CLEARING AND GROBBING, AND BREAKING OF EXISTING  
 PAVEMENT, WILL BE PAID FOR AT THE CONTRACT LUMP SUM PRICE FOR "GRADING".

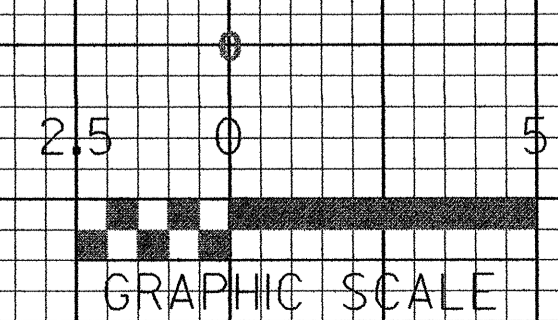

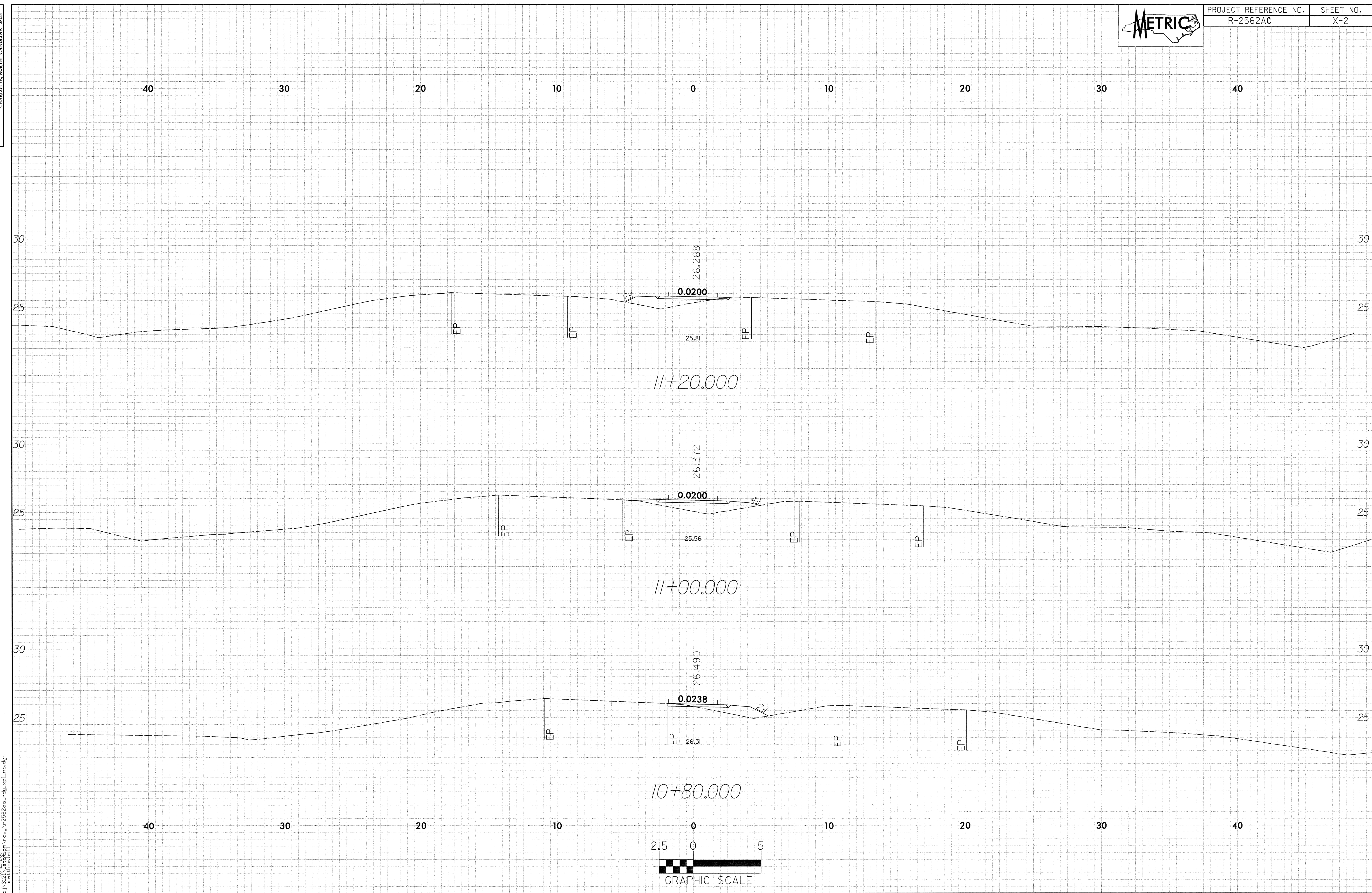

r:\proj\1012\1012\1012.dwg 12/20/04  
 r:\proj\1012\1012\1012.dwg 12/20/04  
 r:\proj\1012\1012\1012.dwg 12/20/04

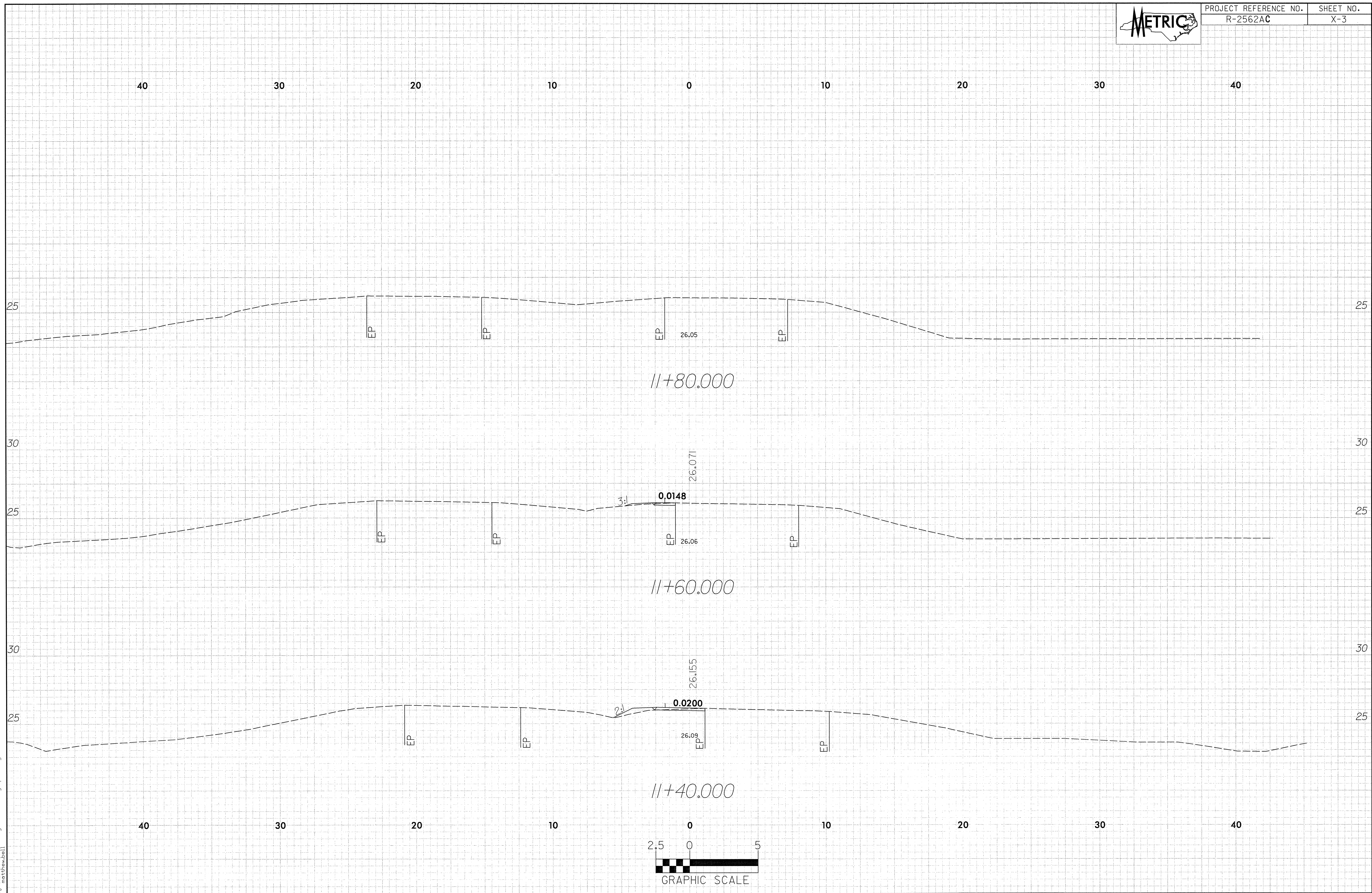

m:\proj\2562\12/2004\1\rdg\2562aa\_rdy\_wpl\_nb.dgn  
 mattheus

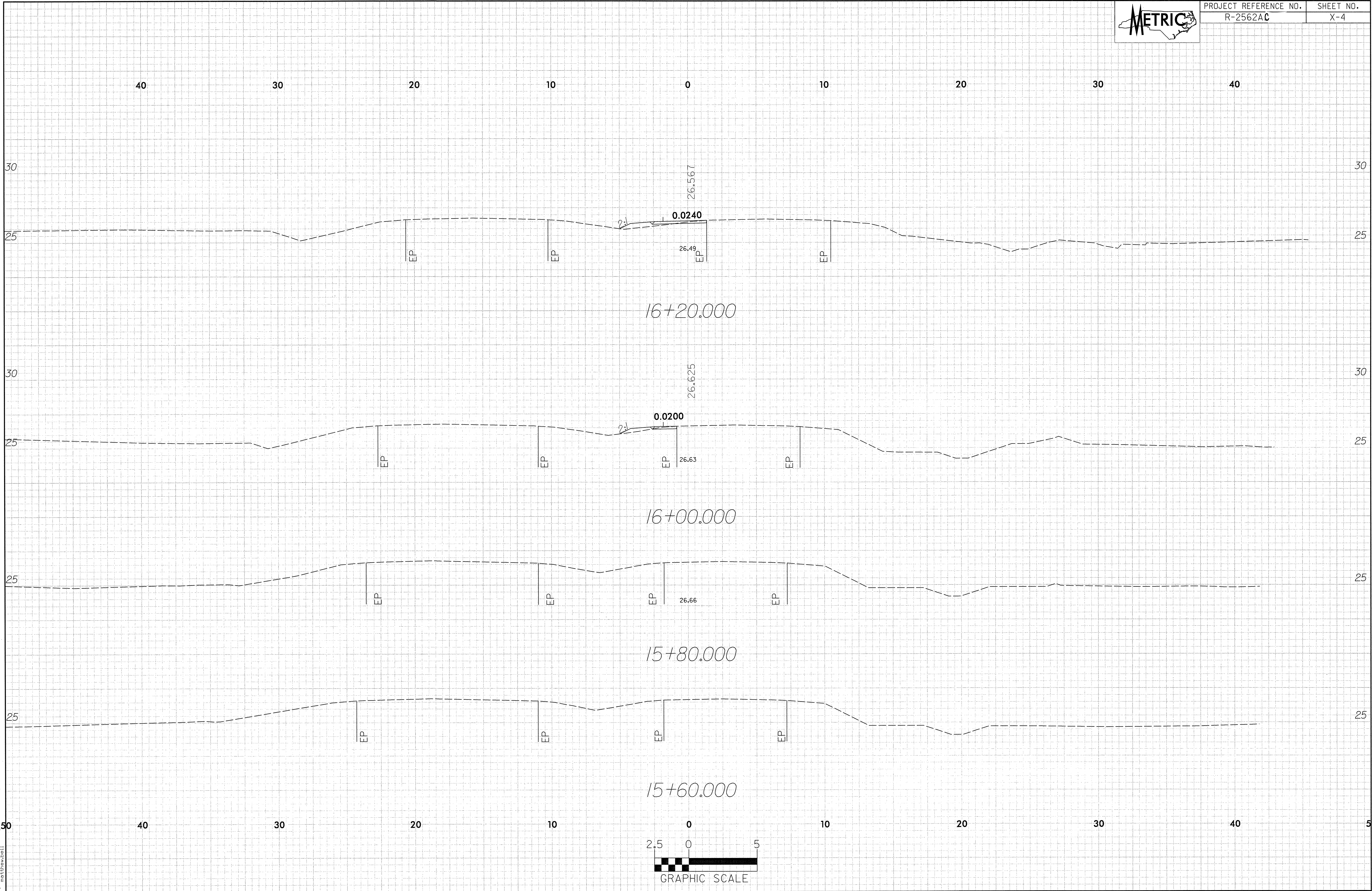

nt:\proj\3128\12/2004\1\rdm\2562ac\_rdy\_xpl\_nb.dgn  
mattiewebel

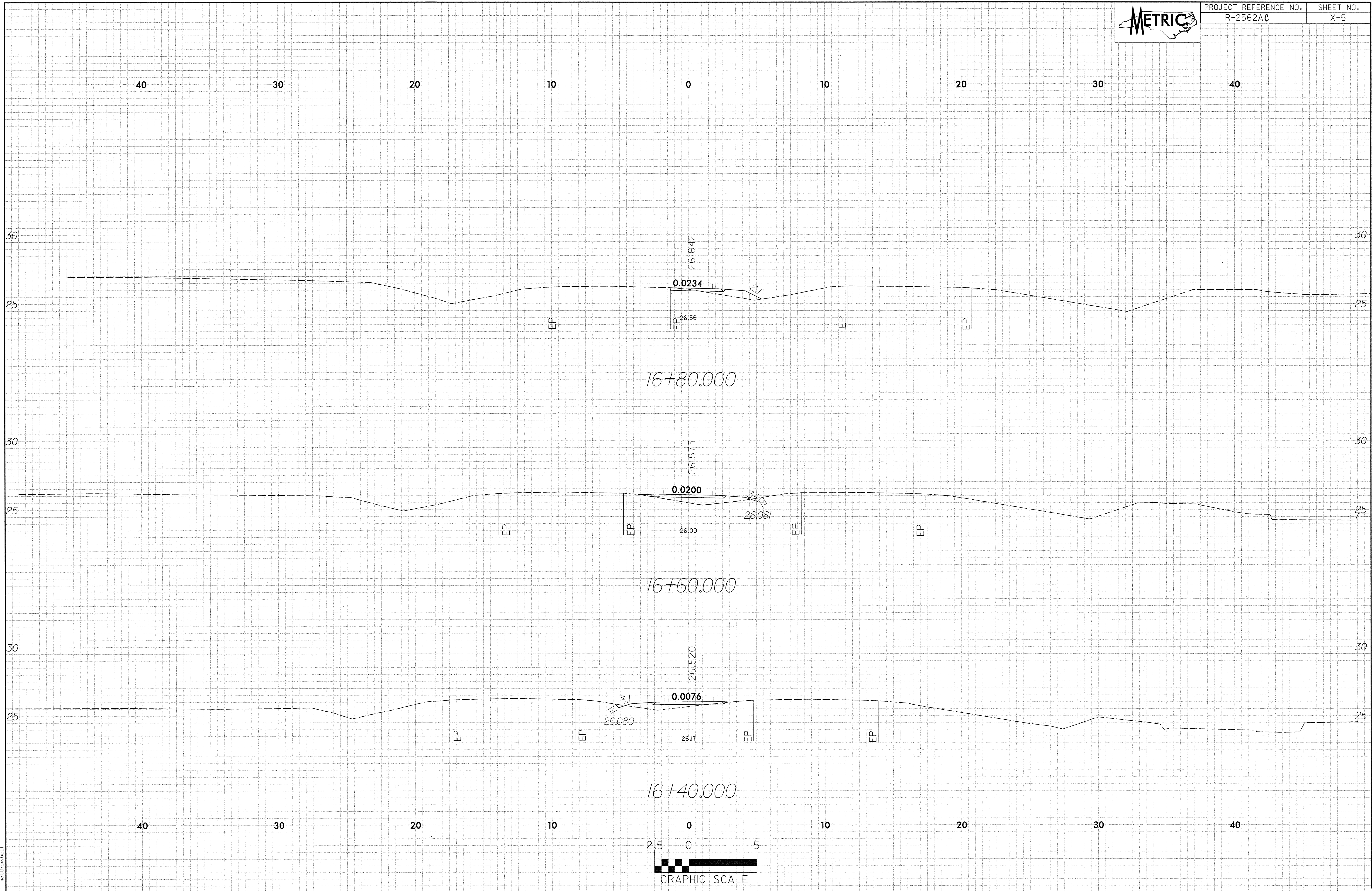

n:\p\c\312\122004\1\dwg\2562ac\_rdy\_wpl.ncb.dgn  
 mattheba11

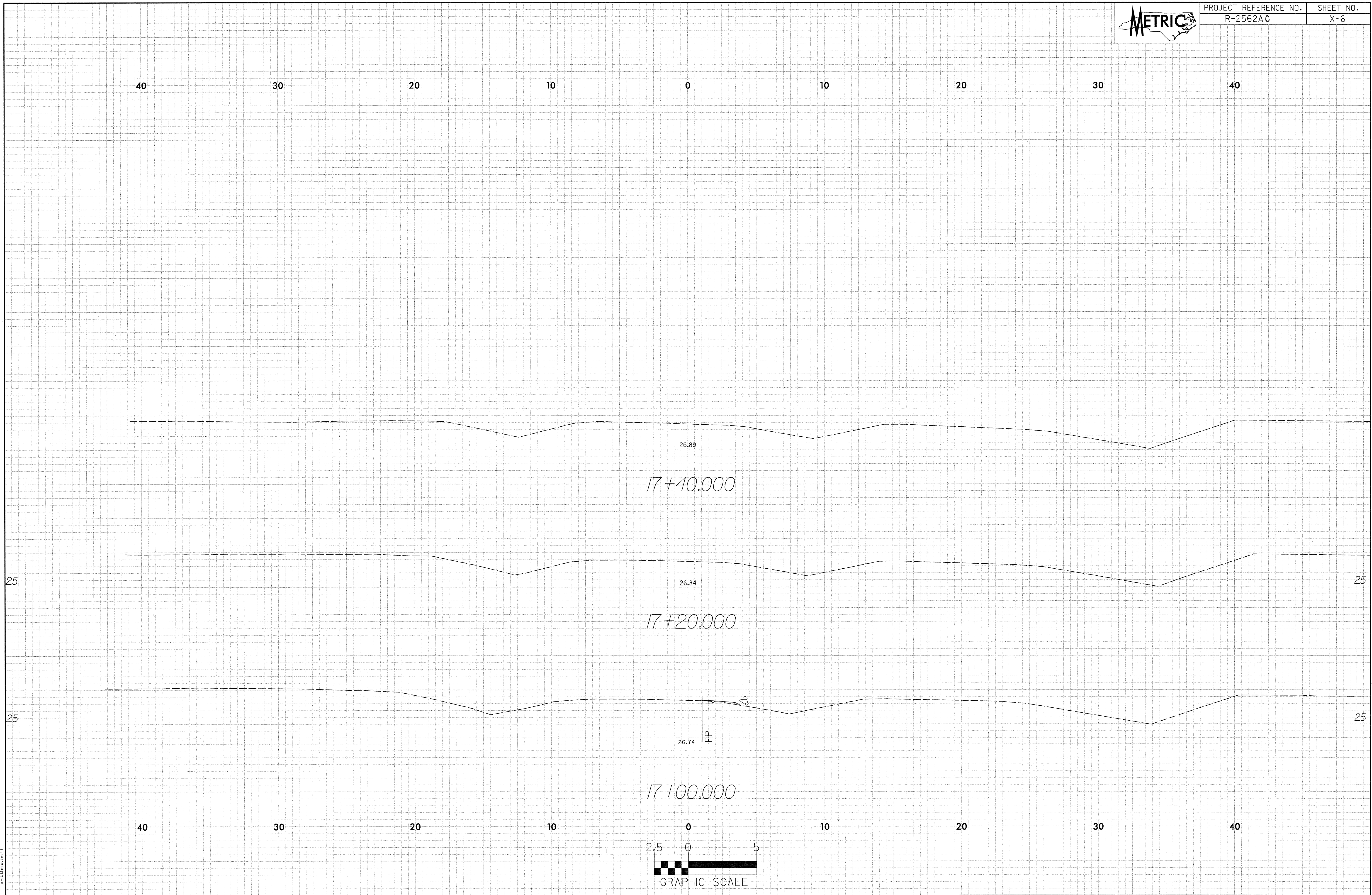

m:\pco\312\152004\rdwg\2562a-c\_rdy\_rpl\_nb.dgn  
 11/15/2004 10:28:58 AM

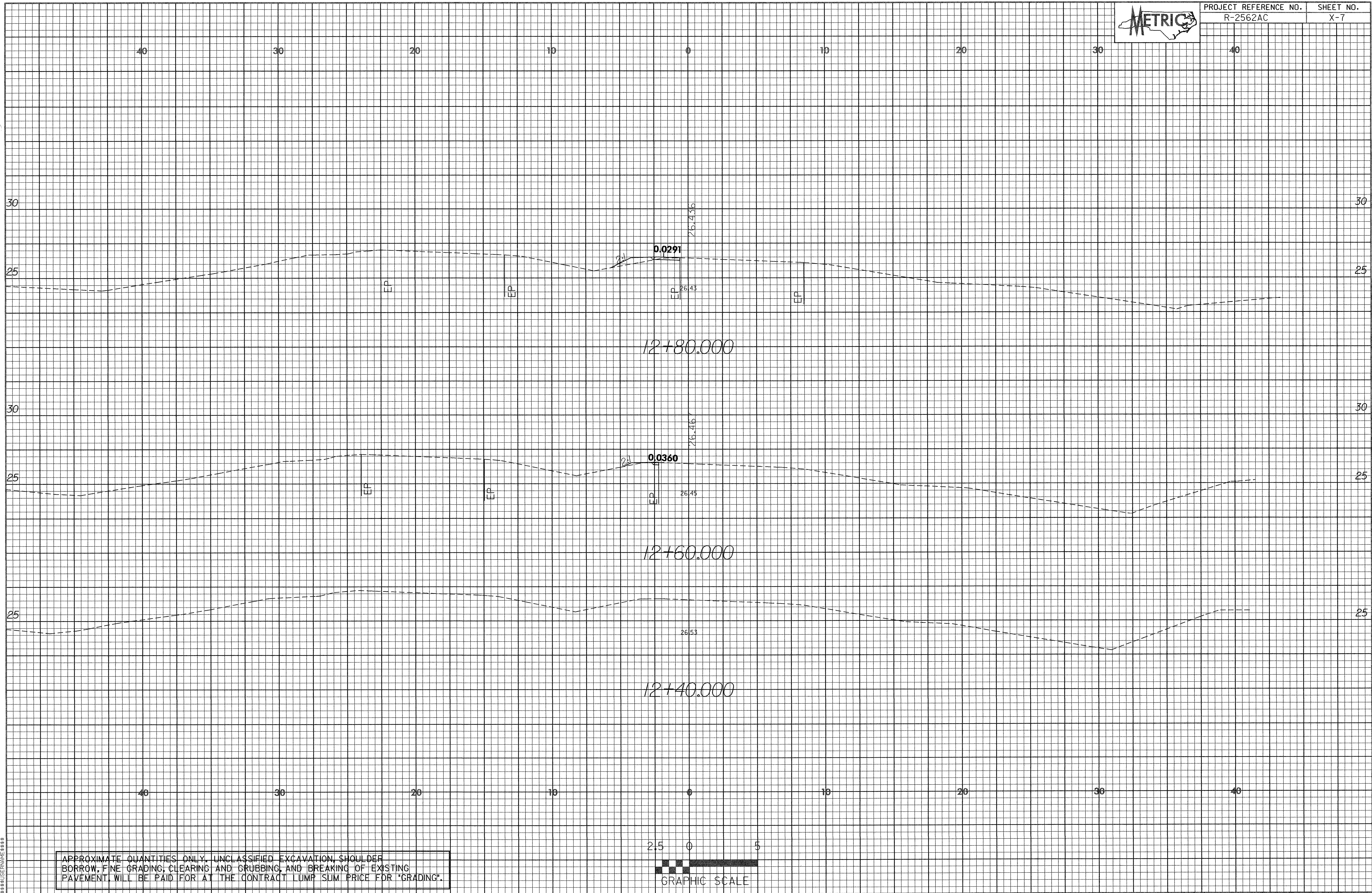

APPROXIMATE QUANTITIES ONLY. UNCLASSIFIED EXCAVATION, SHOULDER BORROW, FINE GRADING, CLEARING AND GRUBBING, AND BREAKING OF EXISTING PAVEMENT WILL BE PAID FOR AT THE CONTRACT LUMP SUM PRICE FOR "GRADING".

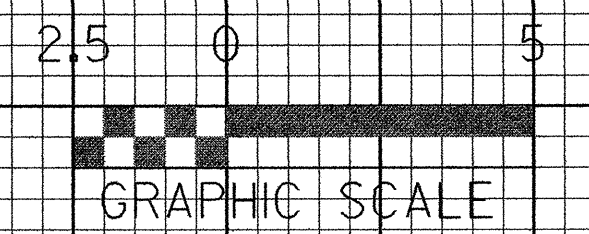

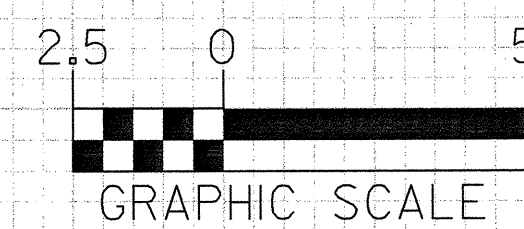
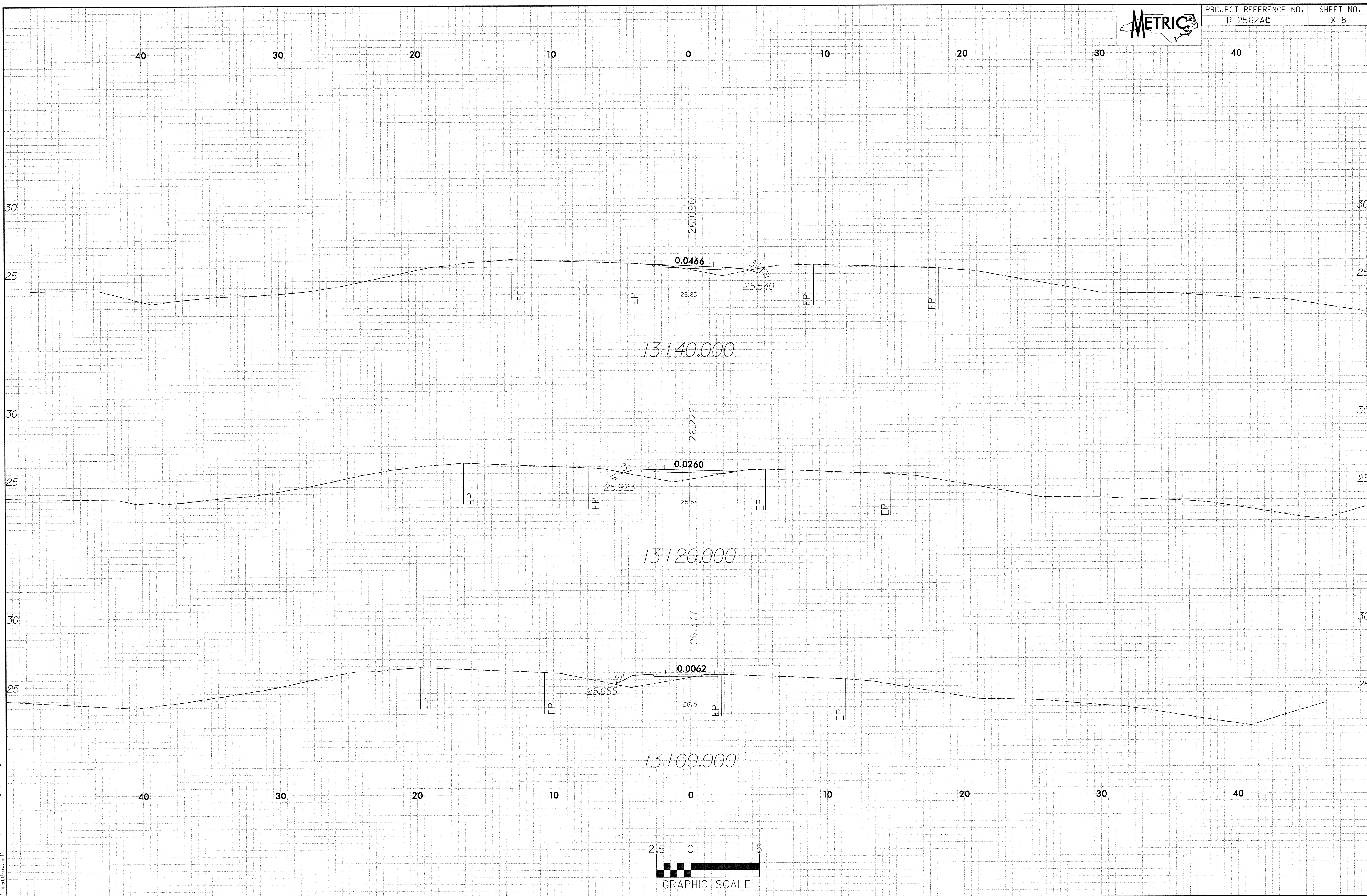

m:\proj\13\13+00\13+00.dwg\2562ac\_r.dwg\13+00.dgn  
 12/2/2004  
 10:15:00 AM  
 13+00.dwg





40 30 20 10 0 10 20 30 40

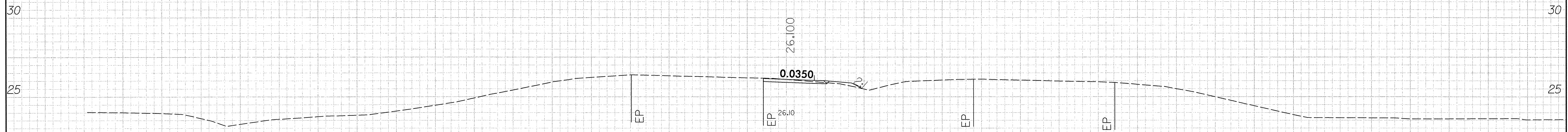
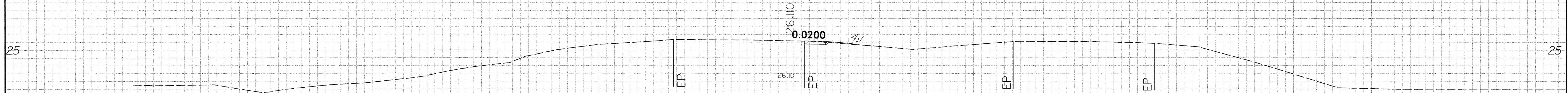

40 30 20 10 0 10 20 30 40

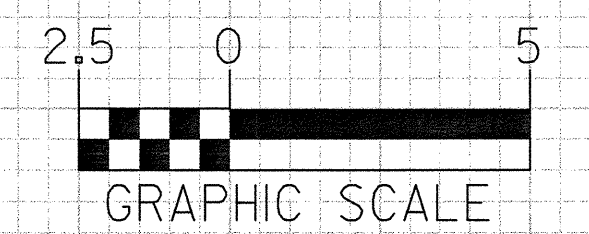

m:\pro\1\2\12/2004\2562ac\13+60\13+60.dgn

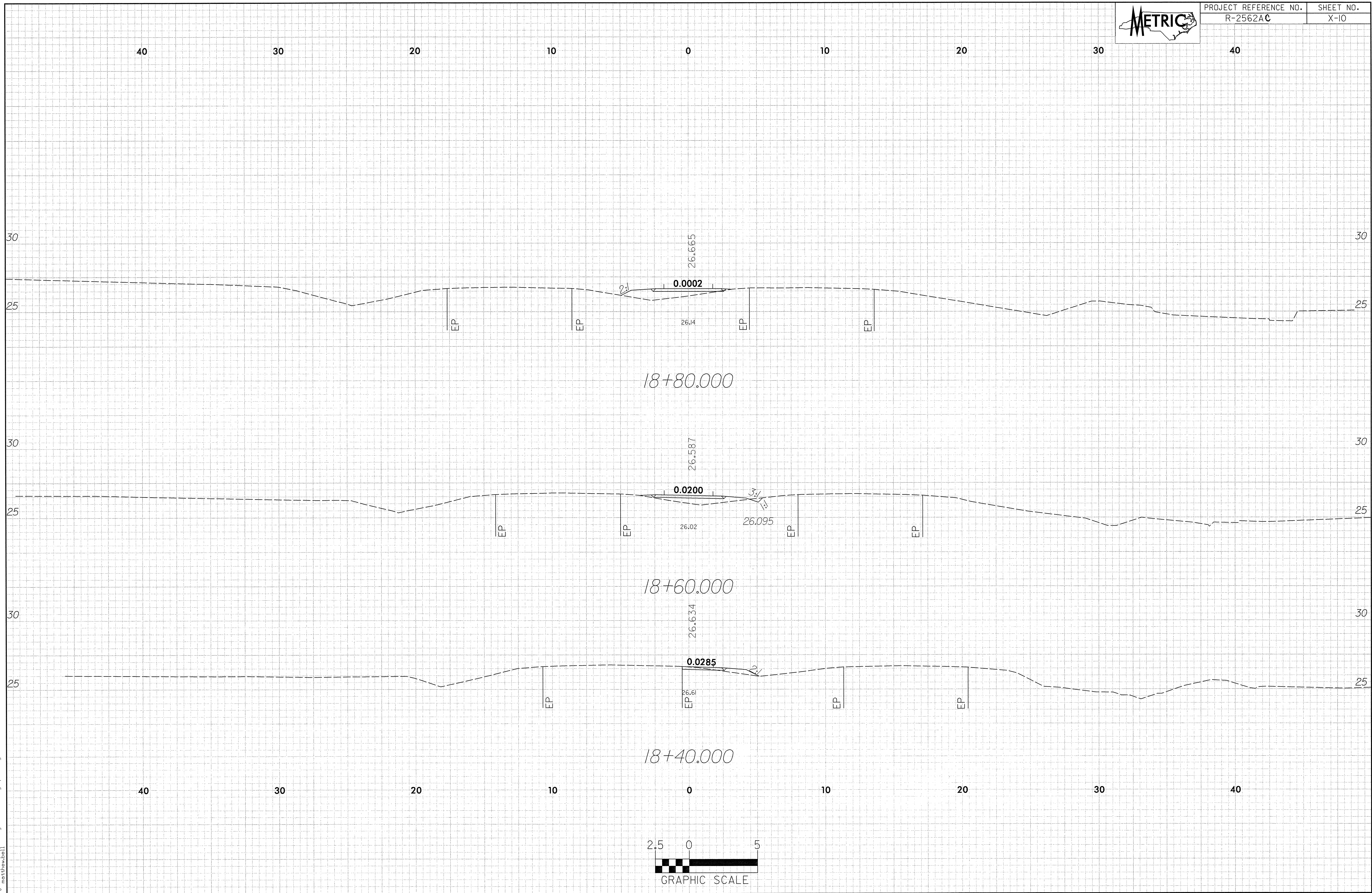

n:\proj\315\12/2004\vdh\2562ac\_rdy\_xpl\_sb.dgn  
 matthew.dal

40 30 20 10 0 10 20 30 40

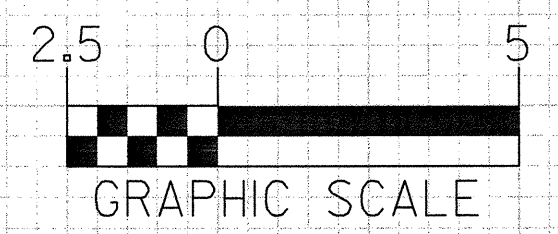
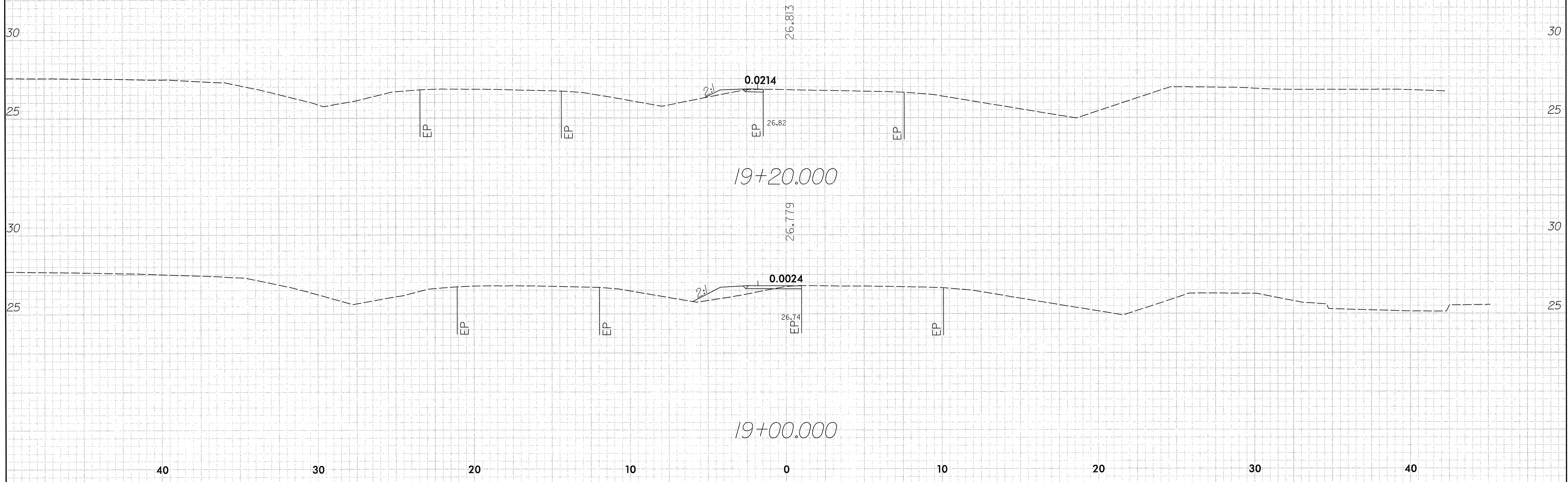

n:\proj\13128\122004\matthew\_b\1\rdw\2562ac\_rdy\_xpl.sbdgn  
 12/2/2004  
 matthew\_b