

**TIP PROJECT: B-3349**

01-APR-2004 15:39  
M:\Peoples-Unit\Workgroups\TIP Projects\B-3349\Signals\B3349\_Sig\_1.Tsh.dgn

9/09/99

Project No.	Sheet No.
B-3349	Sig. 1

STATE OF NORTH CAROLINA  
DIVISION OF HIGHWAYS

**HYDE COUNTY**

**LOCATION: BRIDGE NO. 32 OVER ROSE BAY CREEK ON US 264**  
**TYPE OF WORK: TEMPORARY SIGNALS**

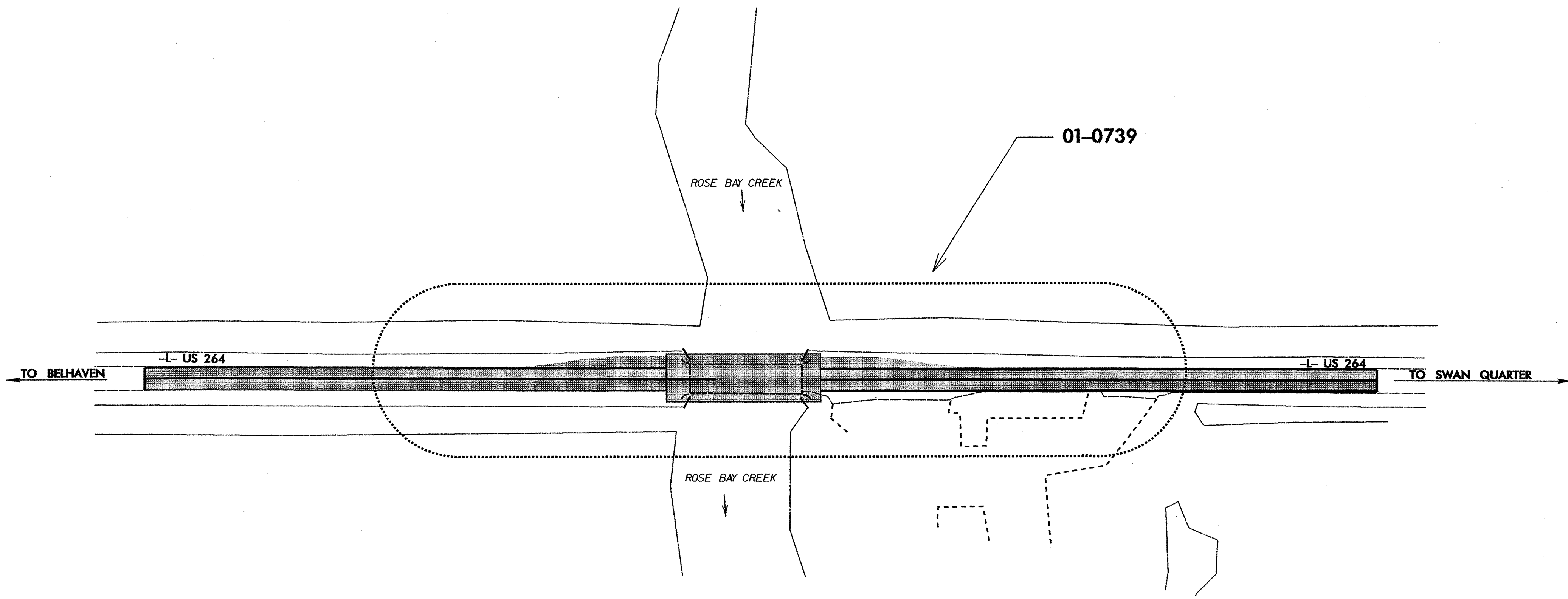
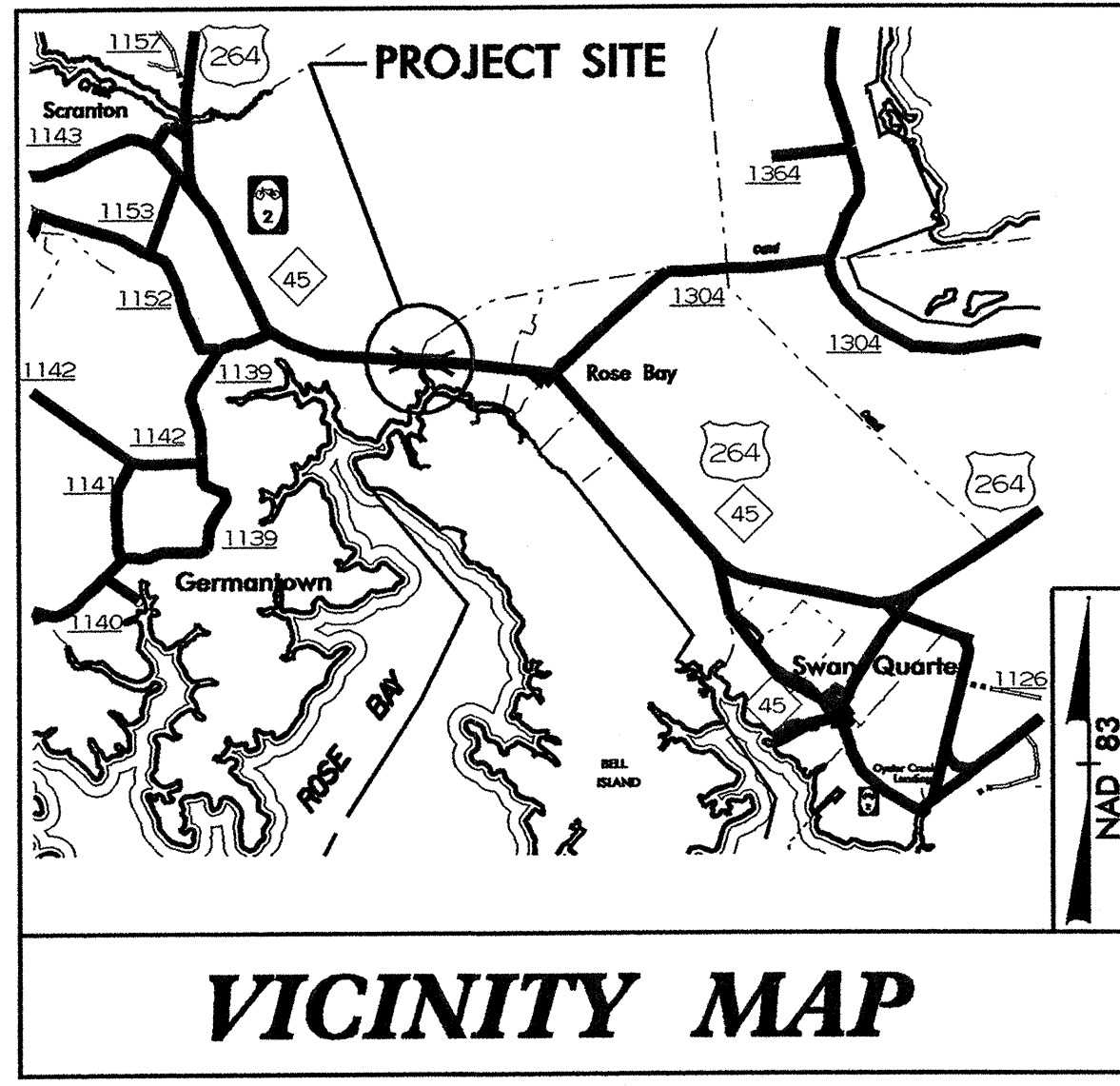

Refer to "Roadway Standard Drawings NCDOT" dated January 2002 and "Standard Specifications for Roads and Structures" dated January 2002.

Sheet #	Reference #	Index of Plans	Location/Description
Sig. 1		Title Sheet	
Sig. 2-5	01-0739	US 64 At Bridge No. 32 Over Rose Bay Creek	
Sig. 6	N/A	2070L Cabinet Typical	

**TRAFFIC MANAGEMENT AND SIGNAL SYSTEMS UNIT**  
Contacts:  
**D. Y. Ishak - Signals and Geometrics Contracts Engineer**  
**G. C. Brown, PE - Signal Equipment Design Engineer**  
**G. G. Murr, Jr., PE - Traffic Management Systems Engineer**

Prepared In the Office of:  
DIVISION OF HIGHWAYS  
**TRAFFIC ENGINEERING AND SAFETY SYSTEMS BRANCH**

122 N. McDowell St., Raleigh, NC 27603